

---

**RCSL No:** 44-RT1953

**Edition:** July 1980

**Author:** Karsten Friis

---

**Title:**

GENERAL INFORMATION

RC3803S

REVISION 0

---

---

**Keywords:**

RC3803S, GENERAL INFORMATION, Revision 0.

---

**Abstract:**

This paper contains general information of the central processor unit, RC3803S.

(20 printed pages)

---

Copyright © 1980, A/S Regnecentralen af 1979  
RC Computer A/S

Printed by A/S Regnecentralen af 1979, Copenhagen

Users of this manual are cautioned that the specifications contained herein are subject to change by RC at any time without prior notice. RC is not responsible for typographical or arithmetic errors which may appear in this manual and shall not be responsible for any damages caused by reliance on any of the materials presented.

<u>CONTENTS.</u>	<u>PAGE.</u>
1.           GENEREL DESCRIPTION.....	1
2.           SPECIFICATIONS.....	1
2.1       Performance Specifications.....	1
2.2       Electrical Specifications.....	2
2.3       Environmental Specifications.....	3
2.4       Physical Specifications.....	3
3.           IDENTIFICATION OF ITEMS.....	3
4.           INSTALLATION.....	4
4.1       Installation of CPU720 and MEM720 in CHS718 Chassis.....	4
4.2       Internal Physical Organisation.....	6
4.3       Jack/Plugs.....	6
4.4       Interconnection of Units.....	8
4.5       Installation of Program Load PROM's.....	10
5.           CHECK-OUT PROCEDURE.....	10

This page is intentionally left blank.

1. GENERAL DESCRIPTION.

1.

The RC3803 Central Unit consists of a CPU720 Central Processing Unit and a MEM720 Semiconductor Memory and I/O controller, housed in a CHS718 chassis. The CHS718 includes DC power and free slots for 3 additional controller boards.

2. SPECIFICATIONS.

2.

2.1 Performance Specifications.

2.1

Word Length:	16 bits.
Hardware Accumulators:	4.
Index Registers:	2 hardware.
Address Modes:	Direct addressing of 1024 words, absolute, relative, and indexed modes; index addressing of up to 64K words;
Memory Cycle Time:	500 us.
Memory Access Time:	350 us
Memory Capacity:	128 K bytes
Memory type:	Dynamic Semiconductor Memory.
Max. DMA Transfer Rate:	1.25M words per second.
Input/Output System:	16-bit word length, 16 priority interrupt levels, 62 devices addressable.

I/O BUS Levels:	Ground and + 3 volts.
Standard Features:	Power Monitor Real Time Clock 2 Teletype Controllers. Paper Tape Reader Controller Paper Tape Punch Controller 3 Free slots for additional Controllers. Parity check on memory. Automatic Program Load from: 9-track magnetic tape, 8-channel paper tape, 80-column punched cards, Flexible Disc Drive, or Disc Drive
Optional Features:	F09 additional controller chassis containing separate power supply and five slots for controller boards and an I/O bus cable connecting it to the processing unit. Diagnostic Panel TCP701.

## 2.2 Electrical Specifications.

2.2

DC Power Consumption:	
CPU720:	+ 5V $\pm$ 5% 13A
MEM720:	+ 5V $\pm$ 5% 4A
	+12V $\pm$ 5% 5A
	-12V $\pm$ 5% 0.2A
	-12V 8A
DC Power for additional controllers in CHS718:	+12V 3A
	+ 5V 3A
	2x100W of optional DC power
AC Power Consumption:	220V, 5 cps., 4A max.
Heat Dissipation:	700W max., 435 Kcal/h, 3000 BTU/h.

2.3 Environmental Specifications.

2.3

Ambient Temperature: 10-40°C (50-104°F).  
 Relative Humidity: 20-80% (no condensation).

2.4 Physical Specifications.

2.4

Dimensions:  
 Height: 31.1 cm (12 1/4 inches)  
 Width: For cabinet mounting  
 Depth: For cabinet mounting

Weight: 35 kg (77 lbs.)

Mounting: Low Cabinet (F90)  
 Desk Top Cabinet (F91)  
 Midi Cabinet (F92)  
 High Cabinet (F93)

3. IDENTIFICATION OF ITEMS.

3.

<u>Item.</u>	<u>Reference No.</u>	<u>Description.</u>
1	CPU720	Central Processor
2	CHS718	CPU Chassis
3	MEM720	128K bytes memory and I/O controllers
4	PDP711	Power Panel
5	CBL491	Internal Chassis Cable
6	CBL920	Internal Chassis Cable
7	CBL061	Memory Bus
8	CBL065	Power Cable
9	CBL879	Power Cable
10	SSB301	Logo
11	AFH057	Accessories for Chassis
12	ROM789	Autoload A
13	ROM790	Autoload B
14	ROM791	Autoload C

<u>Item</u>	<u>Reference No.</u>	<u>Description</u>
15	DDM139	RC3803S Documentation
16	DAT511	Seperate Documentation Items for RC3803S

#### 4. INSTALLATION.

4.

This section describes where the different circuit boards physically are located and how the RC3803S is connected to the Operators Control Panel, additional controller chassis, peripheral units and main supply. The installation of the autoload ROM's is described as well.

#### 4.1 Installation of CPU720 and MEM720 in CHS718 Chassis.

4.1

The CPU720 and MEM720 must be mounted in the two topmost positions in the chassis. In the following, the installation of the internal cables CBL491 and CBL920 as well as the memory motherboard CBL061 is described.

- a. Remove the RC2236 PCB from the two upper positions.
- b. Remove the bottom of the CHS718 by loosening the two screws on the front and pull it free of the slides.

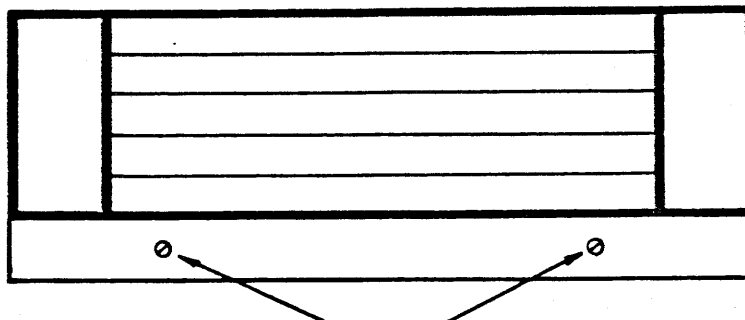

Fig. 4.1.1 Front view of CHS718.



c. Mount the CBL491 internal controller cable in the following order:

1. Mount the bracket with the 19-pin connector at the back of the chassis (A) and connect the chassis terminal.
2. Lead the free end of the CBL491 through the hole (B) in the chassis.

d. Mount the CBL920 in a similar manner.

e. Slide in the bottom of the chassis and tighten screws.

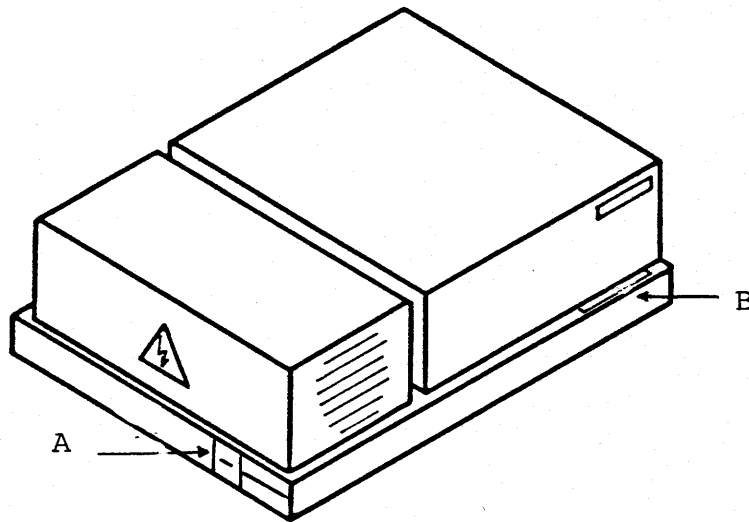
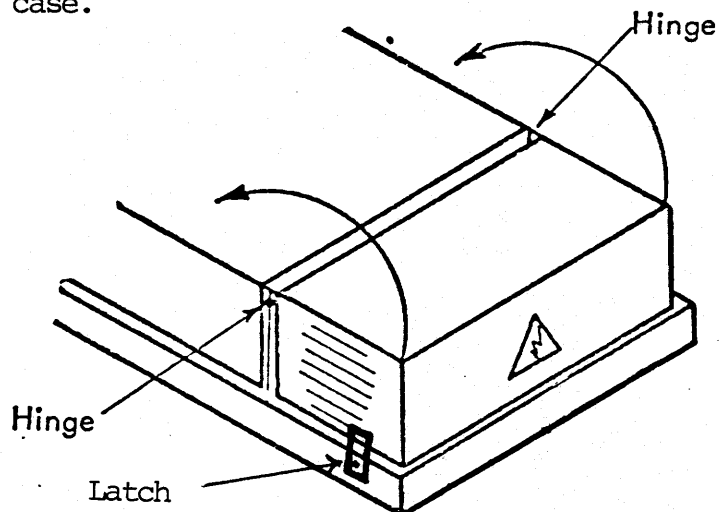

Fig. 4.1.2. Rear and side view of CHS718.

f. Loosen the latches on both sides of the power supply, and turn the power supply over the hinges to lay upon the controller board case.



- g. Mount the CBL061 two slot motherboard in the topmost position 1002.
- h. Mount the power supply.
- i. Install the autoloader ROM's on the CPU (section 4.5) and set the DIP switches on the MEM720 (Refer to 44RT1954 "Technical Manual for MEM720", section 2). Then slide in the two boards and mount the edge connectors of CBL491 and CBL920 on the 1004 connector on the CPU720 and the MEM720 respectively.

#### 4.2 Internal Physical Organisation.

4.2

Fig. 4.1.1 illustrates the mechanical configuration of the RC3803 cassette.

The CPU720 is placed in the upper position, and MEM720 is placed just below. The last three slots can be used for various controller boards.

In the power supply two free slots may be used for additional power modules of 100W each.

#### 4.3 Jack/Plugs.

4.3

Seven connectors are located at the back of the CPU cassette. (Refer to fig. 4.3.1):

SIDE VIEW

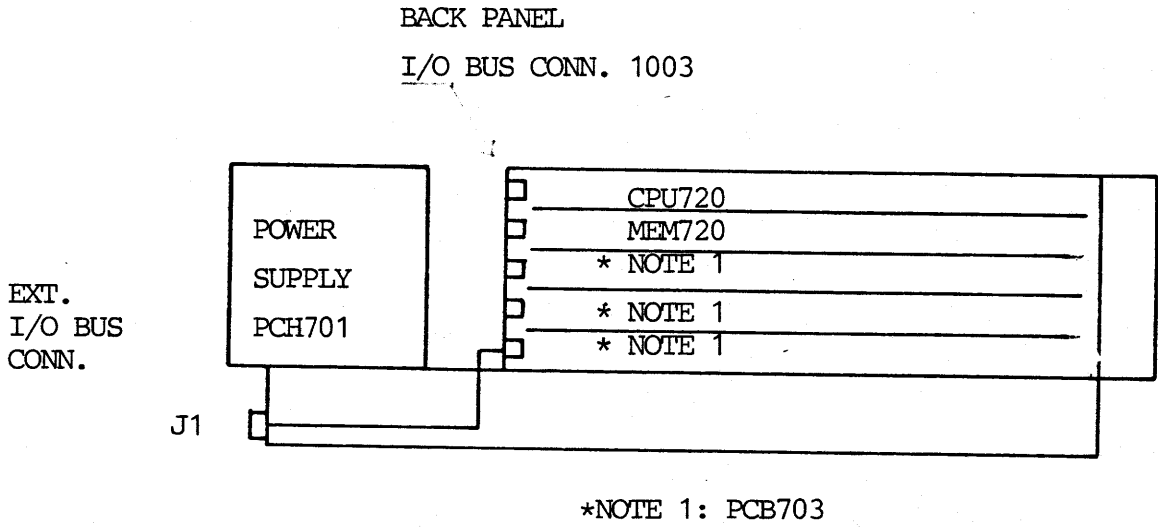

REAR VIEW

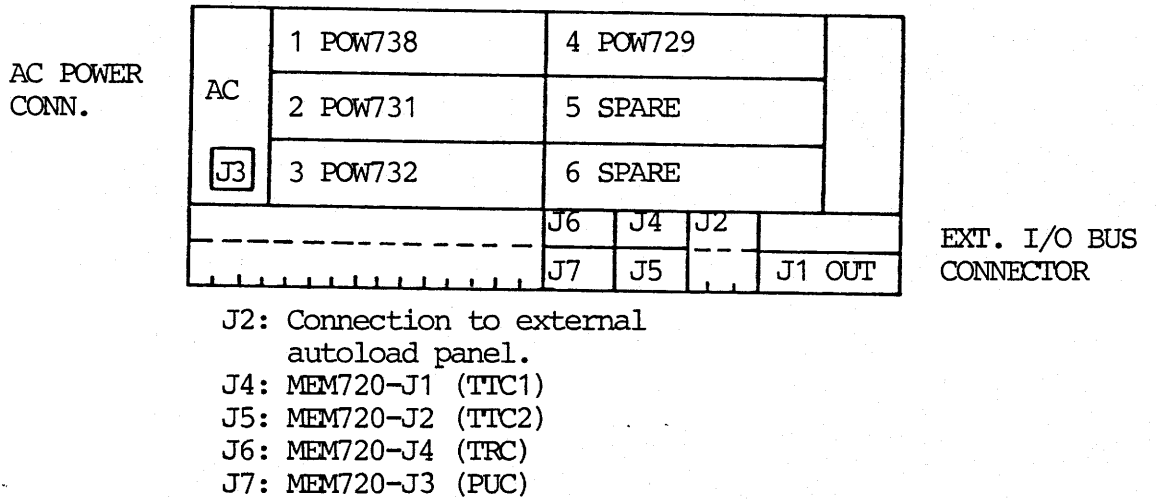

Fig. 4.3.1 MECHANICAL OUTLINE

- J1: External I/O-Bus connector, 100-pins Cannon connector.
- J2: Plug for Operators Control Panel, 2x2DE 19-pins  
Cannon Connector.
- J3: 220V AC power Connector.
- J4: Connector for first teletype (Consol), 9-pins Cannon  
Connector.
- J5: Connector for second teletype.
- J6: Connector for Paper tape Reader, 2x2DE 19-pins  
Cannon Connector.
- J7: Connector for Paper Tape Punch, 2x2De 19-pins Cannon  
Connector.

For further information on the individual jacks/plugs, refer to the Technical manuals for the CPU720 and MEM720.

#### 4.4 Interconnection of Units.

4.4

In fig. 4.4.1, a schematic diagram illustrates the interconnection between the different units.

Note that not all units need to be present, and that some units and cables may be replaced by similar variants.

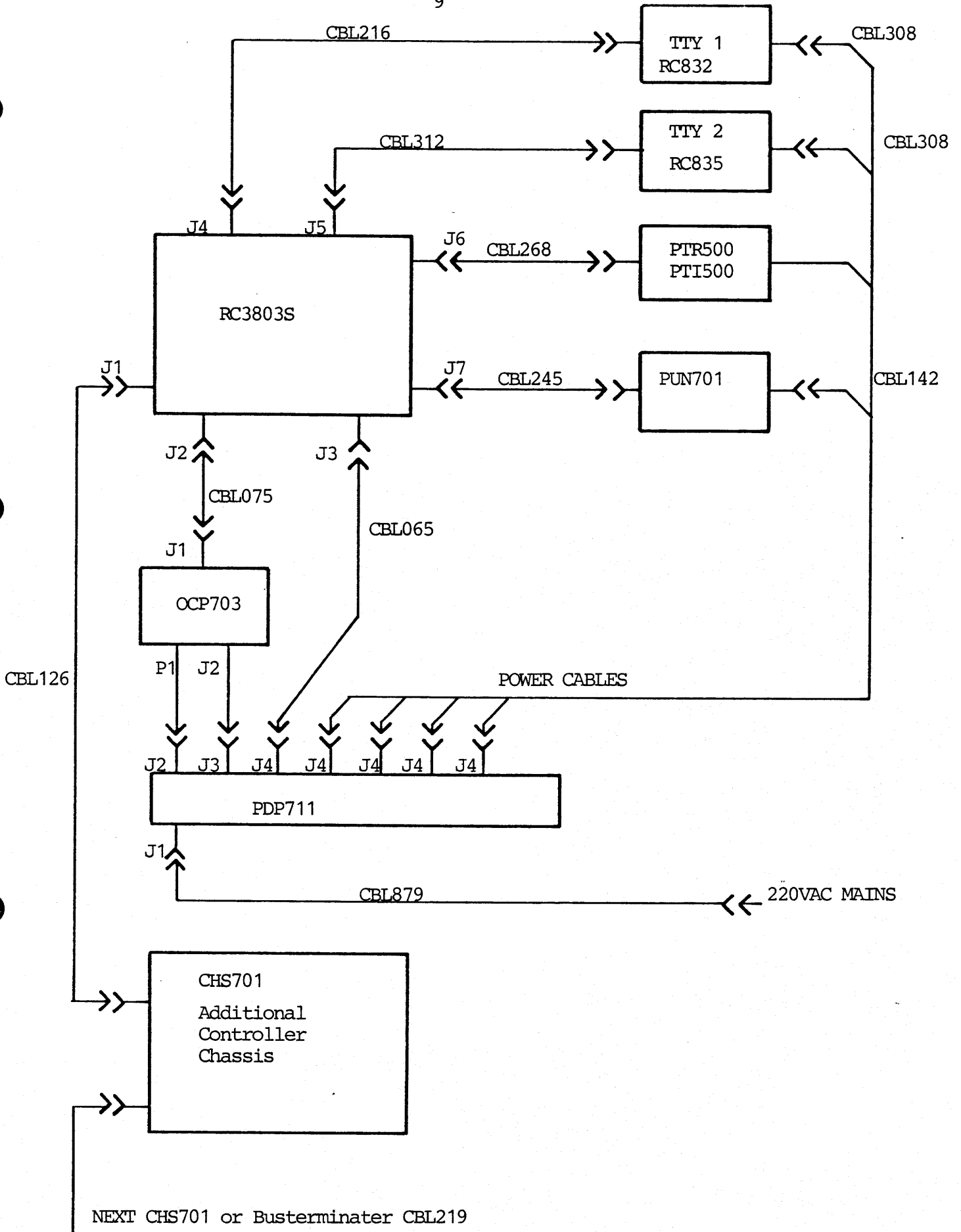

Fig. 4.4.1 Interconnection Diagram.

4.5 Installation of Program Load PROM's.

4.5

For Automatic program load, 3 PROM's must be installed on the CPU720 board:

IC position 58: ROM789

IC position 71: ROM791

IC position 81: ROM790

DIP-sockets are provided in the three positions, so installation is carried out without using soldering tool.

For details on the autoload PROM's refer to 52-AA894 "Hardwired Testprograms and Program Load to RC3803".

5. Check-Out Procedure.

5.

Upon installation the following check out procedure should be carried out.

- a. Visually inspect the cabling to insure correct interconnections.
- b. Set the Parity Error Reset switch on the CPU720 front panel in position UP. The Stop switch should be set in position DOWN. Turn on the power and check the DC voltages +5V, +12V and -12V at the top of the CHS718 chassis. The voltages should be within  $\pm 2\%$  of their nominal values. Adjust if necessary (Rear side of chassis).
- c. Verify that the indicators are lit according to the following list:

Indicator Name	Location	State
POK	Front of CHS718	ON
PINT	Rear side of CHS718	ON
FETCH	Front of CPU720	ON
DEFER	-"-	OFF
PARITY ERROR	-"-	OFF
POK	Operators Control Panel	ON
RUN	-"-	ON
AUTOLOAD	-"-	OFF
MEM.INIT.DISABLE	Front of MEM720	OFF

Activate the PINT RESET switch on the rear side of the chassis and check that the PINT indicator turns off.

Activate the MEM.INIT.DISABLE switch on the front panel of MEM720 and check that the indicator turns on.

- d. Set the Autoload Device Select switches on the CPU720 to 01 (octal). This causes the build in memory test program to be selected.

Press the AUTOLOAD push-button on the OCP703 and observe that the RUN and AUTOLOAD indicators changes state i.e. RUN is turned off and AUTOLOAD is turned on. The FETCH indicator on the CPU720 should remain lit, and the PARITY ERROR indicator should remain off.

- e. Then change the state of the Autoload Device Select switches to 02 (octal), bit 0 set, and press autoload. Now the CPU should run a character generating program, outputting 80 characters per line on the console.

A character echo program is selected if bit 0 is reset (dev. no. unchanged) and autoload is activated. The program transmits on the teletype output each character received on the teletype input.

f. Load the CPU720 extended instruction set testprogram, 52-AA900 or latest revision, and run the program succesfully for at least 8 passes (appr. 20 minutttes).

g. Load the RC3600 extended memory test, 44-RT1648 or latest revision, and run the program succesfully for at least 2 passes (appr. 40 minutttes) The program should be initialized using the following parameters:

```

Startaddress:          400
First Memory Location: 11614
Last Memory Location:  177777
Memory Type:          1

```

The message: "Miserable Timing" should be ignored.

h. If a paper tape punch is installed, run the Paper Tape Punch Reliability program. The hereby produced paper tape should be used during the execution of the Paper Tape Reader Reliability program.

If errors are detected during the above listed procedure, one or more diagnostic program may be needed in the subsequent faultfindings. In the following, applicable test program are listed:

ABS.BIN.	Document	Text.
<u>paper tape</u>		
44-RT1715	44-RT1714	RC3600 CPU Logic Test
44-RT985	44-RT983	RC3600 Checkerboard III
44-RT1625	44-RT1623	RC3600 Checkerboard IV
44-RT974	44-RT972	RC3600 Checkerboard V
44-RT1349	44-RT1353	RC3603 Exerciser
44-RT1807	44-RT1806	Testprogram for RIC702
44-RT1003	44-RT1001	Test for TIC705/TIC706
44-RT1558	44-RT1557	RC3600 Instruction timer test.
44-RT1346	44-RT1350	RC3603 Address Test



Note that most of the programs listed requires a TCP701 Diagnostic Panel to be mounted on the 1001 edge connector of the CPU720. Refer to "Programmers Reference Manual for TCP701", 52-AA542.



**RETURN LETTER**

Title: **GENEREL INFORMATION RC3803S, Rev. 0**      **RCSL No.: 44-RT1953**

A/S Regnecentralen af 1979/RC Computer A/S maintains a continual effort to improve the quality and usefulness of its publications. To do this effectively we need user feedback, your critical evaluation of this manual.

Please comment on this manual's completeness, accuracy, organization, usability, and readability:

---

---

---

---

Do you find errors in this manual? If so, specify by page.

---

---

---

---

How can this manual be improved?

---

---

---

---

Other comments?

---

---

---

---

---

Name: \_\_\_\_\_ Title: \_\_\_\_\_

Company: \_\_\_\_\_

Address: \_\_\_\_\_

Date: \_\_\_\_\_

Thank you

..... Fold here .....

..... Do not tear - Fold here and staple .....

Affix  
postage  
here

**E** **REGNECENTRALEN**  
af 1979

Information Department  
Lautrupbjerg 1  
DK-2750 Ballerup  
Denmark