

---

**RCSL No:** 44-RT2045

**Edition:** January 1983

**Author:** Mogens V. Pedersen

---

**Title:**

Keyboards for RC700/RC850

Drawings

---

---

**Keywords:**

Keyboard, RC700, RC850, KTC401, KTC402, KTC403, KTC404, KTC405,  
Keytronic, RC721, RC722, RC723.

---

**Abstract:**

These drawings contain the circuit diagrams for the keyboards manufactured by Keytronic and used by RC Computer to RC700 and RC850.

(14 printed pages)

---

<u>TABLE OF CONTENTS</u>	<u>PAGE</u>
1. GENERAL .....	1
2. CIRCUIT DIAGRAMS .....	2



1. GENERAL

1.

The keyboards to RC700 and RC850 are produced by Keytronic in USA. The keyboards are made in many different layouts but it is the same circuit board used. The RC700 keyboards are used in parallel mode, and the RC850 keyboards are used in serial mode.

Strapping for RC700:

- C21 installed (parallel mode)
- C22 not used
- C23 installed (external ASCII table)
- C24 to C28 not used

Strapping for RC850:

- C21 not used
- C22 installed (serial mode)
- C23 to C28 not used

The keyboard is also described in the manual:

- RCSL No 44-RT1980
- RC721 and RC722 Keyboards
- Technical Manual

The diagrams in this manual are the newest diagrams for the keyboards.



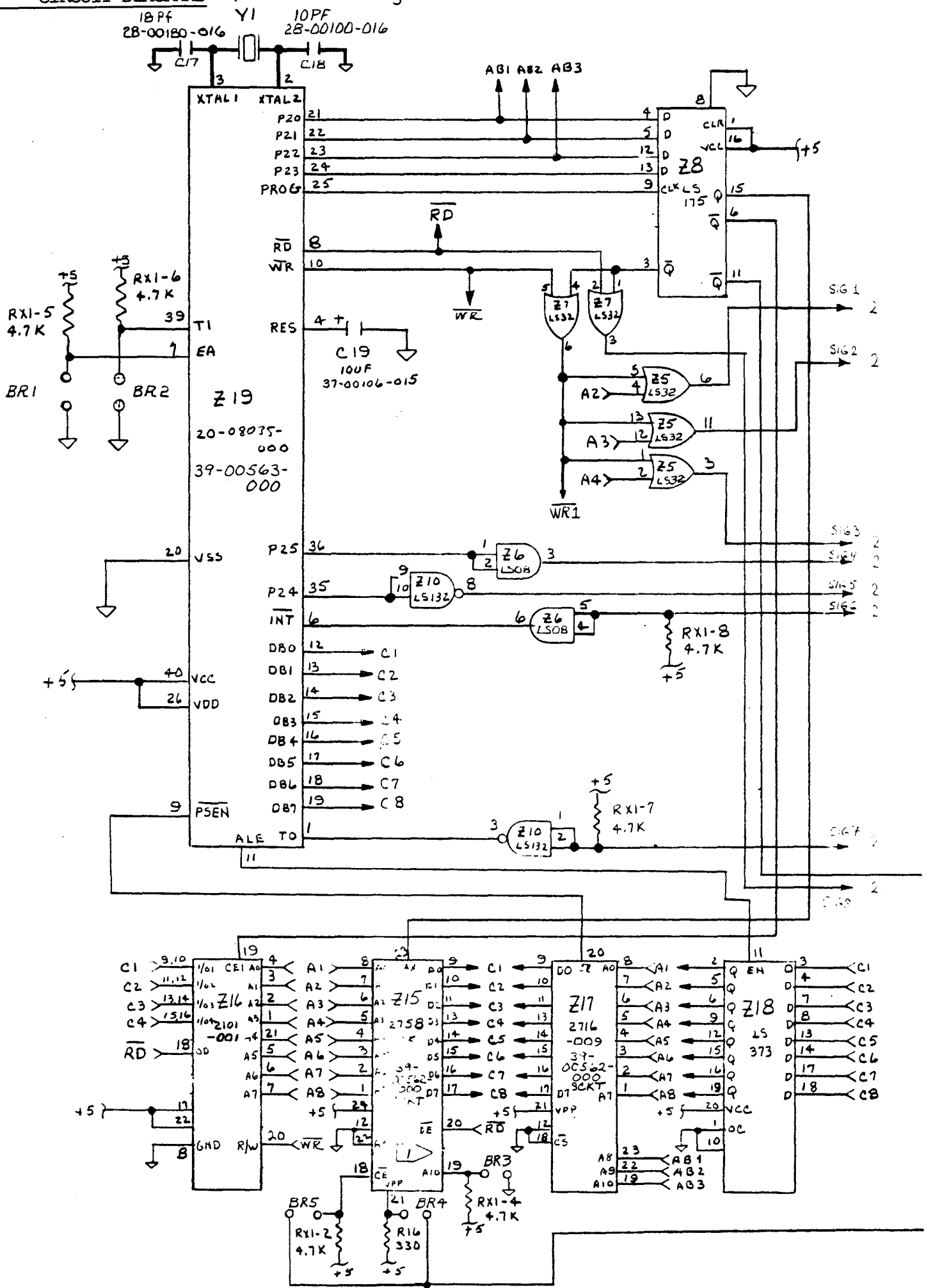





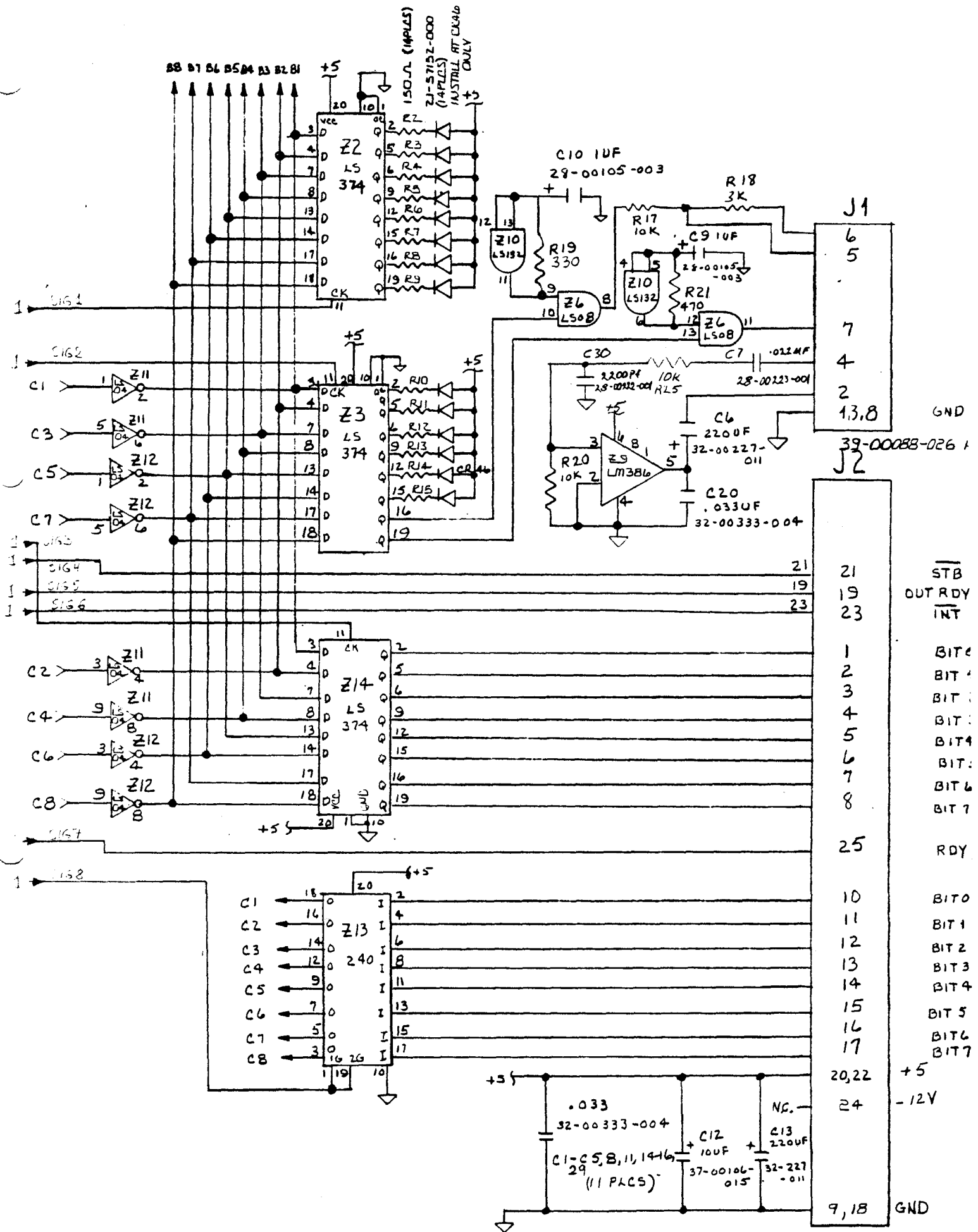
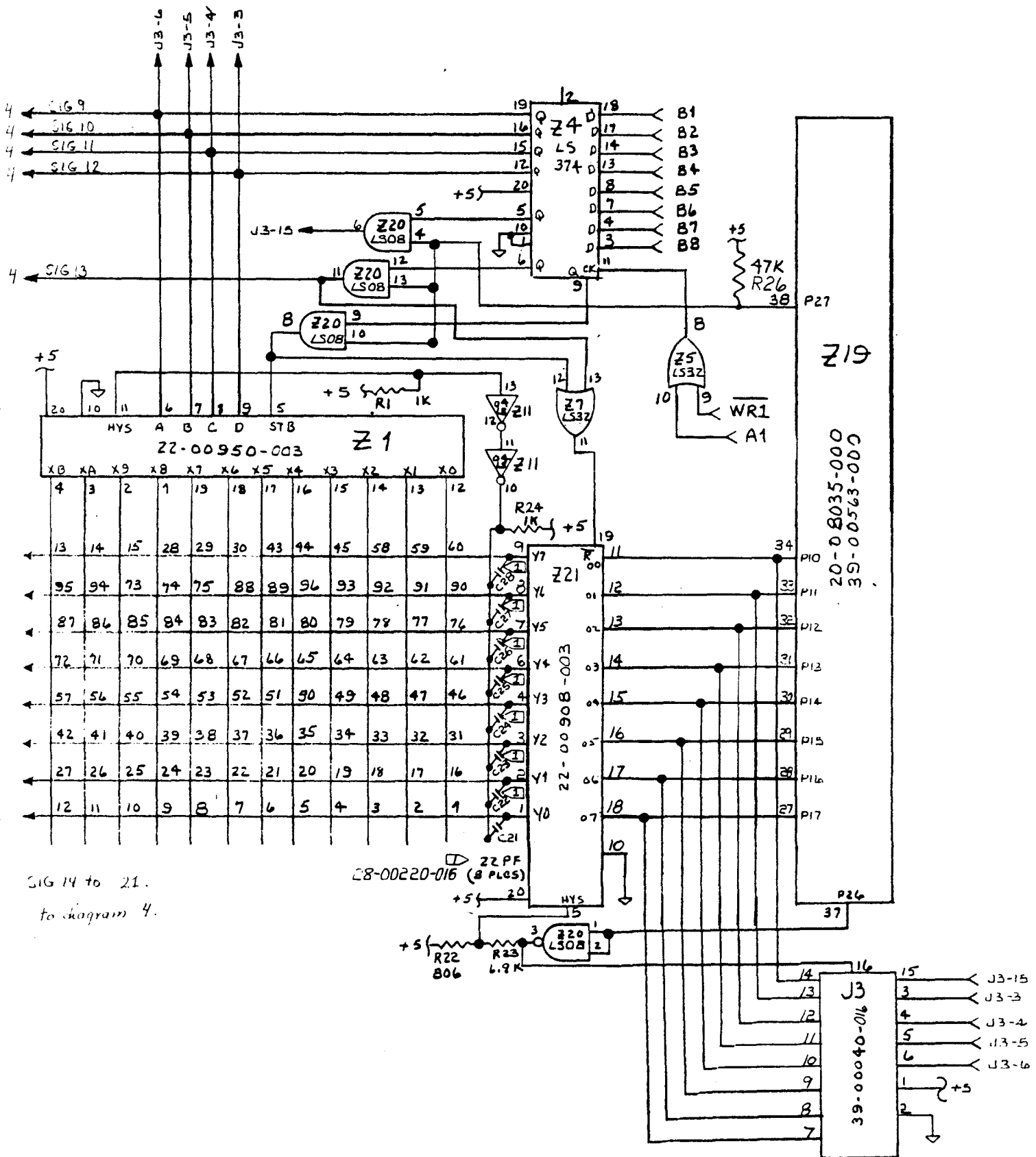

Diagram No 2: Input/output registers.





SIG 14 to 21.  
to diagram 4.

Diagram No 3: X-drivers and Y-receivers.



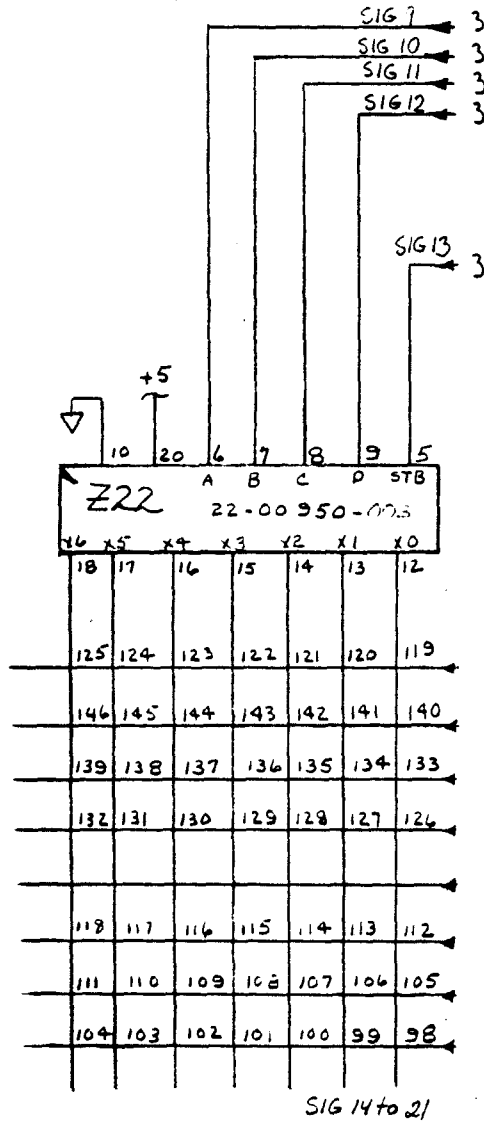

SIG 14 to 21

from page 3



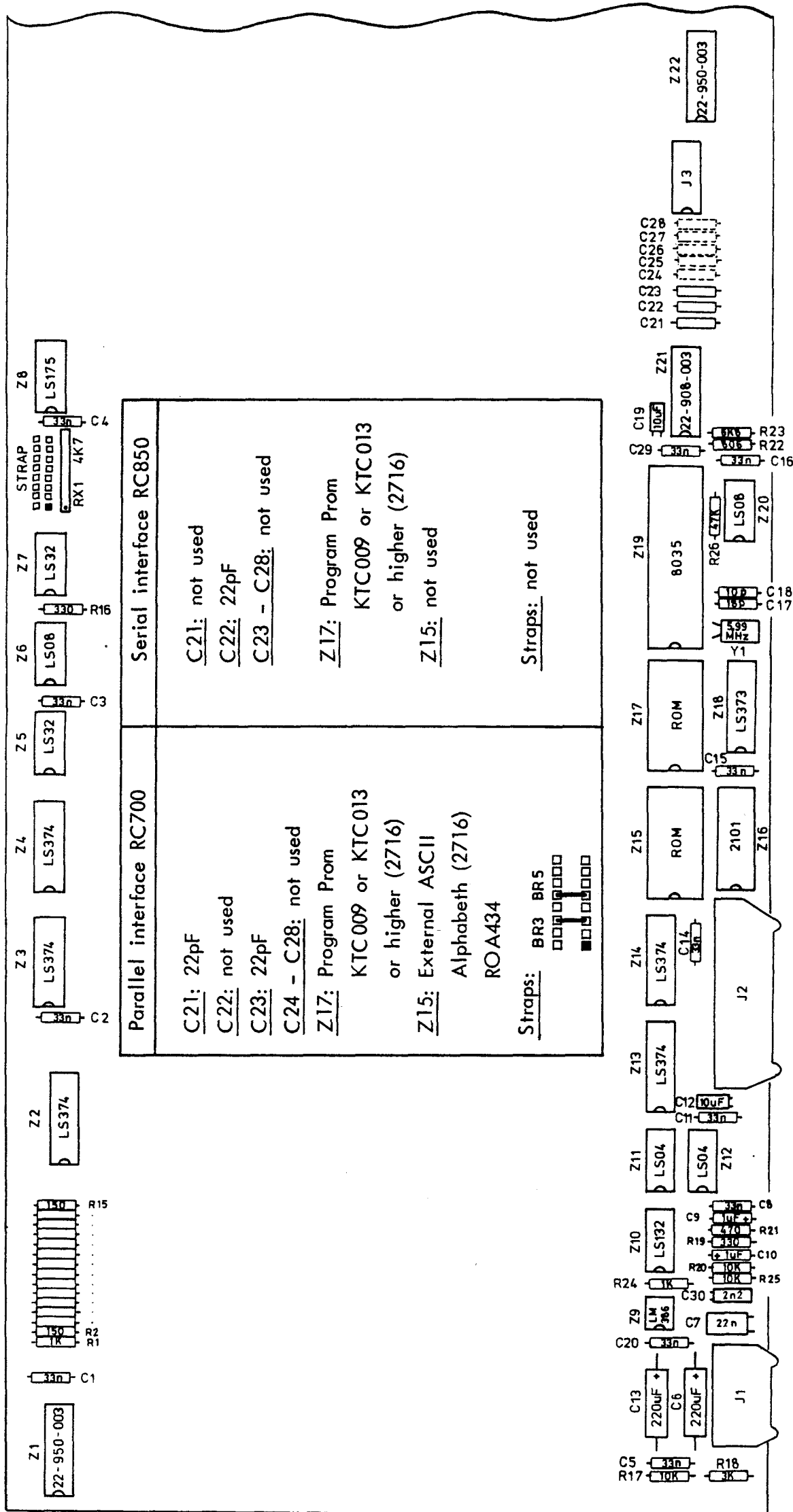

Component layout long version keyboard.





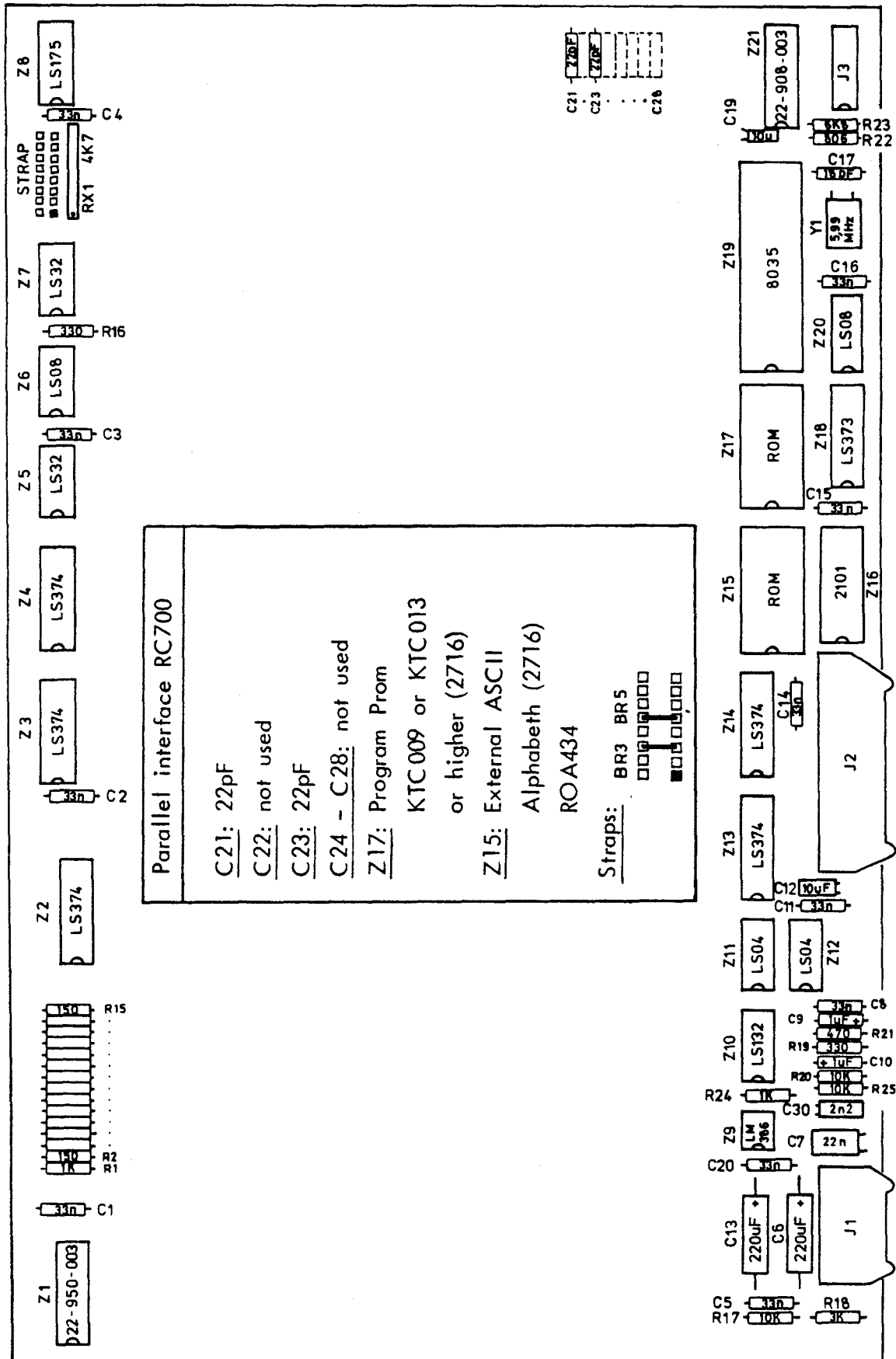

Component layout short version keyboard.



**RETURN LETTER**

Title: Keyboards for RC700/RC850  
Drawings

RCSL No.: 44-RT2045

A/S Regnecentralen af 1979/RC Computer A/S maintains a continual effort to improve the quality and usefulness of its publications. To do this effectively we need user feedback, your critical evaluation of this manual.

Please comment on this manual's completeness, accuracy, organization, usability, and readability:

---

---

---

Do you find errors in this manual? If so, specify by page.

---

---

---

How can this manual be improved?

---

---

---

Other comments?

---

---

---

---

Name: \_\_\_\_\_ Title: \_\_\_\_\_

Company: \_\_\_\_\_

Address: \_\_\_\_\_

Date: \_\_\_\_\_

Thank you

..... **Fold here** .....

..... **Do not tear - Fold here and staple** .....

Affix  
postage  
here

 **REGNECENTRALEN**  
af 1979

Information Department  
Lautrupbjerg 1  
DK-2750 Ballerup  
Denmark