

RC LOG LIST

UNIT RC610 MODEL PE200/ NO

This LOG LIST contains information on modifications of the basic unit, due to Options, Engineering Change Notes, and Field Change Orders.

Do not forget to list all future modifications on this page.

OPTION ECN or FCO No.	DATE of Installation	SIGN	SHORT DESCRIPTION
ECN 1102, 1103, 1104, 1105			



RCSL : 44-RT 201

pages

Marts 1971

LPE 200
CONTROLLER FOR CONNECTION
OF LP 200 PRINTER ON-LINE TO
RC 4000

TECHNICAL MANUAL

A/S REGNECENTRALEN
1 Falkoner Allé
Copenhagen F

CONTENTS

Section

INTRODUCTION	1
Functional Description.....	1.1
Fig. 1 HAMMER OPERATION..... Dwg. No. A20744	
OPERATIONAL DESCRIPTION.....	2
LP200 Operational Description ..	2.1
Input Character Set	2.2
PROGRAMMING.....	3
Write Command.....	3.1
Sense Command.....	3.2
OPERATION.....	4
Operators Controls and Indicators.....	4.1
Power/Operable Pushbutton Indicator.....	4.2
Remote/Local Pushbutton Indicator.....	4.3
Parity/Paper-out Indicator..	4.4
Local Start/Stop Pushbutton Indicator.....	4.5
Form mode/Line mode Pushbutton Indicator..	4.6
Testprint/Paper Feed Pushbutton Indicator.....	4.7
Operators Control Located on the Relay Box.....	4.8
Operators Control Located on the Drum Gate.....	4.9
Operators Control Located on the Paper Feed Assembly.....	4.10
Paper positioning controls(See Fig. 3)	4.10.1
Paper tensioning controls (See Fig. 3) ..	4.10.2
Copies control (See Fig. 3).....	4.10.3
Operating Procedures required for Operation of the Printer.....	4.11
Application of Power to the Printer..	4.12
Removal of Power to the Printer	4.13
Ribbon Installation (See Fig. 4) ..	4.14
Ribbon Removal	4.15
Tape Loop Preparation.....	4.16
Tape Loop Installation (See Fig. 6) ..	4.17

Contents continued	Section
Paper Loading (See Fig. 3)	4.18
Paper Tension Adjustment Without Paper Drive Releaser	4.19
Horizontal Paper Tension Adjustment	4.19.1
Vertical Paper Tension Adjustment	4.19.2
Paper Loading with Paper Drive Releaser (See Fig. 3)	4.20
Paper Tension Control with Paper Drive Releaser (See Fig. 3)	4.21
Fig. 2 OPERATORS CONTROL PANEL Dwg. No. A20752	
Fig. 3 OPERATING CONTROLS AND IND. - - A20746	
Fig. 4 RIBBON INSTALLATION AND REMOVAL - - A20747	
Fig. 5 TAPE-LOOP PREPARATION - - A20751	
Fig. 6 TAPE-LOOP READER - - A20745	
OPTIONS	5
Optional available are	5.1
PREVENTIVE MAINTENANCE	6
Cleaning	6.1
Character Drum Sleaining	6.1.1
Filter Cleaning	6.1.2
Lubrication	6.2
Ribbon Motor Lubrication	6.2.1
Tape Loop Reader Lubrication	6.2.2
Tractor Shaft Lubrication	6.2.3
Additional Lubrication Points	6.2.4
Fig. 7 LUBRICATION POINTS Dwg. No. A20750	
SPECIFICATIONS FOR CONSUMPTION GOODS	7
Paper	7.1
Ribbon	7.2
Tape	7.3
Cleaning	7.4
Lubrication	7.5
SIGNAL SPECIFICATION	8

Contents continued	Section
STANDARD ACCESSORIES	9
INPUT POWER REQUIREMENTS.....	10
Environmental Conditions.....	10.1
PHYSICAL CHARACTERISTICS.....	11
Dimensions.....	11.1
Weight.....	11.2
Installation Diagram(See Fig. 8).....	11.3
Fig. 8 INSTALLATION DIAGRAM..... Dwg. No. A20749	
PACKING, UNPACKING PROCEDURES	12

Bus Receivers	13.1
Test Information	13.2
Data Gates	13.3
Register 1 and 2	13.4
Read Only Store	13.5
Line Buffer	13.6
Parity Check	13.7
Check of Check Character	13.8
Mark Logic	13.9
Column Counter and Decoding	13.10
Index and Char. Strobe	13.11
Character Counter	13.12
Comparator	13.13
Hammer Strobe Generator	13.14
Hammer Drivers	13.15
Paper Feed and Hammer Power Supply	13.16
Hammer Bank	13.17
Print Control Logic	13.18
Speed	13.19
Echo	13.20
Paper Out and Drum Gate Open	13.21
Paper Feed Control Logic	13.22
Paper Control Register	13.23
Tape Loop Register	13.24
Strobe Generator	13.25
Paper Feed Servo And Power Amplifier	13.26
Time Out	13.27
Bus Receivers.....	13.28
DEV. Connected and DEV. Ready	13.29
Bus Receivers	13.30

Contents continued		Section
Command and Address Decoding		13.31
Interrupt and Status Logic		13.32
Clock and Timing		13.33
Basic Control Logic		13.34
Control Character Decoding		13.35
n-Logic and n-Reg.		13.36
Pushbutton Logic		13.37
Operators Control Indicators		13.38
External Indicator		13.39
Indicator Logic		13.40
FLOW CHARTS		
FC 1 FLOWCHART SURVEY	Dwg. No. A10529	
FC 2 PUSHBUTTON LOGIC	- - A10530	
FC 3 PAPER FEED LOCAL	- - A10531	
FC 4 START OF LOAD	- - A10532	
FC 5 LOAD	- - A10533	
FC 6 LOAD	- - A10534	
FC 7 END OF LOAD	- - A10535	
FC 8 PRINT	- - A10536	
FC 9 PRINT	- - A10537	
FC 10 PRINT	- - A10538	
FC 11 PAPER FEED	- - A10539	
FC 12 PAPER FEED	- - A10540	
FC 13 PAPER FEED	- - A10541	
FC 14 POWER ON/OFF SEQUENCE	- - A10542	
FC 15 POWER ON/OFF SEQUENCE	- - A10543	
FC 16 POWER ON/OFF SEQUENCE	- - A10544	
TIMING CHARTS		
TC 1 SURVEY TIMING CHART	- - A10474	
TC 2 SENSE COMMAND	- - A10475	
TC 3 LOADING ON LINE SURVEY	- - A10476	

TC 4 I/O WRITE COMMAND	Dwg. No.	A10477	
TC 5 I/O WRITE COMMAND CONTINUED	-	-	A10478
TC 6 I/O WRITE COMMAND CONTINUED	-	-	A10479
TC 7 CLOCK AND TIMING GENERATOR	-	-	A10480
TC 8 CHARACTER COUNTER	-	-	A10481
TC 9 CHAR STR SYNC AND START SPEED CHECK	-	-	A10482
TC 10 START PRINTING	-	-	A10483
TC 11 PRINTING CONTINUED	-	-	A10484
TC 12 PRINTING CONTINUED	-	-	A10485
TC 13 TERMINATION OF PRINTING	-	-	A10486
TC 14 ECHO CHECK	-	-	A10487
TC 15 TERMINATION OF ECHO CHECK	-	-	A10488
TC 16 TAPE MODE PAPER FEED	-	-	A10489
TC 17 COUNT MODE PAPER FEED	-	-	A10490
TC 18 ONE LINE STEPPING	-	-	A10491
TC 19 TWO LINE STEPPING	-	-	A10492
TC 20 THREE LINE STEPPING	-	-	A10493
LOGIC DIAGRAMS			14
Fig. 9 CONTROL LOGIC	Dwg. No.	A10404	
Fig. 10 DATA IN	-	-	A10403
Fig. 11 PRINT	-	-	A10405
Fig. 12 PAPER FEED	-	-	A10406
LD 1 BUS RECEIVERS	-	-	A10333
LD 2 BUS RECEIVERS 10-16	-	-	A10334
LD 3 BUS RECEIVERS 17-23	-	-	A10335
LD 4 COMMAND AND ADDRESS DECODING ..	-	-	A10336
LD 5 COMMAND AND ADDRESS DECODING ..	-	-	A10337
LD 6 DEV READY AND DEV CONNECTED	-	-	A10338
LD 7 INTERRUPT LOGIC AND STATUS LOGIC .	-	-	A10339
LD 8 EXTERNAL REMOTE-LOCAL INDICATION	-	-	A10340
LD 9 PUSHBUTTON LOGIC	-	-	A10341

Contents continued

LD 10 PUSHBUTTON LOGIC	Dwg. No.	A10342
LD 11 PUSHBUTTON LOGIC	- -	A10343
LD 12 PUSHBUTTON LOGIC	- -	A10344
LD 13 PUSHBUTTON LOGIC	- -	A10345
LD 14 OPERATOR CONTROL AND IND.LOGIC .	- -	A10346
LD 15 OPERATOR CONTROL AND IND.LOGIC .	- -	A10347
LD 16 CLOCK AND TIMING CIRCUITS	- -	A10348
LD 17 CLOCK AND TIMING CIRCUITS	- -	A10349
LD 18 BASIC CONTROL LOGIC	- -	A10350
LD 19 BASIC CONTROL LOGIC	- -	A10351
LD 20 BASIC CONTROL LOGIC	- -	A10352
LD 21 BASIC CONTROL LOGIC	- -	A10353
LD 22 TEST INFORMATION	- -	A10354
LD 23 REGISTER 1 AND REGISTER 2	- -	A10355
LD 24 REGISTER 1 AND REGISTER 2	- -	A10356
LD 25 REGISTER 1 AND REGISTER 2	- -	A10357
LD 26 n-REGISTER	- -	A10358
LD 27 READ ONLY STORE	- -	A10359
NOTE: INPUT CODE TABLE RC STAN-		
DARD INCL. OPTIONS.		
LD 27 READ ONLY STORE	- -	A10360
NOTE: INPUT CODE TABLE, RC		
STANDARD INCL. OPTIONS .		
LD 28 READ ONLY STORE	- -	A10361
LD 29 READ ONLY STORE	- -	A10362
NOTE: INPUT CODE TABLE,		
RC STANDARD INCL. OPTIONS.		
LD 30 READ ONLY STORE	- -	A10363
NOTE: INPUT CODE TABLE,		
RC STANDARD.		

Contents continued

LD 30 READ ONLY STORE		Dwg. No. A10364
NOTE: INPUT CODE TABLE, RC STANDARD INCL. OPTIONS.		
LD 31 LINE BUFFER (SHIFT REGISTER)	- -	A10365
LD 32 CONTROL CHARACTER DECODING	- -	A10366
LD 33 CONTROL CHARACTER DECODING	- -	A10445
LD 34 CONTROL CHARACTER DECODING	- -	A10446
LD 35 CONTROL CHARACTER DECODING	- -	A10369
LD 36 CONTROL CHARACTER DECODING	- -	A10370
LD 37 COLUMN COUNTER	- -	A10371
LD 38 COLUMN COUNTER DECODING	- -	A10372
LD 39 COLUMN COUNTER DECODING	- -	A10373
LD 40 PRINT CONTROL LOGIC	- -	A10374
LD 41 PRINT CONTROL LOGIC	- -	A10375
LD 42 MARK LOGIC	- -	A10376
LD 43 INDEX AND CHAR. COUNT LOGIC	- -	A10377
LD 44 INDEX AND CHAR. COUNT LOGIC	- -	A10378
LD 45 INDEX AND CHAR. COUNT LOGIC	- -	A10379
LD 46 CHARACTER COUNTER	- -	A10380
LD 47 COMPARATOR	- -	A10381
LD 48 HAMMER STROBE GENERATOR	- -	A10382
LD 49 PAPER FEED CONTROL LOGIC	- -	A10383
LD 50 PAPER FEED CONTROL LOGIC	- -	A10384
LD 51 PAPER CONTROL REGISTER	- -	A10385
LD 52 PAPER FEED SERVO AMP. AND PAPER FEED POWER AMP.	- -	A10386
LD 53 TAPE LOOP REGISTER	- -	A10387
LD 54 TAPE LOOP REGISTER	- -	A10388
LD 55 TAPE LOOP REGISTER	- -	A10389
LD 56 MCL CIRCUITS	- -	A10390
LD 57 PARITY CHECK	- -	A10391

LD 58 CHECK CHAR. ERROR AND SPEED ERROR	Dwg. No. A10392	
LD 59 TIME OUT CIRCUITS	- - A10393	
LD 60 PAPER OUT DRUM GATE OPEN	- - A10654	
LD 61 INDICATOR LOGIC	- - A10395	
LD 62 ECHO SELECTION	- - A10396	
LD 63 ECHO COUNTER	- - A10397	
LD 64 ECHO ERRORS	- - A10398	
LD 65 HAMMER DRIVERS	- - A10399	
LD 66 HAMMER DRIVERS	- - A10400	
LD 67 HAMMER DRIVERS	- - A10401	
LD 68 HAMMER DRIVERS	- - A10402	
LD 69 POWER ON SEQUENCER 1	- - R10082	
LD 70 POWER ON SEQUENCER 2	- - R10083	
LD 71 MULTI AND +5V SUPERVISION	- - A10459	
LD 72 +50V, +35V, -35V SUPERVISION	- - A10460	
LD73 P18, P1562	- - A10655	
LD 74 P19, P1563, J1564, J1565	- - A10468	
WIRING DIAGRAM		15
Fig. 13 BLOCK DIAGRAM, AC POWER	Dwg. No. A10461	
PHYSICAL DESCRIPTION		16
RC 610 LINE/PRINTER		16.1
Printer Chassis		16.2
Electronics Gate		16.3
Electronic and Mechanic Parts		16.4
LPE 200		16.5
LP 200		16.6
LPE 200 Parts		16.7
CARD CAGE 100-500		16.8
5VOLTS POWER SUPPLY		16.9
MULTI POWER SUPPLY		16.10
PAPER FEED POWER AMP.		16.11

MAINTENANCE PANEL	16.12
ELECTRONICS GATE FANS	16.13
RELAY BOX	16.14
PAPER FEED AND HAMMER POWER SUPPLY	16.15
CAPACITOR BANK	16.16
DRIVE MOTOR BLOWER AND HAMMER BANK BLOWER	16.17
OPERATOR CONTROL PANEL	16.18
RIBBON CONTROL LOGIC	16.19
PICK-UP AMPS AND PHASE CONTROL	16.20
LP 200 PARTS	16.21
Fig. 14 PRINTER CHASSIS PRIMARY ASSEMBLIES Dwg. No. A20743	
Fig. 15 ELECTRONICS GATE MAJOR ASSEMBL. - - A20754	
Fig. 16 MAINTENANCE PANEL	- - A20755
PCB SURVEY	17
Fig. 17 PCB SURVEY	Dwg. No. R10091
EXTERNAL AND INTERNAL CABLING	18
Fig. 18 EXTERNAL CABLES	Dwg. No. A20756
Fig. 19 INTERNAL CABLING	- - A10527
JACKLISTS	
J1490	Dwg. No. A20658
J1490	- - A20659
J1491	- - A20660
J1491	- - A20661
J1499	- - A20662
J1560	- - A20665
J1560	- - A20666
J1561	- - A20669
J1561	- - A20670
J1562	- - A20671
J1562	- - A20905

J1563	Dwg. No. A20673	
J1566	- -	A20675
PLUGLISTS		
P1490	Dwg. No. A20656	
P1490	- -	A20657
P1560	- -	A20663
P1560	- -	A20664
P1561	- -	A20667
P1561	- -	A20668
P1564	- -	A20674
P1567	- -	A20676
P1568	- -	A20677
LIST OF NAMES AND SHORT DESCRIPTION OF SIGNALS		19
CONTROL AND ADJUSTMENT INTRODUCTION		20
Maintenance Panel		20.1
Off Line Operation		20.2
Form Feed		20.3
Line Feed		20.4
Quick Loading and One Line Printing of All the Same Character		20.5
Quick Loading and Continuous Printing of All the Same Character		20.6
Character Loading and One Line Printing		20.7
Character Loading and Continuous Printing		20.8
Tape Loop Phase Adjustments		20.9
Hammer Bank Alignments		20.10
Hammer Flight Time Adjustment (see Fig. 14)		20.11
Power Supply Adjustments		20.12
Character Drum Phasing (see Fig. 15)		20.13
Phasing Control Adjustment		20.14
Internal Phasing Control Adjustment		20.15
Count Wheel Phasing Adjustment		20.16
Index Pin Alignment		20.17

RC 3065-1..	Dwg. No. A20266	
	- - A20534	
RC 3067-1.....	- - A10148	
	- - A10149	
	- - A10150	
	- - A20580	
RC 3069-1.....	- - A10146	
	- - A20532	
RC 3096-1..	- - A20901	
	- - A20903	
RCLM400.....	RCSL: No.44-RT 172	24
LP200(d/p MANUAL).....		25

pp. :1-1:1-2(AA 158), 2-1:4-17(AA 158), 5-1:6-5(AA 158), 7-1:11-1(AA 158),
 12-1(AA 158), 13-1:13-17(AA 159), 16-1:16-4(AA 159), 19-1:20-11(AA 159)

INTRODUCTION

1

This paper describes the RC610 LINE PRINTER which consists of:

1. LPE 200 Control electronic
2. LP 200 Print mechanism.

The description will mainly deal with the LPE 200 designed and manufactured by A/S REGNECENTRALEN.

The LP 200 is a DATA PRODUCTS printmechanism MODEL dp/p - 4300 designed and manufactured by DATA PRODUCTS CORPORATION, 8535 WARNER DRIVE, CULVER CITY, CALIFORNIA.

For further information on LP 200 see section 25.

Functional Description

1.1

The RC610 LINE/PRINTER contains all the electronic and mechanical components required to accept and store one line of data from RC4000 serial by character (up to a maximum of 132 characters), print the line on multiple-part fanfold paper or on tabulating stock, and move the paper to the position corresponding to the next print line.

The RC610 LINE/PRINTER utilizes a continuously rotating drum on which characters are arranged in horizontal rows, the number of rows being determined by the number of characters in the character set. Each vertical column about the circumference of the drum thus contains all the characters in the set, and the number of columns defines the maximum number of characters per line. Each character is stored in a one-line shift register buffer arranged as a cyclic store, when the store is loaded a character address location corresponds to the column in which it will be printed. Printing is accomplished by shifting in the cyclic store in synchronism with the rotating characters and actuating a hammer (see Fig. 1) associated with the address location, when the proper character approaches the print position.

The line of data stored in the buffer is shifted one character at a time to the first position of the cyclic store and compared with the drum character approaching the print position. If the drum character currently in the printing position is A, the logic will sequentially fire the appropriate hammers to print all the A-s in the stored line of data. As the drum rotates each character in the buffer is compared with each successive drum character as it comes into printing position. In one revolution or less of the character drum, the entire line of data will be printed.

010769 IBP-VH 280170 LLM 110270 JA 200370 IBP

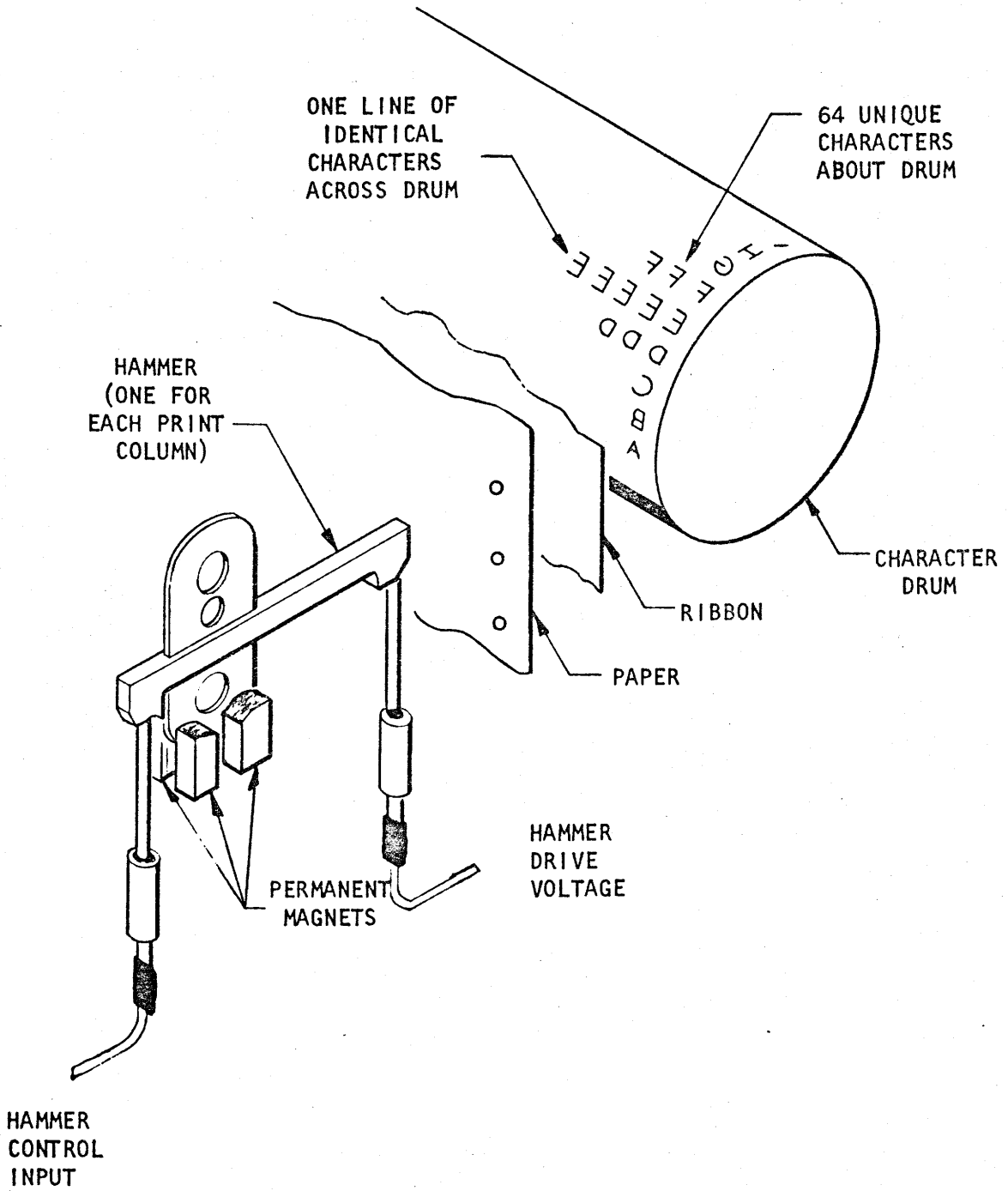

LPE 200

A20744

HAMMER OPERATION

Figure

Fig 1

The LP 200 (printer mechanism) is connected to the low speed data channel via LPE 200 (control electronic) which buffers one line.

LP200 Operational Description

2.1

The LP 200 is a drum type print mechanism with the following general specifications:

Printing rate	Up to 1000 lines-per-minute.
Characters per line	Up to 132.
Characters per inch	10.
Lines per inch	6.
Line to Line Spacing	0.167 (\pm 0.010) inch.
Character Sets	64 and 96 standard.
Character Drum Speed	1000/667 rpm minimum for 64/96 character drum.
Paper Feed	Tractor type, using a pair of pin-feed tractors above a pair of tractors below the print position.
Paper Speeds	One line - 15 msec max. two lines - 25 msec max. three lines - 30 msec max. 5 msec per line after third corresponding to max. paper feed speed 35 inches per second.
Paper Feed Control	The paper feed may be controlled either by a 8 channel format tape or by counting lines.

Paper Format

19 inches maximum width, prints on 13.2 inch width in the center of a 19 inch form.

Paper Dimensions

Standard edge-punched 1/2 inch centers fanfold paper from 4.5 to 19 inches in width.

Paper Types

Up to six parts, 12-pound bond (single copy minimum weight, 15 pound bond); or a tabulating card (0.007 inch) plus a second record sheet.

Paper Loading

Drum gate pivots outward through an opening between the ribbon mask and the hammer bank.

Horizontal Alignment

LEFT TRACTOR DETENTS. Upper and lower left tractors are individually positioned by detents to coarse define location of left-hand paper holes.

FORM WIDTH ADJUSTMENT. Upper and lower right tractors are individually positioned by lock-nuts to align tractors with right hand paper holes. Adjustable for 4-1/2 inch to 19 inch forms.

HORIZONTAL PAPER TENSION ADJUSTMENT. Individual adjustments on upper and lower right-hand tractors to provide proper horizontal paper tension.

HORIZONTAL PAPER POSITION ADJUSTMENT. Provides vernier adjustment of all four tractors to horizontally align forms while printing.

Vertical Alignment

VERTICAL PAPER TENSION ADJUSTMENT. Varies distance between upper and lower tractor pairs to provide proper vertical paper tensioning.

VERTICAL PAPER POSITION ADJUSTMENT. Adjusts paper vertically ± 1 line from its mid-range position.

Character Typeface

On the standard drums, 64 and 96 characters, OCR-B font is used except for the basis of ten characters.

Character Spacing

Horizontal character spacing is 0.100 (± 0.005) inch between centers. The maximum cumulative error is no more than ± 0.010 inch per 132 character line.

Line Straightness

No character deviates more than ± 0.010 inch from a straight line drawn parallel to the line of characters.

Input Character Set

2.2

The standard character set is a subset of the ISO 7 bit character set. Two standard print drums are available. One having 64 graphics capital letters only, the other having 96 graphics including small letters. 4 (optionally 9) control characters are used.

The characters are internally represented by the bits

b7 b6 b5 b4 b3 b2 b1

having the weights

64 32 16 8 4 2 1

In the code table columns and rows are indentified by decimal equivalents of the binary numbers:

```

column: b7  b6  b5  0  0  0  0
row:      0  0  0  b4  b3  b2  b1

```

The decimal value of a character code is thus the sum of column and row numbers. Empty positions in the table are characters which are not used with the printer.

The character set is divided in control characters, columns 0 and 16, and graphical characters, columns 32 to 112. The table shows the assignment of characters according to the ISO recommendation for the two standard print drums with 64 and 96 characters respectively. Other print drums with expanded character sets may be supplied. Characters which are not assigned by the ISO-standard will be reached by means of the shift option. After having received the character SHIFT OUT, the printer will interpret the character codes to be in a new set of graphical characters. Control characters, columns 0 and 16 have the same meaning while column 32 is reserved for a standard expansion of the graphics set. This assignment of codes will remain valid until the character SHIFT IN is received, thus returning control to the standard character set.

The two standard print drums differ only in the respect that the big one also has small letters. Both have a set of national letters so that it is possible to construct 3 varieties of alphabets: danish, german, and swedish. In these the rows 11, 12, and 13 of columns 80 and 112 are assigned as follows:

	Danish	German	Swedish
11	Æ æ	Ä ä	Å å
12	Ø ø	Ö ö	Ö ö
13	Å å	Ü ü	Å å

The characters not used nationally are available after shift out, column 32. The choice of national characters in the shift in alphabet is done prior to the installation.

Control Characters

The control characters have the meanings:

- CR Carriage Return, causes the printing of the line buffer contents followed by a return of print position to the beginning of the same line.
- FF Form Feed, causes the printing of the line buffer followed by a paper feed to the first line of the next form as indicated by format control tape track 0. The print position is moved to first position of this line.
- NL New Line, causes printing of a line followed by paper feed of one line. Print position is moved to first position of this line.
- VT Vertical Tabulation, causes printing of a line followed by paper feed controlled by the format control tape track 1. Print position is moved to first position of this line.

After shift in

	0	16	32	48	64	80	96	112
0			SPACE	0		P		p
1			!	1	A	Q	a	q
2			"	2	B	R	b	r
3				3	C	S	c	s
4				4	D	T	d	t
5			%	5	E	U	e	u
6			&	6	F	V	f	v
7			'	7	G	W	g	w
8		CAN	(8	H	X	h	x
9	HT)	9	I	Y	i	y
10	NL		*	:	J	Z	j	z
11	VT	ESC	+	;	K	nat.	k	nat.
12	FF		,	<	L	nat.	l	nat.
13	CR		-	=	M	nat.	m	nat.
14	SO		.	>	N		n	
15	SI		/	?	O	-	o	DEL

200370 IBP

After shift out

	0	16	32	48	64	80	96	112
0			SPACE	0				
1			Ä	1				
2			Ö	2				
3			U	3				
4				4				
5			Œ	5				
6				6				
7			Æ	7				
8		CAN	Ø	8				
9	HT		Å	9				
10	NL		ä	10				
11	VT	ESC	ö					
12	FF		ü					
13	CR		æ					
14	SO		ø					
15	SI		å					DEL

200370 IBP 200370 LLM 200370 JA

Note underline is placed on the base-line.

PROGRAMMING

3

Write Command

3.1

A write command initiates the output of one character from a working register. The contents of a working register is interpreted as follows:

irrelevant	character
0 : 16	17 : 23

After the write command the printer will be busy for approximately 12 uS (from I/O ACTIVATE), if a graphic character is transferred. If printing is started the printer will be busy until completion of the printing, which will generally not exceed 100 mS (depending on size of print drum, characters actually printed etc.).

When the line buffer is full, further graphical characters will be lost. Printing will not start until initiated by a control character.

Characters which are not defined to have any effect with the printer are ignored.

An interrupt signal is sent upon completion of the printing.

The printer has a LOCAL/REMOTE switch. In remote state the printer is program controlled. In local state the operator may insert and adjust forms etc.

If the operator switches to local during printing the transition to local status is delayed until the printing has been completed. In local status the printer accepts write commands until a control character, which causes printing, is received. When the control character is received the printer goes busy. No mechanical operation, however, is executed until the operator switches to remote status.

Sense Command

3.2

When the printer is available a sense command may be used to transfer a status word to a working register. The status holds the following information:

status zero
0 : 5 6 : 23

The status bits are:

- 0 Intervention by operator
- 1 PARITY
- 2 Time out
- 3 not used
- 4 not used
- 5 Intervention required.

The Intervention by operator is set to logical 1 when the printer goes local, and remains logical 1 until next write command is received.

PARITY is set to logical 1 if any of the following conditions is received.

- 1. Parity error in the converter
- 2. Parity error in the line buffer
- 3. Check character error i.e. shifting in the line buffer was incorrect.
- 4. Echo error i.e. one or more hammers have failed.

The parity status bit remains logical 1 until next write command.

The Time out bit is set to logical 1 if any of the following conditions occur:

- 1. Echo from hammers too long
- 2. Character Drum off speed
- 3. A paper feed operation has lasted too long
- 4. A print operation has lasted too long.

The time out bit remains logical 1 until cleared by Master clear.

Intervention required is set to logical 1 if the end of paper is reached, paper torn or drum gate open. The intervention required bit remains logical 1 until paper is corrected and drum gate closed. If the printer detects a paper out situation during printing, the line in progress will be completed.

OPERATION

4

This section describes the operating controls and the procedures required for operation of the line printer.

Operators Controls and Indicators

4.1

The following describes the various operators controls and indicators. These controls are located on the operator panel, the relay box, the drum gate, and the paper feed assembly.

Operators controls located on the operators control panel:

(See Fig. 2).

Power/Operable Pushbutton Indicator

The Power/Operable pushbutton indicator is a dual indicator switch which controls the ac-power to the printer. The switch is the push-to-set, push-to-reset type. When the switch is depressed to apply power, the power portion of the indicator lights. When the switch is depressed to remove power, the power indicator extinguishes.

The operable indicator is illuminated presupposed:

1. DEVICE CONNECTED
(i.e. all power supplies ok)
2. Paper correctly installed
3. Drum gate closed
4. No Time-out signal present.

The signals involved in the operable indicator is interpreted as follows:

1. Device connected

Device connected will be set to logical 0 and the operable indicator extinguished if any of the following conditions occurs:

- a. Multi-power supply not ok
- b. Hammer and Paper feed power supply not ok
- c. Hammer current reference voltage not ok.

When the Power switch has been activated to apply power, it will last approximately 16 seconds before Device connected becomes logical 1.

If Device connected is set to logical 0 due to power failure the situation is only resettable by turning power off and then on again, but this should not be done unless qualified service-personnel has been notified.

2. Paper out

If the printer detects a Paper out situation during printing the line in progress will be completed.

The operable indicator will be extinguished and the Paper out indicator lighted when the paper out situation occur.

The operable indicator will be lighted and the paper out indicator extinguished when the paper is corrected.

Status bit 5 is logical 1 as long as the Paper out situation exists.

3. Drum gate open

If the drum gate is left open or opened during operation, hammer strobe will be inhibited immediately. Simultaneously the status bit 5 is set to logical 1 and the operable indicator extinguished. Status bit 5 will be set to logical 0 and the operable indicator lighted, when the drum gate is closed.

CAUTION

Do not open drum gate during printing.

4. Time-out

Operable indicator is extinguished and status bit 2 set to logical 1 if any of the following conditions occurs:

- a. Hammer echo too long
- b. Drum speed
- c. Error in Paper drive motor voltage (forward voltage in too long time or too much reverse voltage)
- d. Print-cycle.

The Time out signal inhibits the hammer strobe and if c is the case the paper feed power amplifier will be disabled.

The time out signal is only resetable by means of the MCL-button, this is done because the time out error is a rather serious error, and the MCL-button should not be activated unless qualified service-personnel has been notified.

Remote/Local pushbutton Indicator

4.3

The Remote/Local pushbutton indicator is a dual indicator switch. The switch is the push-to-set, push-to-reset type. In remote state the printer is program controlled. In the local state the operator may insert and adjust forms etc.

If the operator switches to local during printing the transition to local is delayed until the printing has been completed.

In this situation the remote indicator is extinguished when the pushbutton is depressed, the local indicator, however, is not lighted until the printing has been completed.

In local status the printer accepts write commands until a control character, which demands printing, is received. When control character is received the printer goes busy. No mechanical operation however, is executed until the operator switches to remote status. The Remote/Local indicator gives the following information. Light in an indicator is equal to logical 1:

Remote indicator	Local indicator	
0	0	Local wanted
0	1	Local state
1	0	Remote state
1	1	Remote wanted

Parity/Paper-out Indicator

4.4

The Parity/Paper-out indicator is a dual indicator.

The parity portion of the indicator will be lighted if any of the following conditions occur:

1. Parity error in the converter
2. Parity error in the line buffer
3. Check character error i.e. shifting in the line buffer was incorrect.
4. Echo error i.e. one or more hammers have failed.

The parity indicator is extinguished when a new write command, concerning the printer, is executed.

The signals involved in the Parity indicator is interpreted as follows:

1. Parity error in the converter.

As soon as a character is sent to the LPE 200 it will be converted to an internal character representation by means of a read-only-store, if a parity error in the output from the read-only-store is present, the Parity indicator will be lighted, the status bit 1 set to logical 1, and the character ignored.

If a new write command is ordered the Parity indicator will be extinguished and the status bit 1 set to logical 0.

2. Parity error in the line buffer

The parity indicator is lighted and the status bit 1 set to logical 1, when a parity error in the line buffer is detected, however, the line in progress will be completed.

The parity check takes place during the entire print-cycle regardless to whether the character with wrong parity has been printed or not, and characters with wrong parity inhibit hammer strobe, i.e. they are not printed. This means that if the character should have been printed, there will be no echo from the hammer and at the end of the printing the column counter will contain the address of the line buffer cell with wrong parity.

The Parity indicator is extinguished, the status bit 1 set to logical 0, and the column counter reset when a new write command is ordered.

3. Check character error

The check character is used to check if shifting in the line buffer takes place correctly.

If a check character error is detected the Parity indicator will be lighted and the status bit 1 set to logical 1, however, the line in progress will be completed.

The Parity indicator is extinguished, the status bit 1 set to logical 0 when a new write command is ordered.

4. Echo error

If a hammer has failed to print in a column which should have been printed or a hammer has printed in a column which should not have been printed, the Parity indicator will be lighted and the status bit 1 set to logical 1.

The address of the hammer which failed will be present in the column counter after printing.

The Parity indicator is extinguished, the status bit 1 set to logical 0, and the column counter reset when a new write command is ordered.

Refer to 4.2 for the description of the Paper-out portion of the Parity/Paper-out indicator.

Over Temp., Hammer current indicator

Over Temp., Hammer current indicator is a single indicator.

The indicator is lighted and Hammer-Paper feed power supply disabled if any of the following conditions occurs:

1. Hammer current has been on for more than 400 mS
2. Over temperature in the paper drive motor.

Also an audio signal is given in these situations. The loud speaker is located on the operators control panel.

The error situation is only resetable by turning power off and then on again, but this should not be done unless qualified service-personnel has been notified.

Local Start/Stop Pushbutton Indicator

4.5

The Local Start/Stop pushbutton indicator is a dual indicator switch which starts and stops local operations.

The switch is the push-to-set, push-to-reset type.

The type of local operation executed when the pushbutton is activated is under control of the Form mode/Line mode switch, and the Testprint/Paper feed switch.

The Form mode/Line mode switch and the Testprint/Paper feed switch will normally be locked in the Form mode and Paper feed positions indicated by light in the Form mode and Paper feed portions of these indicators.

The switches are locked by means of the On line/Off line switch located on the maintenance panel. The On line/Off line switch should only be operated by trained service personnel and the switch must always be left in On line position after service. If the On line/Off line switch is left in On line position the printer will perform paper feed, according to the paper tape loop channel 0, when the Local Start/Stop pushbutton is activated. If the Local Start/Stop is activated while printer is in Remote condition it will have no effect.

As long as the Local operation is in progress there will be light in the Start portion of the indicator. When no local operation is in progress there will be light in the Stop portion of the indicator.

Form mode/Line mode pushbutton indicator

4.6

This pushbutton indicator is a dual indicator switch. The switch is the push-to-set, push-to-reset type.

For description of the function refer to Local Start/Stop switch (4.5).

Testprint/Paper feed pushbutton indicator

4.7

This pushbutton indicator is a dual indicator switch. The switch is the push-to-set, push-to-reset type.

For description of the function refer to Local Start/Stop switch (4.5).

Operators Control located on the relay box

4.8

A 20 ampere ac circuit breaker placed in series with the input ac is mounted on the relay box. When the breaker trips, the switch handle will travel to off position. The breaker is reset by operating the switch handle to On position.

Operators Control located on the drum gate

4.9

The operators phasing control is mounted to the right on the drum gate. Adjusting this control varies the point in time that hammer flight is initiated. This in turn varies the registration of the character as it is being printed. Bad phasing is indicated by a difference in ink density between the top and the bottom of a printed character. The top or bottom of the character may actually be missing. The phasing control should be adjusted until the tops and bottoms of the characters on each printed line are of the same density.

Operators Control, located on the paper feed assembly

4.10

Paper positioning controls (See Fig. 3)

4.10.1

The paper is horizontally positioned by two controls; the tractors provide a coarse horizontal position adjustment. Fine horizontal adjustment of ± 3 character widths are made with the horizontal paper position adjustment.

Vertical positioning of the paper is a function of four controls: the paper drive release lever, vertical paper position adjustment, dynamic vertical paper position adjustment, and the vertical paper position indicator. The paper drive release lever enables the paper to be adjusted any number of lines up or down by means of the vertical paper position adjustment when the paper drive system is stopped, and one line up or down by means of the dynamic paper position adjustment when the paper drive system is in motion. The vertical paper position indicator provides a reference for vertically aligning the paper and is used in conjunction with the vertical paper position adjust.

Paper tensioning controls (See Fig. 3)

4.10.2

The paper is tensioned by two controls: the vertical paper tension adjustment and the tractor horizontal paper tension adjustment. The vertical paper tension adjustment is used to tauten the paper between the upper and lower tractors. The two horizontal paper tension adjustments are adjusted independently, to tauten the paper between the left and right tractors.

Copies control (See Fig. 3)

4.10.3

The copies control, a three position knob, is provided to vary the distance between the drum and the hammer bank in order to accomodate various thicknesses of paper (see Fig. 3). The knob is set to 1, 3, or 6 to provide for optimum printing. The calibrations are nominal and should be tested for various part paper.

Operating Procedures required for operation of the printer

4.11

1. Application of power to the printer
2. Ribbon installation
3. Ribbon removal
4. Tape Loop preparation
5. Tape Loop installation
6. Paper loading
7. Paper tension

1. Open the front doors
2. Place the main circuit breaker located on the relay box in On position. If the neon-indicator fails to illuminate, notify service personnel.
3. Press the Power switch located on the operators control panel, and the Power indicator should illuminate. After approx. 16 seconds the power will be ok, drum on speed and the Operable indicator illuminated, presupposed paper correctly installed, drum gate closed and no time out signal present.

Removal of power to the printer

1. Press the Power switch located on the operators control panel, and the Power indicator will be extinguished.
2. Wait until the drum has stopped rotating.
3. Open front doors.
4. Place the main circuit breaker in Off position and the neon-indicator will be extinguished.

NOTE

Main circuit breaker must not be operated before the Power switch has been pressed and the drum has stopped rotating.

Ribbon Installation (see Fig. 4)

The operator should utilize the gloves supplied in the ribbon box when removing and replacing the ribbon. The printer uses standard 14 inch by 15 yards long, inked roll ribbon of high quality fabric. Perform the following procedures when installing the ribbon:

- a. Turn POWER OFF and open drum gate after character drum stops.
- b. Grasp the two ribbon spools by the left end. Insert right end of upper and lower spools into upper and lower spring-loaded hubs provided on the casting.
- c. Push the spools to the right against the spring-loaded hubs until the left ends of spools can be engaged in the two drive hubs.

- d. Align each spool so that the key on the drive hub locks into the slot in the spool.
- e. Place left and right edges of ribbon in between guides on drum gate (see Fig. 4).
- f. Close drum gate.

Ribbon Removal

4.15

Ribbon removal is the reverse of installation.

Tape Loop Preparation

4.16

The printer uses standard 8-channel business machine tape to control paper stepping. Paper, mylar or aluminum tape may be used; however, paper tape has a very short lifetime and may decrease operating reliability. Mylar or aluminum tape is therefore recommended.

Fig. 5 illustrates the relationship between the sprocketed tape and the form. Each tape drive sprocket is equivalent to one line space on the form. Thus, for a standard 11 inch form, 66 drive sprockets define one form length on the tape. When determining the next hole positions to be punched, the operator should count the line spaces from the last punched line and punch a hole in the channel location horizontal to the hole corresponding to the next line on the form.

The vertical location of the tape holes is dependent upon the particular application. The standard printer is logically mechanized to proceed to channel 0 when the LOCAL START/STOP pushbutton is operated; therefore channel 0 must be reserved for top of form. The seven remaining channels may be utilized in various ways. Fig. 5 illustrates a tape configuration where a single hole is punched for each of eight entries required for the form. Most large forms require more than eight entries. Any one channel may be used to define all the entries required for any one form. In this case, a hole is punched in that channel for each required line entry and the computer is programmed to successively enter the paper instructions for that channel. Thus each channel may be used for a specific form. Any one tape loop can then accommodate up to a maximum of seven forms. This approach results in programming simplicity since one paper instruction address is associated with each of the seven forms.

Use the following procedures to prepare a paper tape loop.

- a. Determine the required entries from the computer programmer based on the number of forms and location of entries on each form.
- b. Obtain paper instruction program for applicable form(s) from programmer.
- c. Using any manual or machine tape punch, punch a hole in tape channel 0 for the top-of-form position of the paper. (The top-of-form may be referenced to the actual top edge of the form or may be used as the initial entry.)
- d. Count the line spaces from the paper top-of-form entry to the second form entry. Punch a hole that number of sprocket holes after the top-of-form hole in the tape channel specified for the second entry.
- e. Count the number of line spaces from the top-of-form entry to the third form entry, punch a hole that number of drive holes after the top-of-form hole in the tape channel specified for the third entry.
- f. Count the line spaces for each successive form entry and punch holes in the specified tape channels.
- g. Punch a second hole in tape channel 0 at a distance from the first top-of-form hole equal to the number of lines on the form.
- h. Remove the tape from the punch.

NOTE

The tape loop should be a minimum of six inches in circumference. If form is too short, make tape loop two or three form lengths long to permit tape loop to ride freely on tape loop reader. When form is over six inches, use only one form length.

- i. Using any method recommended by the tape manufacturer, splice tape ends together with the side of the tape shown in Fig. 5 being on the outer surface of the tape loop. If possible, avoid splicing tape in area of punched holes.

Tape Loop Installation (see Fig. 6)

4.17

The tape loop is installed as follows:

- a. Operate Remote/Local pushbutton to Local.
- b. Open printer top cover. Lift tape loop reader handle until drive sprocket shoe clears drive sprocket teeth.
- c. Place the tape loop over the tape loop reader capstan and fit the tape drive holes over drive sprocket teeth with channel 0 toward the short end of the capstan.
- d. Close the tape loop reader, noting that the tape remains fitted on the drive sprocket while the drive sprocket shoe clamps it in place.
- e. Advance to top-of-form by depressing Local Start/Stop pushbutton.

NOTE

The tape should halt with the channel 0 star wheel just beyond the top-of-form hole. If the tape halts out of phase notify service personnel.

- f. After the cover is secured and the doors closed, the printer is prepared to operate if paper and ribbon are properly installed.

CAUTION

Ensure that paper and ribbon are properly loaded before operating the printer.

NOTE

With no tape loop installed, tape loop instructions will behave as if all holes are punched in all channels.

Paper Loading (See Fig. 3)

4.18

When the form being loaded is identical to the form used for the previous operation, the tractors should be properly positioned. In this case the form should be loaded onto the tractors and properly tensioned. When a new form is to be loaded, perform the following procedures:

- a. Operate Remote/Local pushbutton to Local and lift printer top cover.
- b. Ensure that tape loop is installed in reader and press Local Start/Stop pushbutton.
- c. Open drum gate and printer front doors to obtain access to the paper feed mechanism.
- d. Adjust the horizontal paper position adjustment, and the vertical paper position adjustment to the center of their range.
- e. Open ribbon mask assembly. (See Fig. 4).
- f. Open all four tractor clamps.
- g. Place paper in cabinet and insert paper up between the ribbon mask and hammer bank.
- h. Close ribbon mask and position the first print column on the form to correspond with the first print column on the hammer bank as determined by the scale on the ribbon mask and hold in that position.
- i. Slide the upper left tractor to the closest detented position to engage the tractor teeth in the form drive holes.
- j. Slide the lower left tractor over to the detented position corresponding to the upper tractor.
- k. Position the paper top-of-form entry adjacent to the top (x) on the side of the ribbon mask if the form is printed before it is advanced; or by the second (x) if the form is to be advanced before printing.
- l. Place drive holes over upper and lower left tractor teeth and close clamps.
- m. Loosen upper and lower right tractor locks, and slide tractors over to engage teeth of tractors in drive holes of form.
- n. Close clamps and lock tractors in that position.
- o. Operate the horizontal and vertical paper tension adjustment until the paper is taut between all four tractors and close drum gate.
- p. Operate the horizontal paper position adjustment to align paper with proper column using ribbon mask calibrations as a guide.
- q. Close ribbon mask and drum gate.

- r. Ensure that the paper is properly tensioned as described in paragraph 4.19.
- s. With paper and ribbon installed, program the Controller to instruct the printer to print several pages of data.
- t. While printing, adjust the horizontal and vertical paper position adjustments until the printed line is properly positioned on paper.

Paper Tension Adjustment without Paper Drive Releaser

4.19

In order to provide clear, sharp printing and minimize paper breakage, the paper must be placed under maximum vertical and horizontal tension. Adjustment of paper tension is as follows.

Horizontal Paper Tension Adjustment

4.19.1

Adjust horizontal paper tension as follows:

- a. Rotate the horizontal paper tension adjustments (see Fig. 3) to obtain as much horizontal tension as possible short of tearing or deforming the paper drive holes.

Vertical Paper Tension Adjustment

4.19.2

Adjust vertical paper tension as follows:

- a. Rotate vertical paper tension adjustment (see Fig. 3) to obtain maximum vertical tension in paper short of tearing paper drive holes.

NOTE

Some vertical deformation of the holes normally occurs when the paper is properly tensioned.

- b. Check paper for smooth taut surface between all four tractors; remove any wrinkles in paper by simultaneously adjusting appropriate horizontal and vertical paper tension adjustments.

CAUTION

Excessive tension of the paper can cause the paper to tear during printing. Slackness can cause poor vertical registration. Ensure proper tensioning before attempting operation.

When the form being loaded is identical to the form used for the previous operation, the tractors should be properly positioned. In this case, the form should be loaded onto the tractors and properly tensioned. When a new form is to be loaded, perform the following procedures:

- a. Operate Remote/Local pushbutton to Local and lift printer top cover.
- b. Ensure that tape loop is installed in reader and press Local Start/Stop pushbutton.
- c. Open drum gate and printer front doors to obtain access to the paper feed mechanism.
- d. Adjust the horizontal paper position adjustment, and the dynamic paper position adjustment to the center of their range.
- e. Open ribbon mask assembly. (see Fig. 4).
- f. Open all four tractor clamps.
- g. Place paper in cabinet and insert paper up between the ribbon mask and hammer bank.
- h. Close ribbon mask and position the first print column on the form to correspond with the first print column on the hammer bank as determined by the scale on the ribbon mask and hold in that position.
- i. Slide the upper left tractor to the closest detented position to engage the tractor teeth in the form drive holes.
- j. Slide the lower left tractor over to the detented position corresponding to the upper left tractor.
- k. Place drive holes over upper and lower left tractor teeth and close clamps.
- l. Loosen upper and lower right tractor locks, and slide tractors over to engage teeth of tractors in drive holes of form.
- m. Close clamps and lock tractors in that position.
- n. Operate the horizontal and vertical paper tension adjustments until the paper is taut between all four tractors.

- o. Set the paper drive release lever in the ADJUST position and rotate the vertical paper position adjustment until the bottom edge of the first character line to be printed is aligned with the lower edge of the ribbon mask opening.
- p. If the computer format instructs the printer to print before paper is stepped, adjust the vertical paper position indicator as follows:
 - 1. Rotate the outer ring of the vertical paper position indicator until the bottom line of position A is aligned with any one of the lines on the nylon inner ring.
 - 2. Rotate the vertical paper position adjustment knob upward until the previously selected line on the nylon inner ring lines up with the top line of position A.
- q. If the computer format instructs the printer to step paper before it is printed, operate the vertical paper position indicator as described in the above steps (p1 and p2) using position C.
- r. Reset the paper drive release lever to RUN and close drum gate.
- s. With paper and ribbon installed, program the Controller to instruct the printer to print several pages of data.
- t. While printing, adjust the horizontal and dynamic vertical paper position adjustments until the printed line is properly positioned on paper.

Paper Tension Control with Paper Drive Releaser (see Fig. 3)

4.21

In order to provide clear, sharp printing and minimize paper breakage, the paper must be placed under proper vertical and horizontal tension. Adjustment of paper tension is as follows:

- a. Turn power on.
- b. Activate the printer to advance to top-of-form.
- c. Turn power off.
- d. Open drum gate and ribbon mask.
- e. Rotate the horizontal paper tension adjustment to obtain the proper horizontal tension (see Fig. 3). Proper horizontal tension is indicated when the tractor teeth just begin to deform the outer edges of the paper holes.

- f. Rotate the vertical paper tension adjustment to obtain the maximum vertical tension (see Fig. 3). Proper vertical tension is indicated when the upper and lower tractor teeth just begin to deform the top and bottom edges of the paper holes.
- g. Check paper for a smooth, taut surface between all four tractors.

CAUTION

Slack paper can cause the paper to tear or break during printing. Slack paper will also cause poor vertical registration.

- h. Remove any wrinkles or slack by simultaneously readjusting the appropriate horizontal and vertical tension controls as required.
- i. After the cover is secured and the doors closed, the printer is now prepared to operate.

200370 IBP

110270 IBP

190869 IBP-VH 060270 LLM

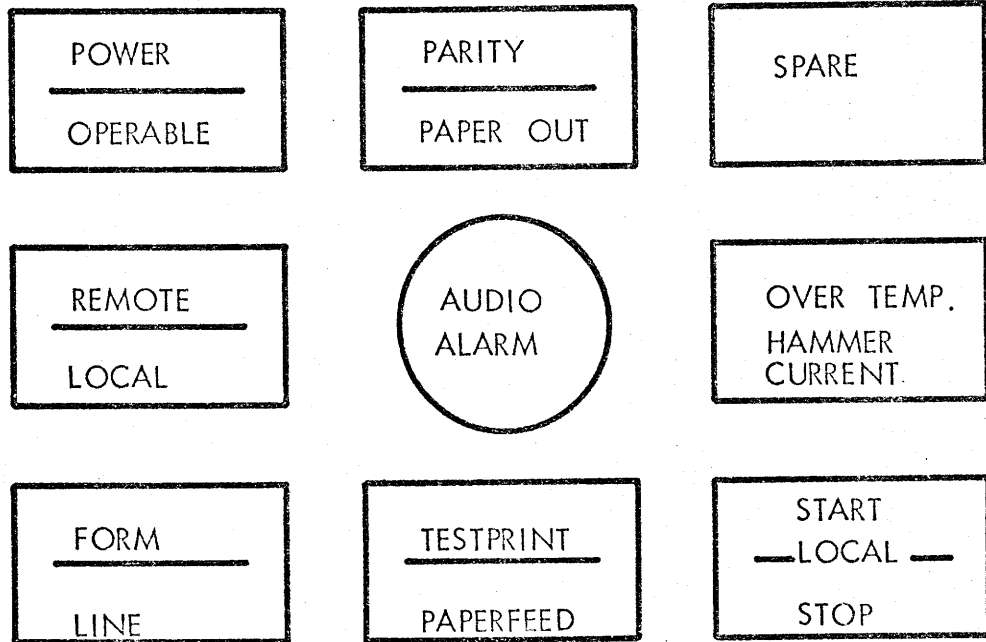

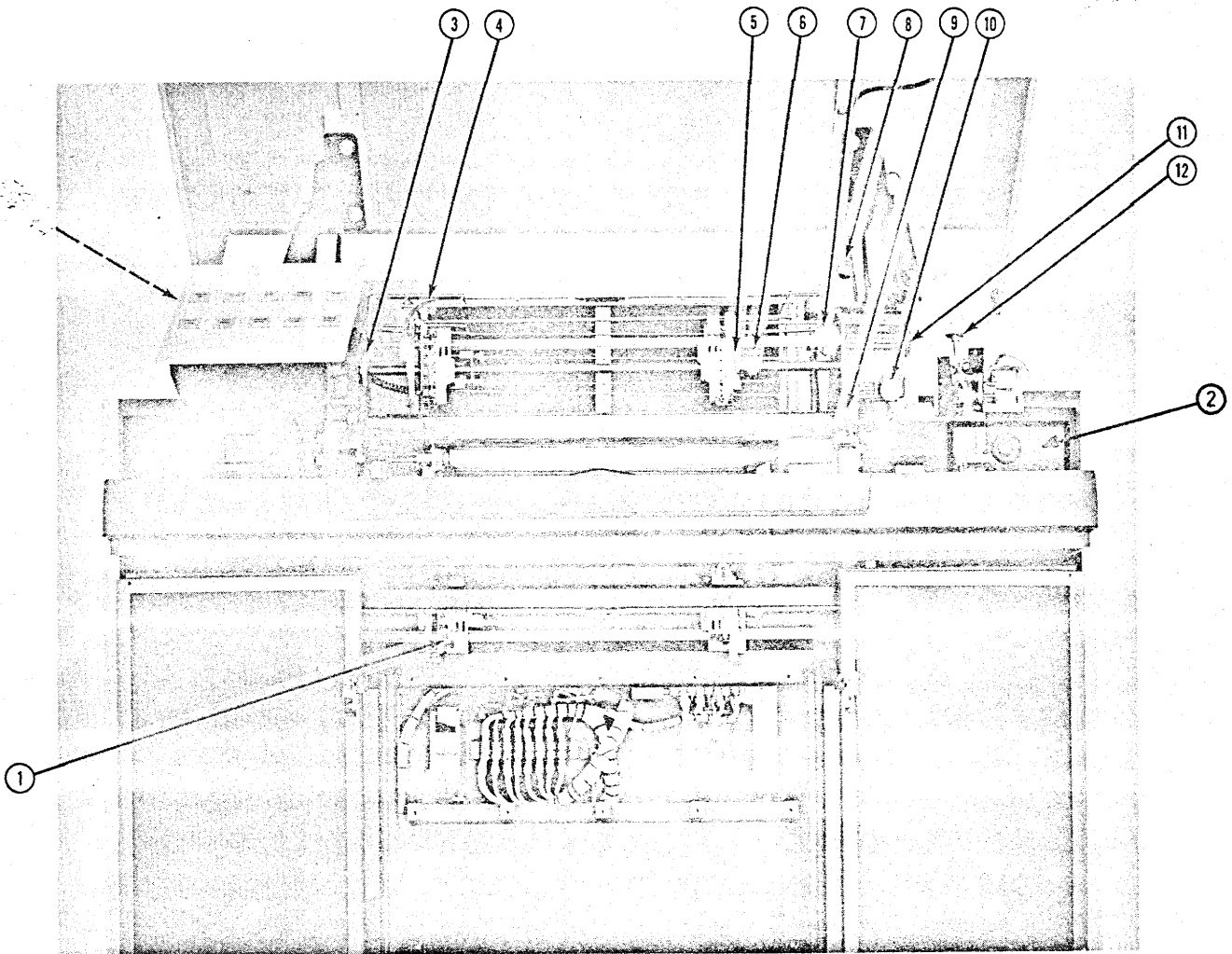

- | | |
|---|--|
| 1. TRACTOR (ONE OF FOUR) | 7. VERTICAL PAPER POSITION INDICATOR |
| 2. PHASING CONTROL | 8. PAPER DRIVE RELEASE LEVER, VERTICAL |
| 3. HORIZONTAL PAPER POSITION ADJUSTMENT | 9. COPIES CONTROL |
| 4. TRACTOR CLAMP | 10. VERTICAL PAPER TENSION ADJUSTMENT |
| 5. HORIZONTAL PAPER TENSION ADJUSTMENT | 11. VERTICAL PAPER POSITION ADJUSTMENT |
| 6. TRACTOR LOCK (ONE OF TWO) | 12. DYNAMIC VERTICAL PAPER POSITION ADJUSTMENT |

190869 IBP-VH 290170 LLM 110270 IBP 200370 IBP

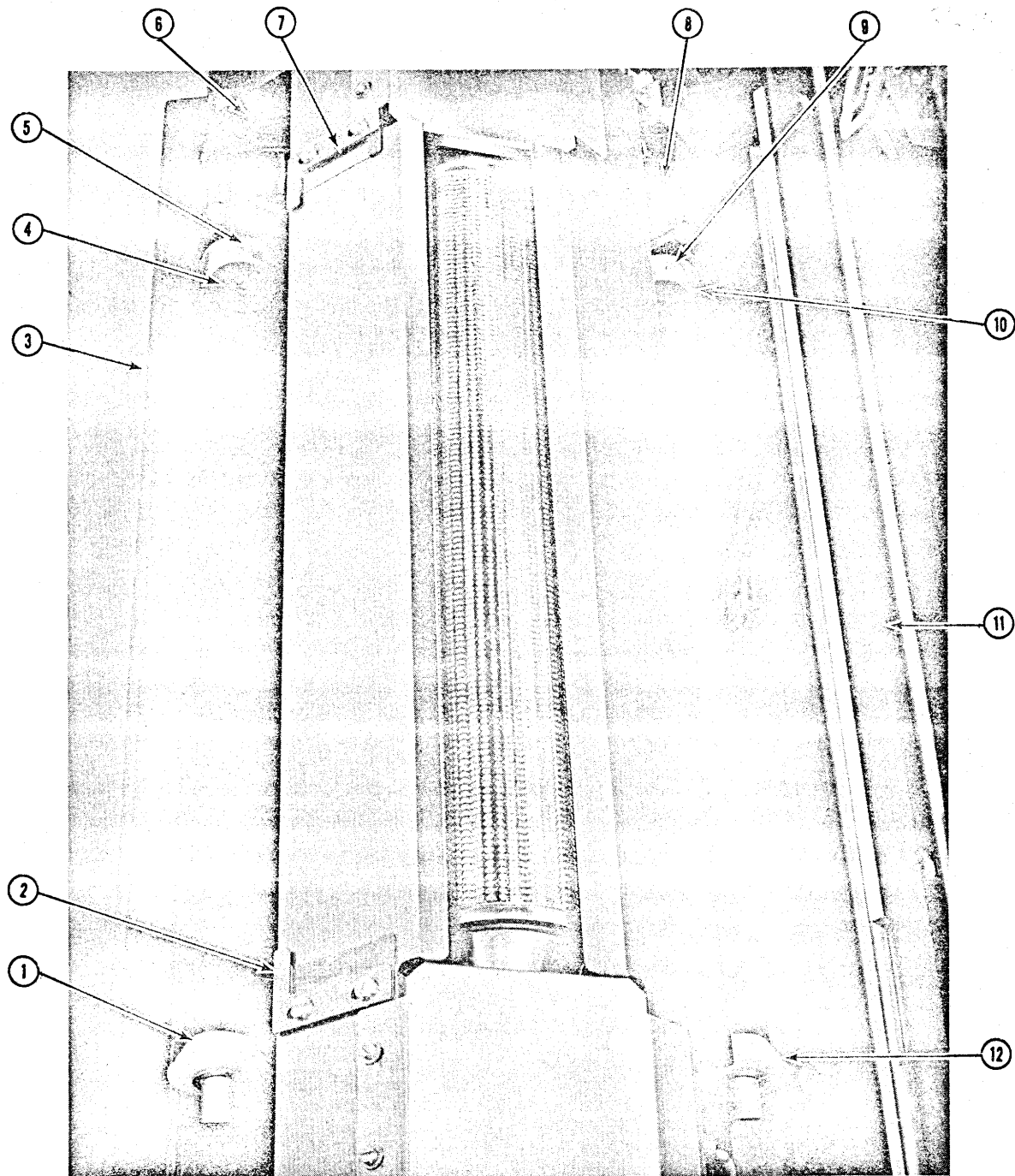

1. UPPER SPRING LOADED HUB
2. RIGHT RIBBON GUIDE
3. DRUM GATE
4. UPPER DRIVE HUB
5. UPPER SPOOL KEY
6. UPPER RIBBON MOTOR

7. LEFT RIBBON GUIDE
8. LOWER RIBBON MOTOR
9. LOWER SPOOL KEY
10. LOWER DRIVE HUB
11. RIBBON MASK ASSEMBLY
12. LOWER SPRING LOADED HUB

RIBBON INSTALLATION AND REMOVAL

Fig 4

LPE 200
A20747

Figure

200869 IBP VH 060270 LLM 110270 IBP 200370 IBP

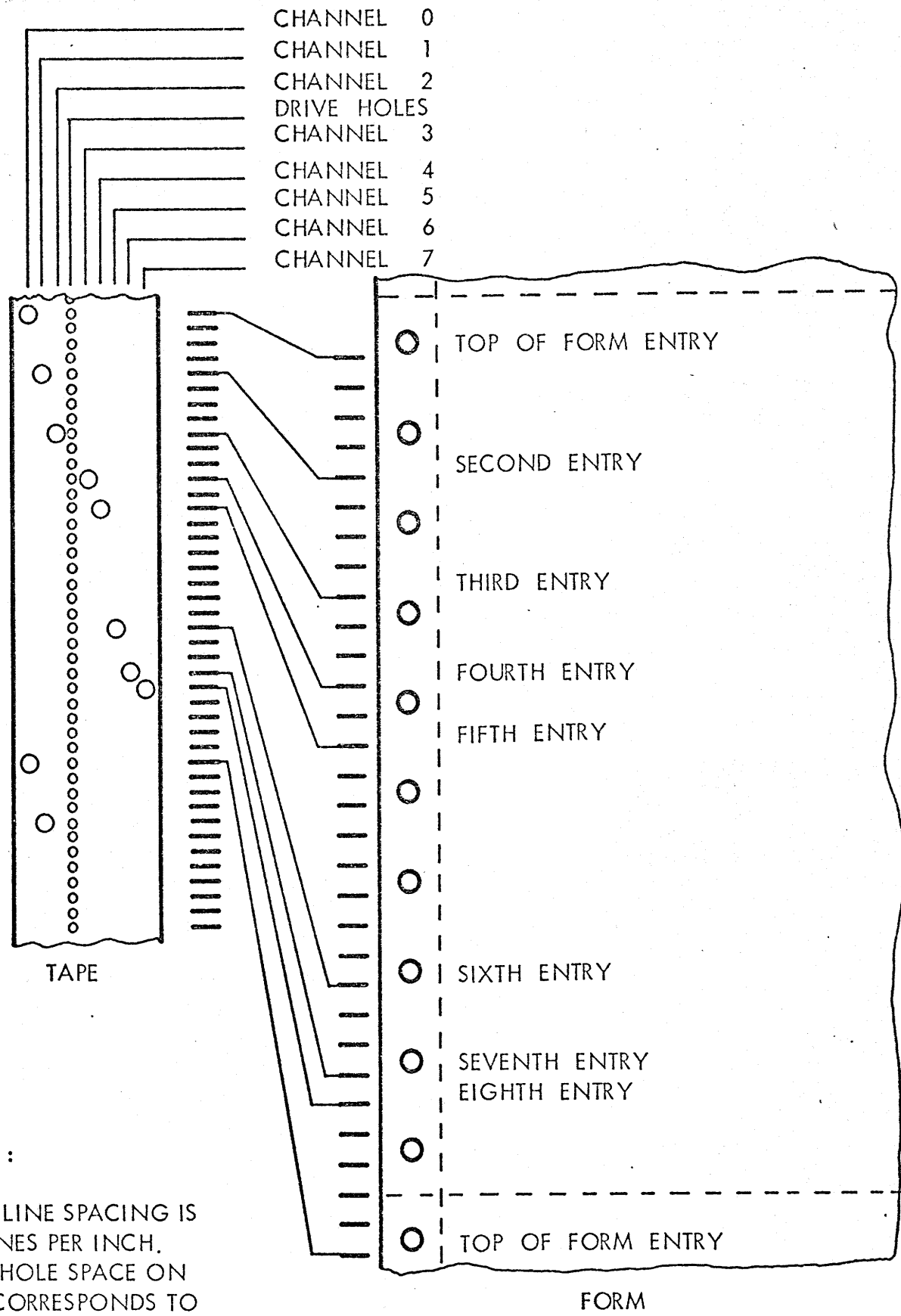

NOTE :

PAPER LINE SPACING IS SIX LINES PER INCH. EACH HOLE SPACE ON TAPE CORRESPONDS TO ONE PAPER LINE SPACE

NOTE : THERE MUST BE AT LEAST ONE ENTRY TO EACH CHANNEL

200869 IBP-VH 290170 LLM 110270 JA 200370 IBP

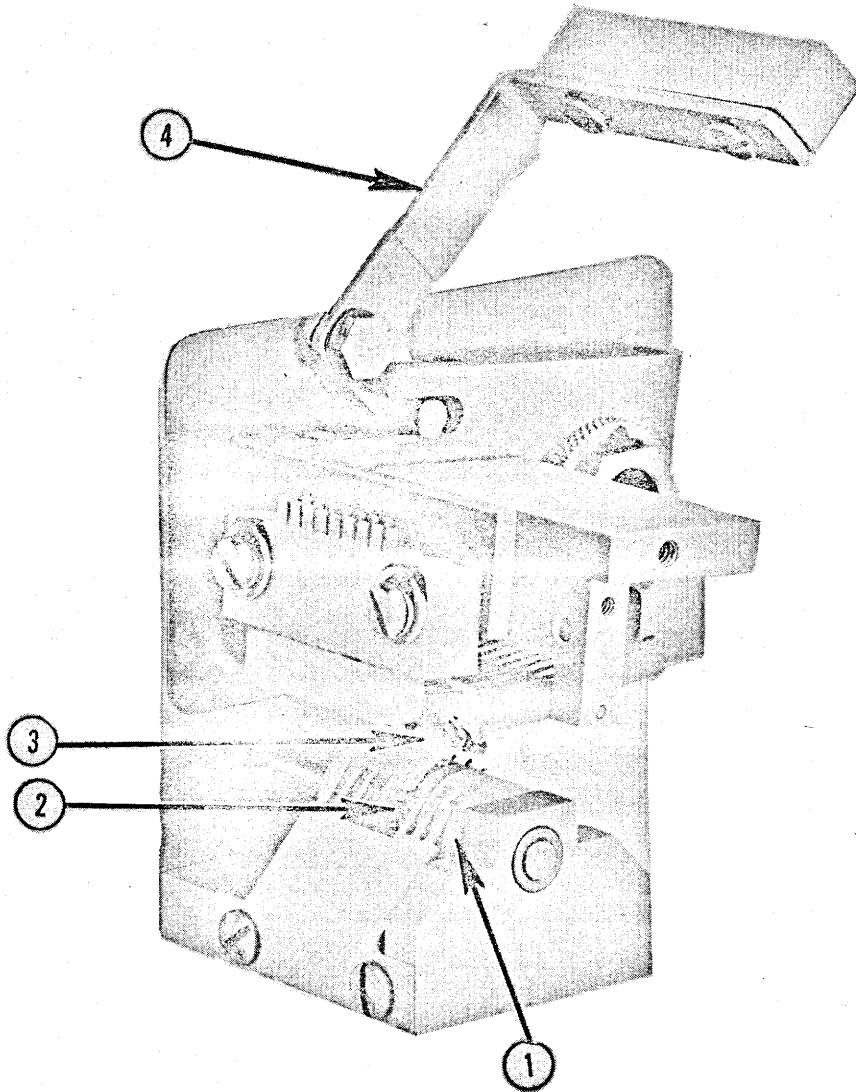

- 1. CAPSTAN
- 2. DRIVE SPROCKET

- 3. DRIVE SPROCKET SHOE
- 4. HANDLE

LPE 200

A20745

TAPE LOOP READER

Figure

Fig 6

OPTIONS

5

Optional available are

5.1

- HT Horizontal tabulation, causes moving of the print position to the next print position which is divisible by 16.
- SO Shift out, causes the printer to interpret the following character codes according to the table for shift out.
- SI Shift in, returns to standard character code assignment.
- CAN Cancel, causes reset of the line buffer, Shift in, and return of print position to first position.
- ESC Escape, is used to expand the control character set. An escape sequence for the printer must have a certain structure to be valid

ESC n NL

ESC n VT

where n is one of the characters of column 48, where only the four least significant bits are taken into account for the function. Any other structure causes the ESC character to be ignored.

ESC n NL causes printing of one line followed by a paper feed of n lines ($0 \leq n \leq 15$).

ESC n VT causes printing of one line followed by a paper feed controlled by the format tape track n.

NOTE

ESC 0 NL is equivalent to CR

ESC 0 VT is equivalent to FF.

Tables for preventive maintenance list the preventive maintenance routines and the suggested intervals for those routines. The recommended procedures have been derived empirically and necessarily reflect several assumptions. An operation criterion of a 16 hour day, five day week is used. The recommended intervals are those required to ensure maximum and consistent print quality at a high duty cycle over an extended period of time. Applications, for which qualitative demands are less stringent, may utilize a more liberal maintenance schedule. The procedures also assume a typical data processing environment. The referenced procedures for the routines will elaborate on any possible occurrences that may effect the intervals.

Cleaning

6.1

Character Drum Cleaning

6.1.1

Accumulated ink or other residue may be removed from the character drum with denatured alcohol, trichloroethylene or equivalent. It should be noted a suggested weekly interval is usually required to ensure the very best print quality. If the application allows, this interval may be extended without affecting the reliability of the equipment.

Each time the character drum is cleaned, the housing mounting the drum should be vacuumed. The operator should remove any ribbon or paper residue that may have accumulated within the housing.

Filter Cleaning

6.1.2

When the filters are dirty, use vacuum or compressed air to remove accumulated dust from metal fibers. The recommended procedure is to remove the filters from the printer and blow with clean compressed air. The filters are accessed by loosening the four quick-turn screws. Refer to 6 for preventive maintenance schedule.

Lubrication

6.2

Fig. 7 illustrates the location of the various printer mechanism lubrication points. Use oil supplied with the printer or use any of the following oils:

Gulf Harmony no. 53, Gulf Oil Company

Standard 35, Standard Oil Company of California

Caloloc Turbine Oil no. 15, Standard Oil Company of California.

CAUTION

Use oil sparingly and keep all exposed surfaces free of oil to prevent accumulation of dirt, lint or paper dust.

Ribbon Motor Lubrication

6.2.1

The ribbon drive motors should be oiled at intervals of six months. Open the drum gate and apply five drops of oil to each lubrication hole provided in the upper ribbon motor housing. Lower ribbon motor lubrication holes may be accessed with the drum gate closed by means of a pressure gun. After allowing 15 minutes to permit oil to penetrate, wipe motors clean of any oil which may bleed from holes after drum gate has been in closed position following lubrication.

Tape Loop Reader Lubrication

6.2.2

At intervals of six months, apply one or two drops of oil to each of the two oilite bearings supporting the tape loop sprocket shaft. Use pointed stick or toothpick, applying oil on shaft against end of bearing.

Tractor Shaft Lubrication

6.2.3

When the tractor(s) do not slide freely on shaft, a few drops of oil should be applied about the area that the tractors slide on the shaft. After sliding the tractors in both directions along the shaft, wipe shaft clean of any excess oil.

Additional Lubrication Points

6.2.4

The following points should also be lubricated, at six month intervals, with one or two drops of oil applied to the point of the contact area.

- a. Vertical paper position adjustment threads.
- b. Vertical paper tension adjustment threads.
- c. Horizontal paper position adjustment threads.

TABLE PREVENTIVE MAINTENANCE TIME SCHEDULE

ROUTINE	INTERVAL	REFERENCE PROCEDURE	MAINTENANCE TIME
Visually inspect paper track areas for excessive paper dust. Vacuum if required.	Daily		
Ensure that cooling blower is maintaining positive air pressure to hammer bank and paper feed assembly.	Daily		
Inspect drum for excessive ink or paper dust residue. Clean if necessary. Vacuum drum gate assembly.	Weekly or every 80 operating hours.	6.1.1	10 minutes to clean
Check tractors for mobility along splined shaft. Oil if necessary.	Weekly or every 80 operating hours.	6.2.3	2 minutes
Check vertical registration of individual characters. Adjust hammer (s) if necessary.	Weekly or every 80 operating hours.	*	10 minutes per hammer
Check tractor alignment.	Monthly or every 320 operating hours.	*	5 minutes per tractor to align
Check tractor chain tension.	Monthly or every 320 operating hours	*	5 minutes per tractor to adjust

* refer to Model dp/p-4300
 INSTRUCTION MANUAL
 MECHANICS 208716-1
 Revision D Sept. 1967

TABLE PREVENTIVE MAINTENANCE TIME SCHEDULE (CONTINUED)

ROUTINE	INTERVAL	REFERENCE PROCEDURE	MAINTENANCE TIME
Check cooling air filter mounted below the blower. Clean if required.	Bi-monthly or every 120 hours of operation	6.1.2.	5 minutes to clean
Check paper drive belt tension and wear. Adjust or replace if required.	Monthly or every 320 operating hours.	*	5 minutes to clean, 20 minutes to adjust, 45 minutes to replace
Check tractor phasing	Quarterly or every 1280 hours of operation.	*	15 minutes to adjust
Check hammer back stop screw for wear. Adjust hammer or replace back stop screw as required.	Semi-annually or every 2560 hours of operation	*	10 minutes per hammer or back stop screw
Inspect all mounting screws, bolts and nuts to ensure that they are securely fastened.	Semi-annually or every 2560 hours of operation.		30 minutes
Oil all lubrication points.	Semi-annually or every 2560 hours of operation.	6.2	10 minutes

* refer to Model dp/p - 4300
INSTRUCTION MANUAL
MECHANICS 208716-1
Revision D Sept, 1967

200869 IBP-VH 290170 LLM 110270 JA 200370 IB

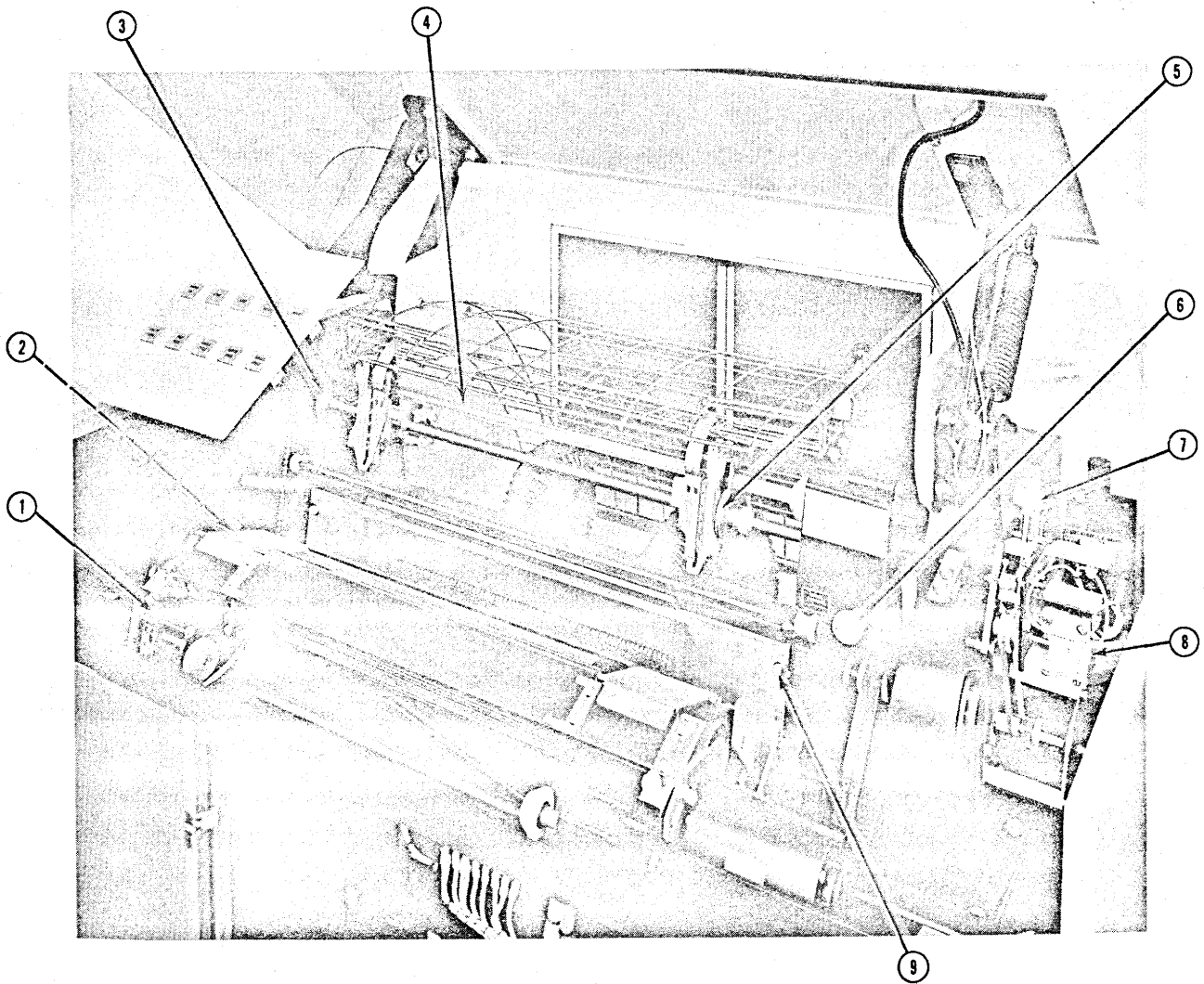

- | | |
|---|--|
| 1. Upper Ribbon Motor | 6. Vertical Paper Tension Adjustment |
| 2. Lower Ribbon Motor | 7. Vertical Paper Position Adjustment |
| 3. Horizontal Paper Position Adjustment | 8. Tape Loop Oilite Bearings |
| 4. Splined Shaft (One of Two) | 9. Note: Never Move or Loosen Ribbon Mask Socket Head Screws (2) (In Upper Cutout) |
| 5. Horizontal Paper Tension Adjustment (One of Two) | |

LPE 200

A20750

LUBRICATION POINTS

Fig 7

Figure

SPECIFICATIONS FOR CONSUMPTION GOODS

7

Paper

7.1

a) Dimensions

Standard edge punched 1/2 inch centers fanfold paper from 4,5 to 19 inches in width.

b) Types

Up to six parts, 12-pound bond (single minimum weight, 15-pound bond; or tabulating card (0.007 inch) plus a second record sheet.

Ribbon

7.2

The printer uses standard 14 inch by 15 yards long, inked roll ribbon of high quality fabric.

Tape

7.3

The printer uses standard 8-channel business machine tape to control paper stepping. Paper, Mylar or aluminum tape may be used. However paper tape has a very short lifetime and may decrease operating reliability. Mylar or aluminum tape is therefor recommended.

Cleaning

7.4

Accumulated ink or other residue may be removed from the character drum with denatured alcohol, trichloroethylene or equivalent.

Lubrication

7.5

Gulf Harmony no. 53, Gulf Oil Company

Standard 35, Standard Oil Company

Caloloc Turbine oil no. 15, Standard Oil Company.

SIGNAL SPECIFICATION

The LPE 200 is connected to the RC4000 Low Speed Data Channel.
For signal specifications refer to the description of RC4000
DATA CHANNELS. (Low speed).

This page is blank

INPUT POWER REQUIREMENTS

10

- a) Power 1.4 KW
- b) Voltage 220 VAC \pm 10 0/0
Alternative voltages are RC standard
90 - 100 - 110 - 120 - 130
200 - 210 - 220 - 230 - 240 VAC \pm 10 0/0

All voltages input are 1-phase, 3-wires
Phase
Neutral
Ground

- c) Frequency 50 Hz \pm 2 0/0

Environmental Conditions

10.1

- a) Operating
10°C (50°F) to 38°C (100°F) at
20 0/0 to 80 0/0 relative humidity.
- b) Storage
-18°C (0°F) to 52°C (125°F) at
5 0/0 to 95 0/0 relative humidity.

PHYSICAL CHARACTERISTICS

11

Dimensions	Width 119 cm (47 in)	11.1
	Depth 66 cm (26 in)	
	Height 122 cm (48 in)	
Weight	400 kg (850 lbs) app.	11.2
Installation Diagram (See Fig. 8)		11.3

220869 IBP-VH 290170 LLM 110270 JA 200370 IBF

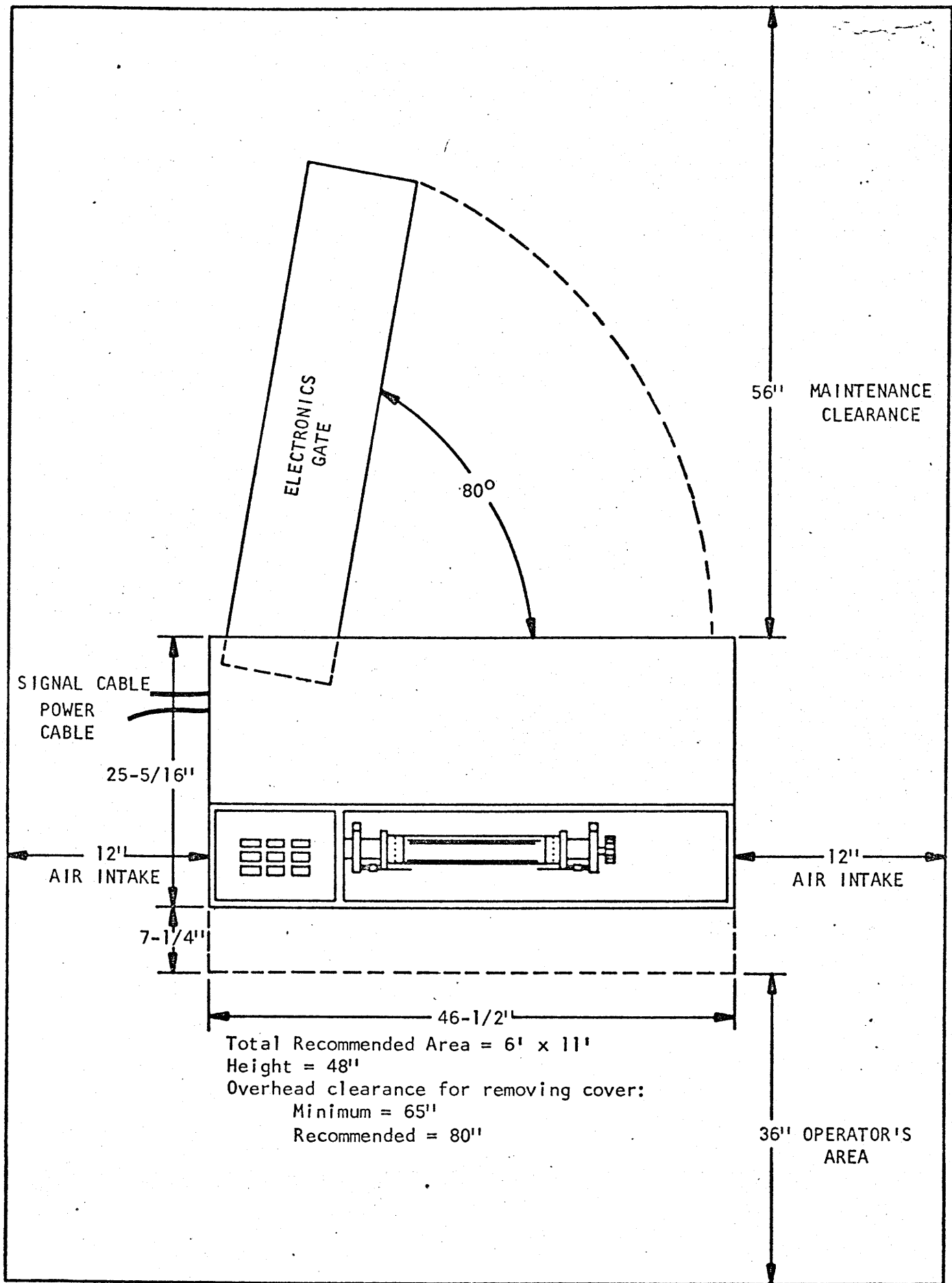

LPE 200
A20749

INSTALLATION DIAGRAM

Fig 8

Figure

This page is blank

Bus Receivers

13.1

Logic diagram 3.

For detailed information on the I/O BUS lines 17:23 refer to the RC4000 Data Channel (low speed) in section 8.

Test Information

13.2

Logic diagram 22.

The seven bit input code can be simulated from the Sim 0-6 lines.

The weight of the bits is as follows:

Sim	0	1	2	3	4	5	6
Weight	1	2	4	8	16	32	64

For further information refer to section 20 - 20.8.

Data Gates

13.3

Logic diagrams 23, 24, 25.

Data input to Reg 1 can be one of four:

1. from line 23...17
(seven bit input code)
2. from character converter 0-8
(eight bit internal code and parity)
3. from simulator 0-6
(seven bit input code)
4. from Line buffer output SR 0-7, P, M
(eight bit internal code, parity, and mark)

Register 1 and 2

13.4

Logic diagrams 23, 24, 25.

Together with Reg 2 the Reg 1 forms the 133rd column in the line buffer (132 printable columns and 1 check character column).

Reg 1 and Reg 2 are 10 bits flip-flop registers, the bits have the following weight:

REG 1, REG 2	0	1	2	3	4	5	6	7	P	M
Weight	1	2	4	8	16	32	64	128	P	M

Logic diagrams 27, 28, 29, 30

The printer accepts input characters according to the ISO 7-bit code. The graphics are internally represented by their character number on the character drum, referring to the Index pin.

As the input characters and the character numbers are not identical, the input characters are to be converted to the internal code.

The 7-bit input code can be one of four variants:

Input Code Tables available are

1. Input Code Table,
RC-Standard
for 64 char. drum, RC-standard.
2. Input Code Table,
RC-Standard incl. Options
for 64 char. drum, RC-standard
3. Input Code Table,
RC-Standard
for 96 char. drum, RC-standard
4. Input Code Table,
RC-Standard incl. Options
for 96 char. drum, RC-standard.

The column contents is interpreted

as follows :
 X = character
 YYY = int. code value
 PCB and
 Location

X	(YYY)
X	(YYY)
X	(YYY)

ROW (Input bit 3, 2, 1, 0.)

COLUMN (Input bit 6, 5, 4.)

ROW	0 (0)	1 (16)	2 (32)	3 (48)	4 (64)	5 (80)	6 (96)	7 (112)	RC
0	(255)	(255)	Space (160)	0 (4)	(255)	P (48)	(255)	P (48)	RC 0878- 1/400
1			! (28)	1 (5)	A (63)	Q (47)	A (63)	Q (47)	
2			" (30)	2 (6)	B (62)	R (46)	B (62)	R (46)	
3			(255)	3 (7)	C (61)	S (45)	C (61)	S (45)	
4			(255)	4 (8)	D (60)	T (44)	D (60)	T (44)	
5			% (25)	5 (9)	E (59)	U (43)	E (59)	U (43)	
6			& (26)	6 (10)	F (58)	V (42)	F (58)	V (42)	
7			' (29)	7 (11)	G (57)	W (41)	G (57)	W (41)	
8			((16)	8 (12)	H (56)	X (37)	H (56)	X (37)	
9	(255)) (17)	9 (13)	I (55)	Y (36)	I (55)	Y (36)	
10	NL (138)		* (27)	: (2)	J (54)	Z (35)	J (54)	Z (35)	
11	VT (139)		+ (14)	; (3)	K (53)	Æ (40)	K (53)	Æ (40)	
12	FF (140)		: (1)	< (21)	L (52)	Ø (39)	L (52)	Ø (39)	
13	CR (141)		- (15)	= (20)	M (51)	Å (38)	M (51)	Å (38)	
14	(255)		. (0)	> (22)	N (50)	(255)	N (50)	(255)	
15	(255)	(255)	/ (23)	? (31)	O (49)	- (24)	O (49)	(255)	323

Input code table
RC - standard

for
64 char. drum RC - standard

not marked positions are DEL characters (255)

The column contents is interpreted as follows:

- X = character
- YYY = int. code value PCB and Location

X	(YYY)
X	(YYY)
X	(YYY)

after SI

ROW (Input bit 3, 2, 1, 0.)

COLUMN (Input bit 6, 5, 4.)

ROW	0 (0)	1 (16)	2 (32)	3 (48)	4 (64)	5 (80)	6 (96)	7 (112)	RC
0	(255)	(255)	Space (160)	0 (4)	(255)	P (48)	(255)	P (48)	0878-1/400
1			! (28)	1 (5)	A (63)	Q (47)	A (63)	Q (47)	
2			" (30)	2 (6)	B (62)	R (46)	B (62)	R (46)	
3			(255)	3 (7)	C (61)	S (45)	C (61)	S (45)	
4			(255)	4 (8)	D (60)	T (44)	D (60)	T (44)	
5			% (25)	5 (9)	E (59)	U (43)	E (59)	U (43)	
6			& (26)	6 (10)	F (58)	V (42)	F (58)	V (42)	322
7		(255)	' (29)	7 (11)	G (57)	W (41)	G (57)	W (41)	
8	(255)	CAN (152)	((16)	8 (12)	H (56)	X (37)	H (56)	X (37)	
9	HT (137)	(255)) (17)	9 (13)	I (55)	Y (36)	I (55)	Y (36)	
10	NL (138)	(255)	* (27)	: (2)	J (54)	Z (35)	J (54)	Z (35)	
11	VT (139)	ESC (155)	+ (14)	; (3)	K (53)	Æ (40)	K (53)	Æ (40)	
12	FF (140)	(255)	, (1)	< (21)	L (52)	Ø (39)	L (52)	Ø (39)	
13	CR (141)		- (15)	= (20)	M (51)	Å (38)	M (51)	Å (38)	
14	SO (142)		. (0)	> (22)	N (50)	(255)	N (50)	(255)	323
15	SI (143)	(255)	/ (23)	? (31)	O (49)	- (24)	O (49)	(255)	

Input code table
 RC - standard incl Options
 for

64 char. drum, RC - standard

not marked positions are DEL characters (255)

The column contents is interpreted as follows:

X	(YYY)
X	
X	(YYY)

X = character
 YYY = int. code value
 PCB and Location

after SO

ROW (Input bit 3, 2, 1, 0.)

COLUMN (Input bit 6, 5, 4,)

ROW	0	1	2	3	4	5	6	7	
COLUMN	(0)	(16)	(32)	(48)	(64)	(80)	(96)	(112)	
0	(255)	(255)	Space (160)	0 (4)	(255)	(255)	(255)	(255)	RC 0878-1/402
1			Ä (34)	1 (5)					
2			Ö (33)	2 (6)					
3			Ü (32)	3 (7)					
4			(255)	4 (8)					
5			Æ (18)	5 (9)					
6			(255)	6 (10)					324
7			Æ (40)	7 (11)					
8	(255)	CAN (152)	Ø (39)	8 (12)					
9	HT (137)	(255)	À (38)	9 (13)					
10	NL (138)	(255)	Ä (34)	10 (19)					
11	VT (139)	ESC (155)	Ö (33)	(255)					
12	FF (140)	(255)	Ü (32)						
13	CR (141)		Æ (40)						
14	SO (142)		Ø (39)						
15	SI (143)	(255)	À (38)	(255)	(255)	(255)	(255)	(255)	RC 0878-1/403 325

not marked positions are DEL characters (255)

Input code table
 RC - standard incl. Options
 for
 64 char. drum, RC - standard

The column is interpreted as follows:

X = character
 YYY = int. code value
 PCB and Location

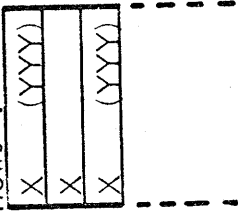

ROW (Input bit 3, 2, 1, 0.)
 COLUMN (Input bit 6, 5, 4, 3)

ROW	0	1	2	3	4	5	6	7	RC
COLUMN	(0)	(16)	(32)	(48)	(64)	(80)	(96)	(112)	
0	(255)	(255)	Space (160)	0 (4)	(255)	P (48)	(255)	P (80)	RC 0878-1/404
1	(255)	(255)	! (28)	1 (5)	A (63)	Q (47)	(255)	q (79)	
2	(255)	(255)	" (30)	2 (6)	B (62)	R (46)	(94)	r (78)	
3	(255)	(255)	(255)	3 (7)	C (61)	S (45)	(93)	s (77)	
4	(255)	(255)	(255)	4 (8)	D (60)	T (44)	(92)	t (76)	
5	(255)	(255)	% (25)	5 (9)	E (59)	U (43)	(91)	u (75)	322
6	(255)	(255)	& (26)	6 (10)	F (58)	V (42)	(90)	v (74)	
7	(255)	(255)	' (29)	7 (11)	G (57)	W (41)	(89)	w (73)	
8	(255)	(255)	((16)	8 (12)	H (56)	X (37)	(88)	x (69)	
9	(255)	(255)) (17)	9 (13)	I (55)	Y (36)	(87)	y (68)	
10	NL (138)	(255)	* (27)	: (2)	J (54)	Z (35)	(86)	z (67)	
11	VT (139)	(255)	+ (14)	; (3)	K (53)	Æ (40)	(85)	æ (72)	
12	FF (140)	(255)	, (1)	< (21)	L (52)	Ø (39)	(84)	ø (71)	
13	CR (141)	(255)	- (15)	= (20)	M (51)	À (38)	(83)	à (70)	
14	(255)	(255)	: (0)	> (22)	N (50)	(255)	(82)	(255)	
15	(255)	(255)	/ (23)	? (31)	O (49)	(24)	(81)	(255)	

not marked positions are DEL characters (255)

The column is interpreted as follows:

X	(YYY)
X	
X	(YYY)
---	---
---	---
---	---

X = character
 YYY = int. code value
 PCB and Location

after SI

ROW (Input bit 3, 2, 1, 0.)

COLUMN (Input bit 6, 5, 4.)

ROW	0	1	2	3	4	5	6	7	RC
	(0)	(16)	(32)	(48)	(64)	(80)	(96)	(112)	
0	(255)	(255)	Space (160)	0 (4)		P (48)		p (80)	RC 0878-1/404
1			! (28)	1 (5)	A (63)	Q (47)	a (95)	q (79)	
2			" (30)	2 (6)	B (62)	R (46)	b (94)	r (78)	
3			(255)	3 (7)	C (61)	S (45)	c (93)	s (77)	
4			(255)	4 (8)	D (60)	T (44)	d (92)	t (76)	
5			% (25)	5 (9)	E (59)	U (43)	e (91)	u (75)	
6			& (26)	6 (10)	F (58)	V (42)	f (90)	v (74)	
7		(255)	' (29)	7 (11)	G (57)	W (41)	g (89)	w (73)	322
8	(255)	CAN (152)	((16)	8 (12)	H (56)	X (37)	h (88)	x (69)	
9	HT (137)	(255)) (17)	9 (13)	I (55)	Y (36)	i (87)	y (68)	
10	NL (138)	(255)	* (27)	: (2)	J (54)	Z (35)	j (86)	z (67)	
11	VT (139)	ESC (155)	+ (14)	; (3)	K (53)	Æ (40)	k (85)	æ (72)	
12	FF (140)	(255)	' (1)	< (21)	L (52)	Ø (39)	l (84)	ø (71)	
13	CR (141)	(255)	- (15)	= (20)	M (51)	À (38)	m (83)	à (70)	
14	SO (142)	(255)	. (0)	> (22)	N (50)	(255)	n (82)	(255)	
15	SI (143)	(255)	/ (23)	? (31)	O (49)	- (24)	o (81)	(255)	RC 0878-1/405 323

not marked positions are DEL characters (255)

The column is interpreted as follows:

X	(YYY)
X	
X	(YYY)

X = character
 YYY = int. code value
 PCB and Location

after SO

ROW (Input bit 3, 2, 1, 0.)

COLUMN (Input bit 6, 5, 4.)

ROW	0 (0)	1 (16)	2 (32)	3 (48)	4 (64)	5 (80)	6 (96)	7 (112)	
0 (255)			Space (160)	0 (4)					RC 0878-1/402
1			À (34)	1 (5)					
2			Ö (33)	2 (6)					
3			Ü (32)	3 (7)					
4			(255)	4 (8)					
5			Ɔ (18)	5 (9)					
6			(255)	6 (10)					324
7			Æ (40)	7 (11)					
8	(255)	CAN (152)	Ø (39)	8 (12)					RC 0878-1/406
9	HT (137)		À (38)	9 (13)					
10	NL (138)		ä (66)	10 (19)					
11	VT (139)	ESC (155)	ö (65)	(255)					
12	FF (140)		ü (64)						
13	CR (141)		æ (72)						
14	SO (142)		φ (71)						
15	SI (143)		ø (70)						325

not marked positions are DEL characters (255)

Character converting system.

The seven bit input character is loaded into the seven least significant bits of Reg 1, where the bits have the following weight:

REG 1	0	1	2	3	4	5	6	7	P	M
	1	2	4	8	16	32	64	128	P	M

The input character value determines the address in the Read Only Store where the internal character code is loaded (fixed wired). The Read Only Store is a 9-bit 128 (optional 256) words store. After conversion the internal character code is loaded into the nine least significant bits of Reg 1.

Line Buffer

13.6

Logic diagram 31.

The line buffer is a 12-bit 132 columns Shift register for storing one line.

The Shift register bits have the following weight:

SR-	0	1	2	3	4	5	6	7	P	M	ECO	EC1
	1	2	4	8	16	32	64	128	P	M	ECO	EC1

- SR-(0-6) = 128 graphic characters.
- SR-7 = control character indication.
- SR-P = parity (odd parity in SR-(0-7, P, M)).
- SR-M = mark, indicates that the character has been printed.
- SR-ECO
- SR-EC1 = two bits for storing numbers of ECHOes detected.

The Line buffer and Reg 1, Reg 2 are coupled to work as a 133 columns cyclic shift register, i.e. 132 graphic characters and the check character.

Parity Check

13.7

Logic diagram 57.

The information stored in REG 1-(0-7, P, M) is checked for odd parity in two (optional three) levels.

PF inp. (optional)

During load of input characters the parity is checked. If a parity error is detected the input character is deleted.

PF con.

After conversion to internal code the parity is checked. If a parity error is detected, the input character is deleted.

PF memory

During the total print period the characters loaded into the line buffer is checked for odd parity. If a parity error is detected in a character the character will be marked, i.e. the character is not to be printed. If the parity error is detected after the character has been printed, the character will be marked too.

Check of Check Character

13.8

Logic diagram 58.

Before each new shift period during the total print period the information loaded in REG 2-(0-7, P, M) should be the check character, if not, the check error is detected to indicate that something is wrong in connection with the shift sequence.

The check character has the following code

REG 2 bit	0	1	2	3	4	5	6	7	P	M
	0	0	0	0	0	0	0	1	1	1

Mark Logic

13.9

Logic diagram 42.

All columns in the line buffer have a mark bit position. The mark bit indicates if the character stored in the column has been printed. During load of the line all mark bits are cancelled except for the check character.

When coincidence is found in a column, i.e. the character is to be printed, the mark bit is added and the parity bit is inverted.

If a parity error is detected during print, the column is marked so that the character will not be printed later on.

During Reload, i.e. loading the line just printed, mark bits will be cancelled, except for the check character and the parity bit will be inverted.

Column Counter and Decoding

13.10

Logic diagrams 37, 38, 39.

The column counter is an eight bit resetable counter, where counting can be inhibited. The column counter bits have the following weight:

CC bit	0	1	2	3	4	5	6	7
	1	2	4	8	16	32	64	128

The column counter bits are decoded in two groups.

- one for 16-X-decoding lines and
- one for 16-Y-decoding lines.

The decoding lines are used for addressing the 132 hammer drivers and for some control functions.

Index and Char. Strobe

13.11

Logic diagrams 43, 44, 45.

The character drum is equipped with an Index pin determining the beginning of the character drum, a Character Count wheel, determining the beginning of a new character, and two pick-ups for generating index pulse respectively character pulses.

The pick-up pulses are amplified and fed into the Index and Character Strobe logic (logic diagrams 44, 45).

Character Strobe phasing adjustment can be done at two levels,

1. Operators Phase Adjustment
2. Technicians Phase Adjustment.

Maximum adjustment for each of the two adjustments will be no more than half the total variation.

Character Counter

13.12

Logic diagram 46.

The character counter is a 7-bit resetable counter.

The character counter bits have the following weight:

Char. count	0	1	2	3	4	5	6
	1	2	4	8	16	32	64

The CHAR STR advances the Character Counter by one.

As the Index determines the reset point, the contents of the counter will always be the character number referring to the Index.

Character drums available are

1. 64 char. drum, RC-standard
2. 96 char. drum, RC-standard

64 char. drum, RC-standard.

D-P art work:

A/W 213440 4300.

FONT TYPE

Except for the 10 (basis of ten) character, all characters are OCR-B FONT TYPE.

The (underline) character is located on the baseline.

CHARACTER
NO

FONT TYPE

0	.	OCR - B	period
1	,	↑	comma
2	:	↑	colon
3	;	↑	semicolon
4	0	↑	zero
5	1	↑	one
6	2	↑	two
7	3	↑	three
8	4	↑	four
9	5	↑	five
10	6	↑	six
11	7	↑	seven
12	8	↑	eight
13	9	↑	nine
14	+	↑	plus
15	-	↑	minus
16	(↑	open parenthesis
17)	↓	closed parenthesis
18	⌘	OCR - B	currency sign
19	10	↑	basis of ten
20	=	OCR - B	equal
21	<	↑	less than
22	>	↑	great than
23	/	↑	slash
24	—	↑	under line
25	%	↑	percent
26	&	↑	ampersand
27	*	↑	asterisk
28	!	↑	exclamation
29	'	↑	apostrophe
30	"	↑	quotation mark
31	?	↓	question

CHARACTER
NO

FONT TYPE

32
33
34
35
36
37
38
39
40
41
42
43
44
45
46
47
48
49
50
51
52
53
54
55
56
57
58
59
60
61
62
63

Ü
Ö
Ä
Z
Y
X
Å
Ø
Æ
W
V
U
T
S
R
Q
P
O
N
M
L
K
J
I
H
G
F
E
D
C
B
A

OCR - B

CAPITAL LETTER

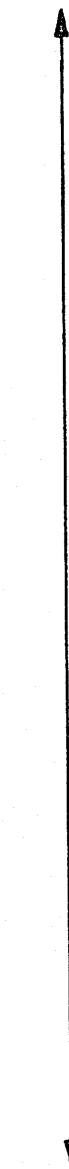

OCR - B

CAPITAL LETTER

64 CHARACTERS DRUM

96 char. drum, RC-standard.

D-P art work:

A/W 213520 4300.

FONT TYPE

Except for the 10 (basis of ten) character, all characters are OCR-B FONT TYPE.

The _ (underline) character is located on the baseline.

CHARACTER
NO

FONT TYPE

0	.	OCR - B	period
1	,	↑	comma
2	:	↑	colon
3	;	↑	semicolon
4	0	↑	zero
5	1	↑	one
6	2	↑	two
7	3	↑	three
8	4	↑	four
9	5	↑	five
10	6	↑	six
11	7	↑	seven
12	8	↑	eight
13	9	↑	nine
14	+	↑	plus
15	-	↑	minus
16	(↓	open parenthesis
17)	↓	closed parenthesis
18	⌘	OCR - B	currency sign
19	¹⁰	↑	basis of ten
20	=	OCR - B	equal
21	<	↑	less than
22	>	↑	great than
23	/	↑	slash
24	—	↑	under line
25	%	↑	percent
26	&	↑	ampersand
27	*	↑	asterisk
28	!	↑	exclamation
29	'	↑	apostrophe
30	"	↑	quotation mark
31	?	↓	question

96 CHARACTERS DRUM

CHARACTER
NO

FONT TYPE

32
33
34
35
36
37
38
39
40
41
42
43
44
45
46
47
48
49
50
51
52
53
54
55
56
57
58
59
60
61
62
63

Ü
Ö
Ä
Z
Y
X
Å
Ø
Æ
W
V
U
T
S
R
Q
P
O
N
M
L
K
J
I
H
G
F
E
D
C
B
A

OCR - B

CAPITAL LETTER



OCR - B

CAPITAL LETTER

96 CHARACTERS DRUM

CHARACTER
NO

FONT TYPE

64	ü
65	ö
66	ä
67	z
68	y
69	x
70	å
71	ø
72	æ
73	w
74	v
75	u
76	t
77	s
78	r
79	q
80	p
81	o
82	n
83	m
84	l
85	k
86	i
87	h
88	g
89	f
90	e
91	d
92	c
93	b
94	a
95	

OCR - B

SMALL LETTER

OCR - B

SMALL LETTER

96 CHARACTERS DRUM

Comparator

13.13

Logic diagrams 47, 48.

During Print the character counter (CHAR COUNT' 0-6) is compared with Line buffer output, SR (0-6), to indicate that printing of the Line buffer character is wanted. However, the coincidence will be inhibited if the Line buffer character is marked or a control character is loaded.

If printing of the character is wanted the COINCIDENCE FF is set to enable the hammer strobe circuits.

Hammer Strobe Generator

13.14

Logic diagram 48.

If no inhibit situation exists the hammer strobe is generated by timing pulse T3.

Note that no hammer strobe is generated if Drum gate is open or Parity error in the Line buffer character or Paper Out.

Hammer Drivers

13.15

Logic diagrams 65, 66, 67, 68.

132 hammer drivers are used, one for each print position on the character drum.

If a hammer driver is selected by the CCX-decoding and CCY-decoding lines and a hammer strobe is present at the input, it means that the hammer is to be activated. When fired the hammer driver will generate an ECHO signal any time the driver is selected, every 940 uSec.

Normally the hammer driver will be fired for app. 1.8 mSec.

The hammer drivers generate an output signal HAMMER CURRENT SENSING to indicate how long time the Hammer drivers are on.

This signal is supervised for lasting less than 400 mSec. In case of error detecting the power to hammers and paper feed system will be released.

Paper Feed and Hammer Power Supply

13.16

Figure 9.

The hammer power supply supplies the hammer drivers, and the hammer bank with +50V DC for driving the hammers. The paper feed power supply supplies the paper feed power amplifier with +35V, -35VDC for driving the paper feed motor.

Refer to

MODEL dp/p-4300

INSTRUCTION MANUAL

MECHANICS

208716-1

REVISION D

SEPT 1967.

NOTE, in the LPE 200 the hammers are numbered 0, 1, 2, 3
129, 130, 131.

Print Control Logic

13.18

Logic diagrams 40, 41, 64.

When, during load of the line, the full-line signal is detected and a print instruction has been loaded, speed check is started to secure that the char. drum is on speed before printing is initiated. If no drum speed error exists the print period will be started at the next character strobe. For detailed information refer to: General Information (Functional Description, section 1). The print period is terminated when all the printable characters have been printed, i.e. all columns with printable characters must include the SR-M bit, and not printable columns must include the SR-7 bit. The logic circuit for storage printed is shown on logic diagram 41.

Termination of the print period will start the Enable Echo Check period (wait for last possible echoes).

Speed

13.19

Logic diagram 58.

The char. drum speed is supervised for correct rotational time. As the character speed, 1070 char./sec = 940 uS/char., is the same for all sizes of character drums the 940 uS/char. is supervised for correct duration. The duration is supervised to be within the following limits:

$$883,2 \text{ uS} < \text{Time/char.} < 985,6 \text{ uSec.}$$

The lower and upper limits are defined by the column counter, values 138 respectively 154.

In case of error the SPEED FF will be set.

Echo

13.20

Logic diagram 62, 63, 64.

During the ECHO CHECK period all columns in the Line buffer are checked for correct ECHO, i.e.

printable columns must have 1 or 2 echoes

not printable columns must have 0 echoes.

See logic diagram 64.

Refer to 13.15 (Hammer Drivers) for generation of ECHO signals. Detection of echoes takes place during the print and enable echo check periods. The detection circuits are shown on logic diagram 62.

The echoes detected in a column are stored in the EC(0-1) bits in the Line buffer, i.e. any column in the Line buffer after printing will hold the following information:

SR 0 1 2 3 4 5 6 7 P M ECO EC1

where

SR 0-6 are the character bits.

SR 7 is 0 for printable characters and 1 for not printable character.

SR P is the parity bit.

SR M is 0 for not printed columns and 1 for printed columns.

SR EC(0-1) is the numbers of echoes detected in the column.

On logic diagram 63 the echo counter REG 1-EC(0-1) is shown together with REG 2-EC(0-1).

Data SR-EC(0-1), stored number of echoes, can be transferred to the echo counter REG 1-EC(0-1). The echo counter is advanced by one if an echo is detected, and after this the new number of echoes in the column is stored together with the column information.

Counting in echo counter is inhibited if the REG 1-EC(0-1) = 1,1.

Paper Out and Drum Gate Open

13.21

Logic diagram 60.

Paper Feed Control Logic

13.22

Logic diagrams 49, 50.

Loading of parameters for the following paper motion is done during the paper feed signal.

1. preset PCR and CNT
2. transfer to PCR and TPE/CNT
3. generate paper advance signal.

The circuits are shown on logic diagram 49.

The logic for start and stop of paper motion is shown on logic diagram 50 and so is the logic for the HI/LO velocity flip flop. The paper can be fed at two velocities. HI = 35 inch/sec and LO = 20 inch/sec.

The last line in a paper feed motion is always executed at the low velocity.

As the stop time for the paper is app. 5 mS the paper moving signal is needed to secure that no printing can be started until the paper is fully stopped. The logic for paper moving is shown on logic diagram 49.

Paper Control Register

13.23

Logic diagram 51.

In PCR(0-3) the parameter for the following paper motion is loaded.

If tape mode is selected the PCR will hold the number of the selected tape loop channel. Only the three least significant bits are taken into consideration. If count mode is selected, the PCR will hold the number of lines to be stepped, (max. 15 lines).

During the count mode the PCR(0-3) is decreased by one for each line strobe detected.

Normally the parameters loaded will be

instruction	mode	parameter
CR	CNT=1	PCR=0
NL	CNT=1	PCR=1
FF	TPE=1	PCR=0
VT	TPE=1	PCR=1

If the ESC option is used the following parameters may be added to the above-mentioned.

instruction	mode	parameter
ESC n NL	CNT=i	PCR=n
ESC n VT	TPE=i	PCR=n

Tape Loop Register

13-12

Logic diagrams 53, 54, 55.

Tape loop register is an 8 bits register, one bit for each channel on the tape loop. The tape loop register will always hold the information from the position on the tape loop just sensed. On logic diagrams 54, 55 the logic for selecting a hole in the specified channel is shown too.

Strobe Generator

13.25

Logic diagrams 43, 44.

The paper feed drive assembly is equipped with a count wheel for line strobe and a pick-up. The pick-up signal is amplified and fed into the LSA and LSB logic on logic diagram 44.

LSA (line strobe A) is the transfer pulse which transfers tape loop information to the Tape Loop register.

LSB (line strobe B) is used in the paper control logic. e.g. timing pulse for Run/Stop, HI/LO, and count pulse for PCR during count mode.

Paper Feed Servo and Power Amplifier

13.26

Logic diagram 52.

The Servo amp. input START determines the velocity wanted at the paper feed motion. From this START signal the Servo amp. generates a velocity ramp curve, which is compared with the DC tachometer reflected voltage. The difference between the ramp and the reflected voltage controls the servo output to the paper feed power amplifier.

The paper feed power amplifier controls the forward reverse current to the paper feed drive motion.

The Servo amplifier output can be inhibited by the brake paper feed signal.

Time Out

13.27

Logic diagram 59.

The time out signal includes:

1. Print cycle i.e. a print period has lasted more than app. 10 sec.
2. Echo too long i.e. one or more echoes have lasted more than app. 3 mS.
3. Speed i.e. the char. drum is not on speed.
4. Paper feed too long i.e. the paper motion has lasted more than app. 10 sec., or the output to paper feed motor has been positive for more than app. 10 sec., or output to paper feed motor has been too negative for more than app. 10 sec.

Bus Receivers

13.28

Logic diagram 1.

For detailed information of the four I/O lines refer to the RC4000 low speed data channel. Section 8 in General information.

DEV. Connected and DEV. Ready

13.29

Logic diagram 6.

The Dev. connected signal indicates that all voltages are switched on and o.k.

The Dev. ready signal indicates that the printer is ready to accept input.

Bus Receivers

13.30

Logic diagram 2.

For detailed information on the I/O BUS lines 10-16 refer to the RC4000 low speed data channel. Section 8 in General information.

Command and Address Decoding

13.31

Logic diagrams 4, 5.

The only valid commands to the printer are Write and Sense commands. Only the basic command field is taken into consideration.

The Write and Sense commands are stored in the write and sense command flip flops respectively, for use during the data phase of the I/O operation.

The printer has a fixed wired Dev. number. When this number is present at the input lines 10-17 during the selection phase, the Dev. address decoding indicates that the line printer is addressed. The Sel B signal indicates that an I/O operation is in progress.

Interrupt and Status Logic

13.32

Logic diagram 7.

During remote operation the printer generates an interrupt signal which indicates that the stored line has been printed and the paper motion has been started.

During Sense operation the printer status information is gated to the I/O BUS lines 0-5, via line transmitters. For detailed information refer to sections 3 and 4 in General information.

Clock and Timing

13.33

Logic diagrams 16, 17.

Clock Circuits

The clock generator is a 5 MHz free running square wave generator. By means of a count flip flop, a 2,5 MHz square wave pulse is derived from the 5 MHz clock pulse.

Timing Circuits

Mainly the timing circuits are designed to generate a sequence of four discrete timing pulses (T1-T4) for use in the printer logic. The timing circuits also generate a clock pulse (PB-CP) specially used in connection with the push-button logic.

For detailed information see Timing diagram TC7.

Basic Control Logic

13.34

Logic diagrams 18, 19, 20, 21.

The Basic Control logic can be started either from input or from character drum. On logic diagram 19 the selection is illustrated. During the Enable Timing F. Char. Str. period the control logic is started from the Char. drum. Otherwise it is started from input. Any new start of the control logic is synchronized by means of the SNT (1, 2, and 3) circuits, which resynchronizes the clock and timing circuits.

The synchronizing circuits are illustrated on logic diagram 20. On logic diagram 18 the logic for generating of transfer pulses is shown.

On logic diagram 21 the circuits for generating first char. of new line, Set check character, Char. to load and the End of Load function are shown. For further information refer to List of names.

Control Character Decoding

13.35

Logic diagrams 32, 33, 34, 35, 36.

All control characters are internally represented by their input value plus the 128 bit. The decoding of the 32 control positions is shown on logic diagram 32.

The Delete decoding, also shown on logic diagram 32, is a full decoding of 8 bits.

The NSC logic is shown on logic diagram 33, for further information refer to List of names.

The SO/SI FF on logic diagram 33 indicates if the following characters are to be found either in the Shift out or in the Shift in part of the input code table. Normally the printer only will be equipped with the Shift in part of the input code table. Refer to section 5.1.

On logic diagram 34 the logic circuits for HT and ESC are illustrated. HT and ESC functions are optional, refer to section 5.1.

The logic circuits for the four paper instructions are illustrated on logic diagrams 35 and 36.

During character load the paper instruction flip flops are controlled from the control character decoding lines.

During Auto load the paper instruction flip flops are controlled from the Form mode, Line mode.

n-Logic and n-Reg.

13.36

Logic diagrams 18, 26.

The ESC n (NL, VT) function (optional) is described in section 5.1. Before conversion the four least significant bits of the input character are transferred to the n-Reg. The weight of the bits are:

n-Reg. bit	0	1	2	3
	1	2	4	8

The contents of the n-Reg. is used as parameter for the following paper feed instruction.

The correct structure of the ESC n (NL, VT) function is supervised on logic diagram 18. the n-FF indicates if structure is correct.

Pushbutton Logic

13.37

Logic diagrams 9, 10, 11, 12, 13.

The logic circuits for Local/Remote and Local Start/Stop switches are illustrated on logic diagrams 9 and 10.

Any time the Local/Remote switch is activated the Remote FF2 will generate one pulse, duration 6,4 uS.

Any time the Local Start/Stop switch is activated the St/St FF2 will generate one pulse, duration 6,4 uS.

The Remote flip flop indicates if the line printer is either in the Remote state or in the Local state. For further information refer to section 4.3.

Stop indicates if:

- a. it is wanted to shift from Remote to Local or
- b. it is wanted to stop the running testprint.

End indicates if:

- a. shifting from Remote to Local can be performed or
- b. terminating of the running testprint can be performed.

Testprint indicates that a testprint operation is in progress.

Paper feed Local indicates that a paper operation is in progress.

Testprint and Paper feed Local are controlled from the operators control panel and the maintenance panel (refer to section 20, OFF line operating).

Operators Control Indicators

13.38

Logic diagrams 14, 15.

The Remote/Local indicators are described in details in section 4.3.

The LOCAL Start/Stop indicators are described in section 4.5. Refer to section 4.6 and 4.7 for the Form mode/Line mode resp. Testprint/Paper feed description.

External Indicator

13.39

Logic diagram 8.

The RC4000 Operator Control panel two indicator lamps are located one for the Remote state and one for the Local state.

The control and driver circuits are illustrated on logic diagram 8.

Indicator Logic

13.40

Logic diagram 61.

For detailed information of Operable indicator, Paper out indicator, and Parity indicator refer to sections 4.2 and 4.4.

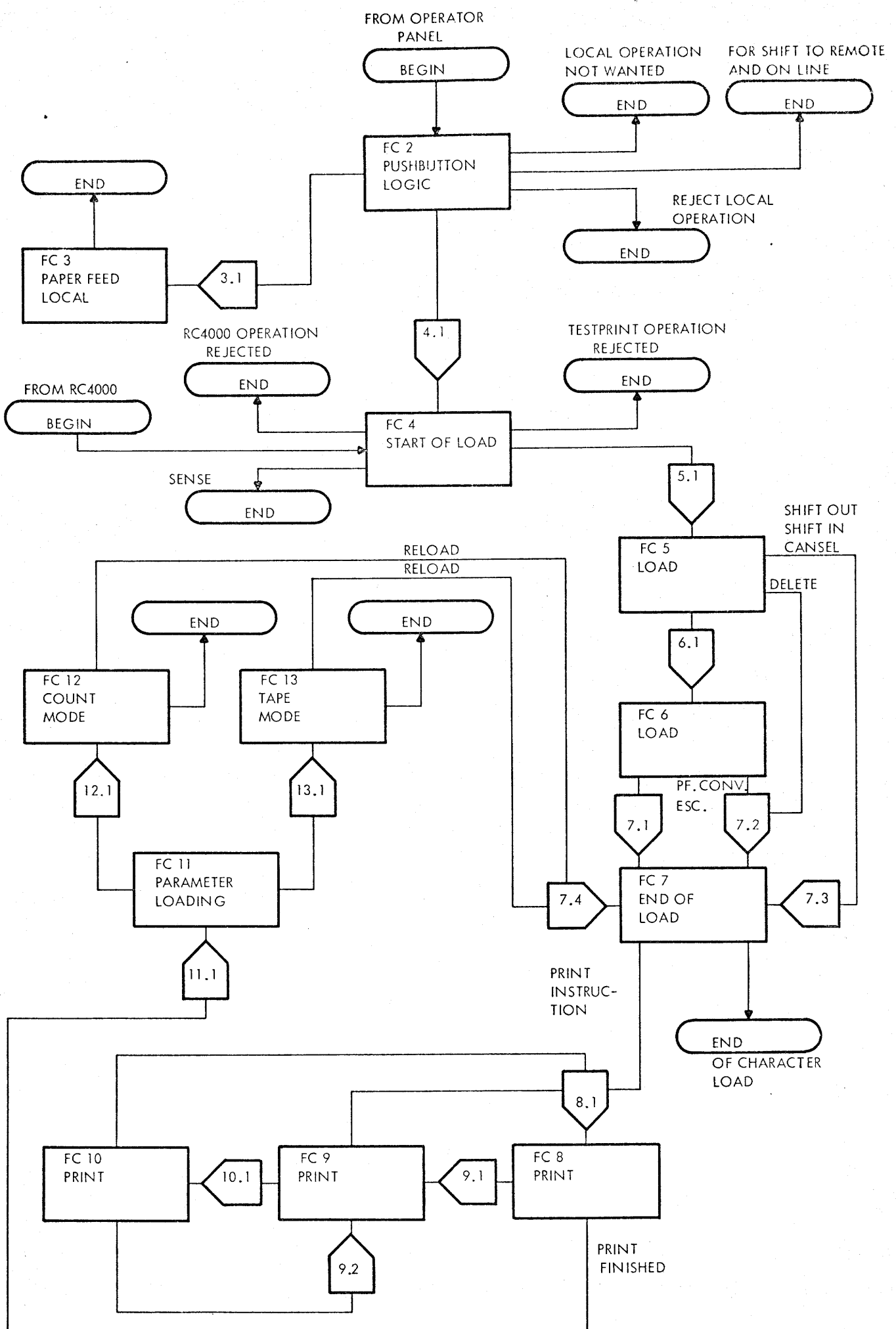

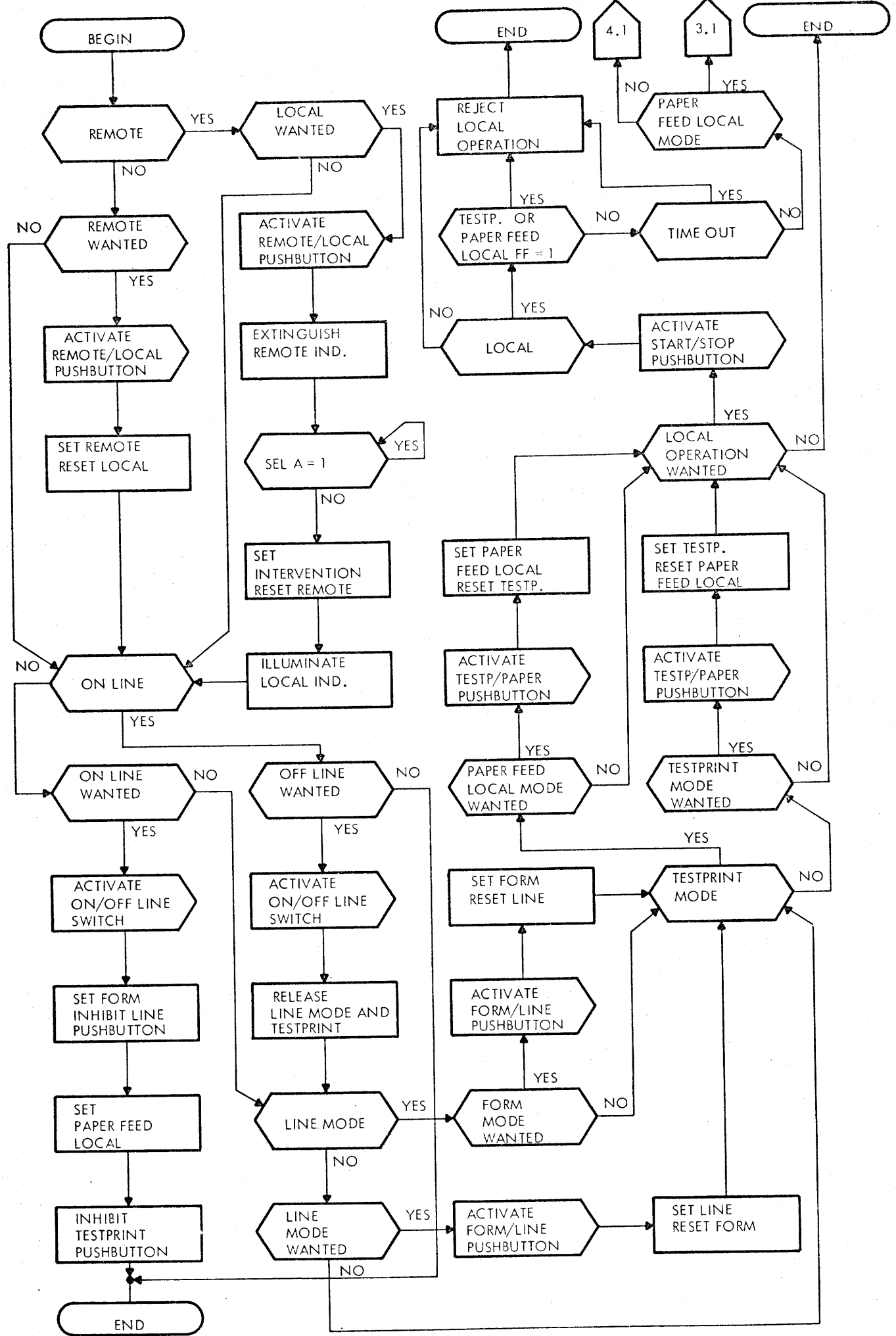

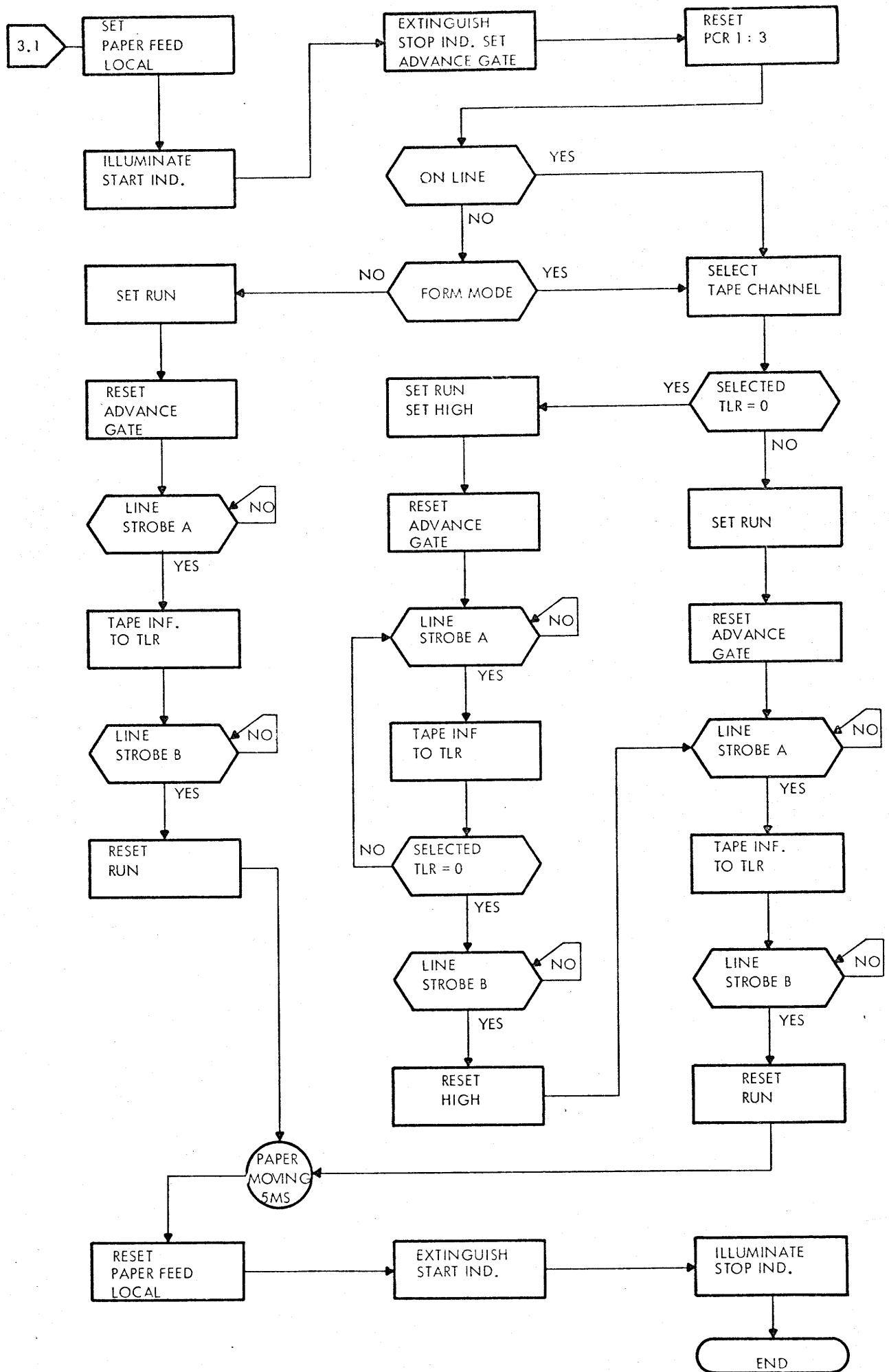

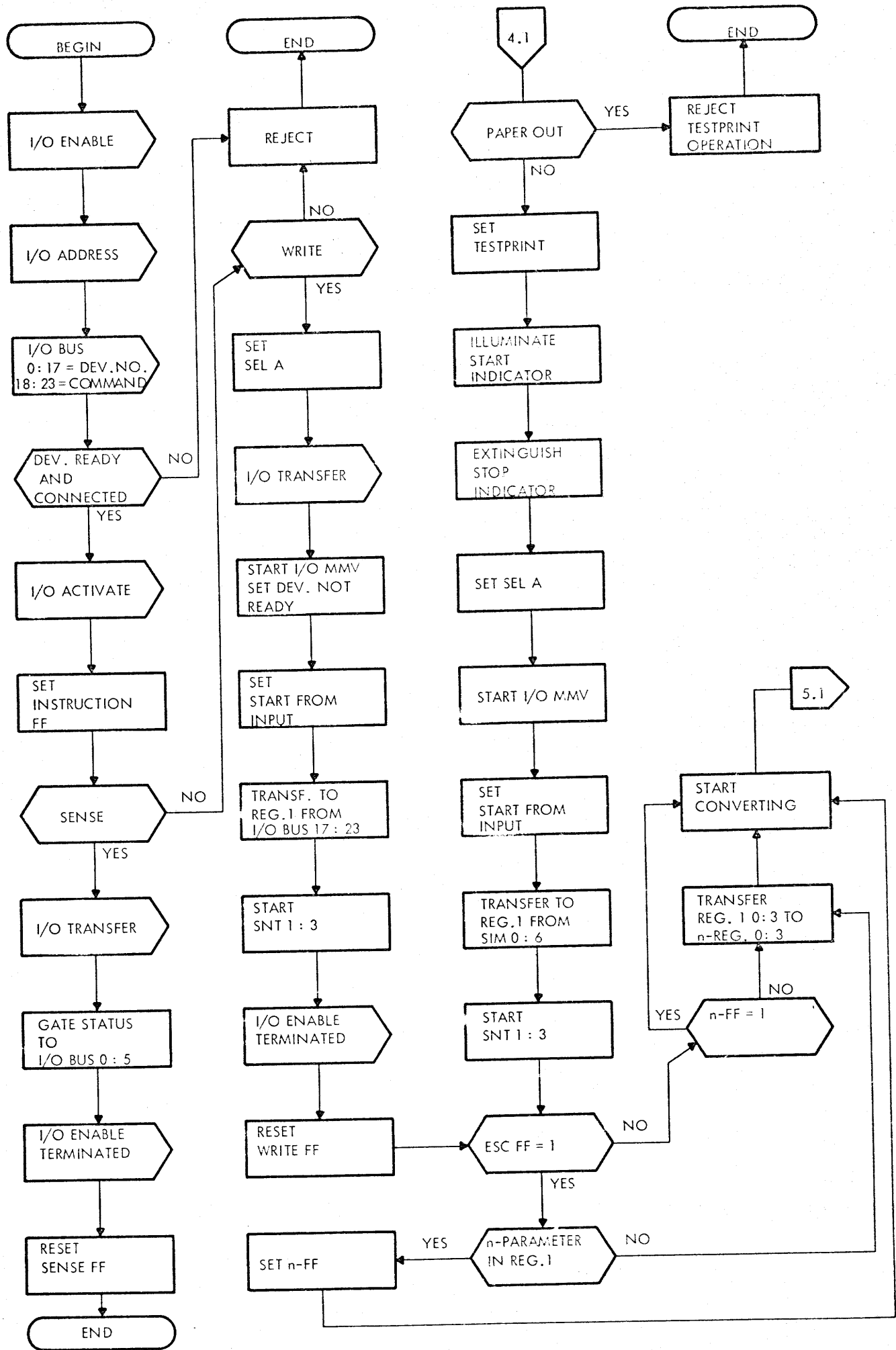

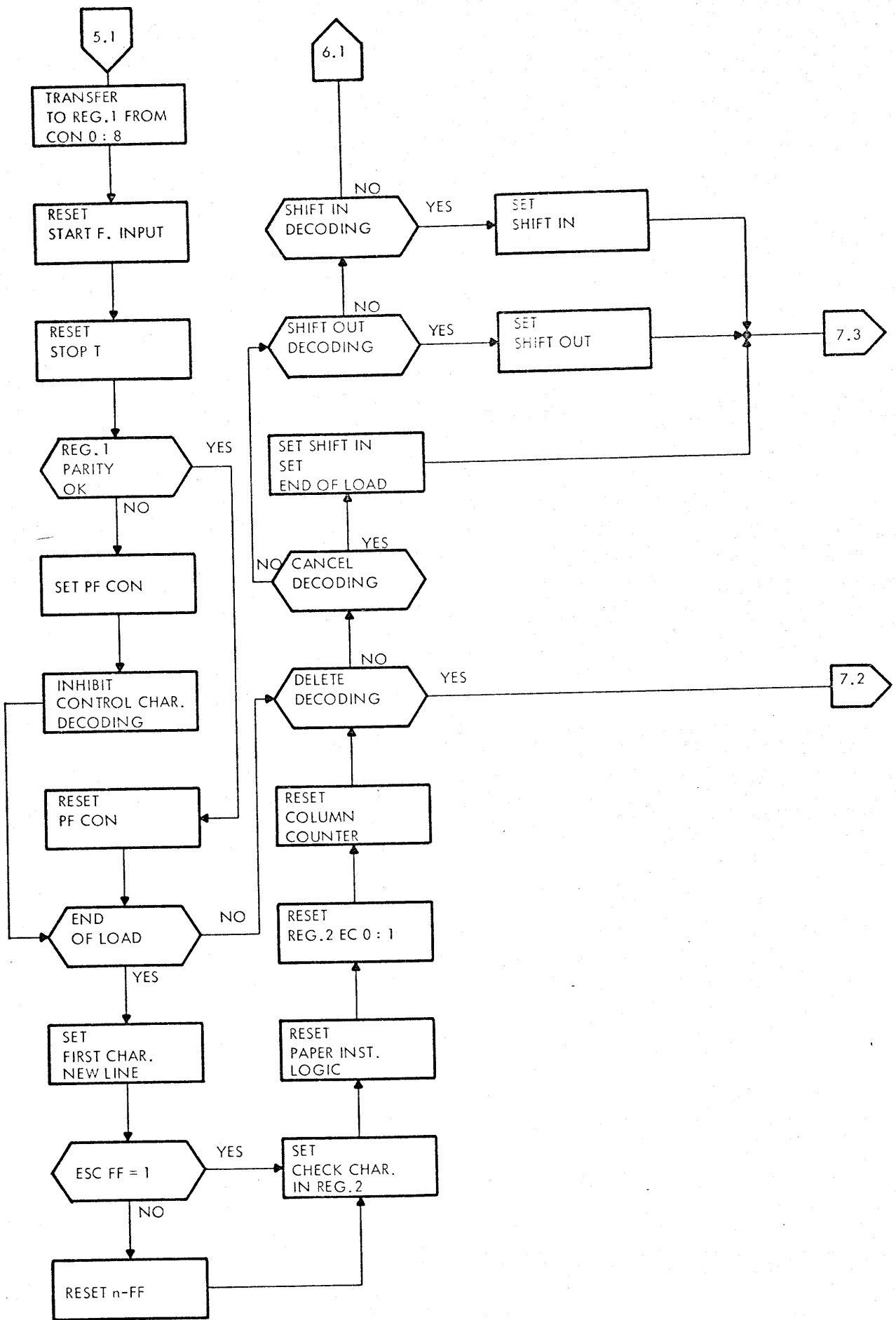

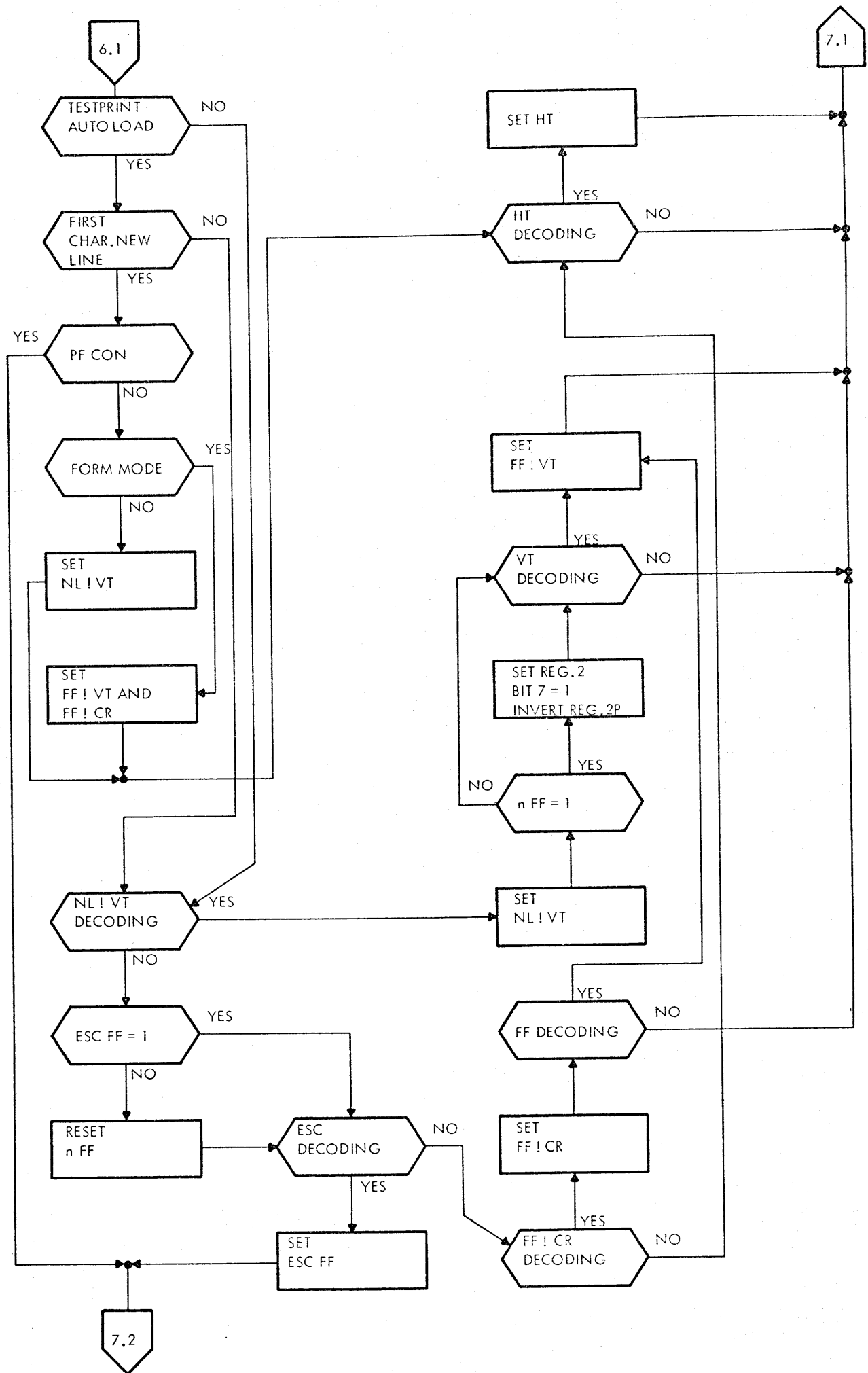

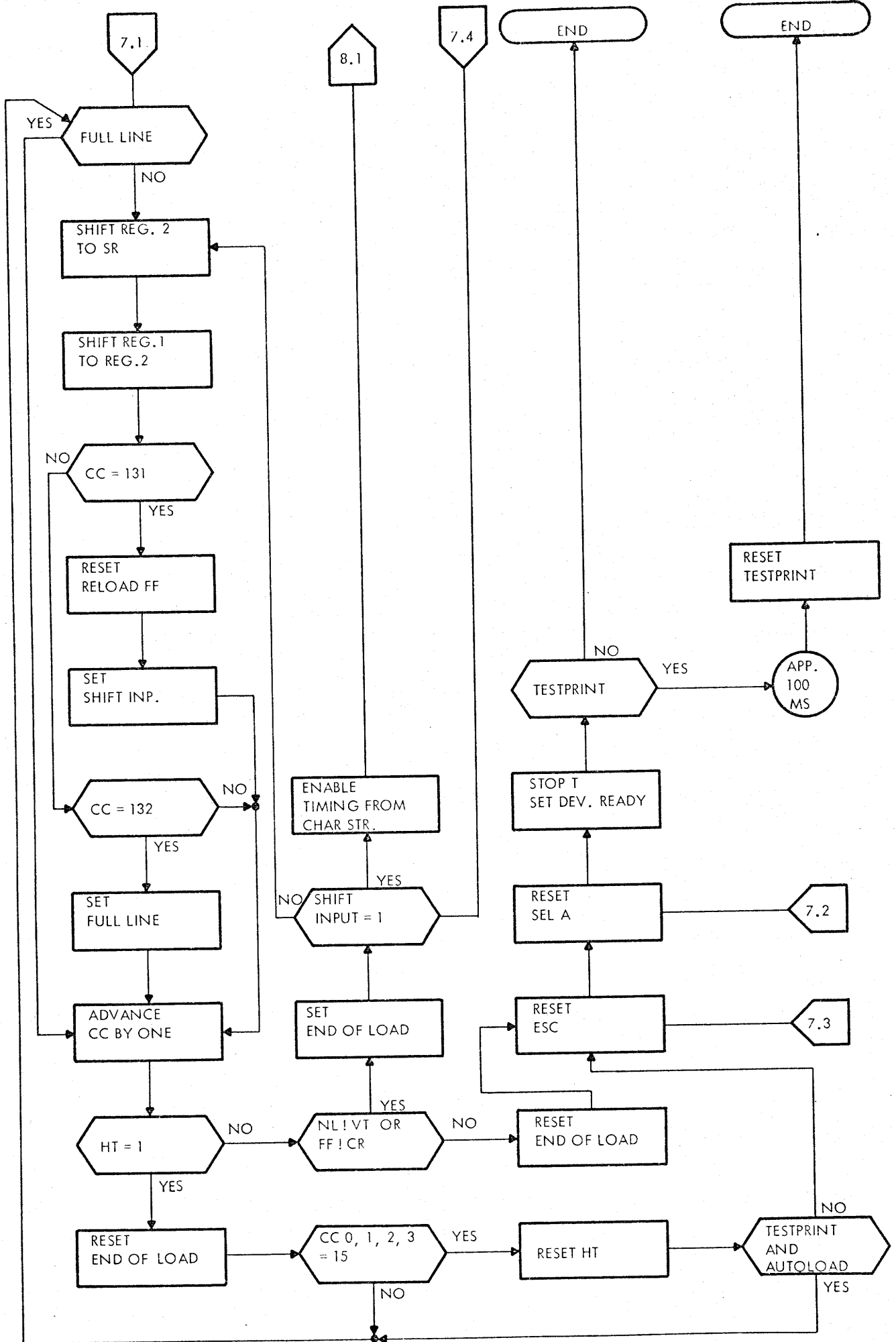

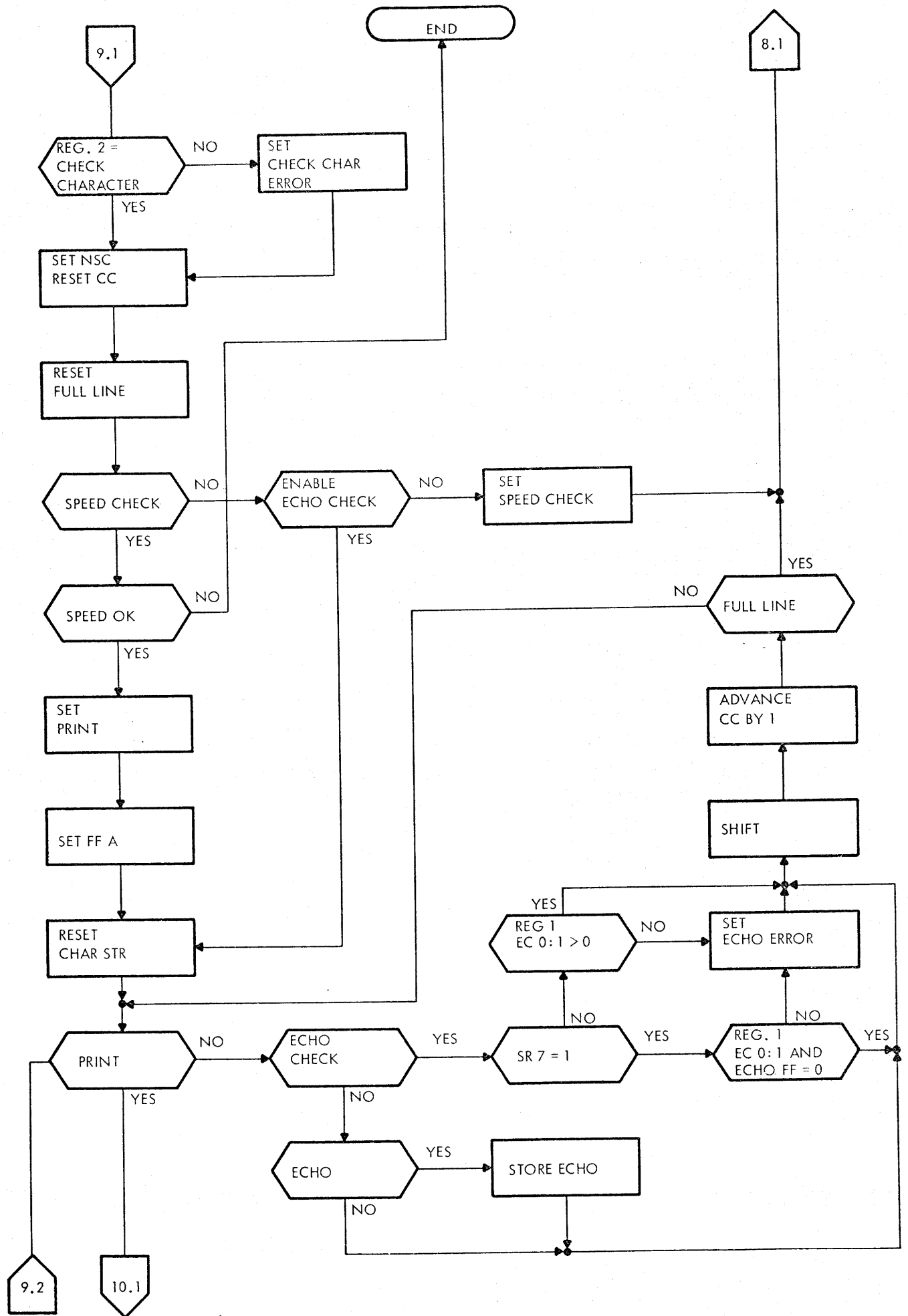

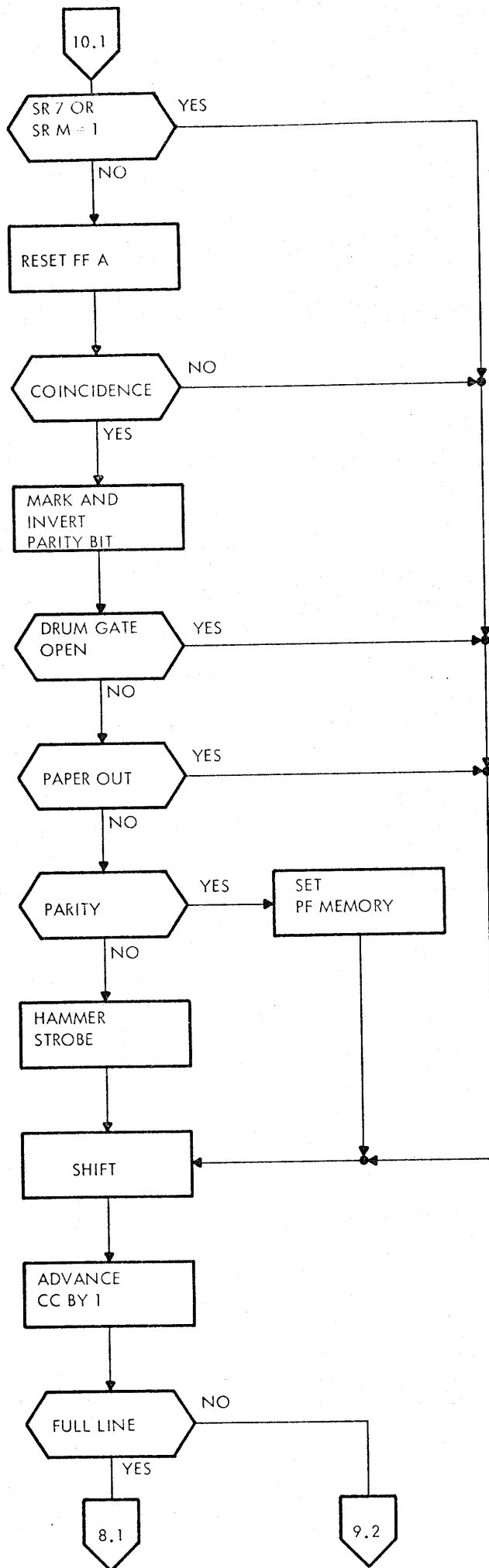

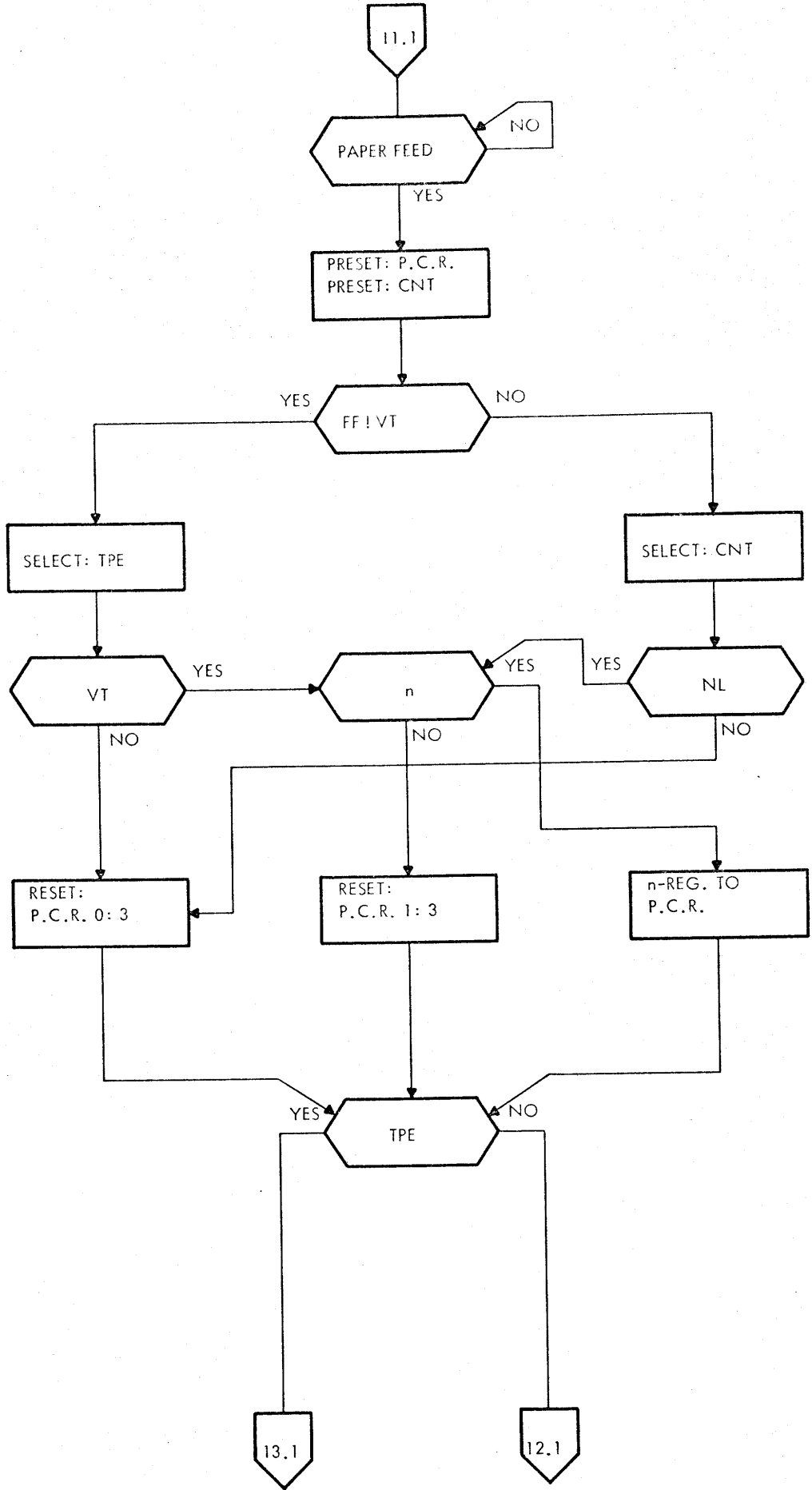

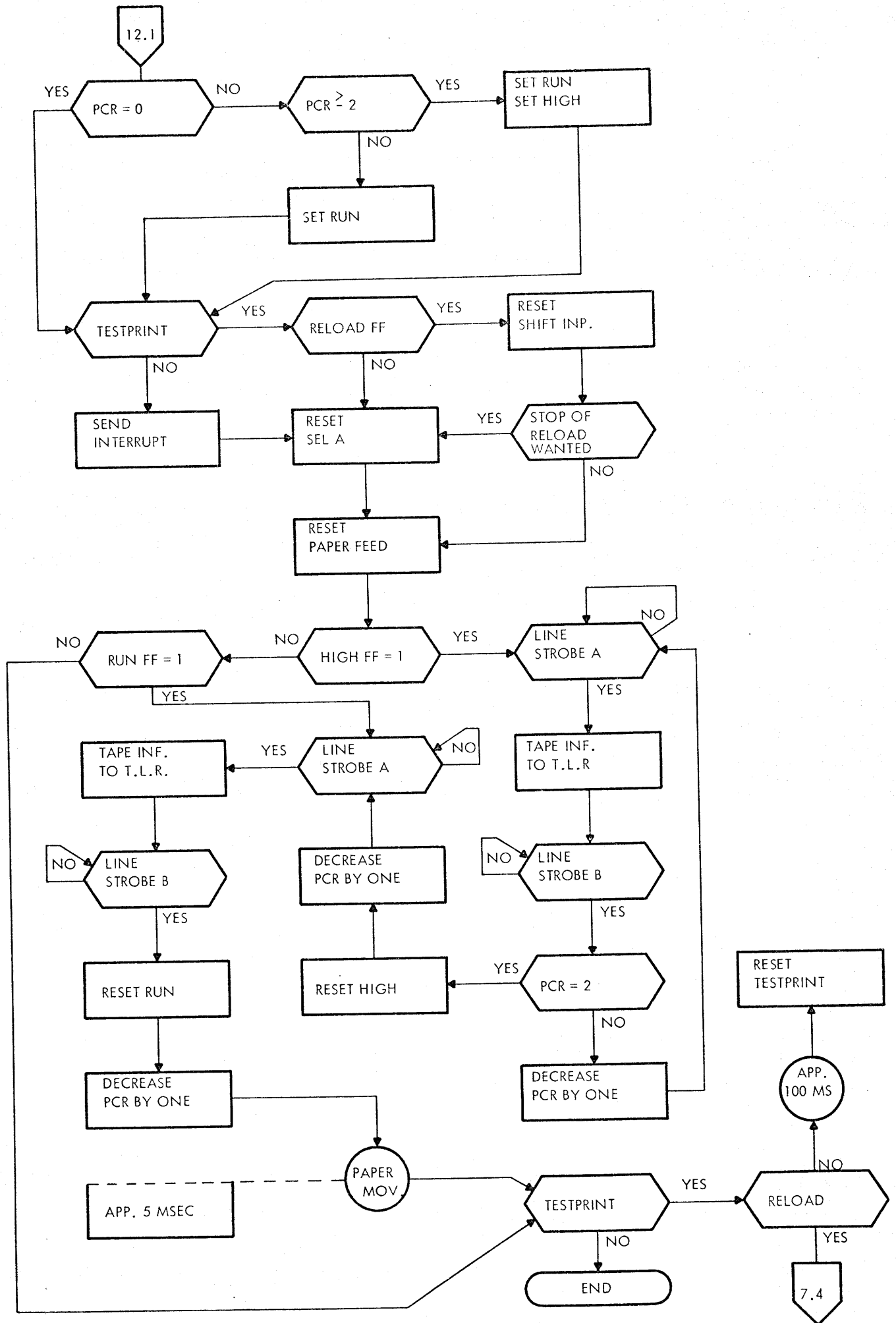

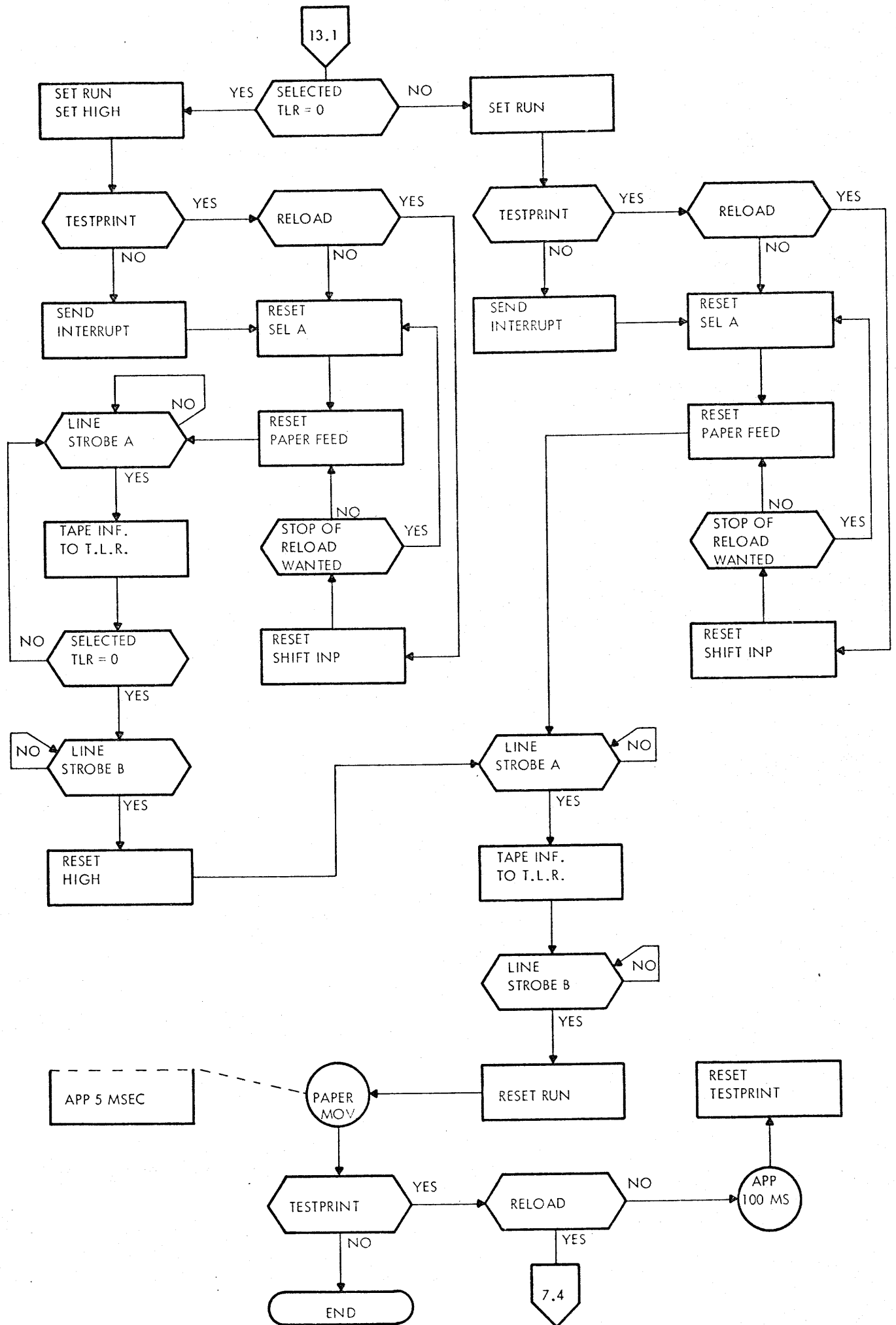

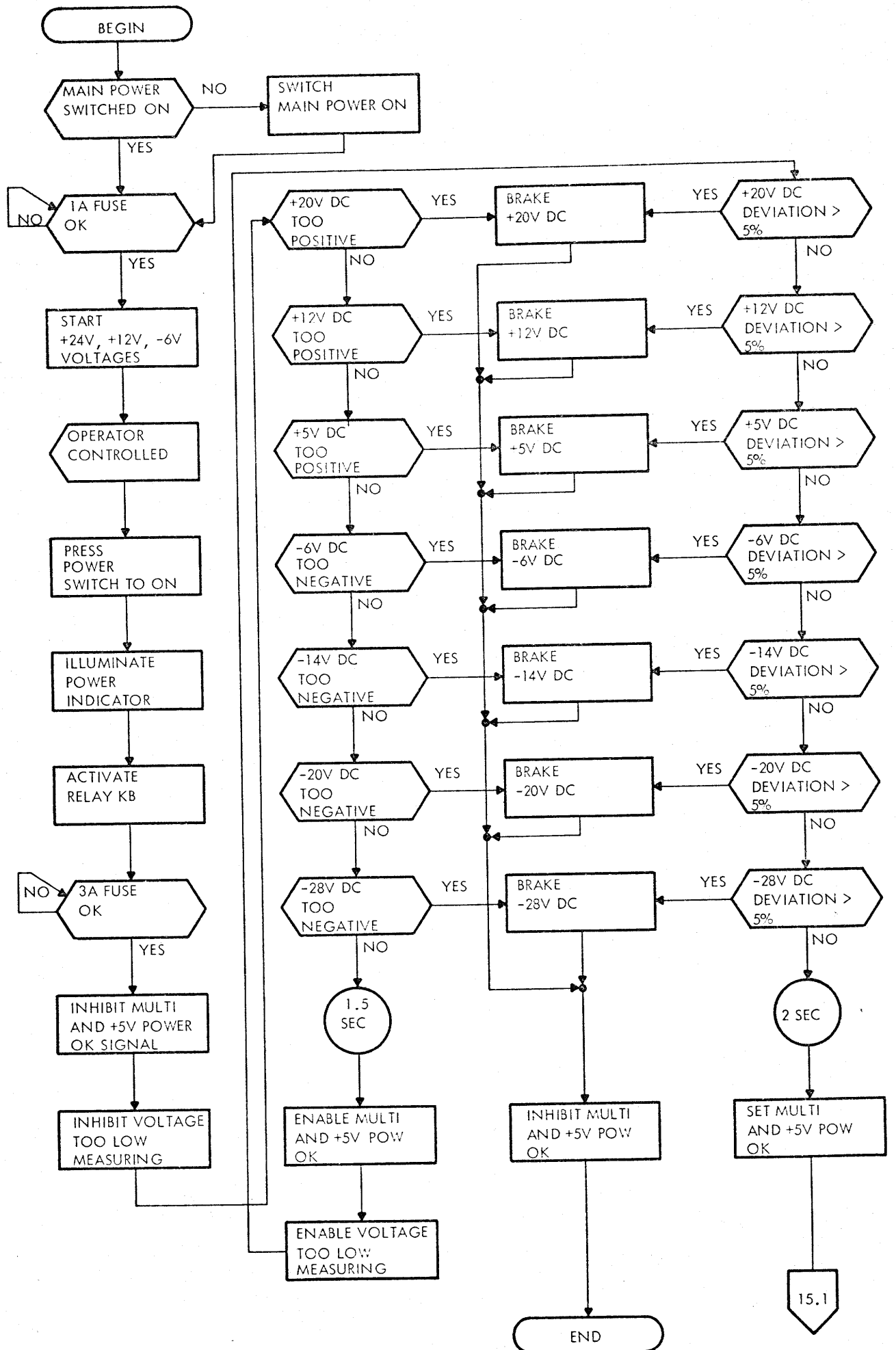

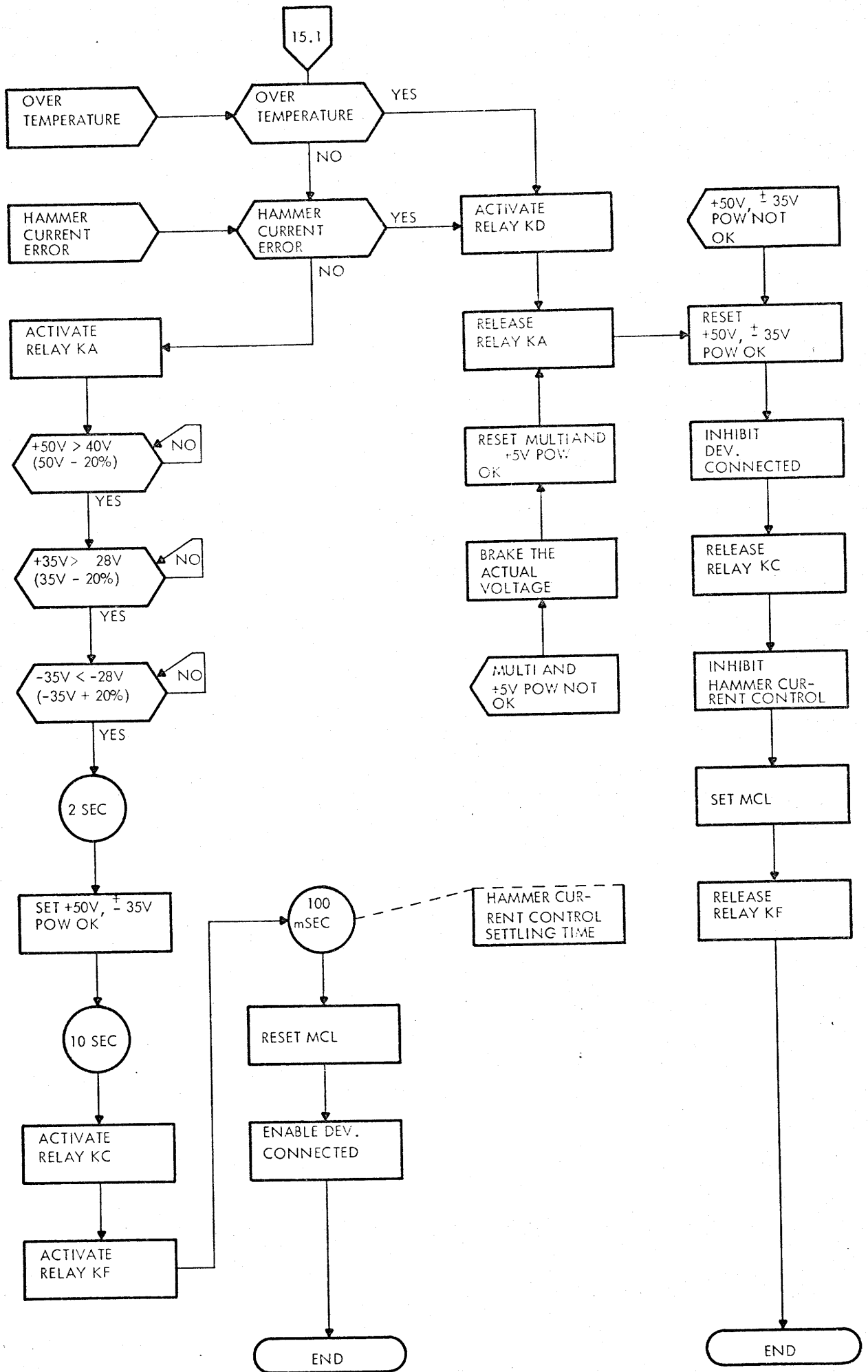

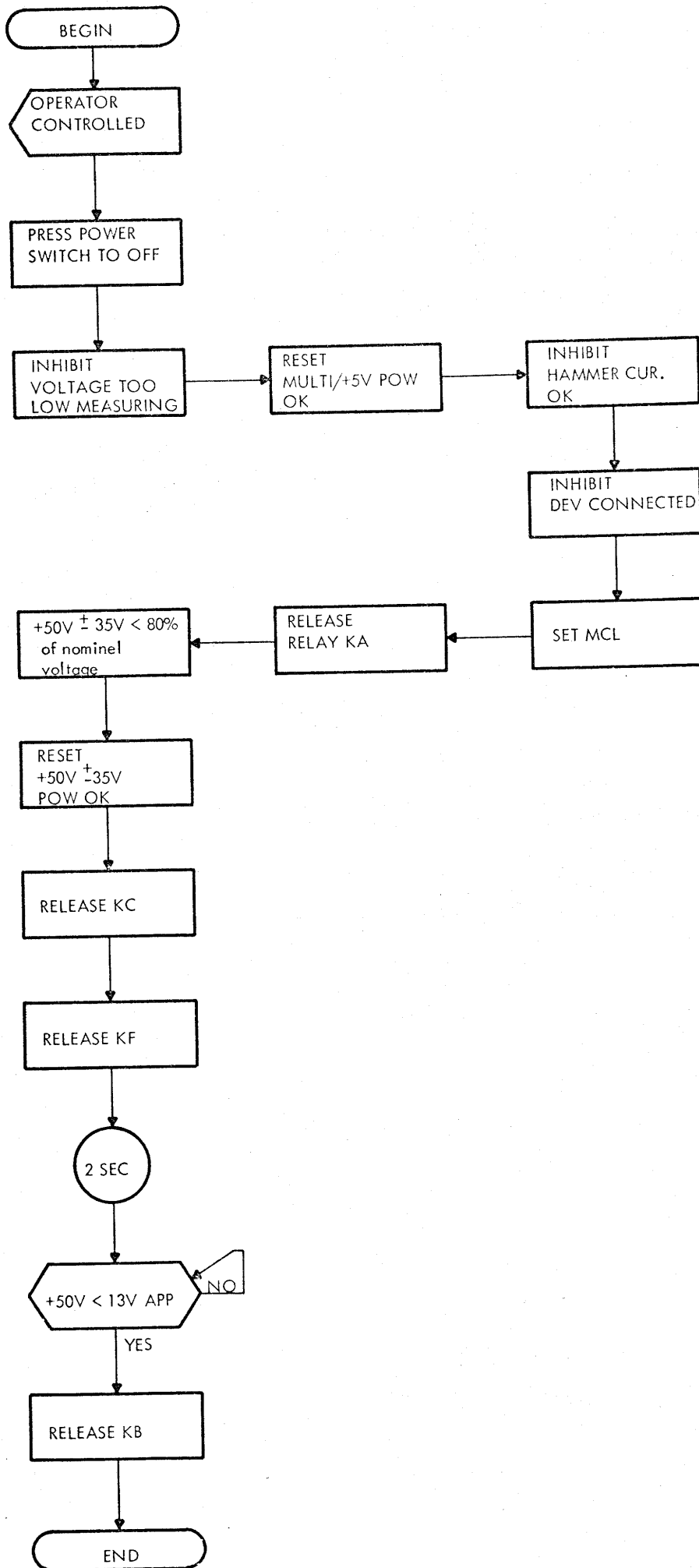

FOR FURTHER INF.
SEE NOTE 1 ON
TIMING CHART
16 AND 17

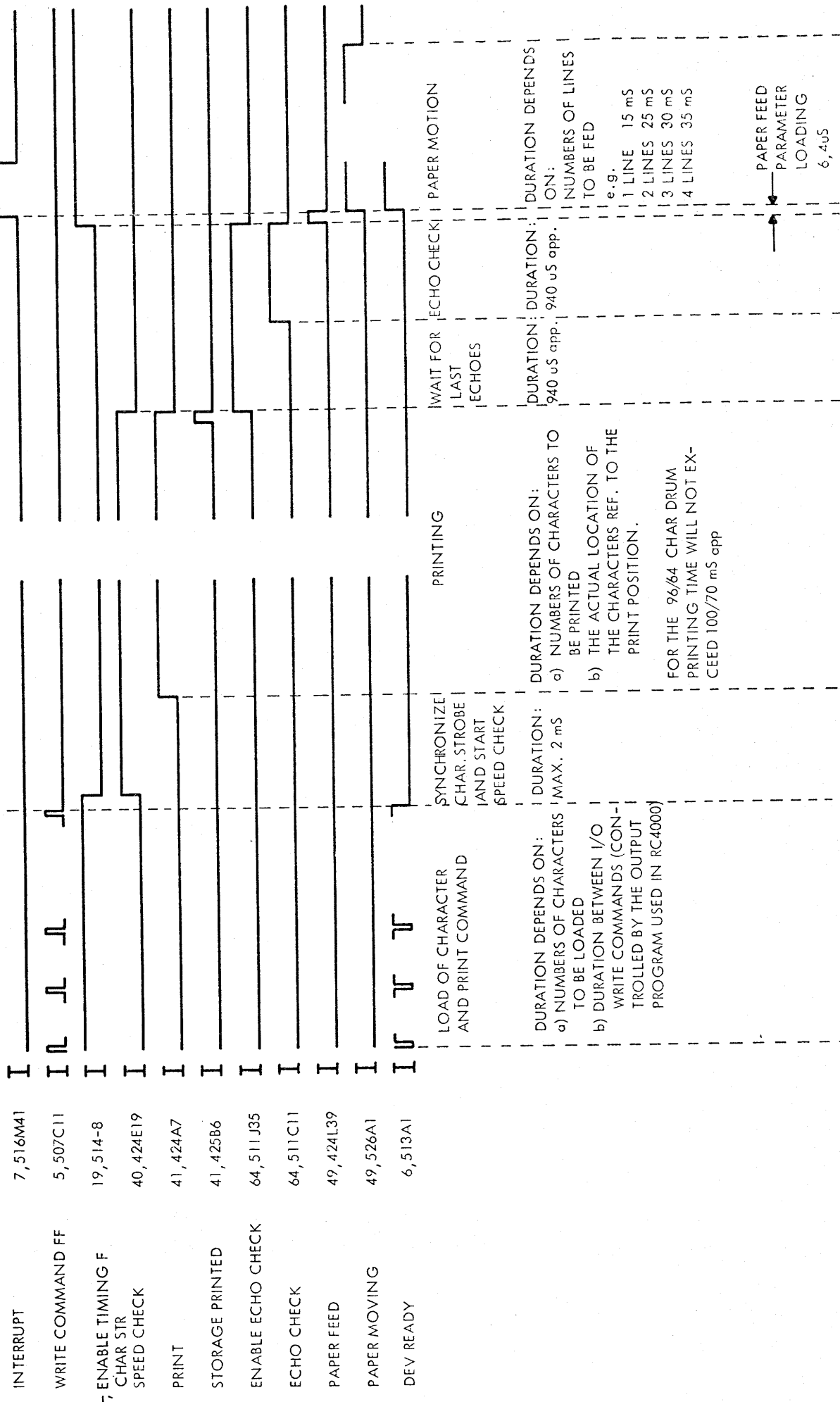

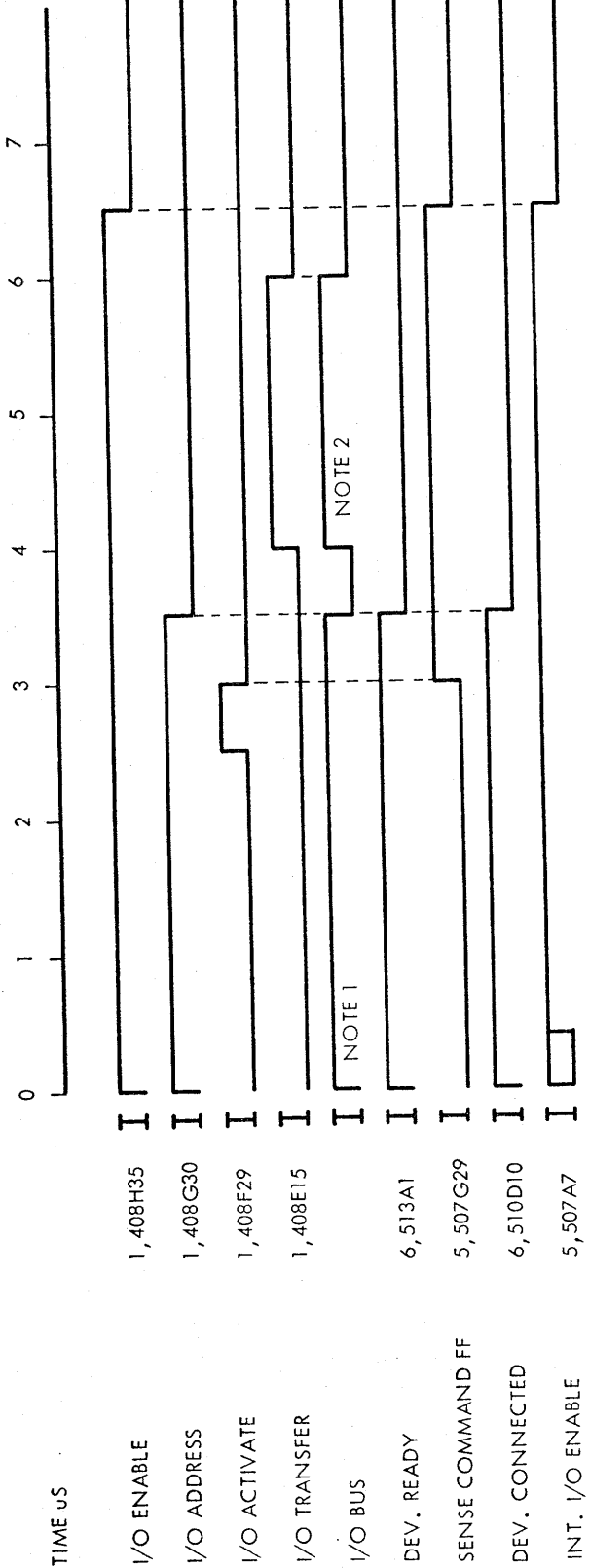

NOTE 1: I/O BUS 0: 17 = DEV. ADDRESS
18: 23 = DEV. COMMAND

NOTE 2: I/O BUS 0: 5 = DEV. STATUS INFORMATION

7,406F33	I/O BUS 0 =	INTERVENTION
7,406E4	- 1 =	PARITY
7,406D1	- 2 =	TIME OUT
7,406C6	- 3 =	NOT USED
7,406B8	- 4 =	NOT USED
7,406A10	- 5 =	INTERVENTION REQUIRED

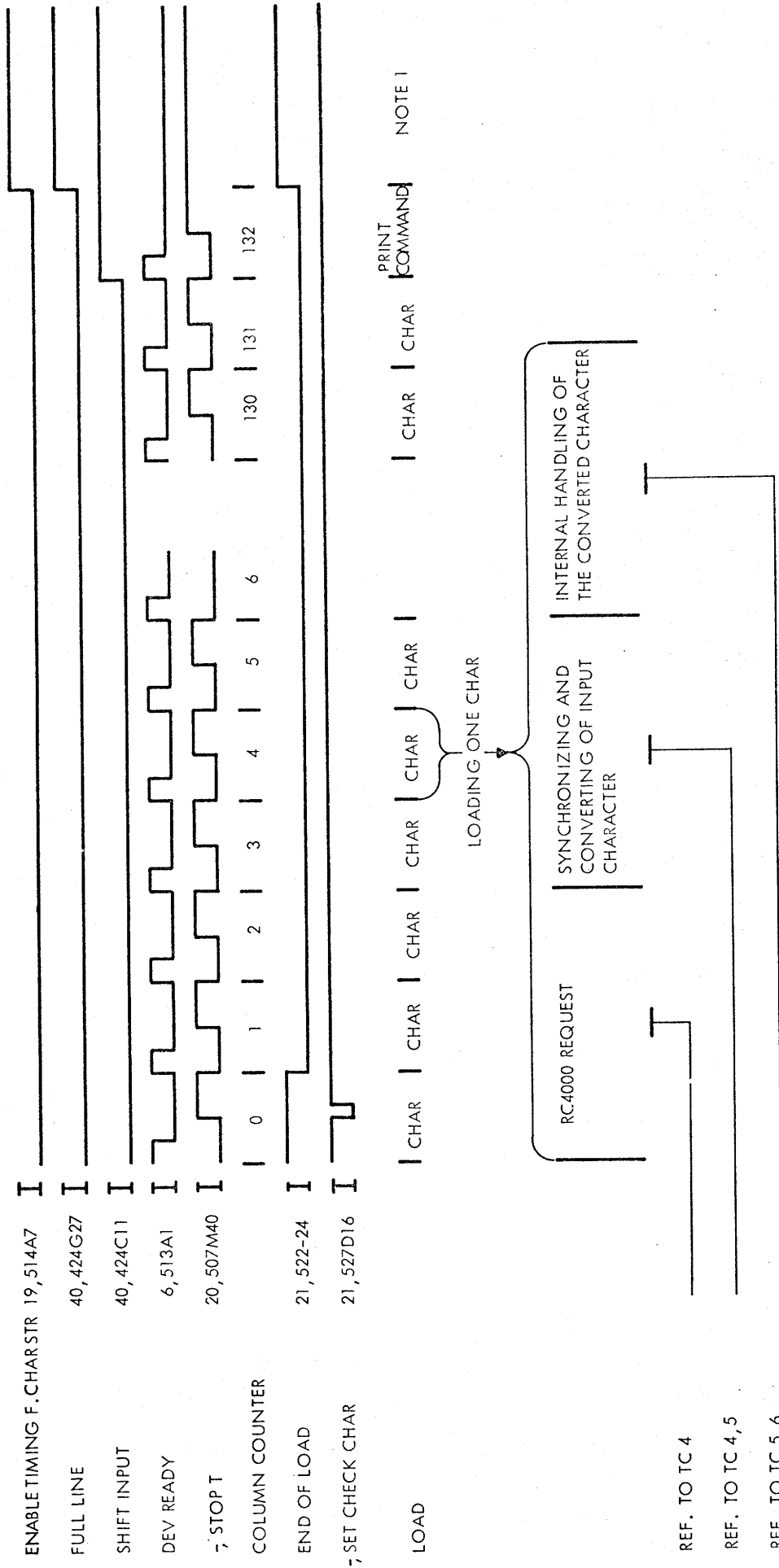

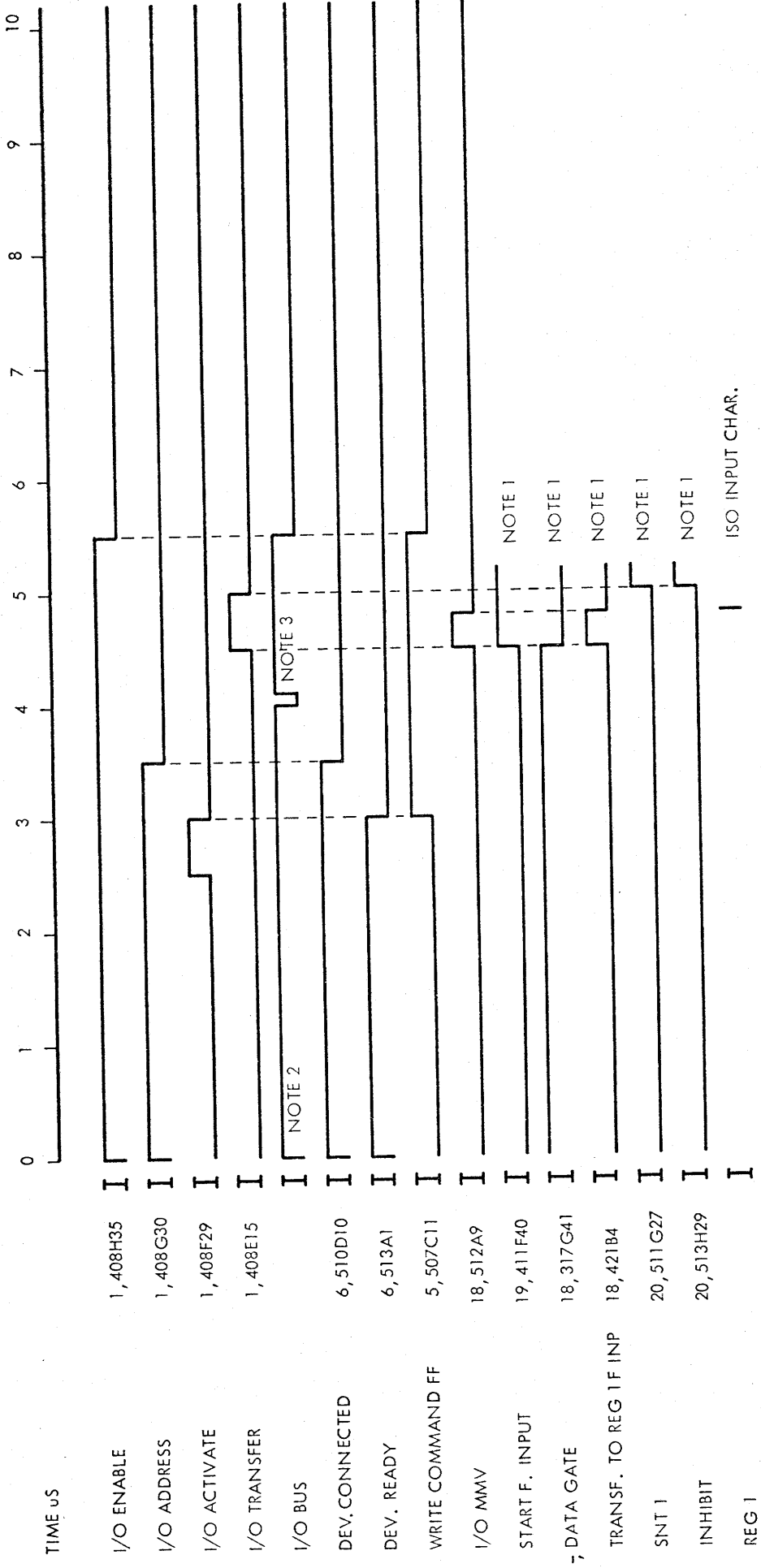

NOTE 1: FOR FURTHER INFORMATION SEE TC 5

NOTE 2: I/O BUS 0: 17 = DEV. ADDRESS
18: 23 = DEV. COMMAND

NOTE 3: I/O BUS 17: 23 = ISO INPUT CHAR.

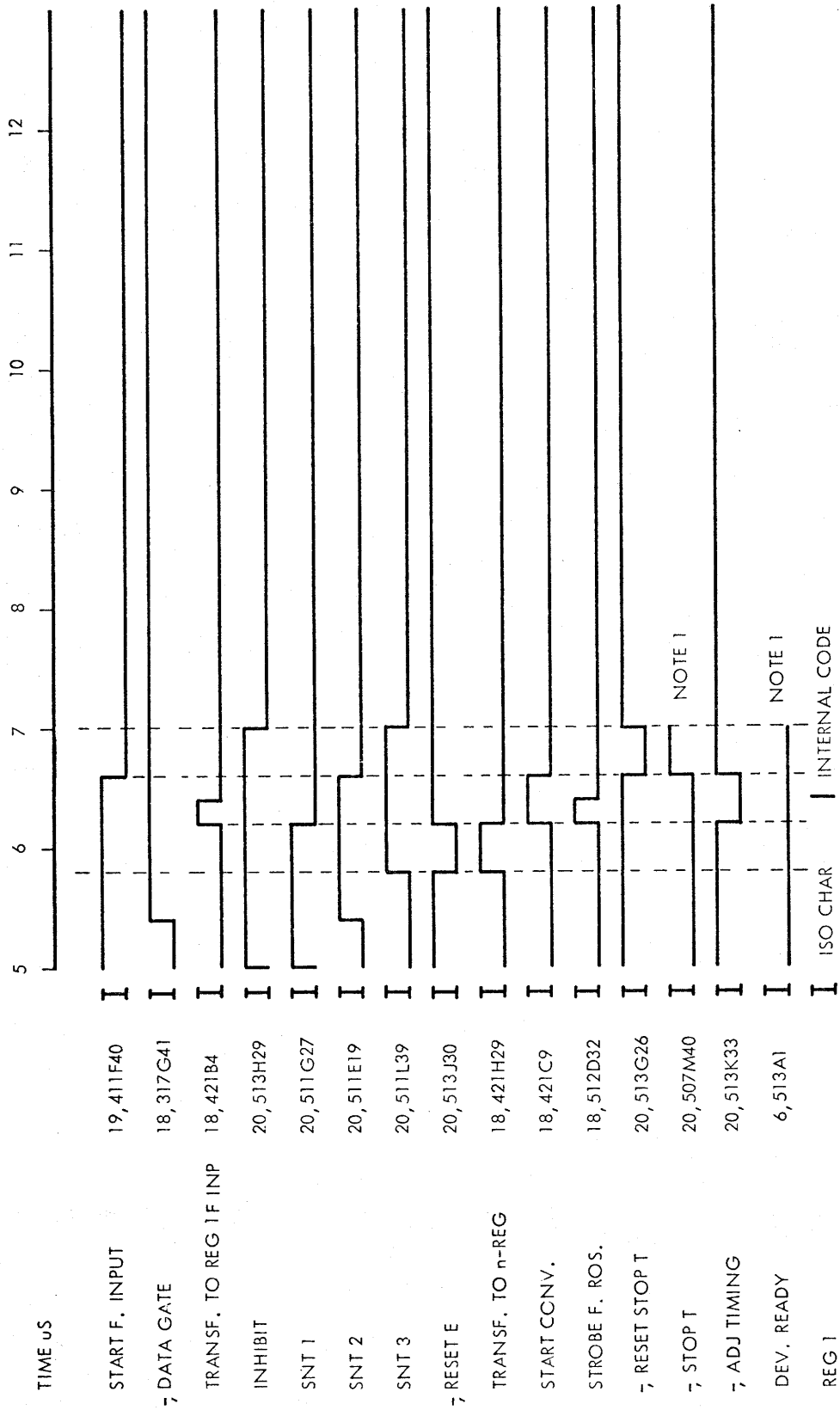

NOTE 1: FOR FURTHER INFORMATION SEE TC 6.

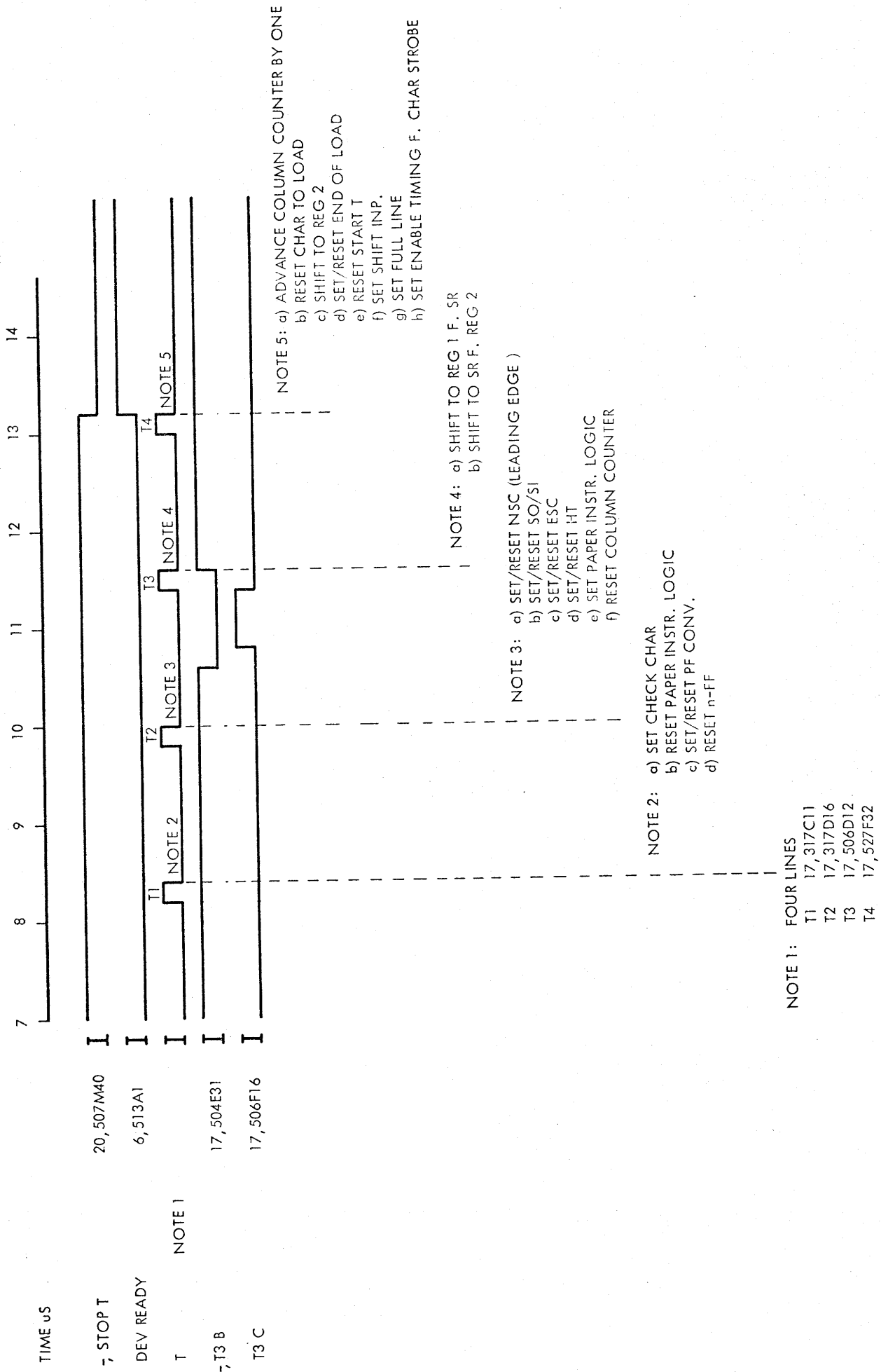



TIME uS

16,501B7
 16,502A7
 17,502J35
 17,502C11
 17,502G27
 17,502E19
 17,502L39
 17,503A2
 17,50586
 17,506A1
 17,505C7
 17,504E31
 17,506F16
 20,513H29
 20,513J30
 20,513K33
 20,513G26
 20,507M40
 16,527A1

TIMING SEQUENCE

INHIBIT AND CLEAR TIMING GENERATOR

NOTE 1: FOUR LINES
 T1 17,317C11
 T2 17,317D16
 T3 17,506D12
 T4 17,527F32

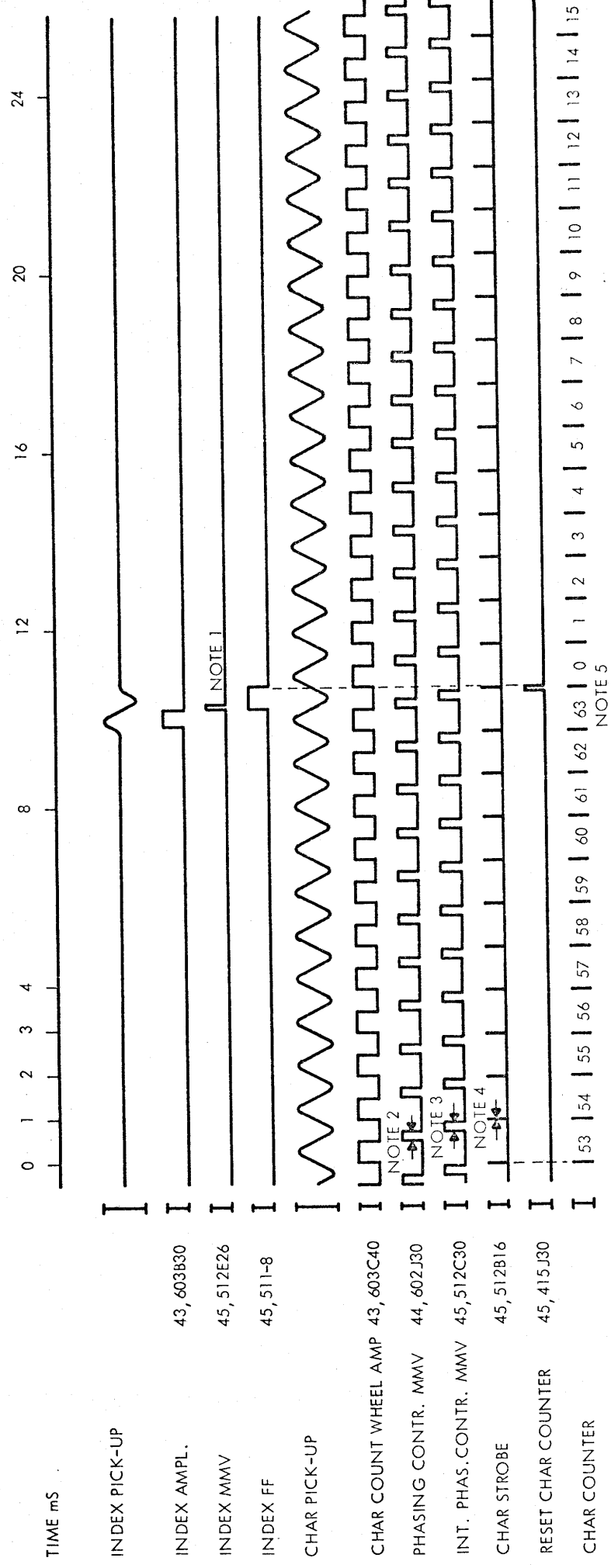

NOTE 1: INDEX MMV ADJUSTED TO 1,5 μ S
 NOTE 2: PHASING CONTROL MMV NOMINAL DURATION = 230 μ S, ADJUSTABLE FROM 50 μ S TO 455 μ S
 NOTE 3: INT. PHASING CONTROL MMV NOMINAL DURATION = 230 μ S, ADJUSTABLE FROM 50 μ S TO 455 μ S
 NOTE 4: CHAR STROBE NOMINAL DURATION = 1 μ S ADJUSTABLE FROM 0,6 μ S TO 1,2 μ S
 NOTE 5: CHAR COUNTER TERMINATION VALUE DEPENDS ON CHAR DRUM HERE SHOWN FOR 64 CHAR.

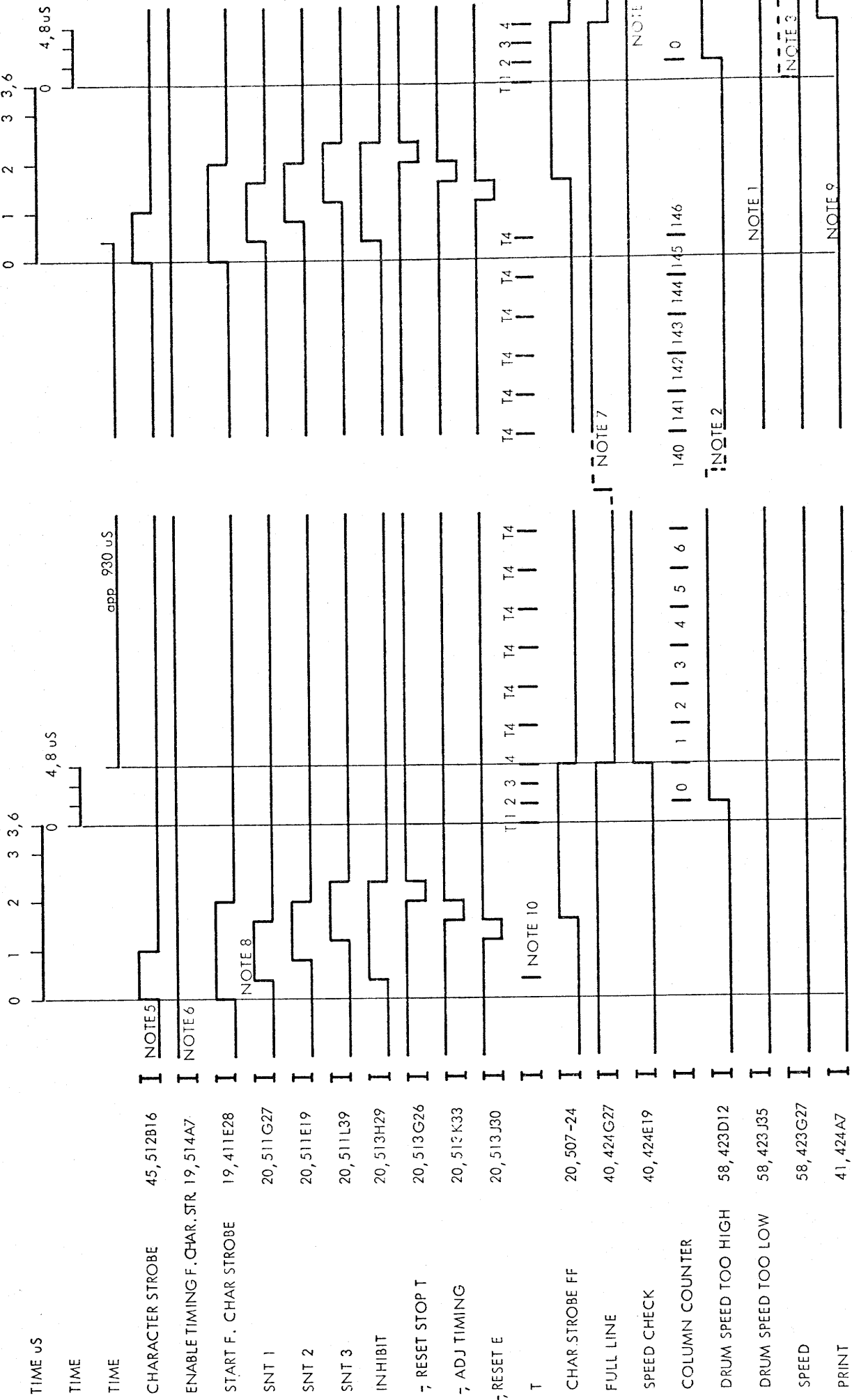

NOTE 1: DRUM SPEED TOO LOW IS SET IF CC = 154 & T1
 NOTE 2: DRUM SPEED TOO HIGH IS RESET IF CC = 138 & T1
 NOTE 3: SPEED IS SET IF CC < 138 ! CC > 154
 NOTE 4: FOR SPEED CHECK TERMINATION SEE TC 13
 NOTE 5: MAX. DELAY TO LEADING EDGE OF CHAR STR = app 940 μs
 NOTE 6: FOR SETTING ENABLE TIMING F. CHAR STROBE REFER TO TC 6
 NOTE 7: FULL LINE IS SET AT CC = 132 & T4
 NOTE 8: MAX. DELAY FROM START F. CHAR. STROBE TO SNT 1 = 400 nS
 NOTE 9: FOR PRINT SEE TC 10
 NOTE 10: T-PERIOD, SEE TC 7

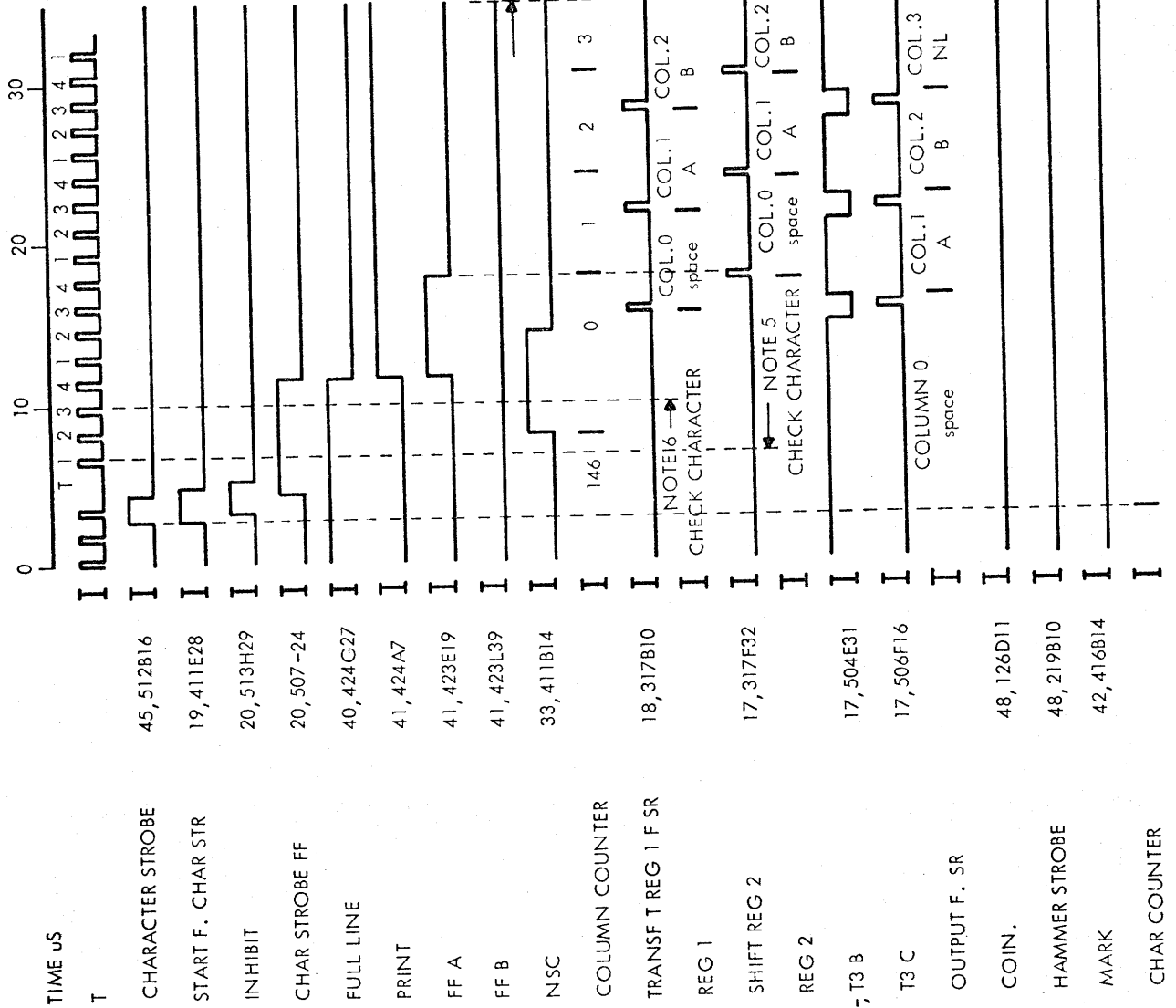

NOTE 1: STROBES FOR THE CHARACTERS F, E, D, C, ...
 NOTE 2: DURATION DEPENDS ON THE CHAR DRUM ROTATIONAL DELAY
 NOTE 3: FOR FURTHER INFORMATION SEE TC 11

NOTE 4: NOT SHOWN TO SCALE
 NOTE 5: CHECK OF THE CHECK CHARACTER
 NOTE 6: CHECK PARITY AT T3 DURING THE ENTIRE ENABLE TIMING
 F. CHAR STROBE PERIOD. TERMINATED ON TC 15

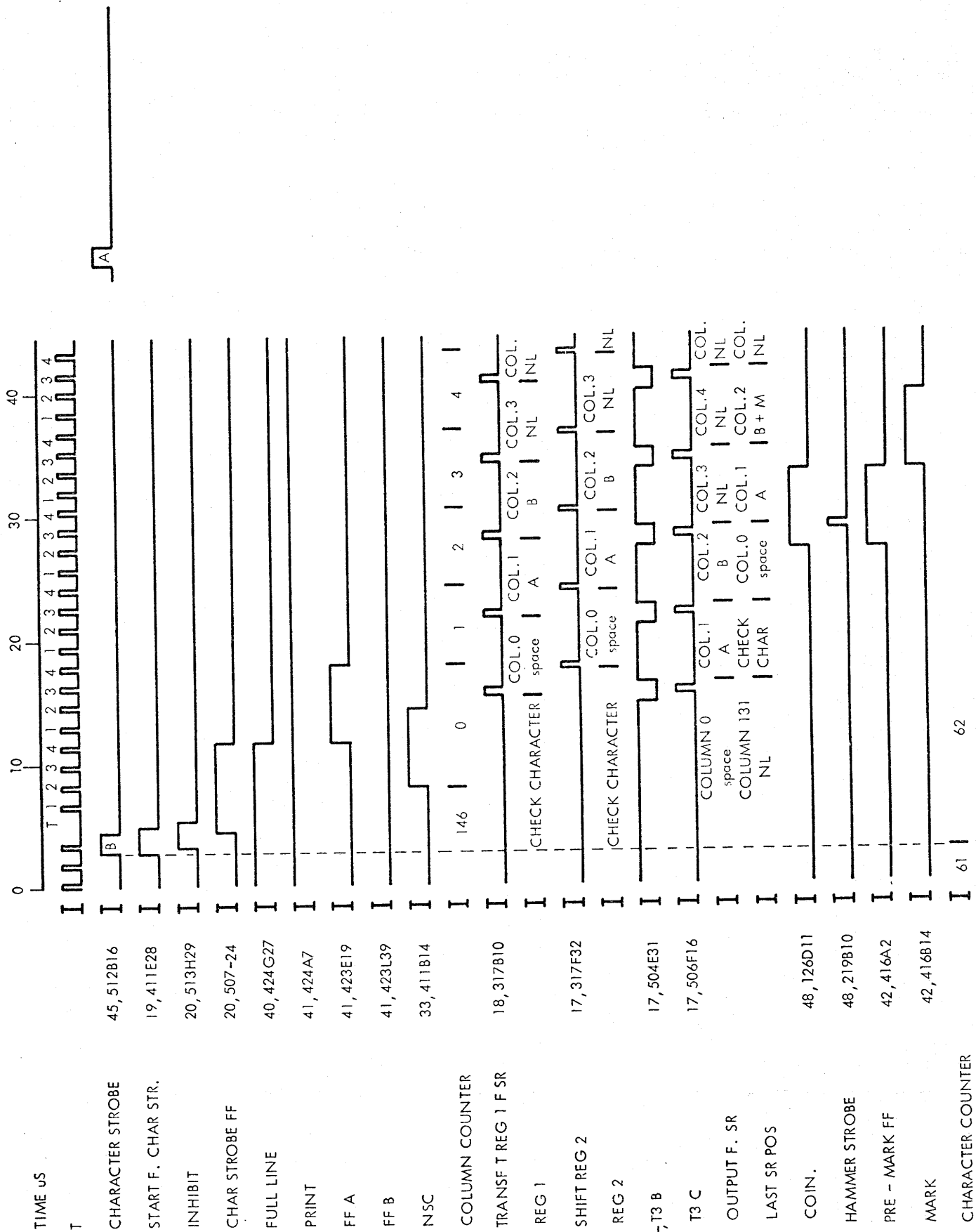

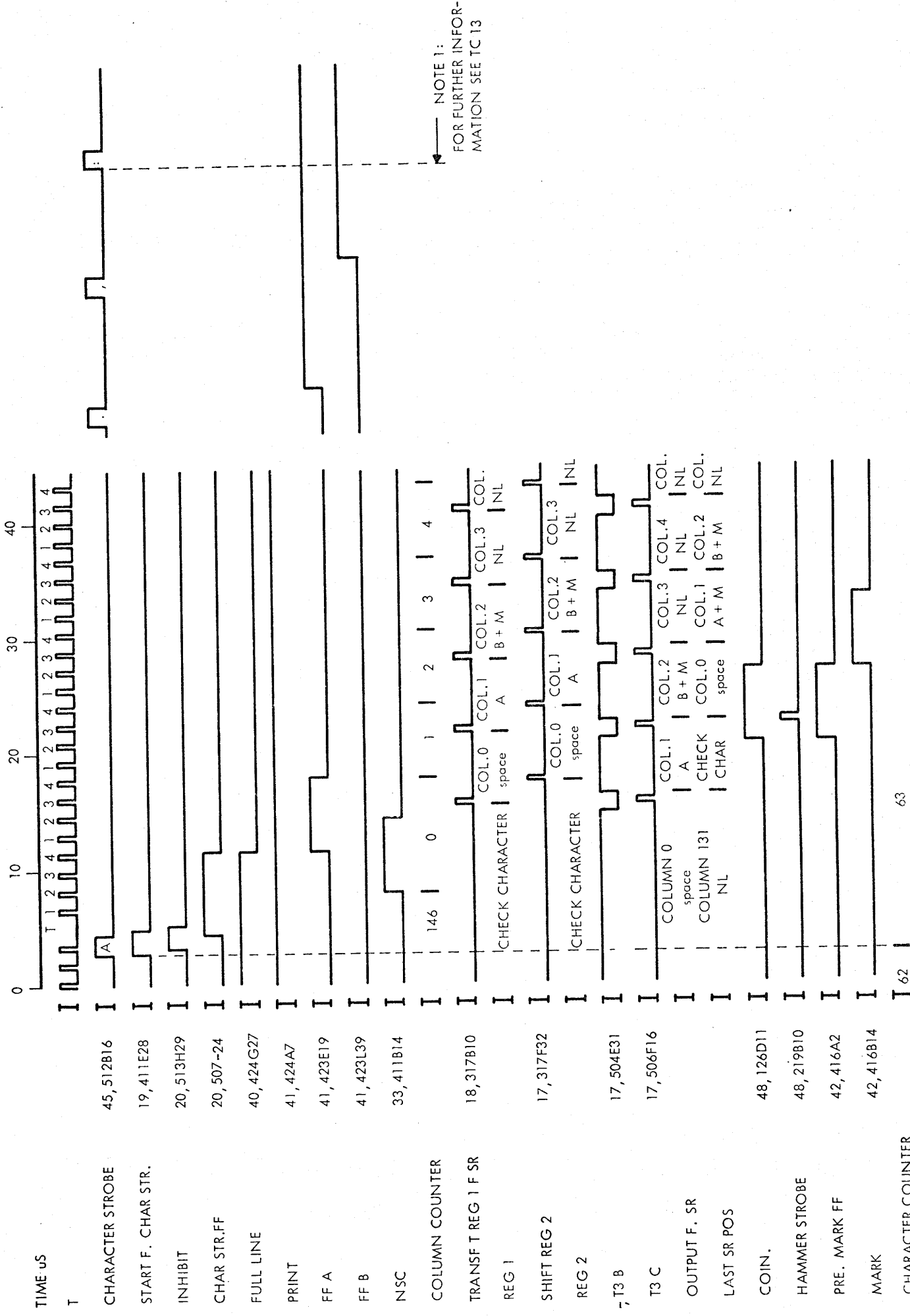

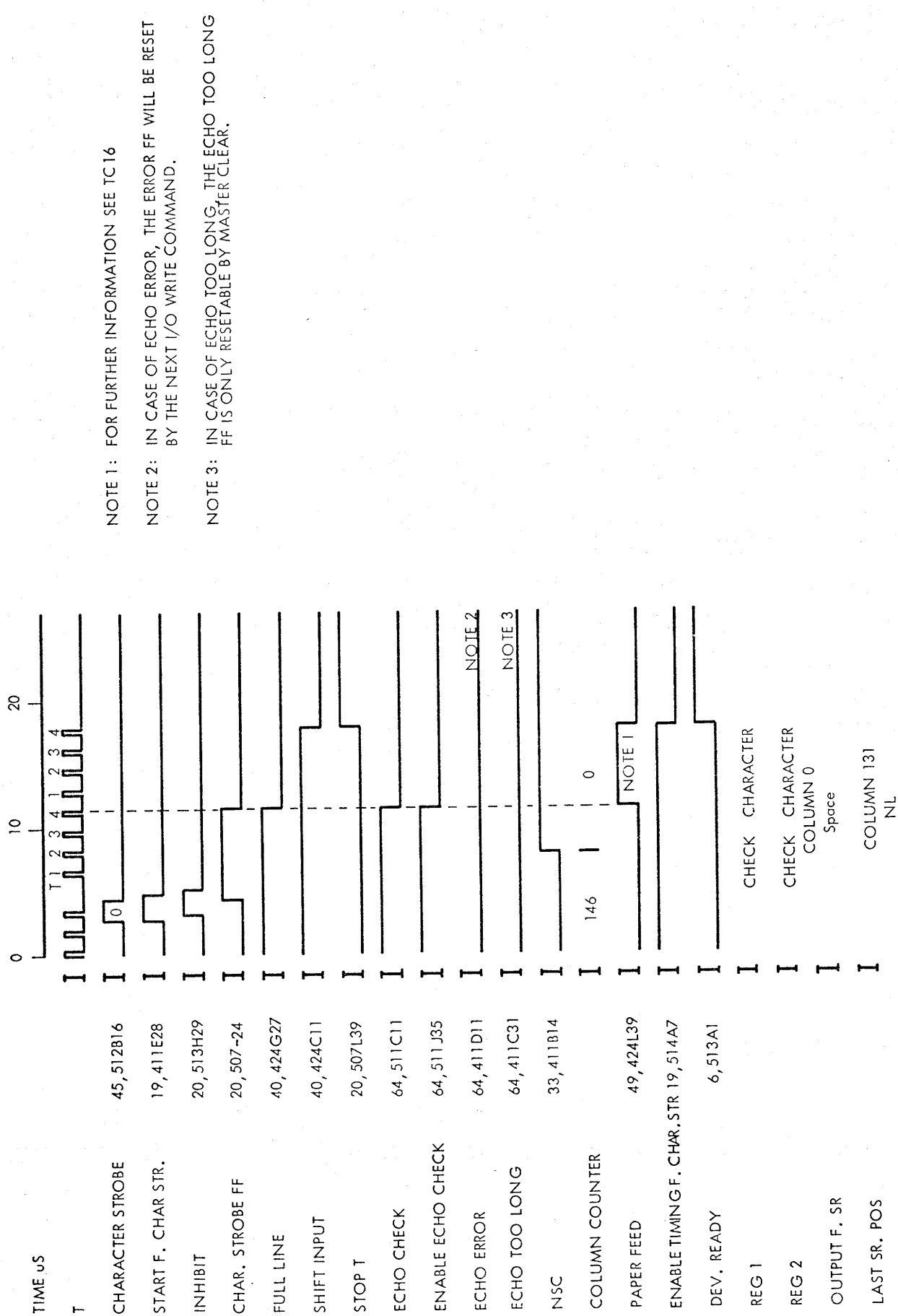

Timing Chart

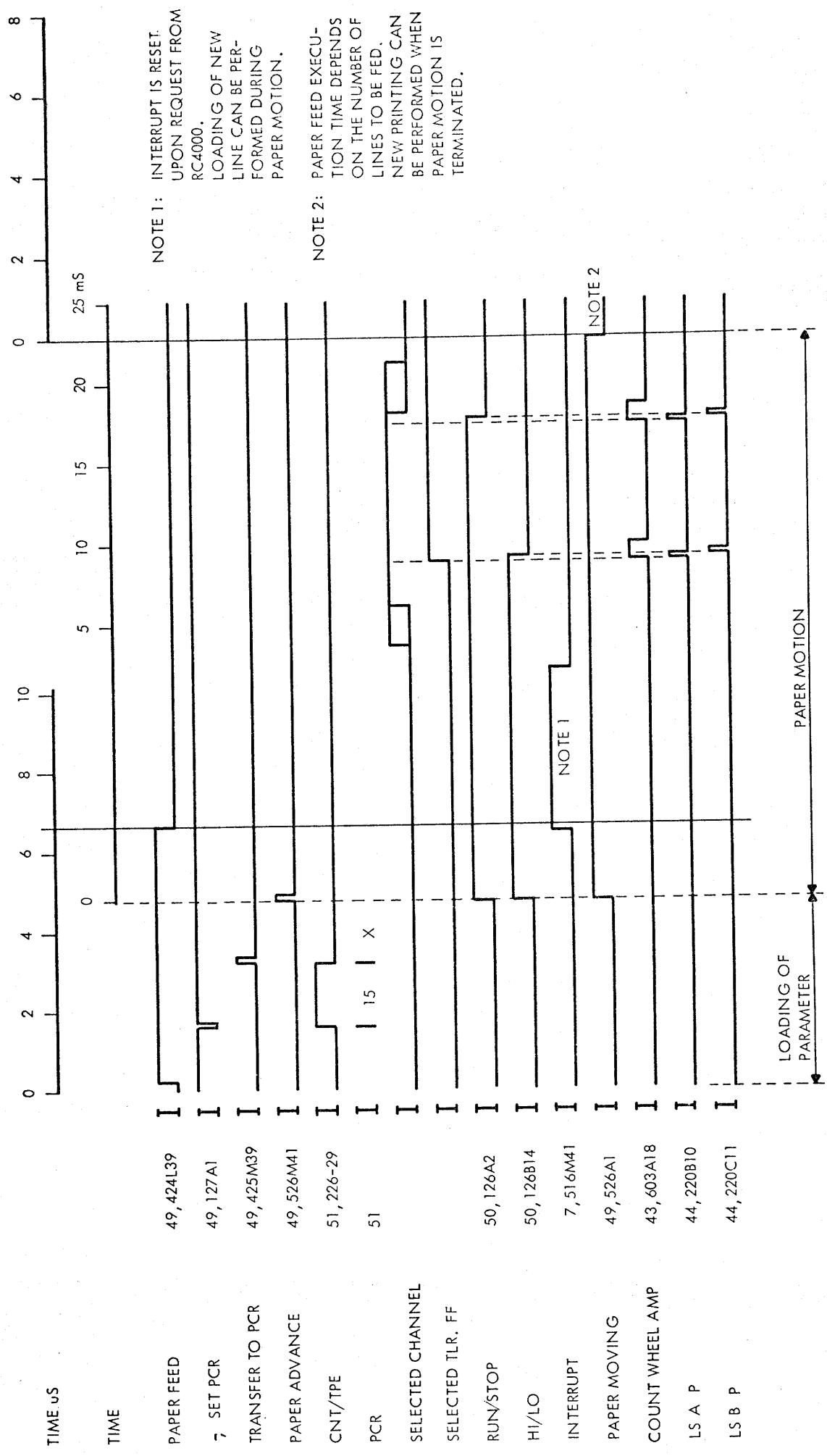

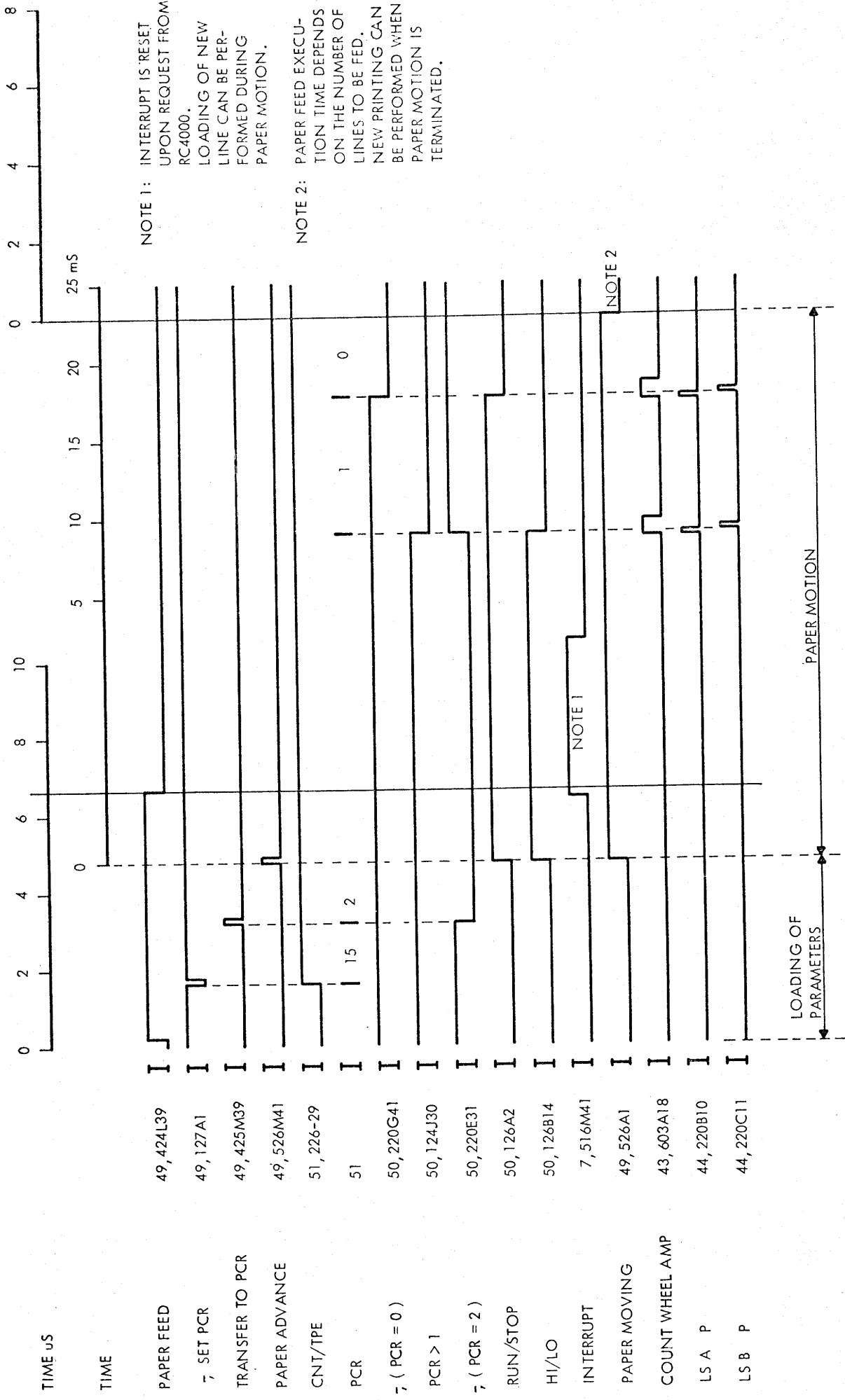

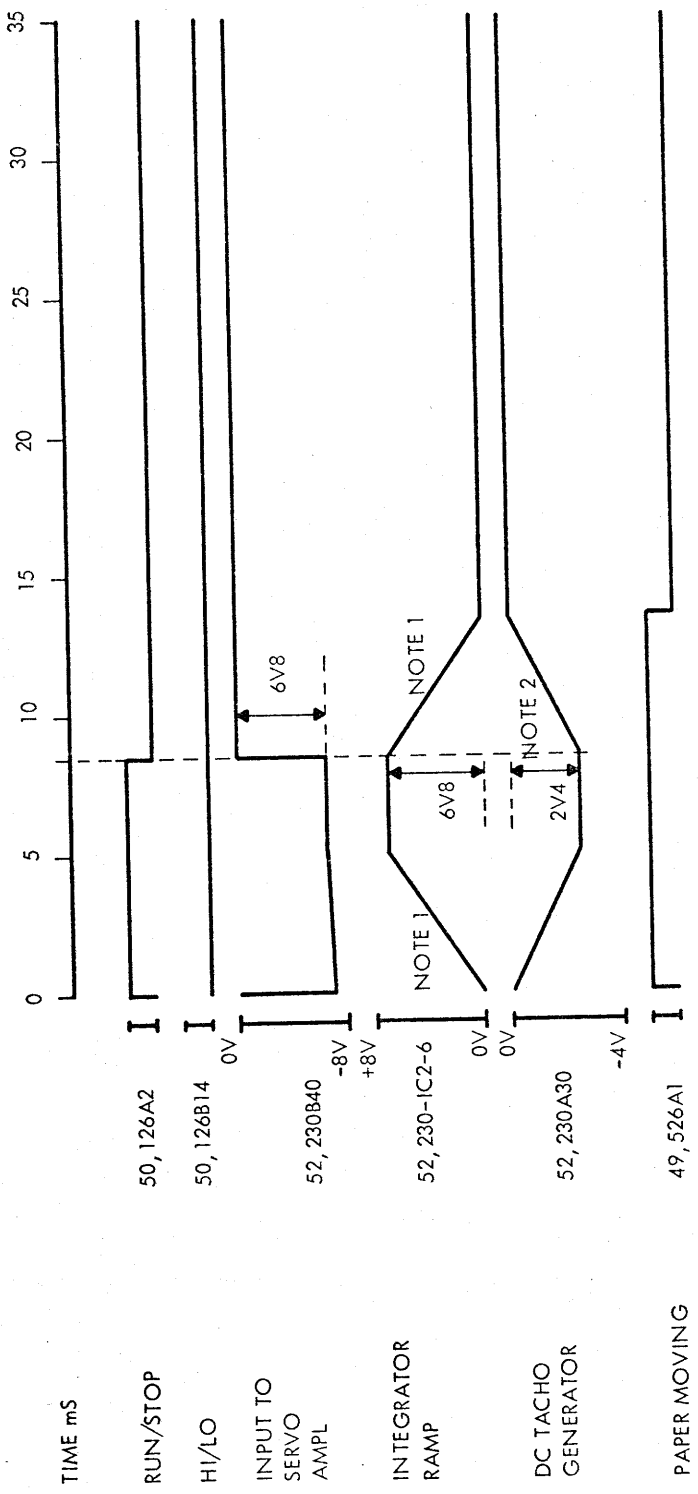

NOTE 1: SLOPE 1V36 per mS (FASTE RISE)
 NOTE 2: 2V4 corresponds to 370 rpm corresponds to 20 ips paper speed.

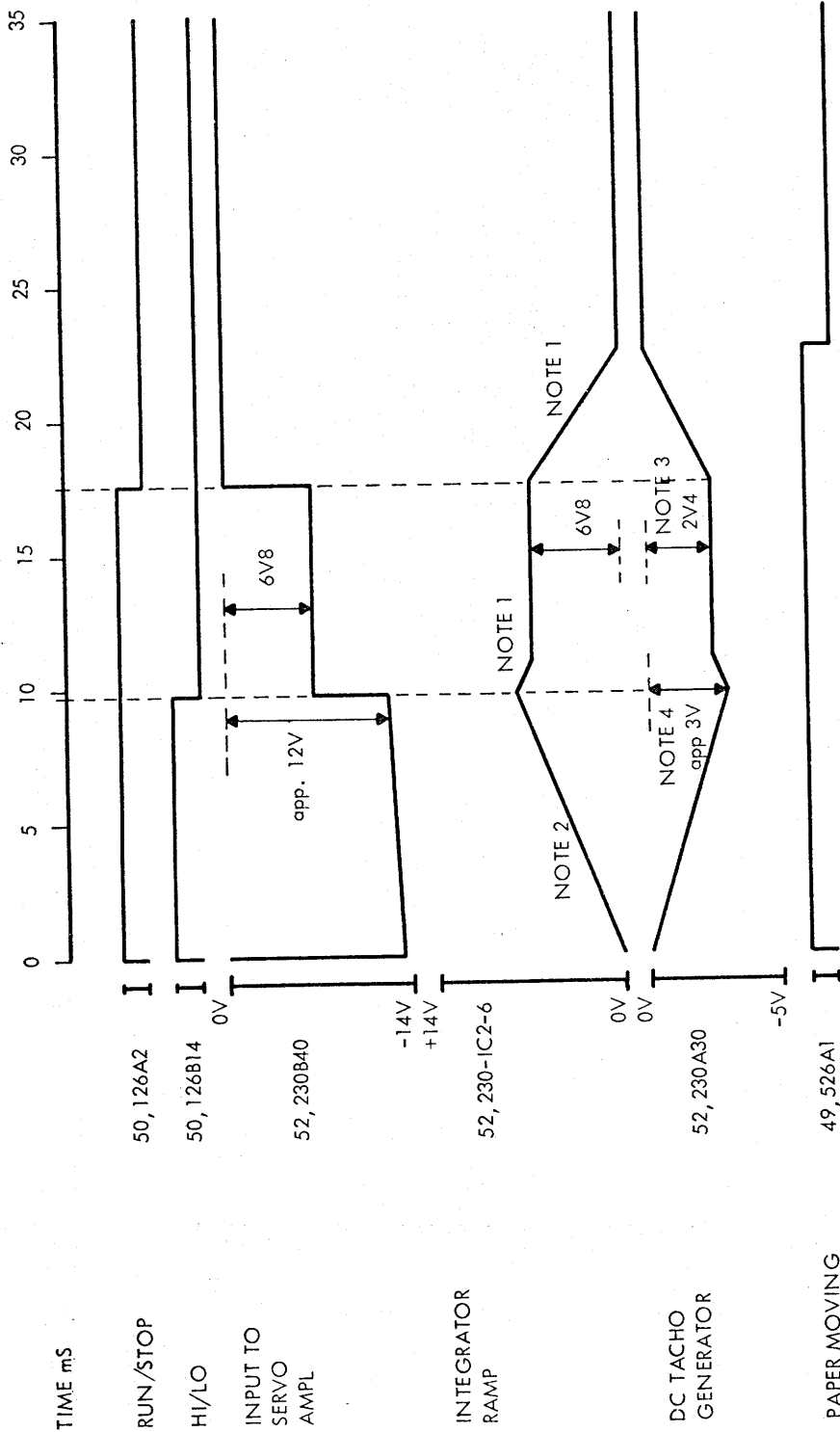

NOTE 1: SLOPE 1V36 per mS (FAST RISE)
 NOTE 2: SLOPE 0V86 per mS (SLOW RISE)
 NOTE 3: 2V4 corresponds to 370 rpm corresponds to 20 ips paper speed
 NOTE 4: 3V - - 25 - -
 - 460 - -

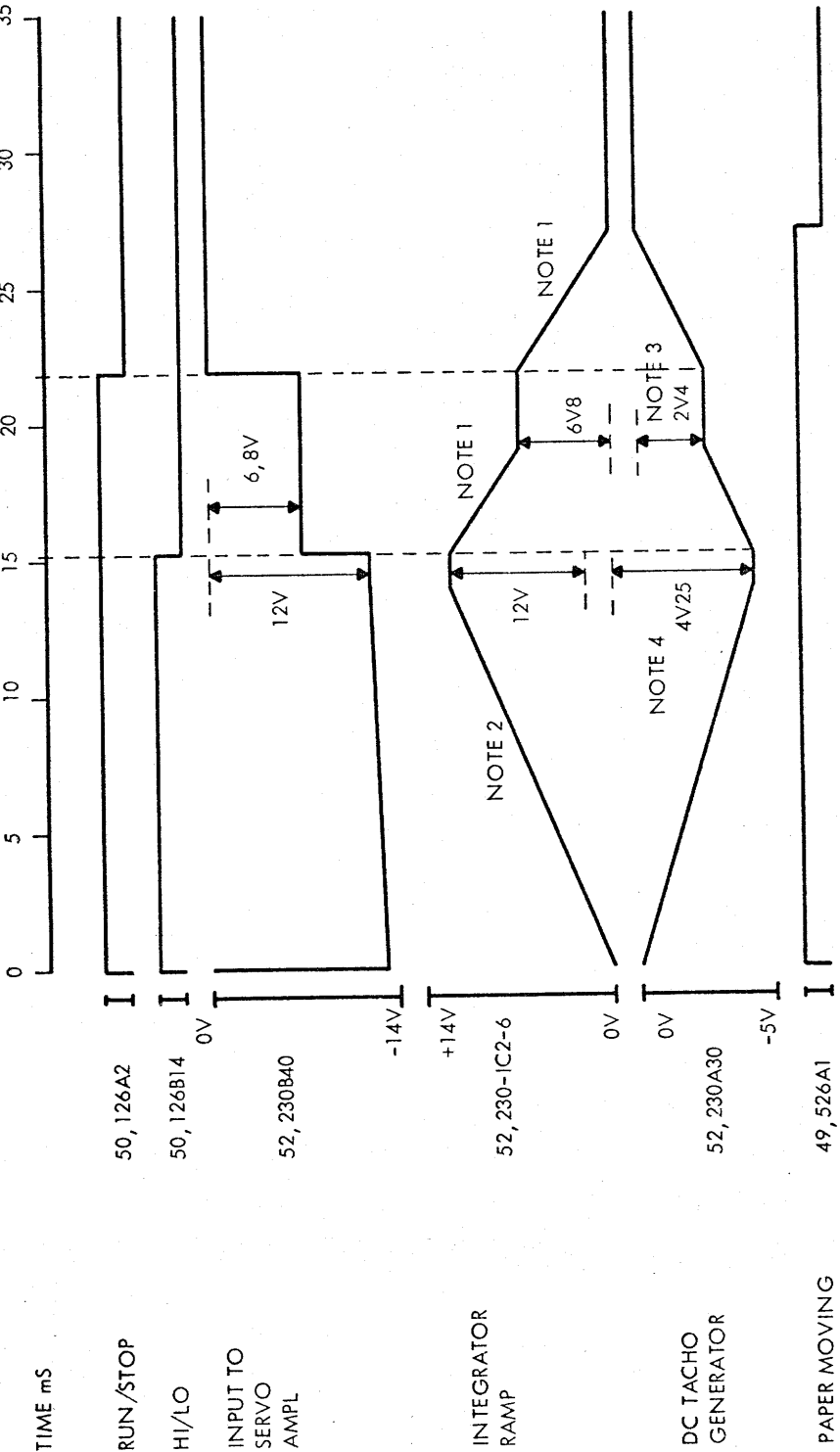

NOTE 1: SLOPE 1V36 per mS (FAST RISE)
 NOTE 2: SLOPE 0V86 per mS (SLOW RISE)
 NOTE 3: 2V4 corresponds to 370 rpm
 NOTE 4: 4V25 corresponds to 20 ips paper speed



SCANDINAVIAN INFORMATION PROCESSING SYSTEMS

**HEADQUARTERS: FALKONER ALLÉ 1 . DK-2000 COPENHAGEN F . DENMARK
TELEPHONE: (01) 105366 . TELEX: 6282 RCHQ DK . CABLES: REGNECENTRALEN**