



TABLE OF CONTENTS

RCLM400 PCBA CIRCUIT DIAGRAMS

RC 4000 Basic System
=====

<u>PCBA No.</u>	<u>Circuit on the PCBA</u>	<u>Dwg. No.</u>
RC0834-1	12 AC401	V10767
RC0834-2	12 AM401	V12038
RC0835-1	6 BC401	V10926
RC0836-1	5 AC404	V20681
RC0837-1	3 BB401	V20563
RC0838-1	4 AC403	V20682
RC0839-1	7 AC402	V20561
RC0843-1	9 BA401	V10783
RC0844-1	2 BG401	V10031
RC0845-1	1 BG402	V10046
RC0846-1	2 AJ401	V10049
RC0846-3	2 AJ404	V11127
RC0847-1	7 AG401	V11099
RC0848-1	1 AK401	V10789
RC0849-1	4 AA401	V20093
RC0850-1	1 AJ402	V11888
RC0850-2	1 AJ403	V11562
RC0852-1	6 AA402, 2 AA403	V10766
RC0853-2	6 DA406	V11578
RC0853-5	6 DA421	
RC0854-1	1 BG403	V10053
RC0855-1	1 AA403, 2 AA404	V11101
RC0856-7	7 DA418, 1 DA419	
RC0857-1	1 AF401	V11554
RC0858-1	1 AG402	V10746
RC0859-1	1 BG405	V11564 V12320
RC0860-1	4 DA404	V10782
RC0860-2	4 DD402	V11576
RC0861-1	12 DG401	V11100

<u>PCBA No.</u>	<u>Circuit on the PCBA</u>	<u>Dwg. No.</u>
RC0862-1	2 BD401	V10113
RC0863-1	1 BG404	V10124
RC0868-1	1 AL402	V11879
		V11880
RC0869-1	1 BG406	V11889
RC0870-1	1 BA402	V10190
RC0871-1/	4 CB401	V11762 ✓ 12170
RC0872-1	19 DG402	V11061
RC0878-1/	1 SA401	V12010
RC0879-1	1 CC402	V12035
RC0880-1	1 DD404	V12007
		V12008
RC0883-1	3 DF401	V11058
RC0884-1	9 BA403, 1 AA405	V11504
RC0886-1	2AJ406	V11558
		V11559
RC0886-2	2 AJ405	V12009
RC0888-1/	1 CC404	V11441
RC0889-1/	8 DG404	V11577
RC0890-1	11 DB402, 1 DB403	V10460
RC0891-1	12 DC402	V11563
RC0892-1	5 DA405	V11890
RC0893-2	1 FF402	
RC0893-3	1 FF403	
RC0894-1	4 DB404, 1 DB405	V11561
		V11560
RC0897-1	10 DC405	V11505 ✓ 12300
RC0898-1	1 DB406	V11998
RC0899-1	19 DC404	V20477 ✓ 11891
RC0900-1/	4 CA401	V11556 ✓ 12167
RC0901-1	1 AJ408	V10927
RC0902-1	1 ED403	V11883
		V11884
RC0903-1/	1 AJ407, 1 BG407, 1 CC406	V10953
		V12036
RC0905-1	12 DD406	V11114
RC0906-1	6 FB401	V11151

<u>PCBA No.</u>	<u>Circuit on the PCBA</u>	<u>Dwg. No.</u>
RC0907-1	1 FF403, 1 FF404, 1 FF405, 1 DD408, 2 DD407, 1 CA402, 1 DD409	V12037
RC0909-1/ RC0911-1/	6 CB402 1 SA402, 1 CA403, 1 BC401	V11152 V11885 V11886 V11887
RC0913-1	8 DD405	V11876
RC0926-1	13 DB407	V12006
RC0927-1	13 DC406	V11893
RC0928-1	1 CC407	V11894
RC0929-1	1 BF402	V11506 V11507 V11508
RC0932-1	12 DB408	V11895
RC0932-2	6 DB408, 6 DC407	V11896
RC0933-1	8 DB409	V11696
RC0934-1	3 BF403	V11898 ✓ 12168
RC0935-1	3 BD404	V11897 ✓ 12169
RC0936-1	18 DC408	V11899
RC3032-1	12 AD401	A20276

Circuit A

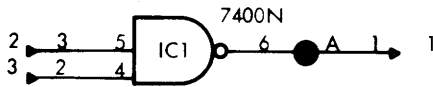

Circuit B

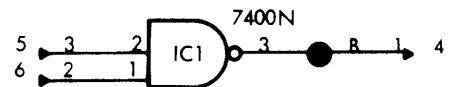

Circuit C

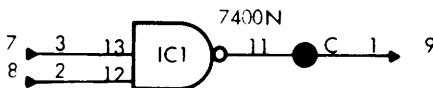

Circuit D

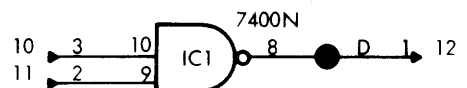

Circuit E

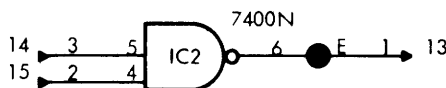

Circuit F

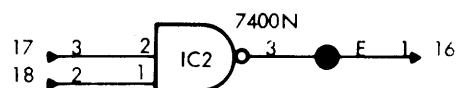

Circuit G

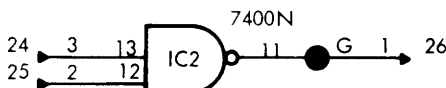

Circuit H

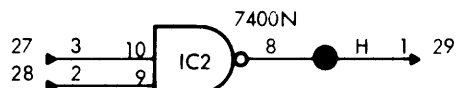

Circuit J

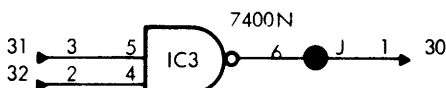

Circuit K

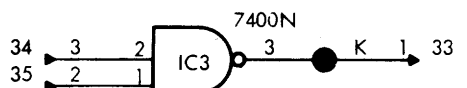

Circuit L

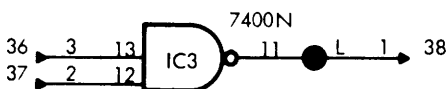

Circuit M

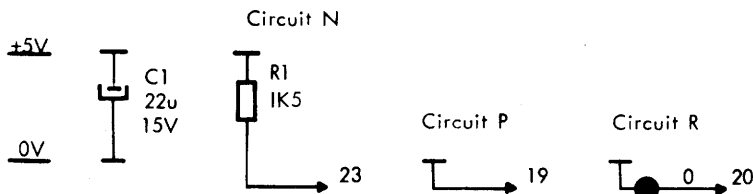
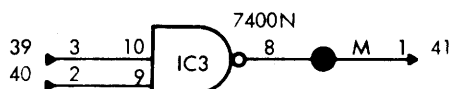

POWER REQUIREMENTS		
+5V	PIN. 22	40 mA
0V	PIN. 21	
POWER DISSIPATION: 210 mW		

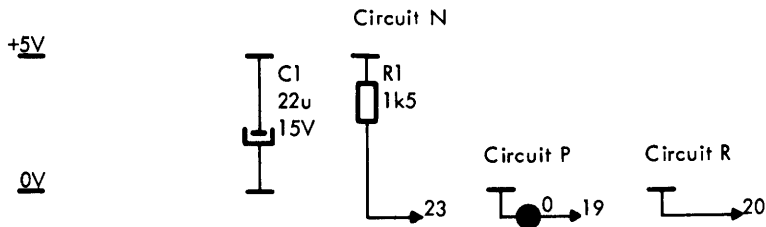
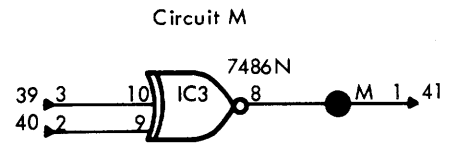
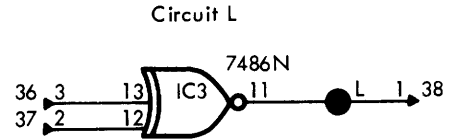
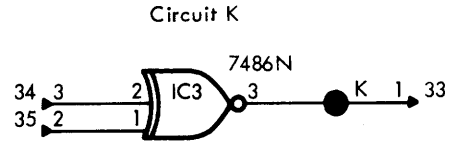
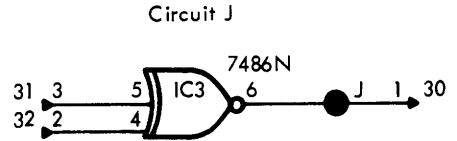
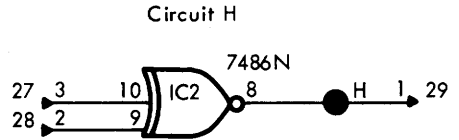
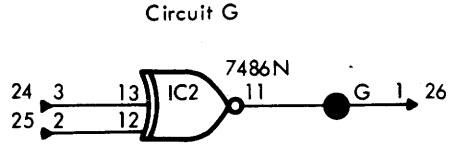
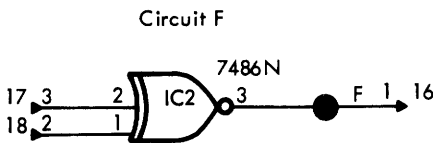
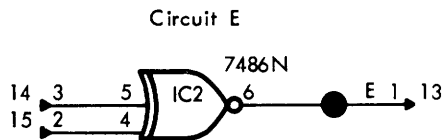
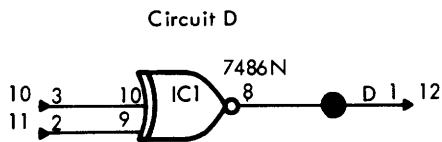
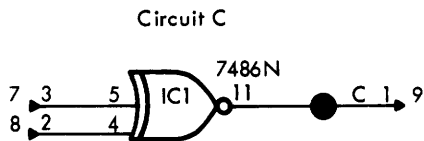
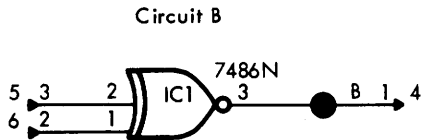
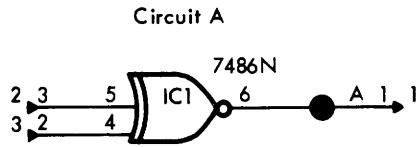

POWER REQUIREMENTS		
+5V	PIN22	150mA
0V	PIN21	
POWER DISSIPATION 79.0mW		

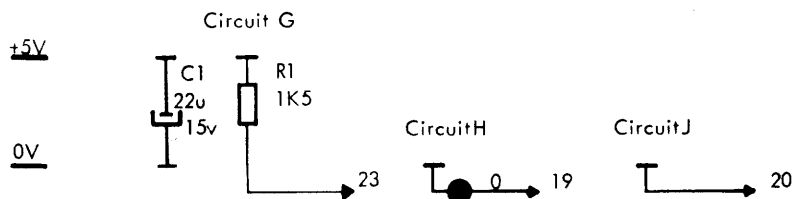
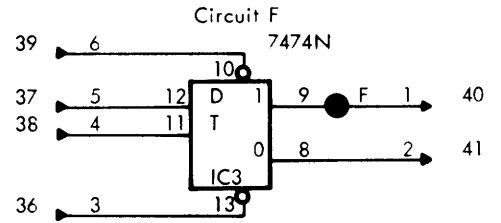
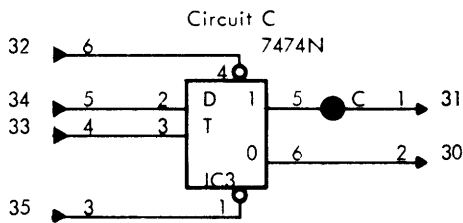
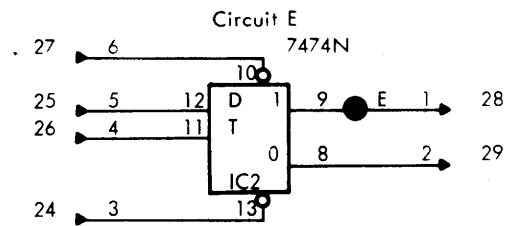
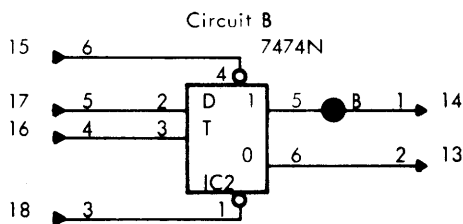
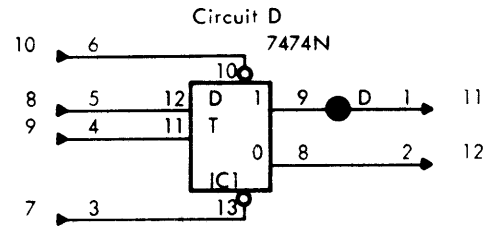
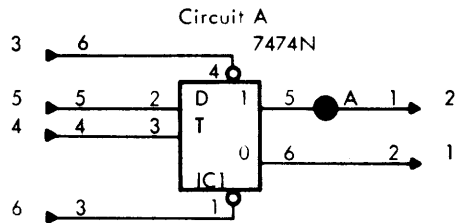

POWER REQUIREMENTS		
+5V	PIN. 22	57 mA
0V	PIN. 21	
POWER DISSIPATION: 295 mW		

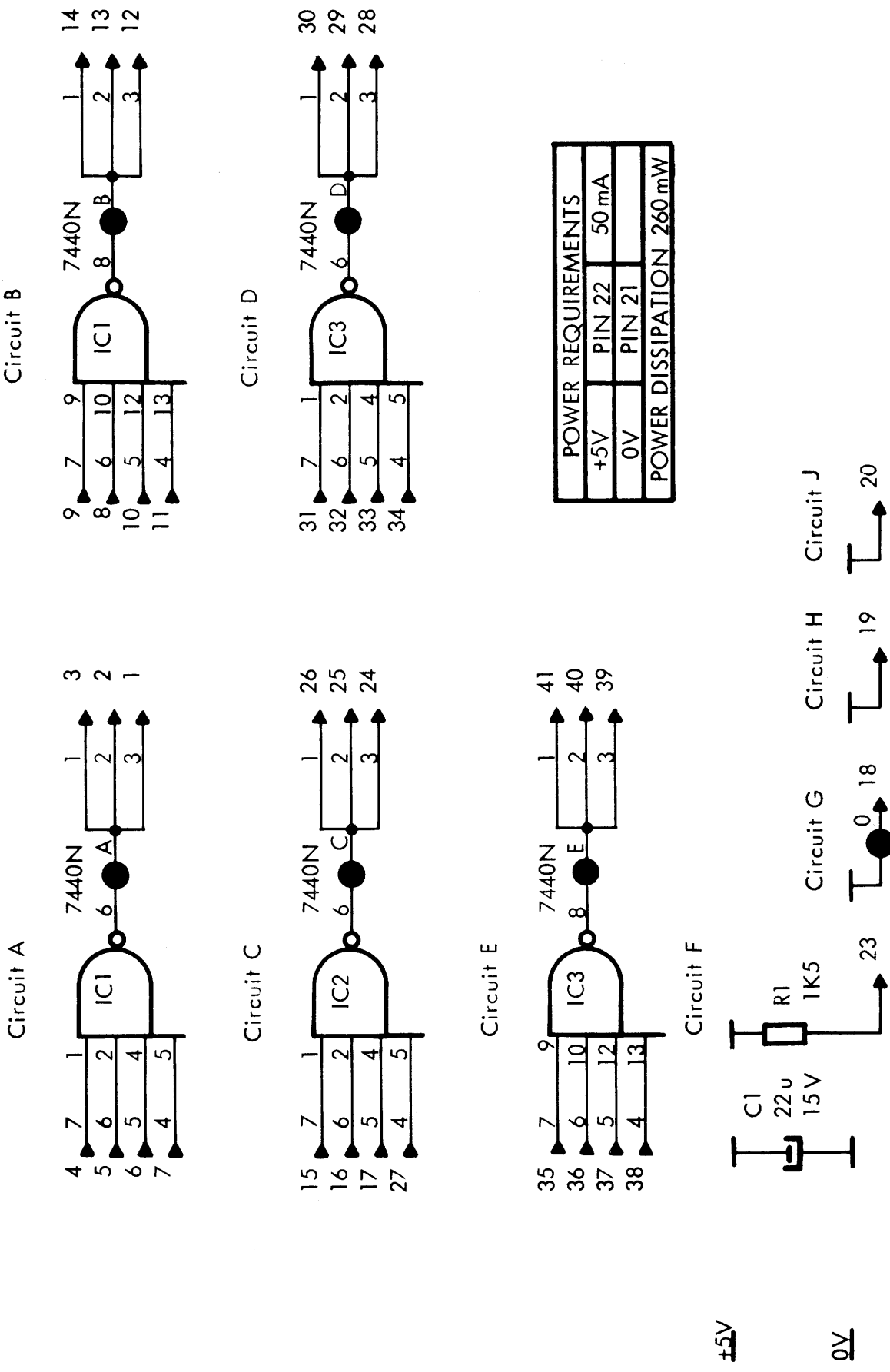

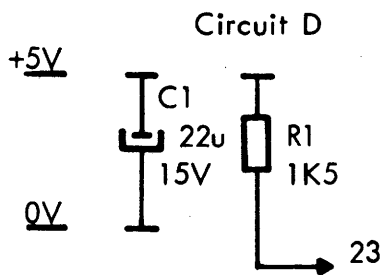
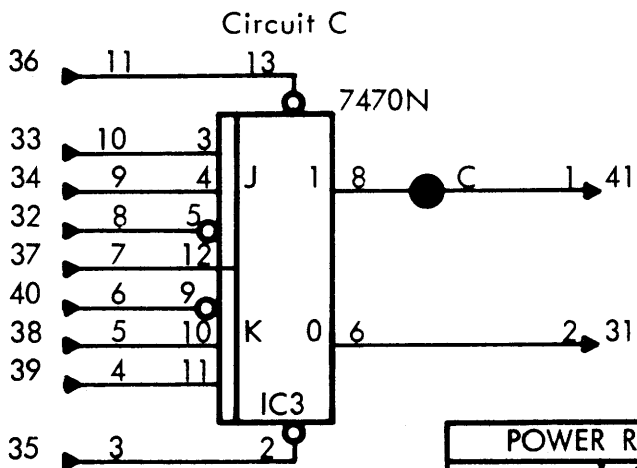
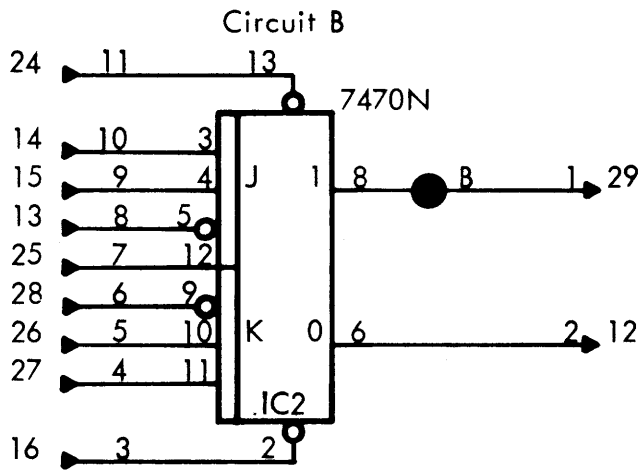
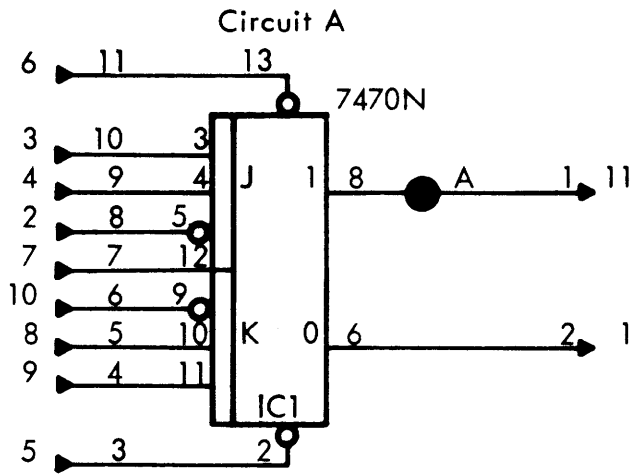

POWER REQUIREMENTS		
+5 V	PIN 22	47 mA
0 V	PIN 21	
POWER DISSIPATION 245 mW		

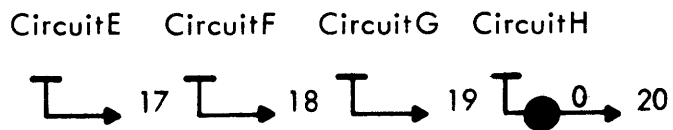

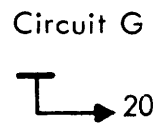
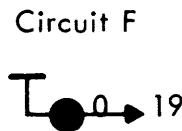
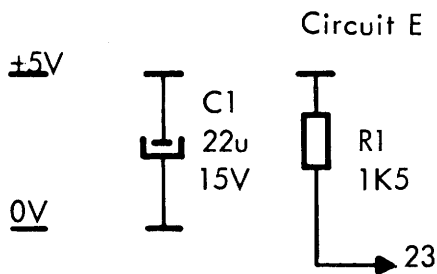
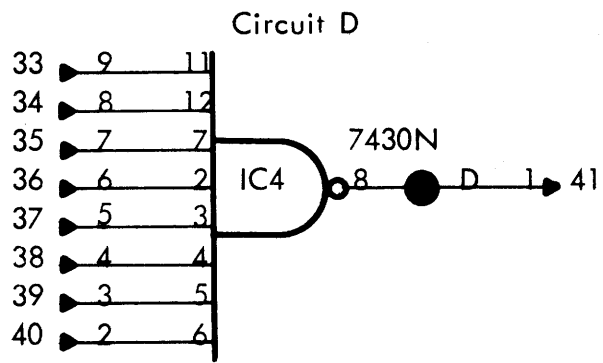
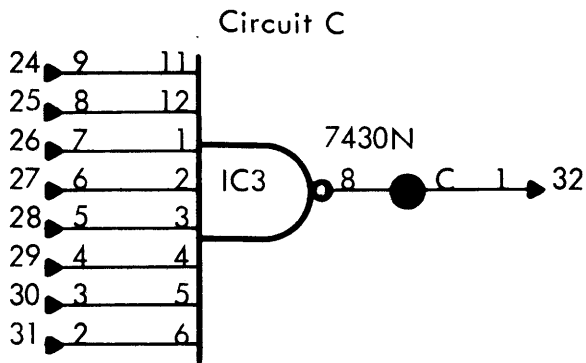
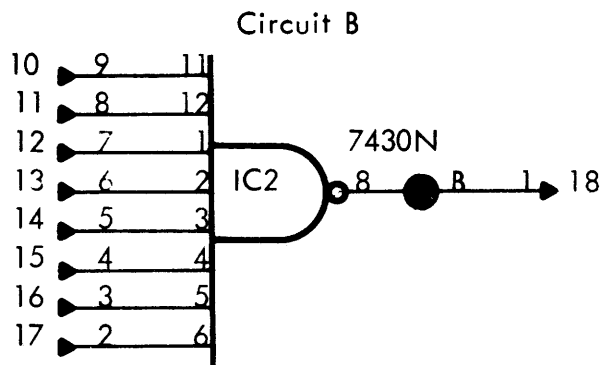
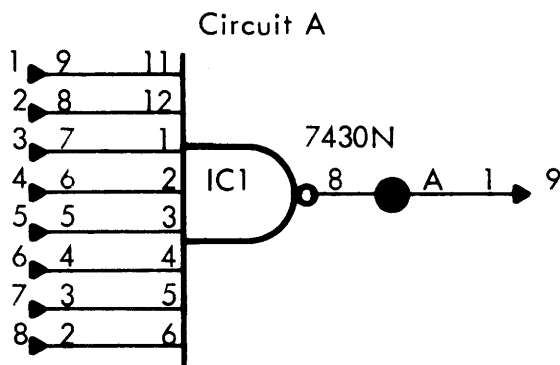

POWER REQUIREMENTS		
+5V	PIN 22	14 mA
0V	PIN 21	
POWER DISSIPATION 70 mW		

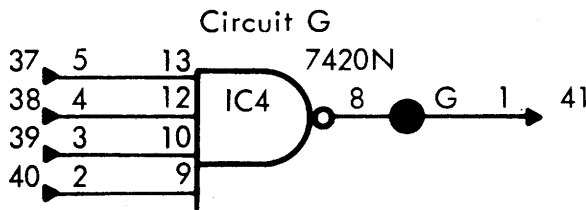
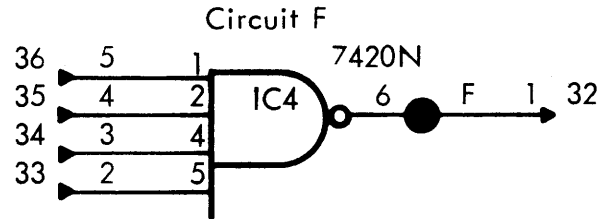
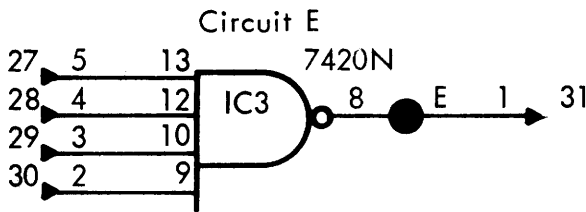
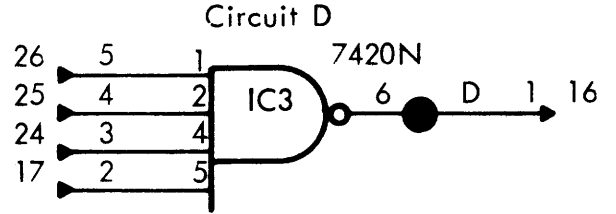
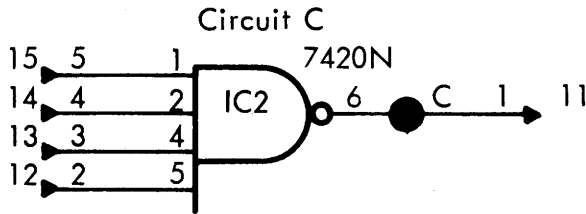
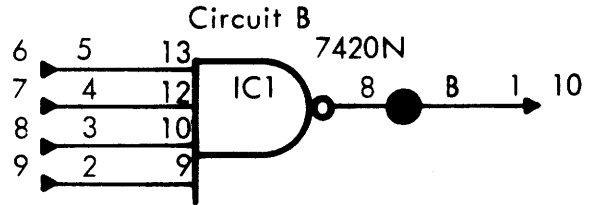
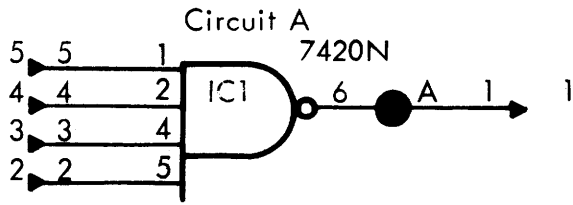

POWER REQUIREMENTS		
+5 V	PIN 22	25 mA
0 V	PIN 21	
POWER DISSIPATION 130mW		

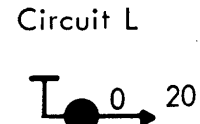
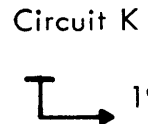
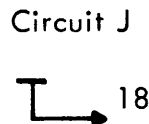
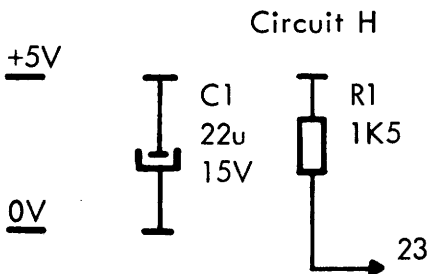

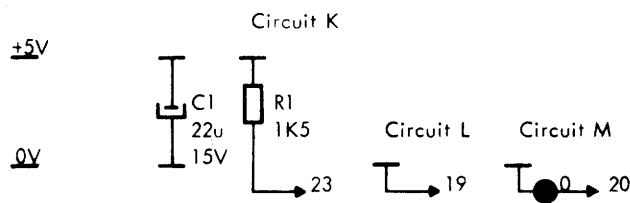
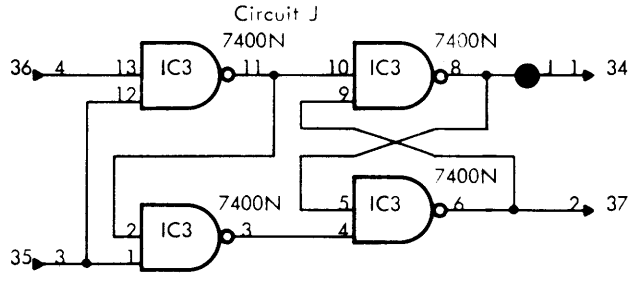
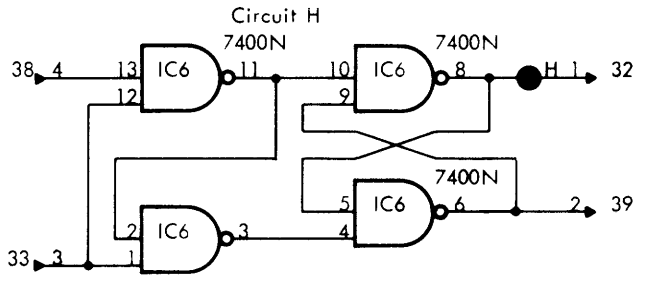
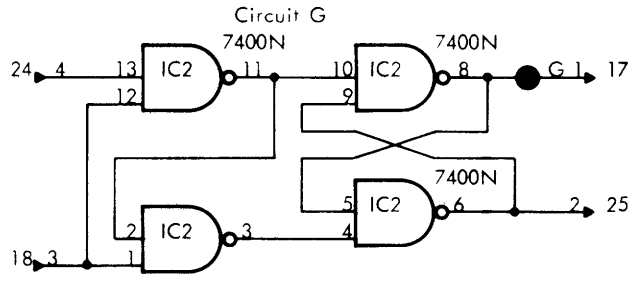
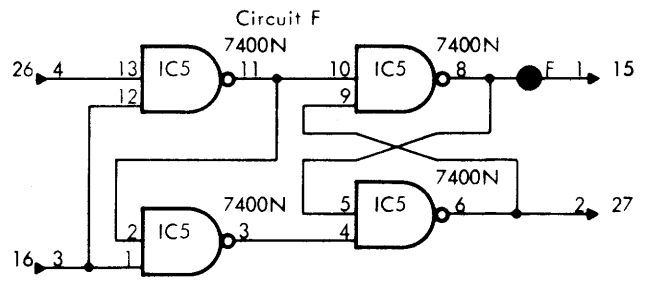
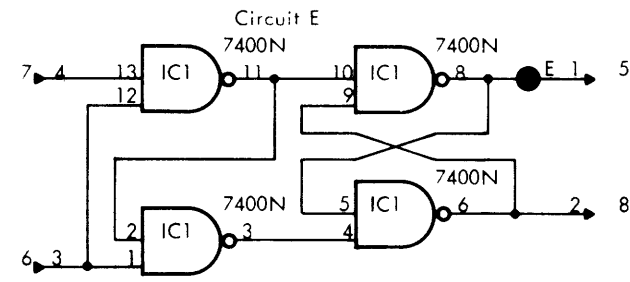
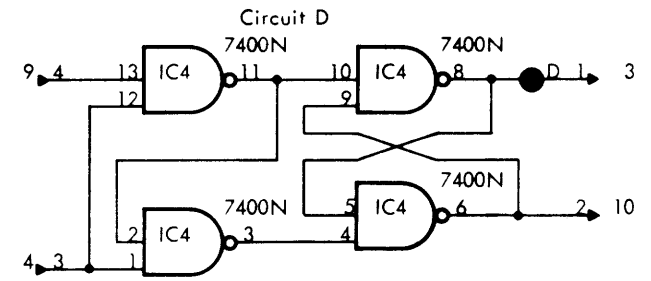
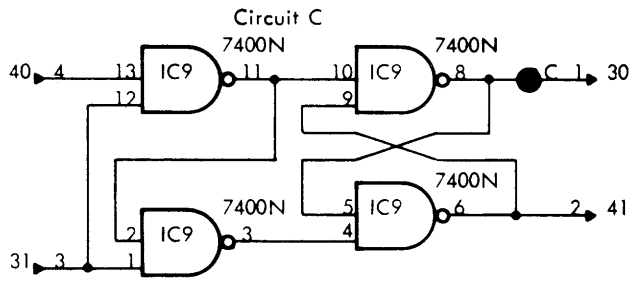
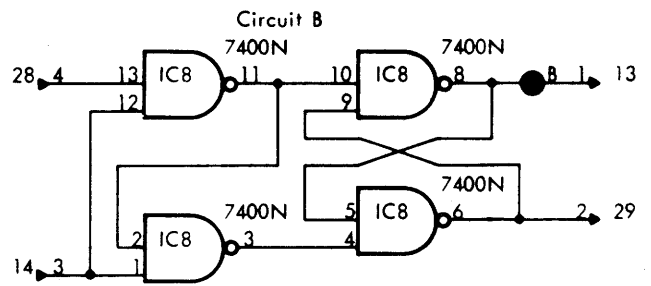
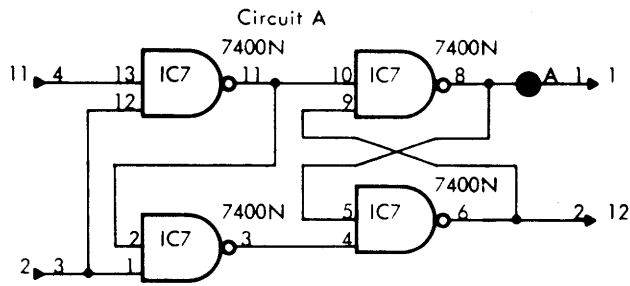

POWER REQUIREMENTS		
+5V	PIN 22	80 mA
0V	PIN 21	
POWER DISSIPATION 420 mW		

CIRCUIT A

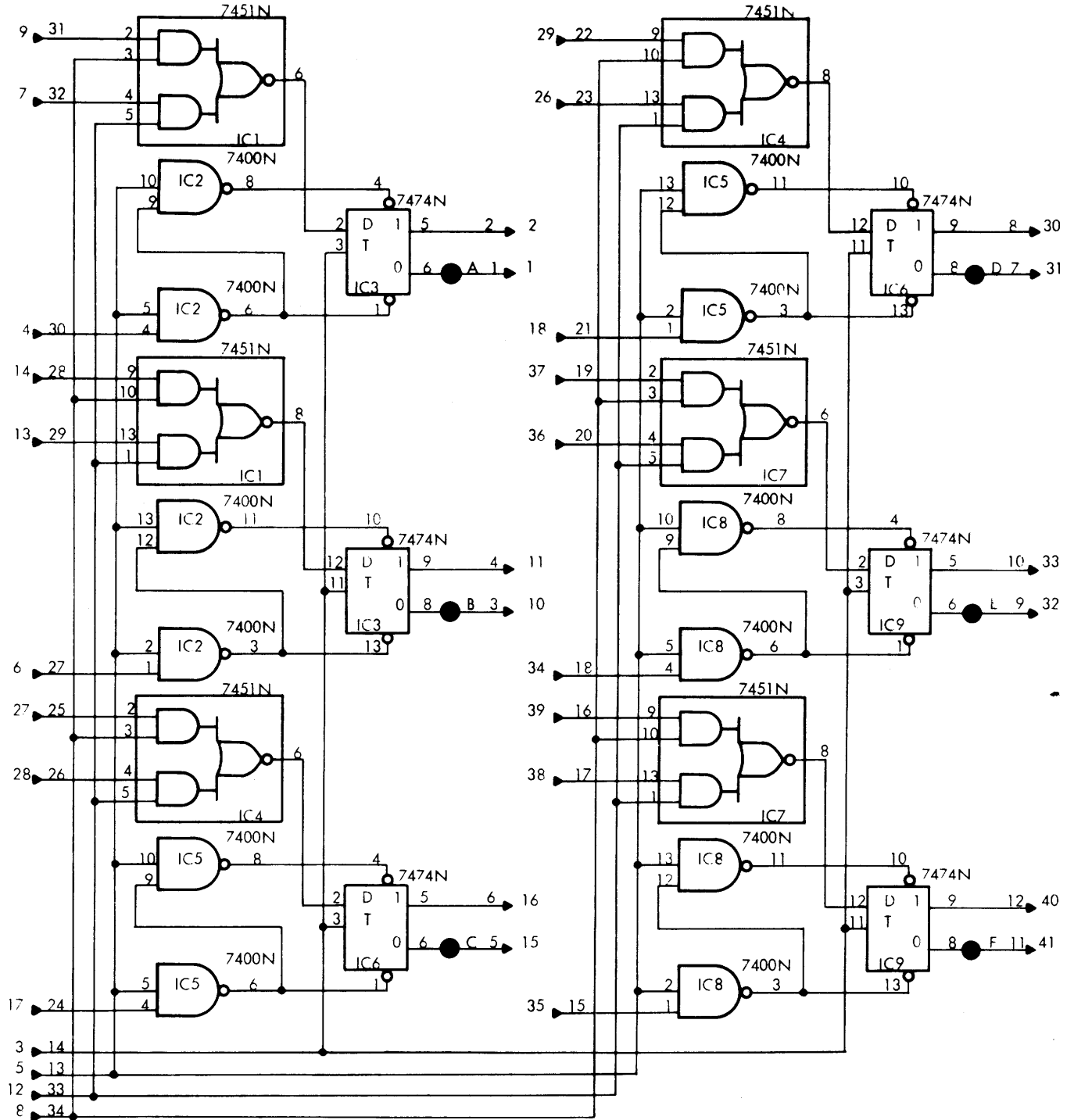

CIRCUIT B

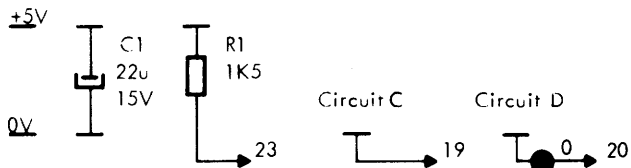

POWER REQUIREMENTS		
+5V	PIN 22	107 mA
0V	PIN 21	
POWER DISSIPATION 565 mW		

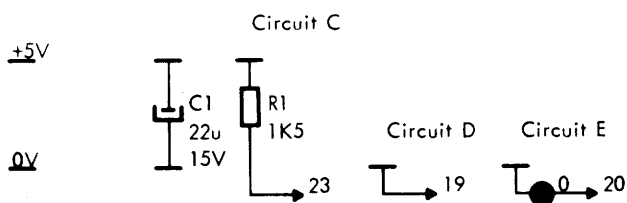
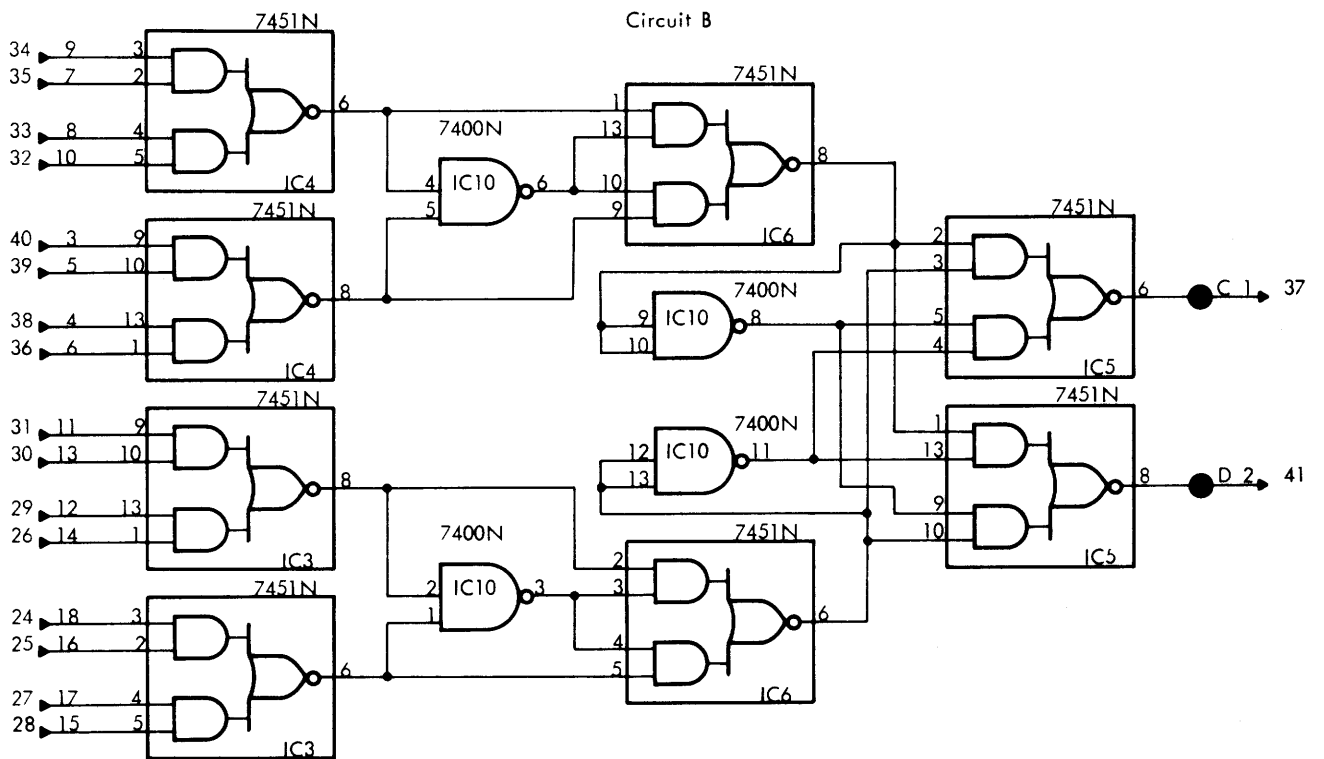
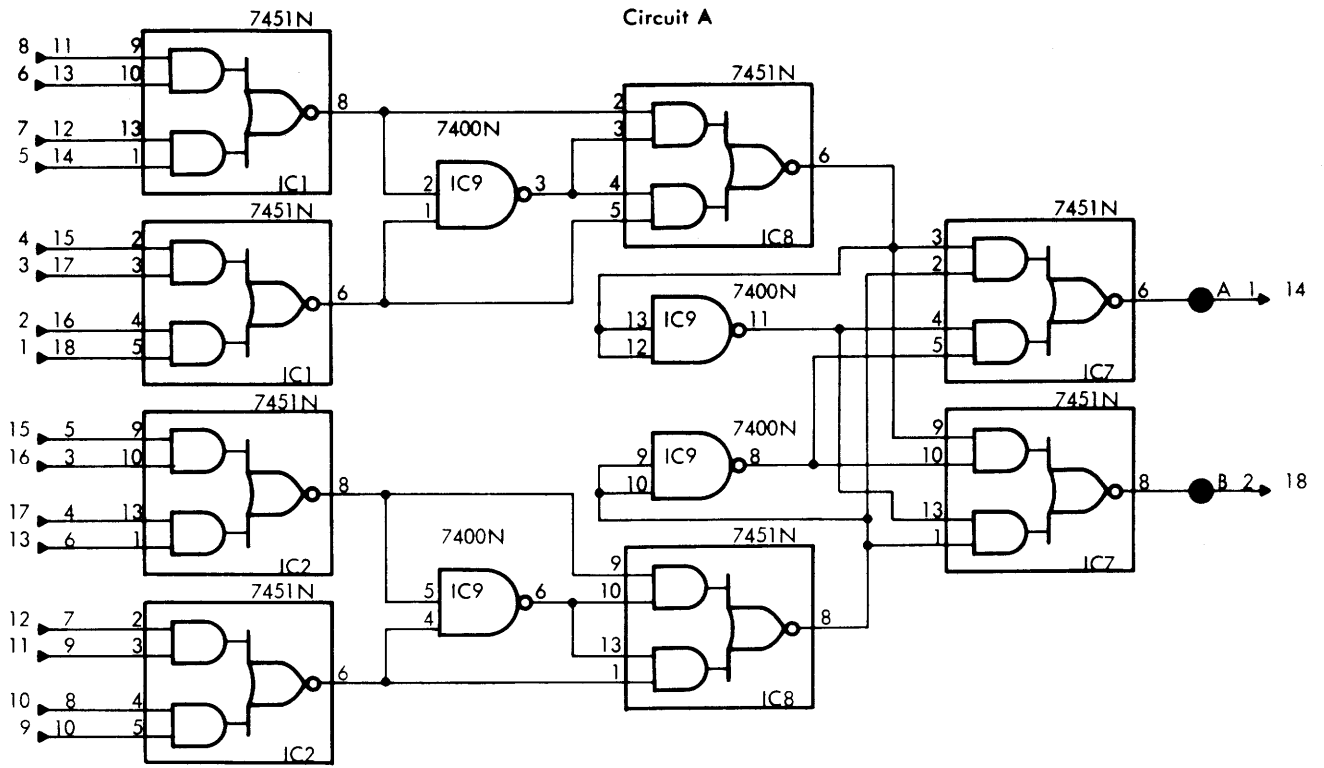

POWER REQUIREMENTS		
+5V	PIN 22	78mA
0V	PIN 21	
POWER DISSIPATION 470mW		

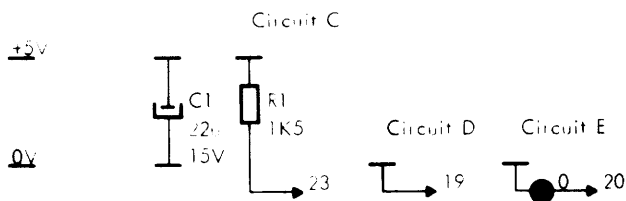
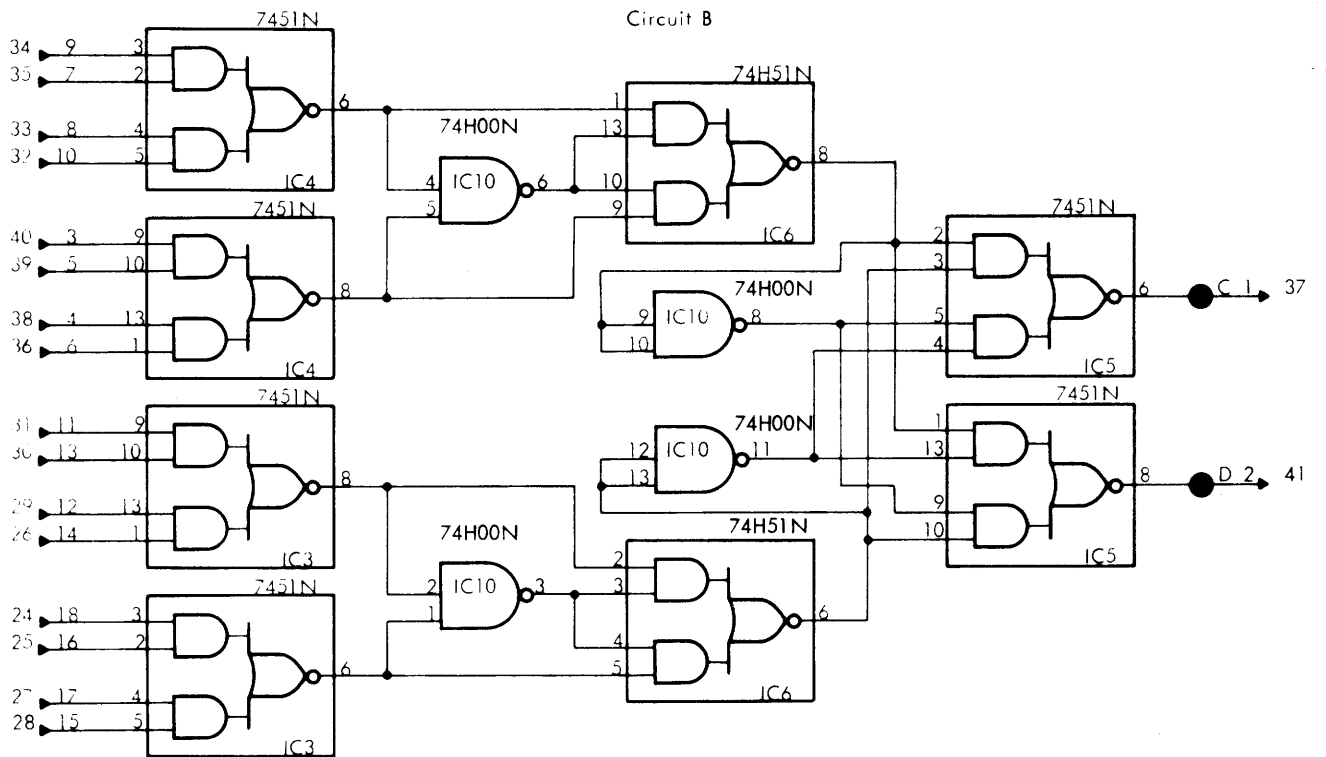
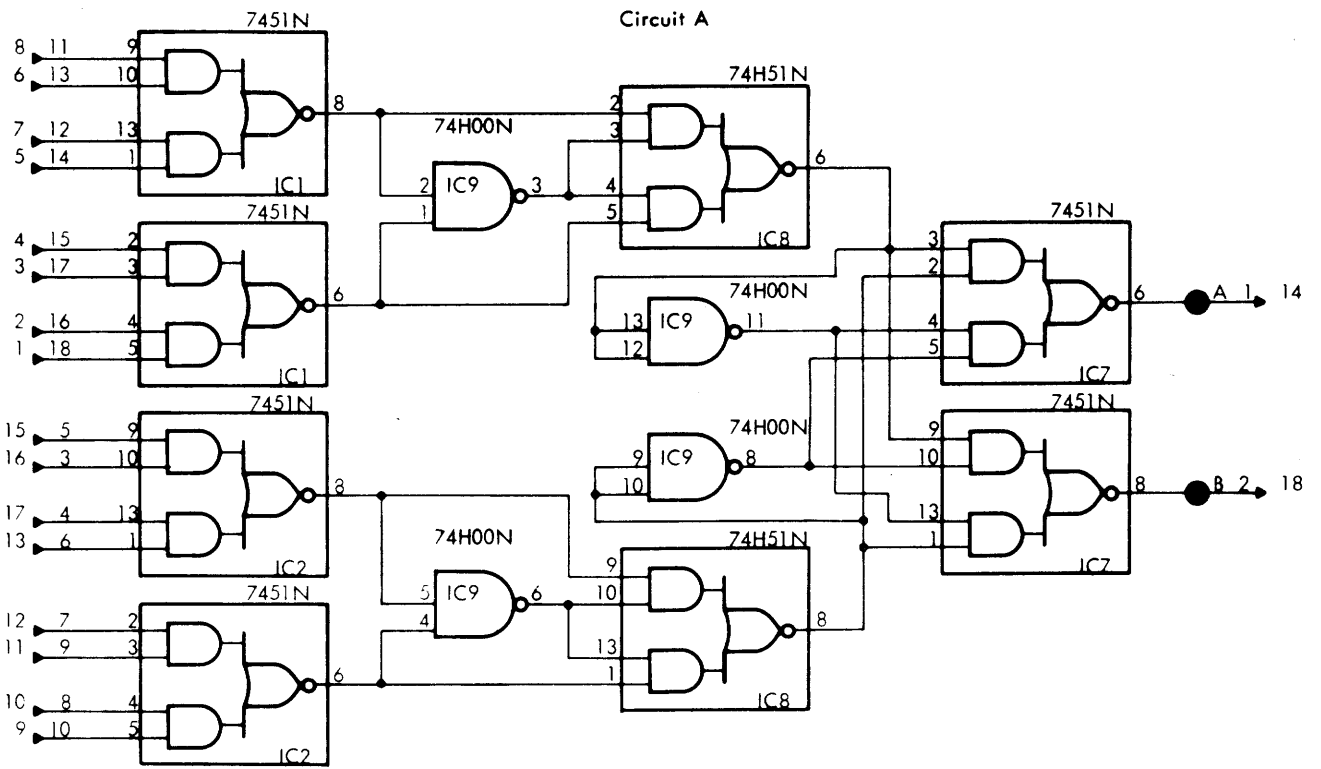

POWER REQUIREMENTS		
+5V	PIN 22	119mA
0V	PIN 21	
POWER DISSIPATION 625mW		

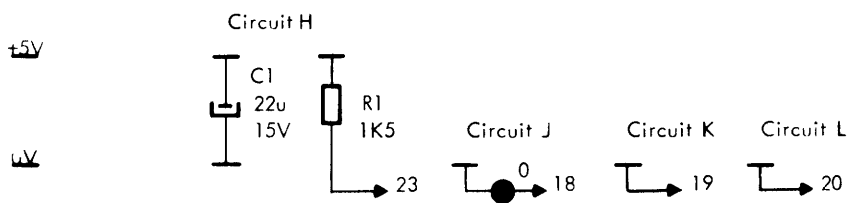
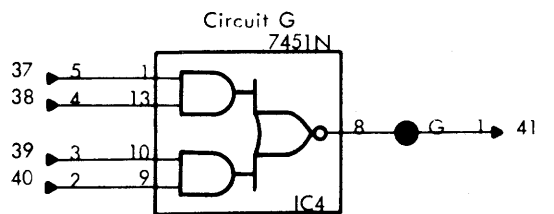
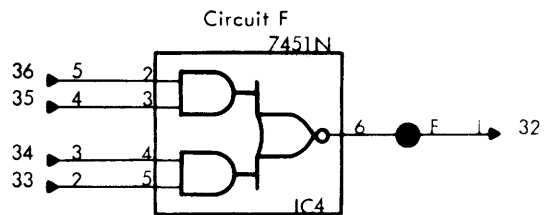
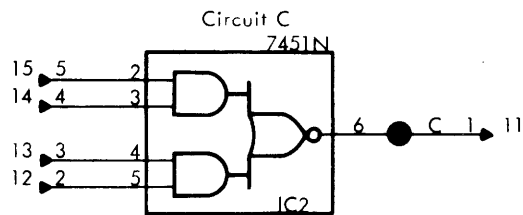
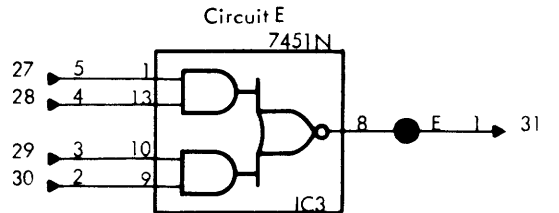
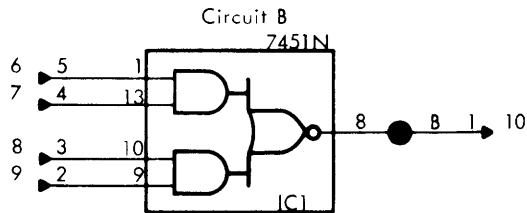
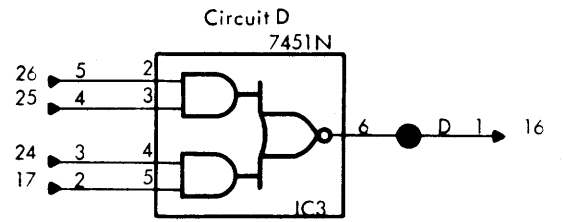
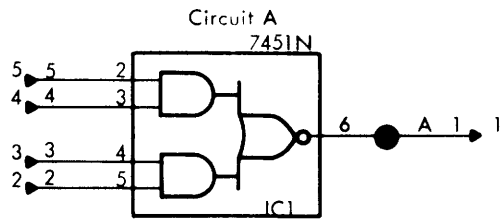

POWER REQUIREMENTS		
+5V	PIN 22	31 mA
0V	PIN 21	
POWER DISSIPATION 165mW		

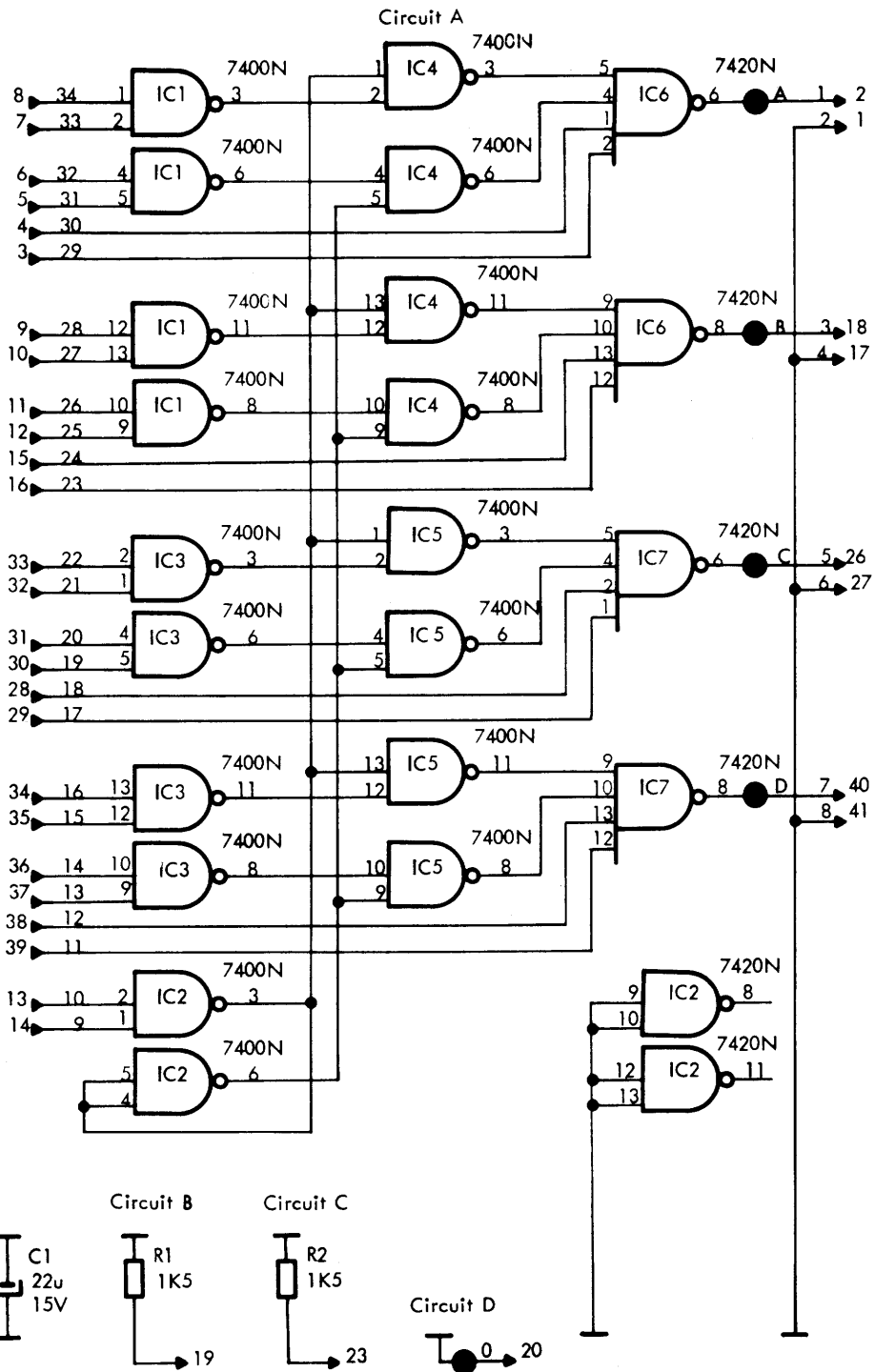

POWER REQUIREMENTS		
+5V	PIN 22	55mA
0V	PIN 21	
POWER DISSIPATION 290mW		

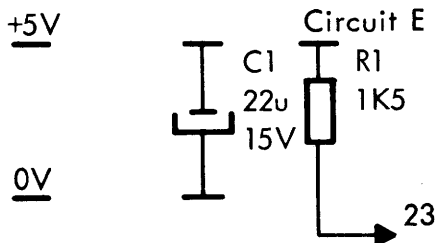
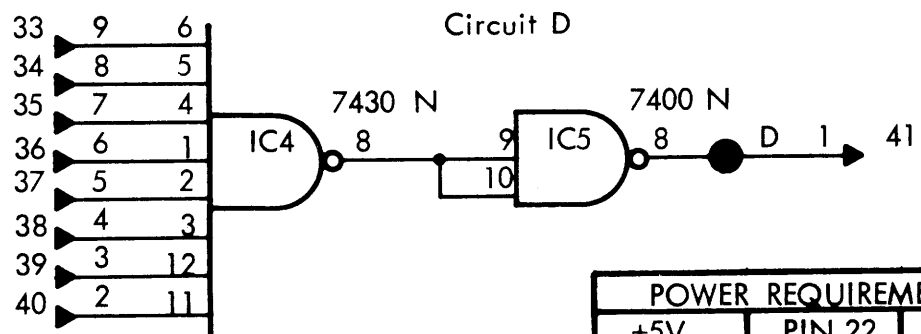
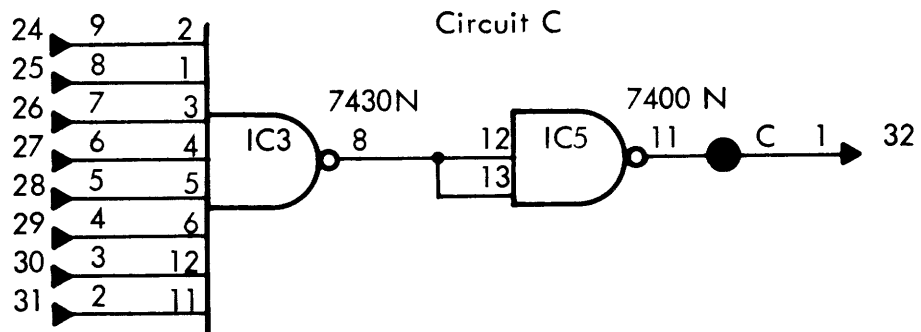
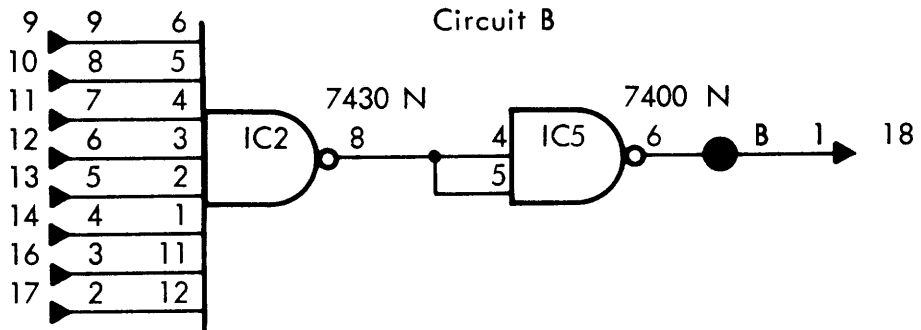
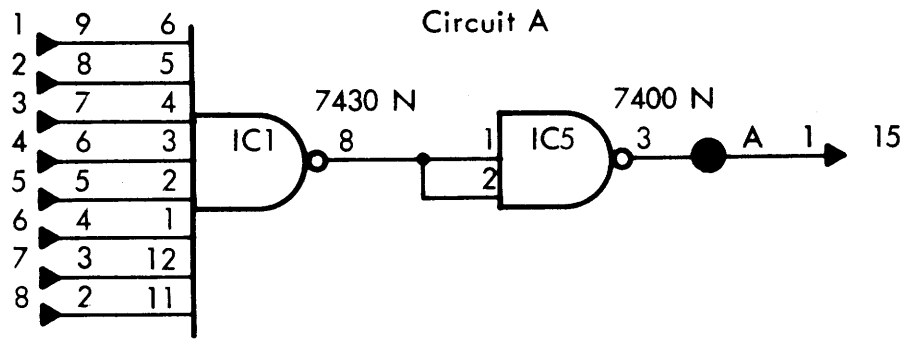

POWER REQUIREMENTS		
+5V	PIN 22	18mA
0V	PIN 21	
POWER DISSIPATION 95 mW		

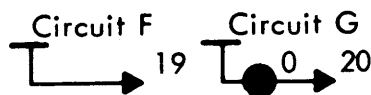

Circuit A

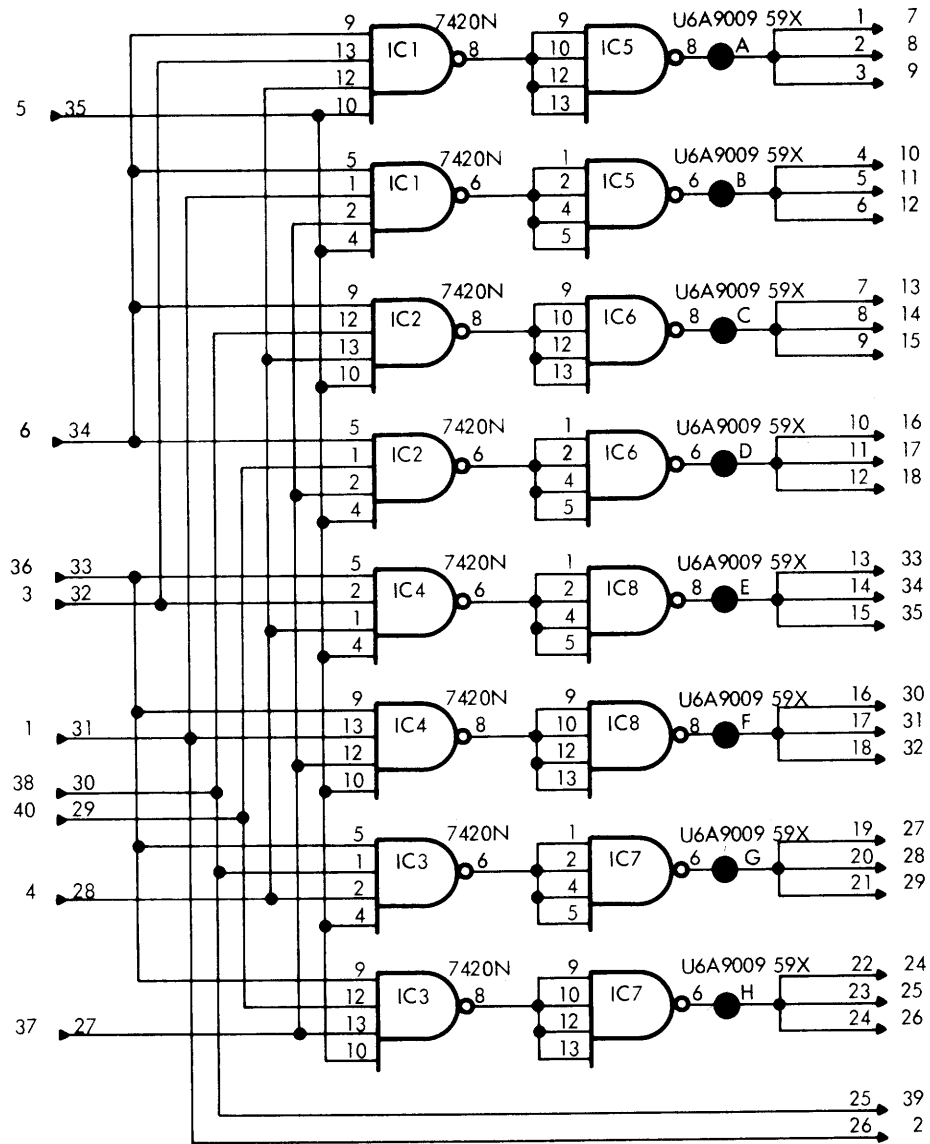

Circuit B

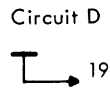
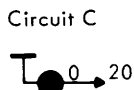
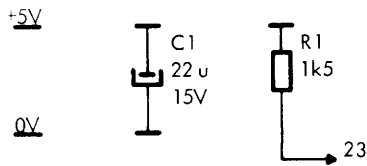

POWER REQUIREMENTS		
+5V	PIN 22	85 mA
0V	PIN 21	
POWER DISSIPATION 445 mW		

Circuit A

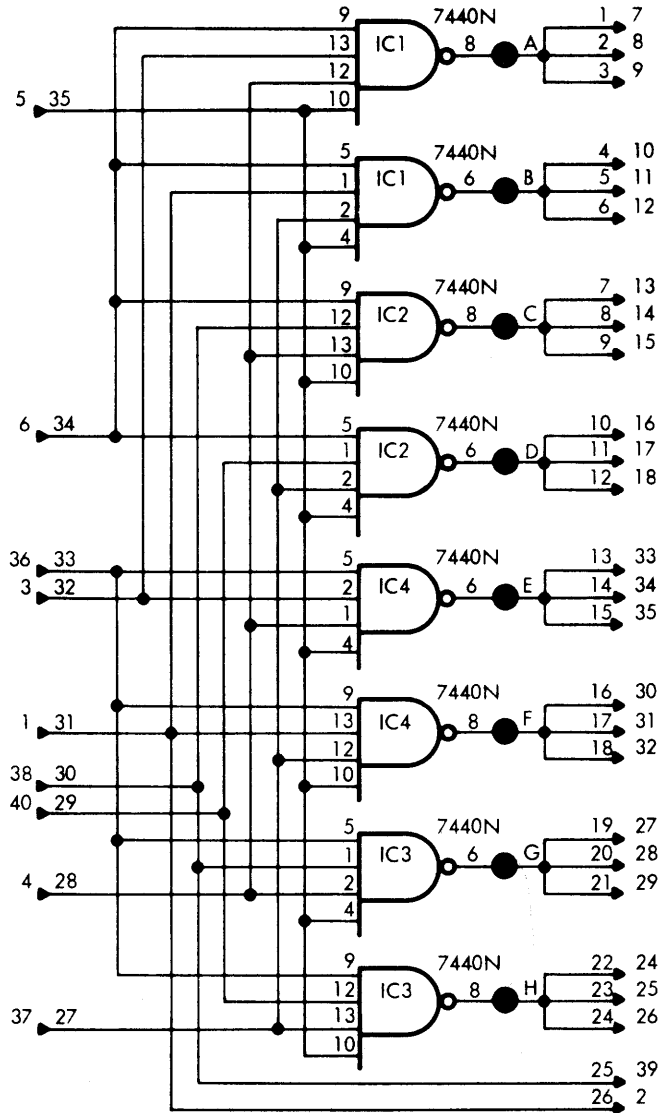

Circuit B

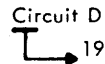
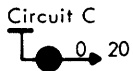
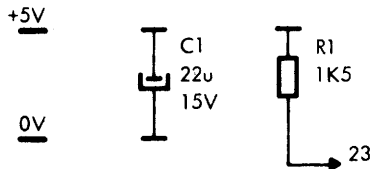

POWER REQUIREMENTS		
+5V	PIN 22	25mA
0V	PIN 21	
POWER DISSIPATION 135mW		

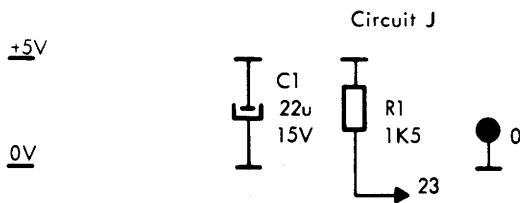
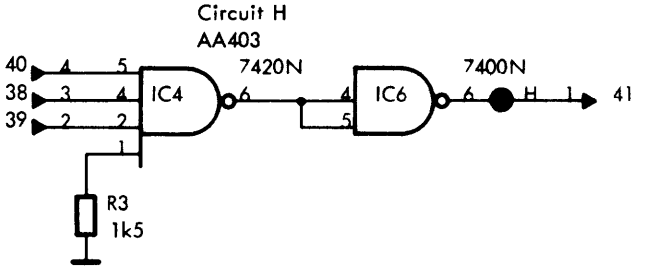
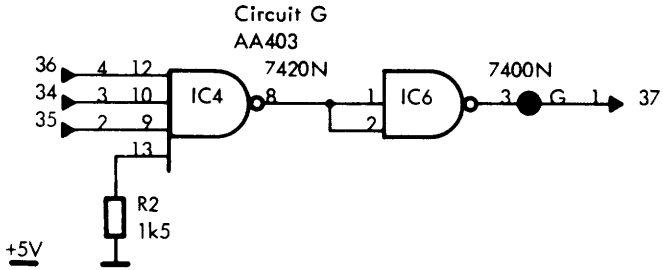
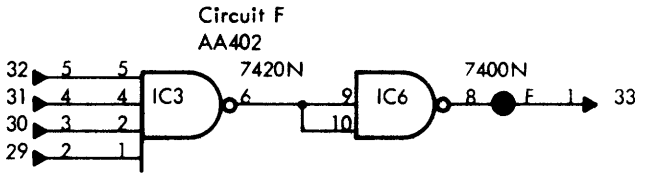
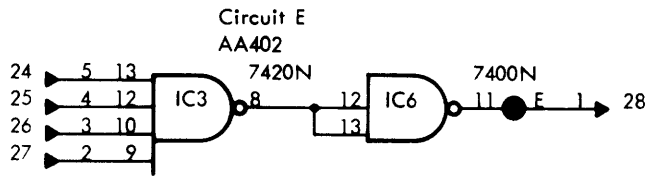
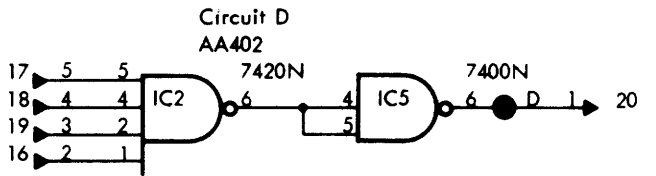
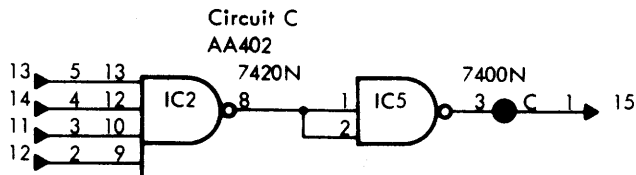
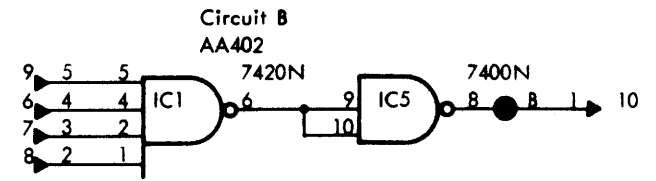
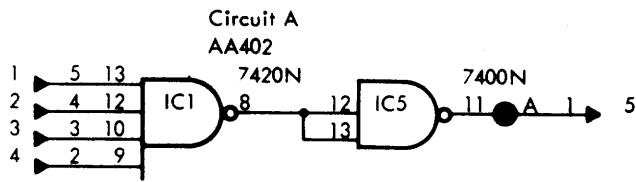

POWER REQUIREMENTS		
+5V	PIN 22	36 mA
0V	PIN 21	
POWER DISSIPATION 190 mW		

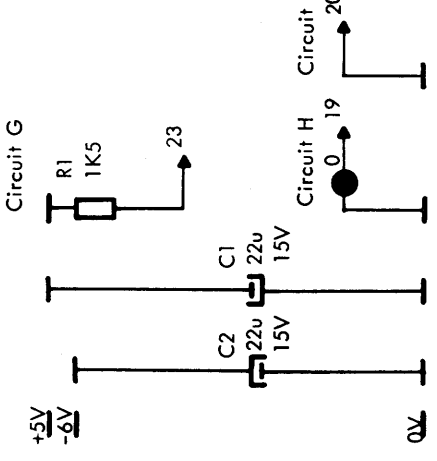
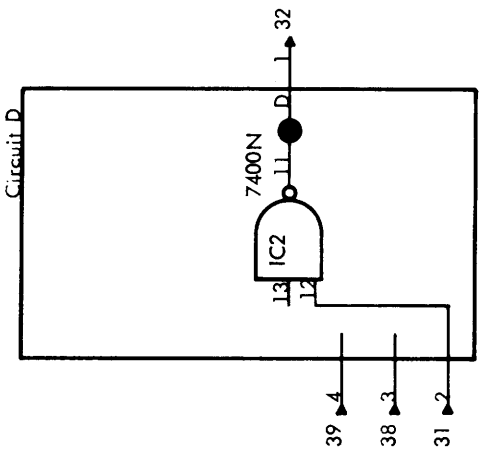
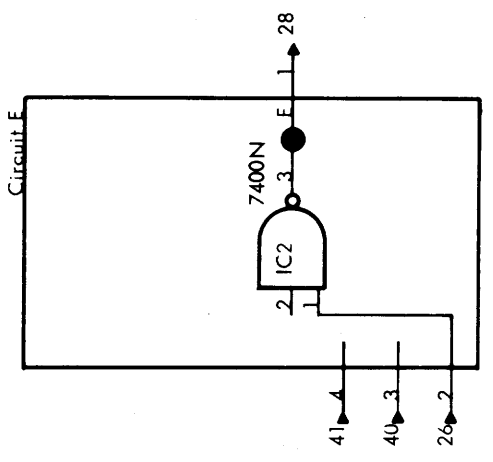
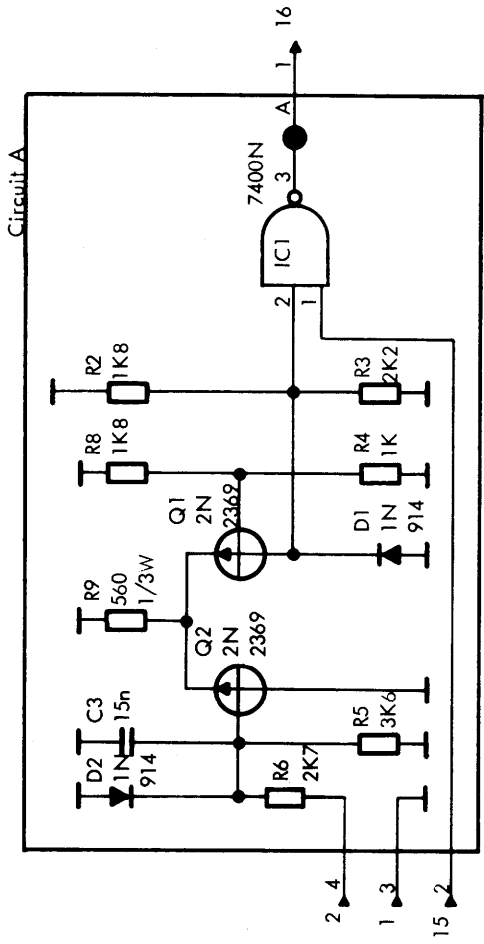
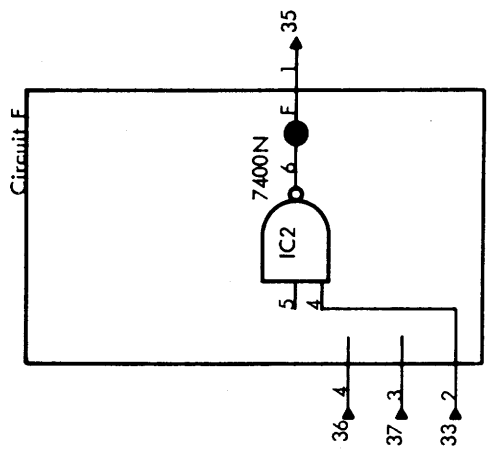
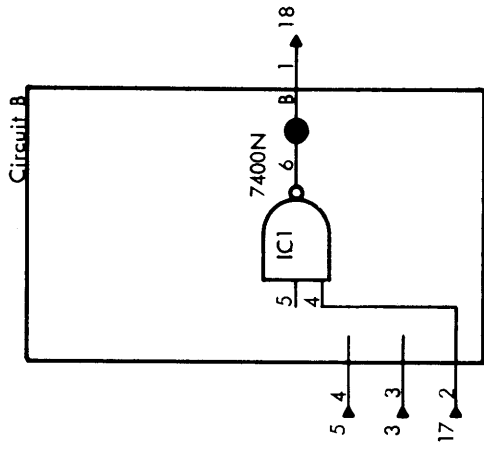

POWER REQUIREMENTS	
+5V	PIN 22 28 mA
0V	PIN 21
-6V	PIN 4 64 mA
POWER DISSIPATION 550 mW	

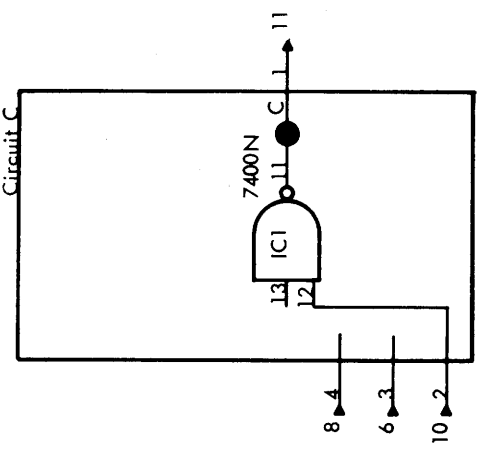

Circuit A

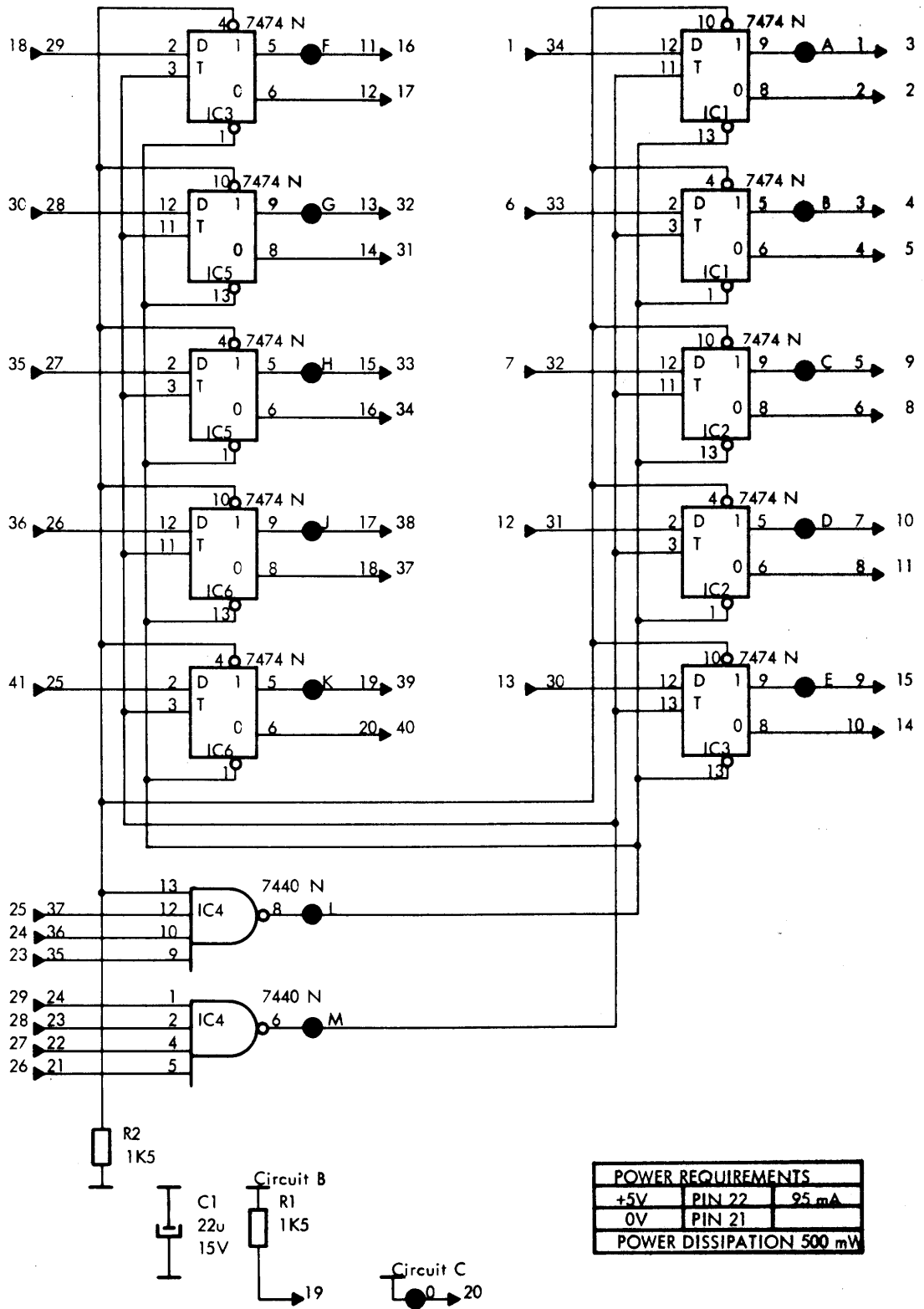

Circuit A
1AA404

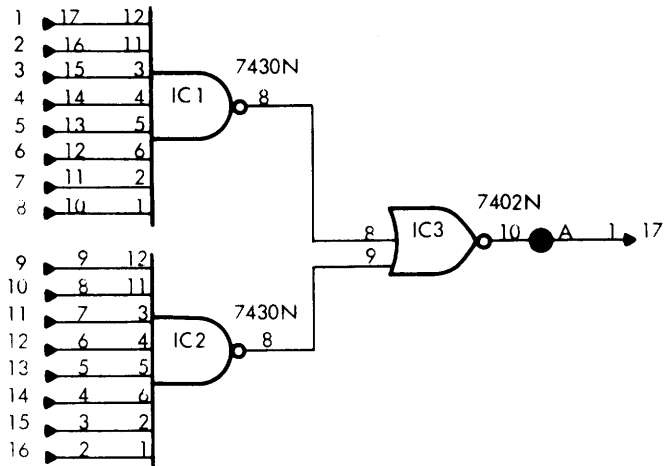

Circuit B
1AA404

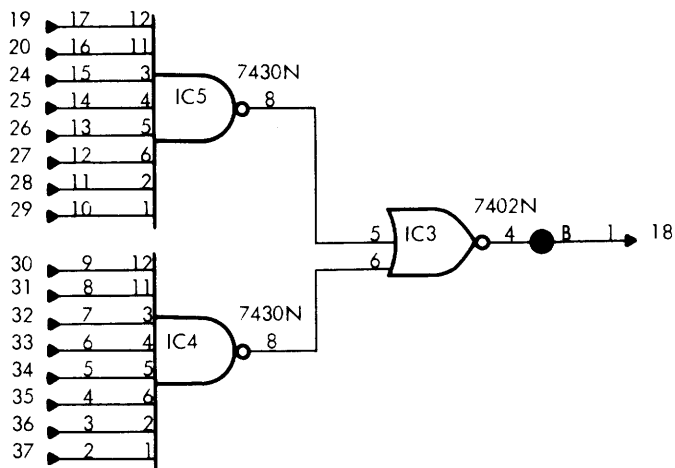

Circuit C
1AA403

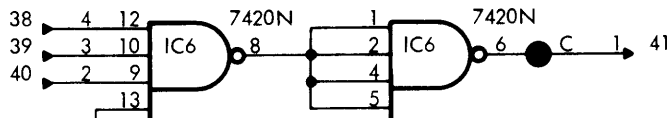

+5V

0V

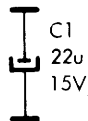

Circuit D

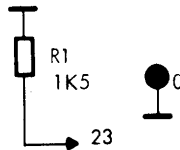

POWER REQUIREMENTS		
+5V	PIN 22	27 mA
0V	PIN 21	
POWER DISSIPATION 140 mW		

Circuit A

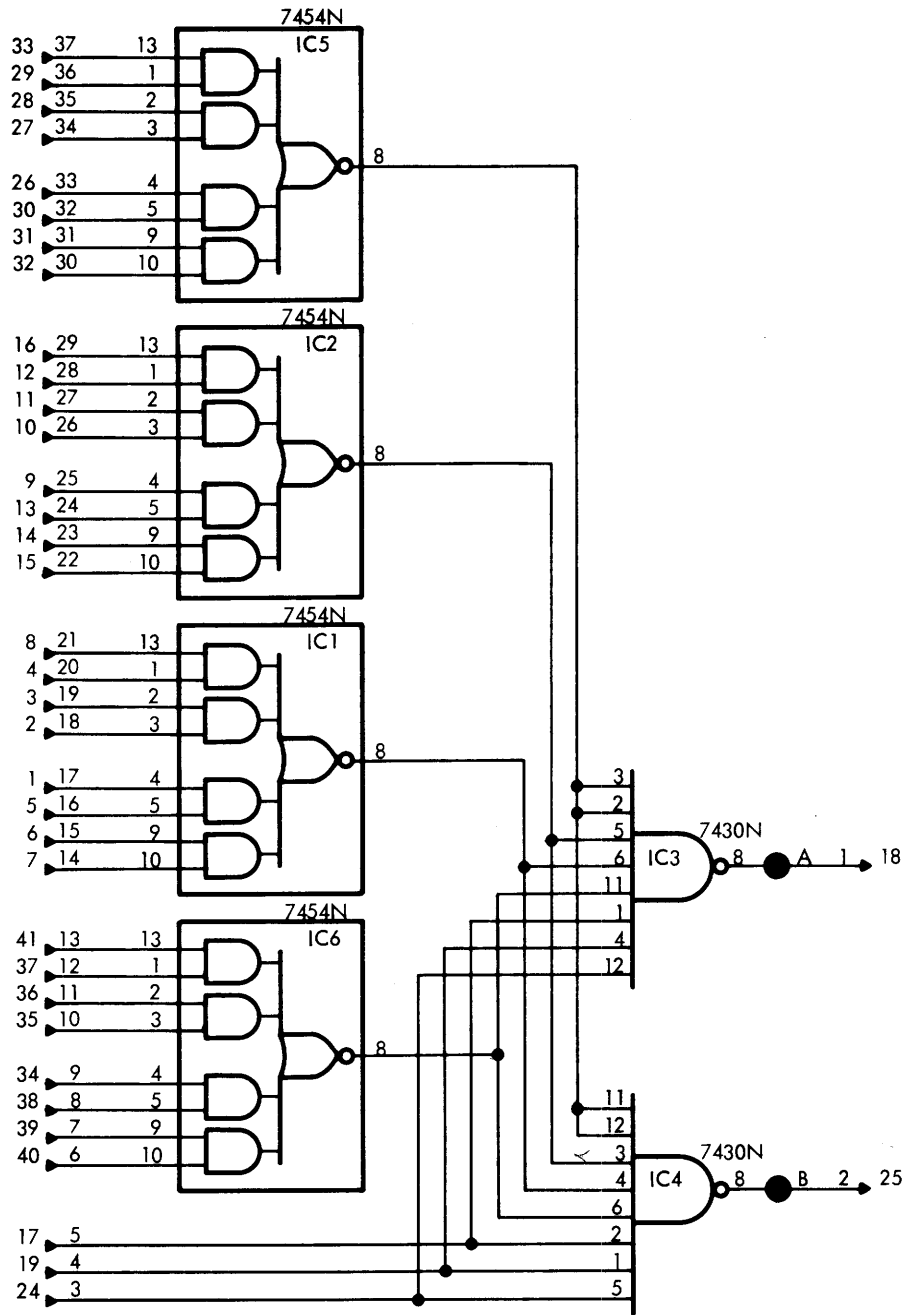

Circuit B

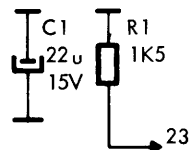

Circuit C

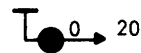

+5V

0V

POWER REQUIREMENTS		
+5V	PIN 22	23 mA
0V	PIN 21	
POWER DISSIPATION 120 mW		

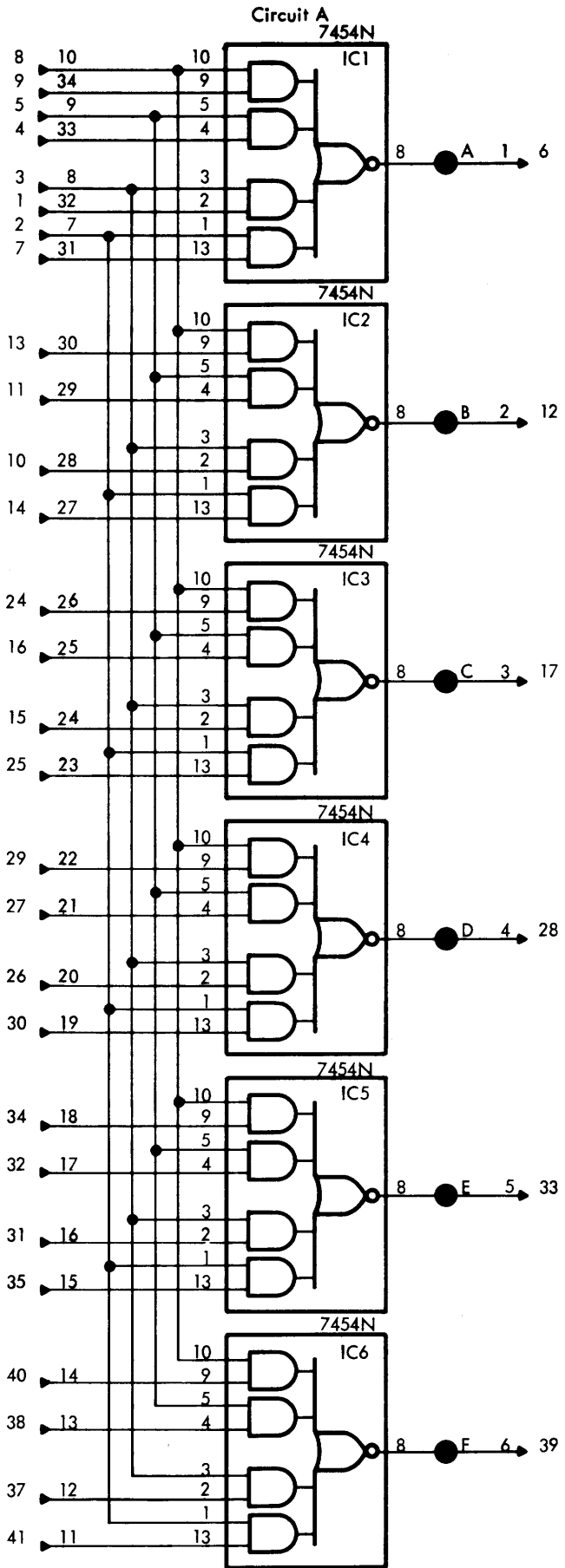

+5V
0V

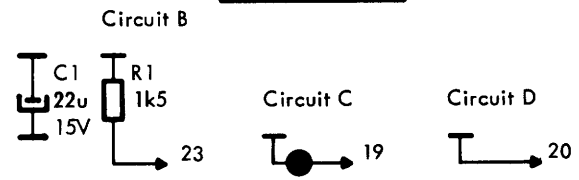

POWER REQUIREMENTS		
+5V	PIN 22	
0V	PIN 21	
POWER DISSIPATION		

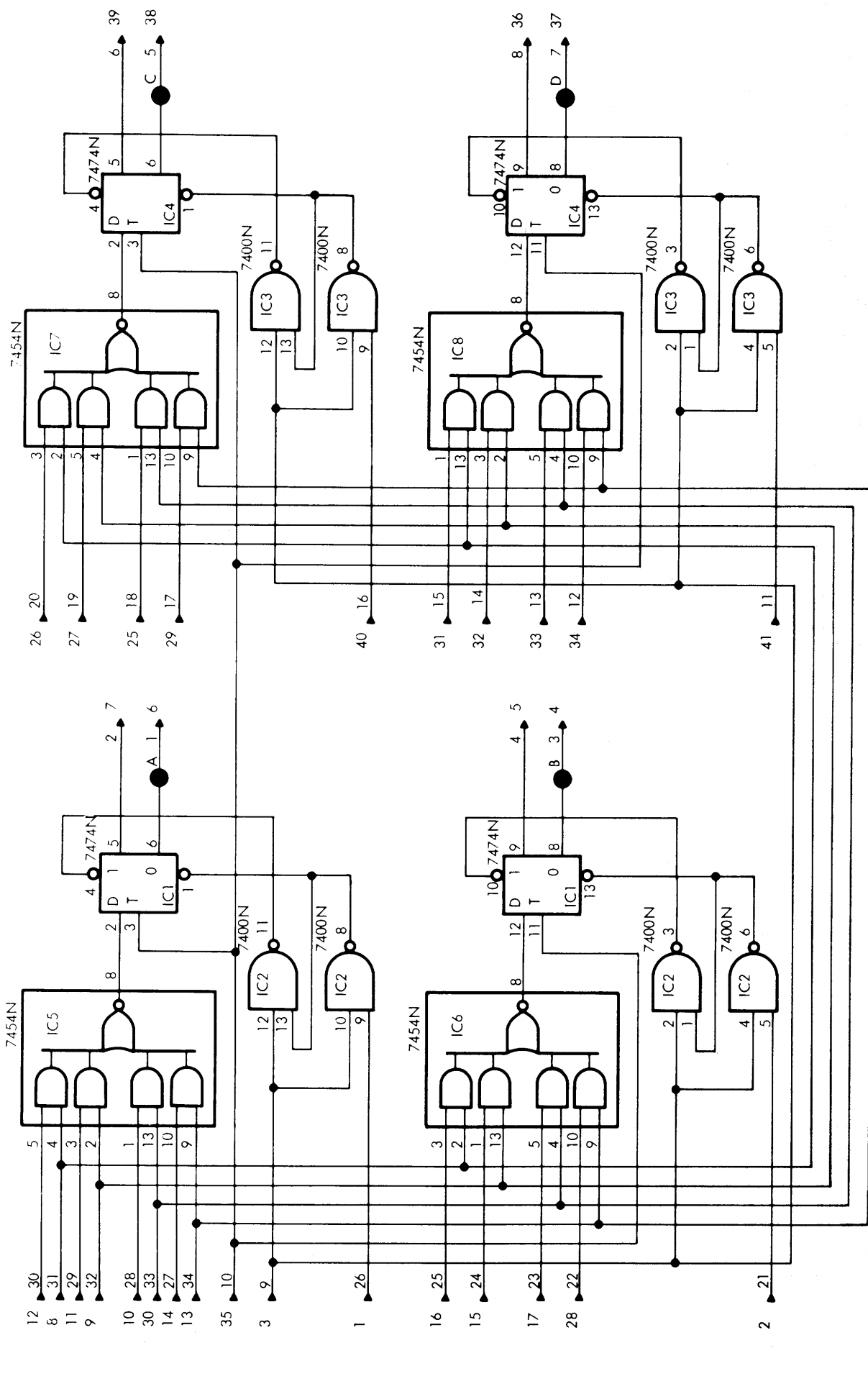

POWER REQUIREMENTS	
+5V	PIN 22 72mA
0V	PIN 21
POWER DISSIPATION 375mW	

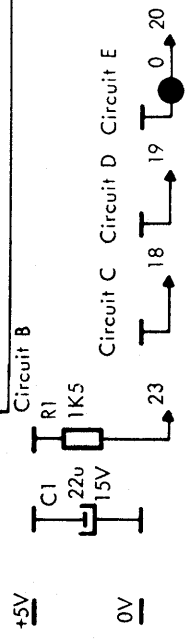

+12V
+5V

+12V
+5V

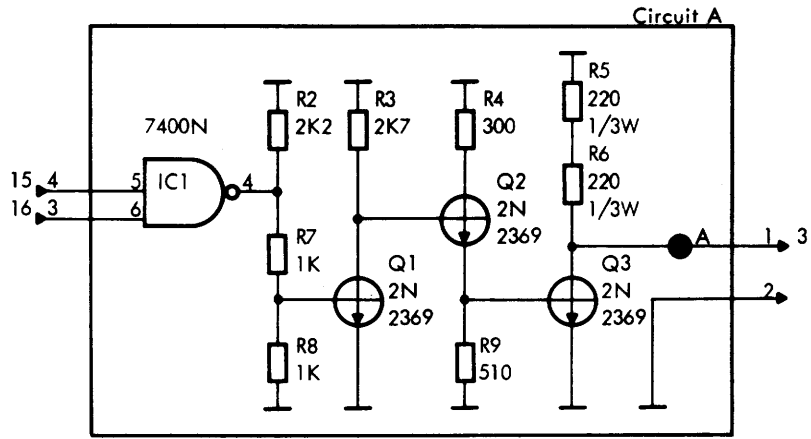

0V

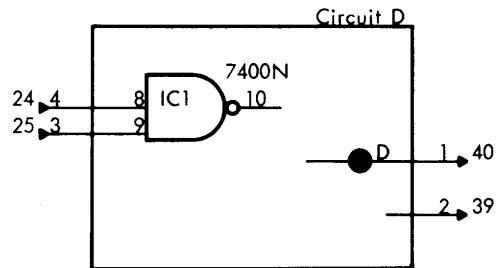
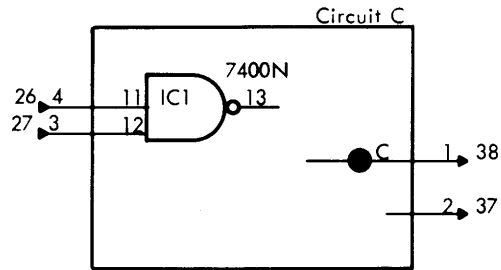
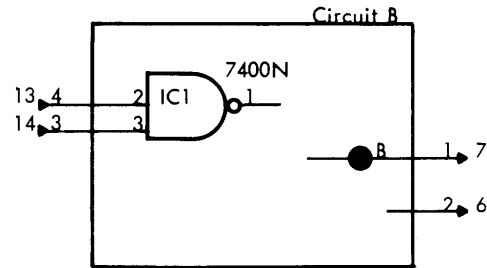

+12V
+5V

+12V
+5V

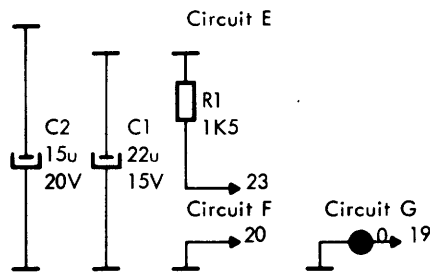

POWER REQUIREMENTS		
+ 12V	PIN 1	115 mA
+ 5V	PIN 22	88 mA
0V	PIN 21	
POWER DISSIPATION 1910 mW		

0V

+12V
+5V

0V

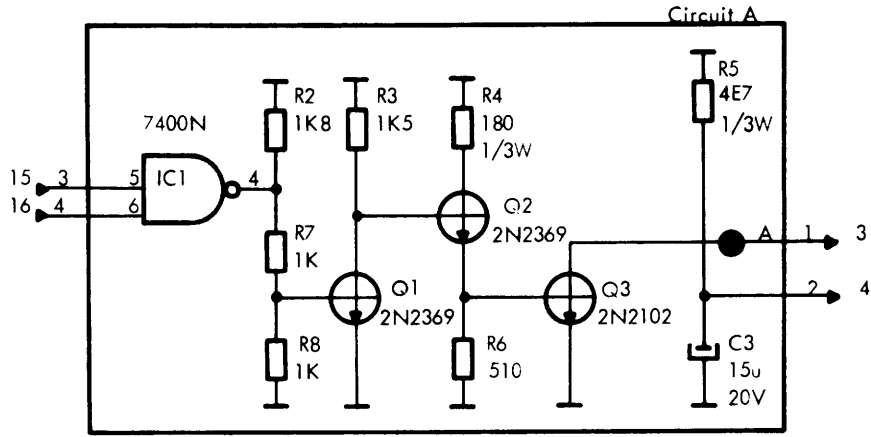

+12V
+5V

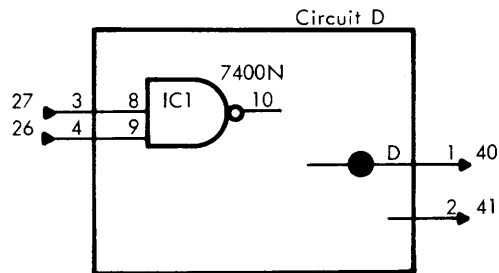
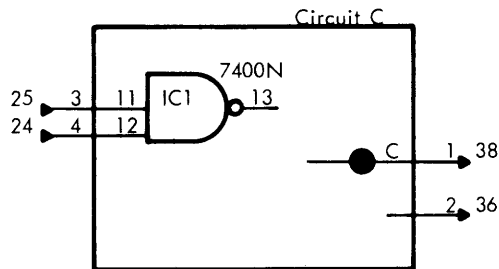
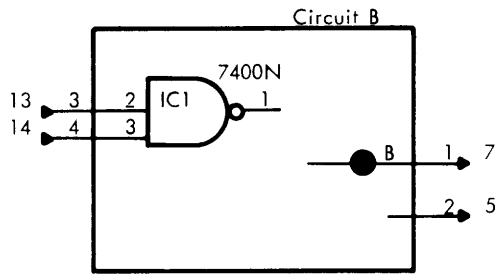

+12V
+5V

0V

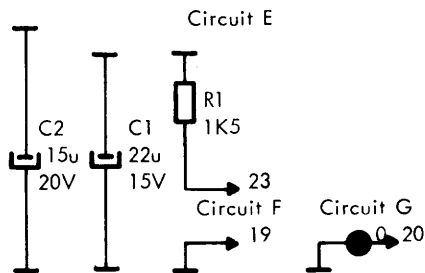

+12V
+5V

POWER REQUIREMENTS		
+12V	PIN 1	65mA / LAMP
+ 5V	PIN 22	132mA
0V	PIN 21	
POWER DISSIPATION 695mW		

Lamp type: CM 330, 14V/80mA or equivalent

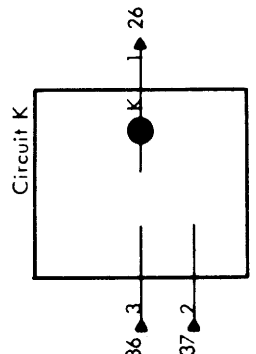
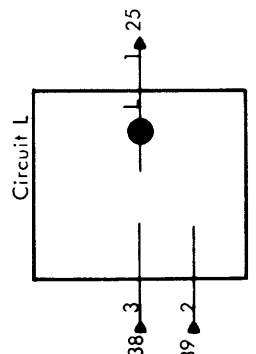
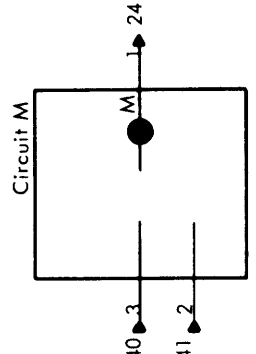
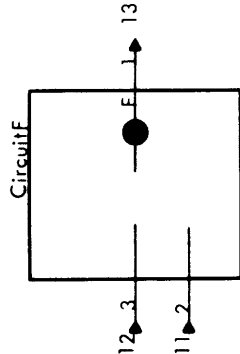
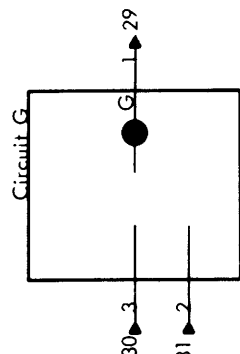
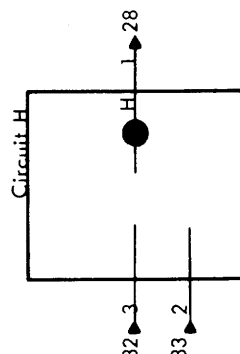
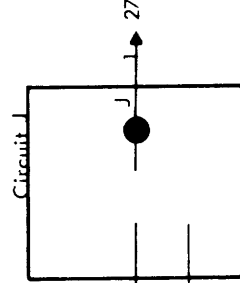
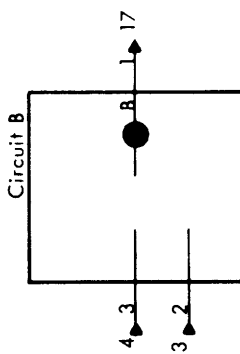
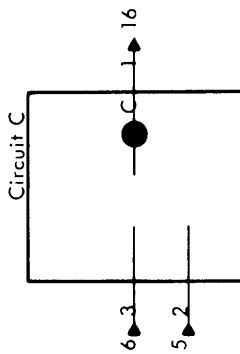
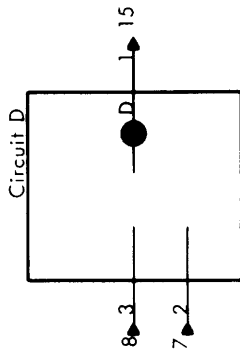
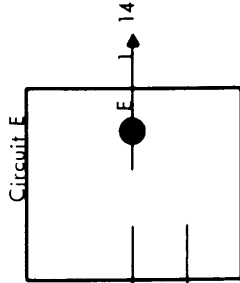
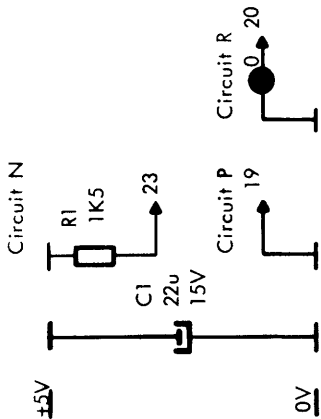
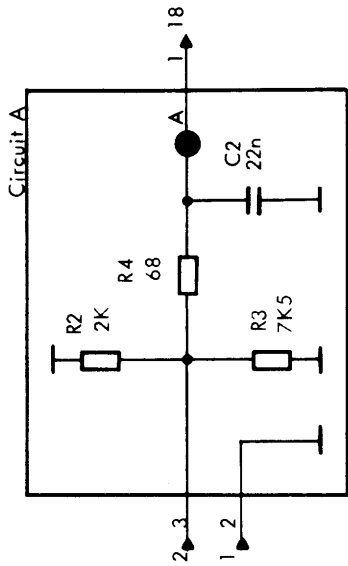

POWER REQUIREMENTS		
+ 5V	PIN 22	32 mA
0V	PIN 21	
POWER DISSIPATION 170 mW		

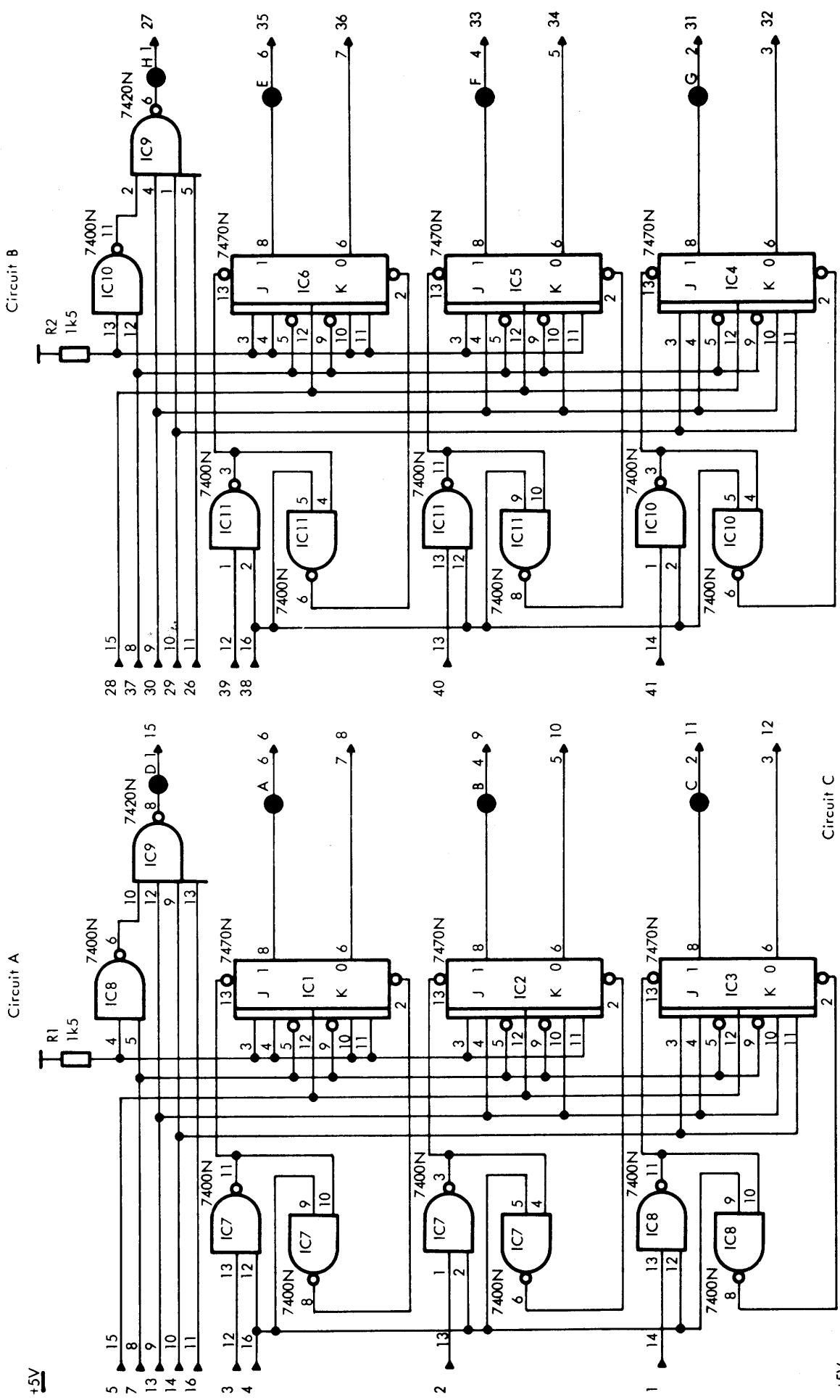

POWER REQUIREMENTS		
+5V	PIN 22	124mA
0V	PIN 21	
POWER DISSIPATION 650mW		

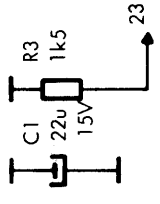

Circuit A

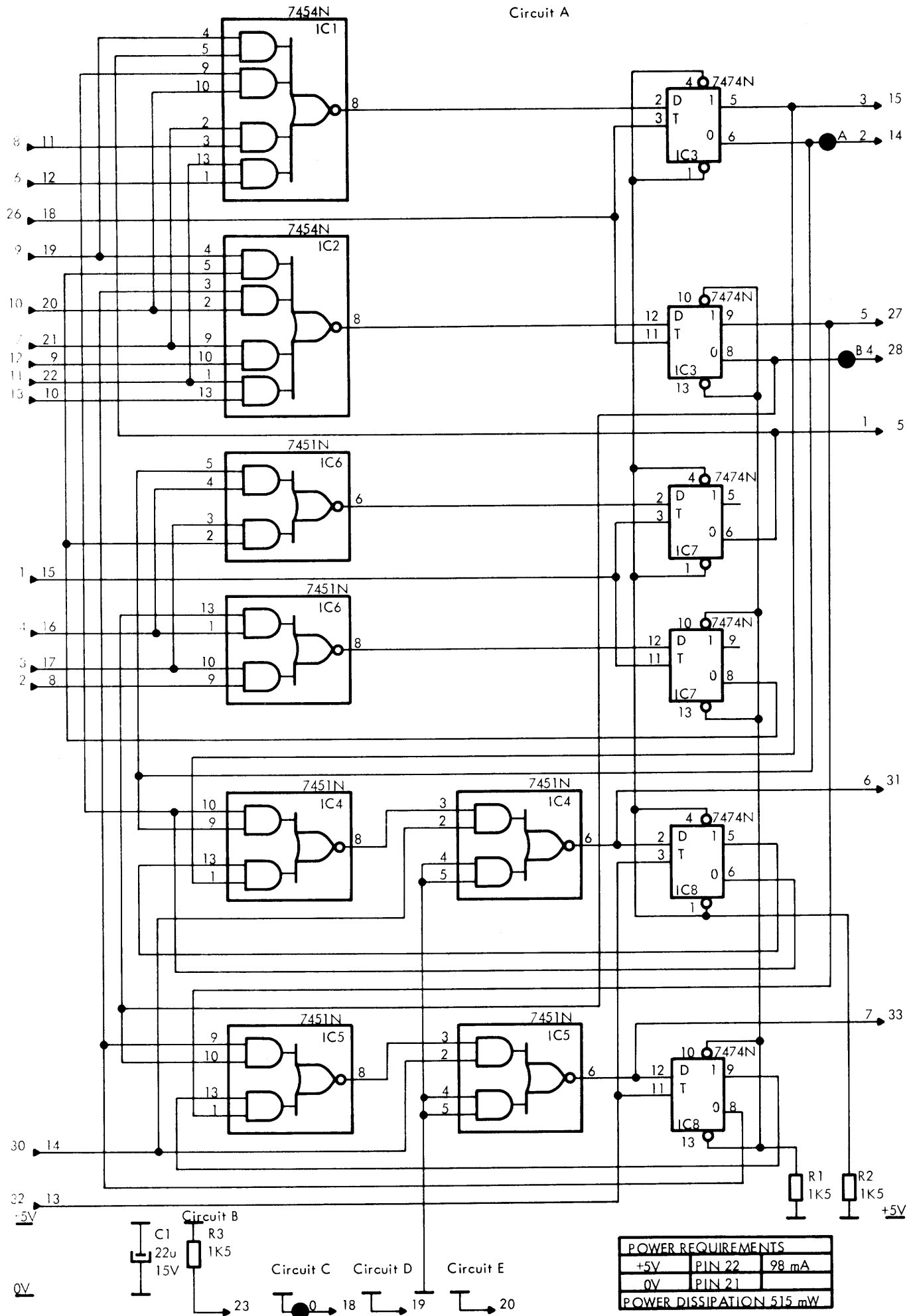

Circuit A

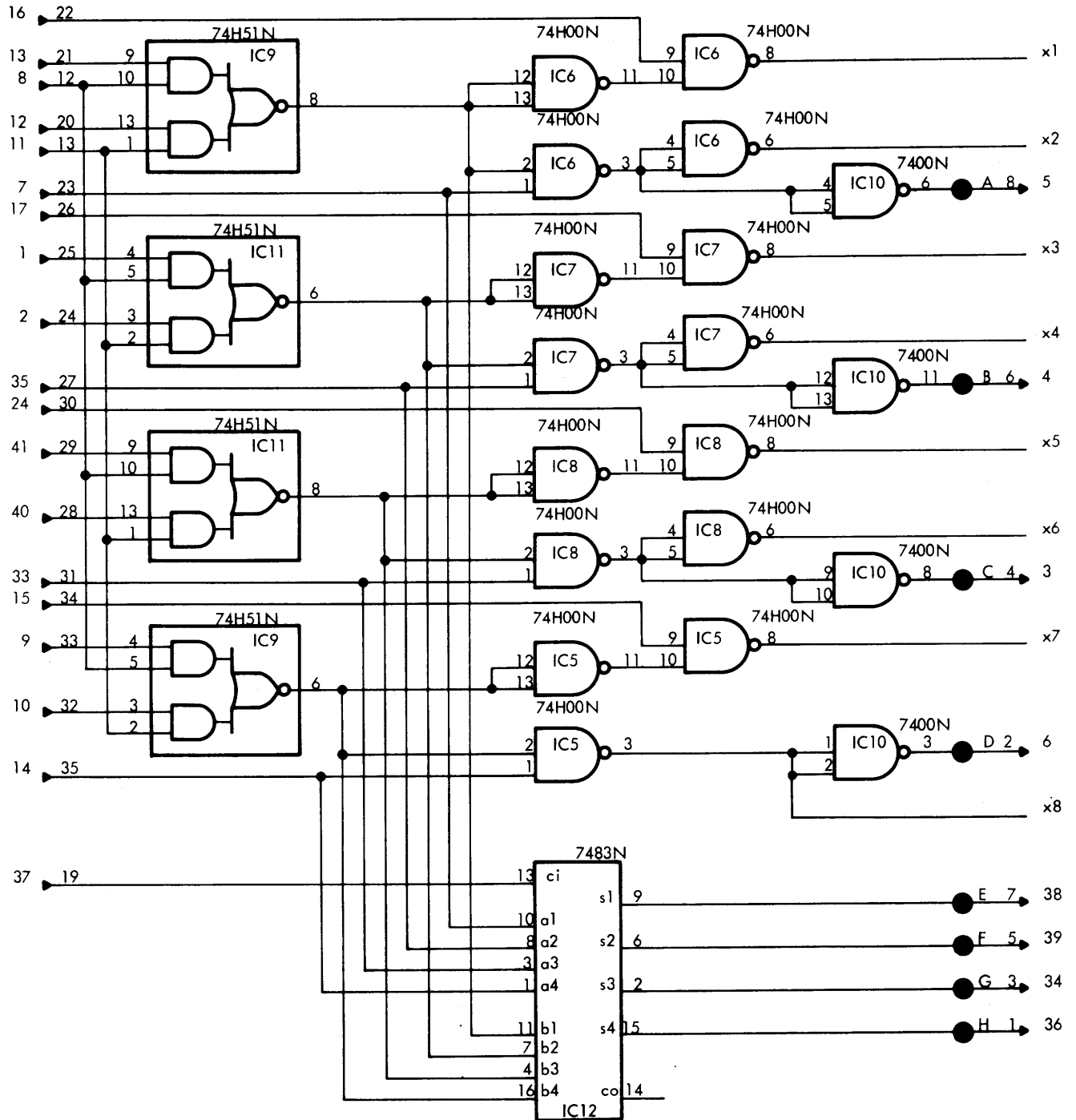

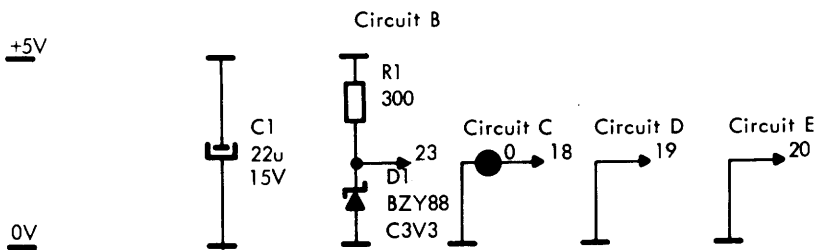
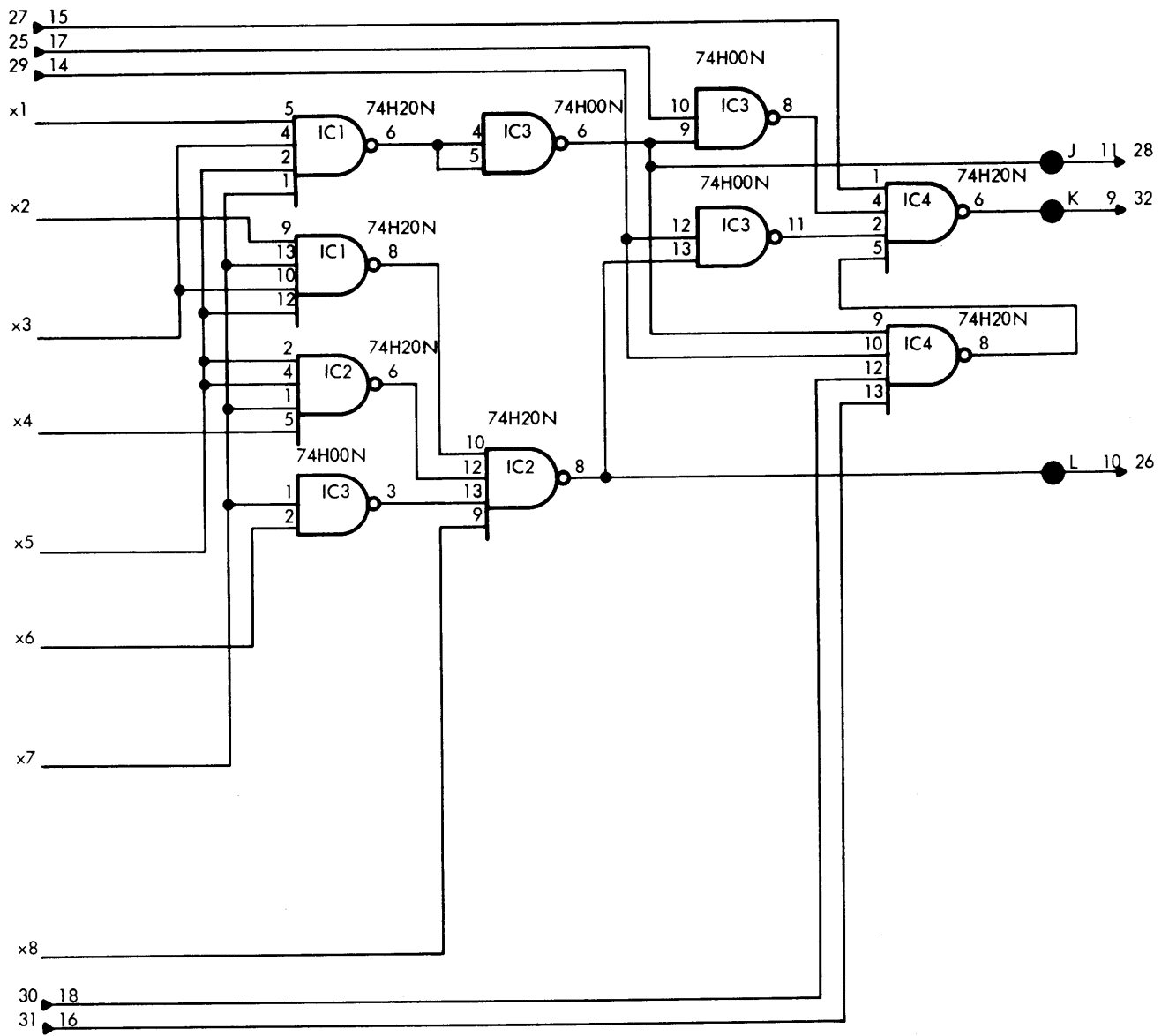

POWER REQUIREMENTS		
+5V	PIN 22	240mA
0V	PIN 21	
POWER DISSIPATION 1260mW		

0V

Circuit A

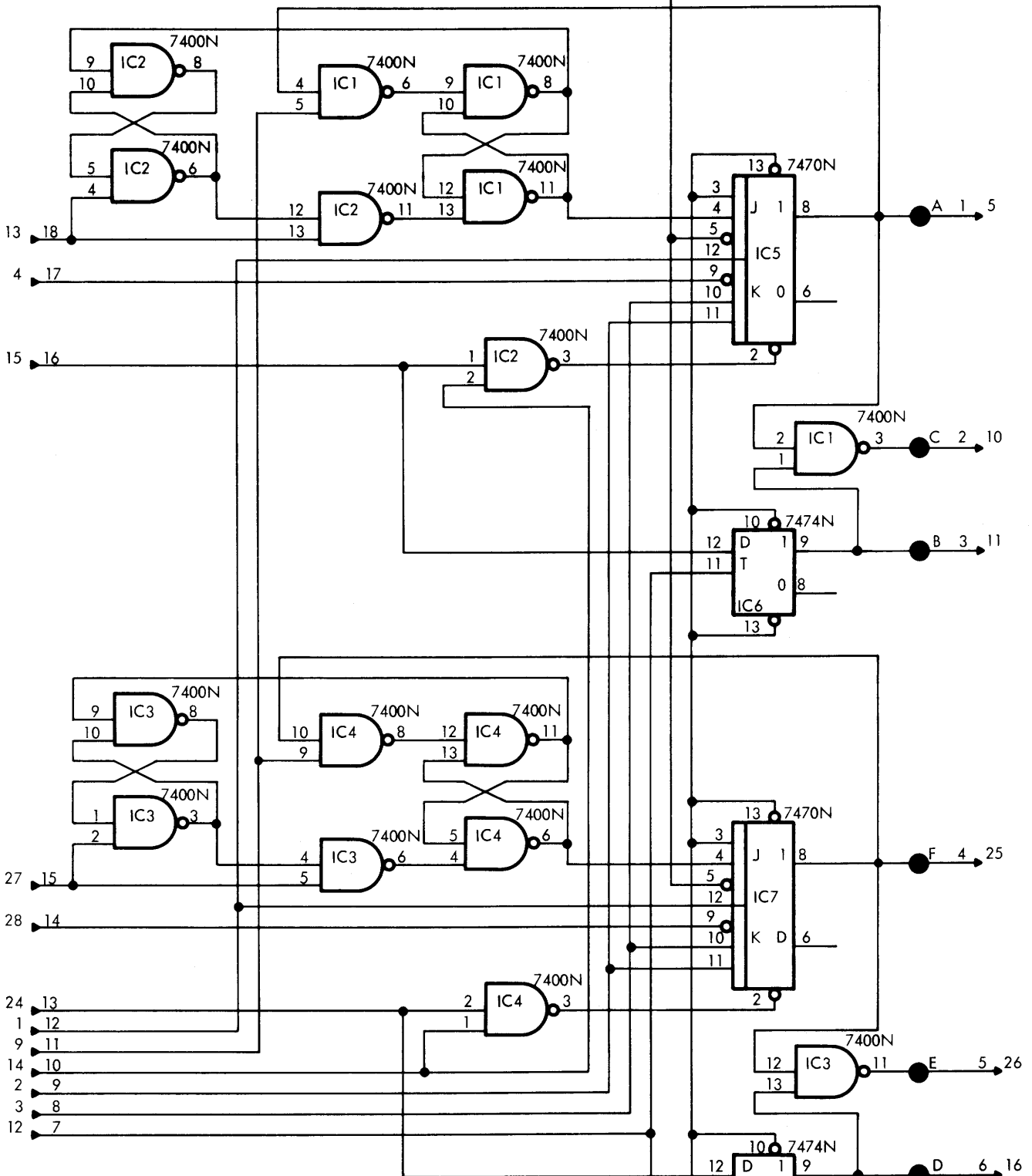

POWER REQUIREMENTS		
+5V	PIN 22	83 mA
0V	PIN 21	
POWER DISSIPATION 430 mW		

+5V

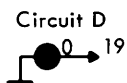
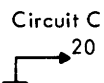
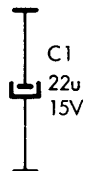

0V

Circuit B



Circuit A

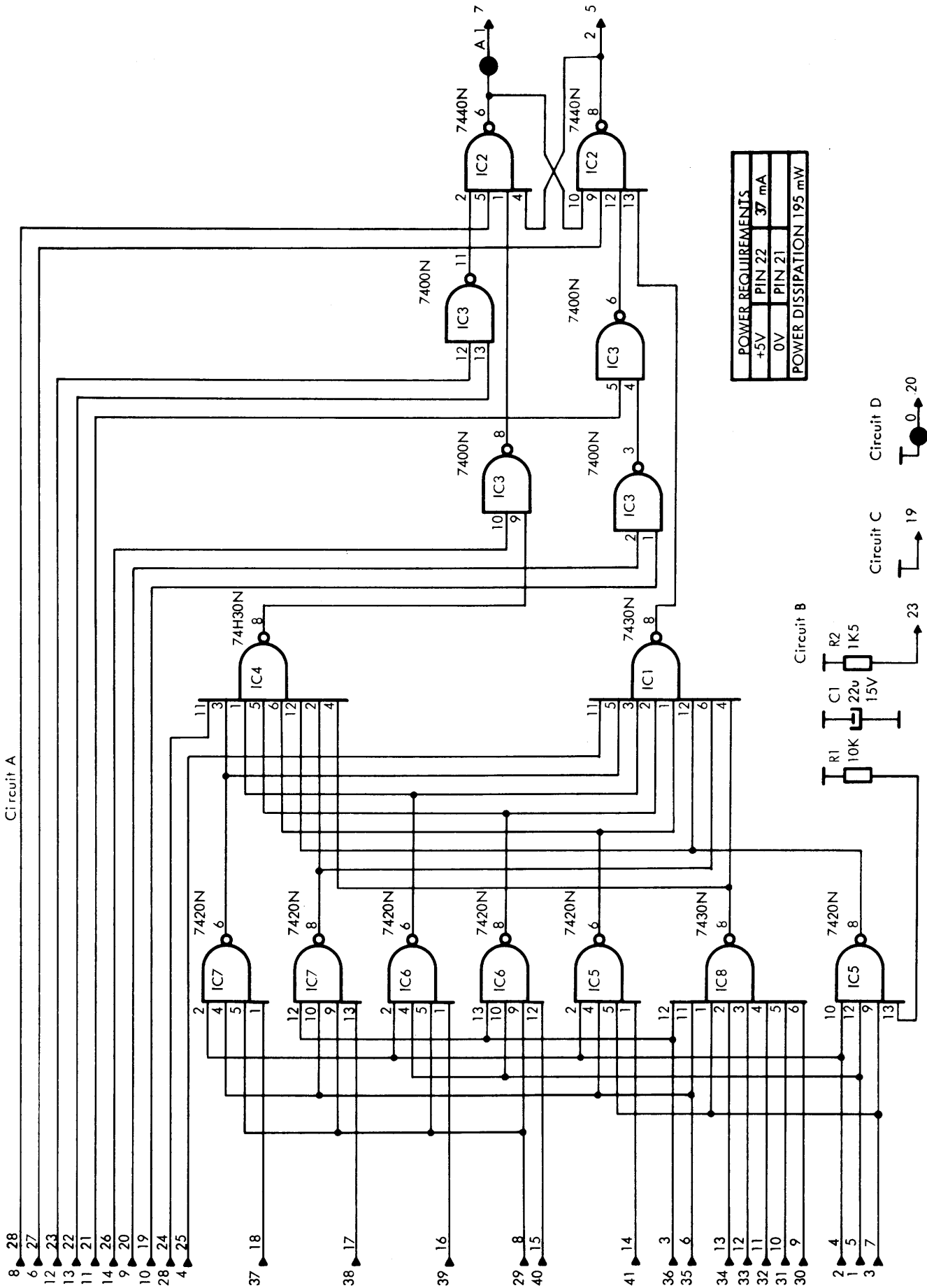

POWER REQUIREMENTS		
+5V	PIN 22	37 mA
0V	PIN 21	
POWER DISSIPATION 195 mW		

+5V

0V

+5V

Circuit A

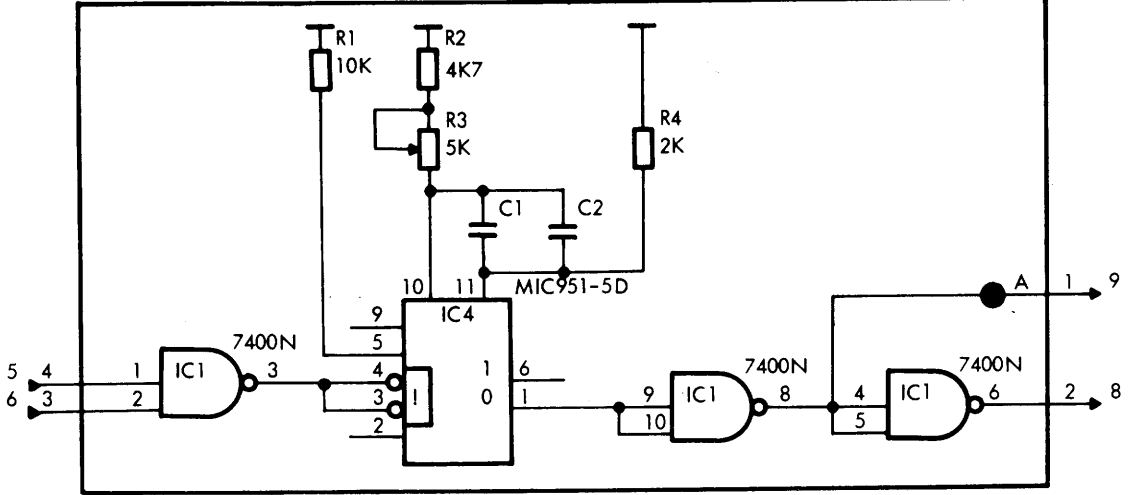

Circuit B

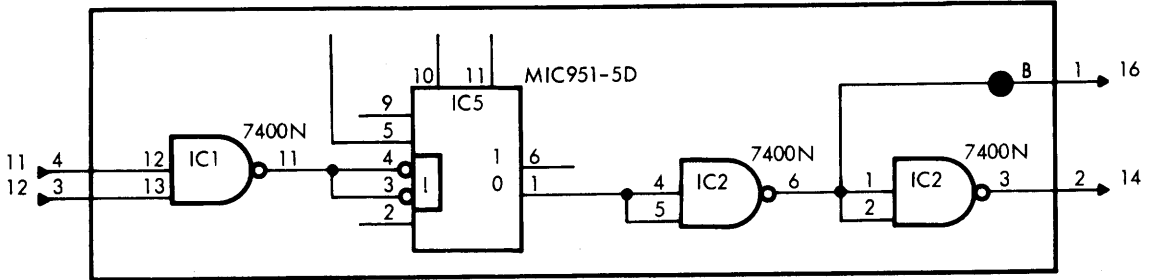

Circuit C

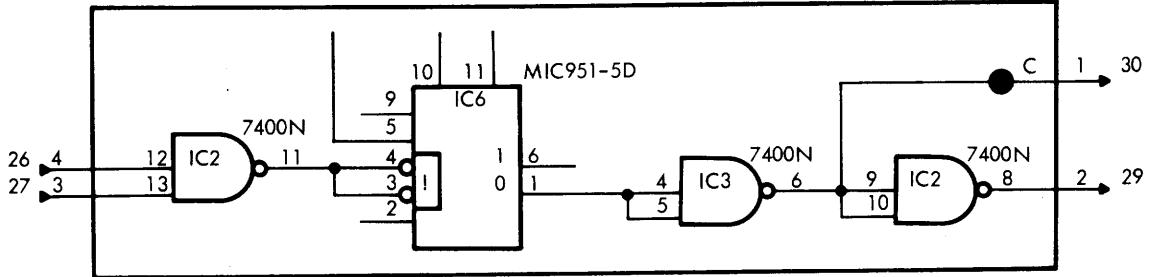

Circuit D

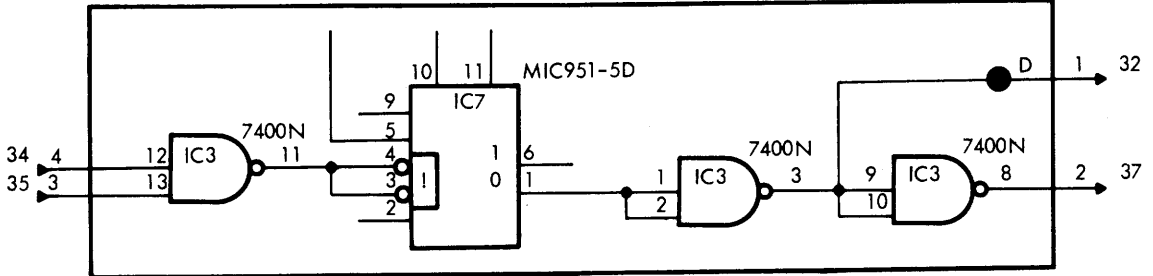

Circuit E

+5V

0V

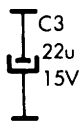

Circuit F

Circuit G

Circuit H

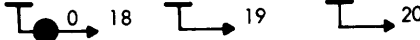

POWER REQUIREMENTS		
+5V	PIN 22	152mA
0V	PIN 21	
POWER DISSIPATION 800 mW		

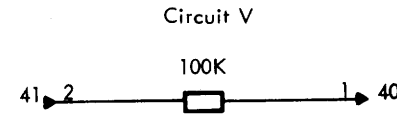
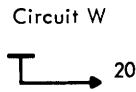
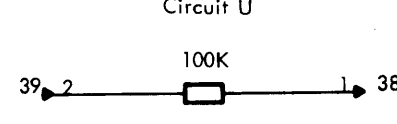
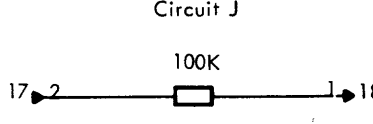
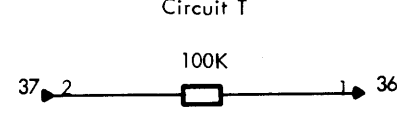
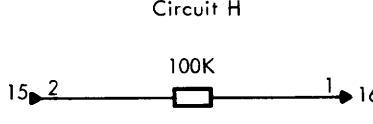
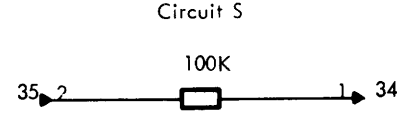
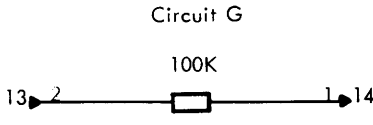
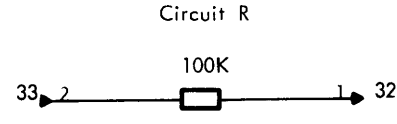
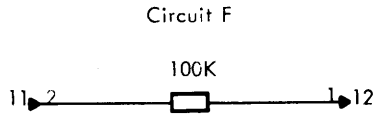
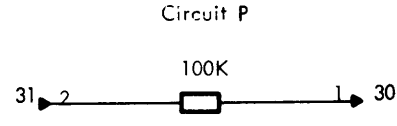
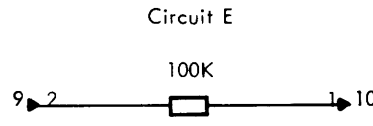
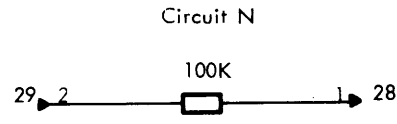
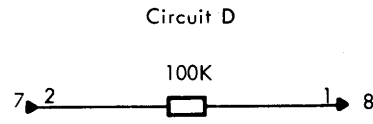
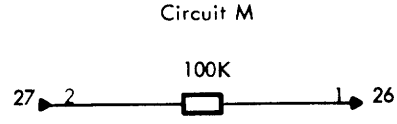
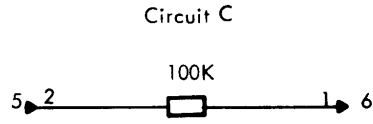
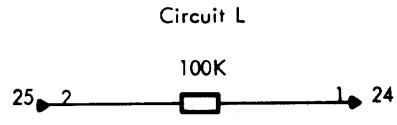
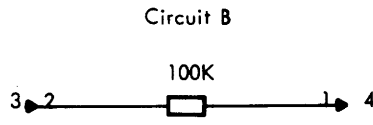
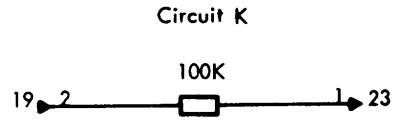
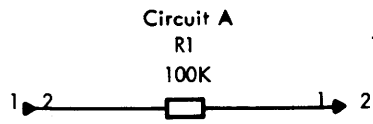

0V

POWER REQUIREMENTS		
+5V	PIN 22	0 mA
0V	PIN 21	
POWER DISSIPATION -		

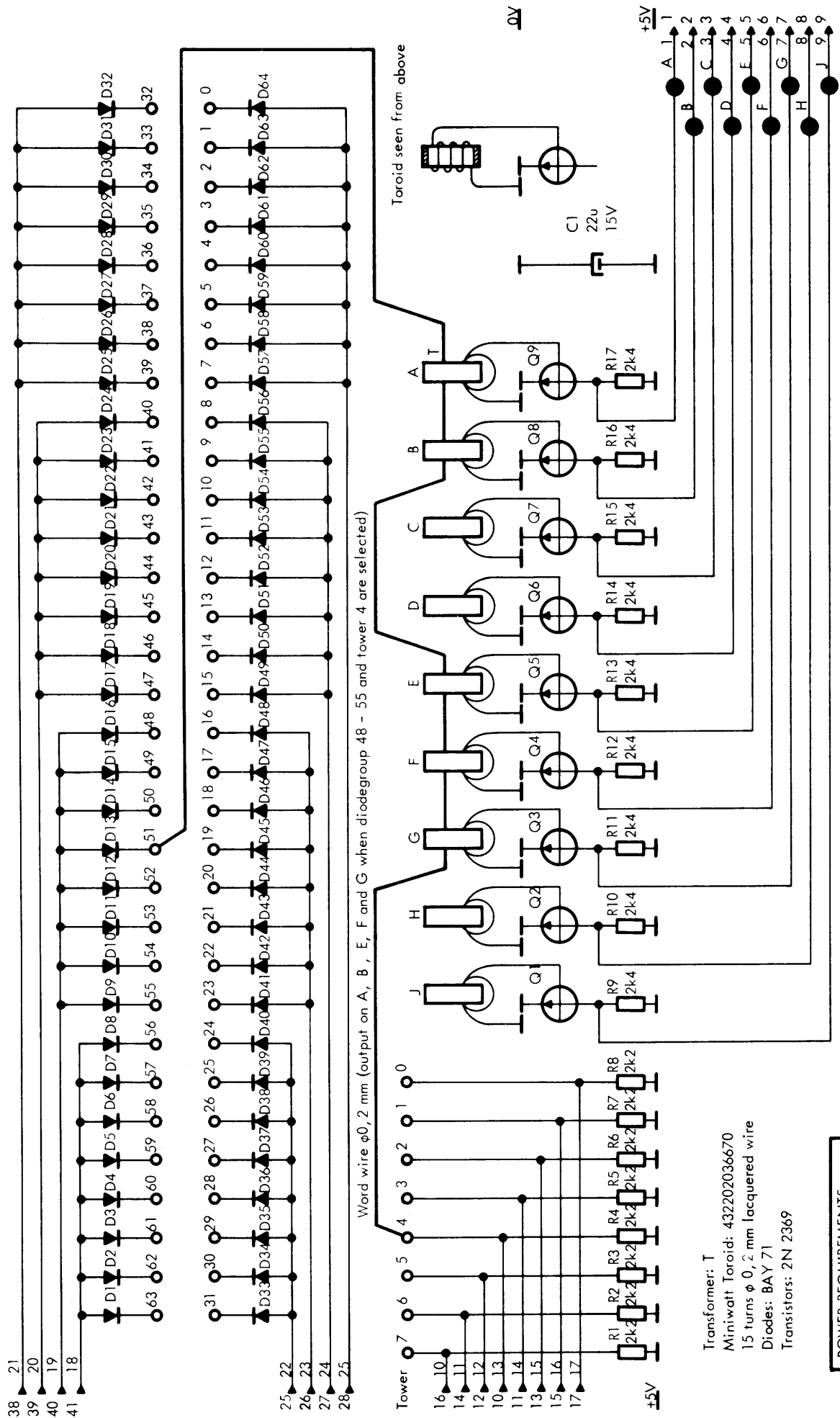

ECN 4014
 SP 8.9.72
 CPO 170

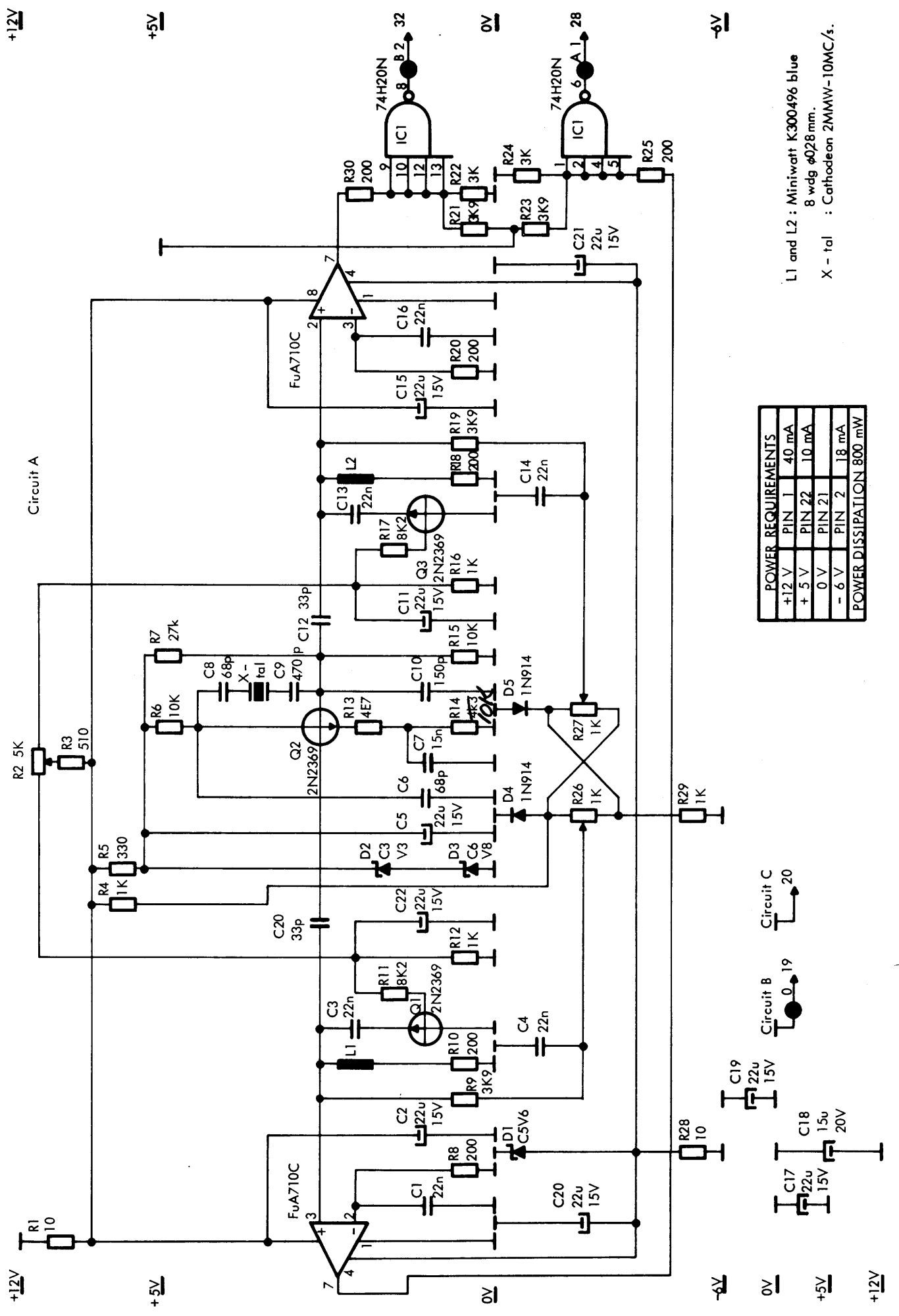

Circuit A

POWER REQUIREMENTS	
+12 V	PIN 1 40 mA
+ 5 V	PIN 22 10 mA
0 V	PIN 21
- 6 V	PIN 2 18 mA
POWER DISSIPATION 800 mW	

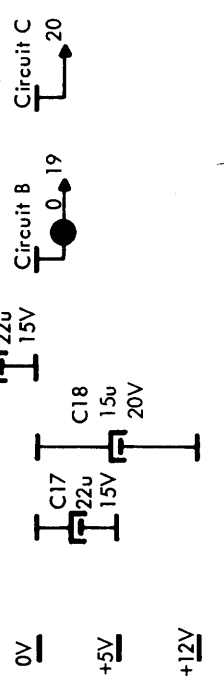

L1 and L2 : Miniwatt K300496 blue
 8 wdg ø028mm.
 X - tal : Cathodeon 2MMW-10MC/s.

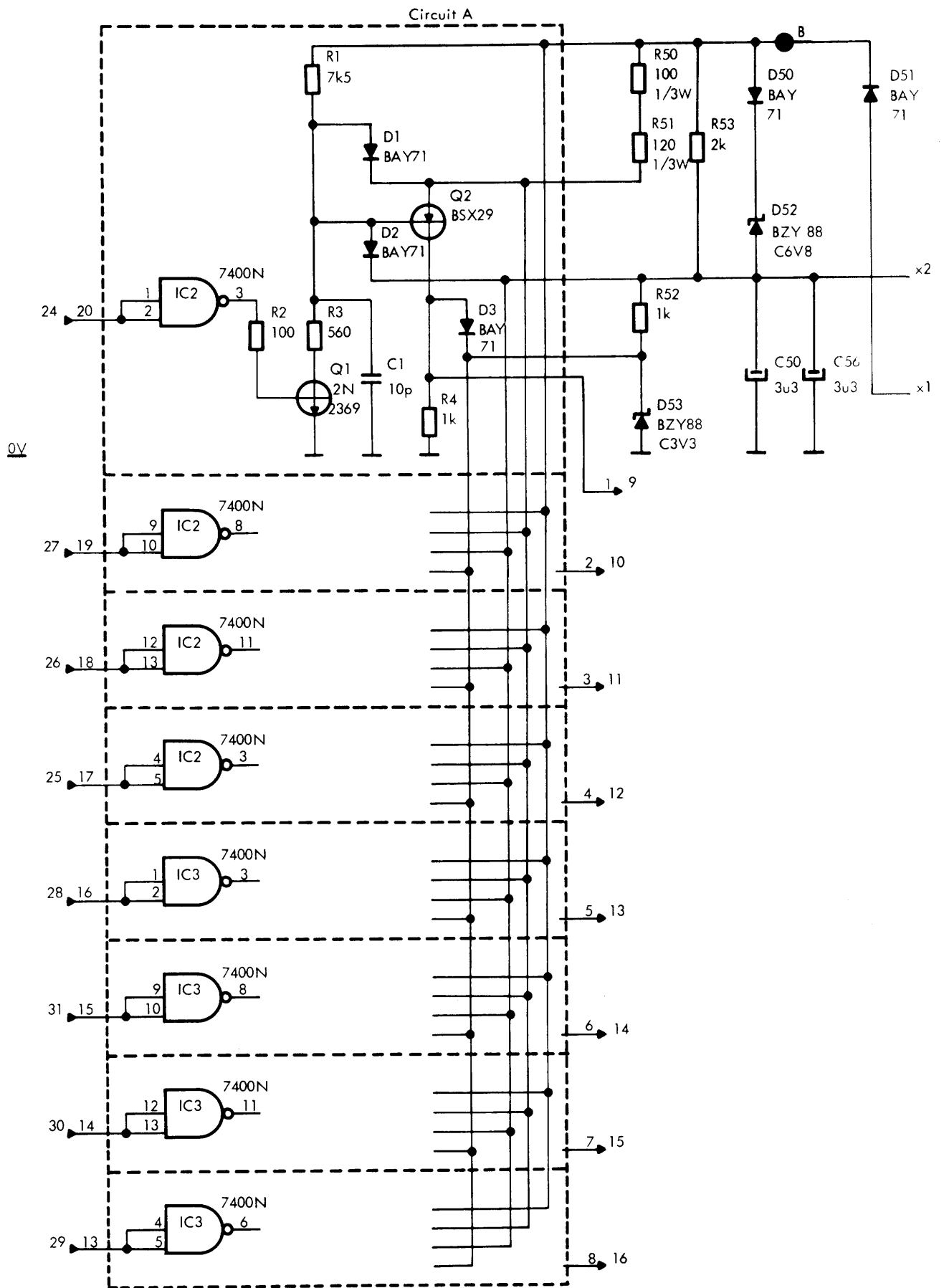

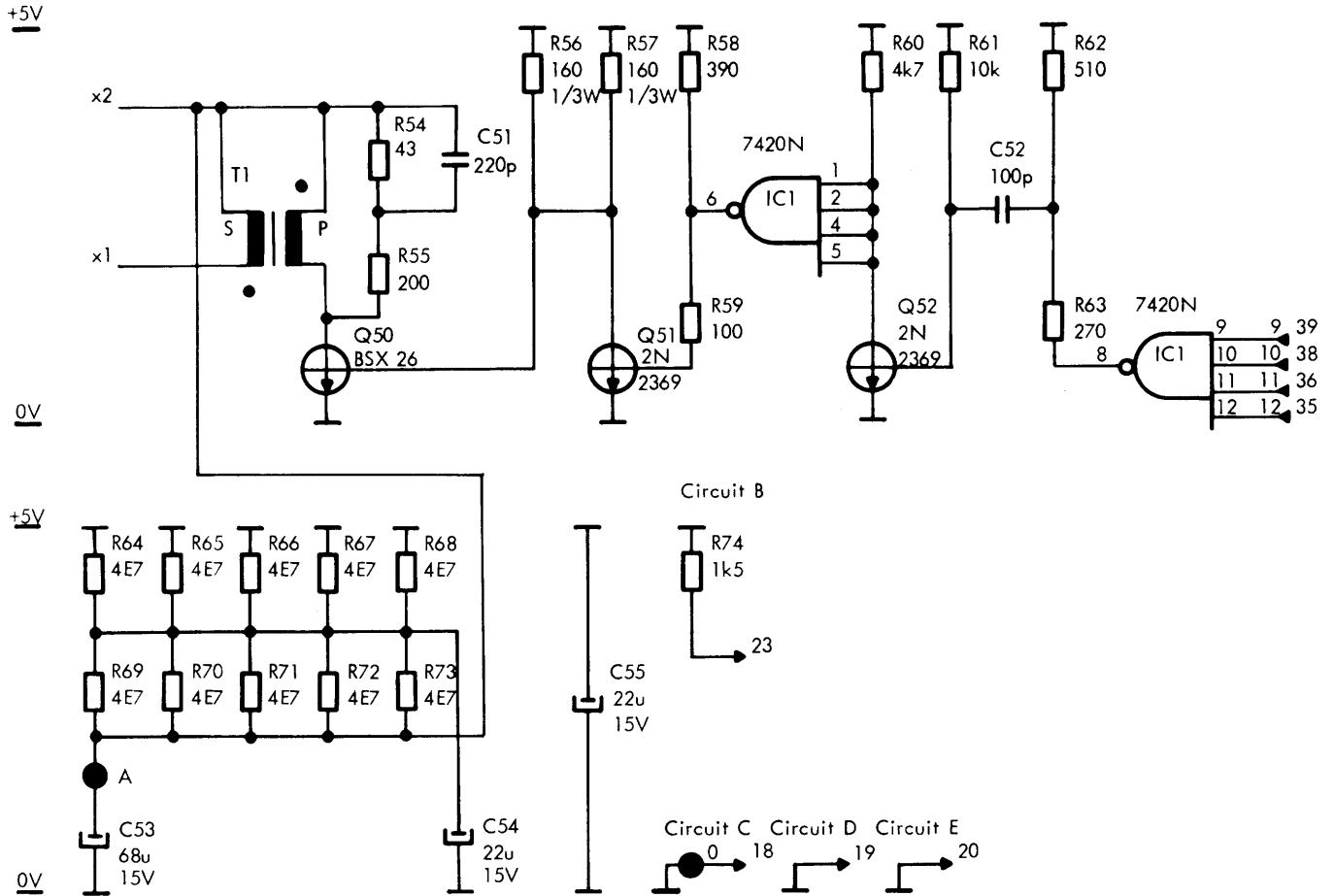

T1: Miniwat
4322-020-36660

P : 10 wdg ϕ 0,28 mm

S : 30 wdg ϕ 0,20 mm

POWER REQUIREMENTS		
+5V	PIN 22	250mA
0V	PIN 21	
POWER DISSIPATION 1250mW		

+5V

0V

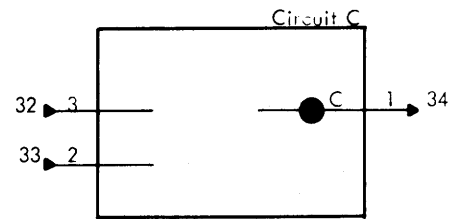
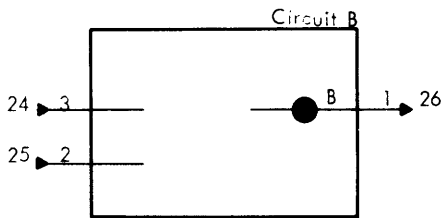
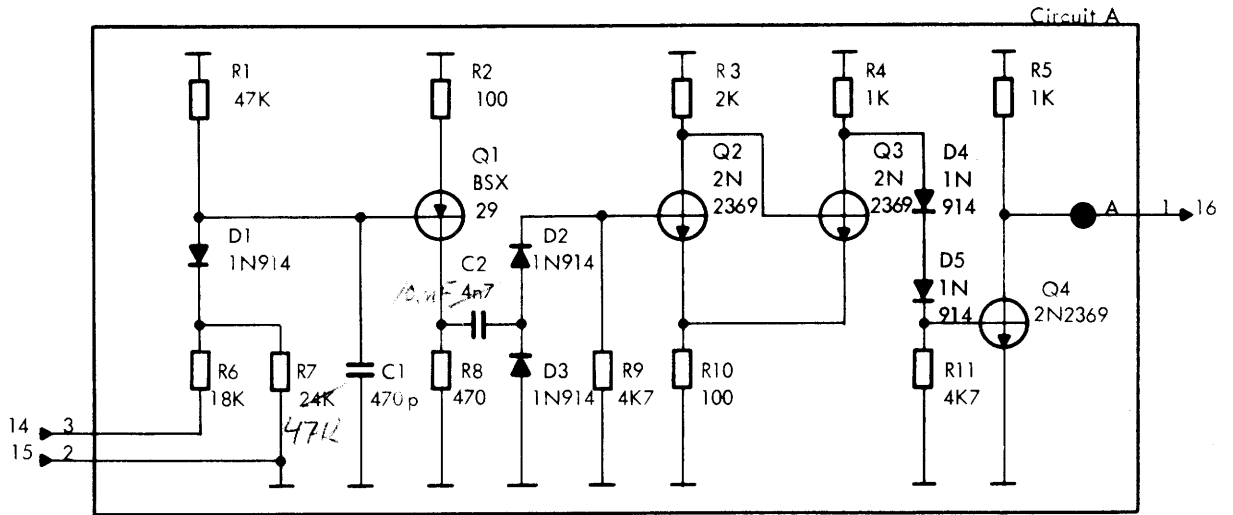

+5V

0V

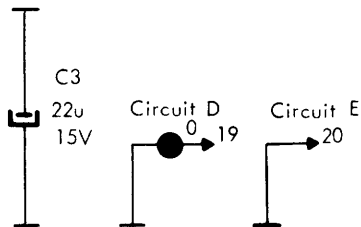

POWER REQUIREMENTS		
+5V	PIN 22	60 mA
0V	PIN 21	
POWER DISSIPATION 350 mW		

Eddal SP 27.12.71

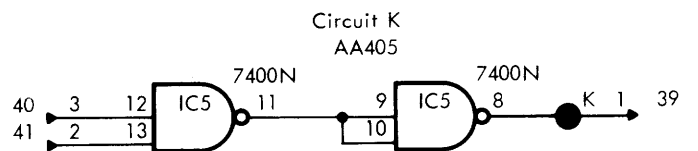
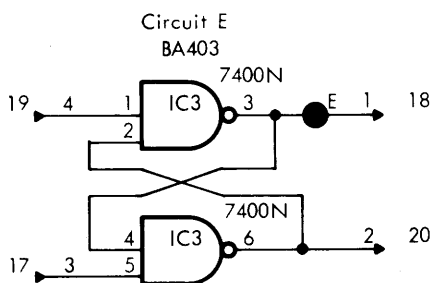
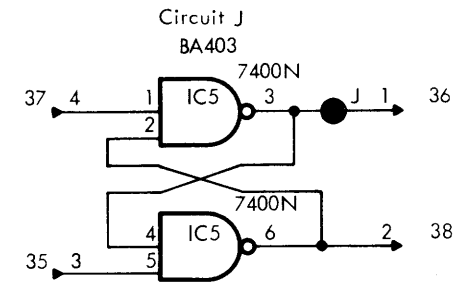
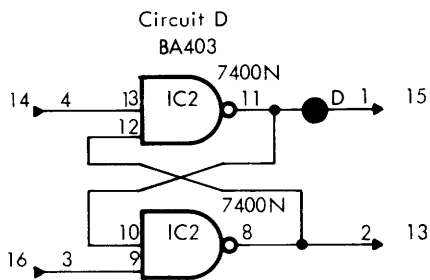
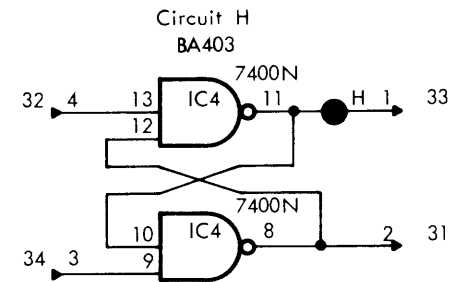
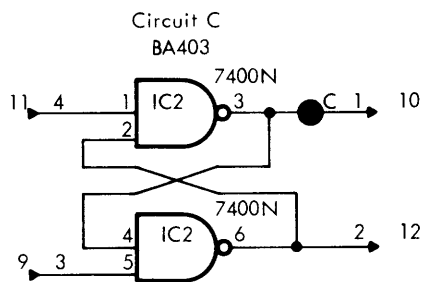
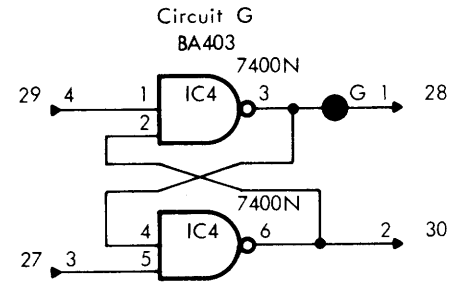
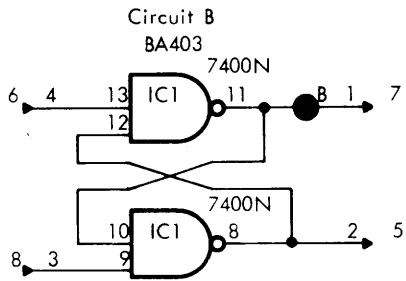
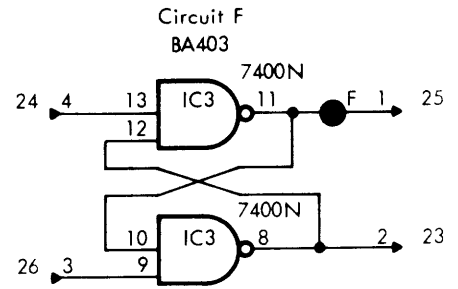
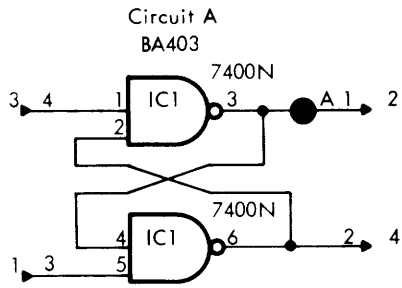

+5V

0V

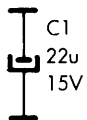

POWER REQUIREMENTS		
+5 V	PIN 22	44mA
0 V	PIN 21	
POWER DISSIPATION 235mW		

Circuit A

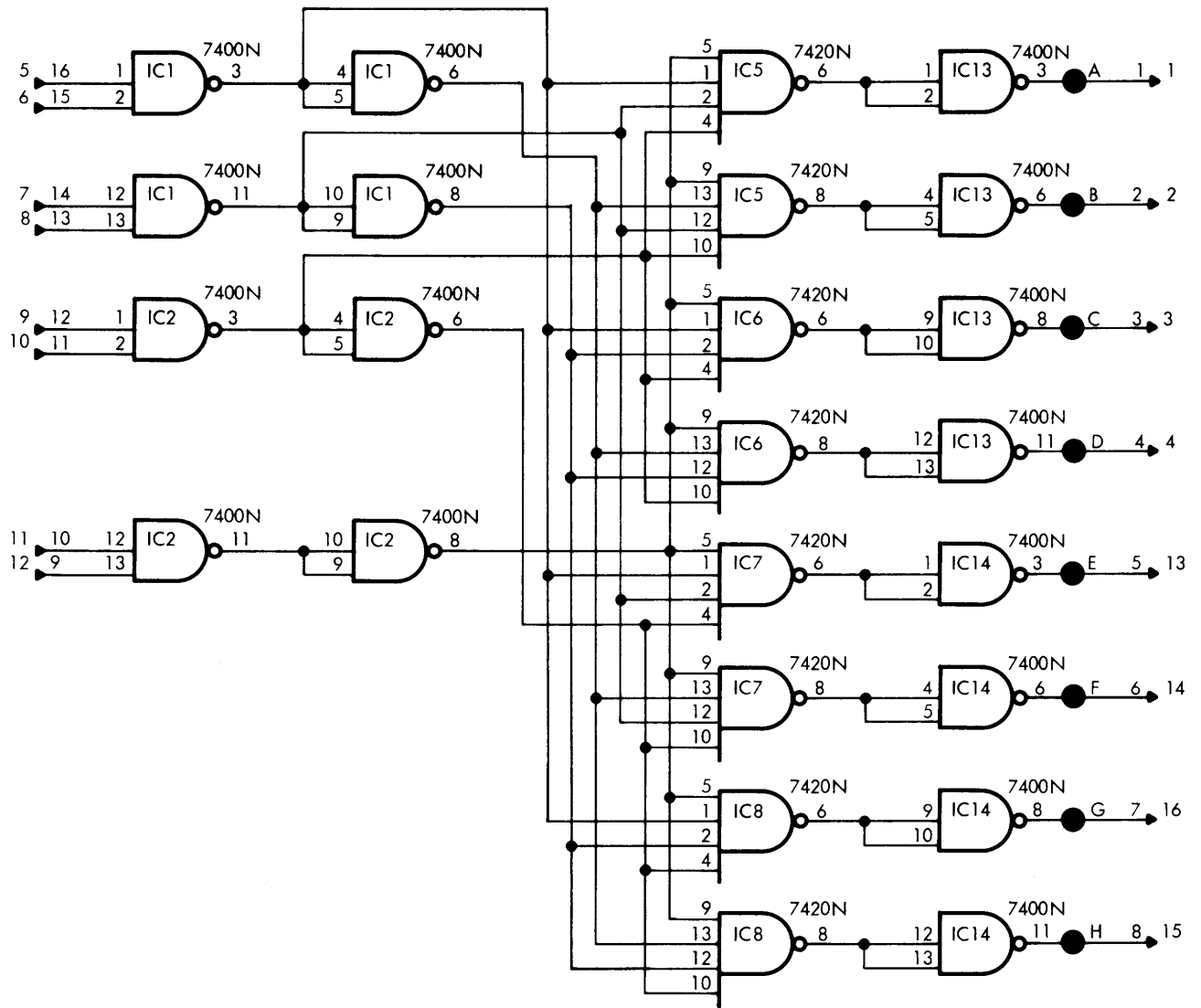

Circuit B

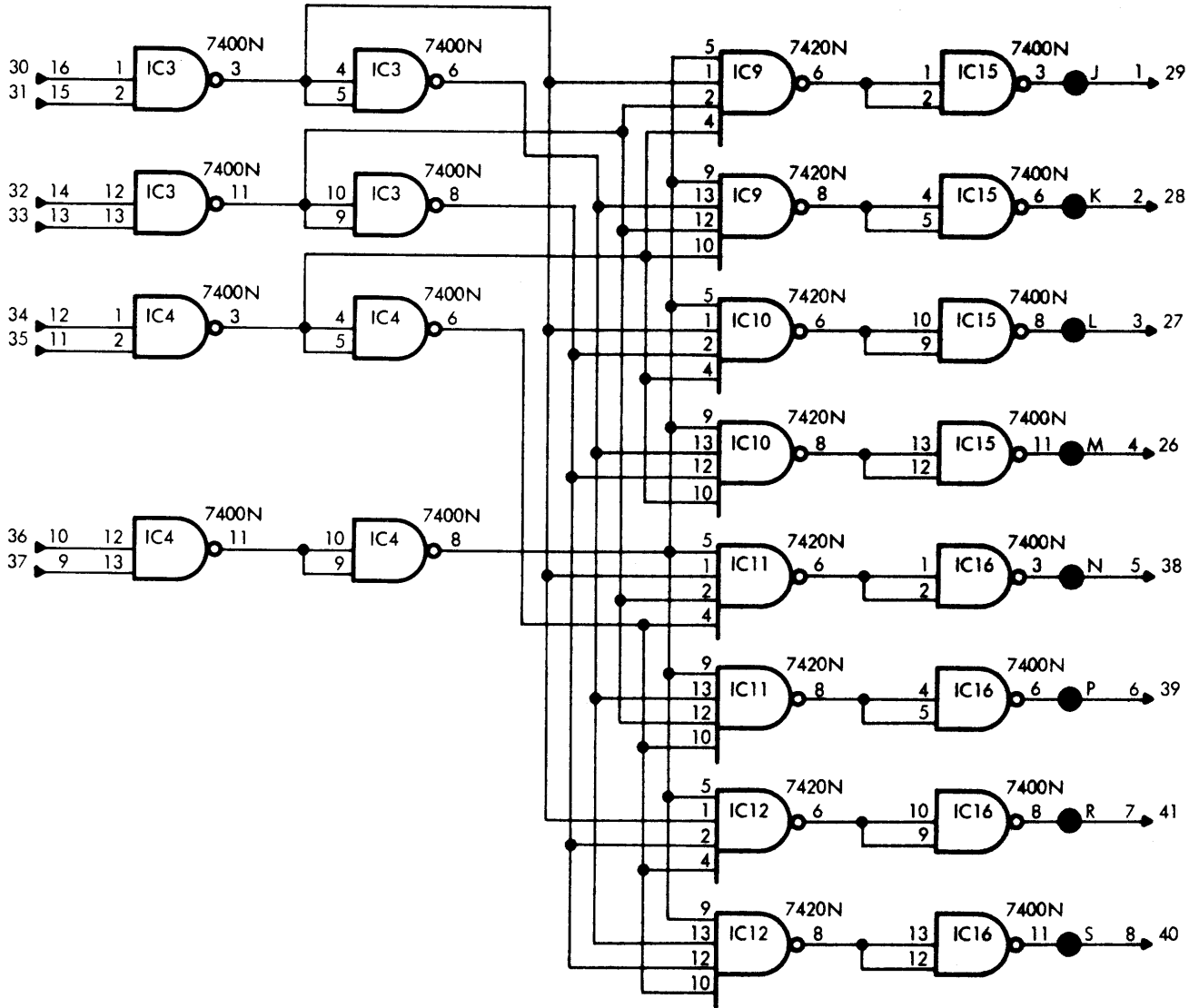

+5V

0V

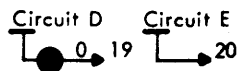
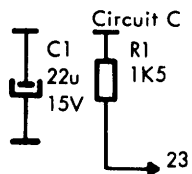

POWER REQUIREMENTS		
+5V	PIN 22	110mA
0V	PIN 21	
POWER DISSIPATION 580mW		

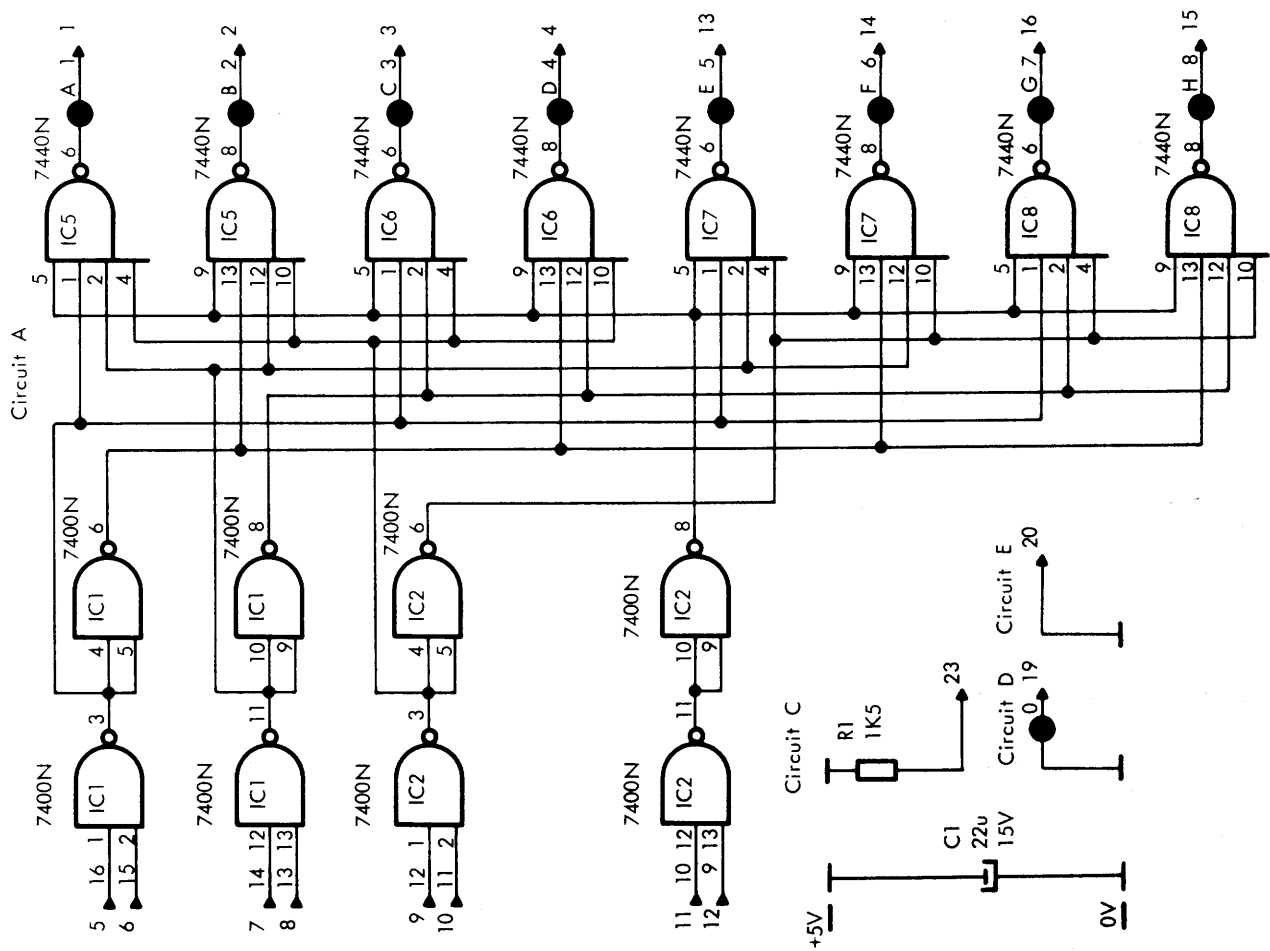
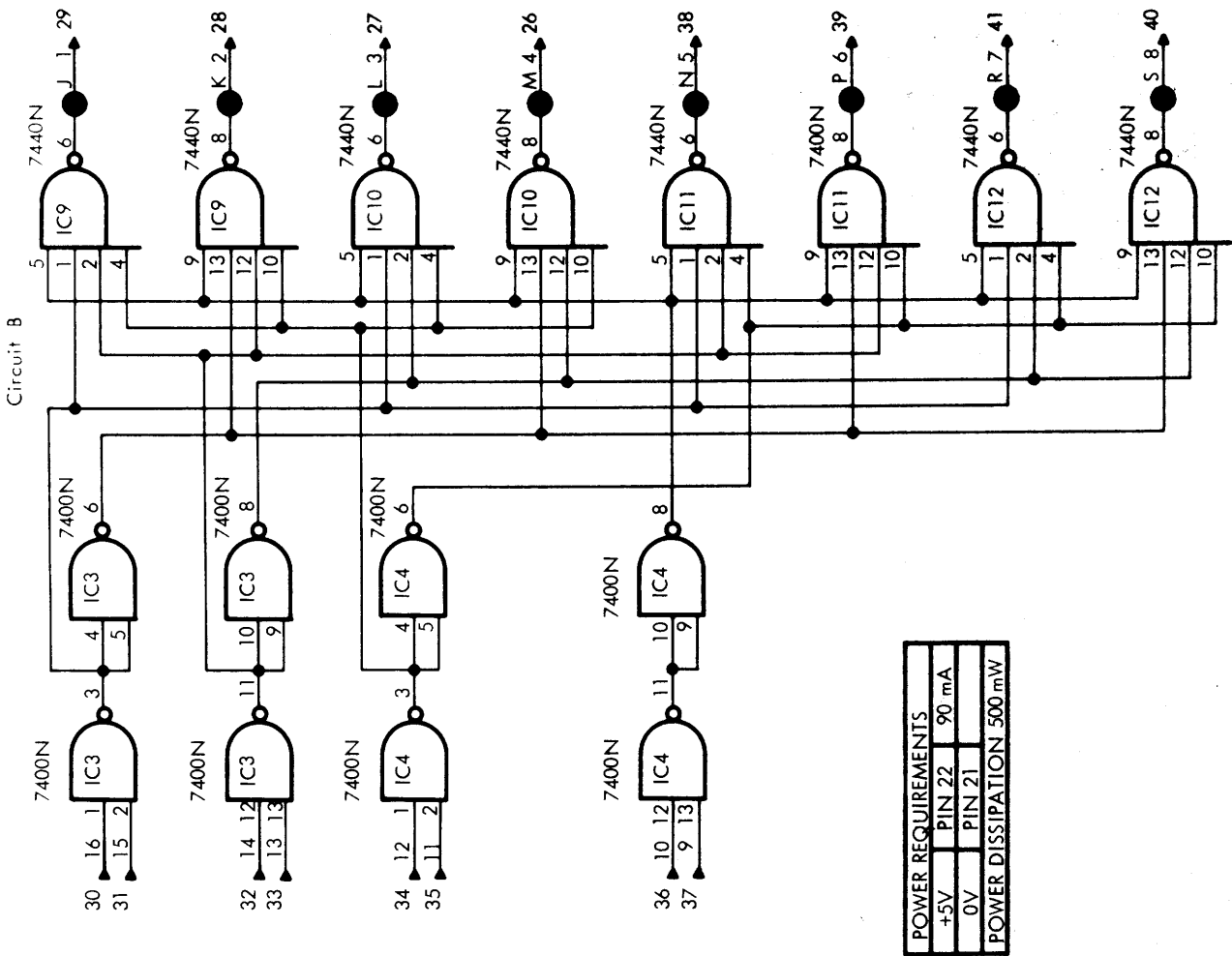

Circuit A

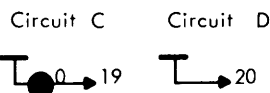
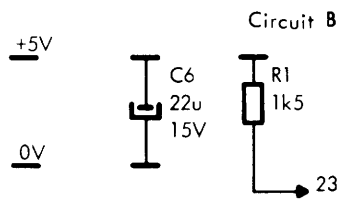
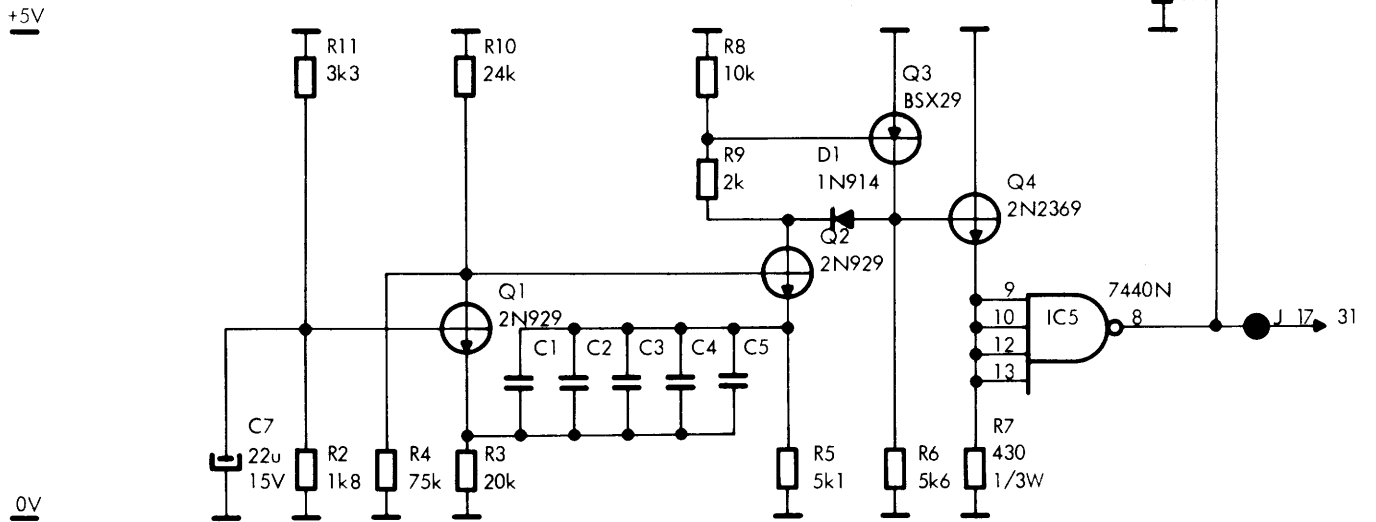
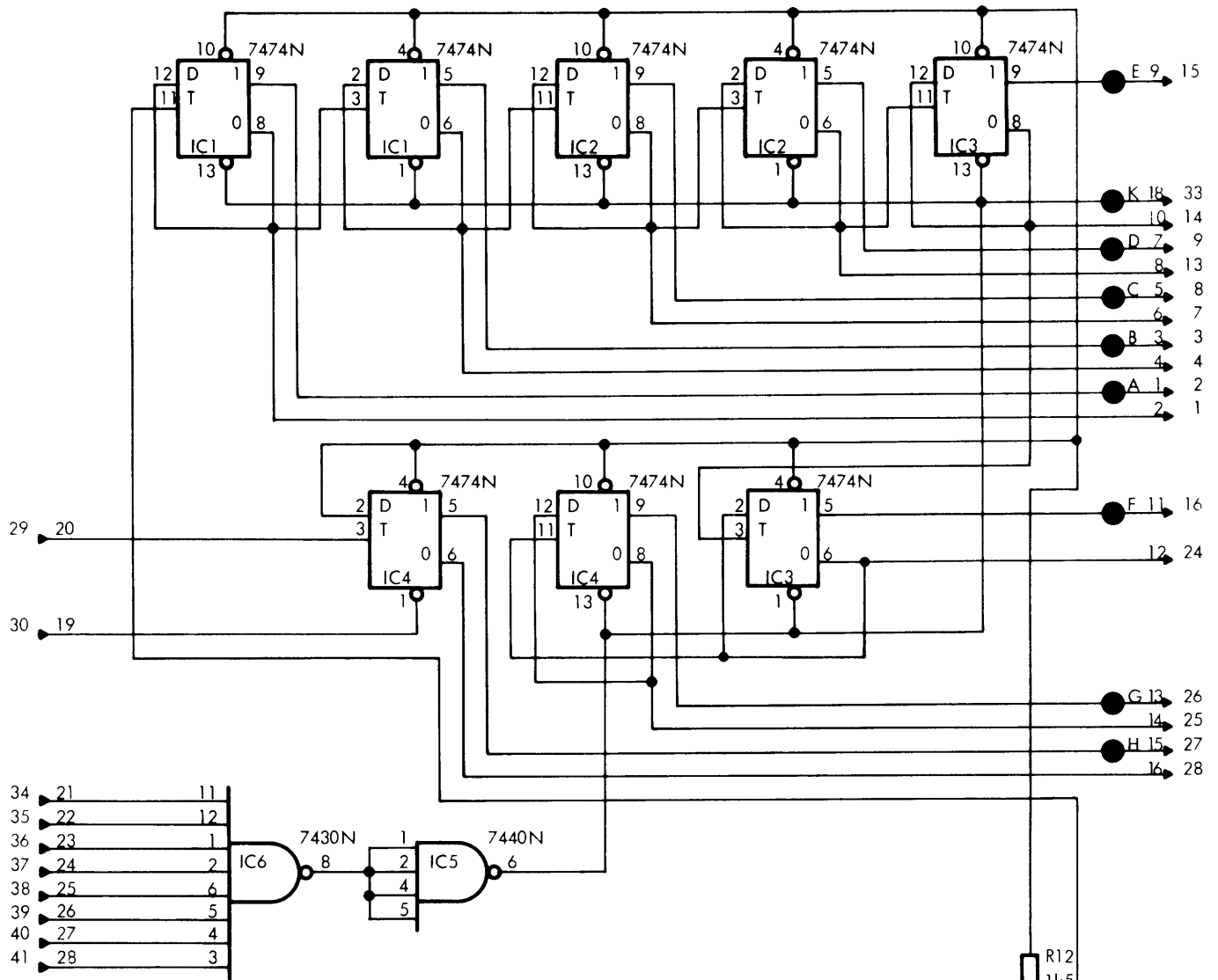

POWER REQUIREMENTS		
+5V	PIN 22	115 mA
0V	PIN 21	
POWER DISSIPATION 600 mW		

+12V
+5V

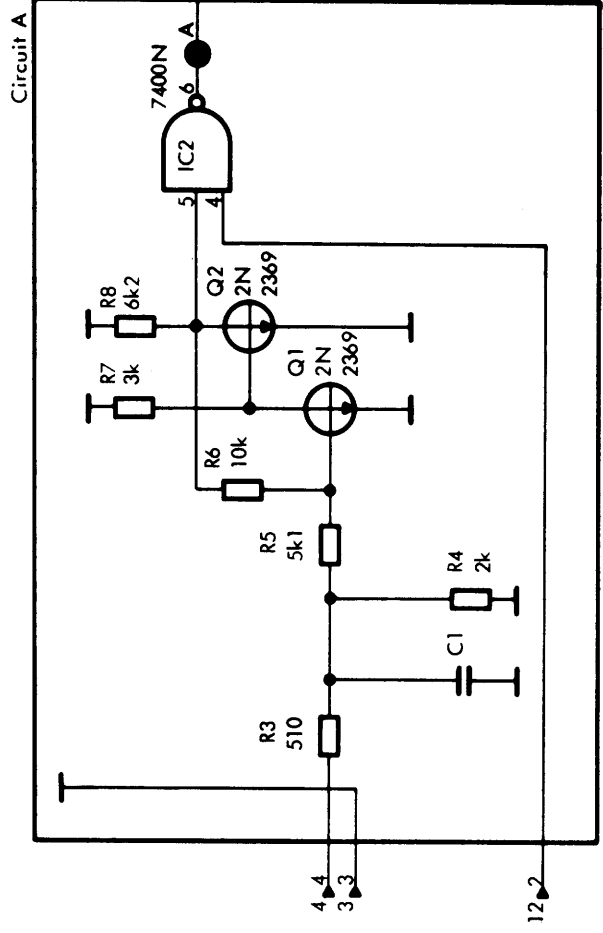

+12V
+5V

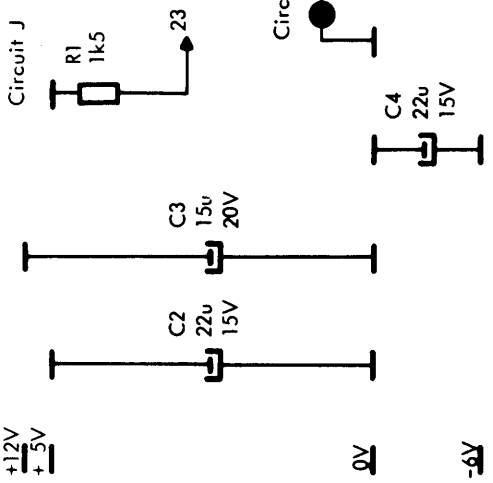

+12V
+5V

0V
-6V

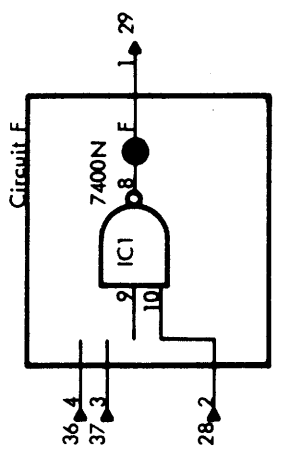
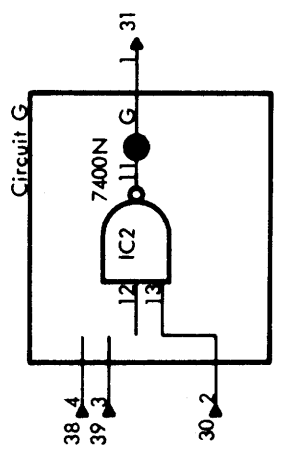
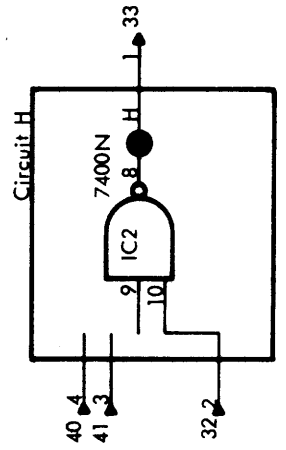
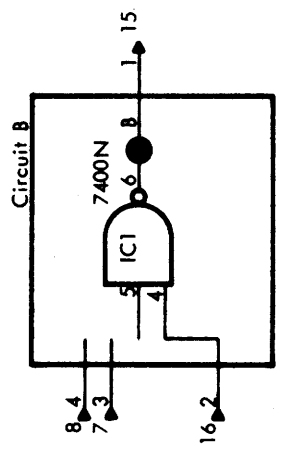
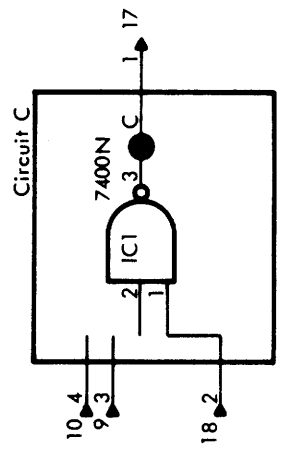
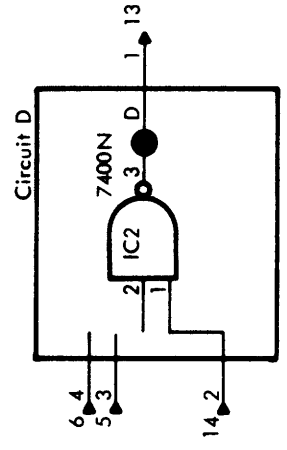
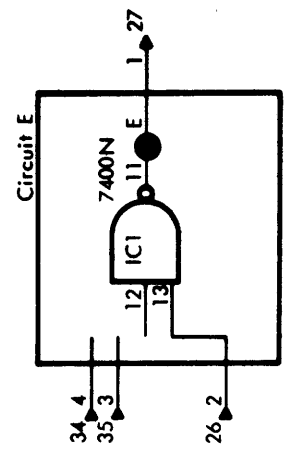

POWER REQUIREMENTS	
+12V	PIN 1 26 mA
+5V	PIN 22 55 mA
0V	PIN 21
-6V	PIN 2 67 mA
POWER DISSIPATION 1670mW	

+5V

0V

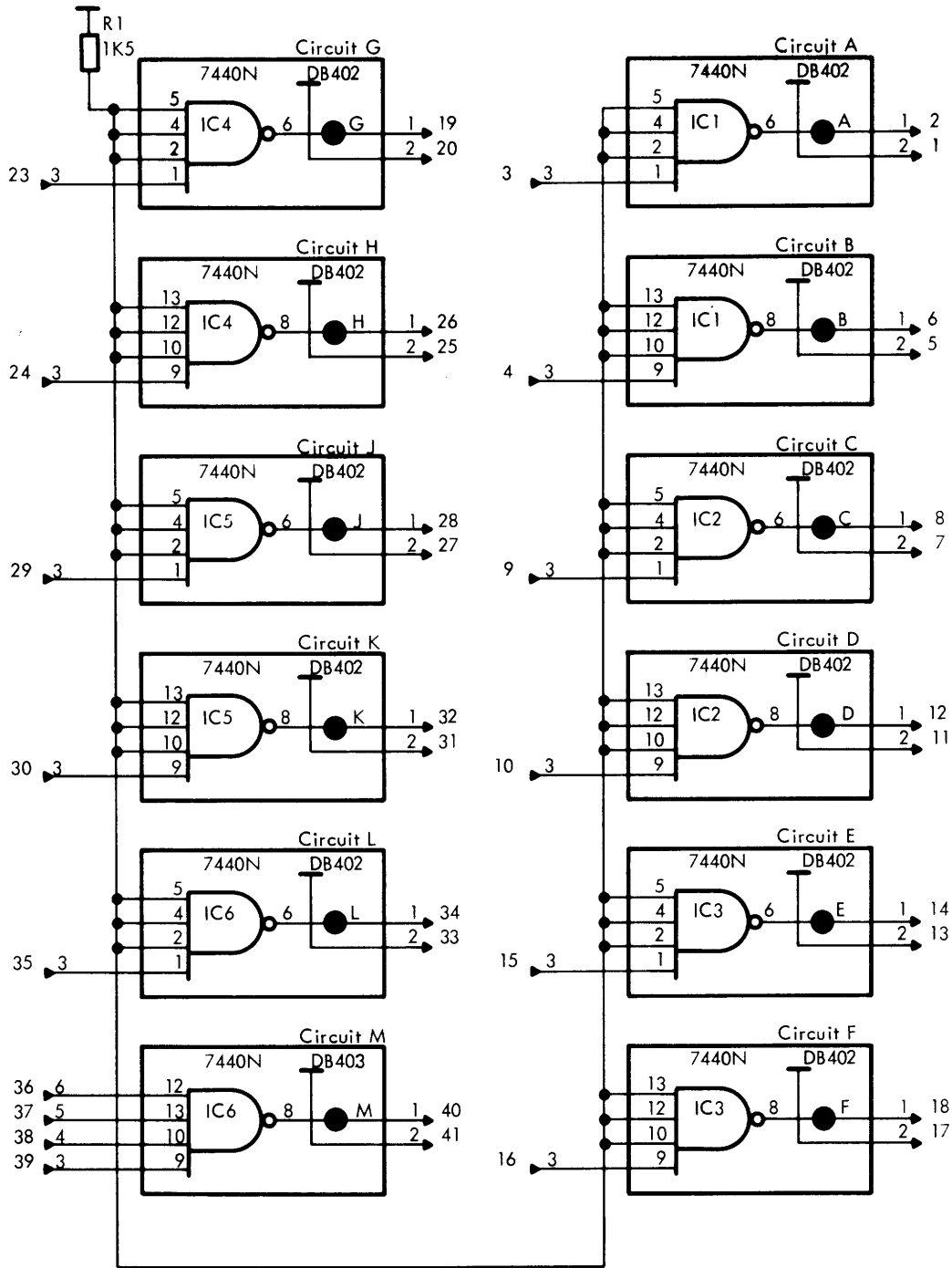

0V

0V

0V

0V

0V

+5V

0V

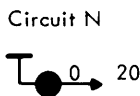
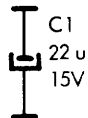

POWER REQUIREMENTS		
+5V	PIN 22	120 mA
0V	PIN 21	
POWER DISSIPATION 840 mW		

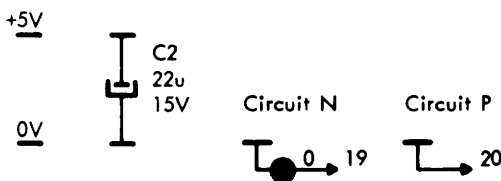
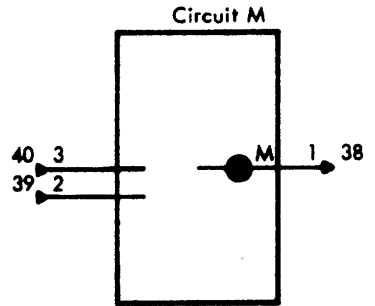
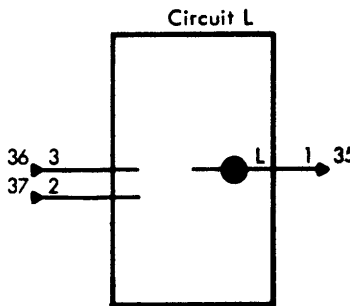
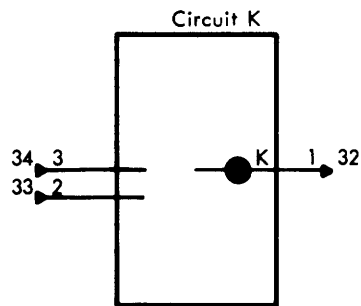
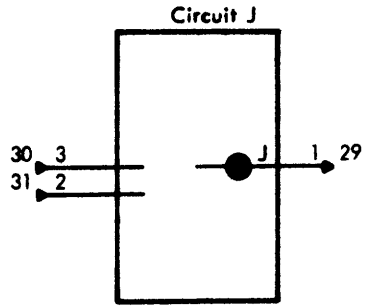
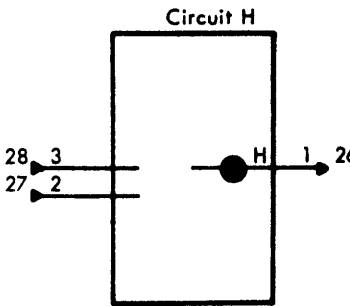
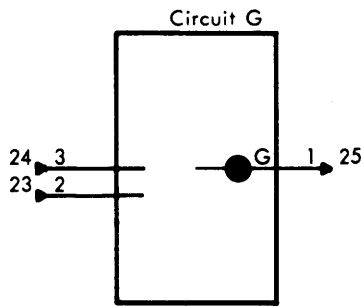
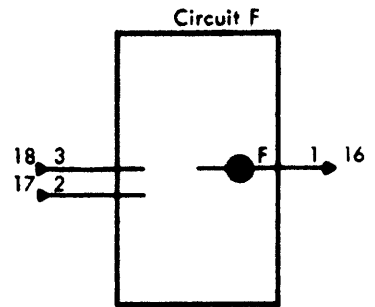
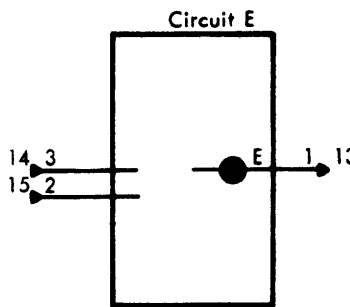
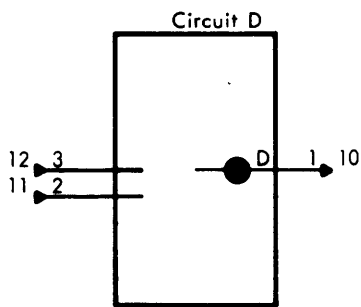
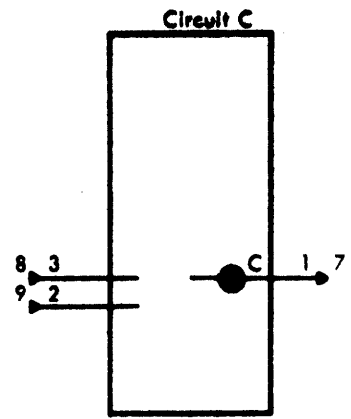
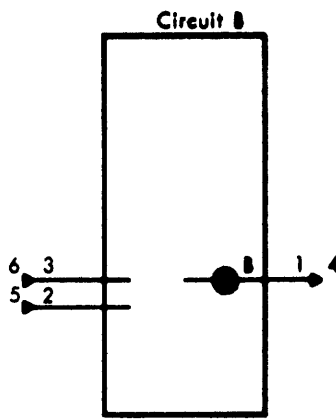
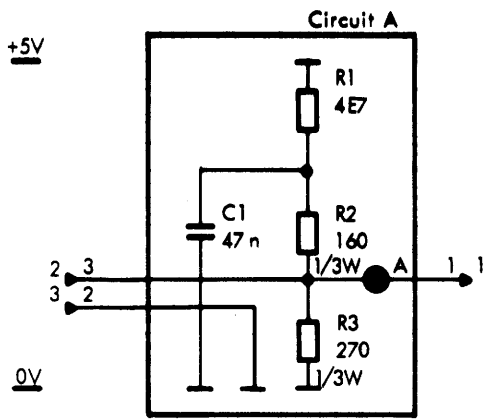

POWER REQUIREMENTS		
+5V	PIN 22	412mA
0V	PIN 21	
POWER DISSIPATION 2.2W		

+5V

0V

-16V

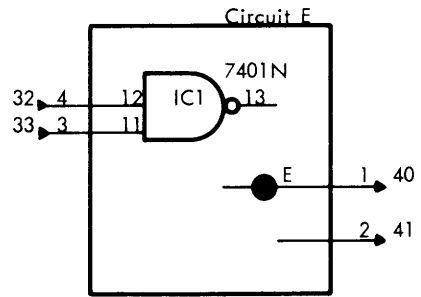
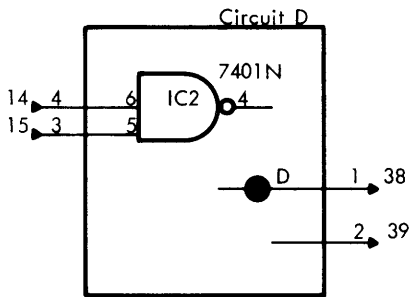
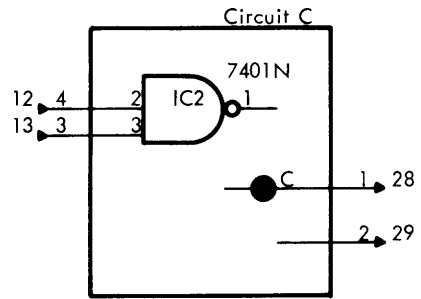
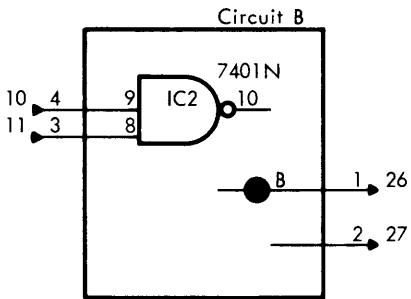
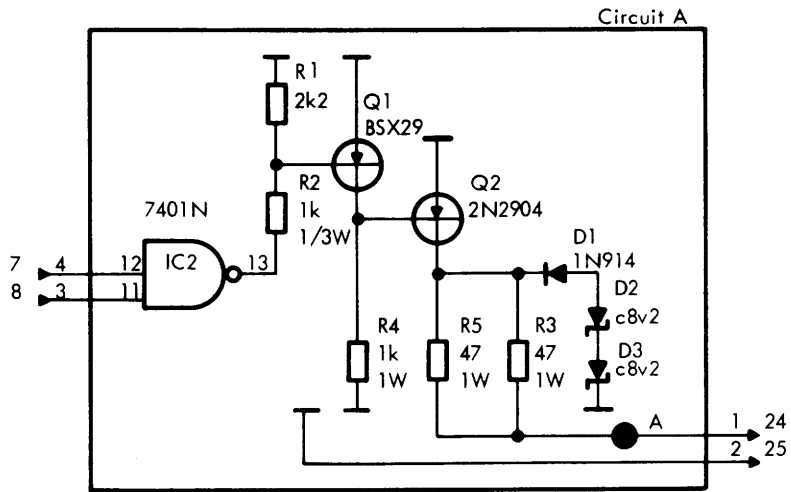

+5V

0V

-16V

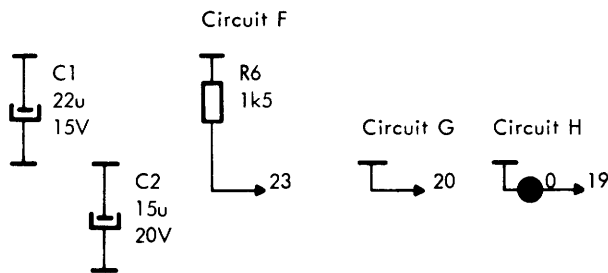

POWER REQUIREMENTS		
+5V	PIN 22	160mA
0V	PIN 21	
-16V	PIN 4	105mA
POWER DISSIPATION 2.8 W		

Zenerdiodes are BZY88

Circuit A

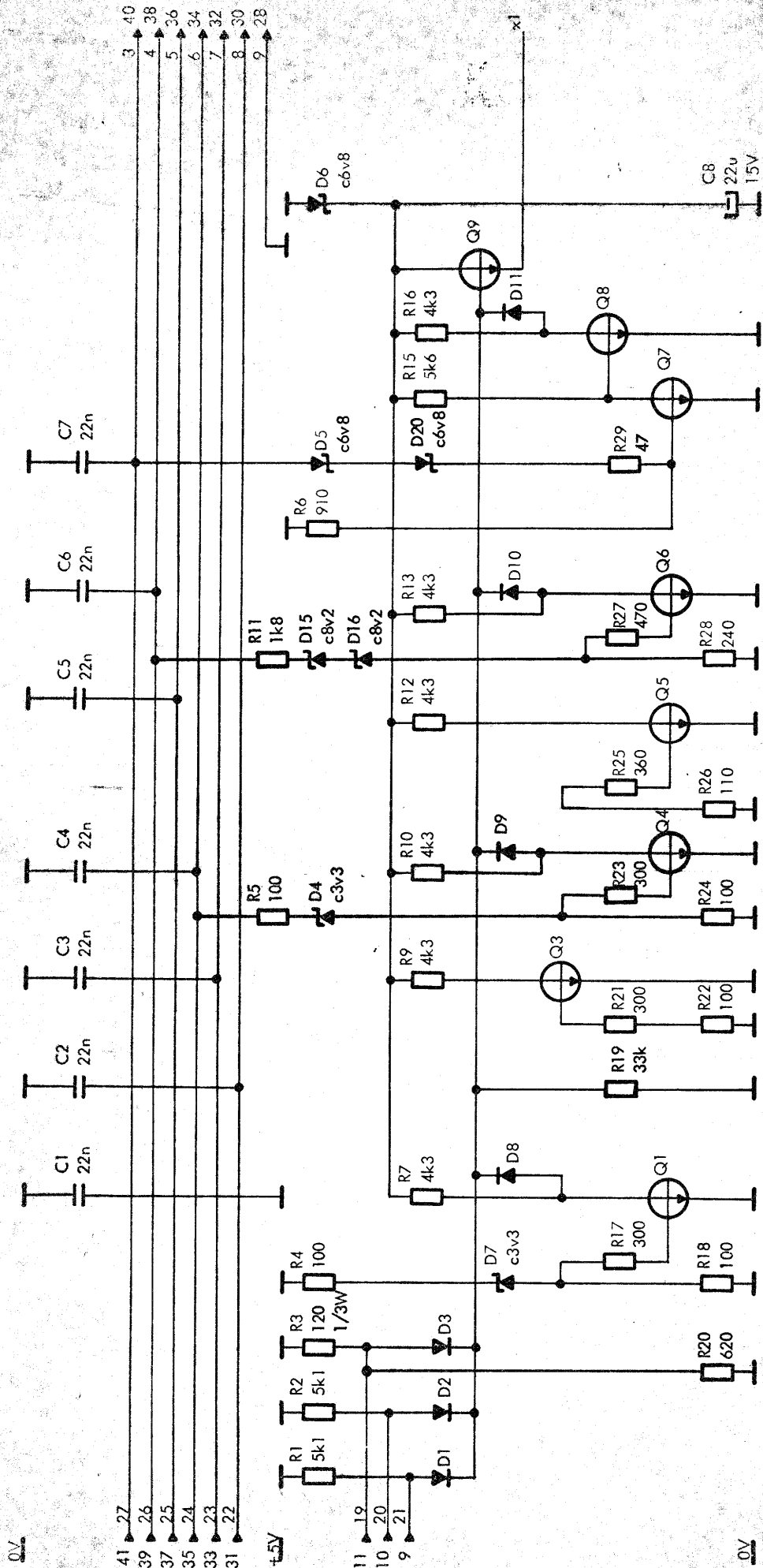

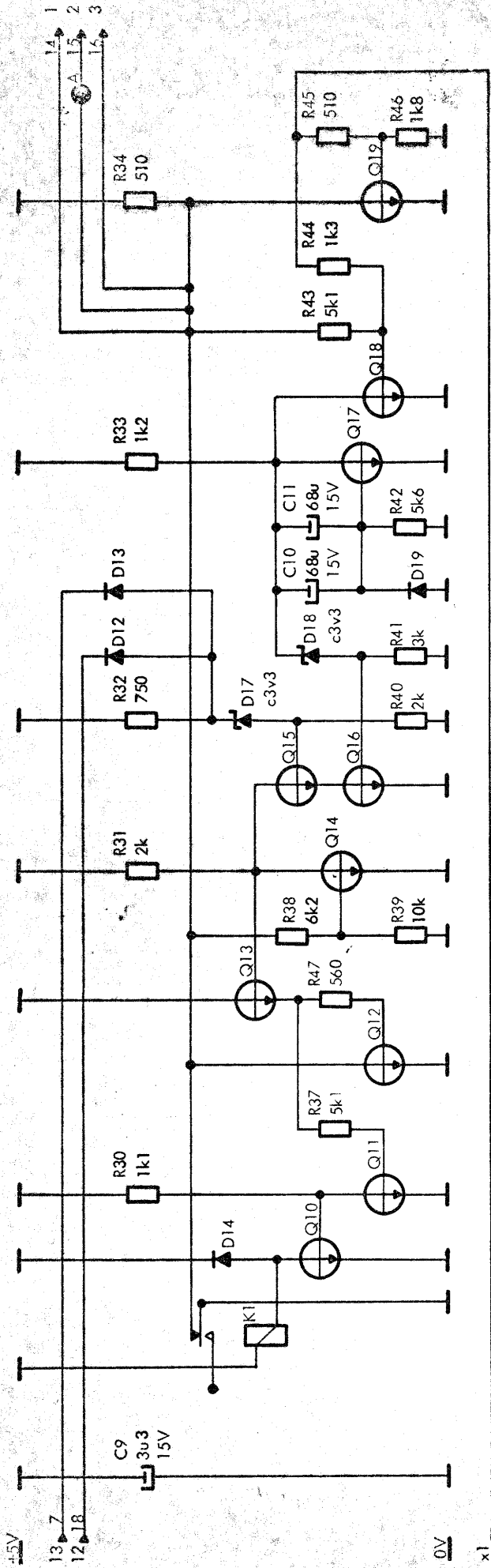

POWER REQUIREMENTS		
+5V	PIN 22	130mA
0V	PIN 21	
POWER DISSIPATION 87.5mW		

Transistors are 2N2369
 Diodes are 1N914
 Zener diodes are 8Z Y88
 Relay ERG MEM01-IRC/G-4V

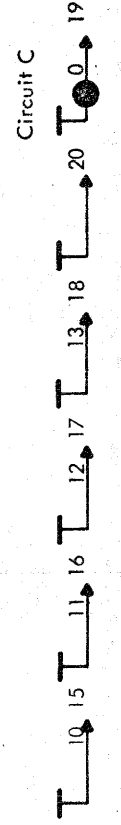
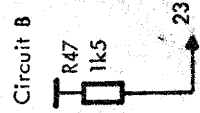

Circuit A

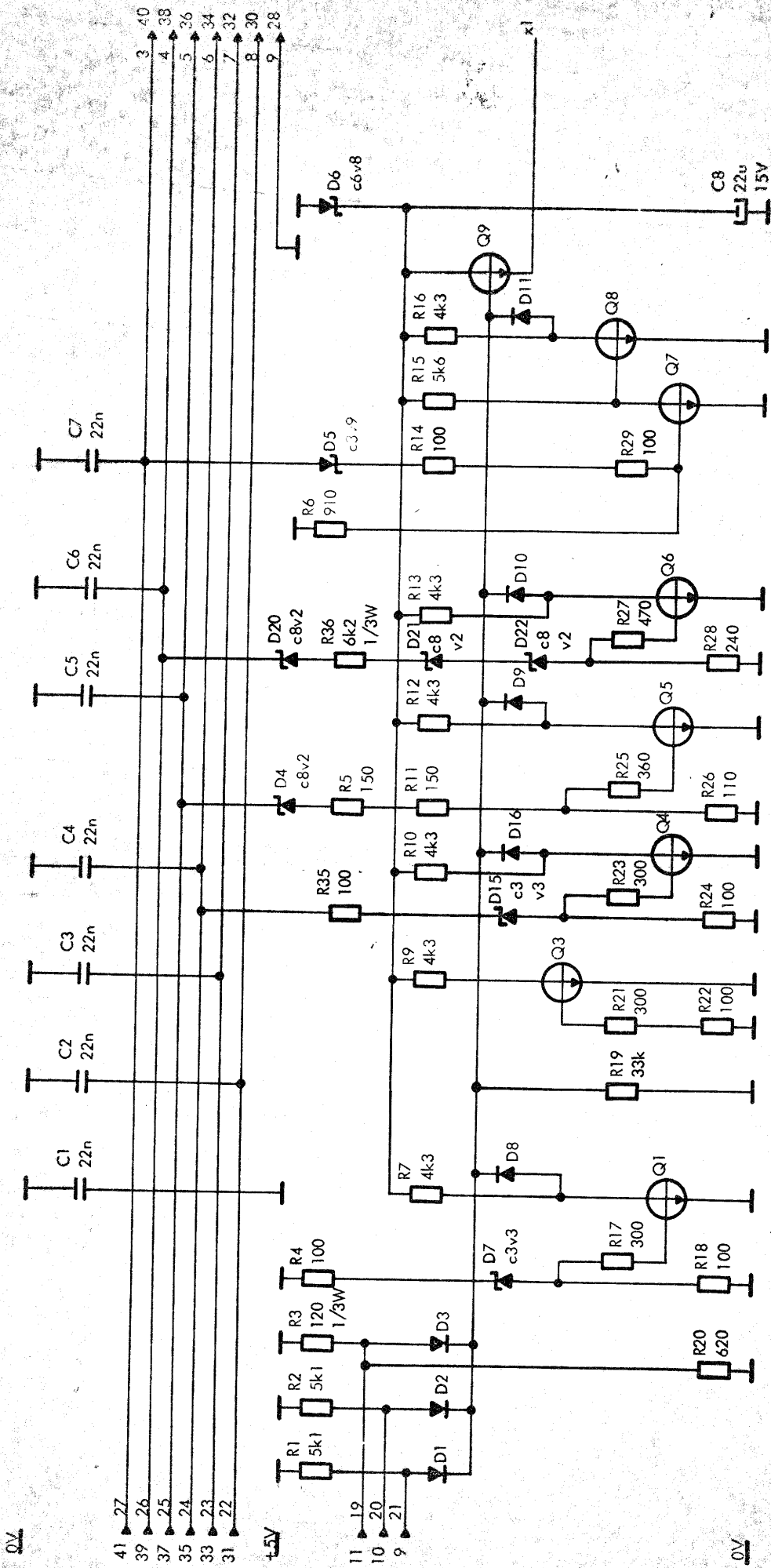

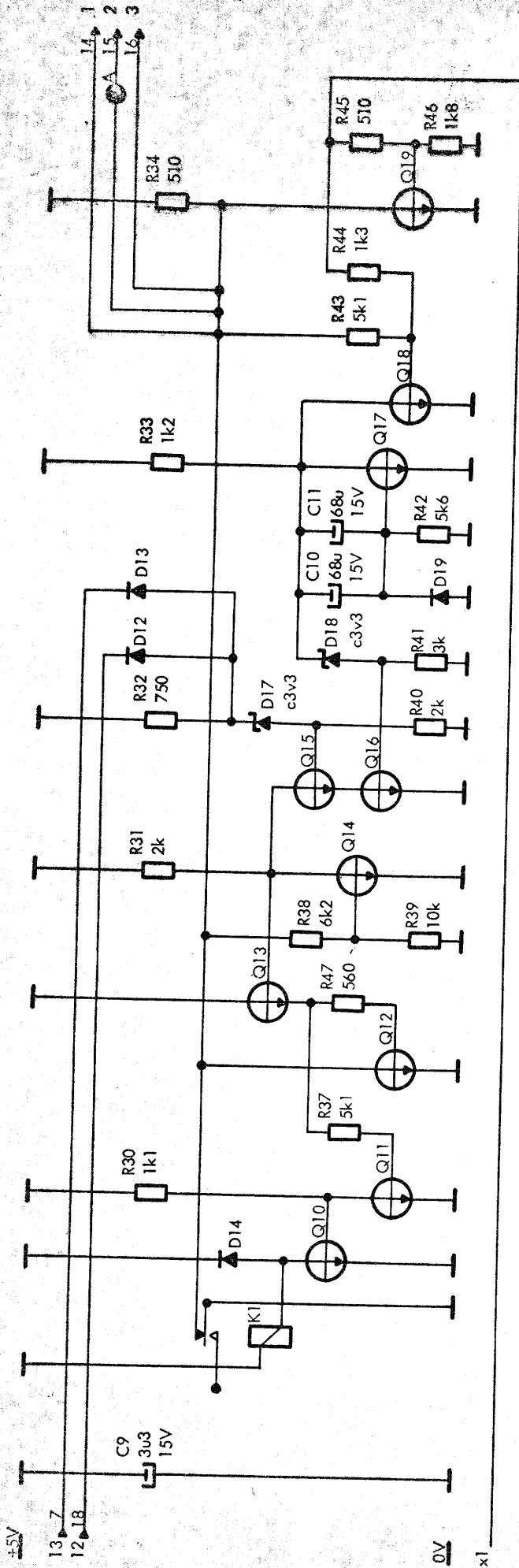

POWER REQUIREMENTS	
+5V	PIN 22 130mA
0V	PIN 21
POWER DISSIPATION 1015mW	

Transistors are 2N2369
 Diodes are 1N914
 Zener diodes are BZY88
 Relay ERG MEM01-IRC/G-4V

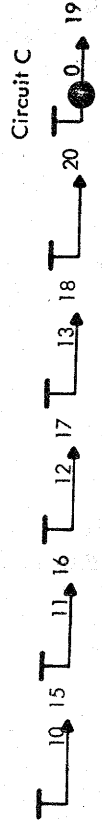
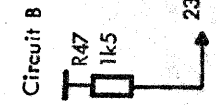

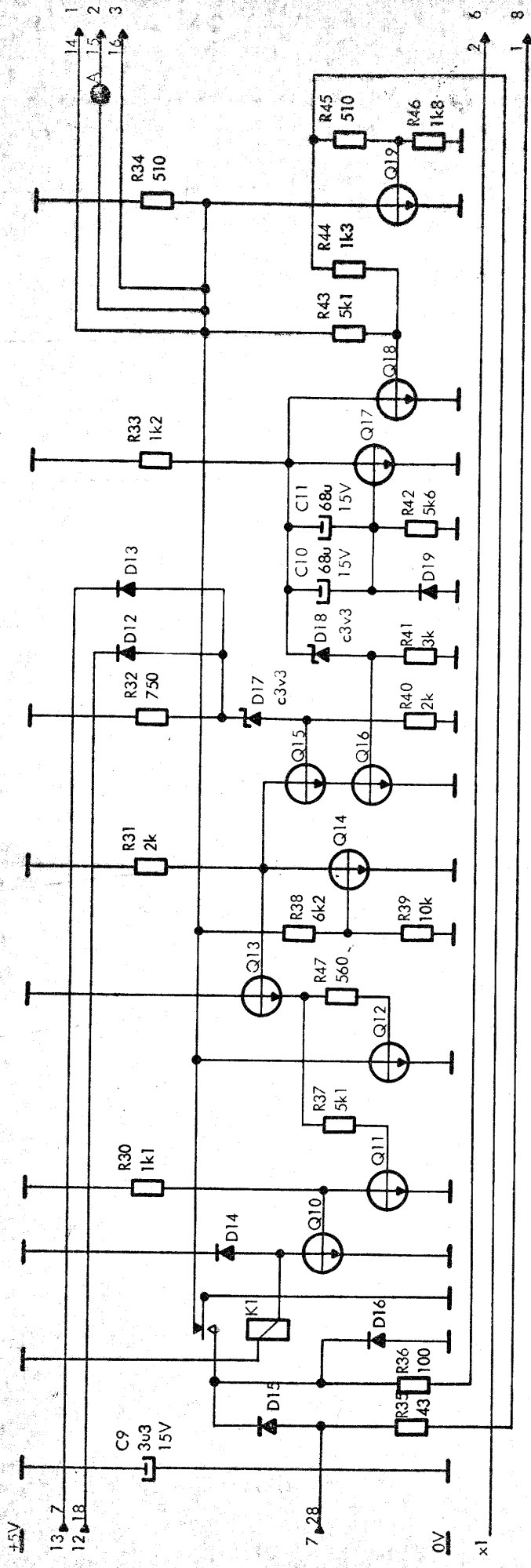

POWER REQUIREMENTS	
+5V	PIN 22 130mA
0V	PIN 21
POWER DISSIPATION 765mW	

Transistors are 2N2369
 Diodes are 1N914
 Zenerdiodes are BZY88
 Relay ERG MEM01-IRC/G-4V

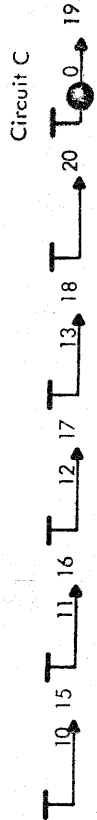
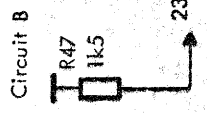

+5V
 0V

1FF403

PCBA Circuit Diagram

RC0323 - 3

p. 2 of 2

Circuit A

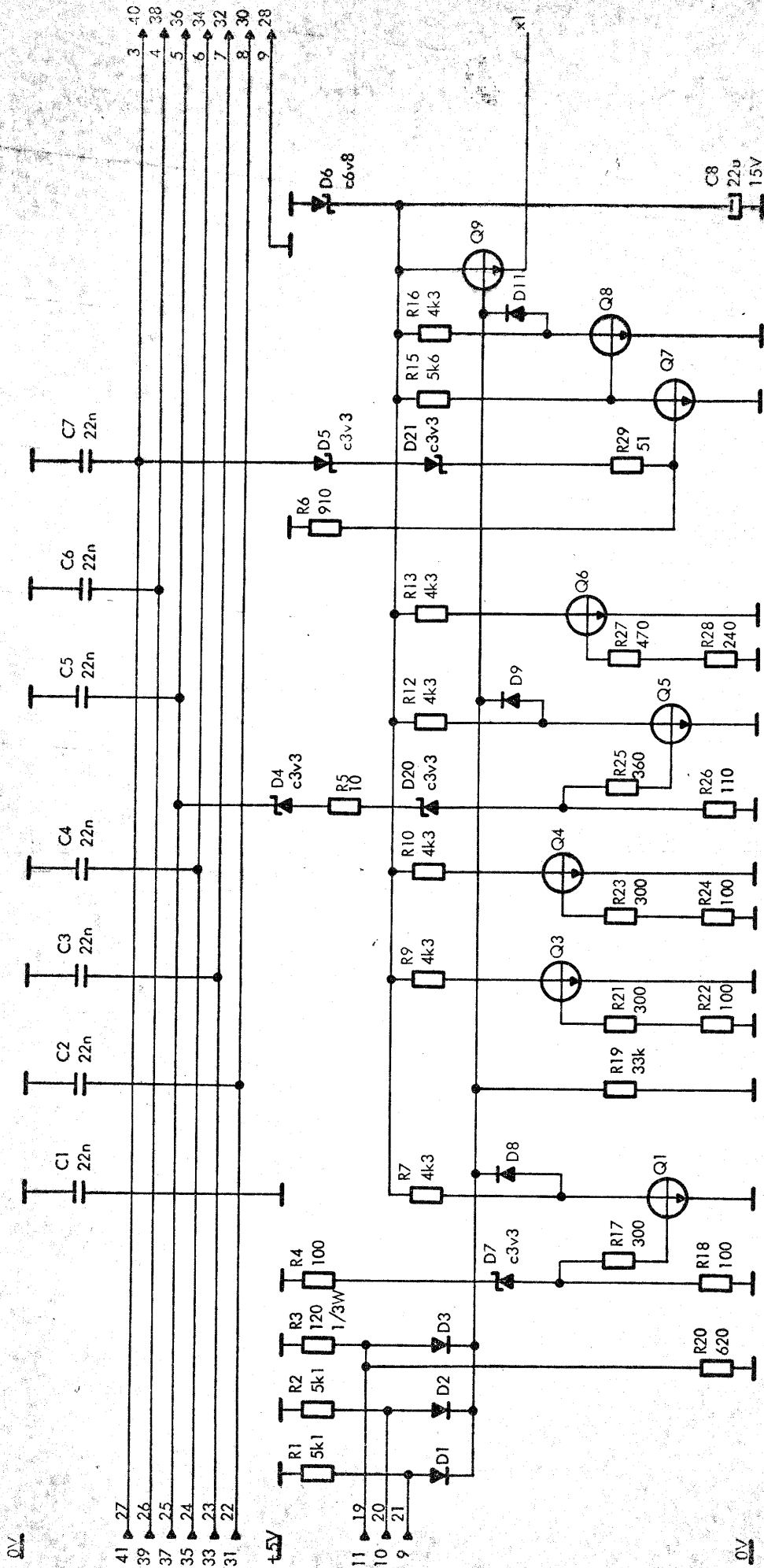

IFF404

PCBA Circuit Diagram

IC0000 - 4

p. 1 of 2

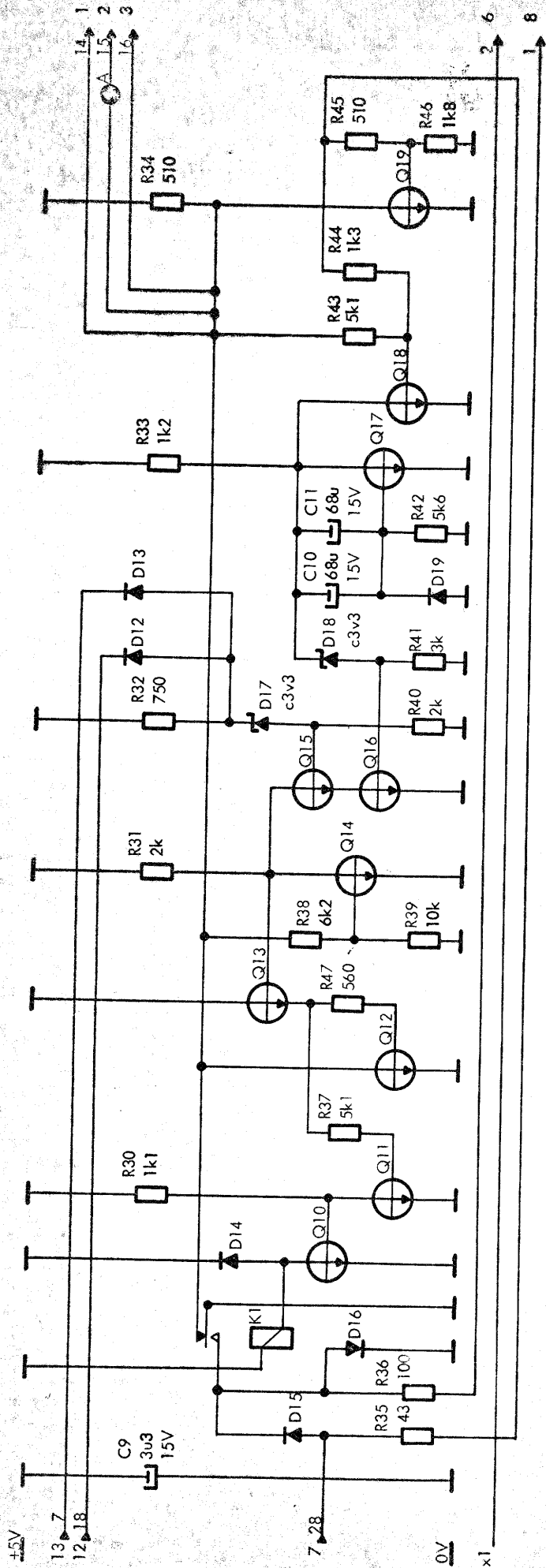

POWER REQUIREMENTS		
+5V	PIN 22	130mA
0V	PIN 21	
POWER DISSIPATION 730mW		

Transistors are 2N2369
 Diodes are 1N914
 Zener diodes are BZY88
 Relay ERG MEM01-IRC/G-4V

+5V
 0V

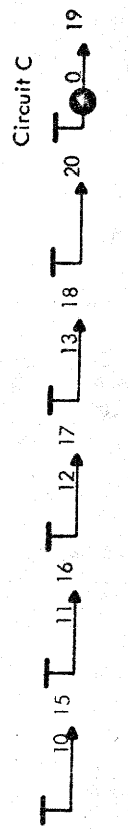
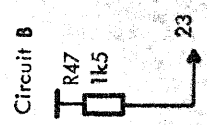

ECN: 14097
 Drawn by: 280570ML
 Design Check: 200771 PEP
 Replaces Dwg. No.:
 Approved by:

Circuit A

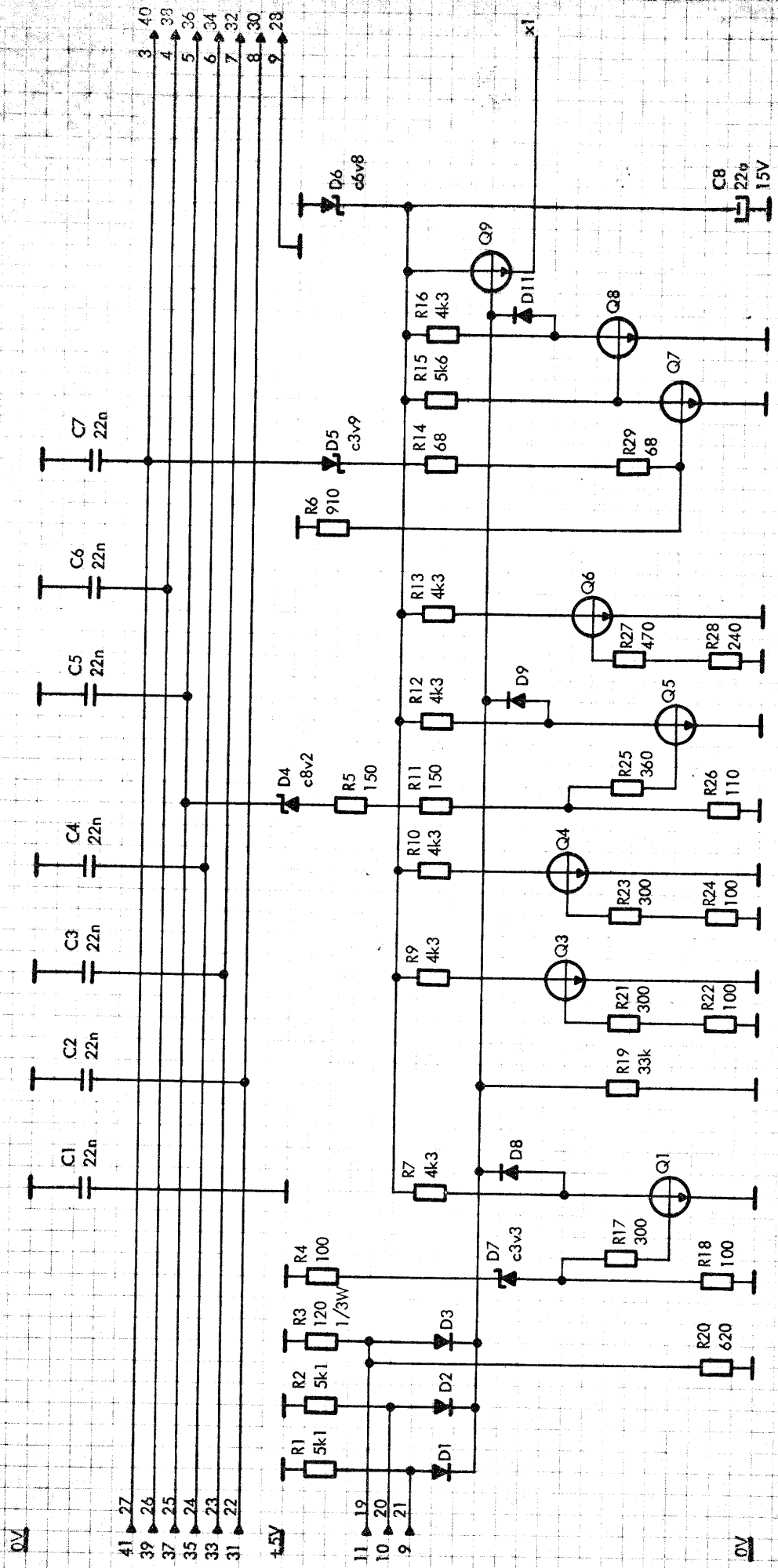

1000000
 111779

1FF405
 PCBA Circuit Diagram

R0003 - 5
 p. 1 of 2

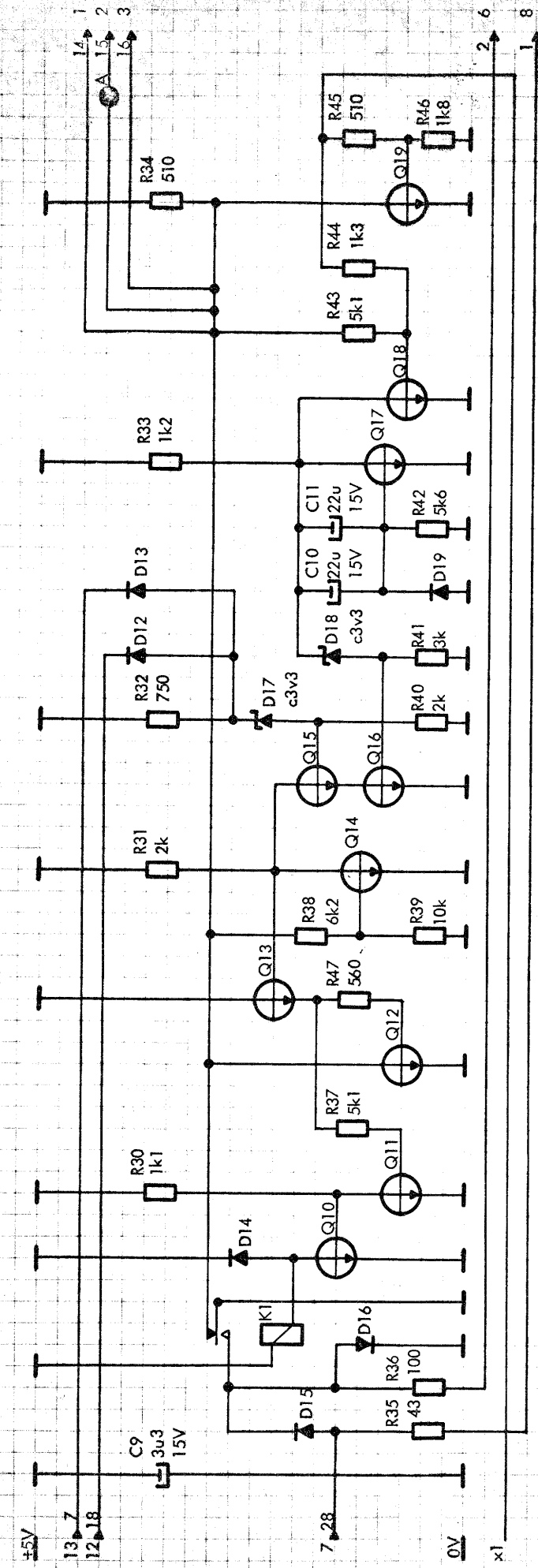

POWER REQUIREMENTS	
+5V	PIN 22 130mA
0V	PIN 21
POWER DISSIPATION 765mW	

Transistors are 2N2369
 Diodes are 1N914
 Zener diodes are BZY88
 Relay ERG MEM01-IRC/G-4V

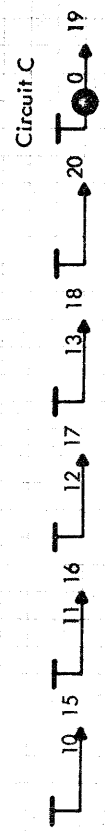
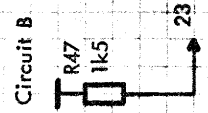

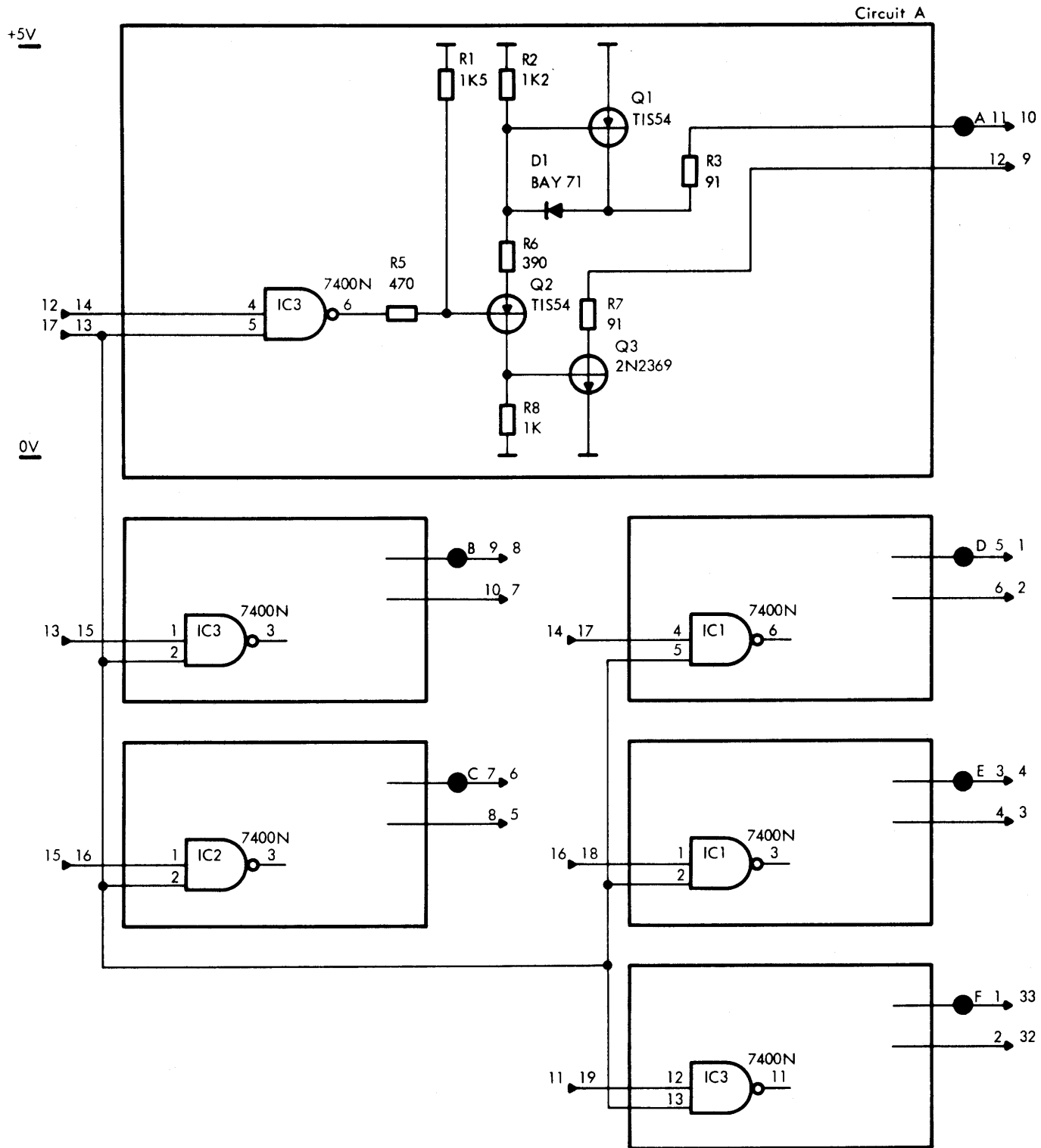

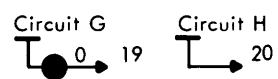
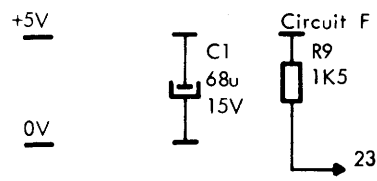
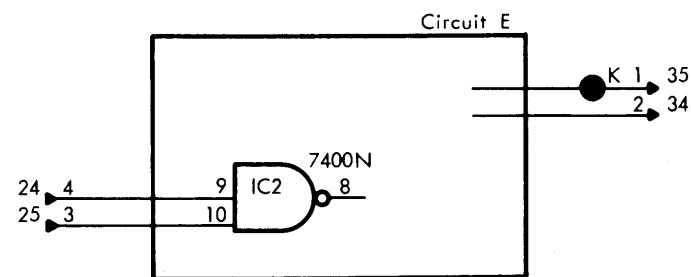
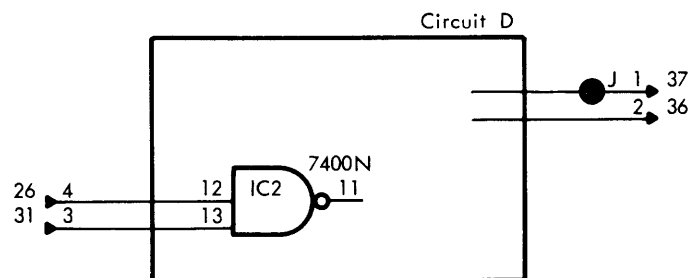
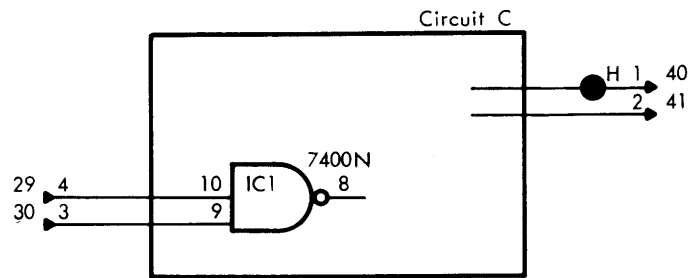
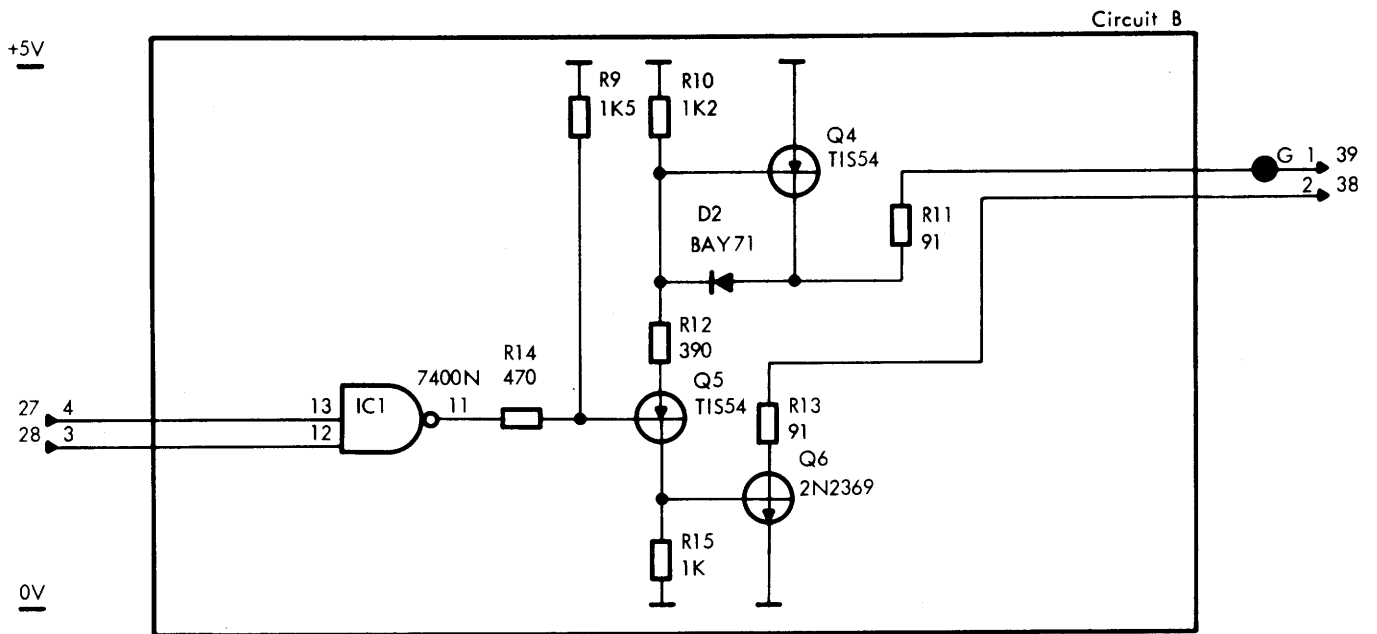

POWER REQUIREMENTS		
+5V	PIN 22	269 mA
0V	PIN 21	
POWER DISSIPATION 1420 mW		

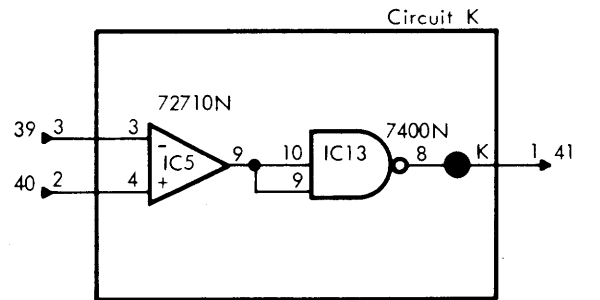
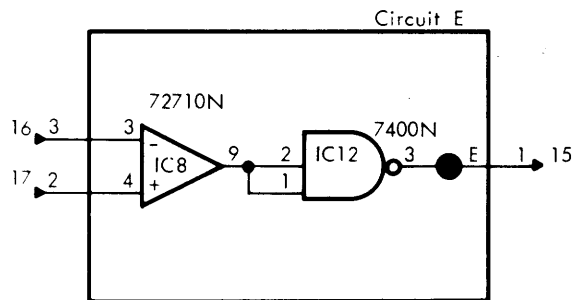
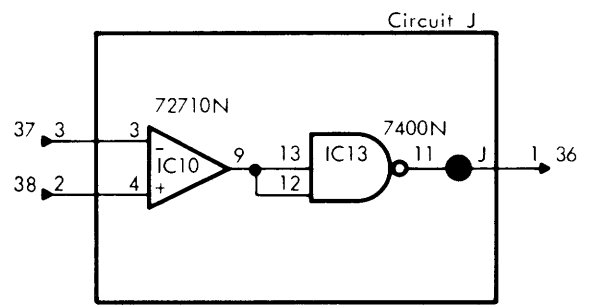
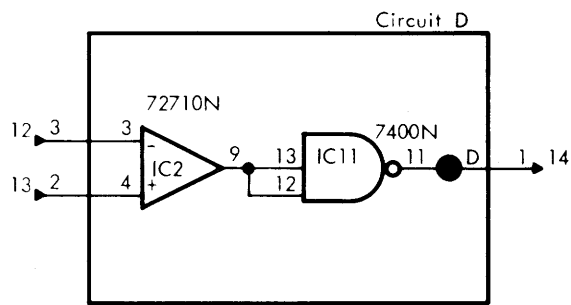
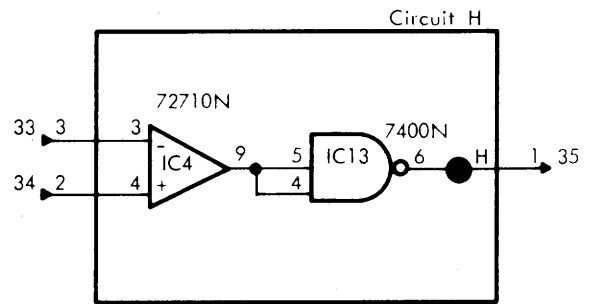
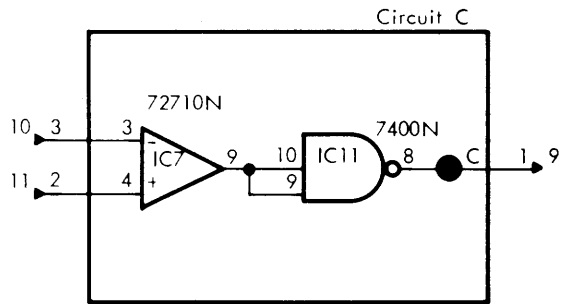
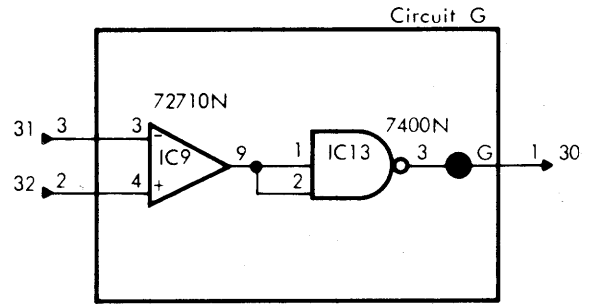
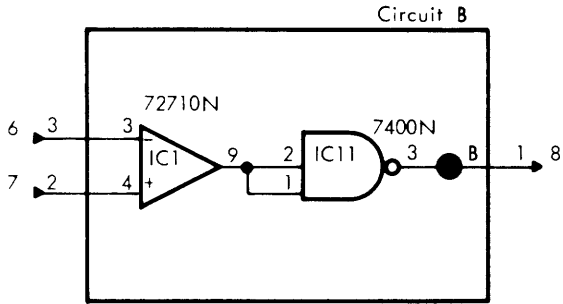
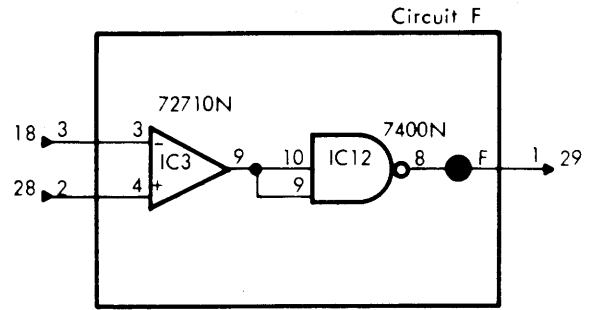
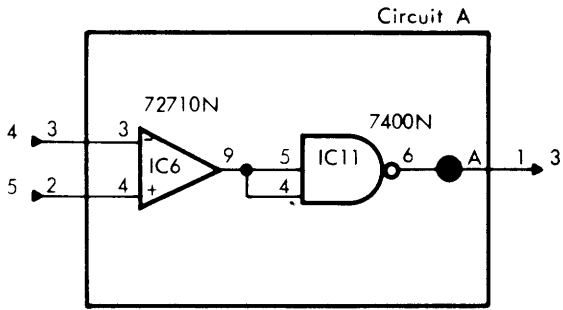

+12V
+5V
-6V
0V

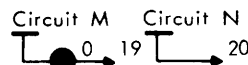
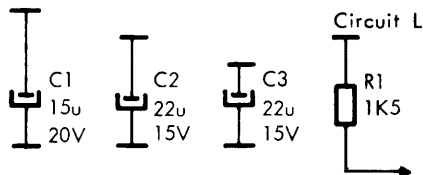

POWER REQUIREMENTS		
+12 V	PIN 1	90 mA
+ 5 V	PIN 22	40 mA
0 V	PIN 21	
- 6 V	PIN 2	70 mA
POWER DISSIPATION 1800 mW		

Circuit A

+5V

0V

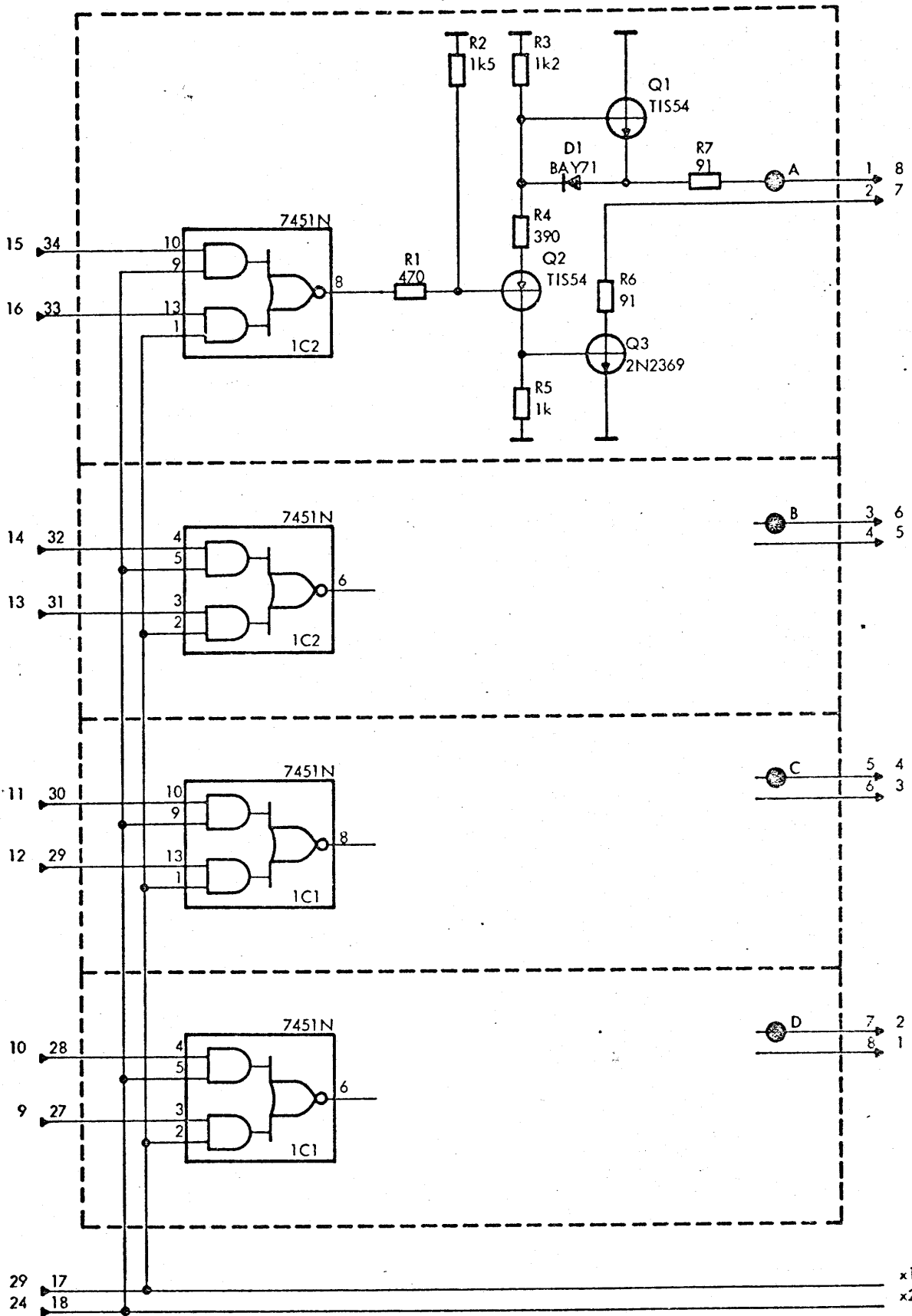

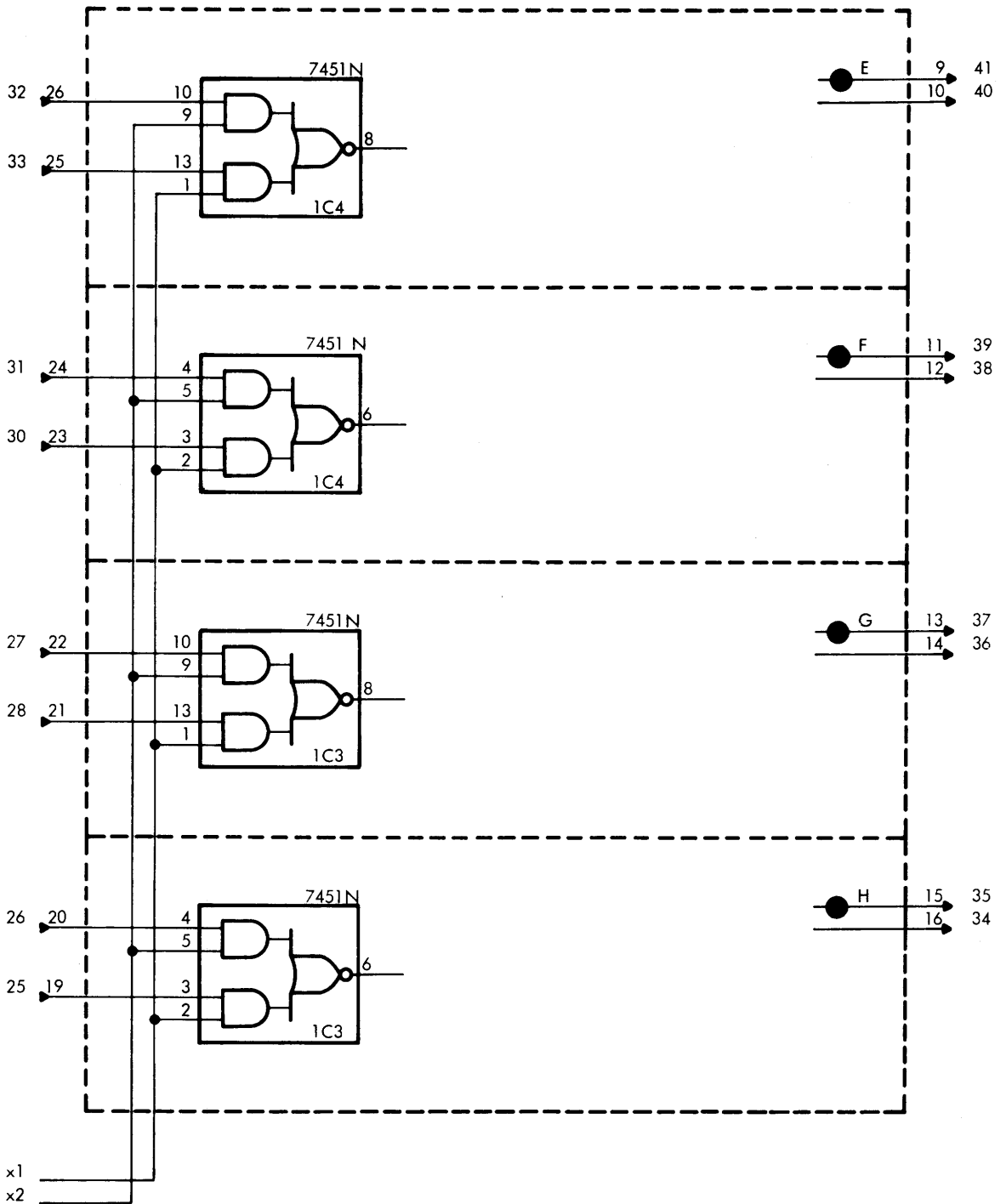

+5V

0V

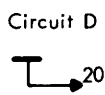
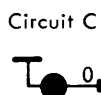
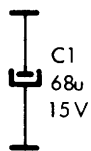

POWER REQUIREMENTS		
+5V	PIN 22	215mA
0V	PIN 21	
POWER DISSIPATION 1150mW		

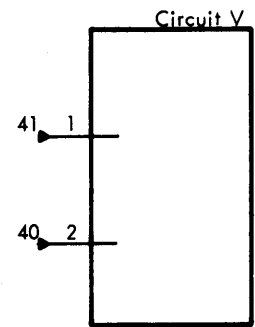
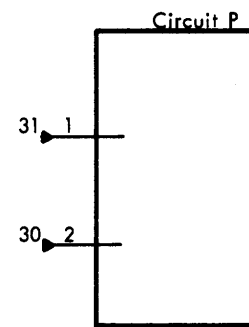
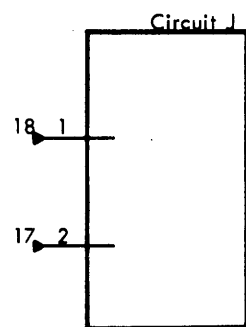
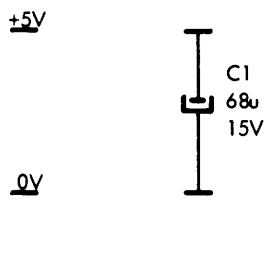
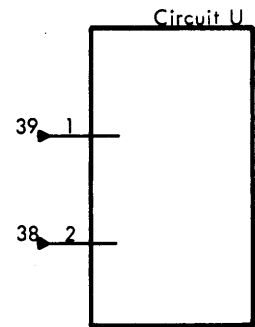
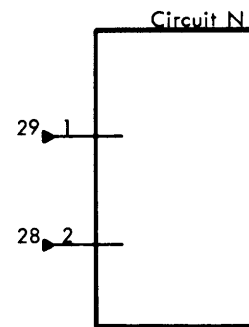
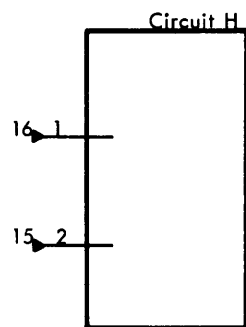
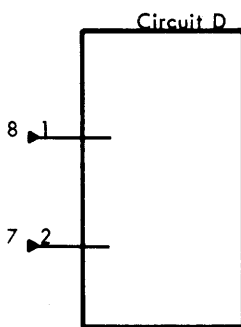
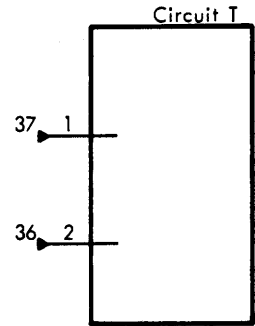
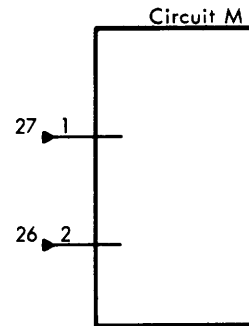
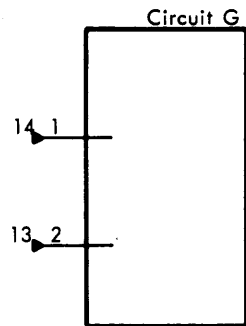
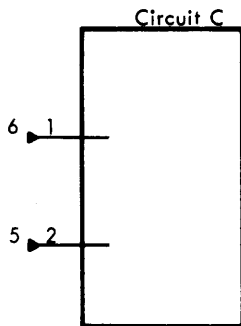
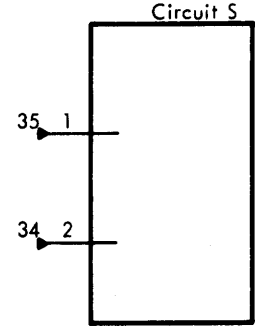
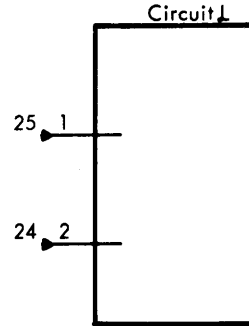
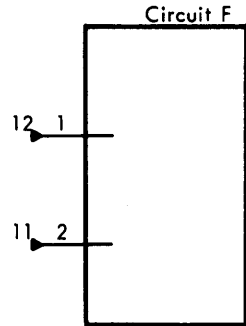
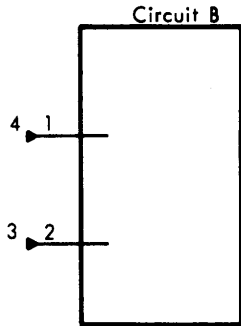
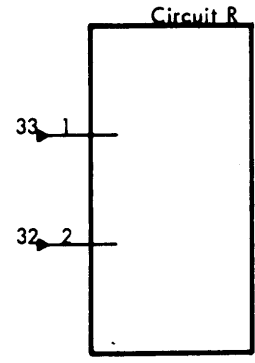
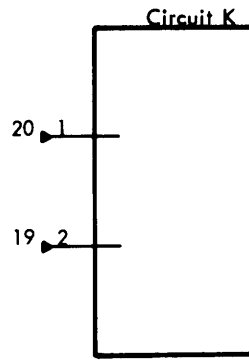
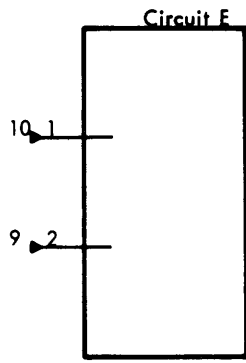
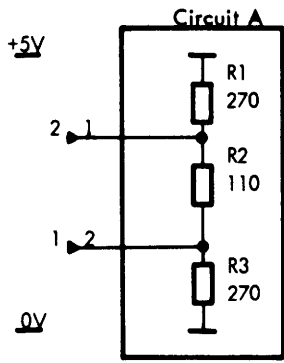

POWER REQUIREMENTS		
+5V	PIN 22	204mA
0V	PIN 21	
POWER DISSIPATION 1070mW		

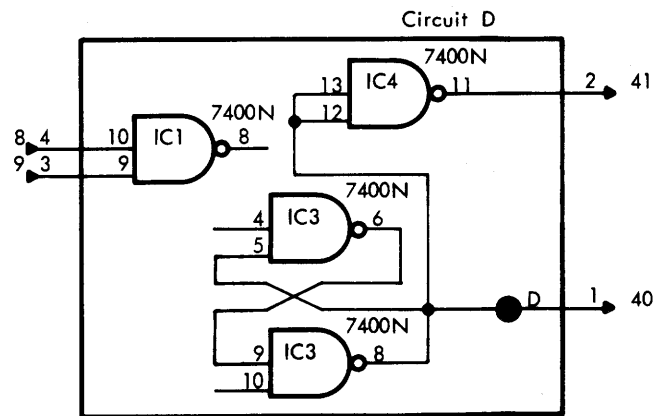
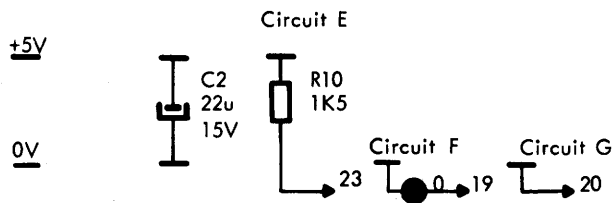
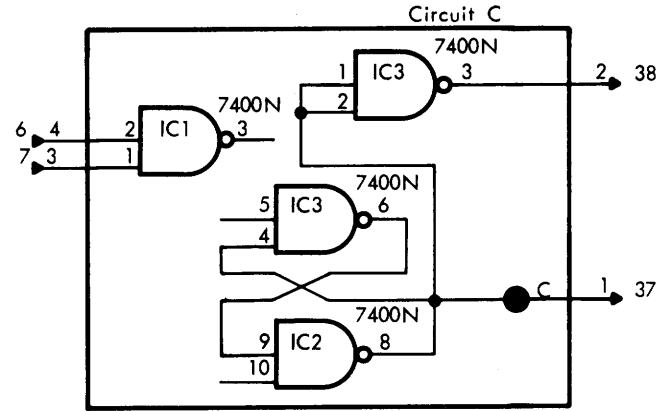
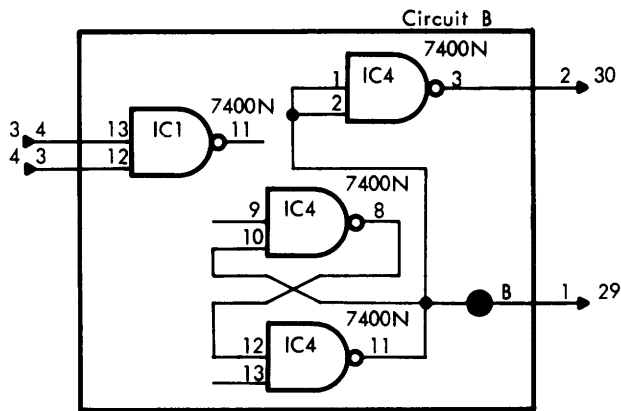
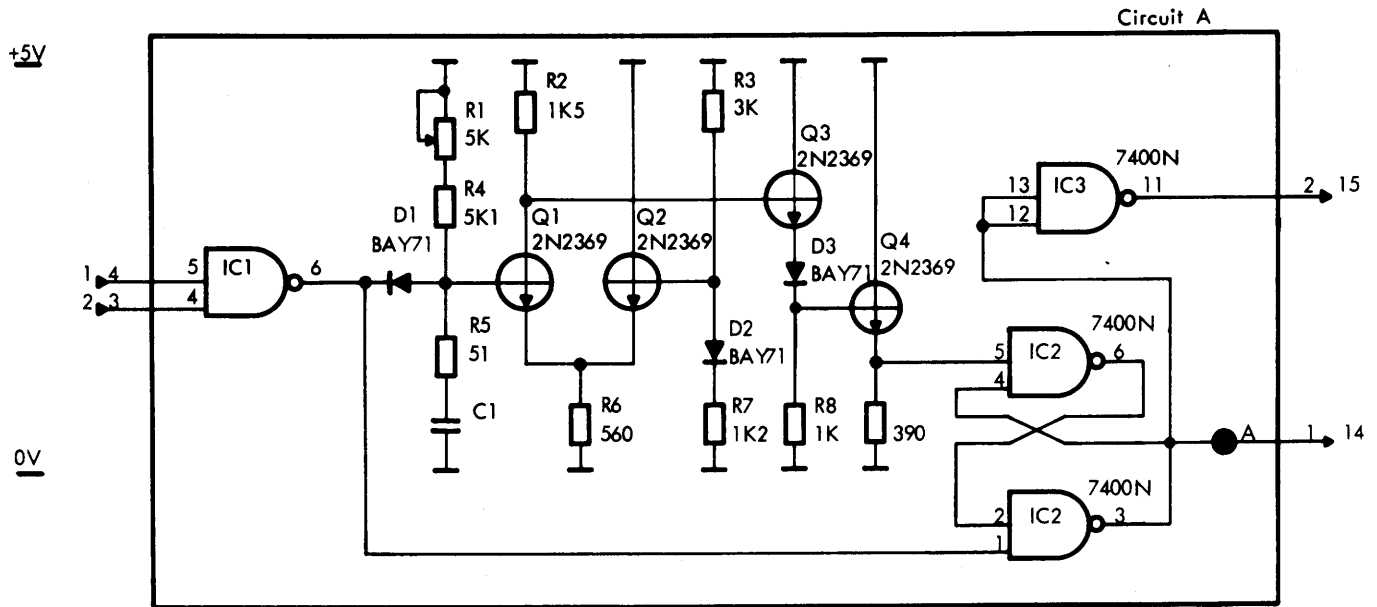

POWER REQUIREMENTS		
+5V	PIN 22	110mA
0V	PIN 21	
POWER DISSIPATION 575 mW		

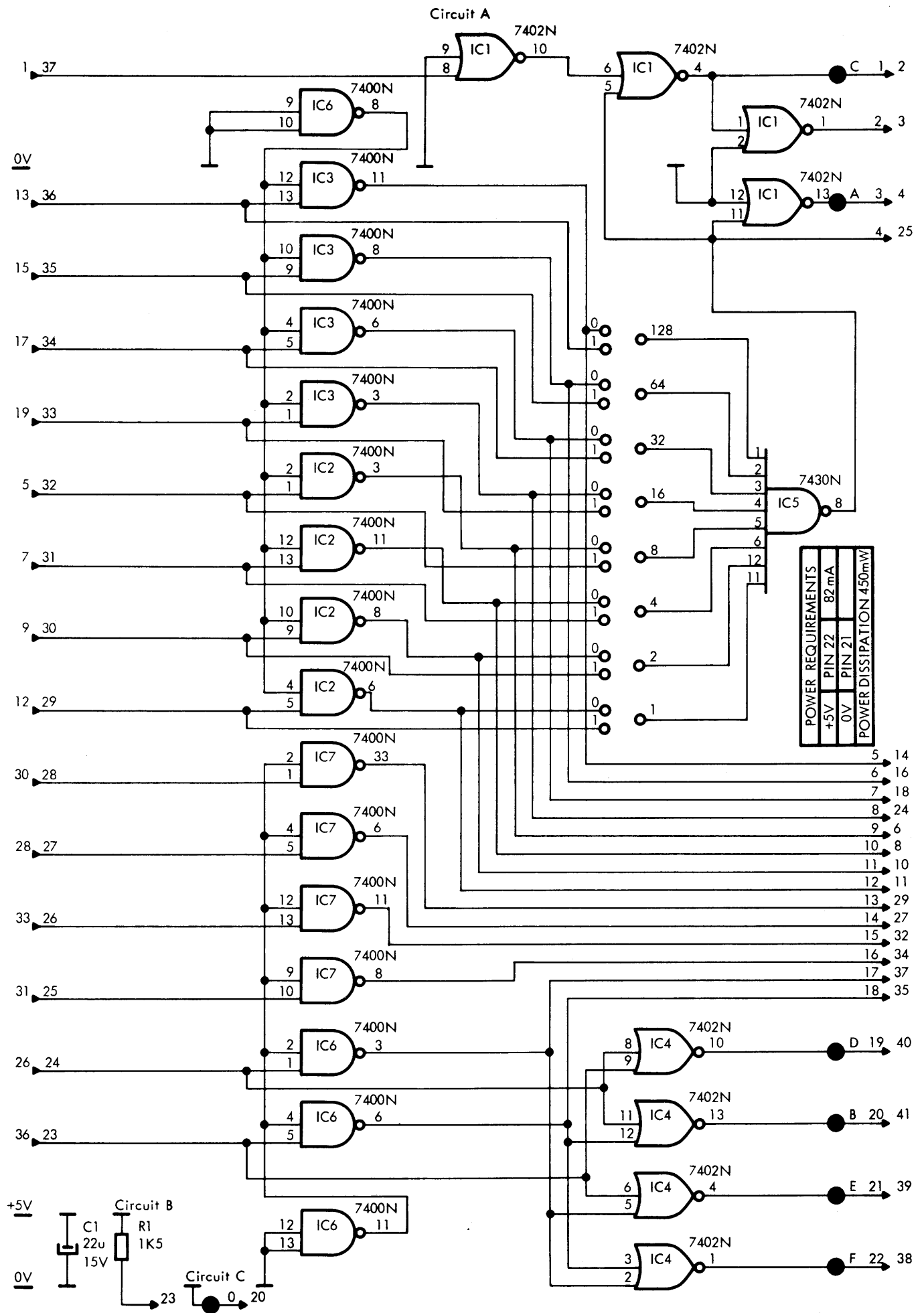

Circuit A

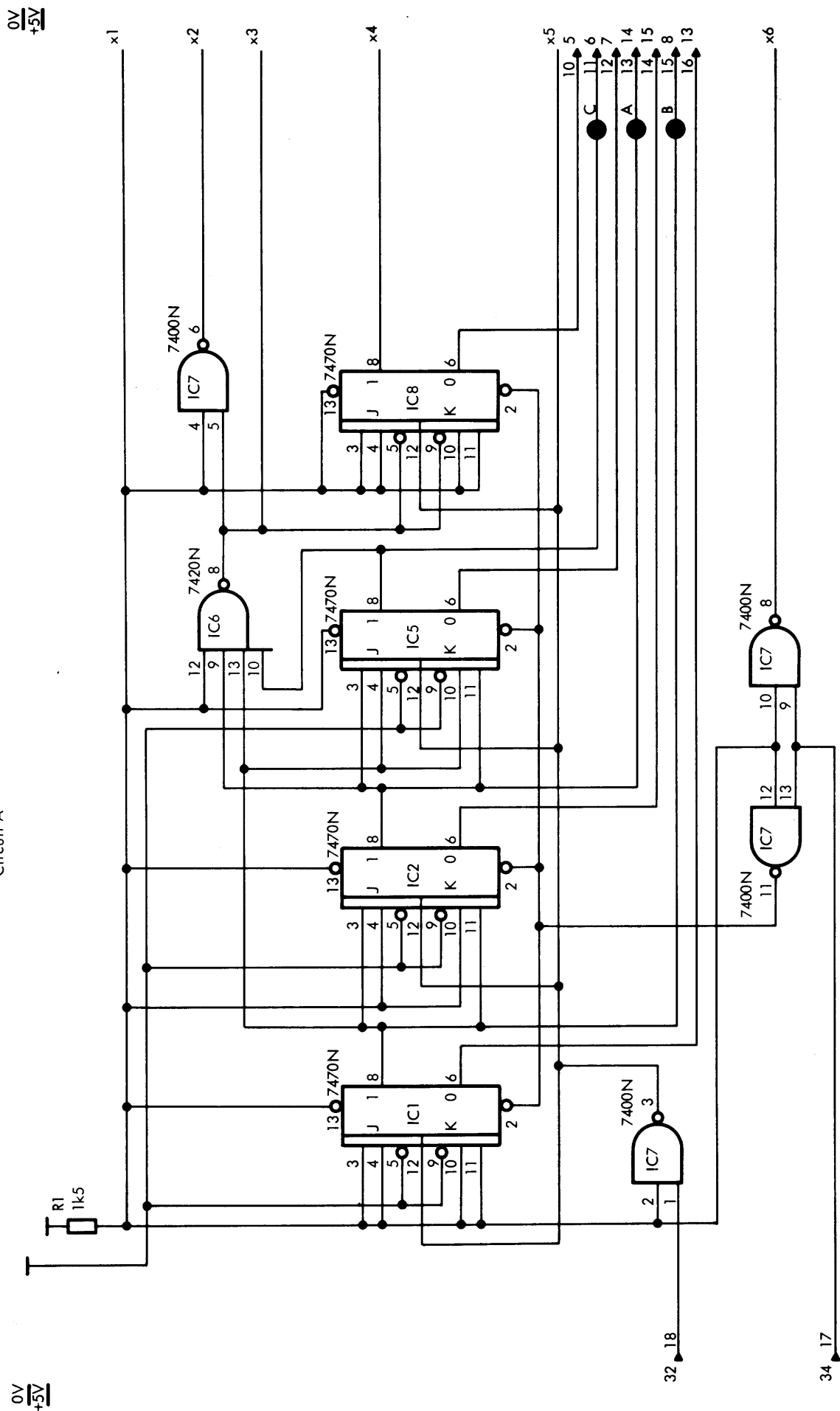

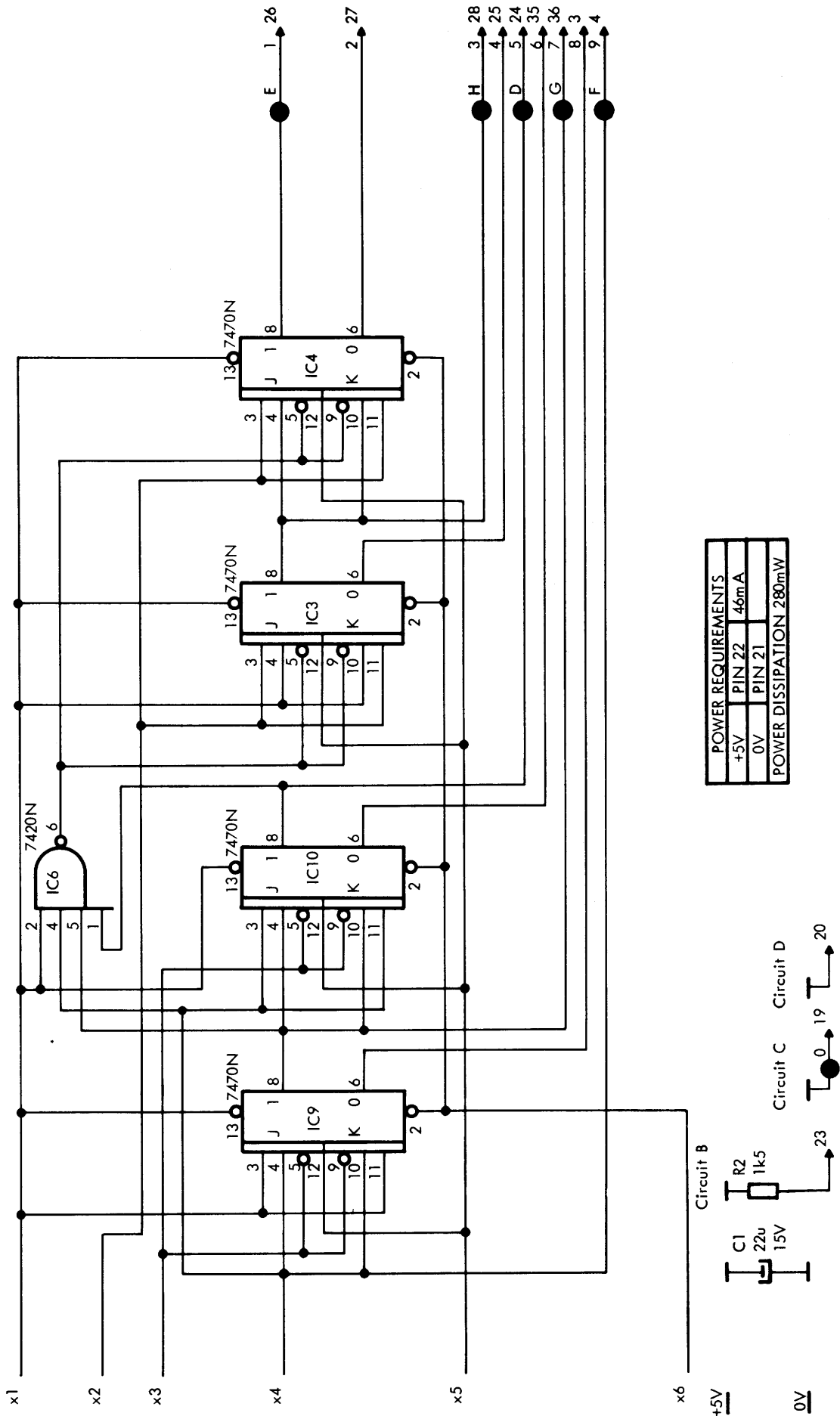

POWER REQUIREMENTS	
+5V	PIN 22 46mA
0V	PIN 21
POWER DISSIPATION 280mW	

Circuit A
1AJ407

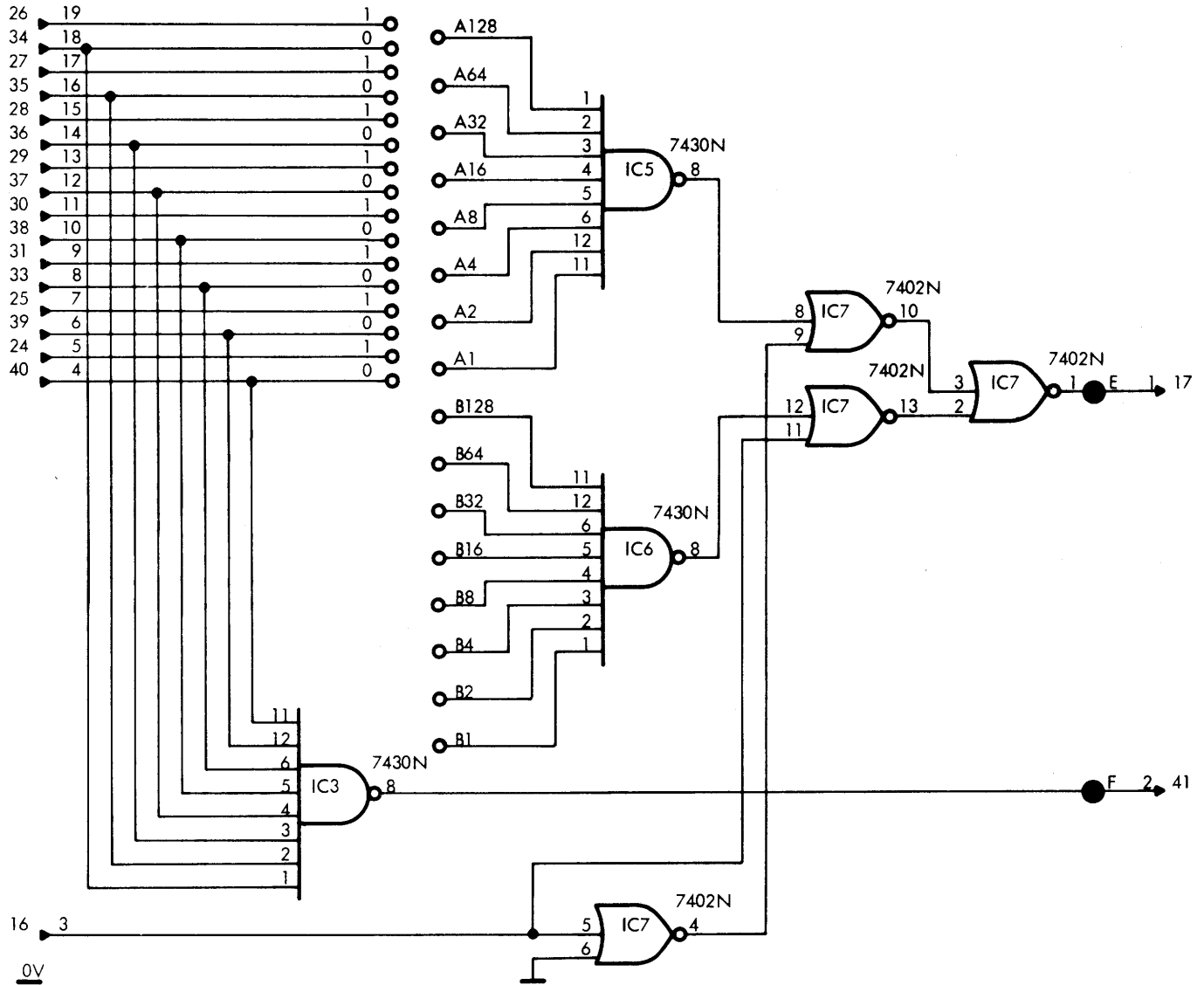

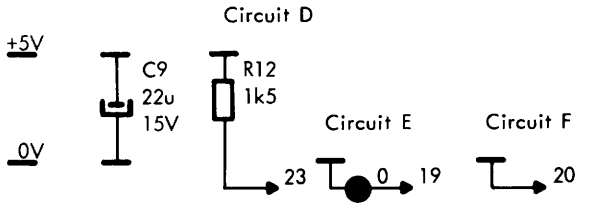
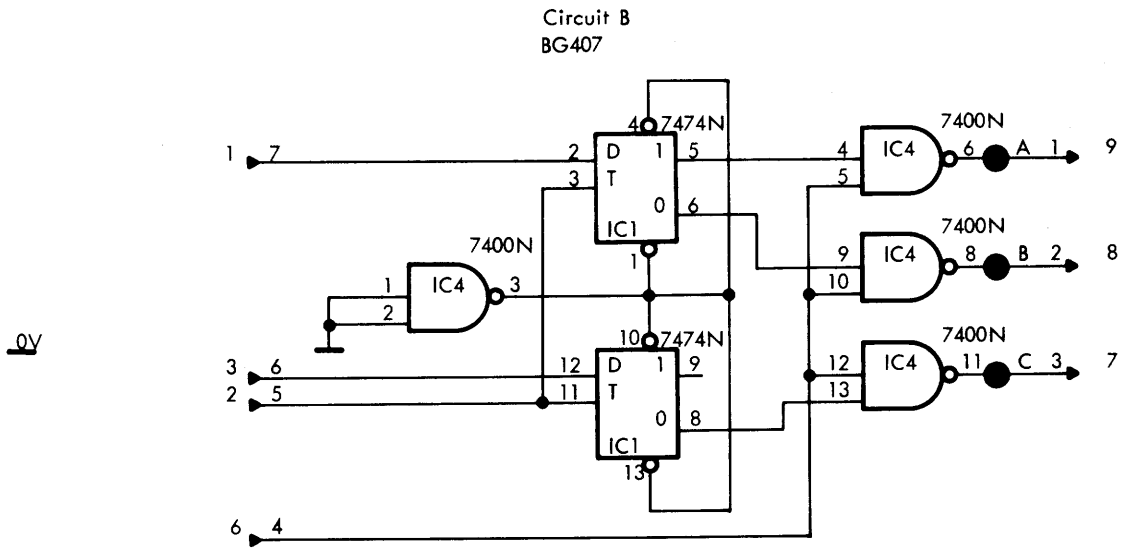
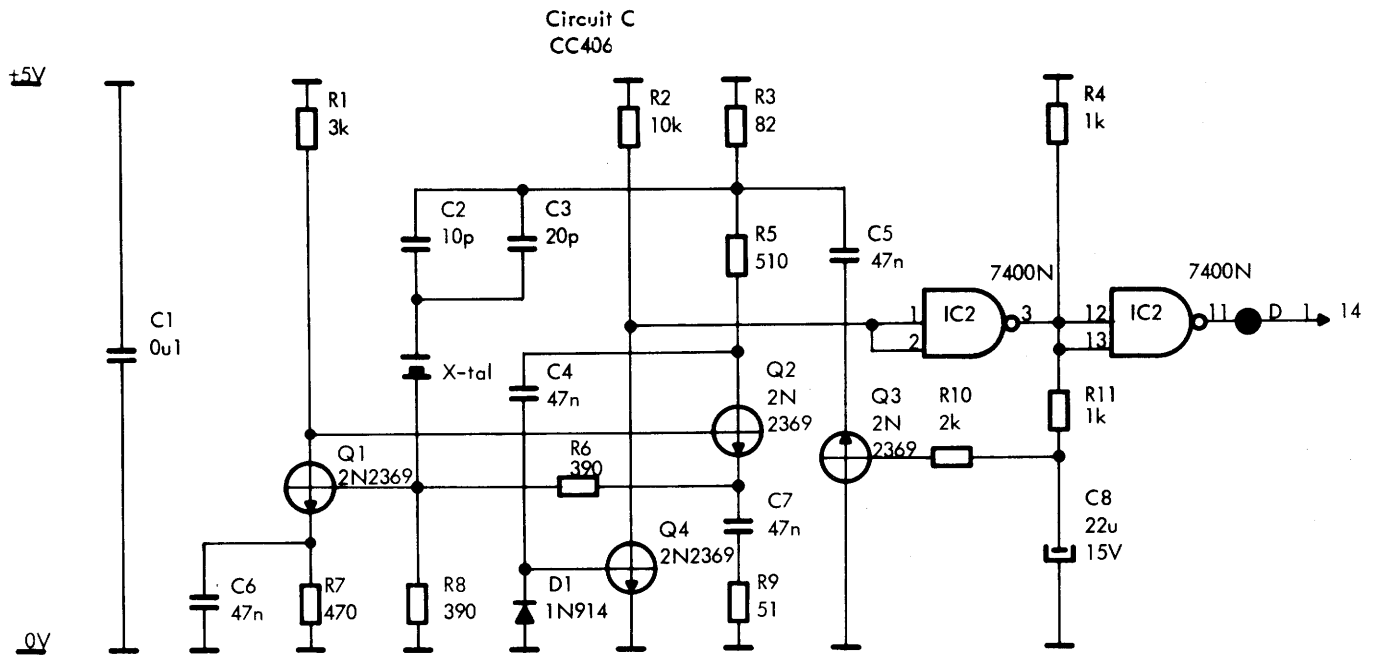

POWER REQUIREMENTS		
+5V	PIN 22	75mA
0V	PIN 21	
POWER DISSIPATION 455mW		

X-tal: Cathodeon
2M- 1 β Mc/s - As.
Holder: H6 - 6/U

+24V
+12V

0V

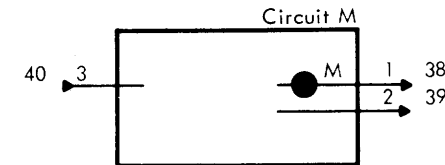
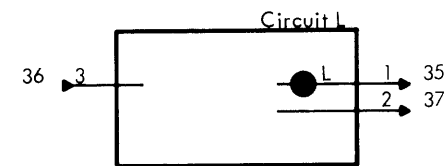
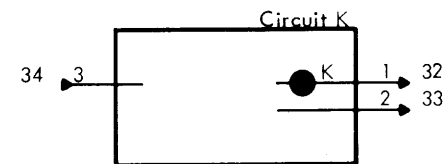
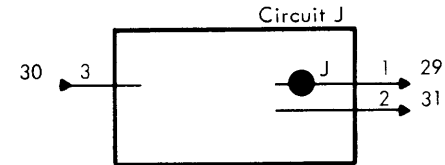
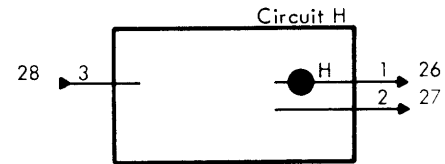
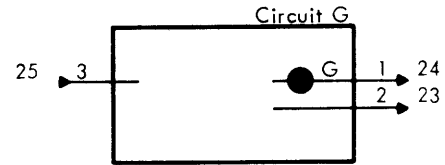
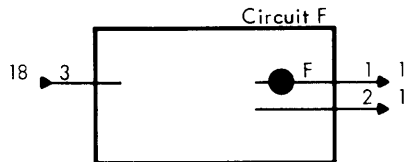
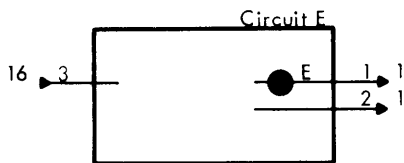
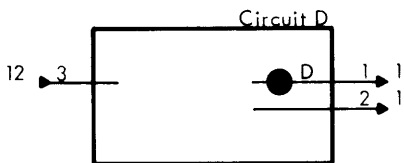
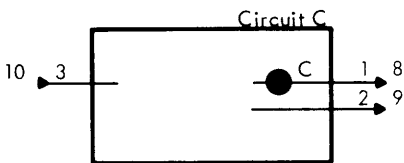
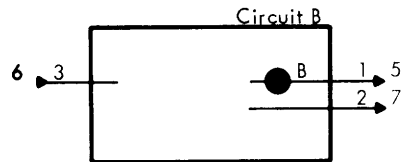
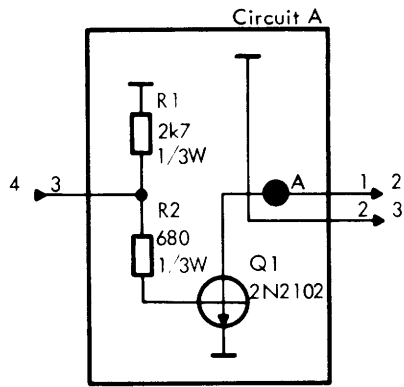

+12V

0V

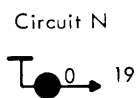
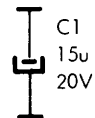

POWER REQUIREMENTS		
+24V	PIN 41	400mA
+12V	PIN 1	55mA
0V	PIN 21	
POWER DISSIPATION 660mW		

0V
-6V

0V
-6V

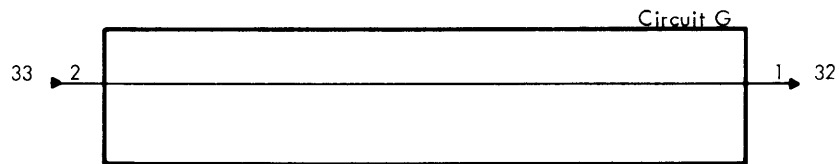
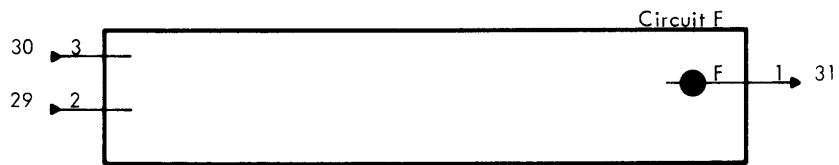
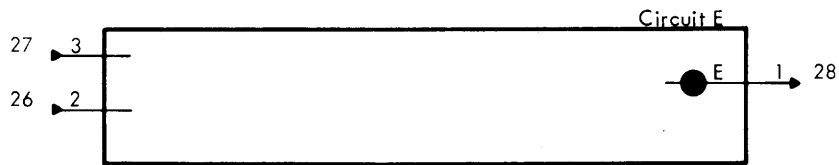
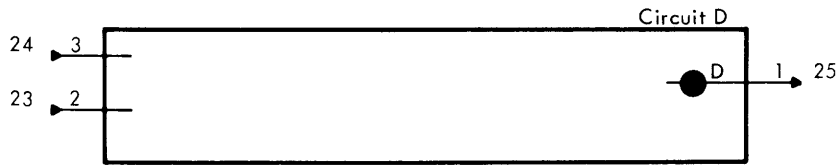
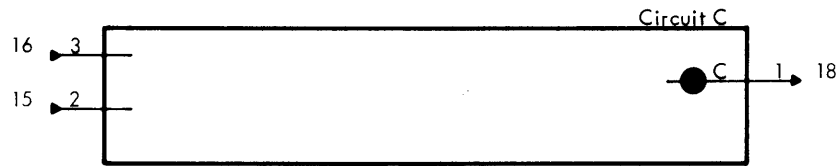
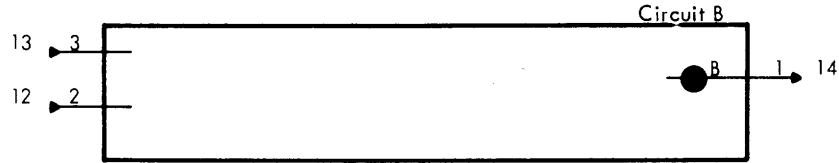
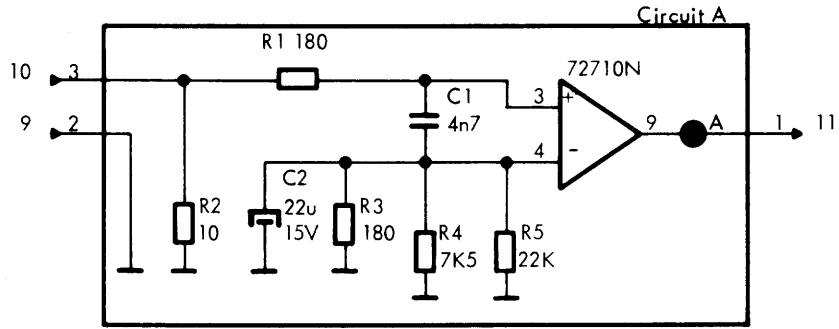

+12V

0V

-6V

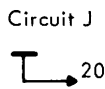
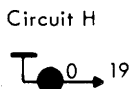
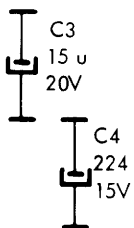

POWER REQUIREMENTS		
+12V	PIN 1	54 mA
0V	PIN 21	
-6V	PIN 2	48 mA
POWER DISSIPATION 1W		

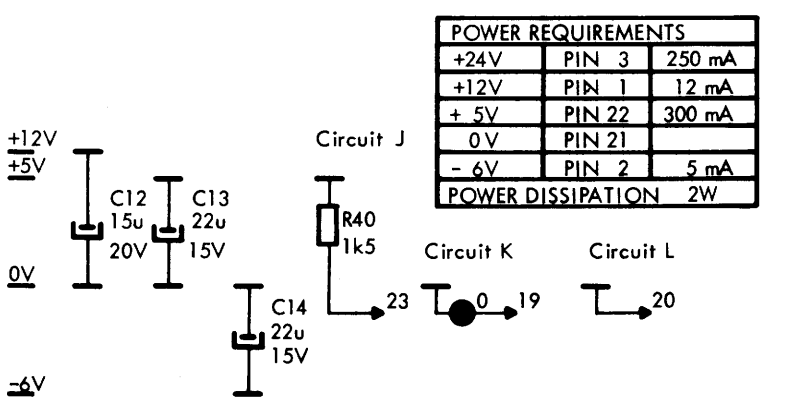
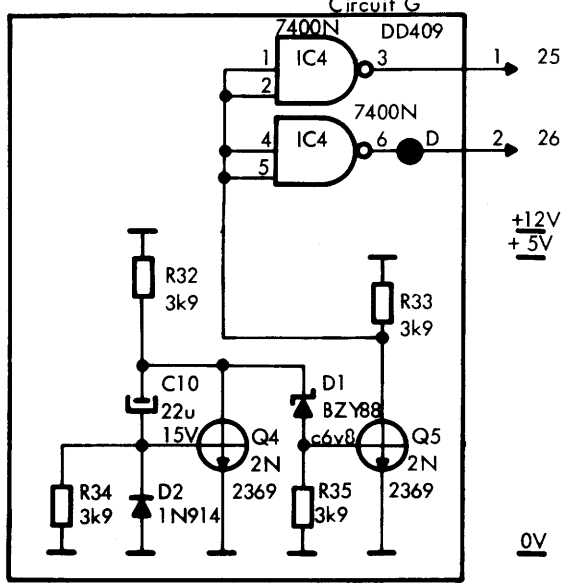
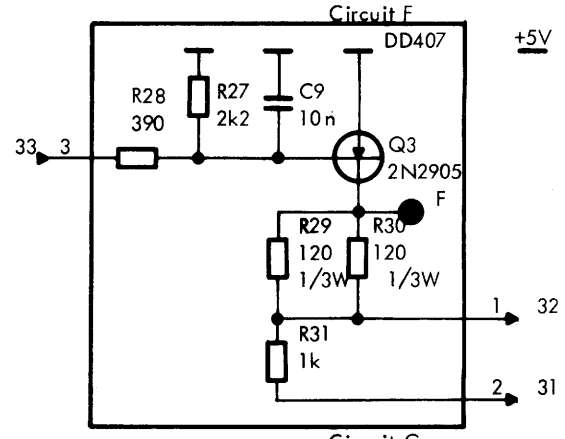
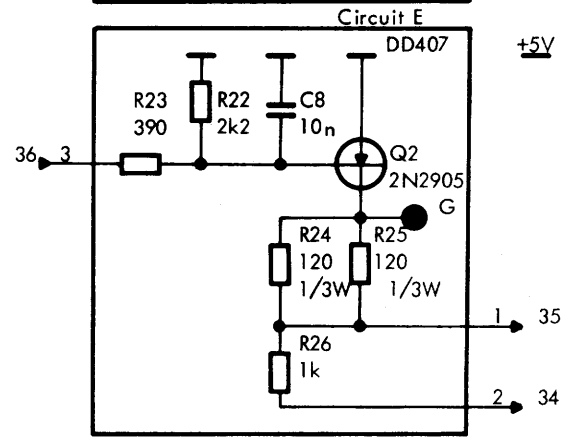
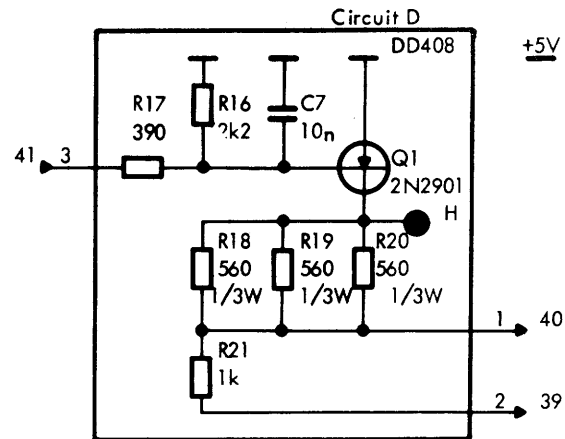
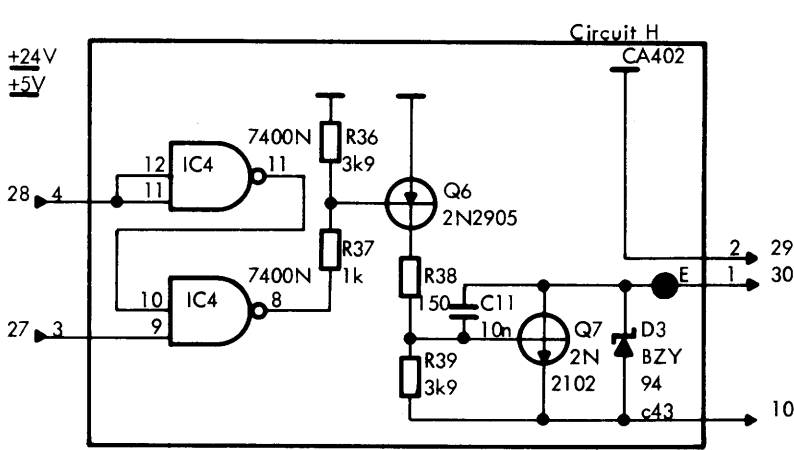
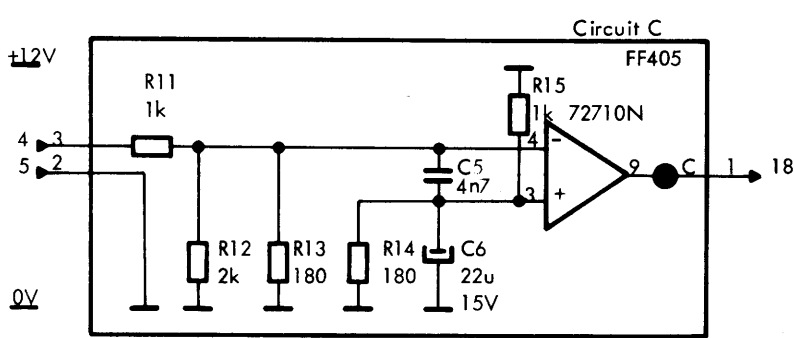
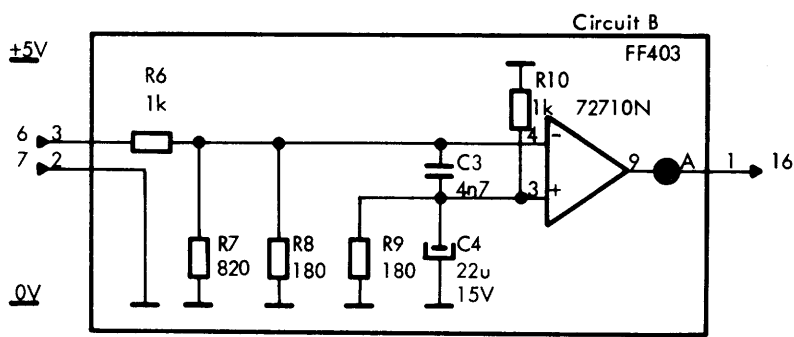
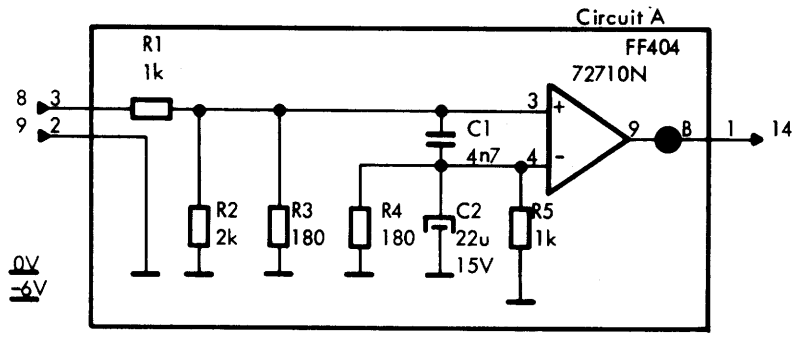

POWER REQUIREMENTS			
+24V	PIN 3	250 mA	
+12V	PIN 1	12 mA	
+ 5V	PIN 22	300 mA	
0V	PIN 21		
- 6V	PIN 2	5 mA	
POWER DISSIPATION 2W			

Unit
Dwg. No.
V21041

+5V, +12V & -6V REG
PCBA Circuit Diagram

RC0908-1

pl of 3p

Circuit A

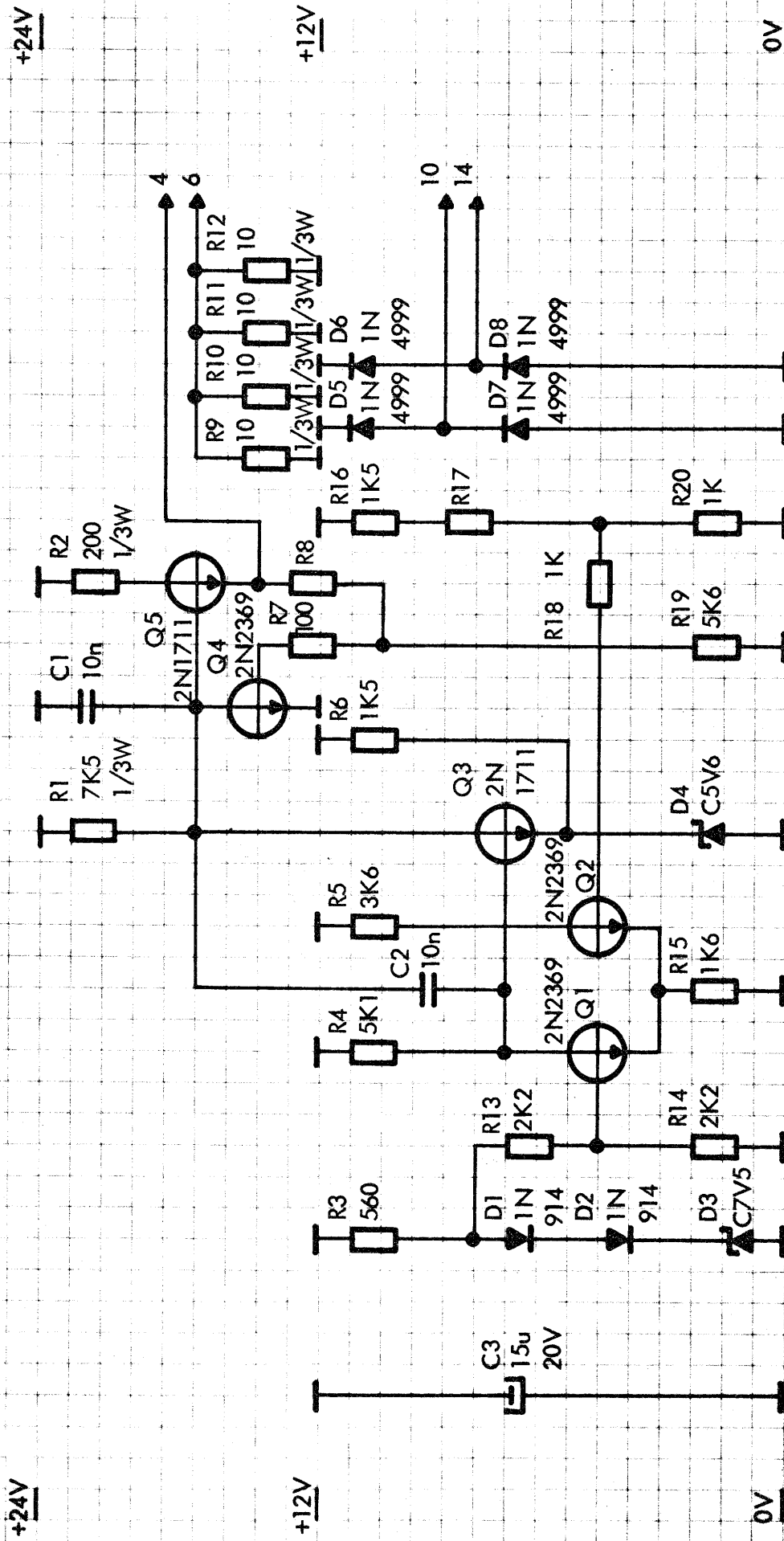

Unit

Dwg. No.

V21042

+5V, +12V & -6V REG

PCBA Circuit Diagram

RC0908-1

p2 of 3p

Circuit A

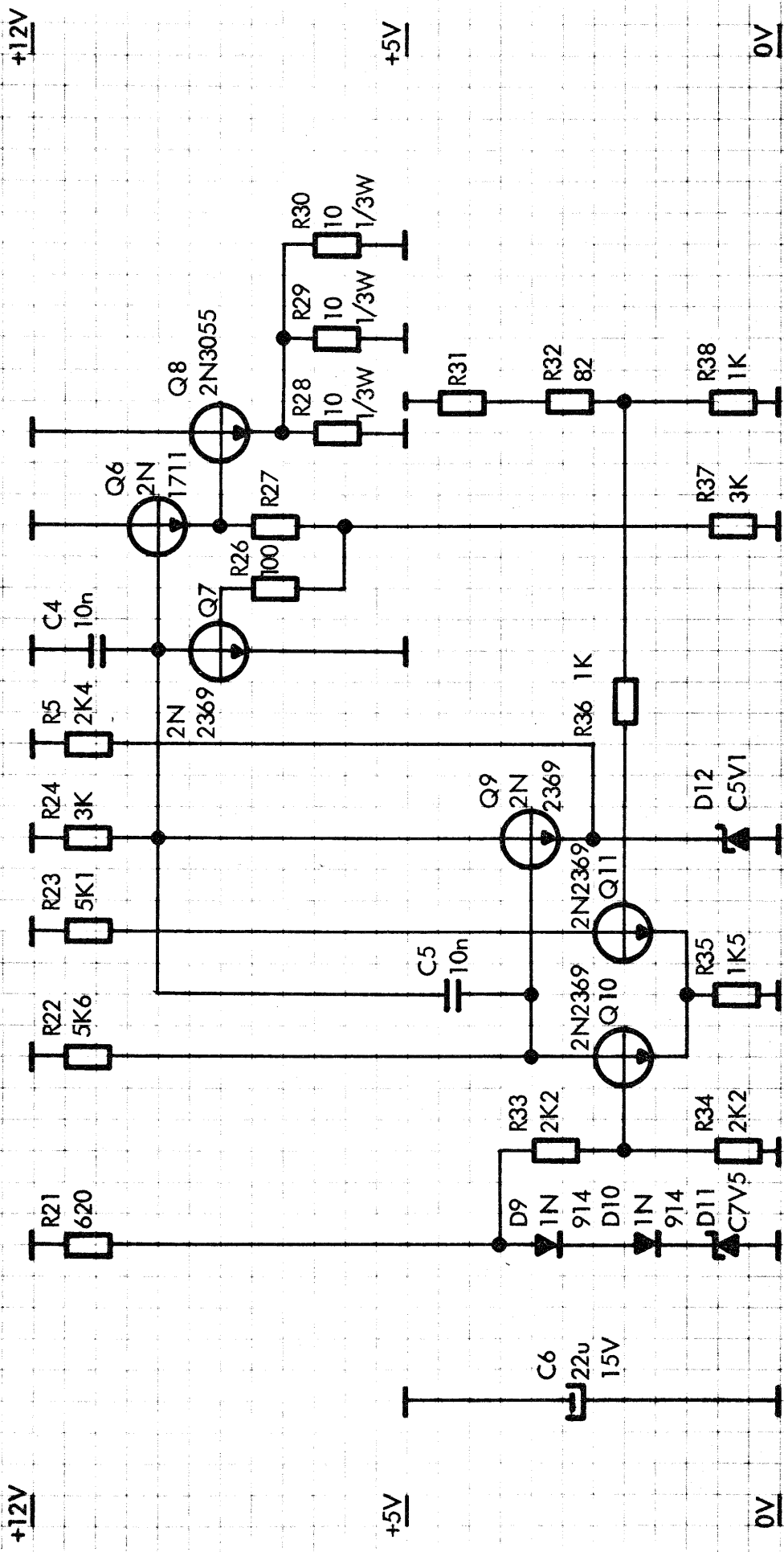

Unit
Dwg. No
V21043

+5V, +12V & -6V REG

PCBA Circuit Diagram

RC0908-1

p3 of 3p

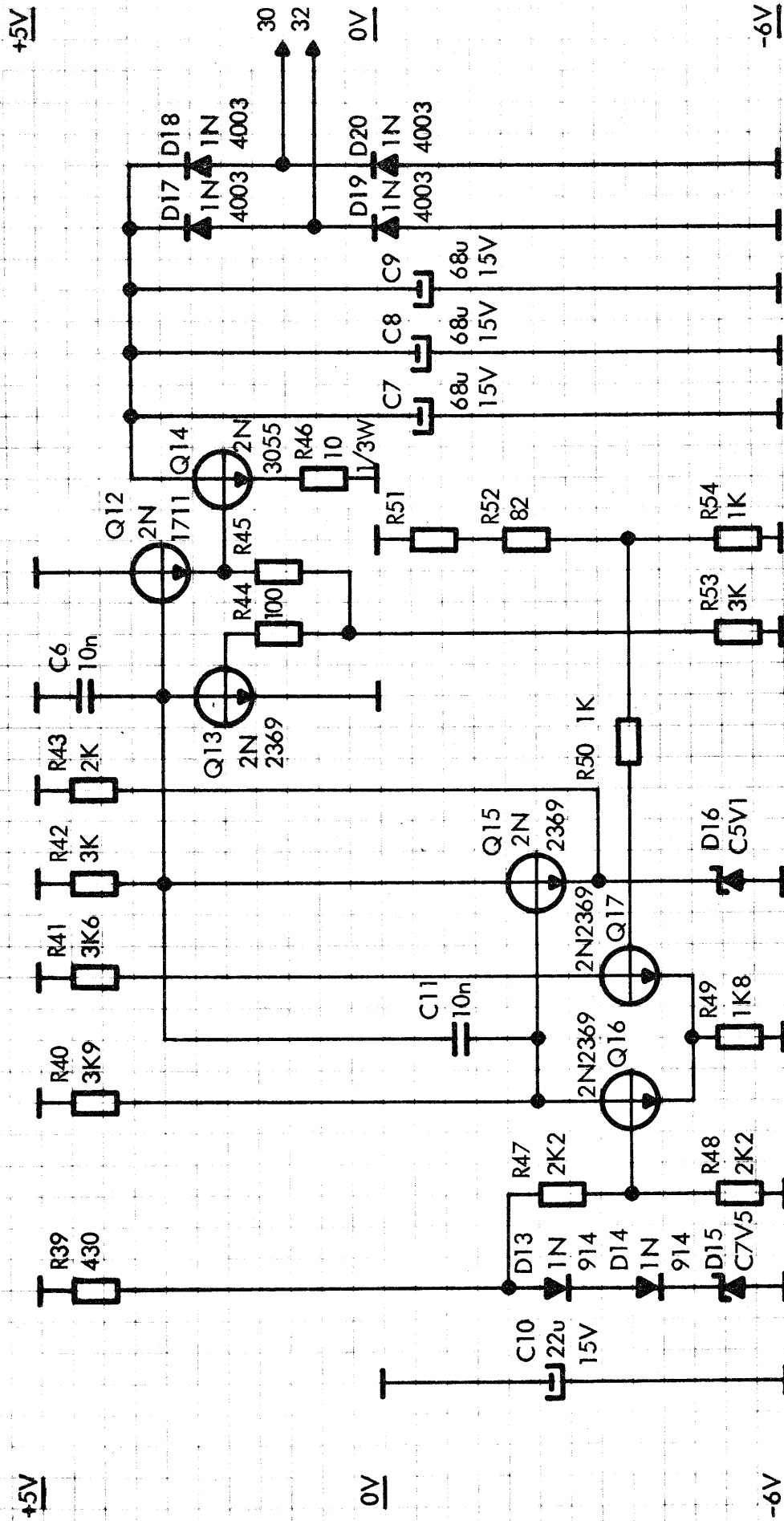

Zenerdiodes BZY88

+24V	PIN 3
+12V	PIN 1
+5V	PIN 22
0V	PIN 21
-6V	PIN 2

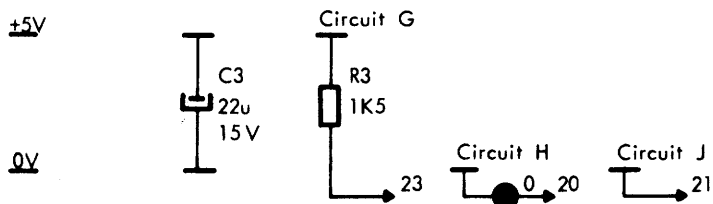
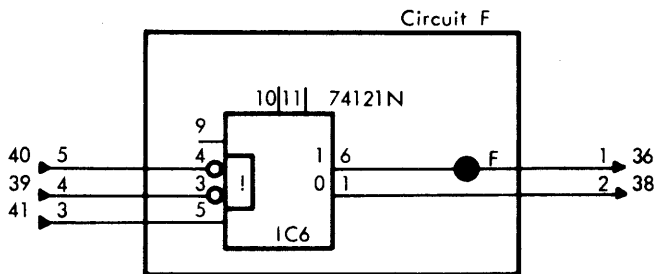
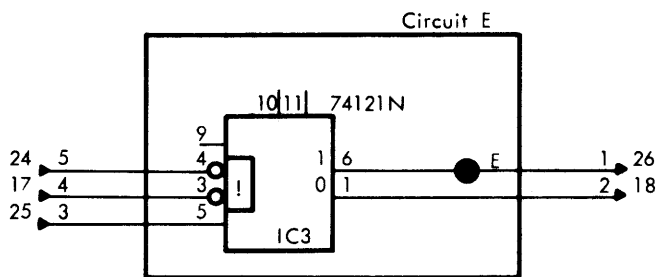
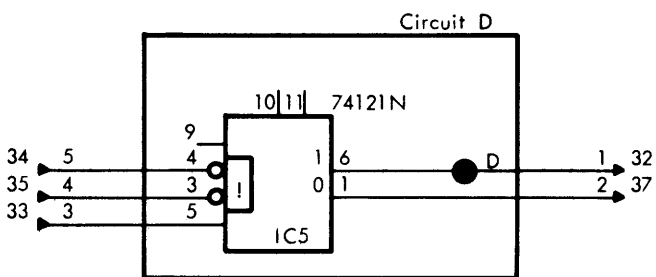
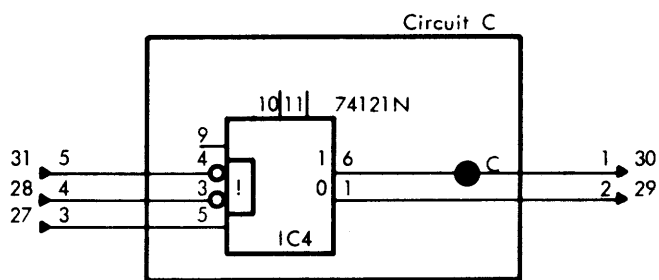
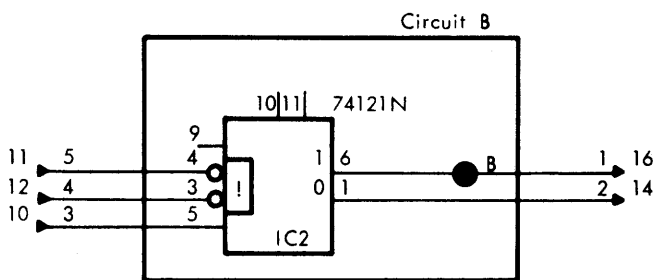
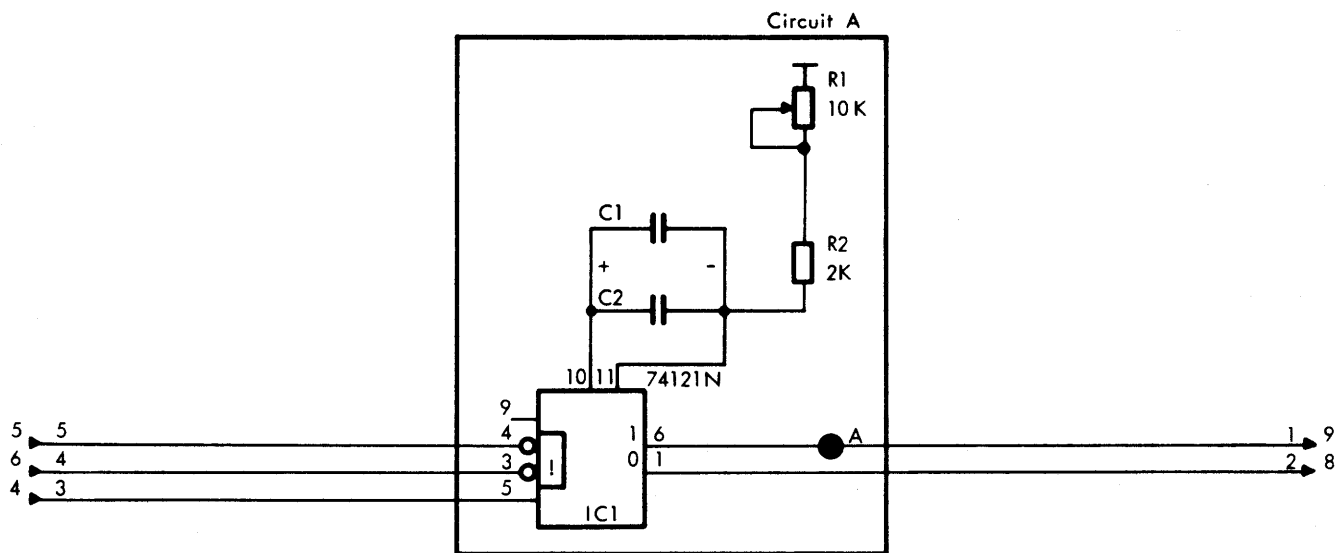

POWER REQUIREMENTS		
+5 V	PIN 22	152 mA
0 V	PIN 21	
POWER DISSIPATION 800 mW		

Circuit A

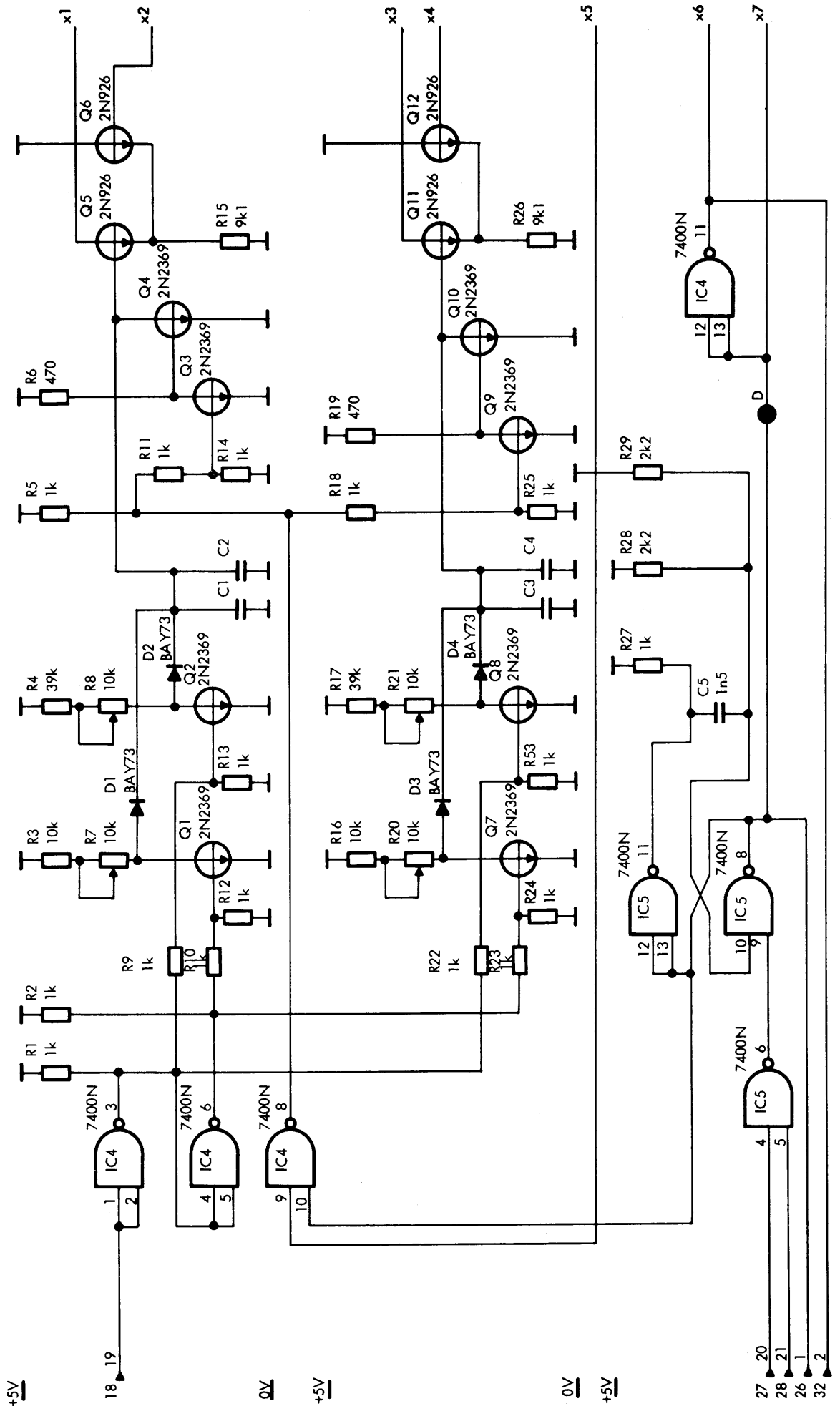

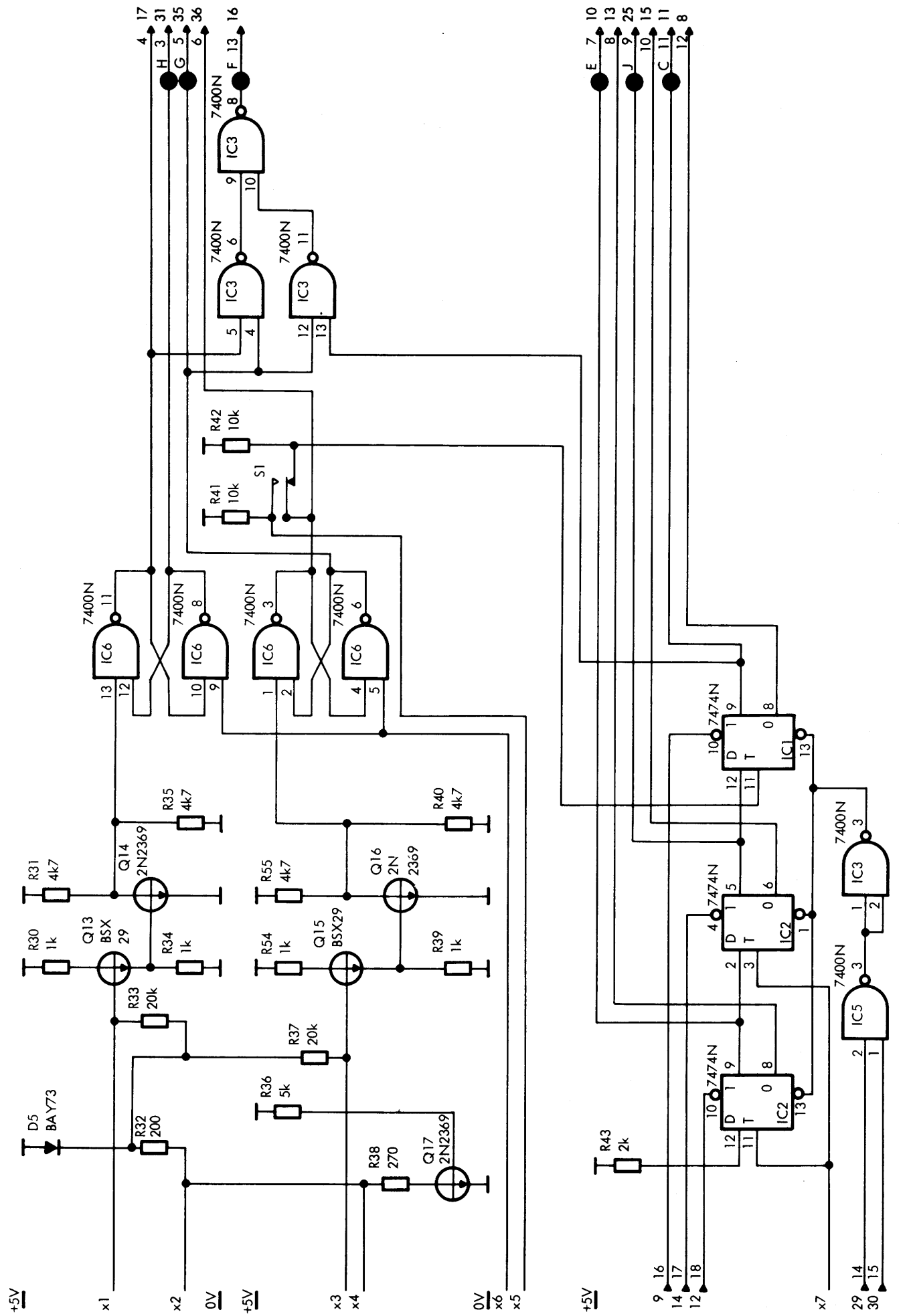

RCLM400

V11886

1SA402, 1CA403, 1BC401

PCBA Circuit Diagram

RC0911-1/

p2 of 3p

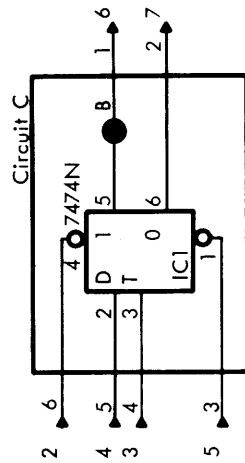
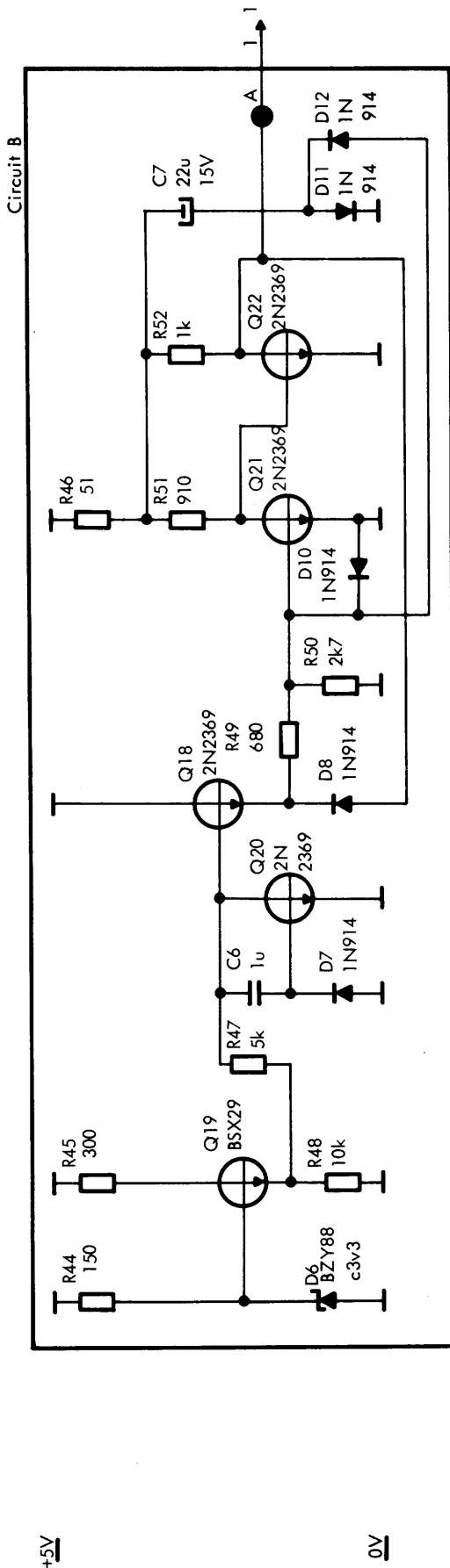

Circuit D

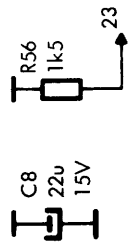

Circuit E



Circuit F



POWER REQUIREMENTS		
+5V	PIN 22	210mA
0V	PIN 21	
POWER DISSIPATION 1100mW		

+5V

0V

+50V
+5V

+50V
+5V

0V

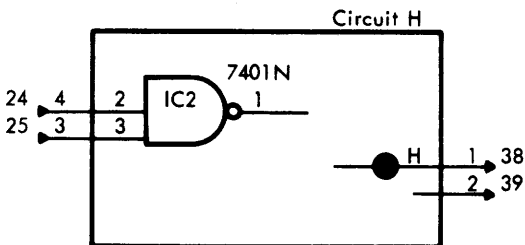
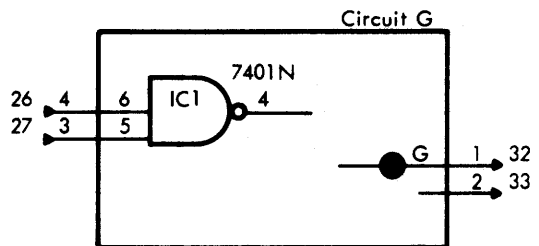
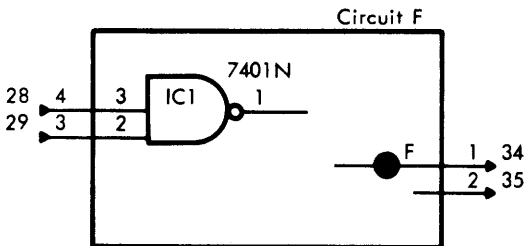
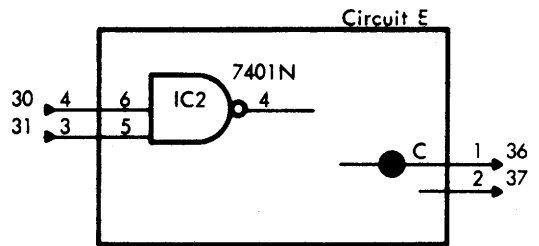
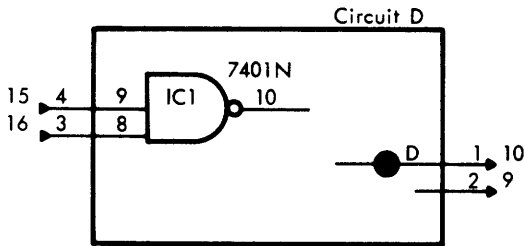
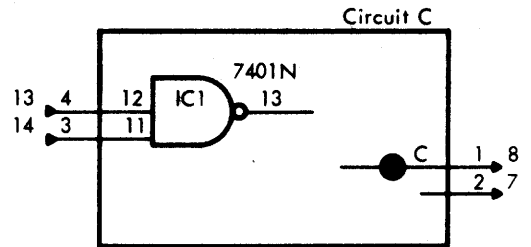
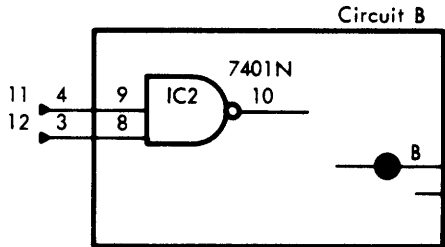
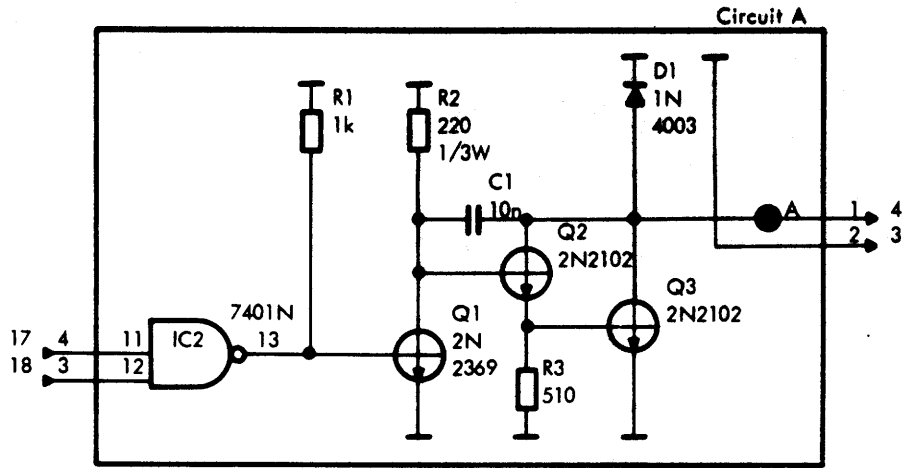

POWER REQUIREMENTS		
+50V	PIN 2	2600mA
+5V	PIN 22	145mA
0V	PIN 21	
POWER DISSIPATION 4.2W		

+50V
+5V

+50V
+5V

0V

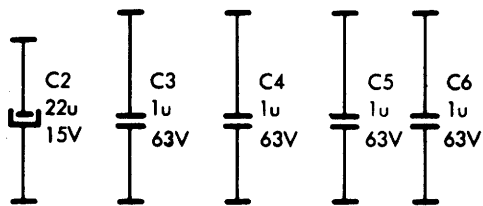

Circuit J

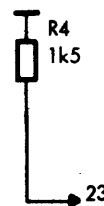

Circuit K



Circuit L

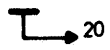

+5V

0V

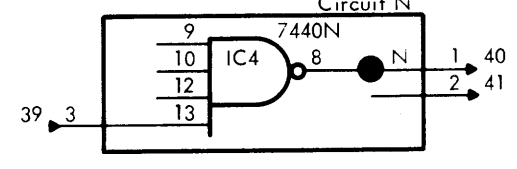
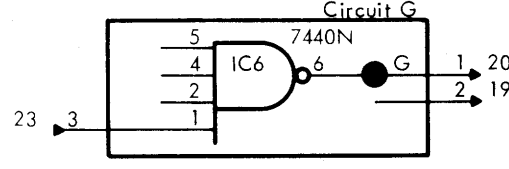
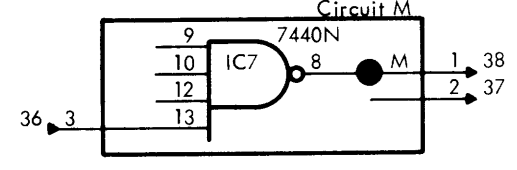
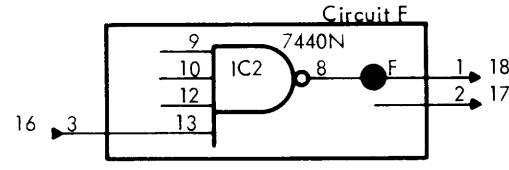
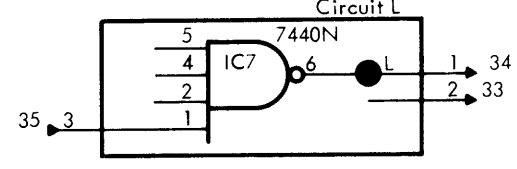
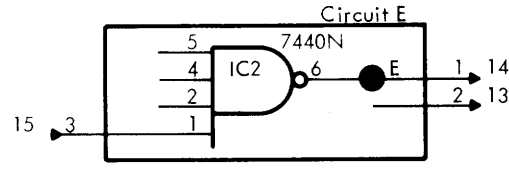
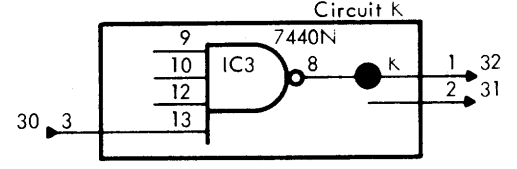
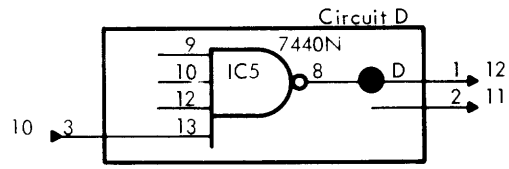
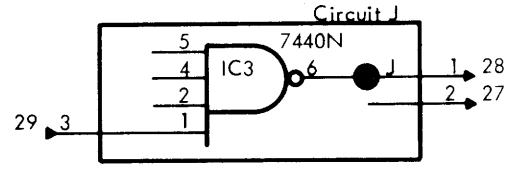
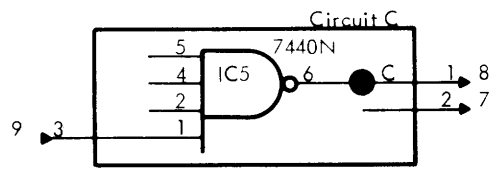
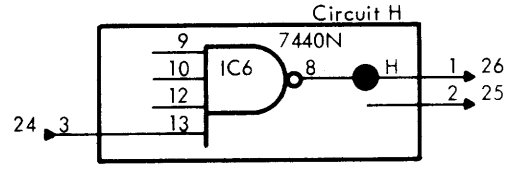
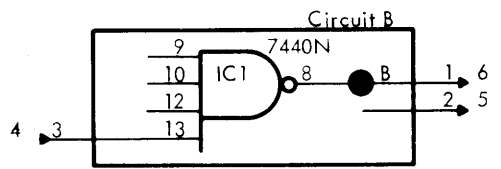
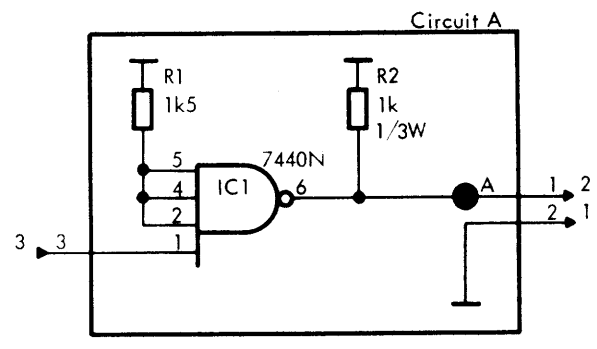

+5V

0V

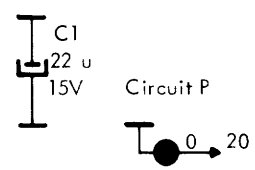

POWER REQUIREMENTS		
+5V	PIN 22	235mA
0V	PIN 21	
POWER DISSIPATION		

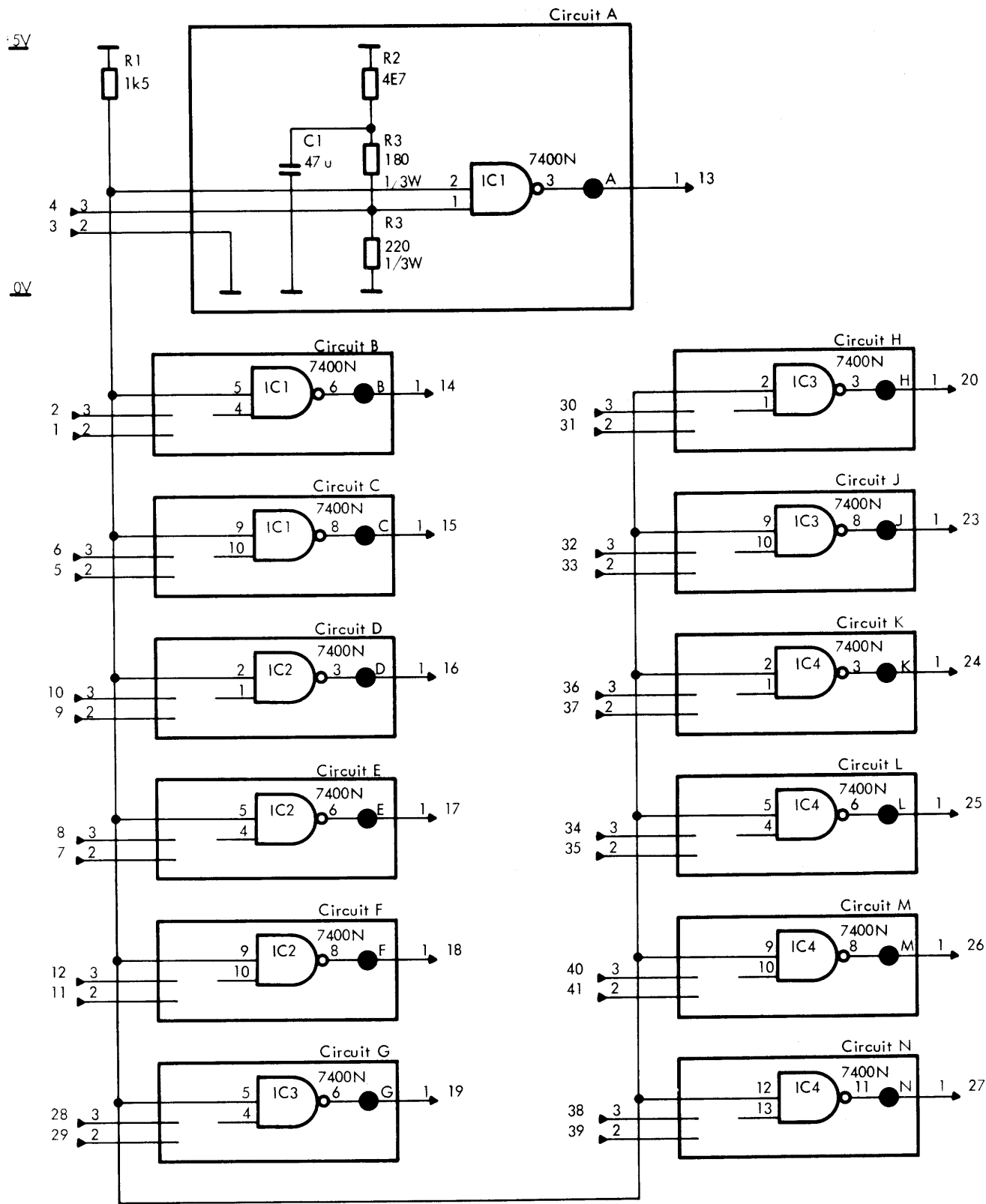

+5V
0V

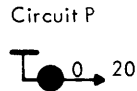
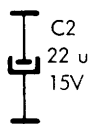

POWER REQUIREMENTS		
+5V	PIN 22	390mA
0V	PIN 21	
POWER DISSIPATION		

+12V
+5V

Circuit A

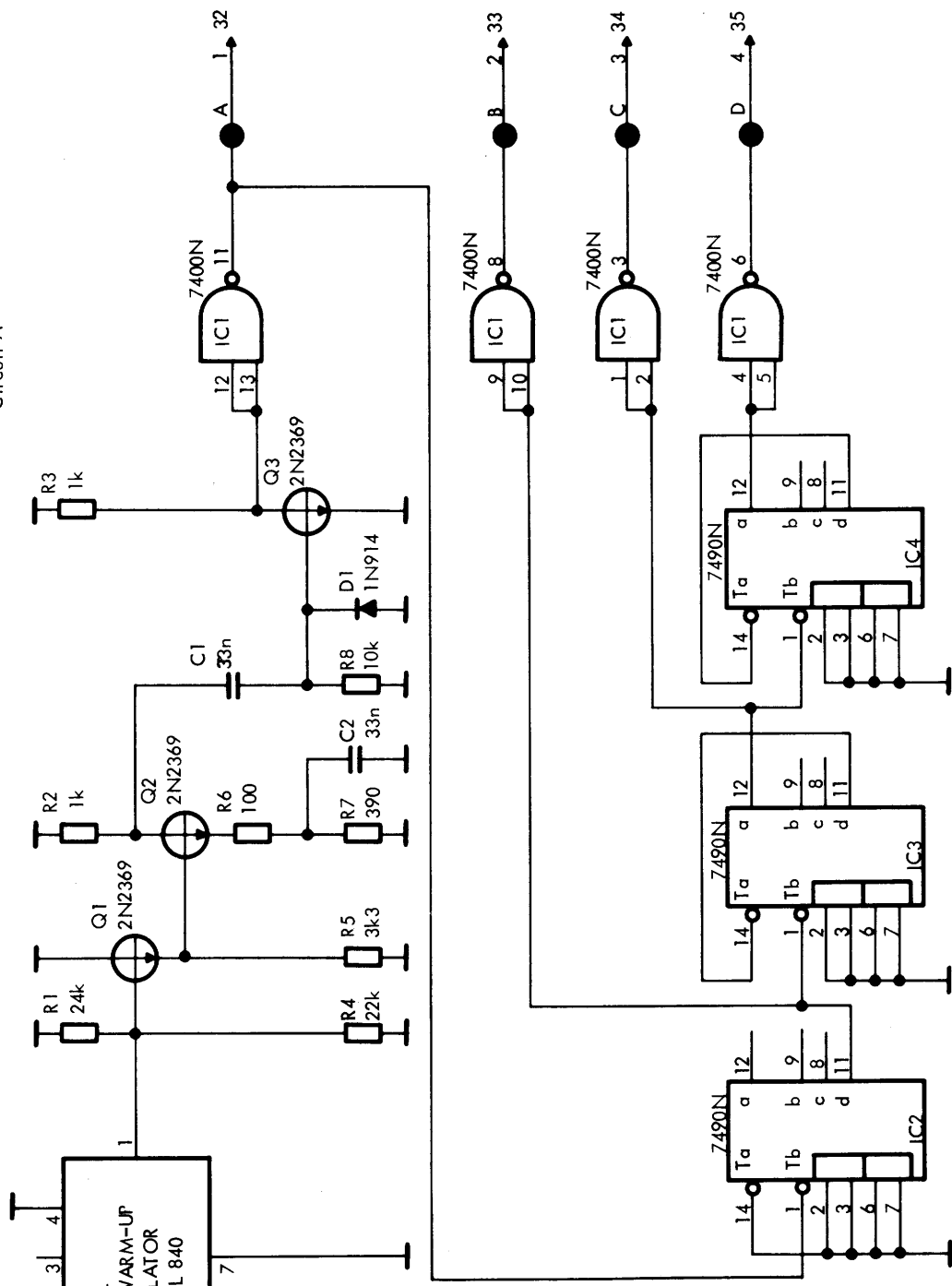

POWER REQUIREMENTS	
+12V	PIN 1 53 mA *
+5V	PIN 22 127 mA
0V	PIN 21
POWER DISSIPATION 1300 mW	

* Initial Surge : 500 mA for 40 sec.

+12V
+5V

RCLM 400
V11894

1CC407

PCBA Circuit Diagram

+12V
+5V

RC0928-1

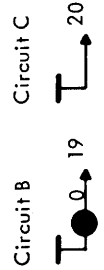
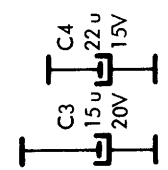

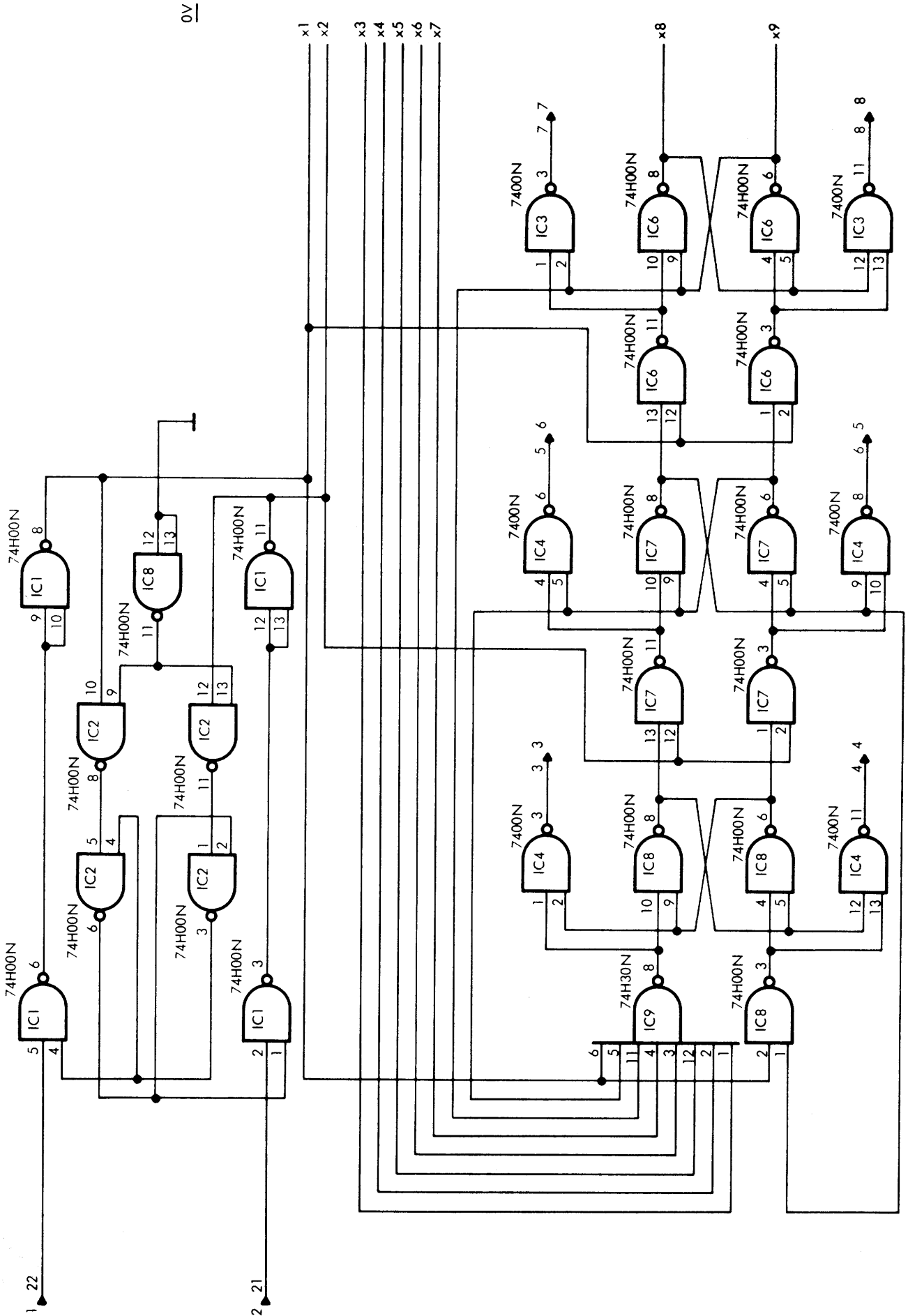

0V

0V

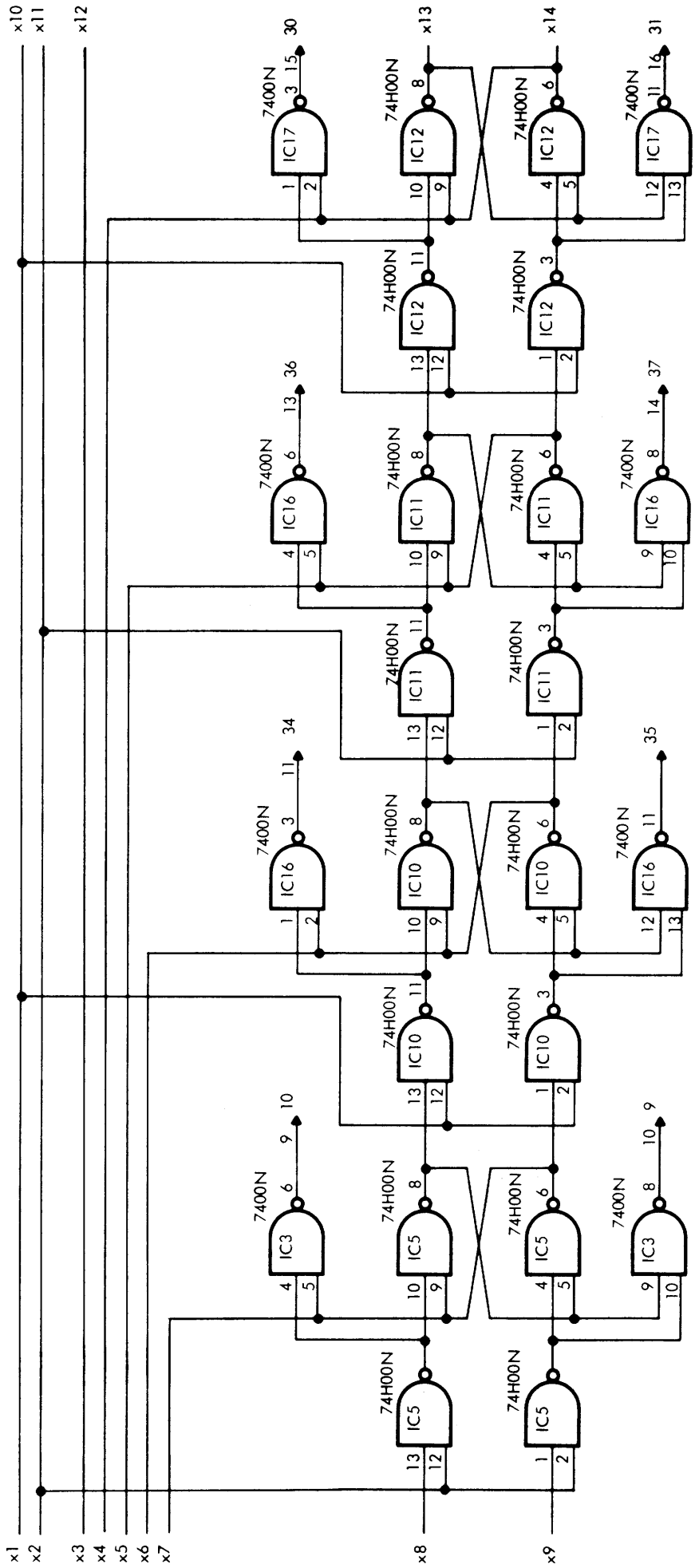

POWER REQUIREMENTS	
+5 V	PIN 22 160 mA
0 V	PIN 21
POWER DISSIPATION 850 mW	

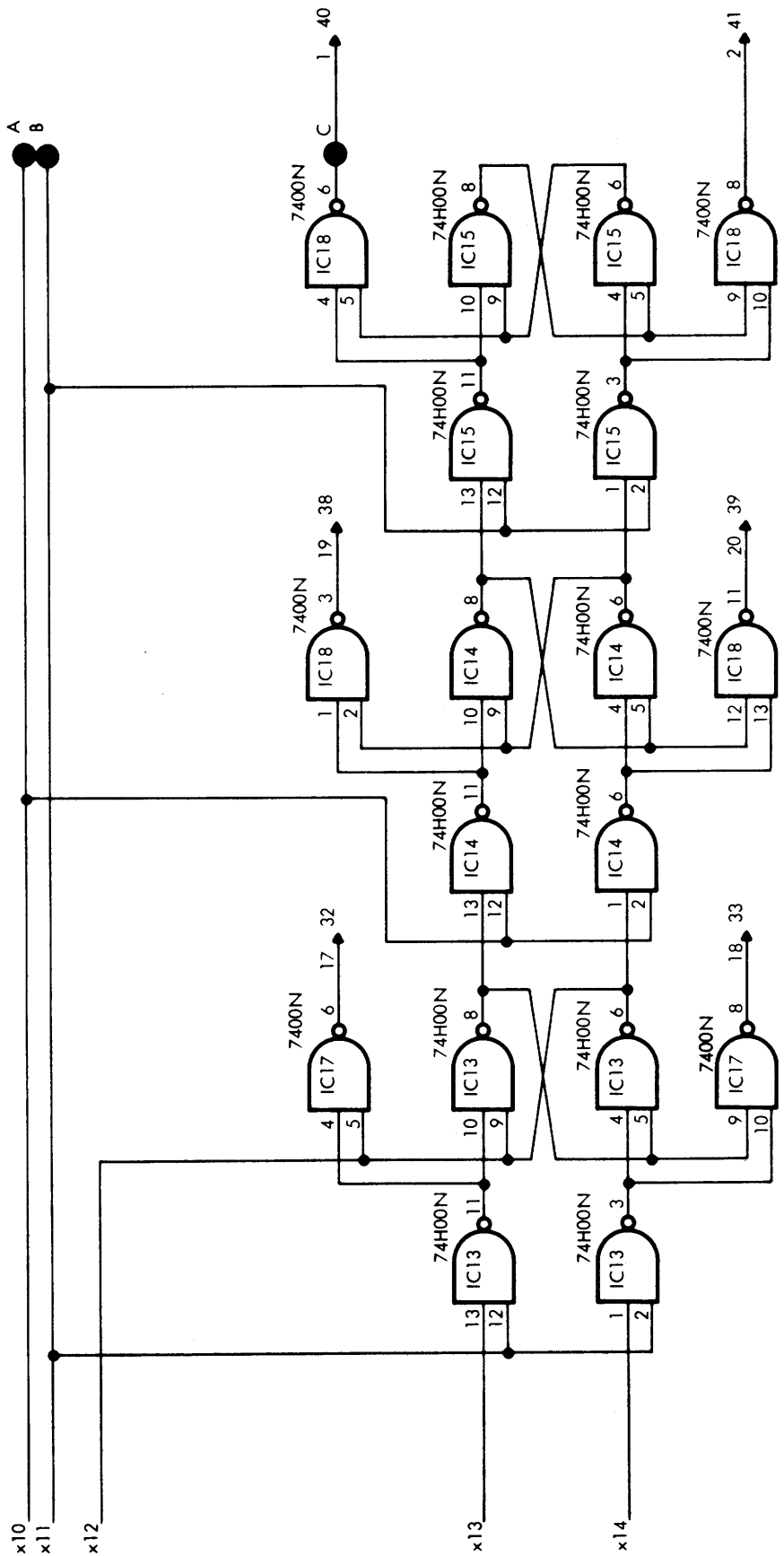
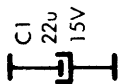

Circuit A

+7V
+5V

+7V
+5V

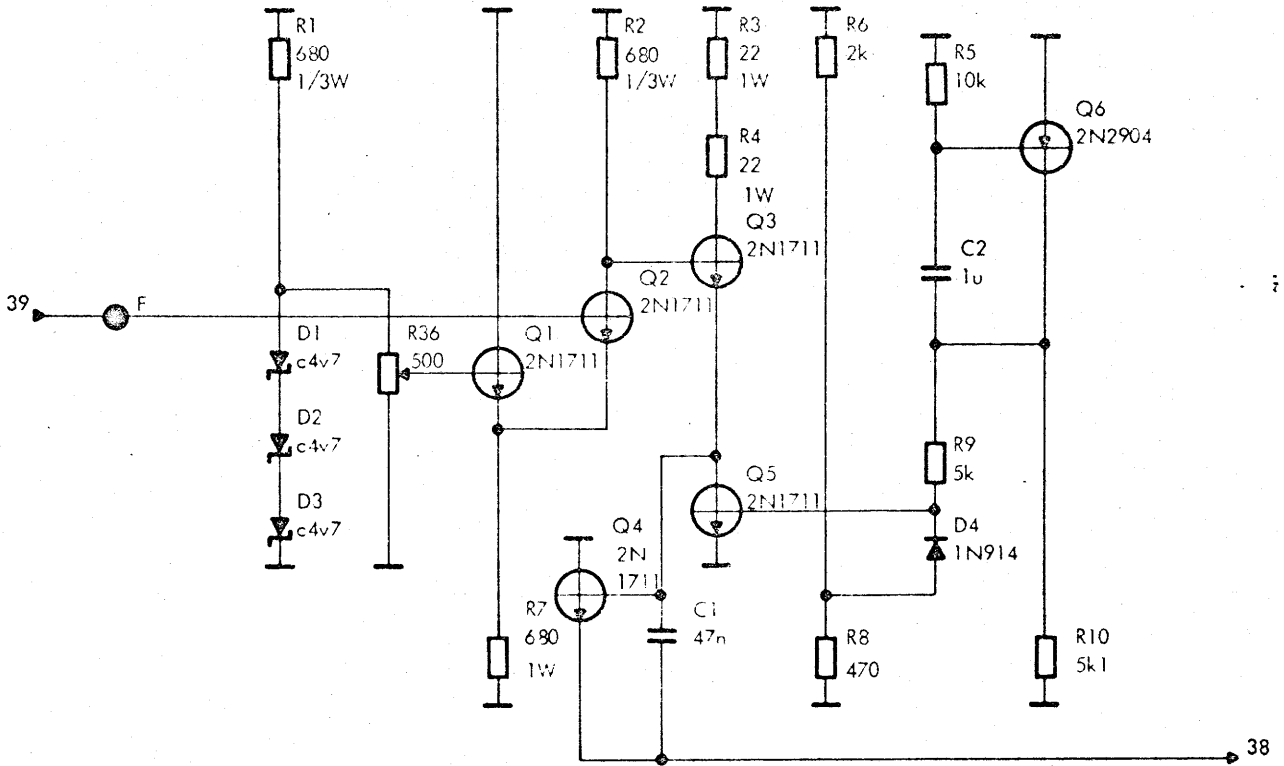

0V
-3V

0V
-3V

-16V

-16V

+7V
+5V

+7V
+5V

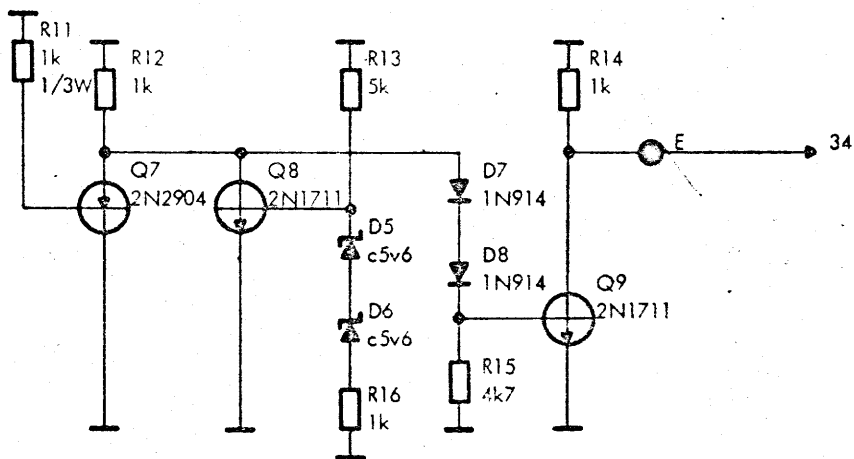

0V
-16V

0V
-16V

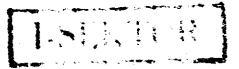

FACIT PUNCH PE 1500 - POWER SUPPLY UNIT, CURRENT SOURCE AMPLIFIER, POWER SUPERVISION, SCR - BOOSTER, AND GATE - CURRENT - AMPLIFIERS.

RC4000

RC0931 - 2

V12482

PCBA Circuit Diagram

pl of 2p

0705810G 140470HA 300970 328

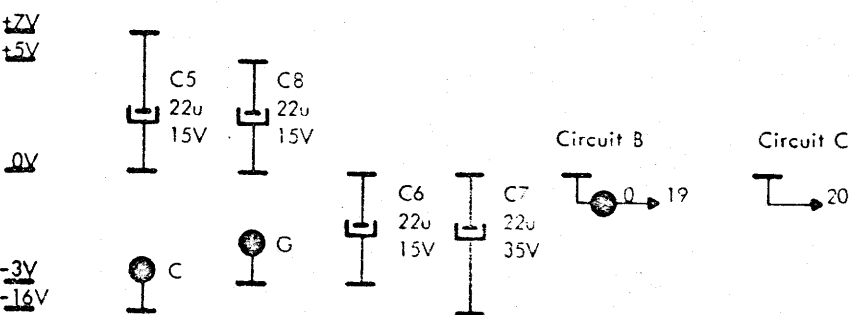
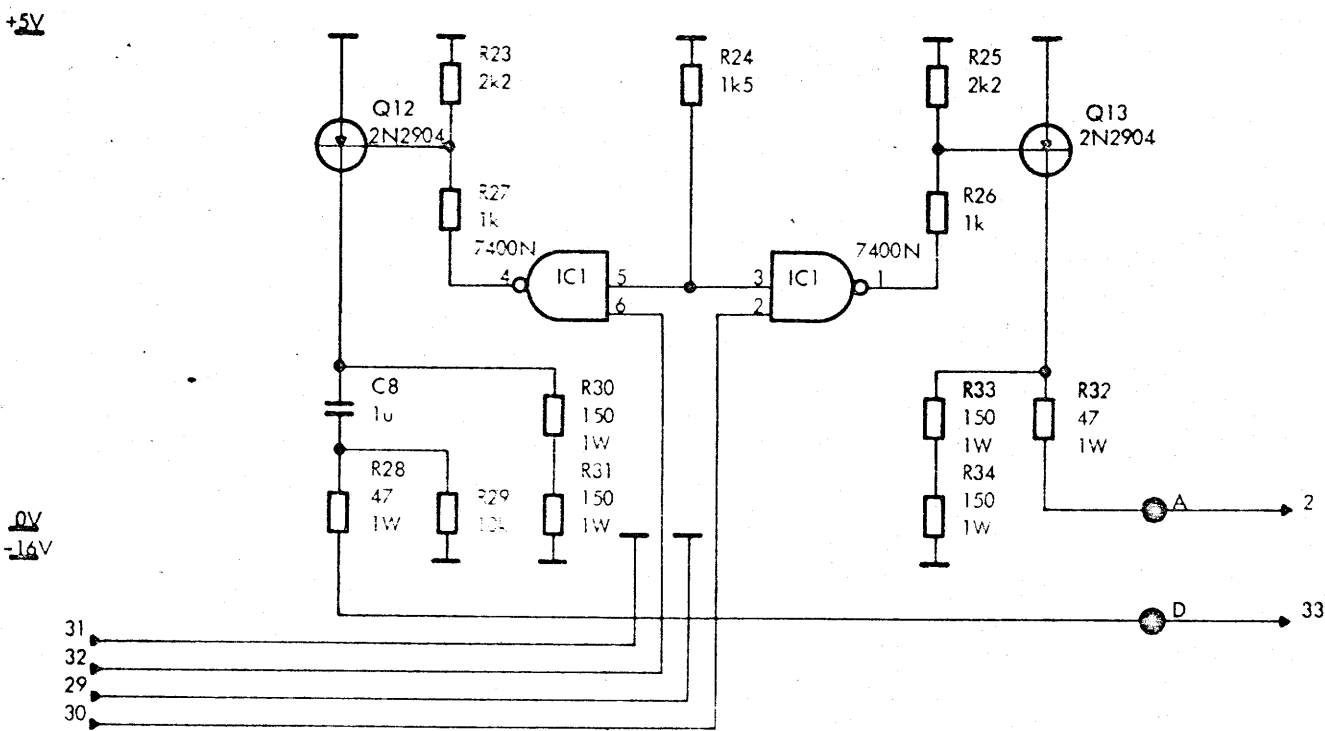
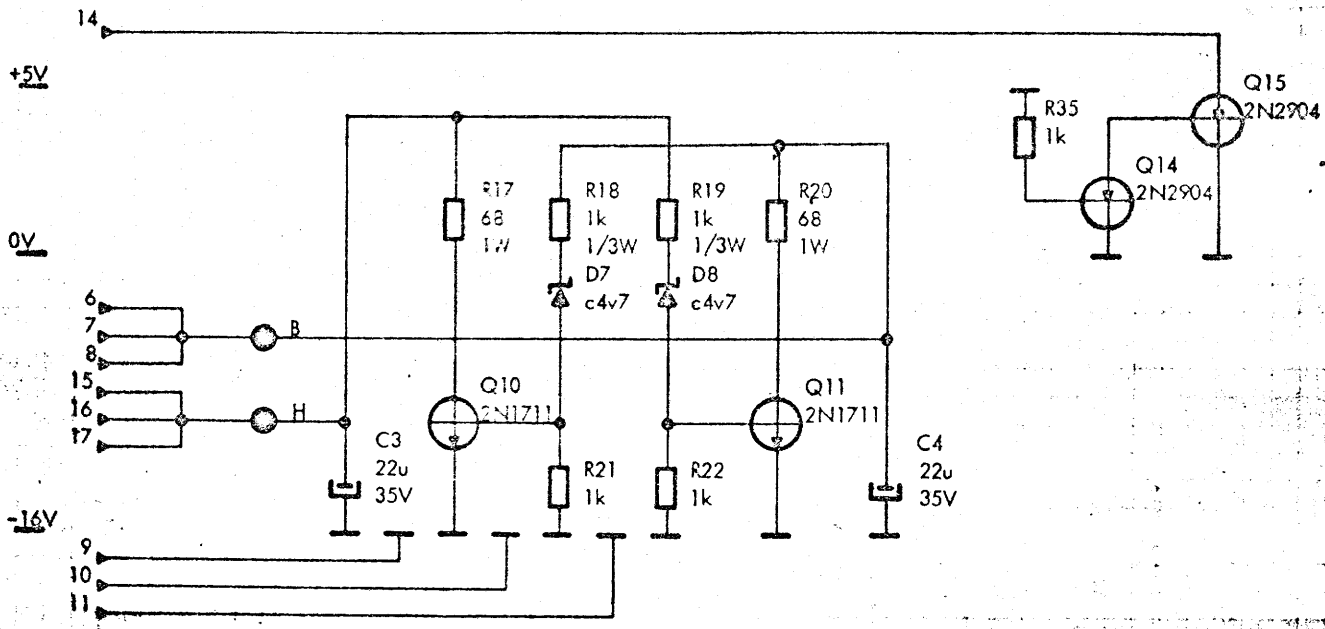

POWER REQUIREMENTS		
+7V	PIN 3	
+5V	PIN 22	50 mA
0V	PIN 21	
-3V	PIN 5	
-16V	PIN 4	3 A peak
POWER DISSIPATION 5W		

Zenerdiodes are BZY88



FACIT PUNCH PE1500 - POWER SUPPLY UNIT, CURRENT SOURCE AMPLIFIER, POWER SUPERVISION, SCR - BOOSTER, AND GATE - CURRENT - AMPLIFIERS.

07056810G 140470HA 310170AL 3009 70 306G

RC4000

VI2483

PCBA Circuit Diagram

RC0931 - 2

p2 of 2p

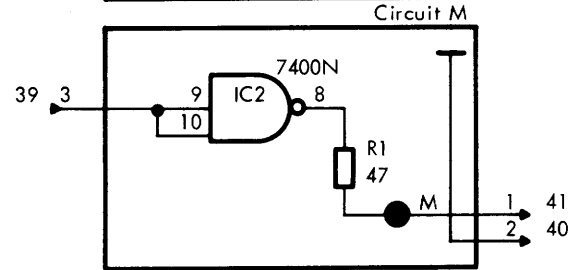
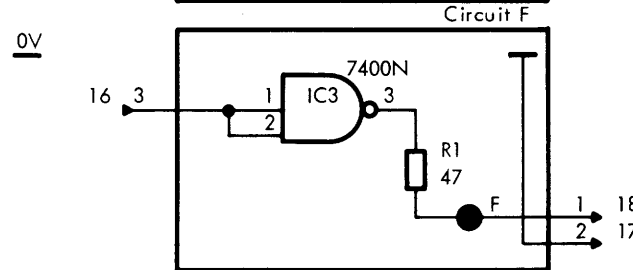
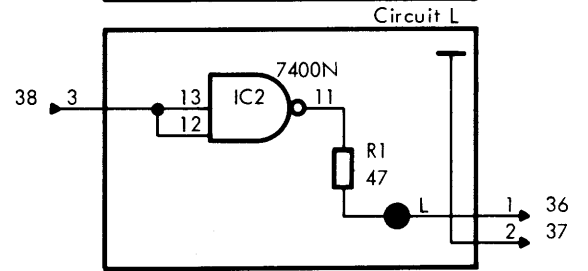
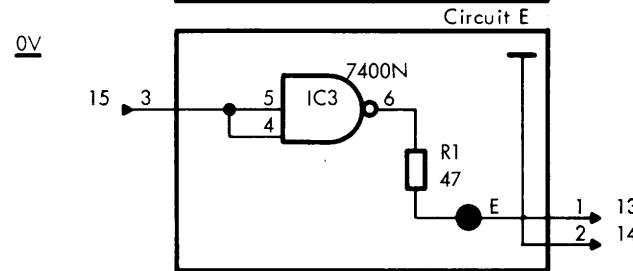
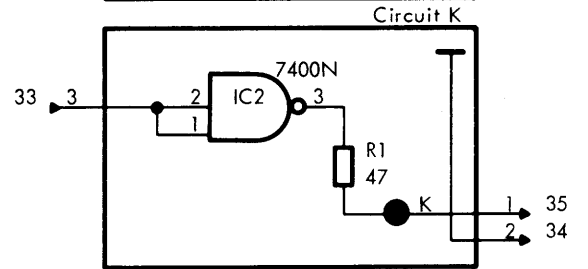
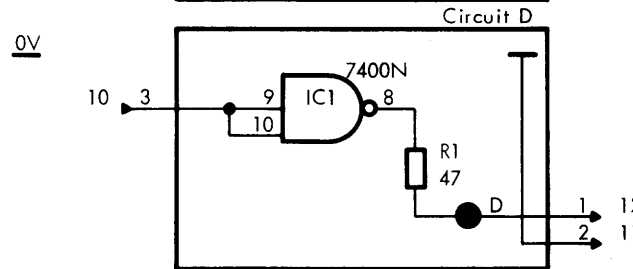
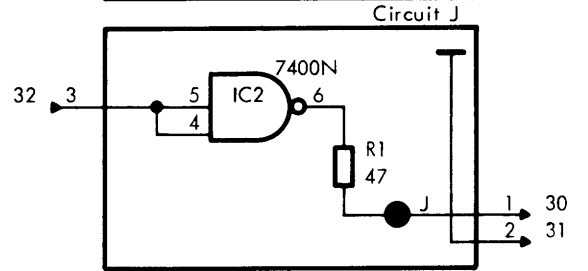
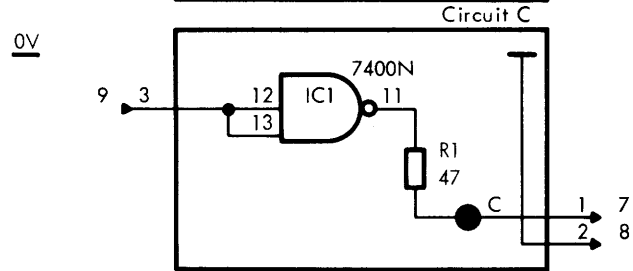
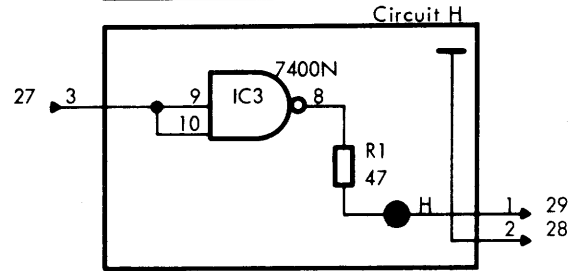
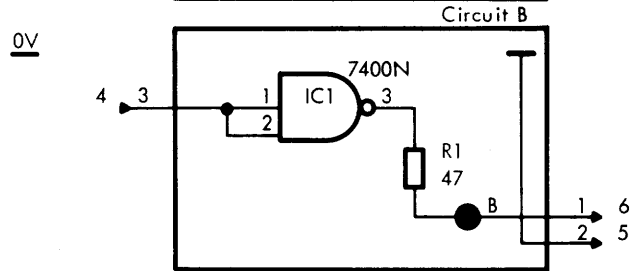
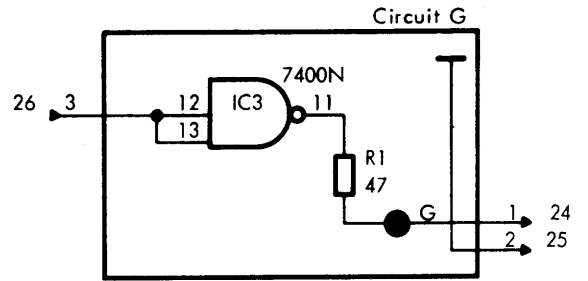
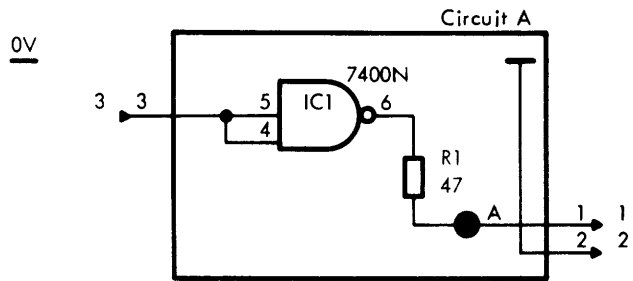

+5V
0V

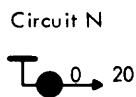
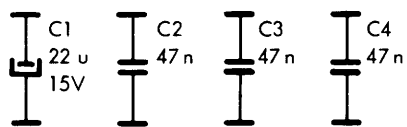

POWER REQUIREMENTS		
+5V	PIN 22	40 mA
0V	PIN 21	
POWER DISSIPATION 210 mW		

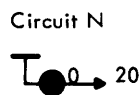
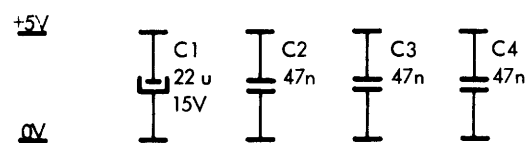
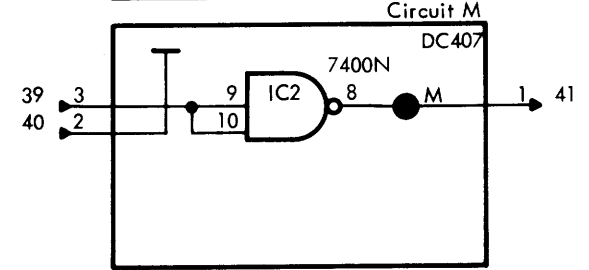
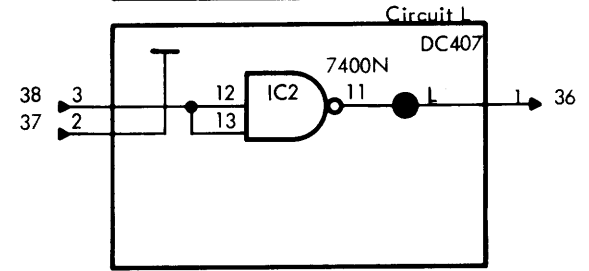
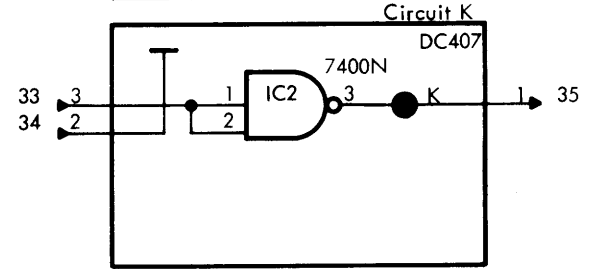
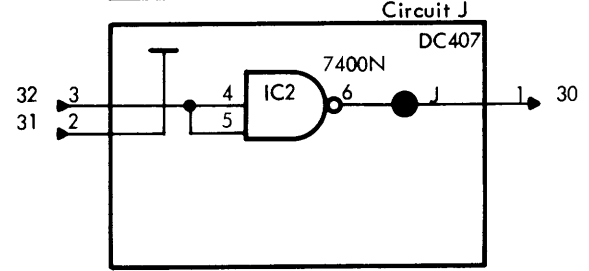
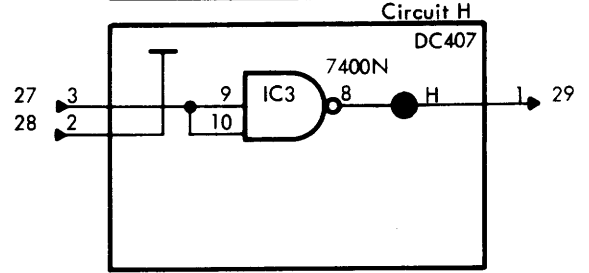
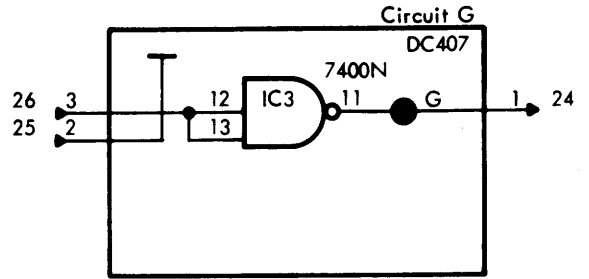
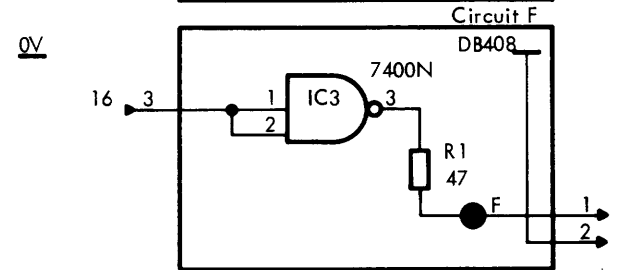
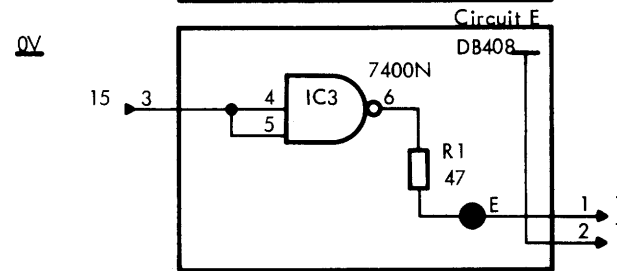
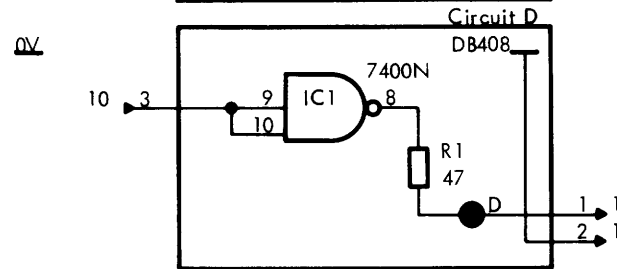
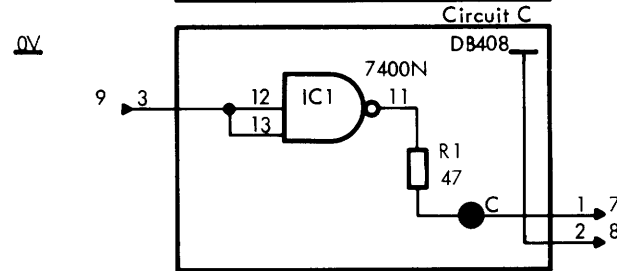
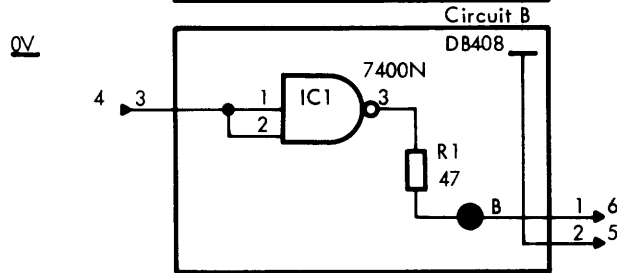
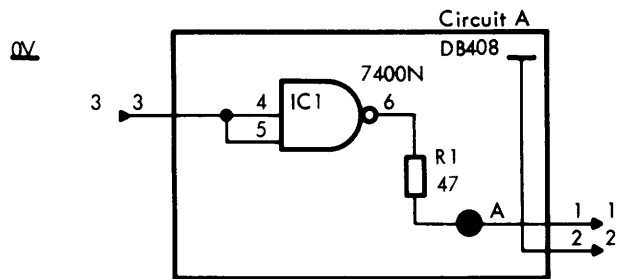

POWER REQUIREMENTS		
+5V	PIN 22	40 mA
0V	PIN 21	
POWER DISSIPATION 210 mW		

+12V

+5V

-12V

POWER REQUIREMENTS	
+12V	PIN 1 260 mA
+5V	PIN 22 130 mA
0V	PIN 21
-12V	PIN 4 280 mA
POWER DISSIPATION 7200 mW	

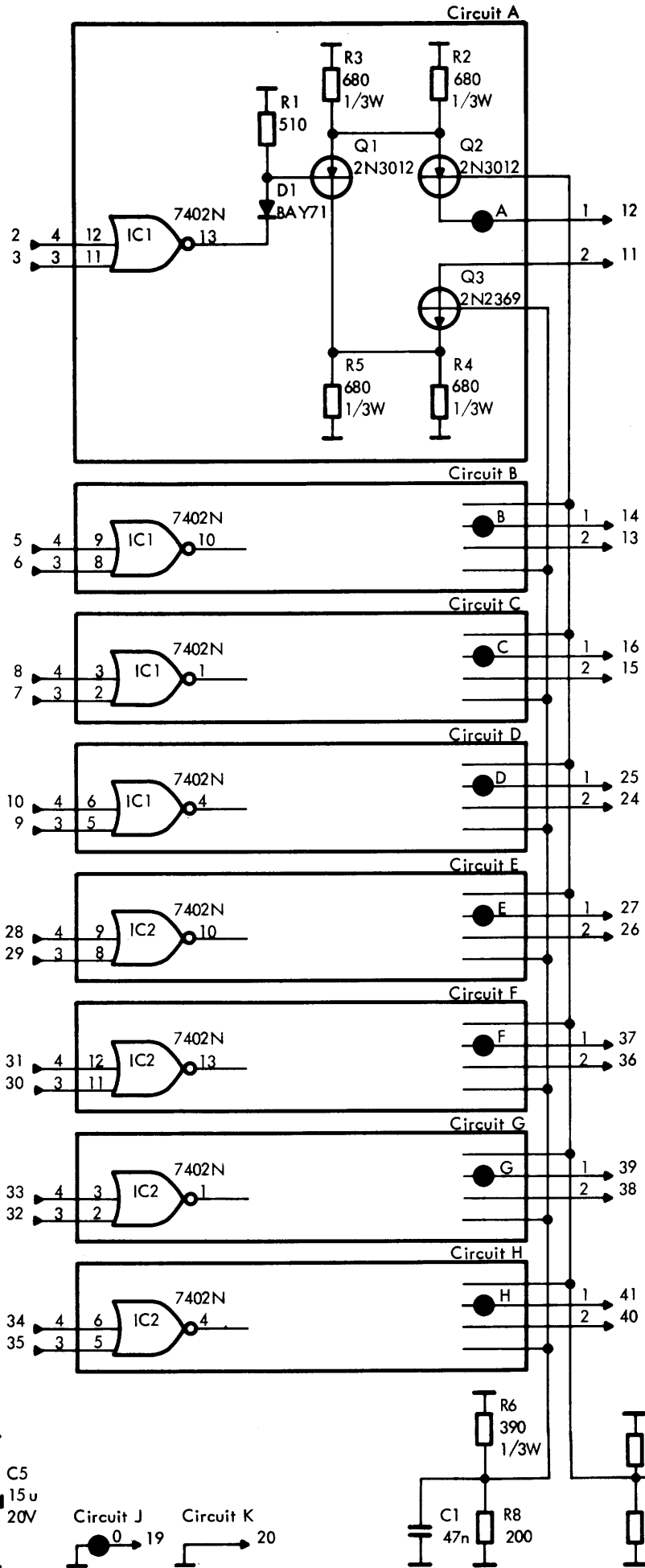

-12V

+5V

+12V

0V

-12V

+5V

+12V

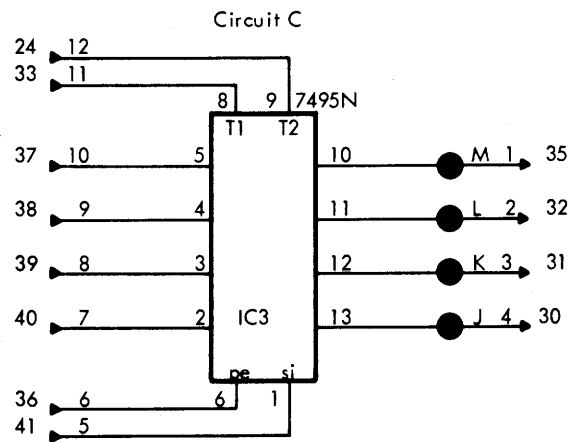
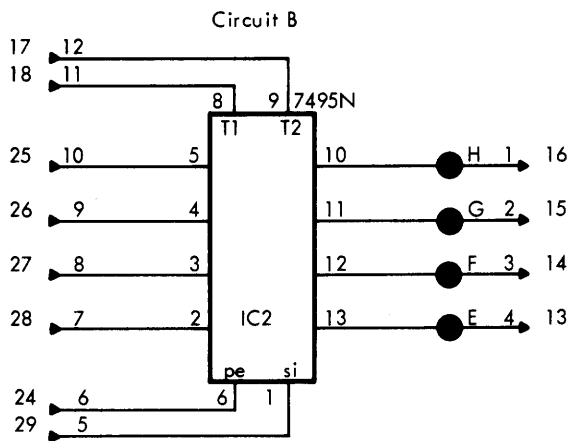
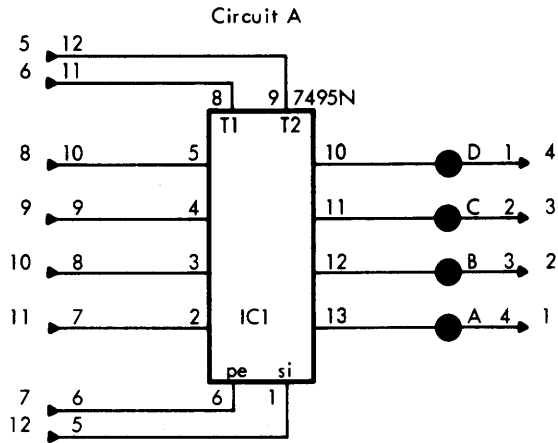

+5V

0V

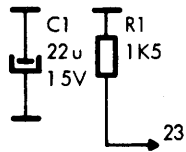

Circuit D Circuit E

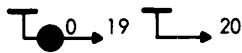

POWER REQUIREMENTS		
+5V	PIN 22	265 mA
0V	PIN 21	
POWER DISSIPATION 1400 mW		

+5V

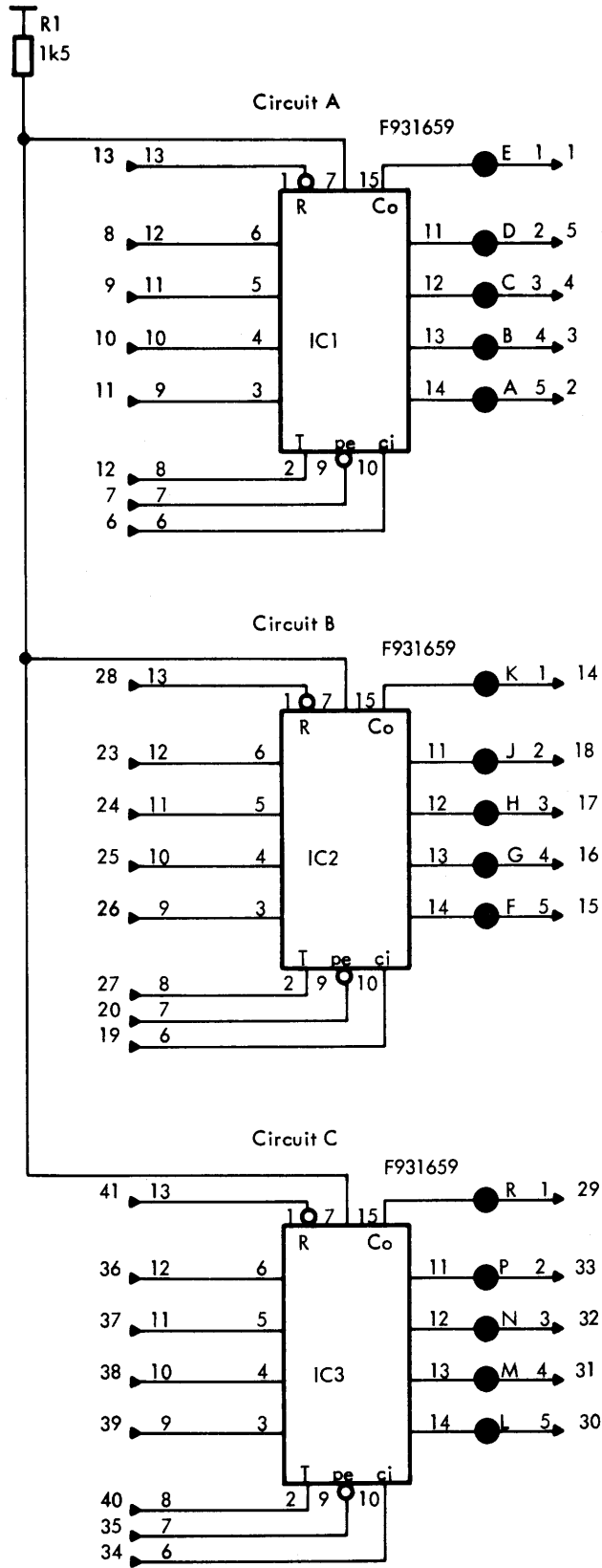

+5V

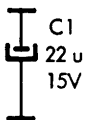

0V



POWER REQUIREMENTS		
+5V	PIN 22	250mA
0V	PIN 21	
POWER DISSIPATION		1320mW

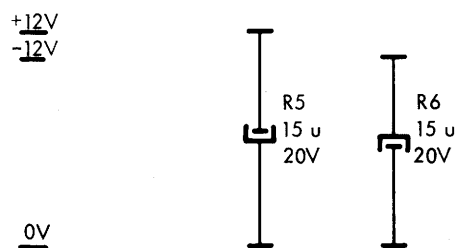
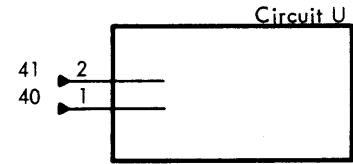
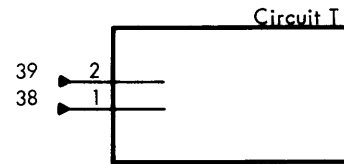
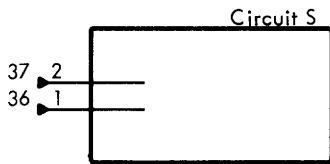
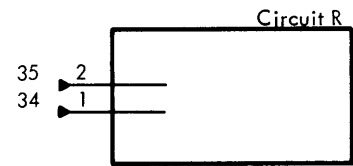
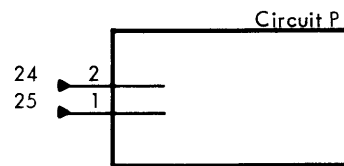
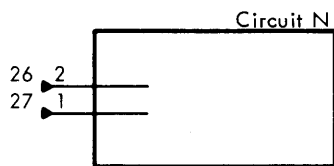
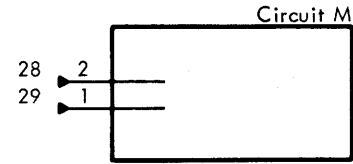
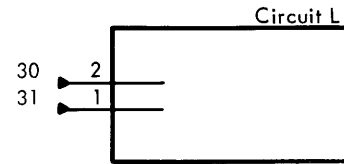
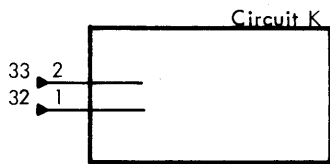
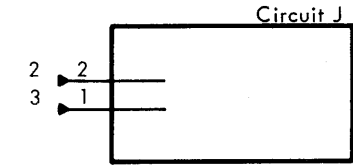
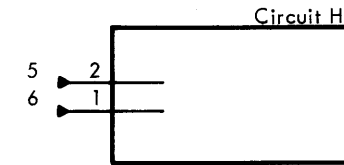
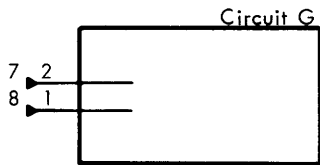
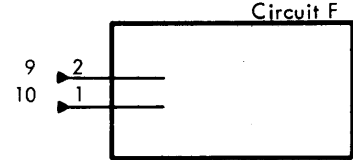
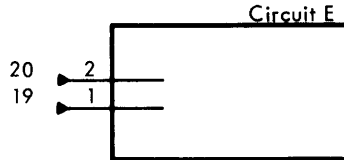
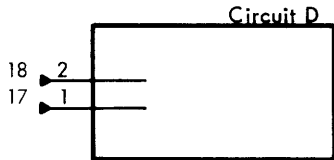
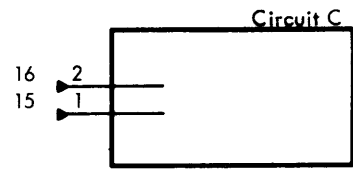
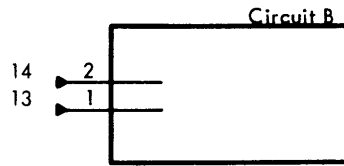
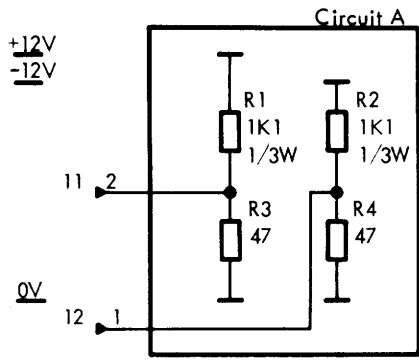

POWER REQUIREMENTS		
+12V	PIN 1	180 mA
0V	PIN 21	
-12V	PIN 4	180 mA
POWER DISSIPATION 5300 W		

150972AL 150972BA 150972KS
 K373 KS K373 KS

Circuit A

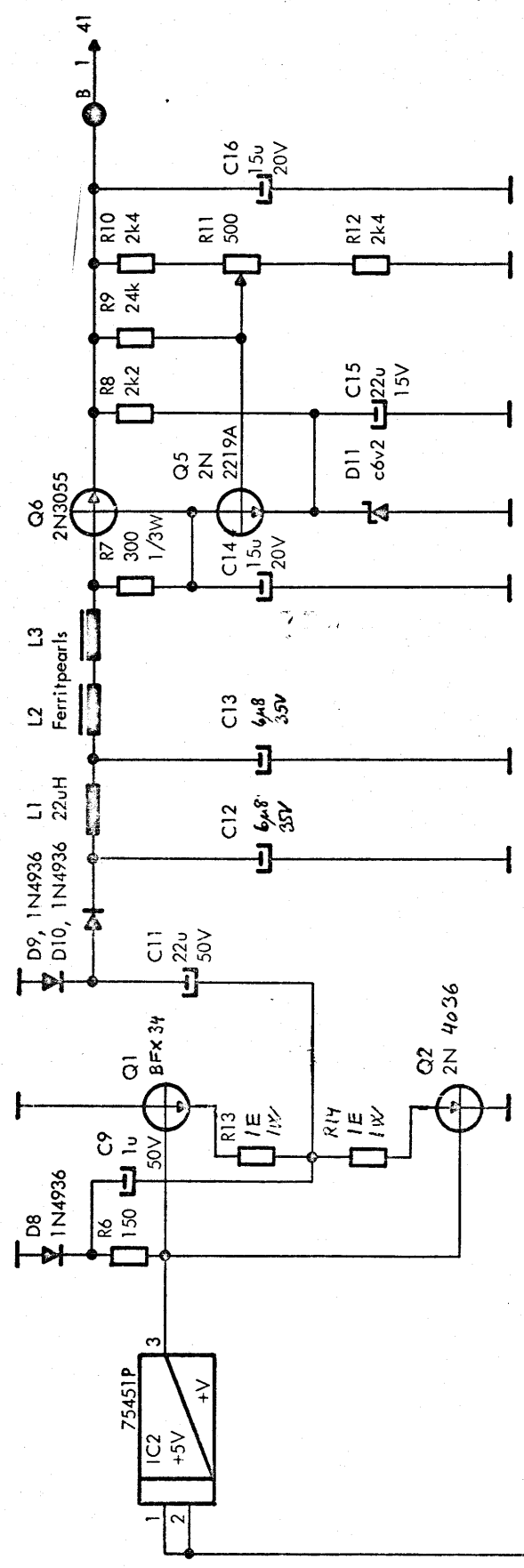

POWER REQUIREMENTS	
+12V	PIN 1 1A
+5V	PIN 22 40mA
0V	PIN 21 5mA
-6V	PIN 2 5mA
POWER DISSIPATION 12.84W	

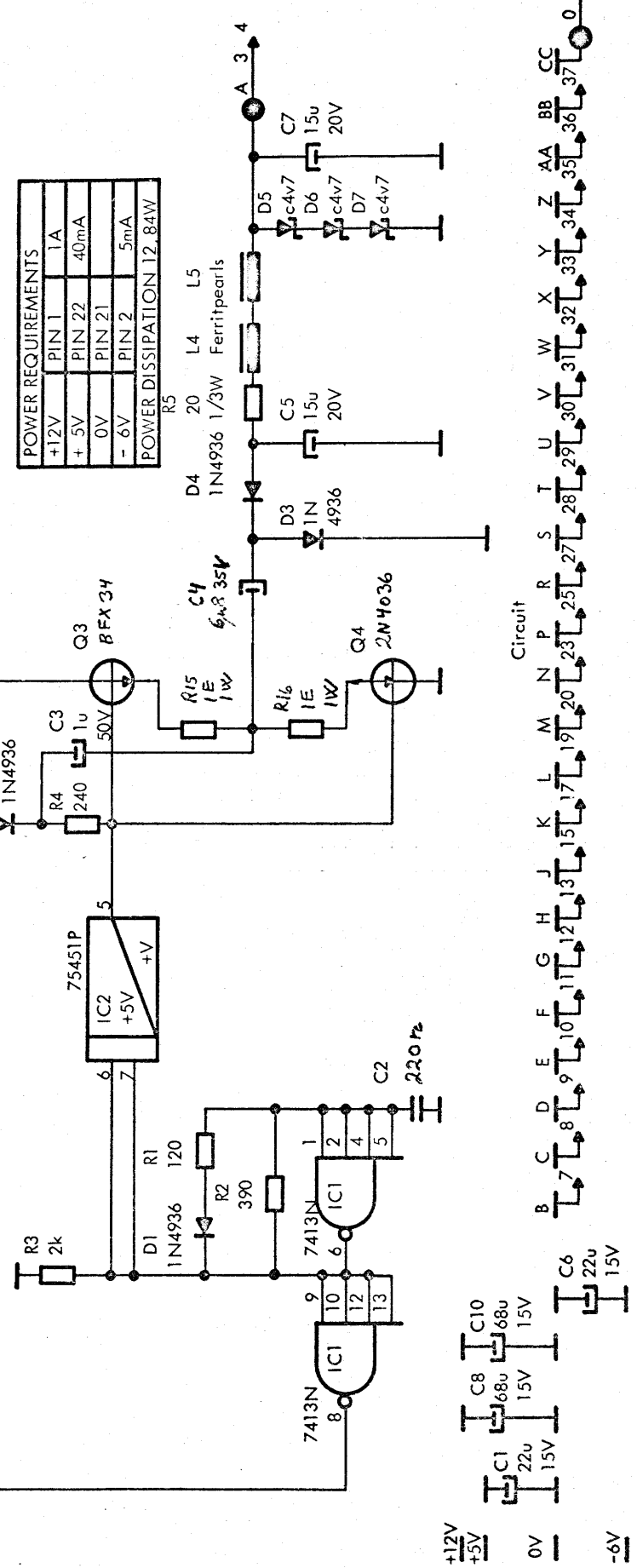

Circuit

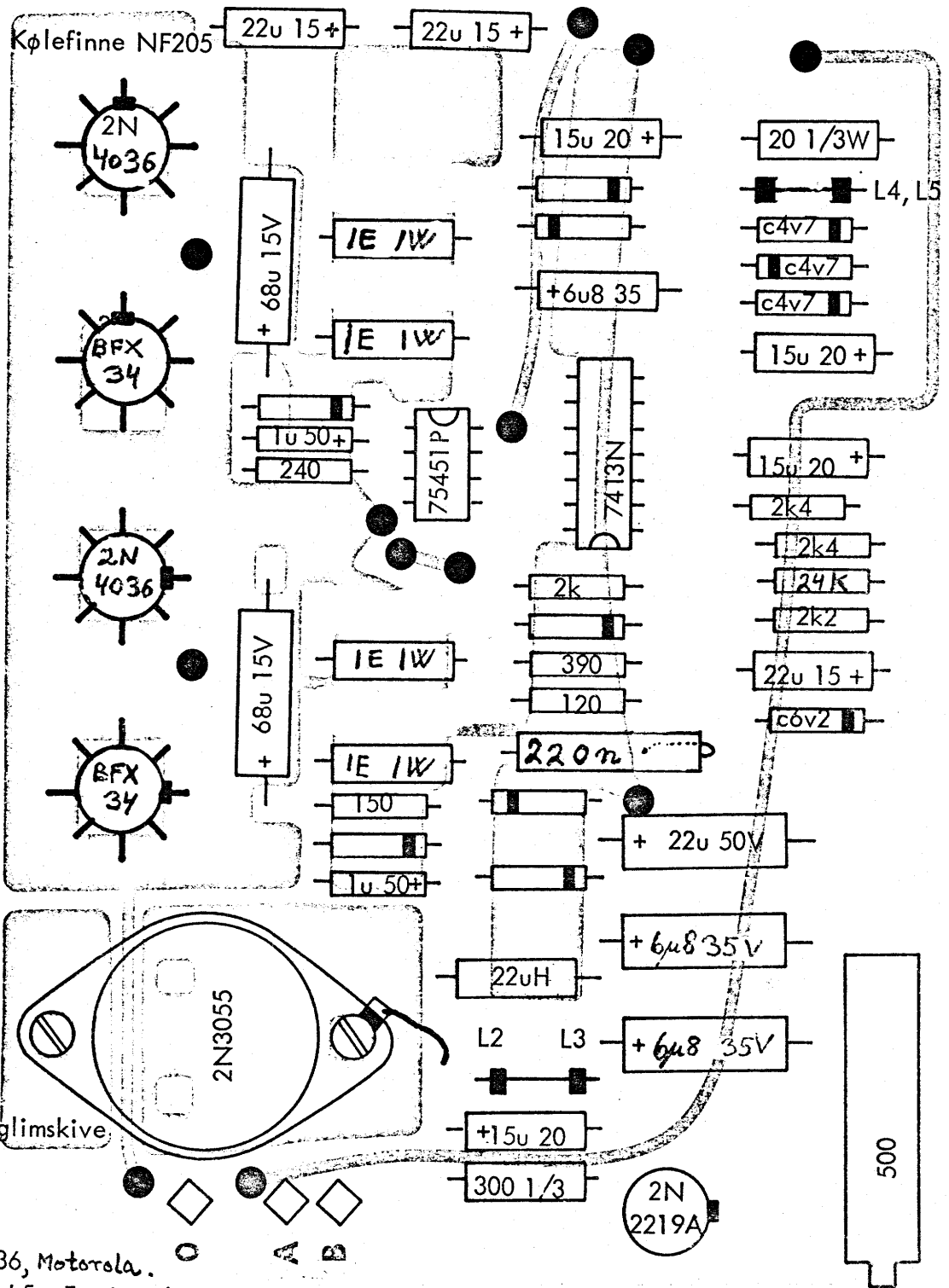

Monteres med glimskive

Dioder: 1N4936, Motorola.
L2, L3, L4 og L5 : Ferritperler

Unit: RCLM400	Designed 15.3.73	MONTERINGSTEGNING RC2069 - 1	Drawing No V23312	
A/S REGNE CENTRALEN	Approved		Drawn by	
	Checked		Checked	
	Last Revision		Sheets	Sheet

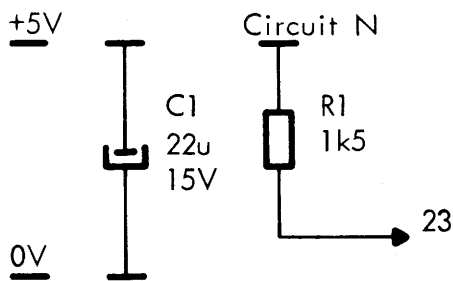
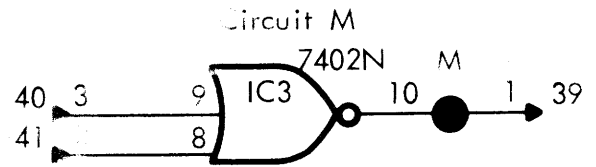
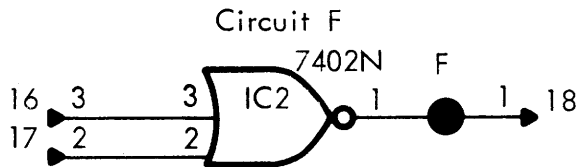
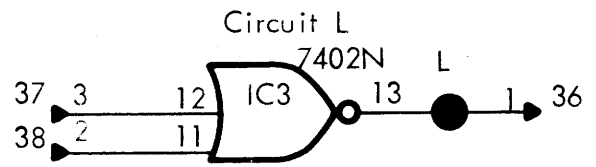
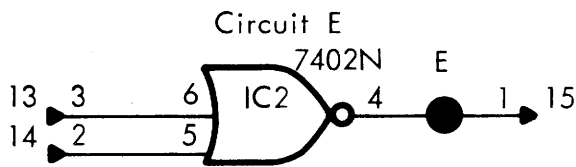
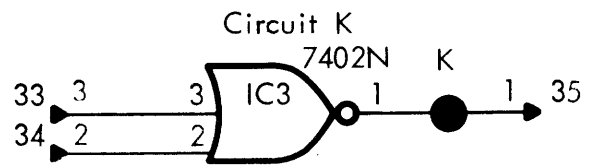
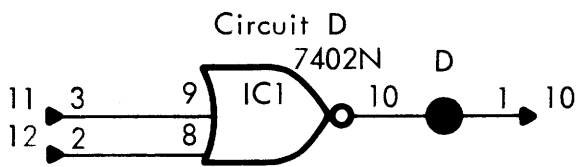
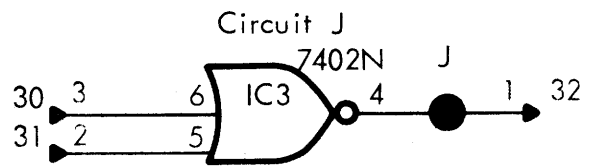
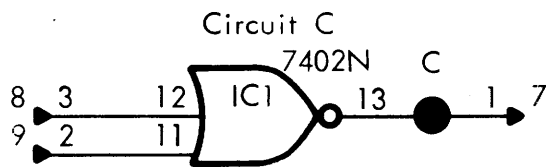
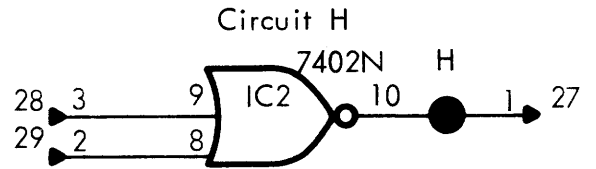
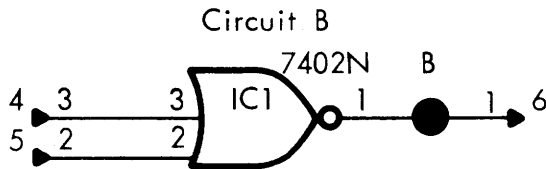
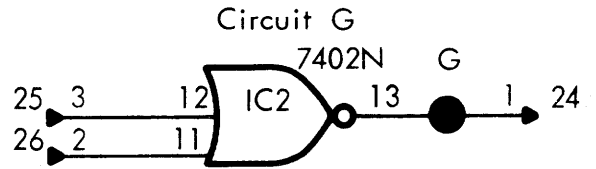
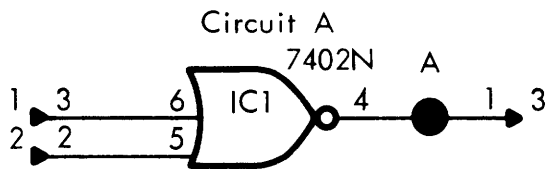

POWER REQUIREMENTS		
+5V	pin 22	49mA
0V	pin 21	
POWER DISSIPATION: 270mW		

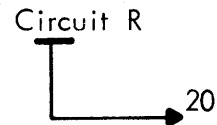
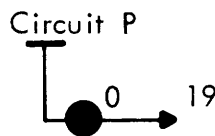

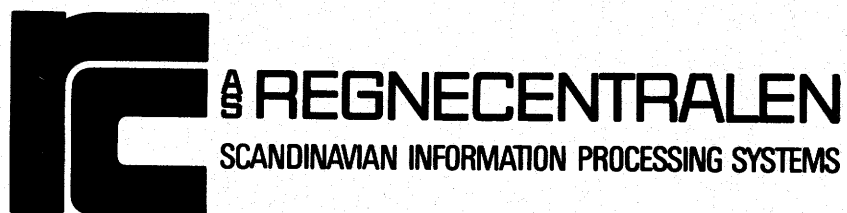

REGNECENTRALEN

SCANDINAVIAN INFORMATION PROCESSING SYSTEMS

FALKONERALLE 1 · DK 2000 COPENHAGEN F
DENMARK — TELEPHONE: (01) 10 53 66
CABLES: REGNECENTRALEN · TELEX: 6282 RC HQ DK