

# RC LOG LIST

UNIT 7M 949 F. 809 MODEL ..... NO .....

This LOG LIST contains information on modifications of the basic unit, due to Options, Engineering Change Notes, and Field Change Orders.

Do not forget to list all future modifications on this page.

OPTION ECN or FCO No.	DATE of Installation	SIGN	SHORT DESCRIPTION
FCO 541	10/31/72	SP	CNC - 0. 10/11
FCO 4023	15.11.72	SP	
FCO 553	17.12.72	SP	REPAIR WORK, TIME 30



# **hardware manual**

---

TABLE OF CONTENTSRC 4310 MAGNETIC TAPE STATION CONTROLLERGeneral.

RC 4310	Reference Manual	RCSL : 55 - D 55
	Timing and adjustments	RCSL : 44 - RT323
	TME 301 Indkøring	RCSL : 44 - RT750
	Polarity of Magnetic Heads	RCSL : 44 - RT033
	Handling and storage of Computer tapes	RCSL : 44 - RT291
	Interconnection plan	RCSL : 51 - VB715

TME 301.

PCBA Position Lists		RCSL : 51 - VB819
---------------------	--	-------------------

		<u>Dwg .no.</u>
RC0871-1/11	PCBA Variant	V21343
RC1609-1/1	PCBA Variant	V21236
RC1501-2	Reading Amplifier	
RC1508A-8	Read Deskew	
RC1509A-5	Test Generator and Fwd/Rev ampl.	
RC1609-1	CRC + Gate Write	
RC 1663-1	CRC Register	
RC1667-1	CRC Inverting	
RC1668A-2	Writing Amplifier	
RC1682-1	Clipping Level and + 3.6V Regulator	
RC1688A-2	Write Power	
RC1698-1	Control Gating Circuits	
	Powertraadning	V21366
	Power Wiring	V11711
	Pin positions on ELMA switch	V20850
	Test Switch Connections, Wiring Scheme	V21228
	Spændingstraadning	V21234
	Spændingstraadning	V21235
	+3.6V Regulator, Circuit Diagram	V21227

TME 301, Logic Diagrams.

MTC-200	Receivers for Control Signals	V12351
MTC-201	Test Switch, Write Power, and Test Generator Circuits	V12338
MTC-202	Control Circuits and Signal Booster	V12339
MTC-203	Data Receivers and Write Amplifiers	V12340
MTC-204	Data Receivers and Write Amplifiers	V12341
MTC-205	Data Receivers and Write Amplifiers	V12342
MTC-206	CRC Register, Write	V12343
MTC-207	Check Character Write Gate Circuit	V11413
MTC-208	Read Amplifiers and Deskew Circuits	V12344
MTC-209	Read Amplifiers and Deskew Circuits	V12345
MTC-210	Read Amplifiers and Deskew Circuits	V12346
MTC-211	Read Buffer and Transmitters	V13576
MTC-212	Control Signal Transmitters and Level Converters	V12348
MTC-213	Transmission Line Termination Circuits	V12349
MTC-214	Connector Position TME 301	V13321



TABLE OF CONTENTS:

PCBA Position List, 3 pages	Drwg. V23316
	V23317
	V23318

## Logic Diagrams:

MTC 01	Low Speed Bus Receivers and Address Decoder	V11263
MTC 02	Low Speed Receivers and Command Buffer	V11264
MTC 03	Command Decoder Circuits	V11265
MTC 04	Write Control Circuits	V13577
MTC 05	Word Cycle Counter	V11267
MTC 06	End Block Word Counter	V11268
MTC 07	Cycle Request and Overrun Circuits	V11269
MTC 08	Stop Sequence and Pseudo-Read Generators	V13578
MTC 09	Move Buffer and Start Run Circuits	V12289
MTC 10	Run Stop Circuits and End of 2	V13580
MTC 11	Timing Generator Circuits	V11273
MTC 12	Read Data Receivers and Correction Keys	V13581
MTC 13	Read Data Receivers and Correction Keys	V13582
MTC 14	Read Data Receivers and Correction Keys	V13583
MTC 15	Read Parity Check Circuits	V11277
MTC 16	Longitudinal Redundancy Check Counter Circuit	V13584
MTC 17	Read Clock Generator Circuits	V11279
MTC 18	Drop Out and Block End Detection Circuits	V13585
MTC 19	Status Buffer Circuits	V11281
MTC 20	Watch Dog Timer, Intervention, and Parity Status Circuits	V12256
MTC 21	End Address Decoder, Boosters, and Local Call Circuits	V11283
MTC 22	Pre-Erase Timing and EOT Status Circuits	V12288
MTC 23	Low-Speed Bus Transmitters	V11285
MTC 24	Low-Speed Bus Transmitters	V11286
MTC 25	Low-Speed Bus Transmitters	V12287
MTC 26	Block Size Counter Circuits	V11288

TABLE OF CONTENTS :

MTC 27	Block Size Counter Circuits	Drwg.	V11289
MTC 28	Address Counter Circuits		V11290
MTC 29	Address Counter Circuits		V11291
MTC 30	End Address Register and Comparator Circuit		V11292
MTC 31	End Address Register and Comparator Circuit		V11293
MTC 32	End Address Register and Comparator Circuit		V11294
MTC 33	Register Control Boosters, WoReg and ShReg		V11295
MTC 34	Word Register (00:11) , High-Speed Channel		V11296
MTC 35	Word Register (12:23) , High-Speed Channel		V11297
MTC 36	Data Shift Register		V11298
MTC 37	Data Shift Register		V11299
MTC 38	High-Speed Bus Receivers		V11300
MTC 39	High-Speed Bus Receivers		V11301
MTC 40	High-Speed Bus Transmitters		V11302
MTC 41	High-Speed Bus Transmitters		V11303
MTC 42	Command Transmitters		V11304
MTC 43	Write Data Transmitters and Parity Generator		V11305
MTC 44	Command Receivers		V11306
MTC 60	Error Correction control Circuits, Search and Clear		V13586
MTC 61	CRC Decoder, ErrCor Decoder, Boosters		V11308
MTC 62	Error Track Correction Pointer (ErrCor (1:9 ))		V11309
MTC 63	CRC Register		V13587
MTC 64	CRC Exclusive of OR Gates		V11311
MTC 65	Transversal Parity Error Pattern Register (PaPa(0:9))		V13588
MTC 66	Error Coincidence Detection		V11313
MTC 67	Tape Station Interface, Transmitter Terminations		V11314
MTC 68	Transit Cabling		V11315



BOSL NO: 35-155

AUTHOR : Tom Sandvang

EDITION: June 1970

**RC 4000 PERIPHERAL DEVICES**

**RC 747 AND RC 749 MAGNETIC TAPE STATIONS  
REFERENCE MANUAL**

**ABSTRACT**

This report describes the logical structure of the RC 747 seven track and the RC 749 nine track magnetic tape stations when used in connection with the RC 4000 computer.

**CONTENTS**

Main characteristics.....	page 1
Tape specifications.....	page 1
Transport times.....	page 2
Data format.....	page 2
Commands.....	page 3
Write command.....	page 4
Control command.....	page 4
Input and output.....	page 4
Erasure.....	page 6
Up-space and backspace.....	page 6
Interrupts.....	page 7
Sense command.....	page 7
Operator buttons.....	page 10
Table of status bits and operations.....	page 13

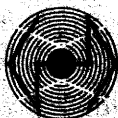

The informations in this manual are common to both the RC 747 and the RC 749 magnetic tape stations unless explicitly noted.

### MAIN CHARACTERISTICS

The magnetic tape stations operates on the high-speed data channel. They can transfer a data block consisting of a variable number of characters directly to or from the internal store.

The tape stations uses the low-speed data channel to transfer commands and control parameters to or from the working registers.

Protection keys in the internal store are neither transferred to the tape during output nor changed during input.

### TAPE SPECIFICATIONS

The tapes are compatible according to IBM, ISO, and ECMA standards.

	RC 747	RC 749
tape type	0.5 inch, 7 tracks	0.5 inch, 9 tracks
recording density	two out of the following three possibilities: 200 char/inch (density 1) 556 char/inch (density 2) 800 char/inch (density 3)	800 char/inch
tape length	2450 feet (800 m) equivalent to 5.8 mill. char. (density 1) 16.3 mill. char. (density 2) 23.5 mill. char. (density 3) without interblock gap	2450 feet (800 m) equivalent to 23.5 mill. char. without interblock gap
interblock gap	3/4 inch	0.6 inch
block length	1 to 16,383 words	1 to 21,845 words

Each reel of tape is furnished with two photo reflective marks, beginning-of-tape (BOT) and end-of-tape (EOT).

After the EOT mark, another 10 feet of tape is provided for writing data.

#### TRANSPORT TIMES

	RC 747	RC 749
start time	9 milliseconds	
stop time	9 milliseconds	
tape speed	45 inches/second	
rewind speed	180 inches/second	
transfer times	9000 char/second (density 1) 25000 char/second (density 2) 36000 char/second (density 3)	36000 char/second

The rewind time for 2450 feet of tape is about 3 minutes.

The start time is the time from the execution of an input/output command until data transfer begins at full speed. The stop time is the time from a block has been transferred until the interrupt has been delivered.

#### DATA FORMAT

The data format for the tape stations RC 747 and RC 749 is defined as follows; the information concerning RC 749 is shown in parenthesis.

The tape has seven (nine) tracks numbered t1 through t7 (t9), starting at the reference edge of the tape i.e. the top edge when viewing the oxide coated side of the tape with the beginning of the tape to the observers right. Each character recorded on the tape contains six (eight) data bits b6 (b8) through b1 and a parity bit p generated by the tape station:

RC 747	tape track	t7	t6	t5	t4	t3	t2	t1		
	character bit	p	b6	b5	b4	b3	b2	b1		
	binary weight		32	16	8	4	2	1		
RC 749	tape track	t9	t8	t7	t6	t5	t4	t3	t2	t1
	character bit	b4	b2	b8	b7	b6	p	b5	b1	b3
	binary weight	8	2	128	64	32		16	1	4

Parity: The character parity is either even or odd.

Check characters: A longitudinal redundancy check character (LRCC) is written following each block on the tape. The individual bits in the check character provide an even parity check on each track of the block.

The RC 749 tape station writes furthermore a cyclic redundancy character (CRC) between the block and the LRCC as defined in "Data Interchange on Magnetic Tape, 9 Tracks/800 BPI (ECMA/TC166/37)".

Data words: Each data word is recorded on the tape as four 6-bit characters or three 8-bit characters for the RC 747 and the RC 749 respectively:

RC 747	1. char	2. char	3. char	4. char
	0 5 6	11 12	17 18	23

RC 749	1. char	2. char	3. char
	0 7 8	15 16	23

Tape mark: A tape mark at the RC 747 is a block consisting solely of one or more characters with the decimal value 15 in even or odd parity.

At the RC 749 a tape mark is a one character block where the character have the decimal value 19 in odd parity.

This does not preclude the use of the characters 15 or 19 as a datum within non tape mark blocks.

A tape mark output in one parity and input with check of the opposite parity will always be recognized as a tape mark and will not cause a parity error indication.

#### COMMANDS

The magnetic tape stations accepts write, sense, and control commands, the sense command with two modifications and the control command with eight modifications.

In the input/output instruction specifying the write command, the contents of both the working register and the command modifications i.e. bits 18 - 21 in the effective address are irrelevant.

The use of read commands and other modifications of the control and sense commands have no effect at all.

WRITE COMMAND

A write command initiates the output of a tape mark consisting of a block which contains one character with the decimal value = 15 in even parity for the RC 747 and with the decimal value = 19 in odd parity for the RC 749.

CONTROL COMMAND

The following control commands are available:

1	set trail	<characters>
5	transfer address	<last storage address>
9	move	<move parameter>
13	input (odd parity)	<first storage address>
17	output (odd parity)	<first storage address>
21	erase	<irrelevant>
45	input (even parity)	<first storage address>
49	output (even parity)	<first storage address>

The integers denote the values of bit 18 - 23 in the effective address of the input/output instruction. The parameters in the brackets < and > denote the contents of the working register selected by the input/output instruction.

The parameters <characters> and <move parameter> are interpreted modulo 8. The <first storage address> and <last storage address> are interpreted modulo 2 097 152.

The rightmost bit in the parameters <first storage address> and <last storage address> is ignored. Thus it is irrelevant whether the parameter refers to the left or right half of the storage word.

INPUT AND OUTPUT

The input or output of a block requires two control commands:

1. A transfer command defining the last byte address in the storage buffer.
2. An input or output command defining the first byte address of the storage buffer.

Input:

Input may be terminated in two ways:

- I block size  $\leq$  storage area
- II block size  $>$  storage area

In case II a status bit is set and further input is prevented when the storage area is full. The tape motion, however, continues to next block gap.

In any case the number of characters transferred to or from the internal store is defined by the block size status word.

When the block does not contain a multiple of four characters for the RC 747 or three characters for the RC 749, the tape station fills the remaining character positions in the last storage word with NULL characters.

During input on the RC 749 tape station the cyclic redundancy character (CRC) may be used by the tape station to repair possible parity errors in a block. If a parity error indication is caused by a single-track error, the track number is computed by means of the CRC character and stored in the tape station. The erroneous block will be repaired, using this track information, when it is input again. The stored track information is cleared when one of the following conditions is fulfilled:

1. A correct block is transferred.
2. A multi-track error occurs.
3. An output operation is initiated.

To repair a possible parity error, the erroneous block should thus be backspaced and input again. Because of condition 2 above, which clears the track information, the number of attempts to re-input an erroneous block should be uneven. Persistent parity errors will then originate from multi-track errors.

Output:

Output is only possible when a write-enable ring is mounted on the back of the tape reel. If output to a tape without write-enable ring is attempted, the tape does not move, and the operation is terminated immediately.



In order to output blocks consisting of any number of characters which are not a multiple of four or three characters for the RC 747 and the RC 749 respectively, the set trail command is used. The parameter <characters> of this command determines the number of characters to be output from the last word of the storage buffer in the subsequent output operations. If <characters> is equal to zero or greater than four or three for the RC 747 and the RC 749 respectively, the full word will, however, be output.

Note: the set trail command has no effect on the input operations.

If the tape is positioned at the BOT and the output of a block is initiated, the tape will first be backspaced three inches and erased up to the BOT before the transfer of the block starts.

#### ERASURE

Erasure is only possible when a write-enable ring is mounted on the back of the reel. If erasure of a tape without write-enable ring is attempted, the tape does not move, and the operation is terminated immediately.

The erase command causes the erasure of 6 inches of tape. During erasure, the parity of the erased part of the tape is checked as a control of the quality of the tape.

#### UPSPACE AND BACKSPACE

A movement of the tape without a data transfer is initiated by a move command with one of the following move parameter values:

- 0 upspace file
- 1 upspace block
- 2 backspace file
- 3 backspace block
- 4 rewind tape
- 5 unload tape

Upspace file: The upspace file command positions the tape after the next tape mark.

Upspace block: The upspace block command positions the tape after the next block or tape mark, whichever occurs first.

Backspace file: The backspace file command positions the tape before the last tape mark or at the BOT, whichever occurs first.

Backspace block: The backspace block command positions the tape before the last data block, tape mark, or at the BOT, whichever occurs first.

Rewind: The rewind tape command positions the tape at the BOT mark.

The rewind and backspace commands have no effect when the tape is already positioned at BOT.

Unload: The unload tape command delivers an interrupt, sets the tape station local, and positions the tape at the BOT.

#### INTERRUPTS

After the initiation of every write, input, output, or tape movement command the tape station is busy until the operation is either completed successfully or terminated by an error condition. The tape station delivers always an interrupt when it becomes available. The table on page 13 shows the relations between operations, operator actions, and the interrupts.

#### PHYSICAL END OF TAPE

All forward movements of the tape may cause the physical end of the tape to be met. The tape station will in this case always be set into the local state after approximately 10 seconds, see timer status, and an interrupt is delivered.

#### SENSE COMMAND

The following sense commands are available:

- 0 sense status
- 4 sense block size

The integers denote the values of bits 18 - 23 in the effective address of the input/output instruction.

Sense block size

This command causes a block size status to be transferred to the selected working register in the following format:

zero	block size
0 7 8	23

The block size defines the actual number of characters input or output in the preceding input or output operation (excluding NULL characters filled into empty positions in the last storage word during input). In the RC 747 the counted characters are the six bit characters, in the RC 749 they are the eight bit characters. The maximum values are:

RC 747: 65 532 characters corresponding to 16 383 words

RC 749: 65 535 characters corresponding to 21 845 words

The table on page 13 shows the relations between the block size and the preceding operations.

Sense status

This command causes a status word to be transferred to the selected working register. The status word has the following format:

status	zero
0 9 10	23

The status bits have the following meaning:

- 0 intervention
- 1 parity error
- 2 timer
- 3 data overrun
- 4 block length error
- 5 EOT sensed
- 6 BOT sensed
- 7 tape mark sensed
- 8 write-enable ring sensed
- 9 high density sensed

The table on page 13 shows the relations between the status bits and the preceding operations.

Intervention: The intervention status indicates that the operator has interfered with the device by means of the local/remote switch or by opening the access door to the tape transport. The status bit will also be set after an unload tape operation and after a forward tape movement during which the physical end of tape has been met.

Parity: The parity status indicates the detection of one or more parity errors during input, output or erasure; both transversal and longitudinal parity errors are detected. It may also signify an attempt to write a NULL character with even parity and in this case the output is terminated immediately. The parity status is not set when a tape mark is input with the check of any parity.

Timer: The timer status indicates the termination of an input operation during which empty tape has been sensed for more than approximately 10 seconds or that the physical end of the tape was met during a forward movement of the tape. The timer status will also be set when the operator sets the tape station in the local state if a possible operation is not finished within approximately 10 seconds, see operator buttons.

Data overrun: The data overrun status indicates the loss of one or more data words during input or output due to overloading of the high-speed data channel. During input the tape motion is continued to the next block gap.

Block length error: The block length status indicates an attempt to input a block which is too large for the storage area; in this case the size in the block size status word is equal to the size of the storage area. The tape movement continues to the next block gap.

EOT sensed: The EOT status is set whenever the EOT mark is passed during input, output, and upspace operations. The status remains set until the EOT mark is passed during the unload, rewind, or backspace operations.

BOT sensed: The BOT status is set as long as the tape is positioned at the BOT mark.

Tape mark sensed: The tape mark status is set whenever a tape mark is passed during the input, output, write, backspace, and upspace operations. The status is cleared by the next control or write operation.

Write-enable ring sensed: The write-enable status is set permanently when the tape reel is mounted with a ring.

High density sensed: The high density status is set permanently when the operator has selected the high density by means of the operator button HI/LO.

#### OPERATOR BUTTONS

The tape stations are supplied with eight push-buttons which are placed in two groups. The buttons in the upper group are only active when the tape station is in the local state, whereas the buttons in the lower group always are active.

The push-buttons are named:

Lower group: HI/LO, LOCAL, REMOTE, POWER

Upper group: RESET, REWIND, REVERSE, FORWARD

An indicator called FILE PROTECT shows light when no write-enable ring is mounted on the tape.

LOCAL and REMOTE: Combined push-buttons and indicators. The operator can by means of these buttons select between the local state and the remote state. In the remote state the tape station is program controlled. In the local state the operator may mount a tape reel and perform control functions by means of the buttons in the upper group.

Switch from the remote to the local state: If the operator switches to local and the tape station is available, the local state is entered immediately. If, however, the operator switches to local during a data transfer or a tape movement, the transition to the local state is delayed until either the operation has been completed or a time interval of approximately 10 seconds has elapsed, whichever occurs first. The operation is in any case terminated by an interrupt and the device becomes available before the local state is entered.

Local state: When the tape station becomes local the intervention status bit is set and if the above mentioned elapse of time has caused the termination of a possible operation the timer status bit will also be set. The status bits remain set until until the next control operation is initiated in the remote state (but not when initiated in the local state).

If a command involving a data transfer or tape movement is initiated in the local state, the station accepts the command and becomes busy. The actual operation is, however, delayed until the operator switches to remote control

Switch from the local to the remote state: When the operator switches from local to remote control, the tape station may be available if no operation has been initiated in the local state, or it may be busy if an operation has been accepted but delayed in the local state.

If the station is available it delivers an interrupt immediately when the remote state is entered. However, if the station is busy, it enters the remote state and completes the operation before delivering the interrupt.

Local and remote indicators: The local and remote indicators can give the following information:

1. Neither the LOCAL nor the REMOTE indicator shows light:
  - The power for the tape station is switched off, or
  - A tape is not mounted, or
  - A tape is mounted erroneously.In all three cases the tape station acts as if in local state.
2. The LOCAL indicator shows a white light:
  - The tape station is in the local state.
3. The REMOTE indicator shows a white light:
  - The tape station is in the remote state.
4. The REMOTE indicator shows a red light:
  - The tape station is still in the local state because of a hardware error.

HI/LO: Combined push-button and indicator. The button selects between high and low recording density. The selected density is showed by the indicator. On the RC 749 the low density should not be used, as it selects a non-standard density.

POWER: Combined push-button and indicator. The button switches the power on and off for the tape station. The power state is showed by the indicator. When power is switched off, the tape station is considered to be in the local state, i.e. the disconnected bit will not be set in the exception register.

FORWARD: The forward button starts a forward search for a BOT mark.

REVERSE: The reverse button starts a backward search for the BOT mark. The tape is unwound if it is positioned on or below the BOT mark.

REWIND: The rewind button starts a fast backward search for the BOT mark. The tape is unwound if it is positioned below, but not on the BOT mark.

RESET: The reset button stops a tape movement which is initiated from one of the other operator buttons, so a new tape movement can be started. The button must always be used between two tape movements initiated from the operator buttons.

Caution: The reset button will also stop the tape movement when a programmed rewind operation is executed in the remote state, and the tape station will then remain in the remote state. Thus the operation will never be finished.

#### TAPE TRANSPORT ACCESS DOOR

If the access door to the tape transport is opened while the tape station is in the remote state, a possible data transfer is terminated. A possible tape movement operation is terminated immediately, leaving the tape in an undefined position. The tape station then becomes local and the intervention status bit is set; if the timer bit also is set, the remaining status bits are undefined. Opening of the access door in the remote state is therefore an irregular way to set the tape station into the local state and should be avoided. The remote state can be entered again as described under the LOCAL and REMOTE buttons.

operations and operator intervention	status bits										block size result	interrupt	operation terminated by error
	intervention	parity	timer	data overrun	block length error	EOT sensed	BOT sensed	tape mark sensed	write-enable-ring	high density			
	0	1	2	3	4	5	6	7	8	9			
write command (tape mark)	a, b		b, c				1		e		1		k, h
Input odd	a, b		b, c				1				cha		f, h
input even	a, b		b, c				1				cha		f, h
output odd	a, b		b, c				1		e		cha		f, k, h
output even	a, b		b, c				1		e		cha		f, g, k, h
erase	a, b		b				1		e		0		k, h
upspace file	a, b		b, d				1				0		h
upspace block	a, b		b, d				1				0		h
backspace file	a, b		d								0		h
backspace block	a, b		d								0		h
rewind	a, b										0		h
unload											0		h
press local button		i	d	i	i	i	i	i			i		
press remote button		i	i	i	i	i	i	i			i		
open access door		u	u	u	u	u	u	u			u		

- a: if local state entered.
- b: if physical end of tape met or after certain hardware failures.
- c: if operation lasts longer than appr. 10 seconds and not in local.
- d: if local selected and operation not terminated within appr. 10 seconds.
- e: must be present.
- f: if data overrun.
- g: if NULL character output.
- h: if tape transport access door opened.
- i: depend on previous action.
- k: if no write-enable-ring mounted.
- l: if irregular tape position. Information on tape at BOT-mark.
- u: undefined.
- : absolutely certain that the event in question will occur.
- : the event may occur (circumstances not specified).
- cha: number of transferred characters.



RCSL : 44-RT 323

pp. 7

Author : JØG

Edited : November 1969

TIMING CIRCUITS ADJUSTMENT

MTC 402

---

A/S REGNECENTRALEN

1, Falkoneralle

2000 Copenhagen F.

CONTENTS :

	page.
A. Internal Clock Generator .....	1
B. One Shot Circuits and Delay Circuits .....	3
C. Precision Adjustments	

### A. Internal Clock Generator

The internal clock originates from a crystal controlled oscillator working at 1.800 kHz. The oscillator output is modified by a bistable (circuit 30B, position 52) followed by two delay circuits (circuits 50C and 50D, position 1) to generate a two-phase clock :

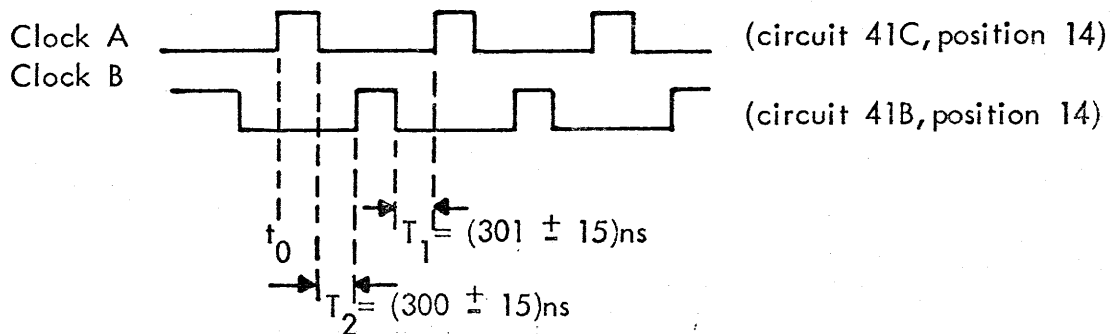

Fig. 1. Time adjustments of internal clock.

The clock signals appear at circuits 41C (clock A) and 41B (clock B), position 14, and must be adjusted in this way :

- 1) A double-beam oscilloscope is triggered at time  $t_0$  (fig. 1) and clock A and clock B are traced with the two beams.
- 2) The time  $T_1$  is adjusted to  $(300 \pm 15) \text{ ns}$  by the potentiometer in circuit 50C, position 1.
- 3) The time  $T_2$  is adjusted to  $(300 \pm 15) \text{ ns}$  by the potentiometer in circuit 50D, position 1.

This adjustment affects most of the controller functions and should be checked especially when sporadic errors occur in the data handling or tape move circuits. Be sure that your oscilloscope time base is precise. Check against oscillator period:  $1111 \pm 2 \text{ ns}$  at circuit 30B, position 52.

The write timing at different speeds and densities is generated by a counter circuit 70A, position 92, and a decoder circuit 71A, position 94. The decoding circuit is switched electronically to select proper character rate, and the rates are set up by a select-by-soldering switch, giving the constant N in the expression :

$$f_w = f_{osc} / (2 * (N+1) );$$

$f_w$  is the resulting write frequency and  $f_{osc}$  is the base oscillator frequency (1800 kHz).

In the select-by-soldering switch each bit of the two values of N has a field with 6 holes, which may be connected to true (1) or false (0). Fig. 2 shows the set-up for the bit with weight 8 connected to true in the number A and to false in the number B.

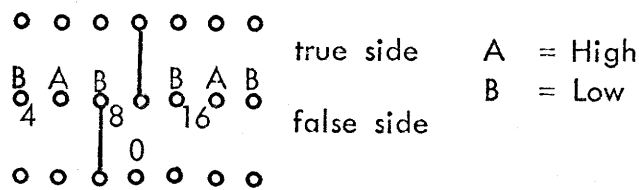

Fig. 2 Set-up for the value N in write clock generator.

The table below gives set-up numbers corresponding to some write frequencies commonly used :

SPEED (IPS)	45			36,3		
	Density (bpi)	200	556	800	200	556
fw (kcps)	9.00	25.0	36.0	7.26	20.5	29.0
period (usec)	111	40.0	27.8	138	48.8	34.5
N set-up	99	35	24	123	43	30

The write clock has two phases and may be checked by connecting a double-beam oscilloscope to the circuit 05M, position 20 (write clock A) and 03M, position 17 (write clock B). The two phases should occur as shown on fig. 3.

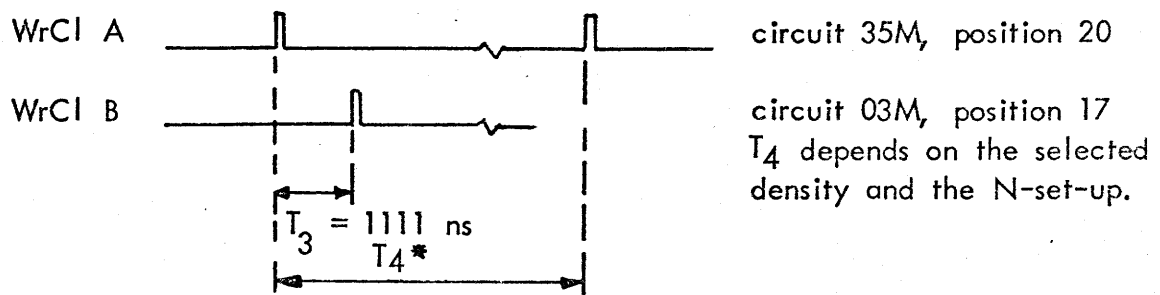

Fig. 3. Write clock timing.

## B. One Shot Circuits and Delay Circuits.

The sequence timing in the controller includes 6 one-shot circuits which are most preferably adjusted by activating the controller from a test program, consecutively performing the loop :

```
begin
start :      erase;
           backspace block;
           go to start;
end;
```

The program will activate the timing circuits listed below and they are adjusted following the list from 1 through 6.

Step:	Name, purpose	Cir- cuit.	Pos:	Time		Notes :
				(45, 0ips)	(36, 3ips)	
1.	Run Trig	46B	95	$(200 \pm 100)ns$	$(200 \pm 100)ns$	
2.	Erase Overlay	46A	95	2 ms	ca. 2 ms	Delays station operable.
3.	Write Current Rise Time	45C	54	$(1,5 \pm 0,1)ms$	$,5 \pm 0,1)ms$	Preferable compare with actual rise time in TME!
4.	Direction Settle *)	45D	54	$(10 \pm 1)\mu s$	$(10 \pm 1)\mu s$	Ampex logic requires delay of RUN after direction change.
5.	Tape Start Delay	45B	54	$(11,5 \pm 1)ms$	$(15 \pm 1)ms$	This may change due to later adjustments.
6.	Tape Stop Delay	45A	54	$(9 \pm 0,2)ms$	$(11 \pm 0,2)ms$	Be shure tape does not move after this time.

\*) Preliminary restrictions will require this time to be at least 0,5ms!

Fig. 4.

Whenever possible the preferred values given above should be obtained. Limits must be respected with at least 5 pendent screw turns on potentiometer.

The continuity supervision circuit 69A, position 2, must be time matched to the tape speed and packing densities used, before adjustments can be performed.

The component values and nominal times are given in the table, appendix A.

A course adjustment of the circuit is performed in this way :

- 1) The controller is activated to write data clocks including 3 characters + CRCC + LRCC.
- 2) A double-beam oscilloscope is triggered - and one beam traced - on the first appearing read strobe on circuit 95K, position 56, and the monostables of the continuity supervision circuits are observed by the other beam.:
- 3) The time  $T_A$  (fig. 5) is adjusted to nominal value. Use testpoint H, position 2.
- 4) The time  $T_B$  (fig. 5) is adjusted to nominal value. Use testpoint G, position 2.

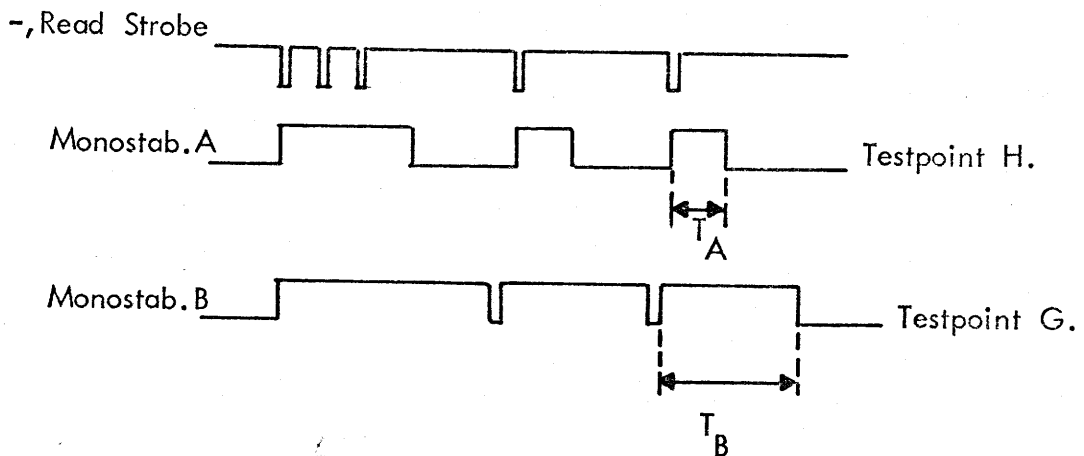

Fig. 5 Continuity Circuits Timing

During the write operation mentioned above, the following delay circuits may be adjusted :

- 1) The CYS Overlap circuit 50B, position 1 is adjusted to obtain  $(1.5 \pm 0.5)$ usec overlap from the leading edge of output from circuit 50B.

- 2) The LRCC pick-up time, circuit 50A, position 1, is adjusted to obtain  $600 (\pm 20)$  usec delay from the leading edge of output from circuit 69A, testpoint C, position 2, and the trailing edge of output from circuit 50A.

The reverse delay adjustment is performed by activating the controller from a program performing write and backspace block operations consecutively. The circuit 46C, position 95, is activated at the end of each backspace operation and the delay is adjusted to  $(6.67 \pm 0.10)$  msec at 45 ips tape-speed and  $(8.27 \pm 0.10)$  msec at 36.3 ips.

It should be checked that the tape creeps slowly forwards during this operation (appr. 5 revolutions per minute of the capstan at blocklengths less than 5 words). This is obtained by properly increasing the Tape Start Delay.

With the continuity supervision circuits adjusted - following the coarse adjustment procedure given above - it is possible to perform proper writing on the tape. So, to perform fine adjustment of the continuity supervision circuits, a scratch tape reel is filled with data blocks containing arbitrary data, e.g. all ones. When the tape reel is full (EOT reached) the adjust procedure proceeds as follows :

- 1) Switch to "Adjust" state by the thumb switch on circuits 69A, position 2.
- 2) Initiate an upspace block operation.  
NOTE : The tape moves continuously and can be stopped only by switching to the "Normal" state by the thumb switch.
- 3) A double-ray oscilloscope is triggered by the monostable B on circuit 69A, position 2, testpoint G.
- 4) The read strobe signal 95K, position 56, testpoint K, is traced by one beam, and the monostable A, position 2, testpoint 11, is traced by the other. The monostable A is adjusted to have its trailing edge positioned as shown on fig. 6.

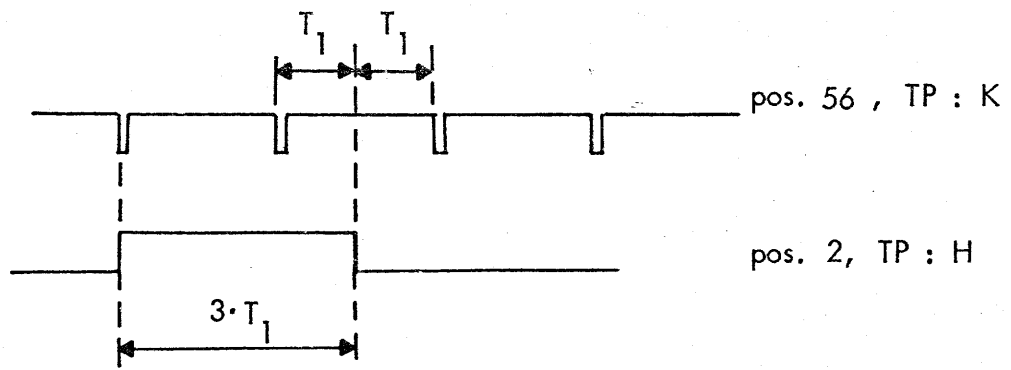

Fig. 6 Adjustment of the monostable A.

- 5) The second beam is connected to testpoint G, position 2, (same as trigger) to trace the monostable B, which is adjusted to have its trailing edge positioned as shown on fig. 7.

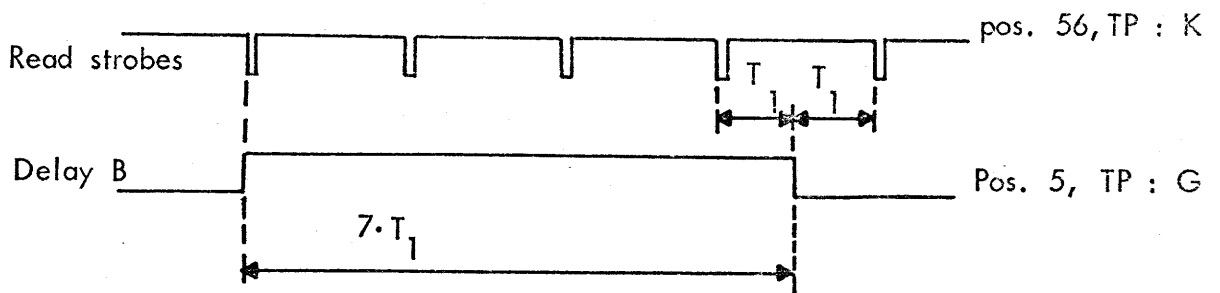

Fig. 7 Adjustment of the monostable B.

- 6) Switch to "Normal" mode.

The entire procedure, including the generation of the test tape, must be performed for high and low density as well.



RC0911-1 Variant NO	R <sub>1</sub> =R <sub>2</sub>	Component				Application		Times			
		C1 (pF)	C2 (pF)	C3 (pF)	C4 (pF)	Density (BPI)	Speed (IPS)	Hi density		Lo density	
								A (us)	B (us)	A (us)	B (us)
/1	10K	-	4K7	1K0	10K	200/556	45	60.0	140	167	388
/2	6K2	-	4K7	1K0	10K	200/800	45	41.5	97.0	167	388
/3	27K	470	1K0	680	3K3	556/800	45	41.5	97.0	60.0	140
/4	10K	1K0	4K7	3K9	10K	200/556	36.3	72.2	171	206	481
/5	6K2	1K0	4K7	3K9	10K	200/800	36.3	51.7	121	206	481
/6	27K	680	1K5	510	4K7	556/800	36.3	51.7	121	72.2	171

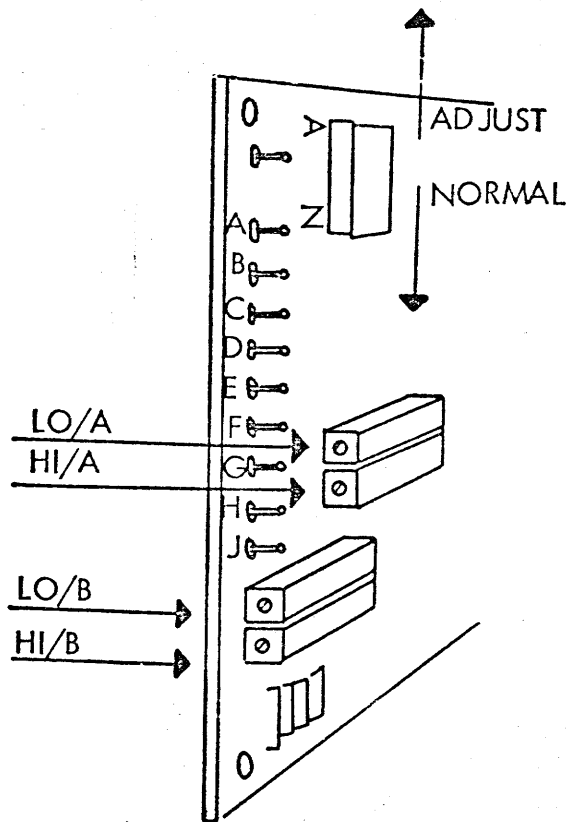

A/S REGNENCENTRALEN

Designed by  
1271-22/503

Drawn by

Dwg. Office Check

Design Check

Replaces Dwg. No.

due to ECN

Replaced by Dwg. No.

Unit  
MTC 602

Dwg. No.

Timing Diagram  
End of Block, CRC=0

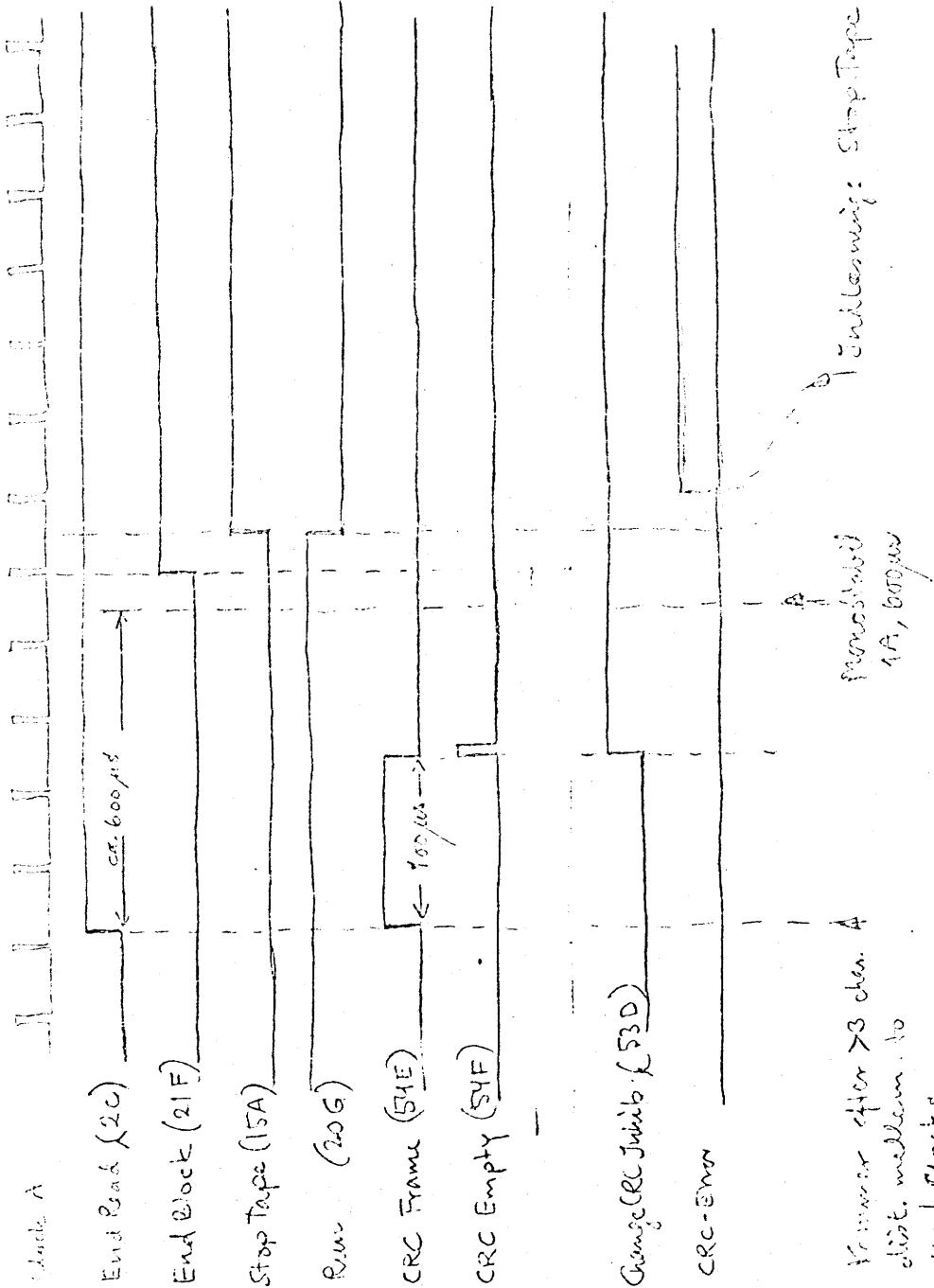

TIMING, BLKSLUT VED CRC=0

RCSL: 44 - RT - 750

Authors: JØG/PEH

Edited:

Concept / 7.4.1970

## TME 301 INDKØRING

Tips og vejledning

Keywords: RC 4000/TME 301

A/S Regnecentralen

## INDHOLD

Afsnit	Side
1. AMPEX TM-7 TAPE TRANSPORT	3
1. 1. Modifikationer	3
1. 2. Afprøvning	3
2. SKRIVE/LÆSE ENHED, TME 301	4
2. 1. Funktioner	4
2. 2. Justeringer og afprøvning	6

## 1. AMPEX TM-7 TAPE TRANSPORT

### 1.1 Modifikationer

I dette og i de følgende afsnit forudsættes et vist teknisk kendskab til Ampex TM-7 Tape Transport, idet denne vejledning primært beskæftiger sig med afvigelser fra normale funktioner.

Når Ampex TM-7 indgår i magnetbåndstationen RC 749, er der foretaget ændringer på følgende punkter:

1.1.1. De øverste trykknapper (Reset, Rewind, Reverse, Forward) er passive, når TM-7 er i REMOTE mode (knap REMOTE lyser). Undtaget er dog RESET-knappen, der fungerer under rewind-operationer, også i REMOTE mode. Ændringen er vist på figur 1.

1.1.2 I RC 4000 systemer kræves nøje kontrol med jord- og chassisforbindelser, der er isoleret fra neutral-ledere i elektronikkredsløbene (0 V) alle andre steder end i centralenheden. For TM-7 betyder dette, at forbindelsen mellem bånd-dæk og skrive/læse hovedets skærm må brydes, samt at strappen mellem TS1-11 og TS2-4 på Transport Power Supply (Capstan Grd. til Chassis Grd.) må fjernes.

1.1.3 Det har vist sig hensigtsmæssigt at lade stationen slette båndet et stykke udenfor (før) BOT-mærket, og det betyder, at stationen skal kunne køre baglæns fra BOT også i REMOTE mode. Derfor er følgende ændret på PCBA-FLA i TM-7: Diode CR24 er fjernet. Der er lagt forbindelse fra stikben 12 (RUN/STOP) til den 'kolde' ende af R18. Se figur 2 og 3, samt eventuelt manualen for TM-7.

### 1.2 Afprøvning

Der etableres forbindelser (korte ledninger med elco-ben) mellem ben S og MM og mellem T og U på stikket P3, der via kabel er forbundet til P10 på TM-7.

1.2.1 Stationen tilsluttes 220V, og der tændes. Et arbejdsbånd monteres (se evt. manualen for TM-7), idet stationen betjenes på sædvanlig vis. Alle trykknapp-funktioner afprøves, og det påses, at stationen opfatter BOT, og at kørsler fremad, tilbage og hurtigt tilbage kan udføres.

1.2.2 Fjernes forbindelsen mellem S og MM på P3, har de fire øvre trykknapper ingen virkning ( se dog pkt. 1.1.1 ), men der kan stadig skiftes mellem LOCAL og REMOTE mode. Fjernes forbindelsen mellem T og U på P3, bliver også LOCAL-knappen uden virkning.

## 2. SKRIVE/LÆSE ENHED, TME 301.

### 2.1 Funktioner.

Skrive/Læse Enheden TME 301 omsætter digital information fra MTC402 til strømme, der er tilpasset skrivehovedet på TM-7, og den opsamler low-level signaler fra læsehovedet på TM-7 og omsætter dem til digital information, der sendes til MTC402.

Se figur 4. Endvidere fungerer TME301 som niveau-omsætter for en del kontrolsignaler i kommunikationen mellem TM-7 og MTC402. En omskifter muliggør off-line justeringer og afprøvning af TM-7 og TME301. Enheden strømforsynes dels fra TM-7 Logic Supply, og dels fra MTC402.

2.1.1 Skrivekredsløb. Skrivning på magnetbåndet sker efter NRZI metoden.<sup>x)</sup>

Data sendes karaktervis ( 9 bits parallel ) fra MTC402 til TME301 via snoede par og opfanges af modtagerkredsløbene i position 43. Fra modtagerne går signalerne til 9 skriveforstærkerkredsløb, position 31 - 39, et for hvert spor ( h.h.v. bit i karakteren ). Spalterne i skrivehovedet vil i praksis aldrig ligge på samme normal til båndets bevægelsesretning, og en karakter, der skrives på én gang ( strømændring i alle spor samtidigt ), vil derfor 'brede sig' i båndets længderetning ( se figur 5). Skriveforstærkerkredsløbene i TME301 er udstyret med 'deskew' -funktion, der udnytter sammenhængen mellem vejlængde og tid ved jævn bevægelse til at kompensere for skrivehovedets ufuldkommenhed i denne retning. Af beregningerne på figur 5 fremgår, at man ved en individuel forsinkelse af skrivningen af karakterens bits kan opnå at placere alle bits på én normal. Udnævnes den spalte, der først passerer af referencenormalen, til referencespalte, skal skrivningen i de øvrige spor forsinkes med tiden  $ssi/vT$ , eller den fysiske afstand mellem referencespalte og aktuel spalte divideret med båndhastigheden. Ved 45 ips kræver en spalteafstand på  $10^{-6}$  meter en forsinkelse på ca. 1 mikrosekund.

x) d.v.s. den magnetiske flux på båndet skal ændre polaritet på langs ad båndet, når en bit har værdien sand, og forblive uændret, når en bit har værdien falsk.

Vedrørende justering: se pkt. 2.2.3. Bemærk, at forudsætningen for, at 'deskew' justeringen virker efter hensigten, er at båndhastigheden er nøjagtig og konstant. Strømretningen i skrivehovedets spoler styres af 7 bistabile, der skifter tilstand (efter 'deskew' -forsinkelsen), hvis deres respektive datalinie er sand. En nulstillingsindgang anvendes til at sikre, at alle strømme går i samme retning, når skrivningen af en blok er afsluttet. Nulstillingen viser sig på båndet som en karakter, LRCC eller Longitudinal Redundancy Check Karakter, og tidsmæssigt styres den af kontrolenheden, MTC402.

2.1.2 Læsekredsløb. Læsesignalerne fra TM-7 kommer som balancerede signaler med en spænding på ca. 15 mVpp. I 9 forstærkere (positionerne 1-9) sættes niveauet op til ca. 5 Vpp, og signalerne sendes til de kombinerede detektor/-'deskew'/buffer kredsløb (i positionerne 21-29). Detektorkredsløb har et dødt bånd, hvis bredde er afhængig af, om der skrives eller læses. Ved skrivning, hvor læsning foretages til kontrol af det skrevne, skal signalet fra forstærkeren være  $\geq 2$  Vpp, før det detekteres - ved læsning  $\geq 1$  Vpp. På figur 6 er vist nogle karakteristiske signaler. Også på læsehovedet er der afvigelser fra den ideelle placering af spalterne, og der indføres 'deskew' forsinkelser også ved læsning. En karakter, der er korrekt placeret på båndet, kan være repræsenteret ved s0 på figur 5. Bit 'i' vil blive læst  $ssi/vT$  senere, og karakteren kan læses som "samtidig", hvis sporene aftastes efter tiden  $t_i = tR - ssi/vT$ . Efter 'deskew' forsinkelsen læses en bit ind i en opsamlingsbuffer, og den først ankomne bit (efter 'deskew' forsinkelse i karakteren aktiverer tidskredsløbene (se 2.1.4). Gennem et 9-bit bufferregister (position 45) sendes karakteren senere fra senderkortet (position 46) via snoede par til MTC402.

2.1.3. Tidskredsløb. Den først ankomne bit i opsamlingsbufferen aktiverer en trigger (i or-funktionen) med en pulslængde på ca. 0.5 mikrosekund, der starter opsamlings-tiden, givet ved monostabile A og B på position 44 (se diagram MTC202). På bagkanten af opsamlings-tids-impulsen startes en transfer-impuls på ca. 1 mikrosekund, der overfører data til senderbufferen og nulstiller opsamlingsbufferen. Efter transfer-impulsen afsendes en strobe, der melder, at der er data på sender-linierne til MTC402. Figur 6 viser forløbet ved læsning af to karakterer.

2.1.4 Kontrolkredsløb. TME301 tilslutter og afbryder skrive- og slettestrømme styret fra MTC402 på betingelse af, at skrivering findes på båndspolen. De variable 'deskew' kredsløb i læsedelen skal have forskellige forsinkelsestider afhængig af, om båndet kører forlæns eller baglæns, og dette styres fra et kredsløb i position 12, hvor også generatoren til off-line skrivning (af karakterer med lutter 1'er) findes. Vedr. øvrige kontrolfunktioner henvises til logikdiagrammer og manual for TME301.

## 2.2 Justeringer og afprøvning.

Ved justering af kredsløbene i TME301 benyttes følgende hjælpemidler:

- 1) Et <Master Skew Alignment Tape> (tæthed ukritisk).
- 2) Et arbejdsbånd af god kvalitet. Dette er kritisk ved justering af skrive-'deskew'.
- 3) Et dobbeltstråle-oscilloskop.
- 4) Et universalmeter, 20 kohm/volt eller bedre.

Justeringerne foretages i den anførte rækkefølge, idet et punkt først forlades, når det er udført med et resultat som angivet. Ved justeringen skal de angivne nominelle værdier så vidt muligt opnås. Grænseværdier skal kunne overholdes, uden at potentiometret bringes nærmere end 2 omdrejninger fra en yderstilling. I modsat fald må der udskiftes komponenter i de pågældende kredse.

2.2.1 DC-Regulering. For at tilvejebringe +3.6V DC til de anvendte RTL-kredse i TME301 findes i position 12 en reguleringsforstærker, som styrer en transistor, Q1, igennem hvilken +12V fra Ampex Logic Supply reduceres til +3.6V. Med et universalmeter mellem 0V og TP1 indstilles med øverste potentiometer spændingen til  $(3.6 \pm 0.1)V$ .

2.2.2 Klippeniveau. På TP2, position 12, kan med et universalmeter måles den spænding, som giver læsedektorens døde bånd. Ved hjælp af tekniker-omskifteren sættes TME301 i læse-tilstand, og klippespændingen justeres med nederste potentiometer til  $(0.50 \pm 0.05)V$ . Med tekniker-omskifteren i skrivestilling justeres med midterste potentiometer klippespændingen til  $(1.0 \pm 0.1)V$ .

2.2.3 Skrive-Generator. På TM-7 vælges LOW DENSITY, og med oscilloskopet betragtes på position 11, TP1, korte pulser, der anvendes ved off-line skrivning. Afstanden mellem pulserne justeres v.hj.a. nederste potentiometer til  $(112 \pm 10)$  mikrosekunder. Øverste potentiometer er aktivt, når HIGH DENSITY er valgt, og om ønsket kan puls-afstanden justeres til ca. 28 mikrosekunder (svarende til 800 bpi) eller mindre.



2.2.4 Capstan Opretning. Det er af største vigtighed af hensyn til skånsom båndbehandling og kompatibilitet mellem stationerne, at båndføring over skrive/læsehoved og capstan er i orden. Inden justeringer i TME301 kan ske, foretages derfor følgende:

- 1) Et <Master Skew Alignment Tape> monteres uden skriver. Oscilloskopet forbindes til udgangen af læseforstærkeren i position 1 og 9 (testpkt. 1), idet der trigges på en af kanalerne.
- 2) Tryk FORWARD og iagttag oscilloskop-billedet. Vælg evt. følsomhed 0.5V/cm og brug positionskontrol, så billedet ligner figur 7. Vandret akse vælges 2-5 mikrosek/cm.
- 3) Skift til REVERSE og kontroller, at det spor, der i 2) kom sidst, nu ligger forrest - og så vidt muligt med samme (minimale) skew. Billedet skal stabiliseres straks efter, at båndretningen er skiftet.
- 4) Skift til FORWARD, ellers som 3). Derefter repeteres 3) og 4) nogle gange, og når billedet hver gang er stabilt straks, og den konstaterede 'skew' tid er < 5 mikrosek. såvel forlæns som baglæns, kan pkt. 2.2.1 i betragtes som afsluttet. I modsat fald: se 5).
- 5) Løsn de tre skruer, der holder capstan-motoren mod bånd-dækket. Løft let i capstan-motorens fastgørelsesplade, idet 3) og 4) repeteres. Ved at løfte i de tre hjørner efterhånden opsøges det hjørne, hvor 'skew'-tiden bliver mindre end ved forsøget.
- 6) Et stykke metalfolie (tykkelse: 0.2mm) lægges under anlægget i det ved 5) fundne 'hjørne', og skruerne spændes. Der fortsættes med 3).

ADVARSEL: Det må anses for betænkeligt, dersom den ovenfor nævnte justering ikke eller kun med stort folieforbrug lader sig gennemføre. Undersøg båndjern for løse eller skæve komponenter, og.....

2.2.5 Læsekredse. I læsekredsene er der tre justeringer, nemlig læseforstærkerens forstærkning, 'deskew' -forsinkelser forlæns og 'deskew' -forsinkelser baglæns.

- 1) Monter et arbejdsbånd med skrivering. Vælg LOW DENSITY. Sæt tekniker-omskifteren i skrive-stilling og kørs fremad.

- 2) Med oscilloskopet betragtes efterhånden de ni læseforstærkeres udgangssignal, og der justeres med potentiometrene til  $(5.6 \pm 0.2)V_{pp}$ , hvilket skal kunne ske uden synlig forvrængning af kurveformen. Derefter justeres tilbage til  $(5 \pm 0.2)V_{pp}$ , som er den endelige værdi.
- 3) Udskift arbejdsbåndet med et <Master Skew Alignment Tape> uden skrivering. Vælg HIGH DENSITY. Sæt tekniker-omskifteren i læse-stilling og køør for læns.
- 4) Lad oscilloskopet trigge på detektor-udgangen for midterste spor, position 25, TP4, og betragt med den ene stråle dette signal.
- 5) Med den anden stråle betragtes efterhånden de øvrige spors detektor-udgange (positionerne 21-29). Hvis et spor har et senere detektor-output end det spor, der trigges på, flyttes triggeren til det seneste, og 5) gentages.
- 6) Den triggede stråle på oscilloskopet flyttes til TP2 på den i 5) opsøgte position, og 'deskew' -forsinkelsen i dette spor justeres til  $(3 \pm 1)$  mikrosekund ved hjælp af øverste potentiometer.
- 7) Med den anden stråle betragtes efterhånden de øvrige 'deskew' -forsinkelser. Der justeres med nederste potentiometer, så bagkanterne er så vidt muligt sammenfaldende. Vær opmærksom på puls-parrings fænomener - brug eventuelt addition af de to signaler til kontrol af målingens pålidelighed. Se figur 8 a) og b).
- 8) Herefter etableres en kortslutning mellem TP2 og TP3 på position 11, hvorved læsekredsene bringes i 'baglæns' tilstand. Båndet køør REVERSE fra EOT, og justeringsprocedurens punkter 4), 5), 6) og 7) udføres med alle justeringer foretaget med øverste potentiometer i stedet for nederste. Derefter fortsættes med punkt 9).
- 9) Fjern kortslutningen mellem TP2 og TP3 på position 11.
- 10) Inden det anvendte 'Master Skew Alignment Tape' fjernes fra station, skal det spoles frem til EOT og derpå uøntastet spoles tilbage (Rewind kan anvendes). Derpå kan båndet afmonteres.

2.2.6 Skrivekredse. I skrivekredsene skal kun 'deskew' -forsinkelsen justeres.

- 1) Monter et arbejdsbånd med skrivering og lad det køre fremad med teknikeromskifteren i skrivestilling. Brug LOW DENSITY af hensyn til 2.2.7.
- 2) Lad oscilloskopet trigge på detektor-udgangen formidterste spor, position 25, TP4, og betragt med den ene stråle dette signal.
- 3) Med den anden stråle betragtes efterhånden de øvrige spors detektor-udgange (positionerne 21-29). Hvis et spor har et senere detektor-output end det spor, der trigges på, flyttes triggeren til det seneste, og 3) gentages.
- 4) Når senest ankomne spor er funder, justeres skrive-'deskew' -forsinkelsen i dette spor med potentiometeret på skriveforstærkeren (position 31-39) til  $(3 \pm 1)$  mikrosekunder. Trig på - og betragt - forsinkelsestiden på testpunkt på den aktuelle skriveforstærker (position = læsedeskew pos. + 10).
- 5) Lad atter oscilloskopet trigge på detektor-output fra det seneste spor, og juster 'deskew' -forsinkelsen på de øvrige skriveforstærkere, så ankomsten er så vidt muligt samtidig for alle spor.

2.2.7 Opsamlingstid.

Opsamlingstiderne justeres til overensstemmelse med denne tabel:

Density:	800	556	200	800	556	200	bpi
Speed:	45	45	45	36	36	36	ips
Skrivning:	6.0	10.0	35.0	8.5	15	40	us
Læsning:	16	23	64	20	30	80	us

Der justeres til højeste anvendte tæthed.

Mål på pos. 44 TpA juster pot 1 til 6 us

Mål på pos. 44 TpB juster pot 2 til 16 us

Mål på pos. 44 TpC juster pot 3 til 0,1 us

Mål på pos. 44 TpD juster pot 4 til 5 us.

T-SEKTOR

A/S REKNOCENTRALEN

141169PTN

Office Check Design Check

2607770A

Design Office

V21121

NO.	DESCRIPTION	DATE	APPROVED BY
1	A ERN 193-2		

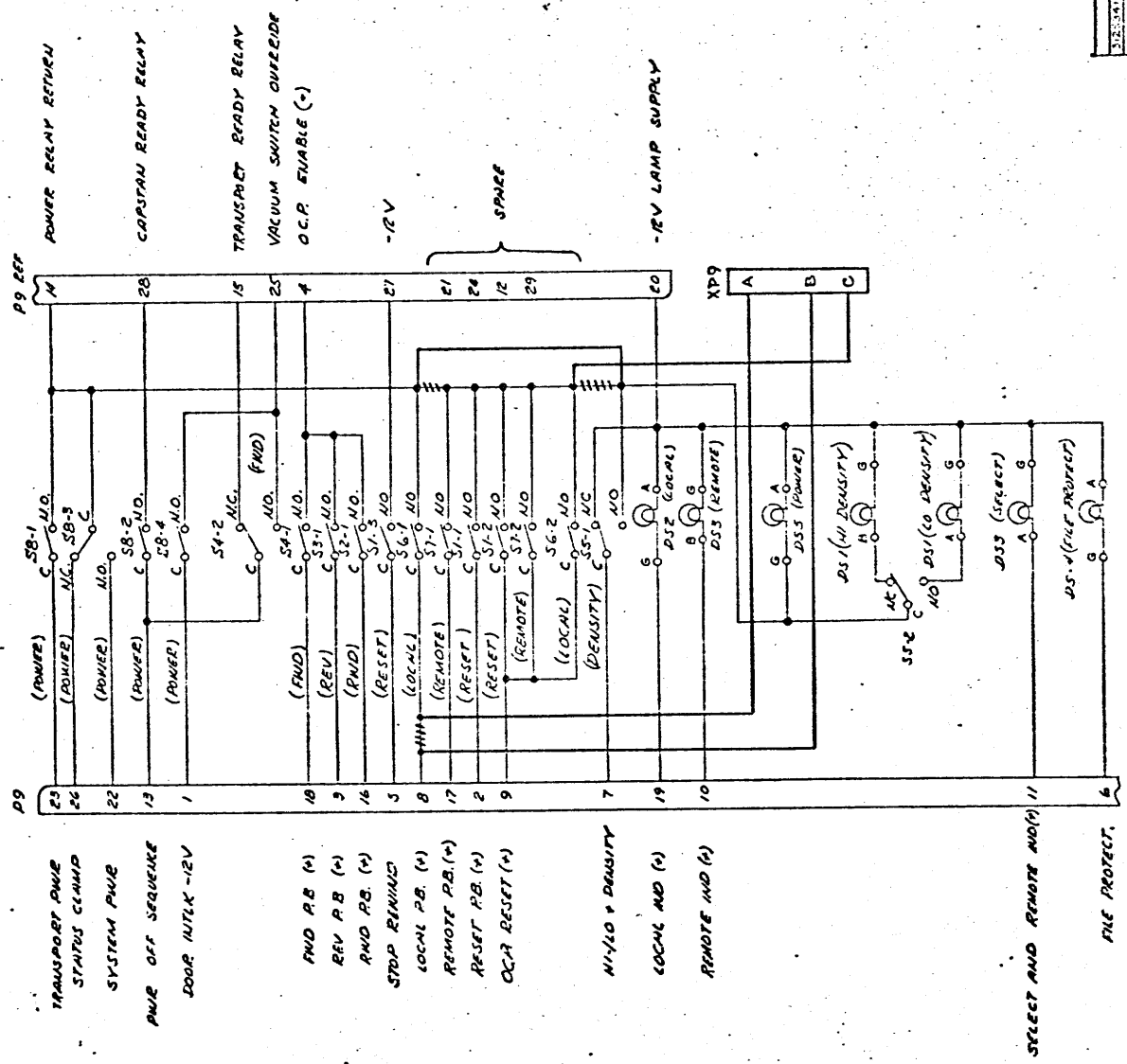

NOTES:  
1. FOR WIRE LIST SEE 3125330.

NO. OF SHEETS	1
TOTAL NO. OF SHEETS	1
DATE	1971-07-15
BY	TOP-100/DM
CHECKED	
APPROVED	
AMPEX CORPORATION	
SCHEMATIC	
OPERATOR CONTROL PANEL	
STANDARD	
PROJECT NO.	D 09150
DRAWING NO.	3125339

Fig. 1

Diagram for Operator Control panel med ændring for tilslutning af stik XP9.

Nyt hul bores, så den lange lus kan forbindes til ben 12.

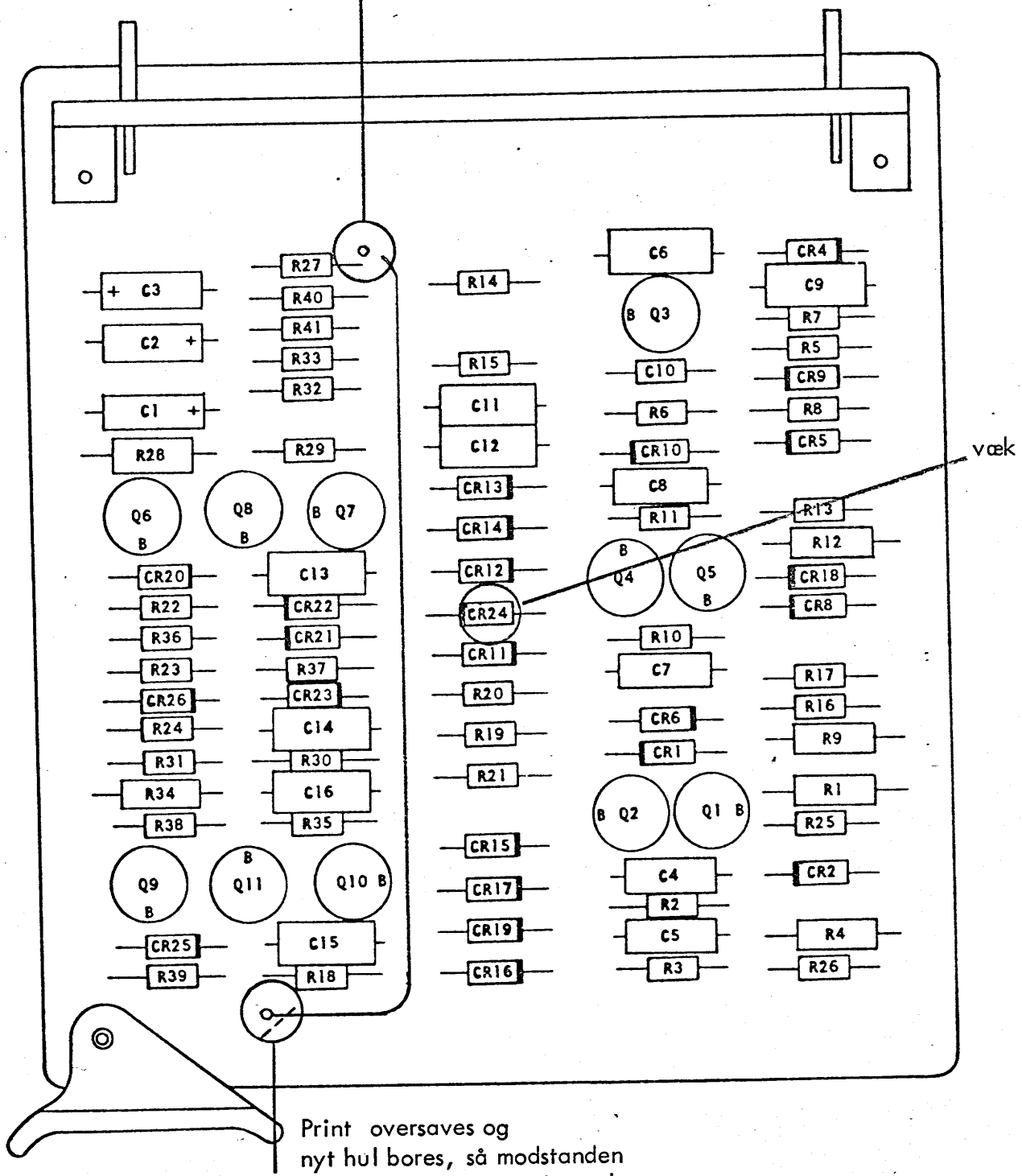
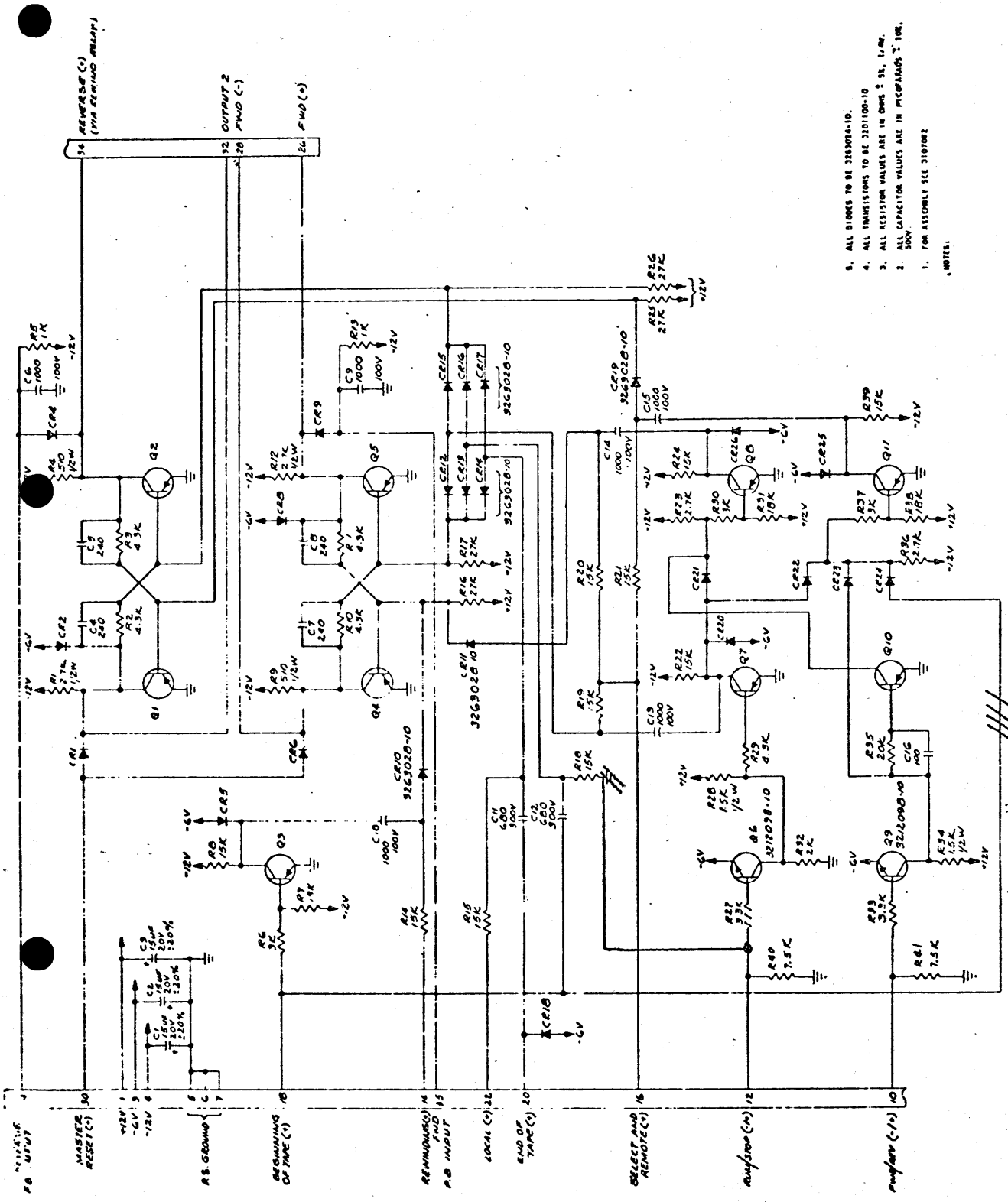

Figure 6-7.  
Forward/Reverse Logic Circuit Board, Assembly Drawing  
(3107082-10)

Fig. 2



- 1. ALL DIMES TO BE 3107084-10.
- 2. ALL TRANSISTORS TO BE 3107100-10
- 3. ALL RESISTOR VALUES ARE IN OHMS UNLESS OTHERWISE SPECIFIED.
- 4. ALL CAPACITOR VALUES ARE IN MICROFARADS UNLESS OTHERWISE SPECIFIED.
- 5. FOR ASSEMBLY SEE 3107082-10.

AFbrydes

Figure 6-6.  
Forward/Reverse Logic, Schematic Diagram  
(3107083)

Fig. 3

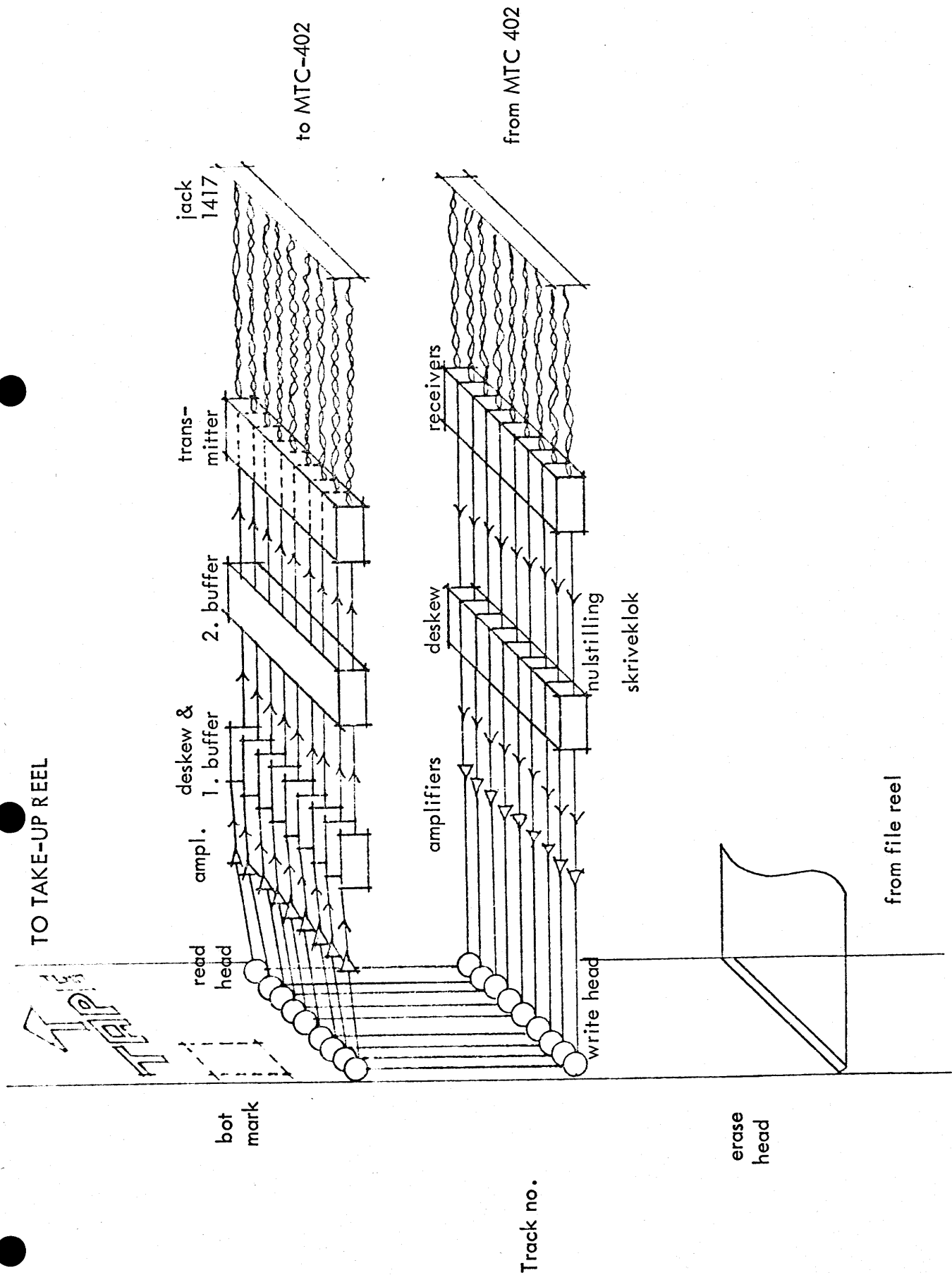
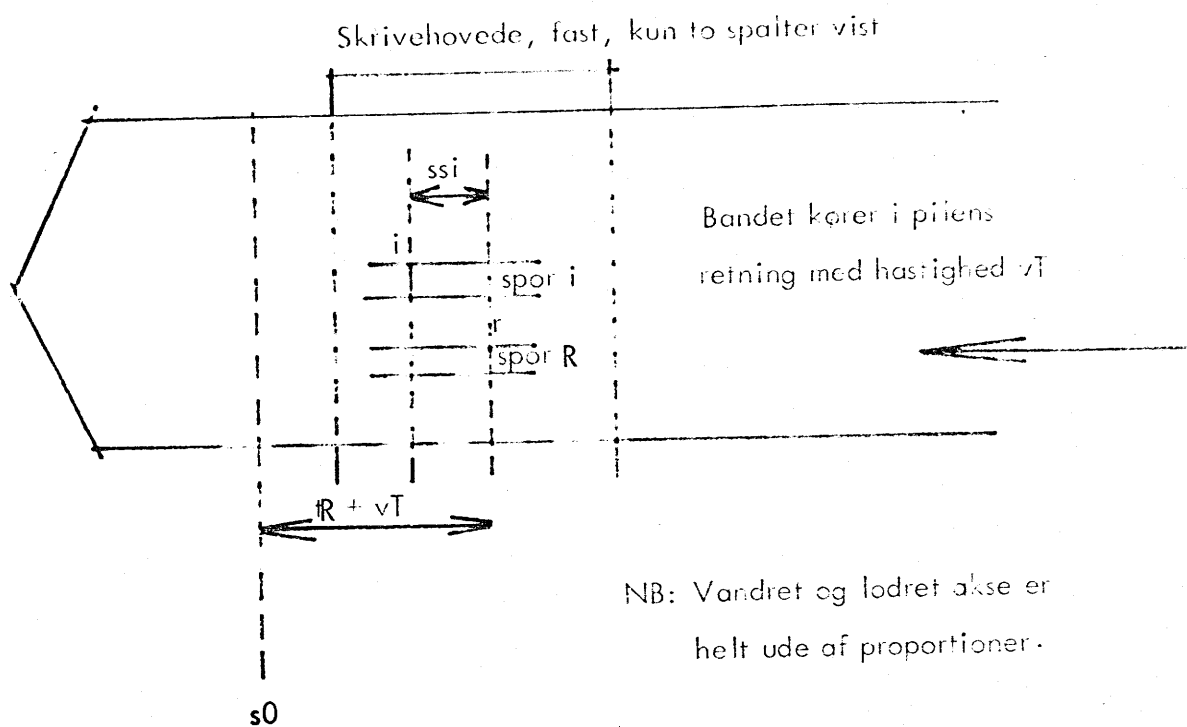

FIG. 4



$s_0$ : Referencenormal. Til tiden  $t_0$  går  $s_0$  gennem referencespalten R

$t_R$ : Forsinkelse af skrivning i referencespor.

$t_i$ : Forsinkelse af skrivning i spor i,

$ssi$ : Afstand fra referencespalte i spalte i,

$s_i$ : Afstand fra referencenormal  $s_0$  til skrevet bit.

Formål:  $s_1 = s_2 = \dots s_9$ , ( Alle bits på række ).

$s_i = t_i \times vT - ssi$ ,  $s_R = t_R \times vT$ , medfører

$t_i = rT + ssi/vT$

Fig. 5. Uledning af 'deskew' forsinkelse ved skrivning.

FIG. 5



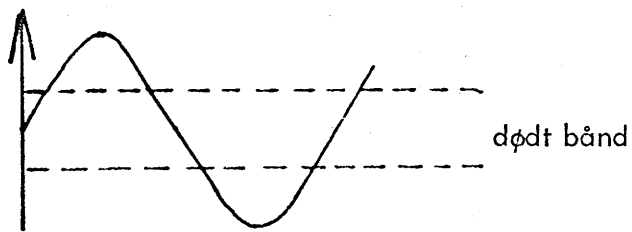

Forstærker udgang



Klipper og ensretter

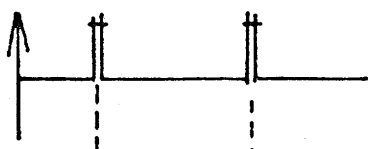

Detekteret

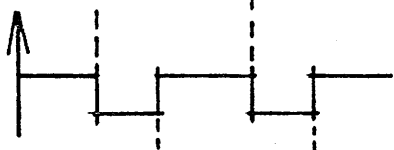

Efter Deskew

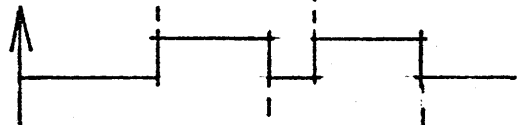

Opsamlingsregister

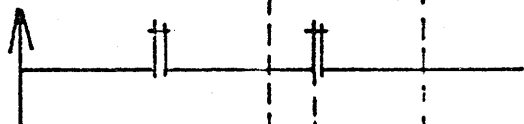

Or-impuls

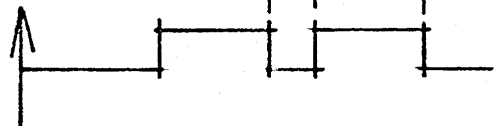

Opsamlingstid

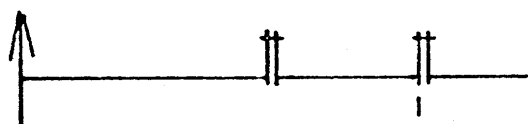

Transfer-impuls

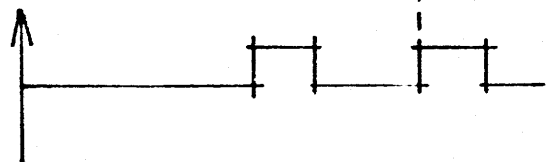

Read-Strobe

FIG. 6. Karakteristiske tidsforløb

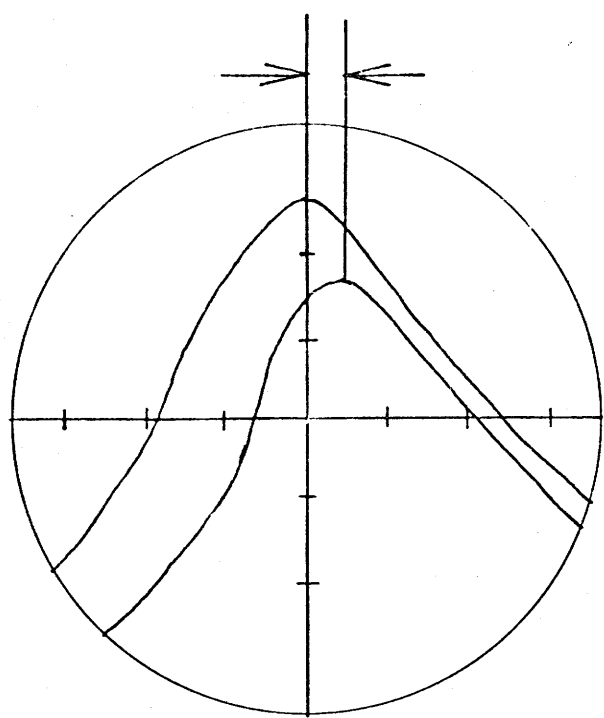

Vandret:

Lodret: 0,5 V/cm

De to kurver viser signaler på udgangen af læseforstærkere i pos. 1 og 7.

Fig. 7. Måling af "skew" mellem yderspor på TM-7

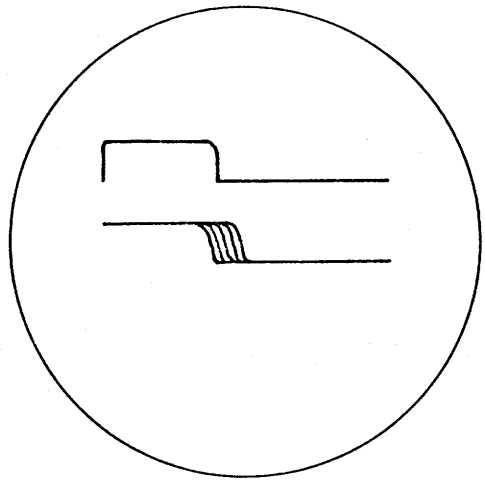

Vandret:

Lodret: 2 V/cm

Øvre stråle: Sidst ankomne bits "deskew" forsinkelse. ( trigger)

a) Nedre stråle: "deskew"-forsinkelse for bit under justering.

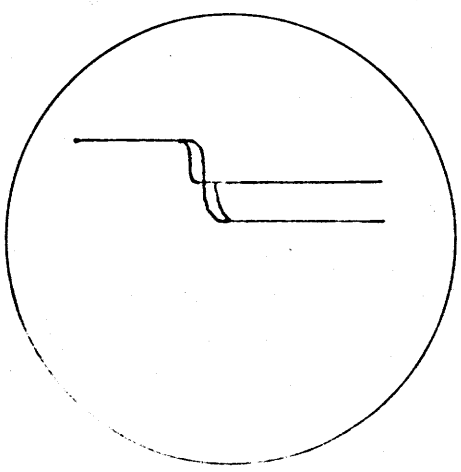

Samme signaler som på a) men adderet til kontrol af puls-parring.

b) Fig. 8.

TECHNICAL NOTE.

POLARITY  
on  
MAGNETIC TAPE UNITS

A/S REGNECENTRALEN

RCSL 44-RT 33

Editor: O. Steenberg

Nov. 1968

Table of contents:

1. 1.	Scope	page 1
2. 1.	Standards	page 2
3. 1.	Measurement of polarity on erase-head	page 3
3. 2.	Measurement of polarity on write-heads	page 4
4. 1.	Determination of polarity for erase- and writeheads in the same measurement	page 6

## 1.1 Scope

This Note describes 2 methods of measuring the polarity of write- and erasehead on magnetic tape-units.

The measurements demand 2 instruments

1. Magnetic Compass
2. Magnetic Tape Viewer

The measurement gives the answer to the following questions:

- A. Polarity of erase-head
- B. Polarity of all write-heads

### Notice:

After polarity-check of all tape-units, the problem of changing polarity may perhaps be important.

In general three rules must be fulfilled.

1. Equal polarity of erase- and writeheads.
2. All tape-units connected to a computer and off-line equipments with equal polarity.
3. Two or more computer-systems working together with equal polarity.

2.1 Standards

All known international standards handle the problem in this way:

ECMA Standard writes:

"The tape shall be magnetized so that the beginning of tape is a North seeking Pole".

This means that the erase-head must erase the magnetic tape in such a way that the rim end with the BOT tab is a Magnetic North Pole.

The same must be fulfilled, when all write-heads are kept Reset.

Now Rule 1:

The BOT tab end is a Magnetic North Pole  
and following Rule 1:

ECMA Standard	ECMA/TC1/66/37 part 2.14
American Standard	800 bit/inch, NRZ 1, part 5.4.1
British Standard	PS 4.8.51 part 3.16

and manufacturers following Rule 1:

IBM 2400 series

CDC

REGNECENTRALEN (AMPEX TM-7)

3.1 Measurement of polarity on erase-head.  
A/S REGNECENTRALEN TM-7, 7 and 9 tracks.

Load tape-unit with normal tape (with BOT and EOT tabs).

In "LOCAL" mode and the test switch in "W" position drive "FORWARD"  
in app. 60 sec.

Switch to "REVERSE" drive and wait for the BOT tab.

Now the first part of the tape is erased.

Unload the tape, and cut out a piece of tape just after the BOT tab.

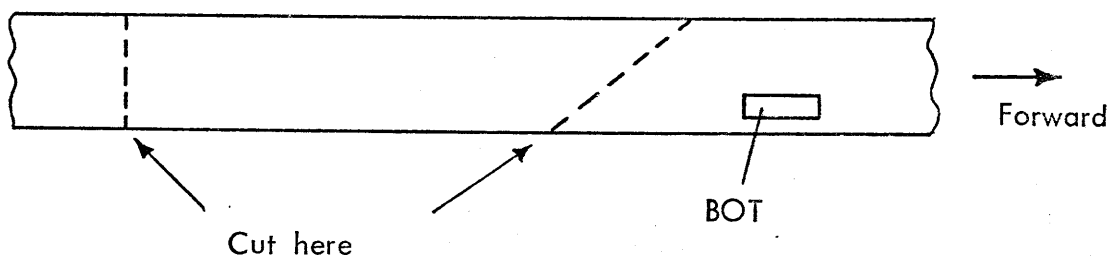

Test this piece of tape with a compass.

Carefully bring near the point of tape to the north-seeking pole of the  
compass needle, and observe the movement of the compass needle.

If the needle is repelled, the tape point is magnetized as a magnetic  
north pole.

Otherwise if the needle is brought near to the tape point, the tape  
point is a magnetic south pole.

3.2 Measurement of polarity on write-heads  
A/S REGNECENTRALEN TM-7, 7 and 9 tracks.

After checking the erase-head, load the tape-unit with normal tape.  
Erase the tape as explained on page 3.1.

Now all write amplifiers must have DC Reset in this way:

7 tracks:

The input to the  $\mu$ L 900 put to ground in pos. 20 (use card extender).

9 tracks:

The input to the  $\mu$ L 900 put to ground in pos. 21 (use card extender).

At the same time the testgenerator is inhibited.

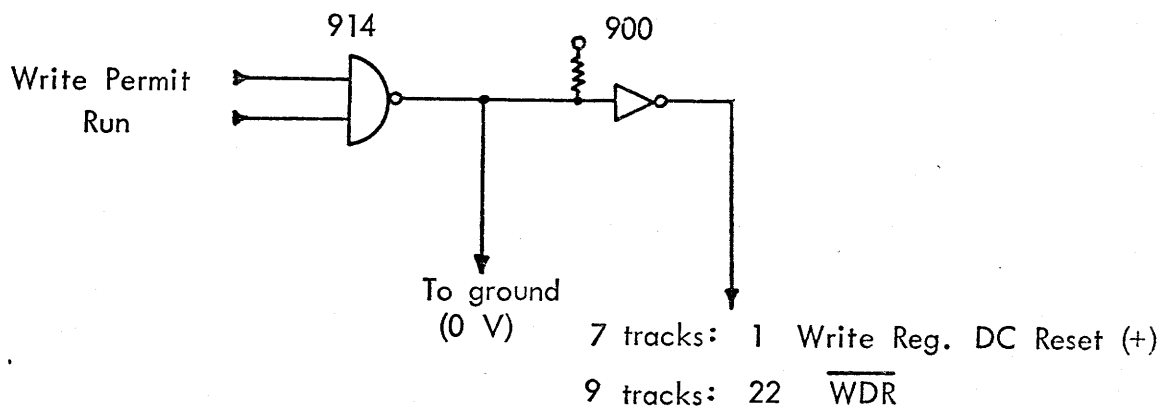

Being at the BOT tab, and in "LOCAL" mode drive "FORWARD", and by means of the testswitch write "manual blocks" by shifting from "N" to "W" position and back.

After writing 4-5 blocks, put the testswitch in "N" position, and unload the tape.

With oxide side up examine "block" 2 or 3.



If all write-heads are of the same polarity as the erase-head, you get the picture shown in fig. 1. (Only 3 tracks shown).

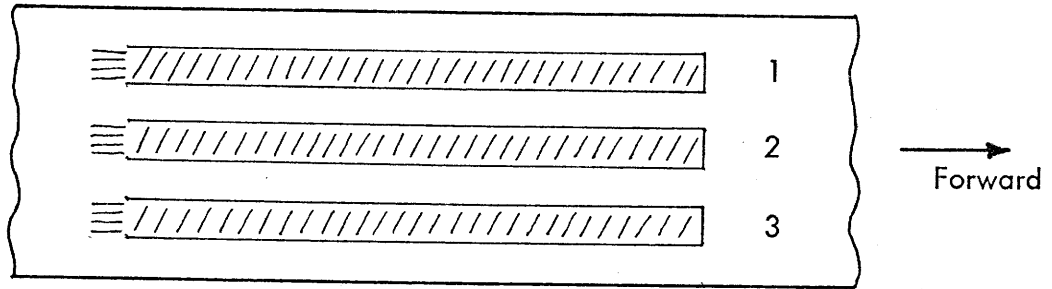

Fig. 1 Writeheads correct.

If one writehead is opposite, you get the picture shown in fig. 2, where track 2 is wrong.

If all writeheads are opposite, you get the same picture in all tracks

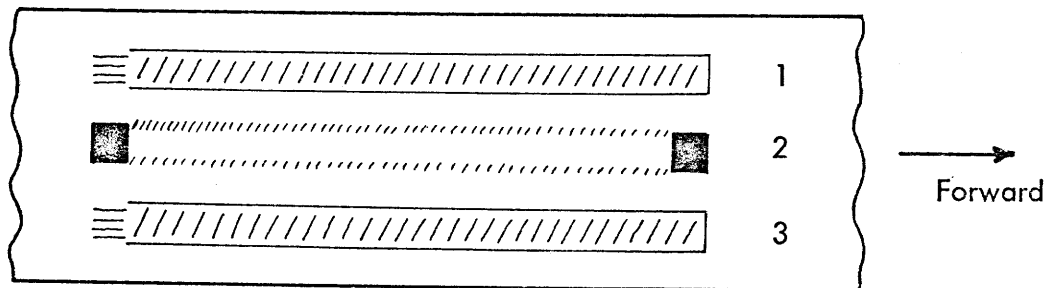

Fig. 2 Writehead two opposite.

In fig. 3 the track sequence is shown

Oxide-side up.

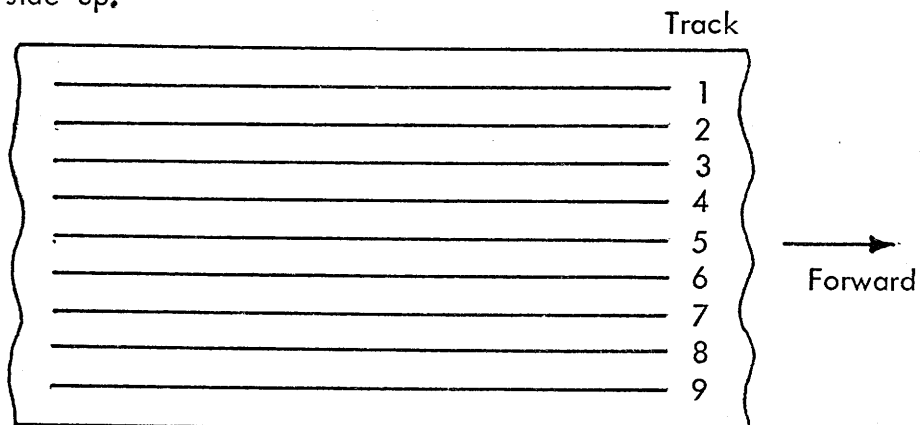

Fig. 3 Track sequence

4.1 Determination of polarity for erase- and writeheads in the same measurement.

A/S REGNECENTRALEN TM-7, 7 and 9 tracks.

To the measurement use erased tape, erased on a well-known tape-unit (checked after 3.1).

Load this test-tape on the tape-unit under test, reset all write amplifiers as in 3.2 and make "manual blocks" as in 3.2.

Unload the test-tape (testswitch in "N" position) and examine the tape with the tape viewer.

If write- and eraseheads are equal to the testtape, you get fig. 1.

Is one of the writeheads opposite, you get fig. 2. (See text to fig. 2).

Opposite erase-head gives fig. 4

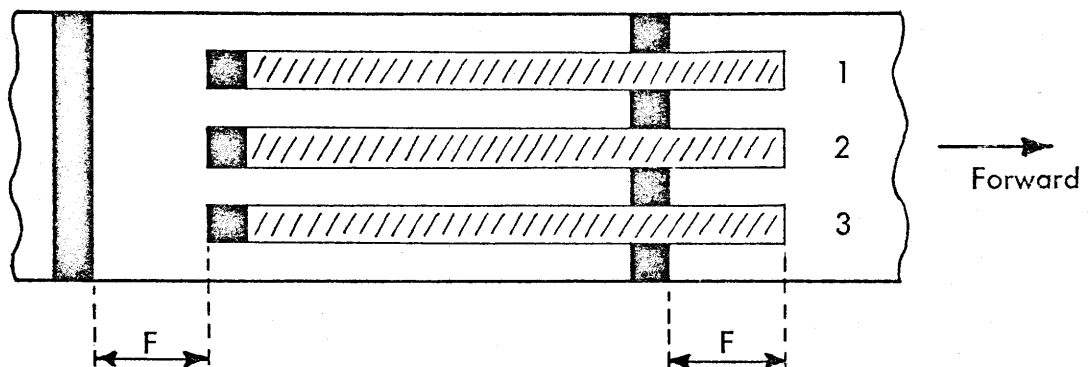

F: Physical distance between write- and erasehead.

Fig. 4 Erasehead opposite.

and both erase- and writeheads opposite fig. 5.

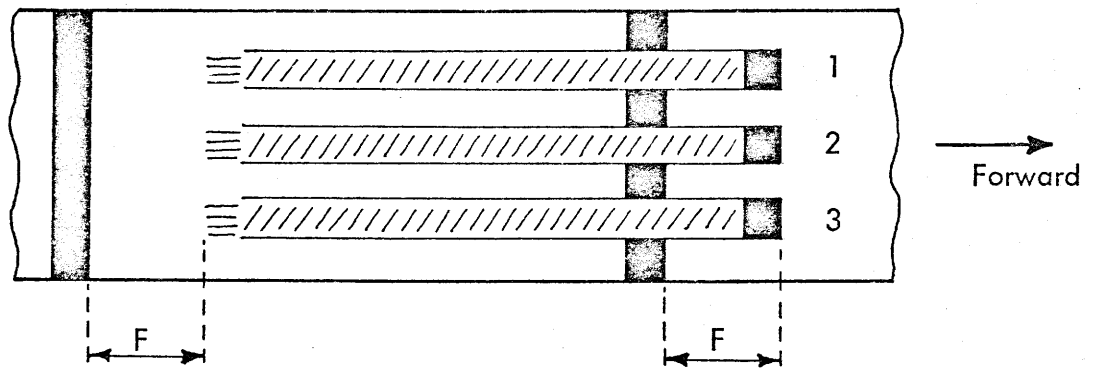

Fig. 5 Write- and erasehead opposite.

RCSL : 44-RT 291  
pp. 18  
Author : FH  
Edited : May 1970

THE HANDLING AND  
STORAGE OF COMPUTER TAPE

---

A/S REGNECENTRALEN

1, Falkoneralle

2000 Copenhagen F.

## THE HANDLING AND STORAGE OF COMPUTER TAPE.

As increasing quantities of the world's business records are being kept not in books and file drawers, but on magnetic computer tape, there is a growing concern about the permanence and recoverability of these vital facts that are invisibly stored on a plastic ribbon.

The preservation of both operating and historical files is the primary concern. But another factor of real importance is the prevention of damage to the recording tape not just so the information will be safeguarded, but so that the maximum use may be obtained from every reel of tape. Both of these factors are economic in nature. If stored information is uncoverable because of either lack of safeguards by operating personnel or major catastrophe during storage, the result could be anything from temporary inconvenience to complete business collapse. If reels of tape are failing and being retired long before their normal life expectancy, operating expense is increased. Of course, this too is undesirable.

This paper will discuss in depth, the considerations and practices of greatest importance to the computer user. If every one of the many suggestions were followed completely, an ideal situation would exist. Since many facilities can function adequately with less than the ideal, you may wish to adopt only a portion of our recommendations. Some of the precautions may be considered too time-consuming, or too costly for a given application. In short, we can say that the overall reliability of computer operation is directly proportional to the care that is exercised in the two important topic areas: HANDLING AND STORAGE.

### THE BASIC FACTS.

Modern magnetic tape coatings have the ability to retain the intelligence placed on them during the recording process for an infinite amount of time. The recorded information does not tend to fade or weaken with age. It is essential permanent and will remain unchanged until actually altered by an external magnetic field. This erasing of the tape may be done intentionally, so that the tape can be used for another recording or accidentally, by operator error or poor storage procedures. Later in this paper the matter of accidental erasure will be more fully discussed.

Even though the magnetic signal will not deteriorate the physical properties of the recording medium are susceptible to damage. It can be said, far and away, the reports of problems encountered with computertape performance are predominantly physical in nature. Since this is the case, we must be concerned with preserving the tape in a form that will make it physically possible to recover the recorded information when needed. Poor handling habits or faulty storage procedures can render a tape useless because of physical damage. A great deal can be said about the physical preservation of computer tape and to make the information more meaningful, each of several topics will be treated separately.

## THE WORK AREA.

The location in which the tape is actually used should approach, as closely as is practicable, a "clean - room" environment. By definition then, this area is characterized by absence of normally expected airborne dust and lint. Various air-conditioning filtration systems are available to accomplish this cleaning.

Whenever possible, maintain the room air pressure at a somewhat higher level than the surrounding area. This positive internal pressure will prevent dust infiltration through doors and windows that are not absolutely air tight and, of course, is most important in preventing dust from entering when a door is opened. To additionally insure against dust contamination, lint - free smocks are worn by personnel associated with the manufacturing and testing of computer tape.

The design of the computer area should be such that reasonable control of temperature and relative humidity can be exercised. Variations of temperature should be held to within  $\pm 4^{\circ}\text{C}$ , of a preselected value and the relative humidity should be kept constant to within  $\pm 10\%$ . Our general recommendation would be an environment that is comfortable for the operating personnel, as this is also ideal for the tape. In broad terms this would be a temperature in the 20's and a relative humidity of about 40%.

The following are a few rules of thumb:

The first, there should be no smoking in a clean room. The smoke will not necessarily contaminate the tape, but the ashes can.

The second rule of thumb, is no eating or drinking in the clean room. Food can be transmitted to the tape from the operators hands and a spilled drink will contaminate the room as well as the tape.

Another rule of thumb, is to keep all fiber-producing material, such as paper or cardboard, out of the clean room. Card punches are notorious for producing fibers. Also, lint producing clothing should not be worn in the clean room. Lint fibers, as well as paper fibers, will be attracted to the tape due to the normal static charge that can build up on a roll of tape in use.

Recognizing the fact that printers, cards readers, and card punching equipment are all part of a computer system and are generally located in the vicinity of the tape drivers, a word of caution is in order.

To reduce paper dust and fiber lint contamination, the equipment that uses paper should be located in the area of lowest pressure. This will insure that any contamination generated by the paper handling will move in a direction away from the tape and tape-transporters thus reducing the possibility of contamination.

Last, but not least, is the maintenance of the clean room.

The integrity of the computer area should be maintained by periodic cleaning of shelves and floors. There is a special liquid cleaner now available for this purpose that leave no residue. The floors should not be waxed because normal foot traffic abrades the wax, causing fine dust that could contaminate the entire room. When vacuum equipment is used for cleaning, the exhaust from this unit must be located outside the room.

Aside from the direct benefits gained from a well maintained, clean, temperature and humidity controlled environment, the psychological effect upon the employees is of great importance. It is found that operators exercise more care and are more concerned with quality when working in an environment such as just described.

## HANDLING THE TAPE.

The cannister in which the tape is stored is probably the cleanest area in the computer center, and of course, this is the reason that tapes should remain in the cannister until actually placed on the tape drive and be returned to the container immediately after use. To maintain the cleanliness of the cannister, the cover should be replaced when the tape has been removed for use. The cannister should not be opened outside of the clean room environment.

The hub is the strongest and most stable part of the reel. This fact is the reason why operators should always handle the reel by the hub and not the flanges. The operator should never squeeze the reel flanges together when picking up a roll of tape or when handling it. This also applies to mounting the reel on the transport. Pressure should only be applied to the hub area of the reel and not the flanges. If the reel flanges are forced against the edges of the tape the edges can be damaged, particularly if the roll has a scattered wind.

It has been said that careless handling and poorly adjusted tape drivers are the two predominant reasons why computer tapes fail prematurely. If strict attention is paid to these two areas, immediate benefits will be noted in increased tape life; and the threat of information loss will be substantially reduced.

When handling tapes, operators should use utmost caution to insure that the tape does not become contaminated by fingerprints. Simply stated, fingerprints are nothing more than deposits of body oils and salts. These oils will not attack the oxide-binder system, but will form excellent "holding-areas" for dust and lint.

Fingerprints on the backing are just as serious as on the coating because dirt deposits will transfer from the backing of one wrap to the coating of the next wrap on the reel. When a reel that has been contaminated in this manner is put into use, the tape drive itself can be affected and will spread this contamination to other clean reels of tape that are used after the dirty reel.

This is one of the reasons why this is important to visually inspect the tape handler after each roll of tape is run to determine if cleaning is necessary. If the transport becomes contaminated with dust or wear products from the tape, complete contamination of an entire roll of tape can easily be the result. Contaminants can collect on heads and guides and be dumped along the backing or coating surface of the tape. This contamination will then be wound into the reel under pressure causing it to adhere firmly to the surface. Each one of these deposits will appear as a dropout or group of dropouts the next time the tape is used.

Tape contamination caused by fingerprints can be reduced by remembering not to touch the tape unnecessarily.

Frequent cleaning of the tape drive will reduce the chance of spreading contamination from one reel of tape to others in the library. When liquid cleaner is used, it should be given time to thoroughly dry before loading the tape. This will prevent damage to the tape should the cleaner have any tendency to attack the magnetic tape.

Accumulation of tape wear products on the transport can be largely eliminated by using a high reliability tape.

Empty reels should be thoroughly inspected and cleaned before winding tape on them for storage. Reels with hub damage, such as plastic burr, or with dirty hubs can cause tape distortion exactly as outlined in the paragraph above. Maintaining reel integrity cannot be over emphasized as valuable information can be lost not because of tape failure, but because the tape was distorted by a dirty reel.

If a reel of tape that has been subjected to extremely low temperature is put into use before it is given the time to return to normal environmental conditions, it may become physically distorted when used. When the roll is subjected to the start-stop action in use, the individual tape layers can shift due to momentum and result in severe "cinching". This can also happen if a carton containing very cold tape is dropped or handled roughly. We emphasize our recommendation that incoming tape be allowed to stabilize for 24 hours before being put into use. We do not recommend using artificial means to hasten this stabilization period.

#### Edge damage:

One of the most common and more serious forms of tape failure is generally categorized as edge damage. Damaged edges can be caused by the reel, tape drive or the operator. A broken or badly distorted reel can quickly damage a tape. The effect of a broken or cracked flange is easily noticed as the tape will exhibit a series of nicks or mutilated areas along one edge; and the cause can easily be detected because of the obvious defect in the reel. A warped or distorted reel, however, can also cause damage to one or both edges when the tape is allowed to rub against the flange when being used.

A similar type of edge damage will also occur if the transport is misaligned.

Either of these faults can result in complete failure of a roll of tape. Not only will the edge track be lost, but the debris generated from the edge damage can be redeposited back into the surface of the tape across the entire width. An examination of the edges of a tape that has been damaged in this manner would disclose an accumulation of loose polyester fibers and loose oxide.

While this type of edge damage is serious, it is sometimes difficult to ascertain its cause or even to notice the effect until the damage is severe. We suggest that operators acquire the habit of physically inspecting the transport in the area of the guides and heads for an excessive buildup of oxide or backing debris. This is generally the first clue that something is wrong. Excessive errors on an edge track may also indicate that an alignment problem exists.

It is also good practice to observe the physical condition of the tape. A sure sign of developing edge damage would be a lip or distortion on the edge being injured. When wound on the reel, the effect of this lip will be cumulative and can stretch the backing. The stretched backing will be rippled and will not conform to the record or read heads the next time the reel is used.

If a reel in this condition is rewound immediately before being put into storage, it may be possible to salvage the roll. If this is not done, the backing will be permanently stretched and will not recover. This will result in the entire roll having to be discarded. We strongly recommend that operators be constantly on the alert for signs of potential trouble. This can best be accomplished by understanding what to look for, and by making continuing inspections of both tape and handler a habit.

#### WHEN TAPES ARE SHIPPED.

As dataprocessing centers are expanded and added at different geographical locations, it is sometimes necessary to send recorded tapes from one installation to another. There are



certain precautions that apply to the shipment of computer tapes that should be followed to insure safety in transit.

Logically, the first consideration would be the physical protection of the tape while being transported. The outer shipping container into which the cannisters are placed must afford the necessary strength and rigidity to protect the tape or tapes from damage caused by dropping or crushing. While a container that is 100% water-tight would not be necessary, it must nevertheless, provide a reasonable degree of water resistance. It should, for example, be capable of protecting the contents from being damaged if, during shipping, it is left on a loading dock in the rain.

While it is good practice to always secure the free end of a reel of tape, it is particularly important when preparing reels for shipping. While in storage, either a hold down sponge or a vinyl strip may be used, then during shipping, it is advisable to use both of these devices. We recommend this because there is some tendency for the vinyl strip to pull loose when subjected to very cold conditions. The hold down sponge, if used alone, could be jarred loose if the shipment were handled roughly; but the combination of the strip and the sponge seems to function ideally.

While the purely physical shipping precautions are not unique to magnetic tape, but are considered good practice in preparing any item of value for transport, there is another consideration that is of prime importance. Since the tape is a carrier of magnetic information, measures must be taken to protect the reels from accidental erasure.

It is found that field strengths within the tape of 50 Oersted or less causes no discernable erasure.

The average bulk degausser, purposely designed to produce a maximum external field that is used to erase tape while still on the reel, produces a field of 1500 Oersted. Sources of magnetic energy to which tape being shipped might be subjected, would be motors, generators, transformers etc. These devices are designed to contain their magnetic fields to accomplish some type of work. With this in mind, we feel it is safe to assume that field strengths of more than 1500 Oersted would not be encountered in ordinary shipping situation.

Because field intensity decreases rapidly with distance from the source, the 50 Oersted point (mentioned earlier as not affecting the tape) is reached at a distance of 6 - 7 cm. from a 1500 Oersted source. From this it can be seen that the easiest and least costly method of obtaining erasure protection is by insuring a degree of physical spacing from the magnetic source.

We suggest that tape being prepared for shipment be packed with bulk spacing material such as wood or cardboard between the cannister and the outer shipping container. Based on the paragraphs above, we feel that 6 - 7 cm. of bulk spacing would give adequate protection, and virtually eliminate any potential erasure. This magnetically protective spacing can also be justified because of the excellent protection gained against physical damage to the contents.

Tape in transit may be subjected to temperature extremes. Temperature as low as -20 C might be encountered in the cargo hold of high flying aircraft. A temperature of 50 C could easily be encountered in a motor vehicle in the summer sun. It must again be emphasized that all incoming tape should be allowed to reach environmental equilibrium before being used.

## THE STORAGE AREA.

The temperature and humidity of the storage area should closely approach that of the work area. The smaller the environmental change experienced by the tape, the better will be its operation and reliability. As a general rule, we recommend a temperature between 15 and 25°C, and a relative humidity between 40% and 60%. Protection from accidental erasure while in the storage area is easily accomplished and is, ironically, of little concern. There are two reasons why this is true. First of all, fields strong enough to cause erasure are just not normally found in an office atmosphere.

Secondly, as mentioned earlier, if the tape is kept as little as 6 - 7 cm. away from even a strong magnetic source, this spacing should be sufficient to offer adequate protection.

The hub is the strongest part of the reel. Not only should the reels always be handled by the hub, but in storage, they should be supported by their hubs. This is one of the two basic reasons why the reel should be returned to its cannister before being placed into storage. The cannister is designed so that the reel actually hangs by the hub with no weight on the flanges. The other reason for using the cannister is obviously protection of the reel from dust.

The closed containers should be placed into storage on edge, so that the reel is in an upright position. While they may also be stored individually, lying flat., the cannisters should never be stacked so high that there is a possibility of crushing or distorting the bottom container from the excessive weight of the stack, as this could cause edge damage to the reel of tape in the cannister. For long term storage, additional protection from dust and moisture can be gained by sealing the cannister in a plastic bag. It is generally considered good practice to clean the cannister before bringing it into the computerroom so that dust, that has accumulated during storage, will not be transported to and contaminate the clean room.

The care exercised in preparing tapes for storage is every bit as important as the excellence of the storage area. Of prime importance is the way the tape is wound on the reel, as poor winding can result in distortion of the tapes backing.

We recommend a wind tension that is relative low. 175 - 225 gram per 1/2 inch of tape width is sufficient to render a firm, stable wind. This tension, while great enough, does not result in high pressures within the roll that could permanently distort the polyester backing. Backing distortion, caused by extreme pressures within the tape pack may result if a roll of tape wound too tightly was subjected to an increase in temperature while in storage.

Just as there is a possibility of problems if the tape tension is too great, too low a wind tension can cause difficulty too. If the wind is too loose, slippage can occur between the tape layers on the reel. This "cinching" as it is called, can distort the tape by causing a series of creases or folds in the area that has slipped. When the roll is unwound, the surface will be wrinkled. When an attempt is made to use the tape again, the wrinkles and creases will disrupt the necessary intimate contact between the tape and the head. Because the tape is repeatedly lifted from the head, the result will be a series of continuous errors. If immediately after an occurrence of cinching, the tape is properly rewound, there is a good possibility that the information may be saved.

Along with proper tension, another important consideration is wind "quality". The successive layers of tape should be placed on the reel so that they form a smooth wind with no individual tape strands exposed. A smooth wind offers the advantage of built in edge protection.

A scattered wind will allow individual tape edges to protrude above the others. Since there is no support for these exposed strands, they are vulnerable to damage.

It is sometimes suggested that tapes in storage be rewound at specific intervals such as every 6 to 12 months to relieve internal pressures. This would be recommended for tapes of marginal quality or for those with other than heavy duty binder systems. For a modern day tapes with polyester backings and advanced binders, this periodic rewind might not be necessary.

A good practice, however, is to select a random sample from various areas of the library for visual inspection. The reels chosen can be examined for loose winds and dust accumulations. They should be checked for rippled edges and other signs that indicate the presence of physical distortion. If anything is found that indicates a problem may exist, additional samples should be inspected to ascertain what percentage of the library may be affected.

Some users have purposely placed "control tapes" in storage with the normally used tapes. These controls are periodically inspected both visually and electronically for data errors. Each installation can decide the number of samples or controls necessary to accurately establish the condition of the library. This decision will be predicated on the library size and the importance of the data stored.

Again, we say that if our recommendations as to the storage environment and the actual preparation for storage are followed; no serious problems should be encountered even in long term storage.

## DROPOUTS - THEIR CAUSE AND EFFECT.

Whenever the subject of computer tape is discussed, the characteristic that is often talked about is dropouts. This is because a dropout implies, or actually means a loss of signal that prevents accurate readback of written information. This is serious, because when errors develop after the tape is written, the information may not be recoverable and could necessitate rerunning an entire program.

By definition a dropout is the reduction in readback signal amplitude below some specific level. Also we can say, physically, dropouts fall into three categories, they are:

1. Coated in asperities.
2. Post coating surface contamination or surface disruptions.
3. Usage factors such as improper human handling, improper machine handling and normal tape wear products.

The signal reduction or dropout is an effect caused by the record and/or playback head being spaced away from the nominal surface of the magnetic tape. ( look fig. 1 ). The asperities take two forms. One is the nodule that separates the head from the tape. The other is the hole in the oxide coating which leaves an oxide void or partial oxide void. The surface blemish that causes head to tape separation can be an oxide redeposit that is a normal tape wear product, a piece of lint from environmental contamination, a polyester backing chip, an airborne dust particle, or a coated in particle.

The signal produced from a section of tape of this nature looks like the sketch of the signal envelope seen at fig.1. Note that the signal loss from surface asperities may not always be severe enough to cause a dropout. That is different sized defects cause different degrees of signal loss and the sensitivity of any system to errors can be varied by the site to be more or less sensitive. Some of the blemishes don't cause a 50% loss of signal. Some don't cause a 30% loss of signal.

An example of exactly how a dropout appears on an oscilloscope is shown at fig. 2. This is an 800 bpi signal and you can clearly see the individual bits of information. The total sweep on this fig. represents approximately 1/8" of tape. Each centimeter of the scope scale represents approximately 15 mils of tape length. Note the "tent" appearance or umbrella effect as it's usually termed. This is due to the tape being pulled away from the surface of the head in an area 360° around the nodule or asperity. Pictorially this looks like fig. 2a. Here we see two types of heads. The contoured head is typical of IBM-727, 729 and 2400 series handlers. The flat head at the bottom is typical of the CDC-600 series transports.

We should also note the reduced amplitude to the right of the dropout ( see fig. 2). This is caused by air being trapped around the defect in the area of the umbrella between the tape and head. It requires some small amount of time for the tape to settle back on to the head. This time represents approximately 1/16 " of tape travel. It has little or no effect on the transport operation since the the amplitude reduction is only on the order of 50%.

We are also concerned about noise errors in NRZ ( non-return-to zero ) recording. These are equally as bad as dropouts since the computer cannot distinguish between a noise spike and a normal recorded bit of information. These noise errors almost in all cases come from holes in the tape or non-magnetic particles coated in. These defects cause a change of flux at the head that results in a playback pulse if the tape is d.c. saturated in a given direction ( i.e. record zeros ).  
( look fig. 3 ).

ROTATION

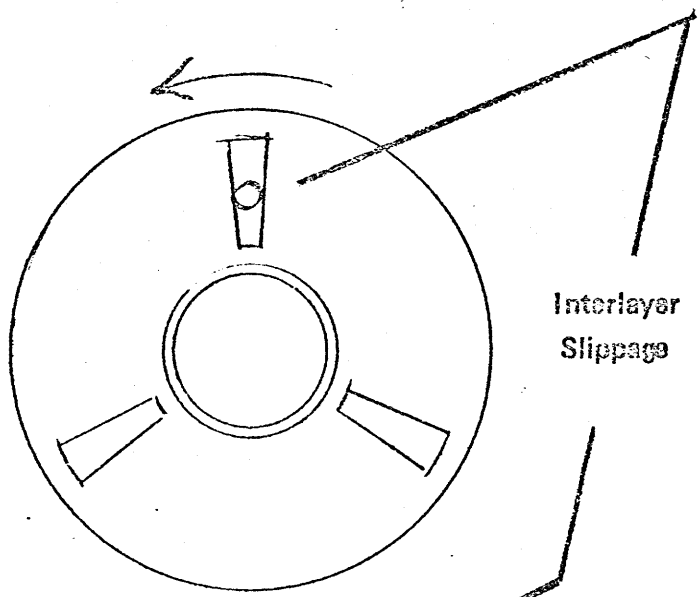

Interlayer  
Slippage

Enlarged View

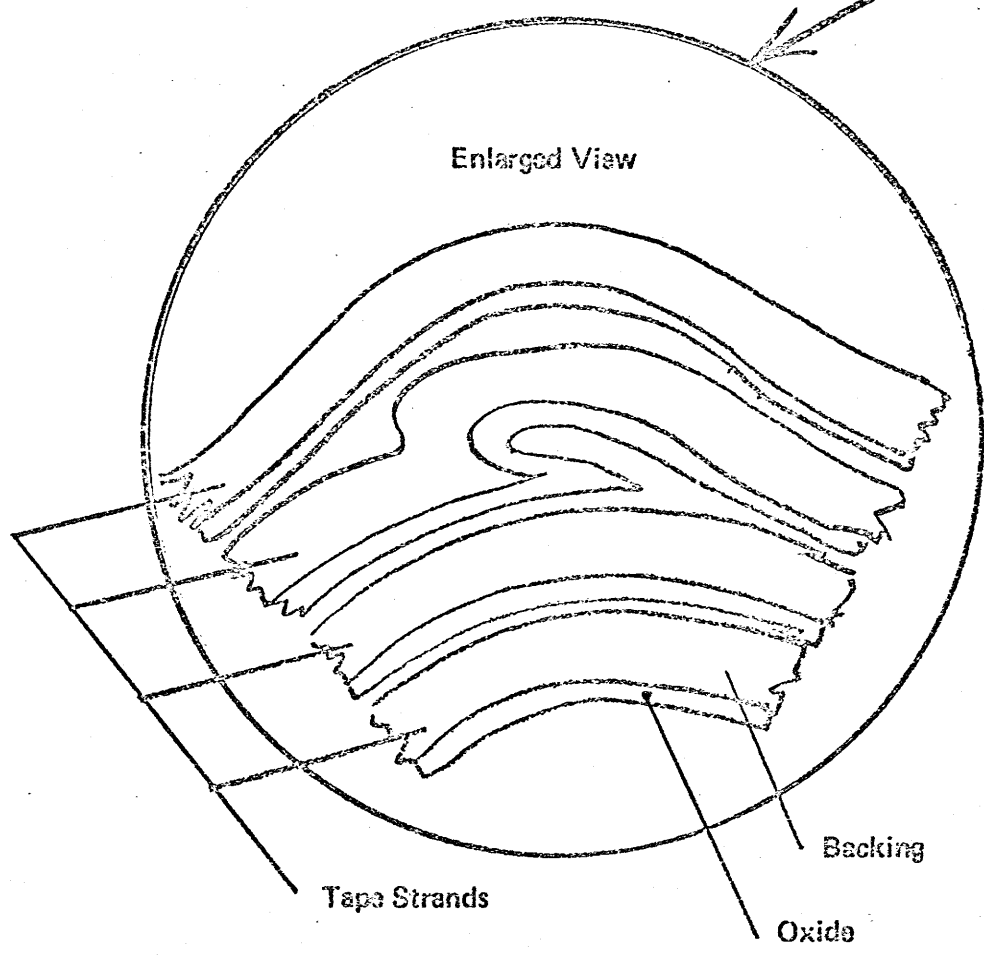

Tape Strands

Backing

Oxide

If the wind is too loose, cinching will develop.

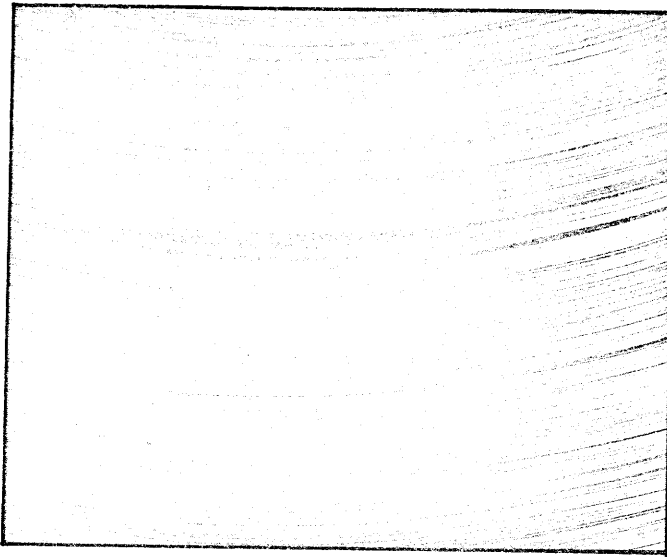

CINCHED TAPE. NOTE THE COMPLETE FOLD OVER OF ONE TAPE STRAND.

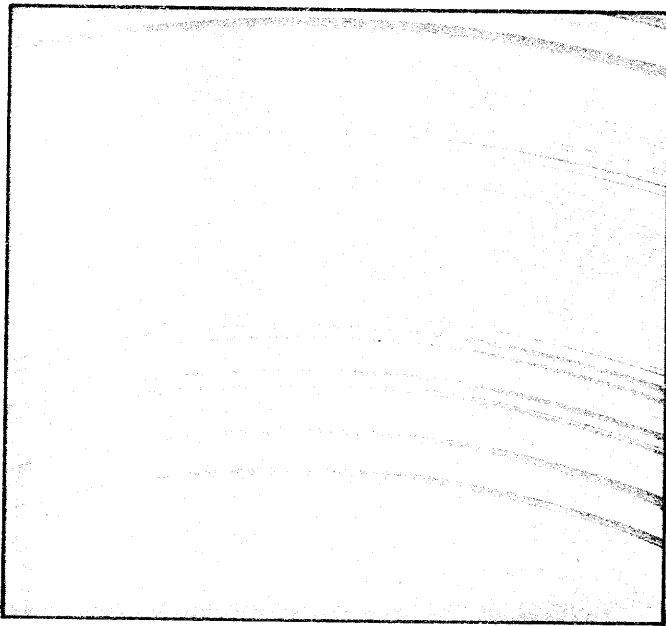

SCATTERED WIND. INDIVIDUAL TAPE STRANDS ARE EXPOSED AND VULNERABLE TO DAMAGE.

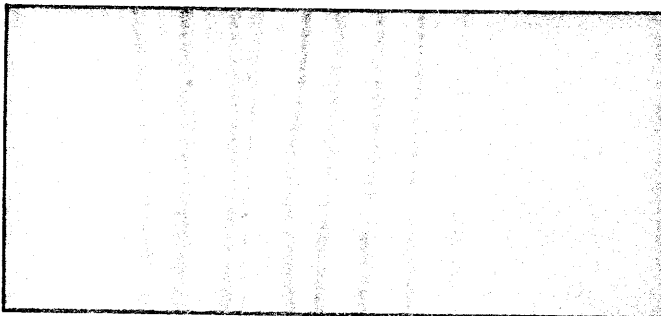

TAPE DAMAGE CAUSED BY CINCHING. THIS 1" LONG STRAND OF 1/2" COMPUTER TAPE CLEARLY SHOWS THE WASHBOARD-LIKE WRINKLES.

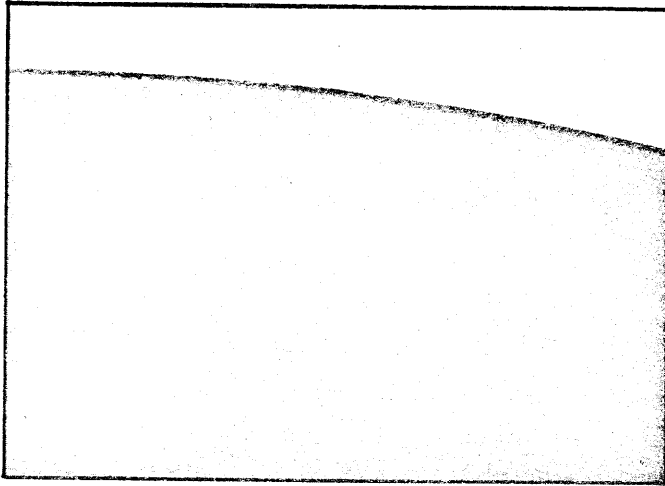

AN ENLARGED VIEW OF DUST CONTAMINATION ON A REEL OF TAPE.

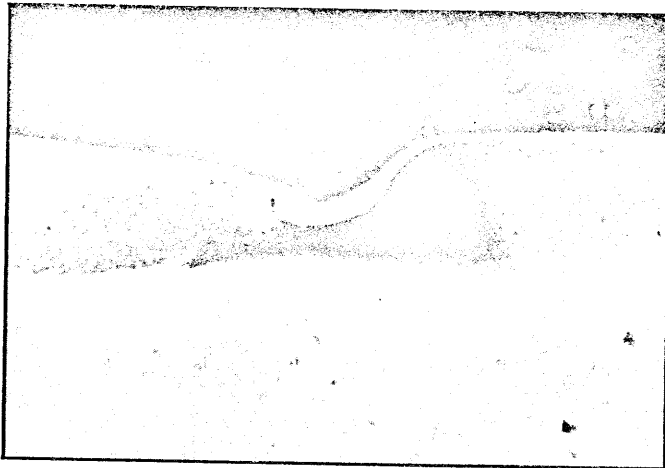

MICROSCOPE VIEW OF A DAMAGED EDGE. AFFECTED AREA EXTENDS ABOUT 15 MILS INTO TAPE.

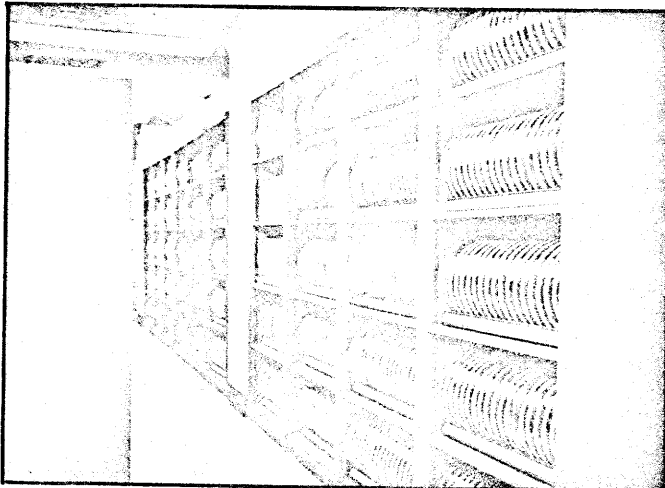

AN EXCELLENT EXAMPLE OF A LIBRARY SHOWING PROPER TAPE STORAGE.





WHEN MOUNTING A REEL ON THE TAPE DRIVE, APPLY PRESSURE TO THE HUB AND NOT THE FLANGES.

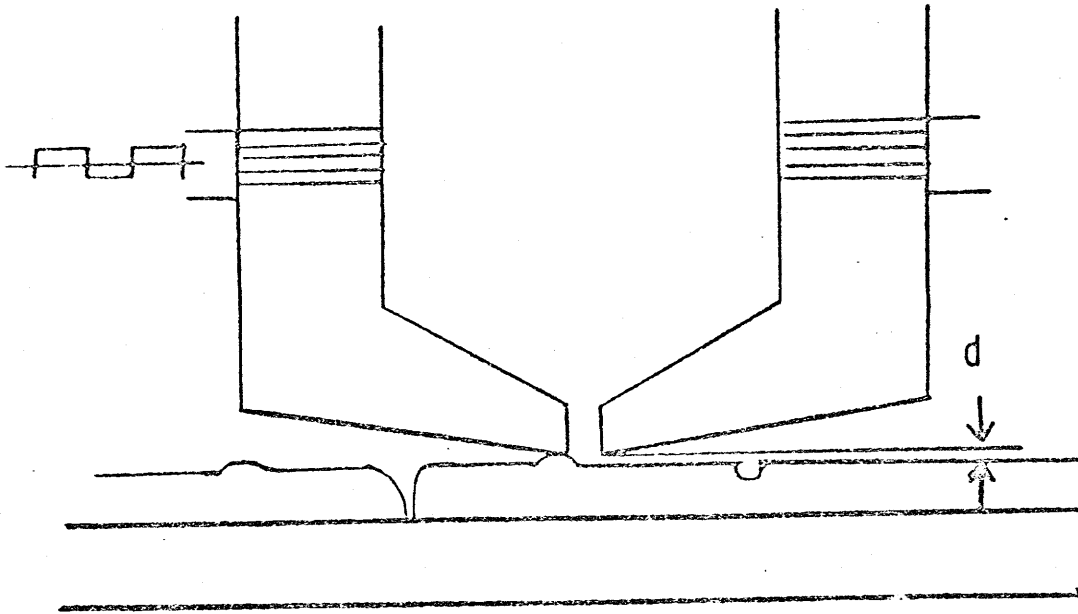

50%

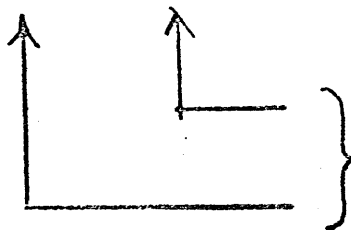
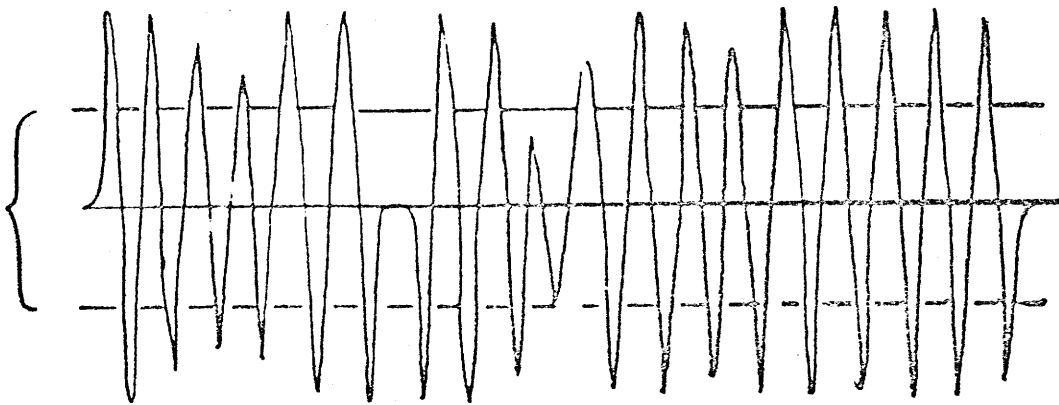

Dropouts

ONES TEST

Fig. 1

Station	Time	Temp	Wind	Dir	Speed	Pressure	Humidity	Clouds	Visibility	Remarks
1	0000	50.0	0			30.00	95	0	10	
1	0100	50.0	0			30.00	95	0	10	
1	0200	50.0	0			30.00	95	0	10	
1	0300	50.0	0			30.00	95	0	10	
1	0400	50.0	0			30.00	95	0	10	
1	0500	50.0	0			30.00	95	0	10	
1	0600	50.0	0			30.00	95	0	10	
1	0700	50.0	0			30.00	95	0	10	
1	0800	50.0	0			30.00	95	0	10	
1	0900	50.0	0			30.00	95	0	10	
1	1000	50.0	0			30.00	95	0	10	
1	1100	50.0	0			30.00	95	0	10	
1	1200	50.0	0			30.00	95	0	10	
1	1300	50.0	0			30.00	95	0	10	
1	1400	50.0	0			30.00	95	0	10	
1	1500	50.0	0			30.00	95	0	10	
1	1600	50.0	0			30.00	95	0	10	
1	1700	50.0	0			30.00	95	0	10	
1	1800	50.0	0			30.00	95	0	10	
1	1900	50.0	0			30.00	95	0	10	
1	2000	50.0	0			30.00	95	0	10	
1	2100	50.0	0			30.00	95	0	10	
1	2200	50.0	0			30.00	95	0	10	
1	2300	50.0	0			30.00	95	0	10	
1	2400	50.0	0			30.00	95	0	10	
1	2500	50.0	0			30.00	95	0	10	
1	2600	50.0	0			30.00	95	0	10	
1	2700	50.0	0			30.00	95	0	10	
1	2800	50.0	0			30.00	95	0	10	
1	2900	50.0	0			30.00	95	0	10	
1	3000	50.0	0			30.00	95	0	10	
1	3100	50.0	0			30.00	95	0	10	
1	3200	50.0	0			30.00	95	0	10	
1	3300	50.0	0			30.00	95	0	10	
1	3400	50.0	0			30.00	95	0	10	
1	3500	50.0	0			30.00	95	0	10	
1	3600	50.0	0			30.00	95	0	10	
1	3700	50.0	0			30.00	95	0	10	
1	3800	50.0	0			30.00	95	0	10	
1	3900	50.0	0			30.00	95	0	10	
1	4000	50.0	0			30.00	95	0	10	
1	4100	50.0	0			30.00	95	0	10	
1	4200	50.0	0			30.00	95	0	10	
1	4300	50.0	0			30.00	95	0	10	
1	4400	50.0	0			30.00	95	0	10	
1	4500	50.0	0			30.00	95	0	10	
1	4600	50.0	0			30.00	95	0	10	
1	4700	50.0	0			30.00	95	0	10	
1	4800	50.0	0			30.00	95	0	10	
1	4900	50.0	0			30.00	95	0	10	
1	5000	50.0	0			30.00	95	0	10	

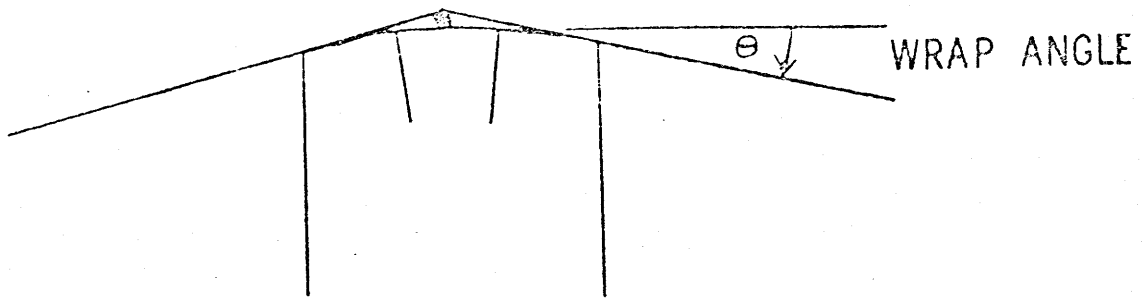

Contoured Head

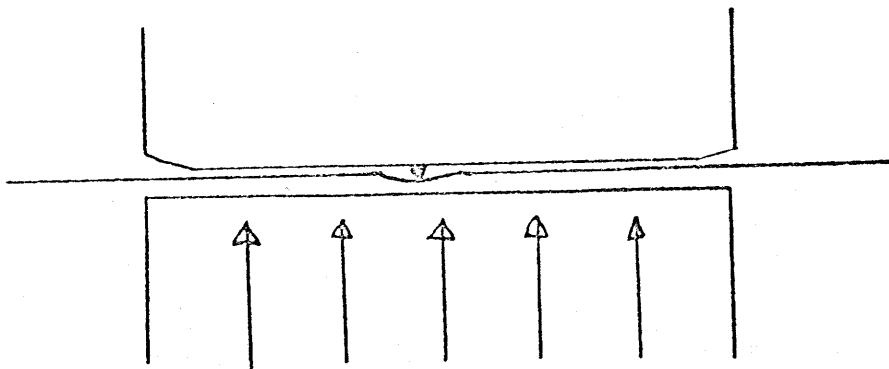

Flat Head

Fig. 2a

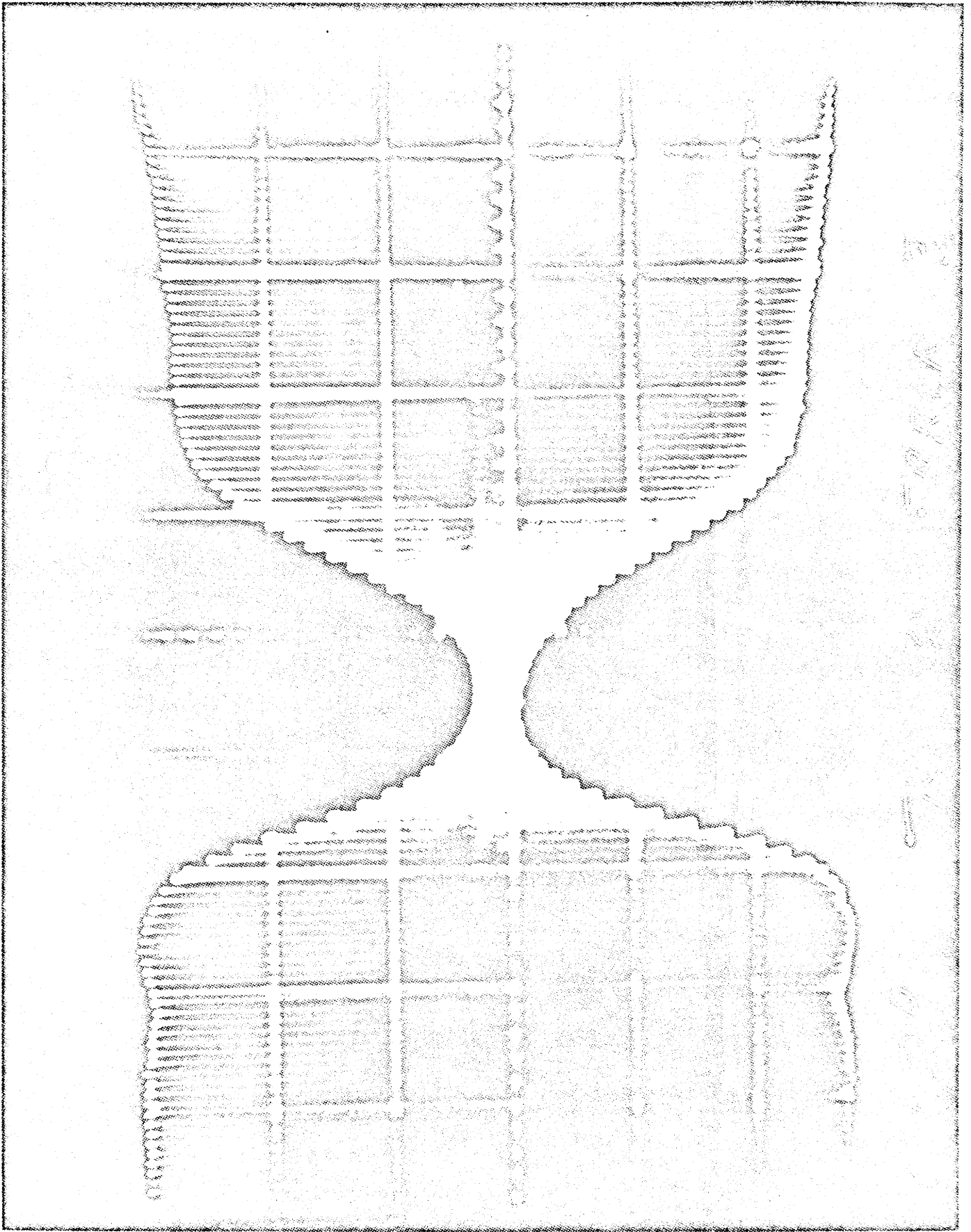
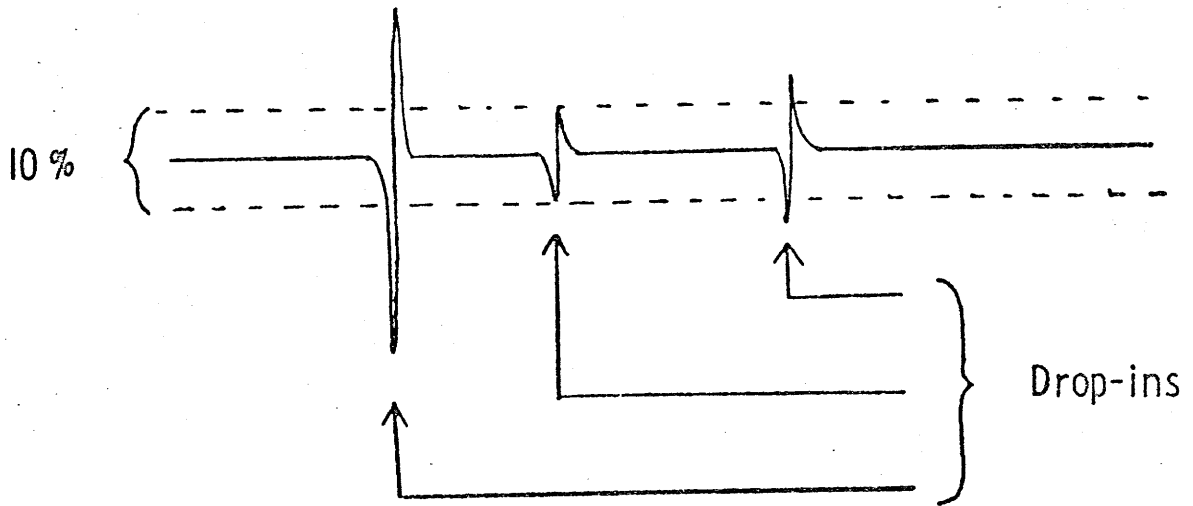
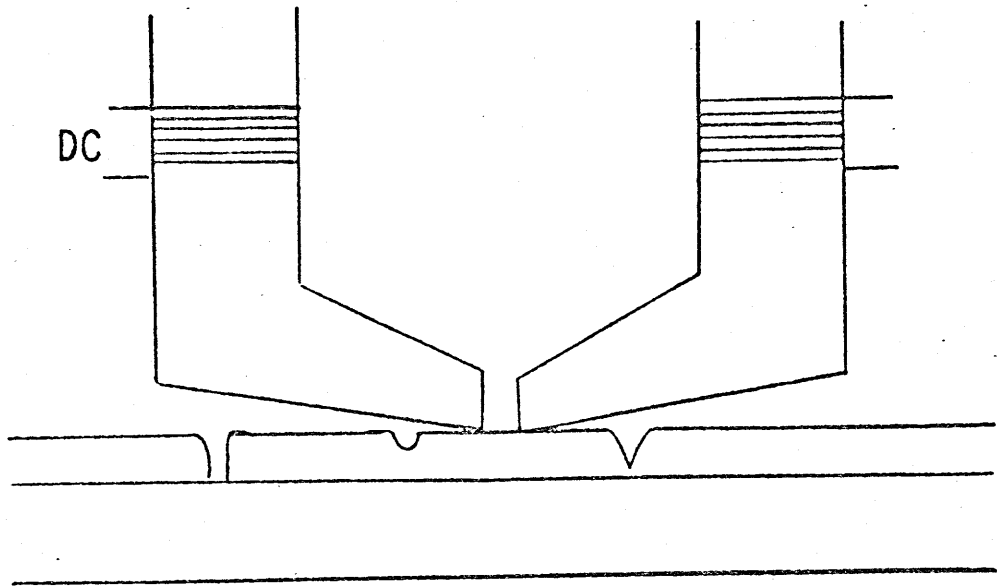
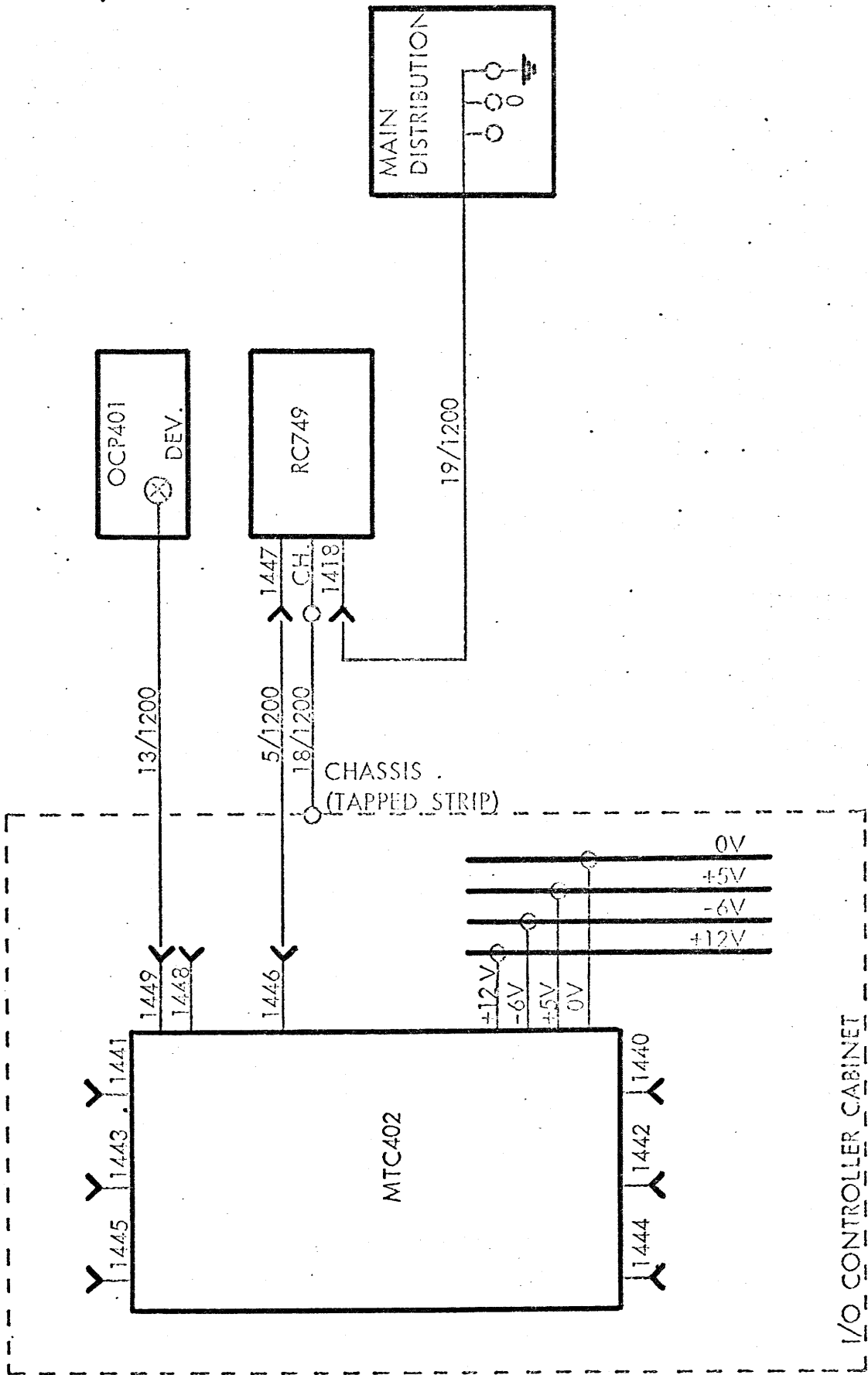

Fig. 2B



NOISE TEST

Fig. 3.



INTERCONNECTION PLAN FOR RC 4310 AND RC 749  
RC 4000 INSTALLATION:

Dwg. No. \_\_\_\_\_

PCBA Position List

<u>Pos.</u>	<u>PCBA</u>
TME 001	RC1508A-8
TME 002	RC1508A-8
TME 003	RC1508A-8
TME 004	RC1508A-8
TME 005	RC1508A-8
TME 006	RC1508A-8
TME 007	RC1508A-8
TME 008	RC1508A-8
TME 009	RC1508A-8
TME 010	RC1698-1
TME 011	RC1509A
TME 012	RC1682-1
TME 013	RC1609-1/1
TME 014	RC1688-1
TME 015	RC1609-1
TME 016	RC1663-1
TME 017	RC1663-1
TME 018	RC1663-1
TME 019	RC1667-1
TME 021	RC1501-2 \
TME 022	RC1501-2 /
TME 023	RC1501-2 /
TME 024	RC1501-2 /
TME 025	RC1501-2 /
TME 026	RC1501-2 /
TME 027	RC1501-2 /
TME 028	RC1501-2 /
TME 029	RC1501-2 /
TME 031	RC1668-1
TME 032	RC1668-1
TME 033	RC1668-1



Pos.	PCBA
TME 034	RC1668-1
TME 035	RC1668-1
TME 036	RC1668-1
TME 037	RC1668-1
TME 038	RC1668-1
TME 039	RC1668-1
TME 041	RC0856-7
TME 042	RC0897-1 2
TME 043	RC0897-1 2
TME 044	RC0871-1/11
TME 045	RC0854-1
TME 046	RC0894-1
TME 047	RC0899-1
TME 048	RC0894-1
TME 049	RC0853-5

200370MOJ

	C1	C2	
Circuit A	1300P Polystyren		
Circuit B	1300P Polystyren	1300P Polystyren	
Circuit C	100P Polystyren		
Circuit D	560P Polystyren		

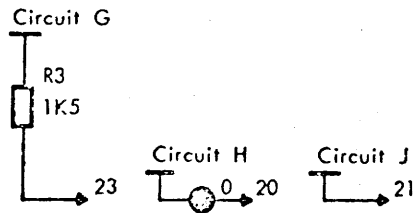
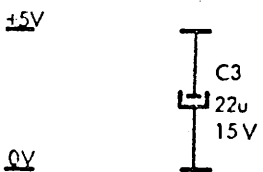
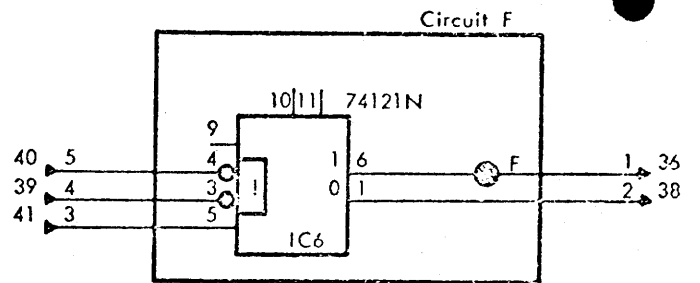
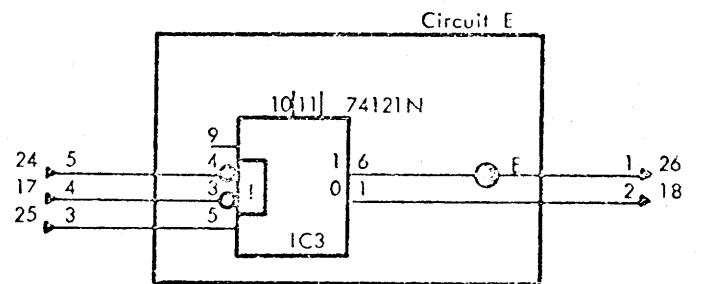
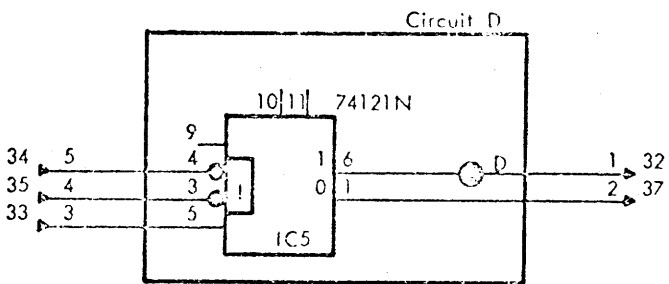
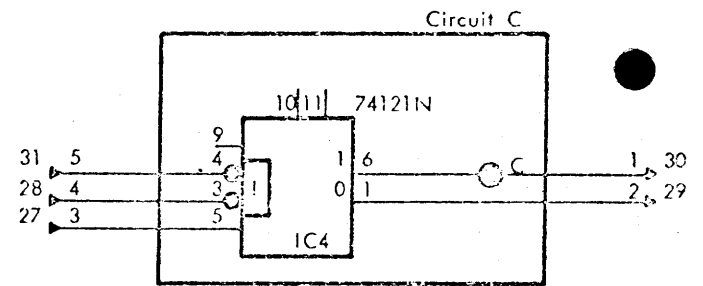
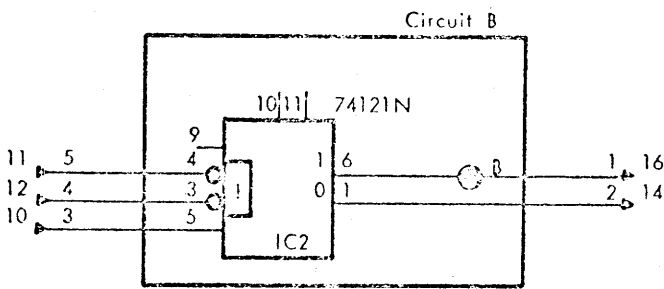
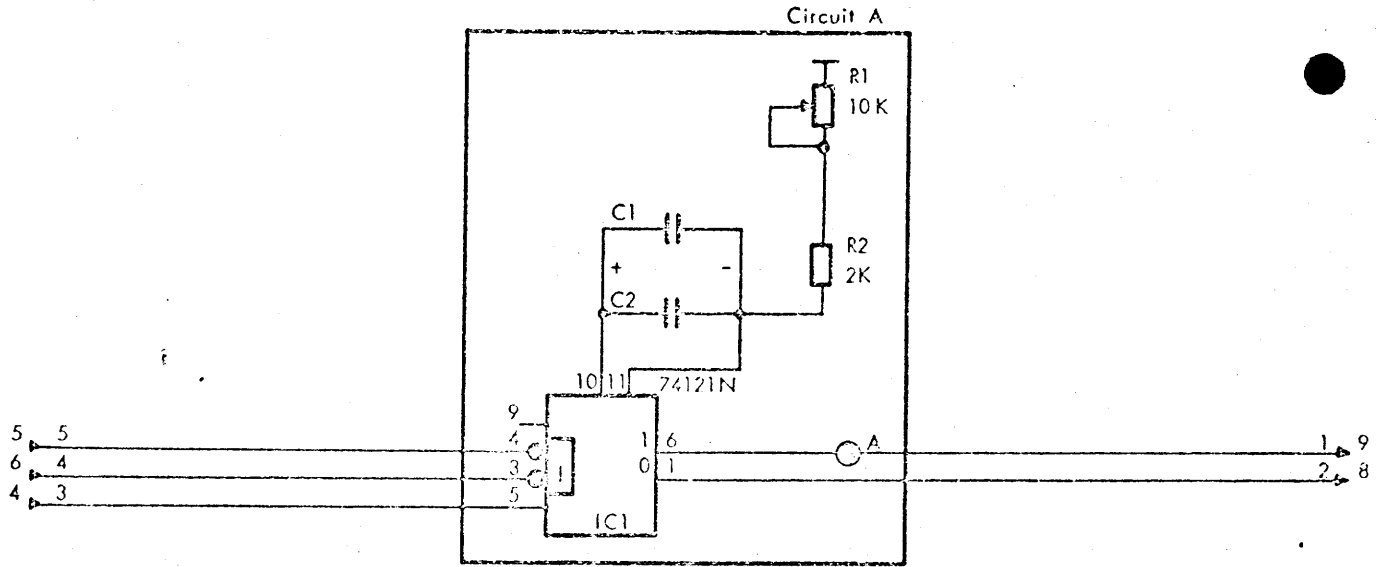

POWER REQUIREMENTS		
+5 V	PIN 22	152 mA
0 V	PIN 21	
POWER DISSIPATION 800 mW		

200972MOJ 200972MOGK

	C1	C2	
Circuit A	1uF	1uF	9mSec.
Circuit B	1uF	1uF	11,5mSec.
Circuit C	0u22F	0u1F	1,5mSec.
Circuit D	2n2		10uSec.
Circuit E	0u022F		100uSec.
Circuit F	150pF		0,8uSec.

RC4310

V23310

PCBA Variant

RC0909-1/19

4 stk. FUL910 erstattes af 4 stk. FUL914.

171269PTN

V21236

PCBA Variant

RC1609-1/1

Feb 639  
17.10.72  
Mick Jett  
SFT

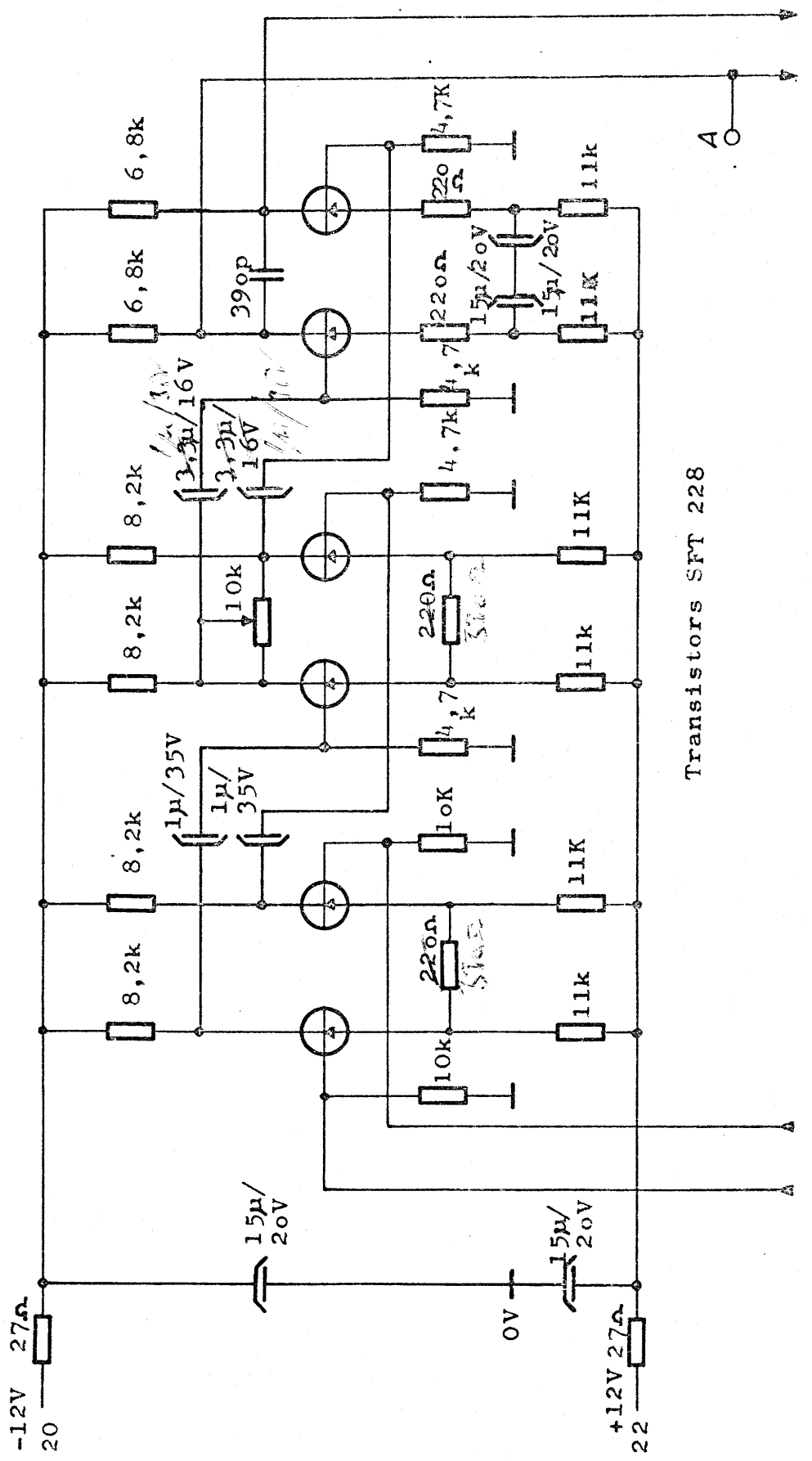

Transistors SFT 228

10 12  
from read  
head

2 3  
to read  
desk

	Unit T-17-9	Designed 9-12-64-HW	Reading Amplifier Pos B1-B9 Card (0) 101-7
	Approved	Drawn by 14-10-66 JA	
	Checked		
	Last Revision		
	Sheets _____ Sheet _____		

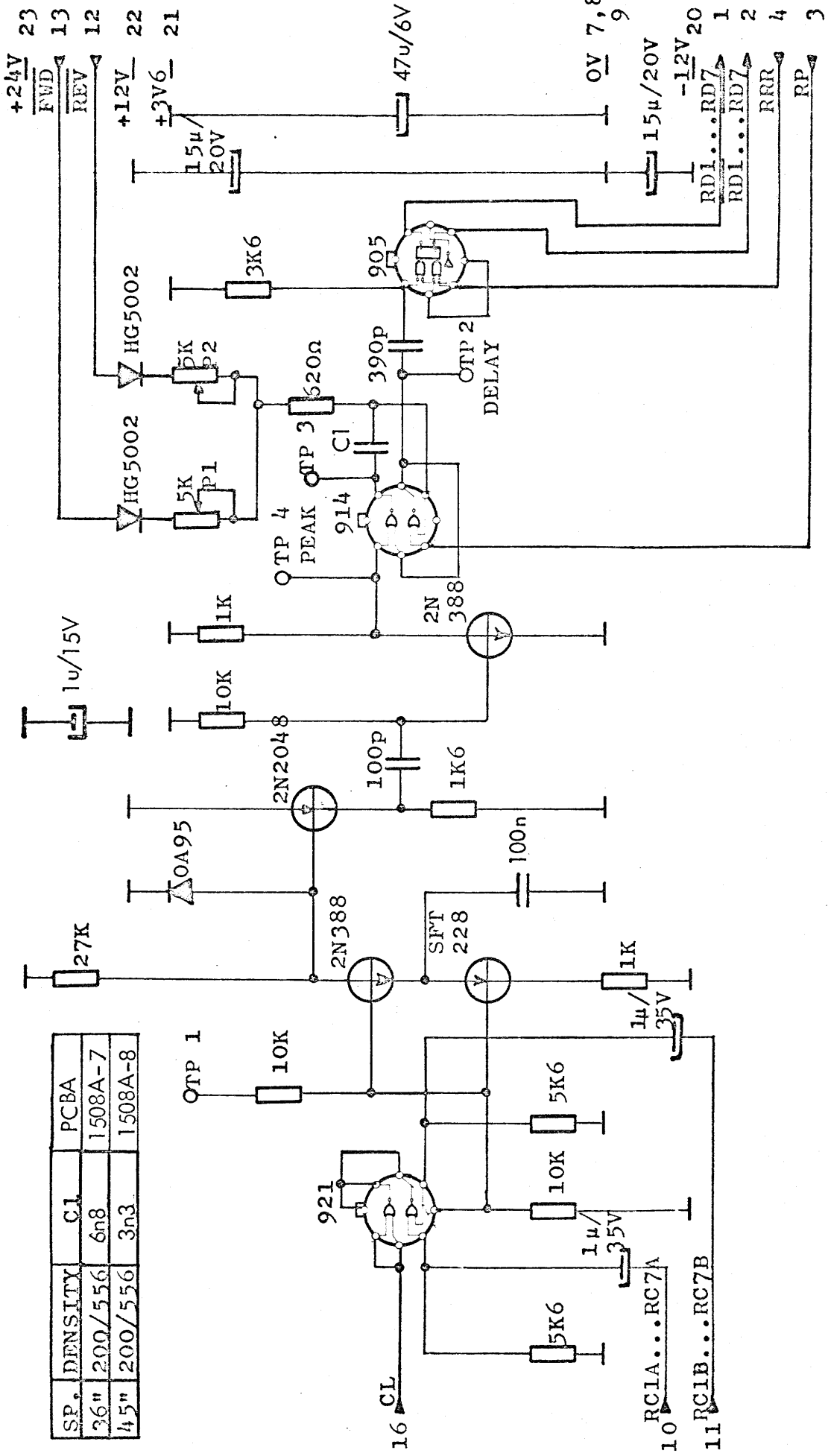

SP.	DENSITY	CL	PCBA
36"	200/556	6n8	1508A-7
45"	200/556	3n3	1508A-8

23.8.5.A-20C.m01

Unit: TM7



Designed \_\_\_\_\_  
 Approved \_\_\_\_\_  
 Checked \_\_\_\_\_  
 Last Revision 15.5.69.FE

READ DESKEW

Drawing No \_\_\_\_\_  
 Drawn by 6-7-67KS  
 Checked 17-7-67AAGR  
 1 Sheets Sheet 1  
 POS. 8-15 RC 1508 A

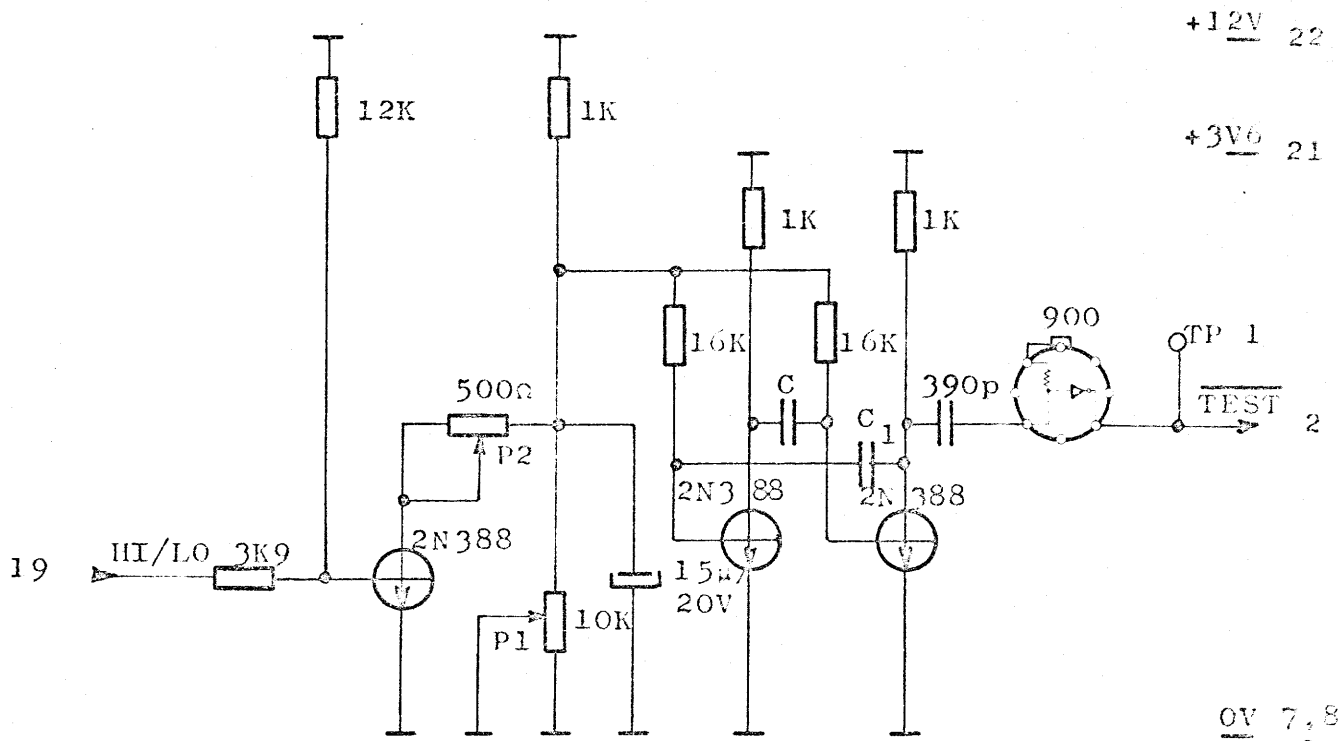

P1: ADJUSTMENT OF HI. P2: ADJUSTMENT OF LO.

PCBA	SP.	DENSITY	C	C <sub>1</sub>
1509A-1	36"	200/556	4n7	4n7
1509A-3	45"	200/556	4n7	3n3
1509A-5	45"	556/800	2n2	2n2

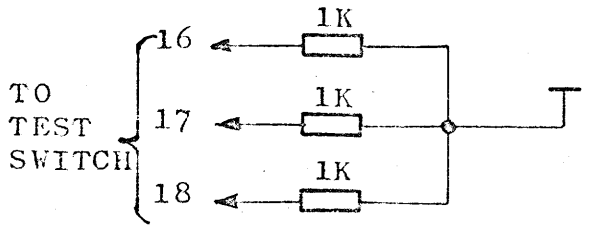
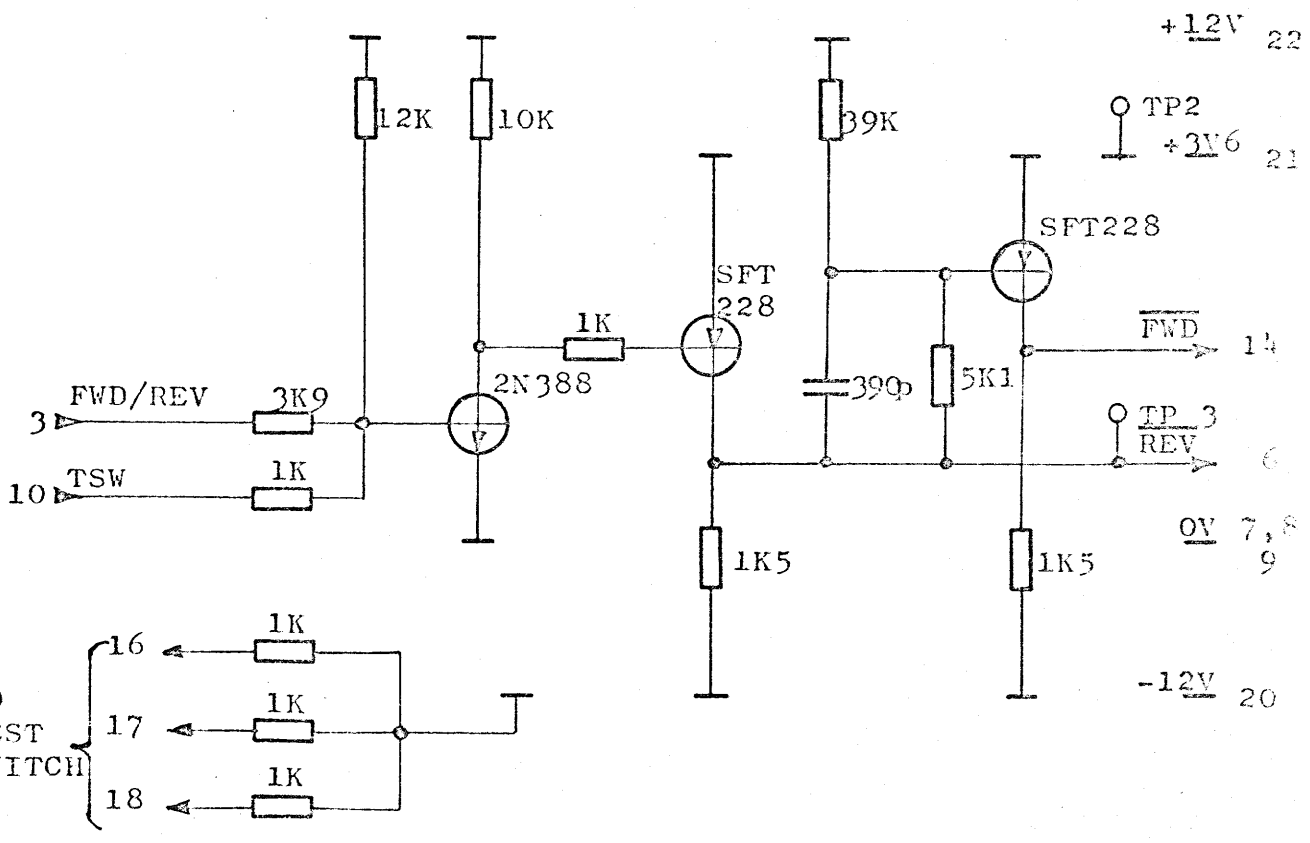
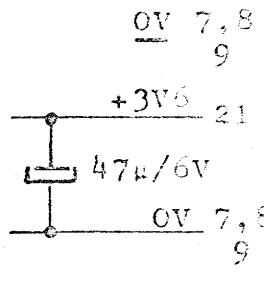

Unit: TM7  <b>CENTRALEN</b>	Designed Approved Checked Last Revision	<b>TEST GENERATOR AND FWD/REV AMPLIFIER</b>	Drawing No Drawn by 3-7-67KS Checked 17-8-67AAGT
	1 Sheets Sheet 1		POS. RC 1509A

22-B 1509A-202 m100



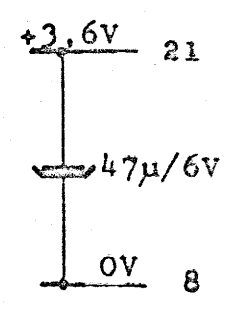
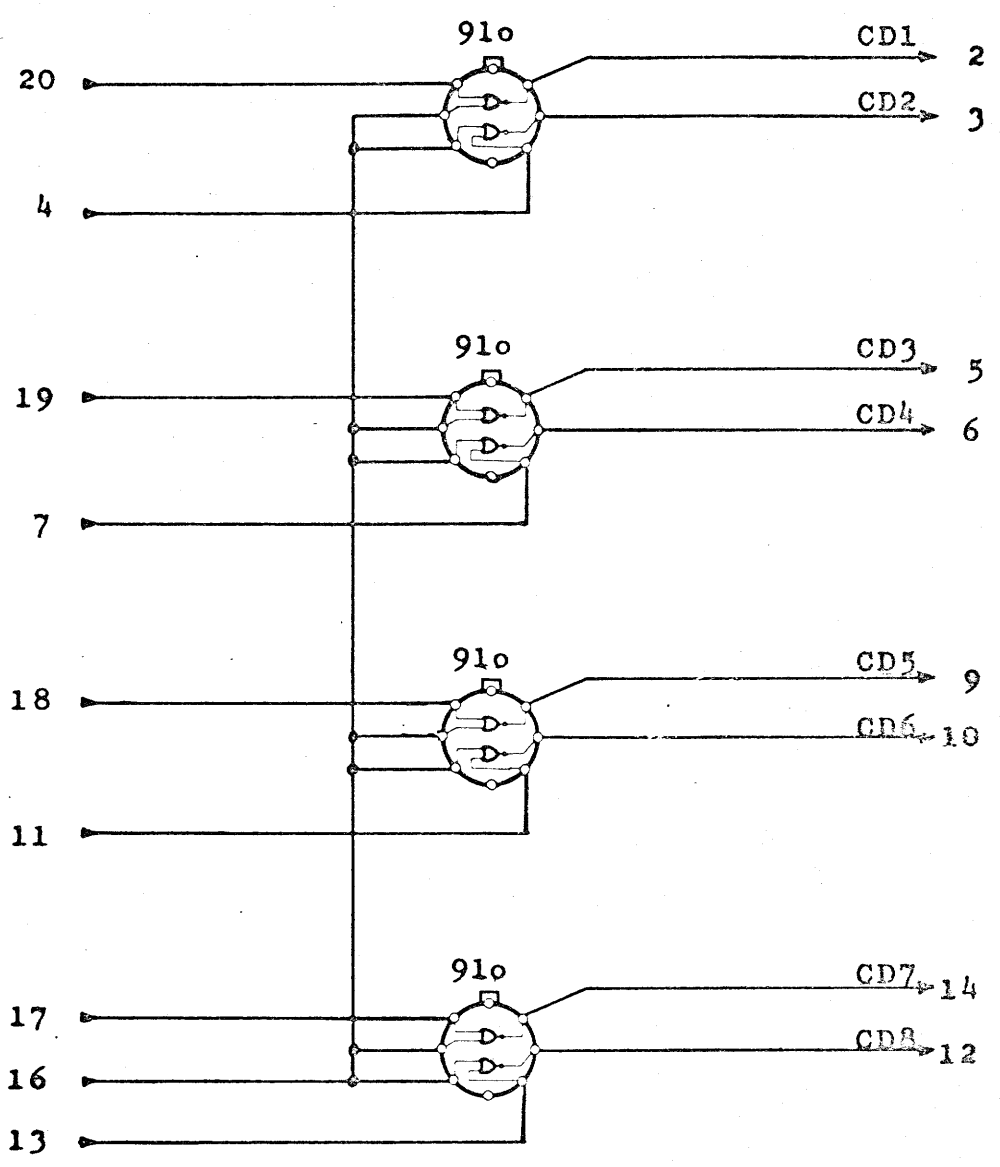

Unit: TM7-0	Designed 8-7-66-LW	CRC + Gate Write	— Sheets	Sheet —
	Approved		Pos A22	Card RC1609-1
	Drawn by 5-12-66 JA			
	Checked			
	Last Revision			

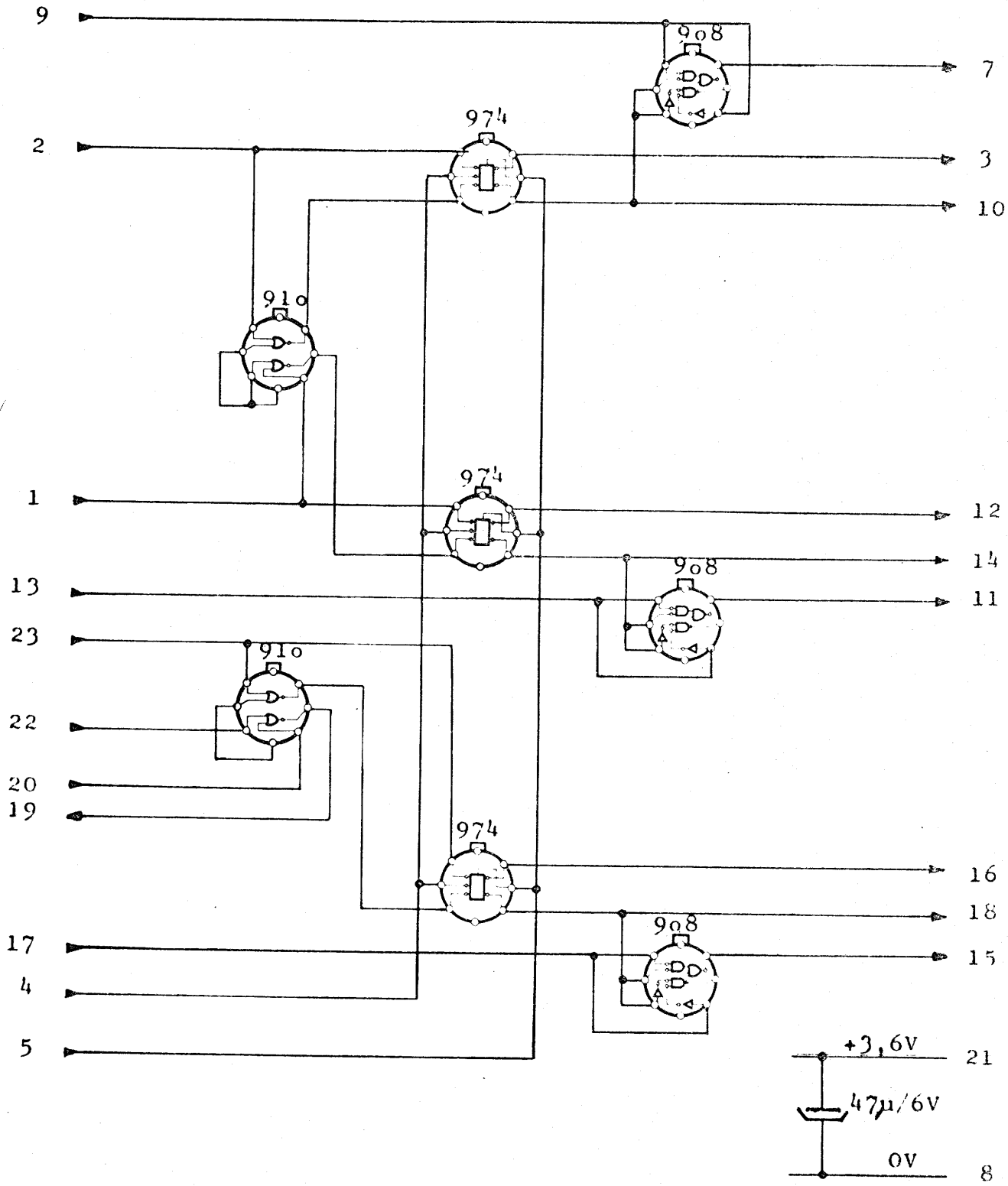

Unit TM7-9	14-10-66HW		
REGNE	Approved	CRC Register	Sheet
CENTRALEN	14-11-66-KS		A8-A10
	Last Revisor		A24-A26 RC1663-

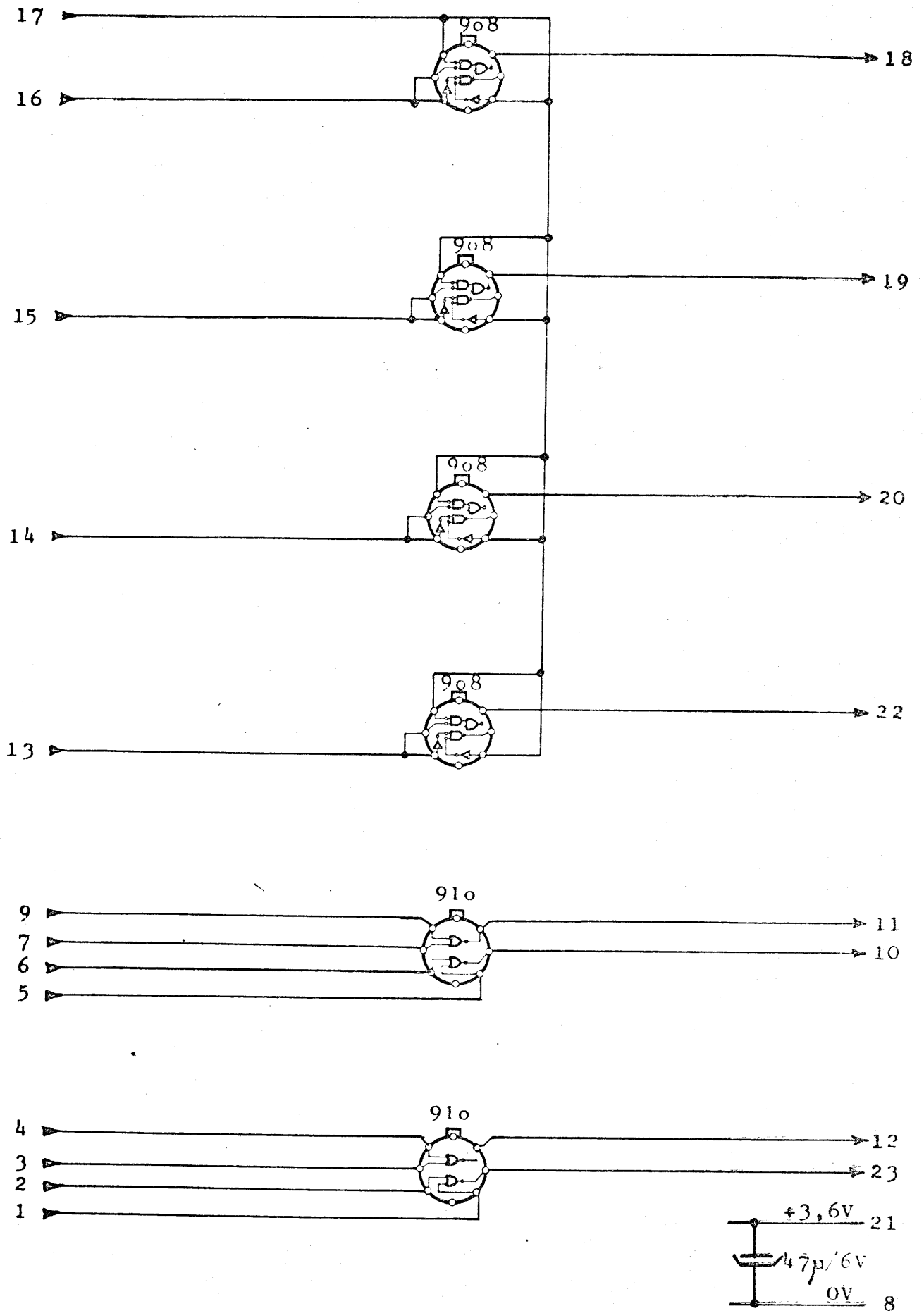

Unit TM7-9

**REGNE**  
CENTRALEN

Approved 28-10-66-HW

4-12-66 JA

Checked  
List Revision

CRC Inverting

Starts	Start
Pos A11	01
A23	RC1667-1

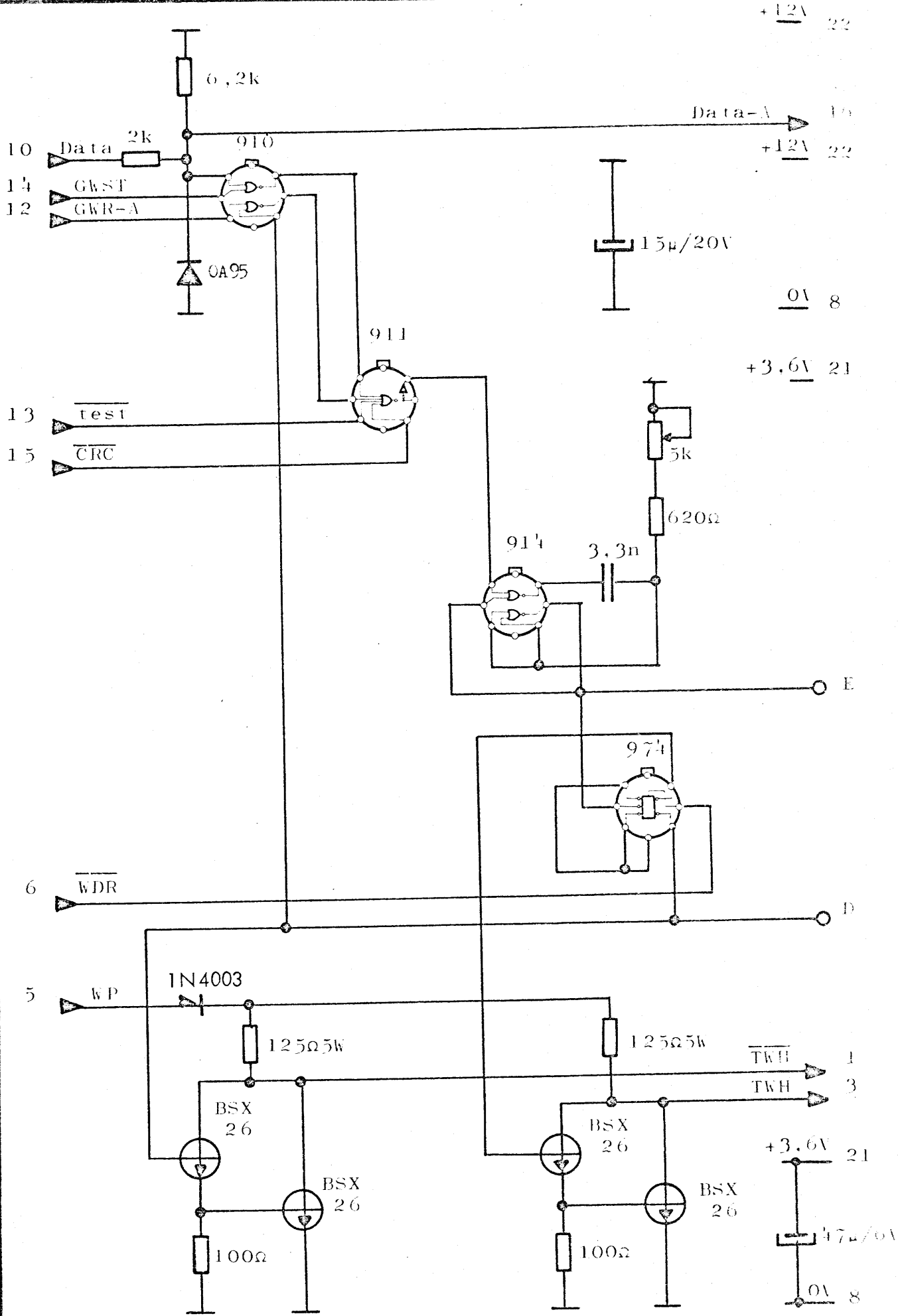

Unit: TM7-9

Designed 30-7-66 HW

Drawing No

Drawn by

Checked

REGNE  
CENTRALEN

Approved

Checked 28-11-67  
AAGH

Last Revision 160470 ERC

Writing Amplifier

Sheets

Sheet

POS:

319-B27

1668A-2

### Clipping Level

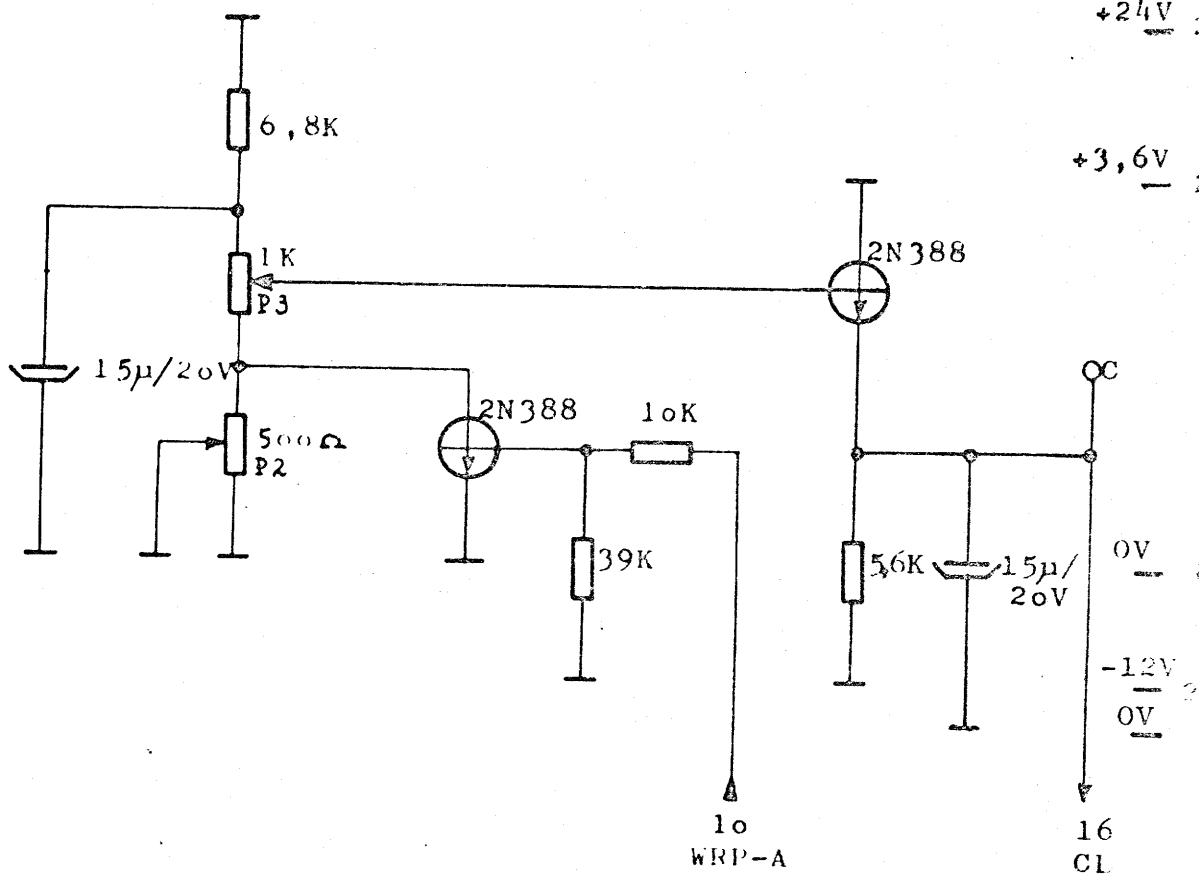

### +3.6V Regulator

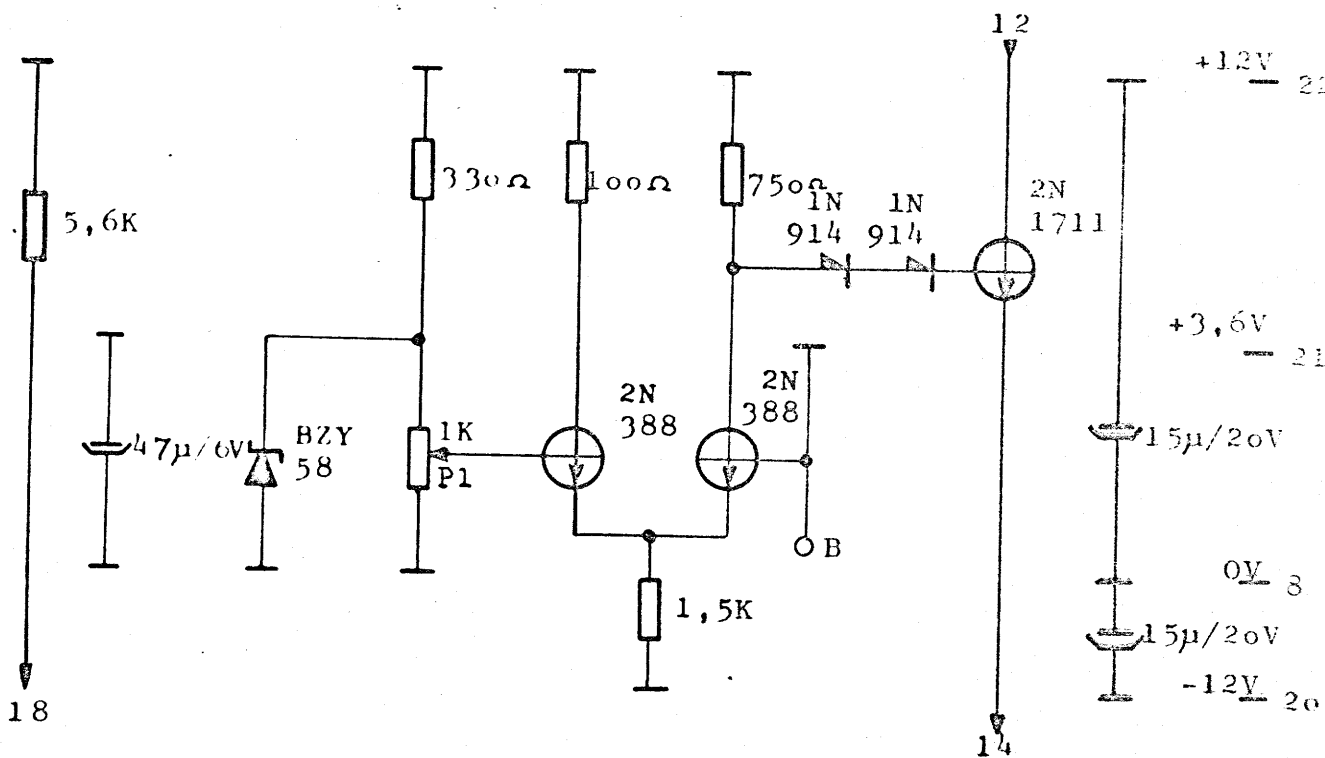

Unit	TM7-9	Designed	15-12-66 HV
		Approved	
		Drawn	10-1-67 KS
		Checked	
		Last Revision	29-10-68-PE

Clipping Level  
And  
+3.6V Regulator

Sheet	1 of 1
Pos	A15
Card	RC1682-1

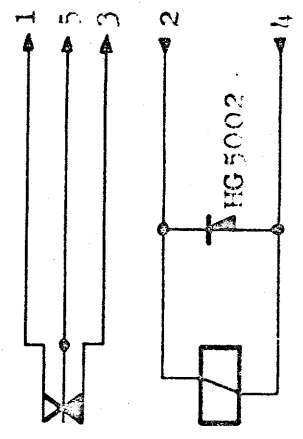
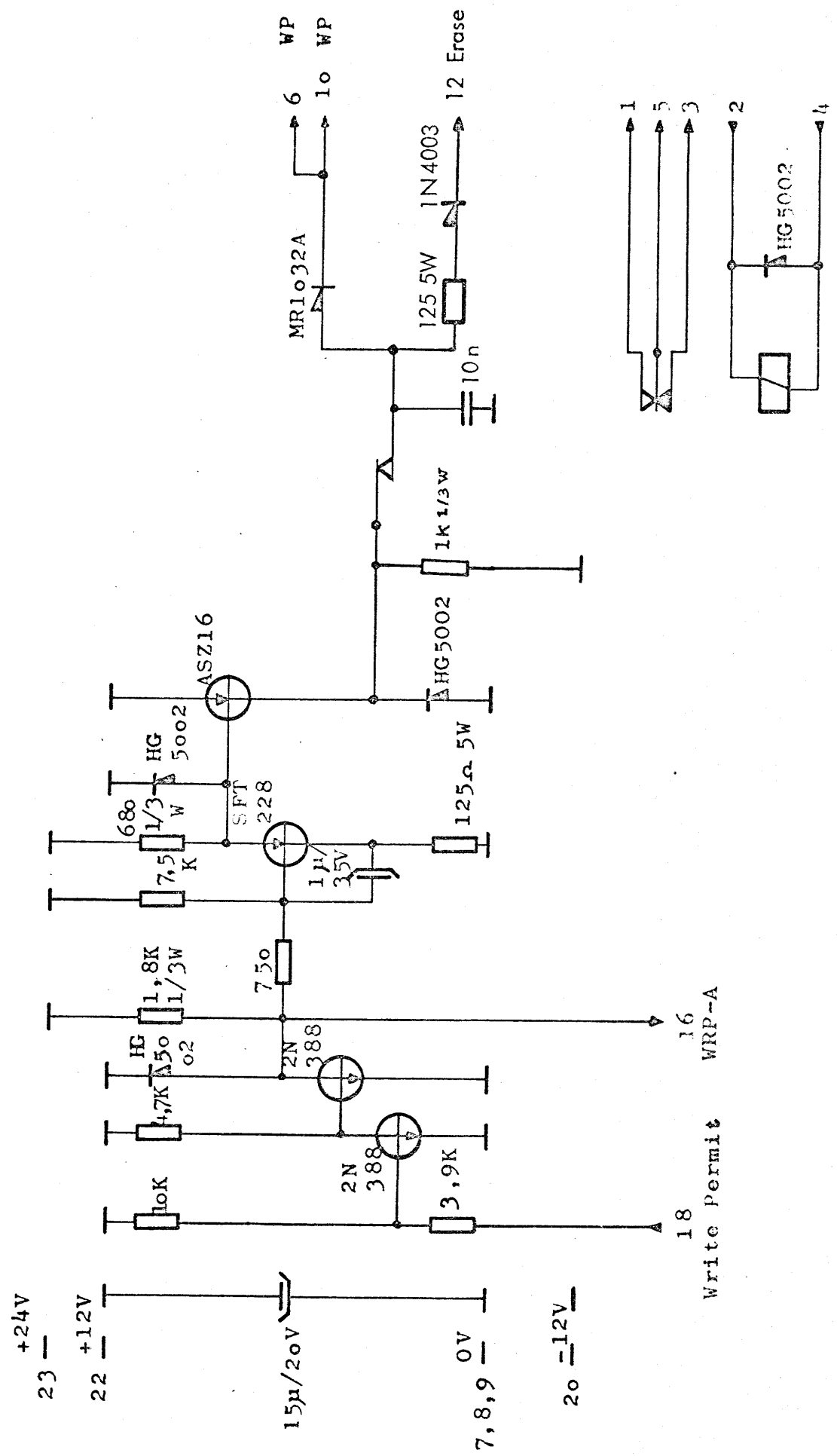

18 Write Permit  
16 WRP-A

	Unit: TM7-9	Designed 9-12-64-HW	Write Power Pos 28 Card 1688A-2
	Approved	Drawn by 5-12-66 JA	
	Checked	Last Revision 160470 ERC	
	Sheets _____ Sheet _____		

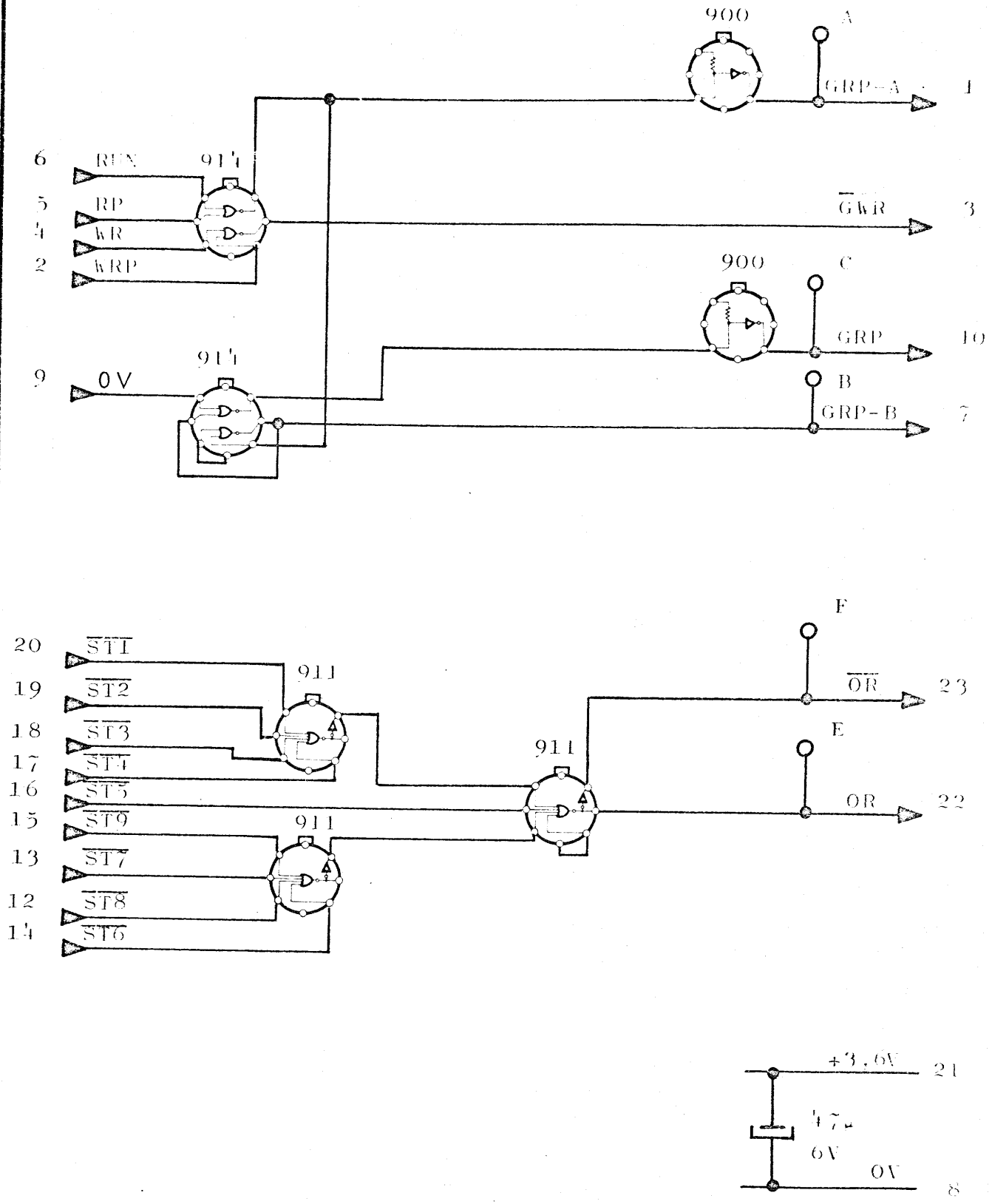

Unit: TM7-9

Designed 9-11-67  
AAGR

Approved

Checked

Last Revision 15.5.69

CONTROL GATING  
CIRCUITS

Drawing No  
Drawn by  
Checked

Sheets  
POS  
A19

Sheet  
RC1698-1



FORM 302-V-78 (9)

Set fra trådningsiden.

49 48 47 46 45 44 43 42 41

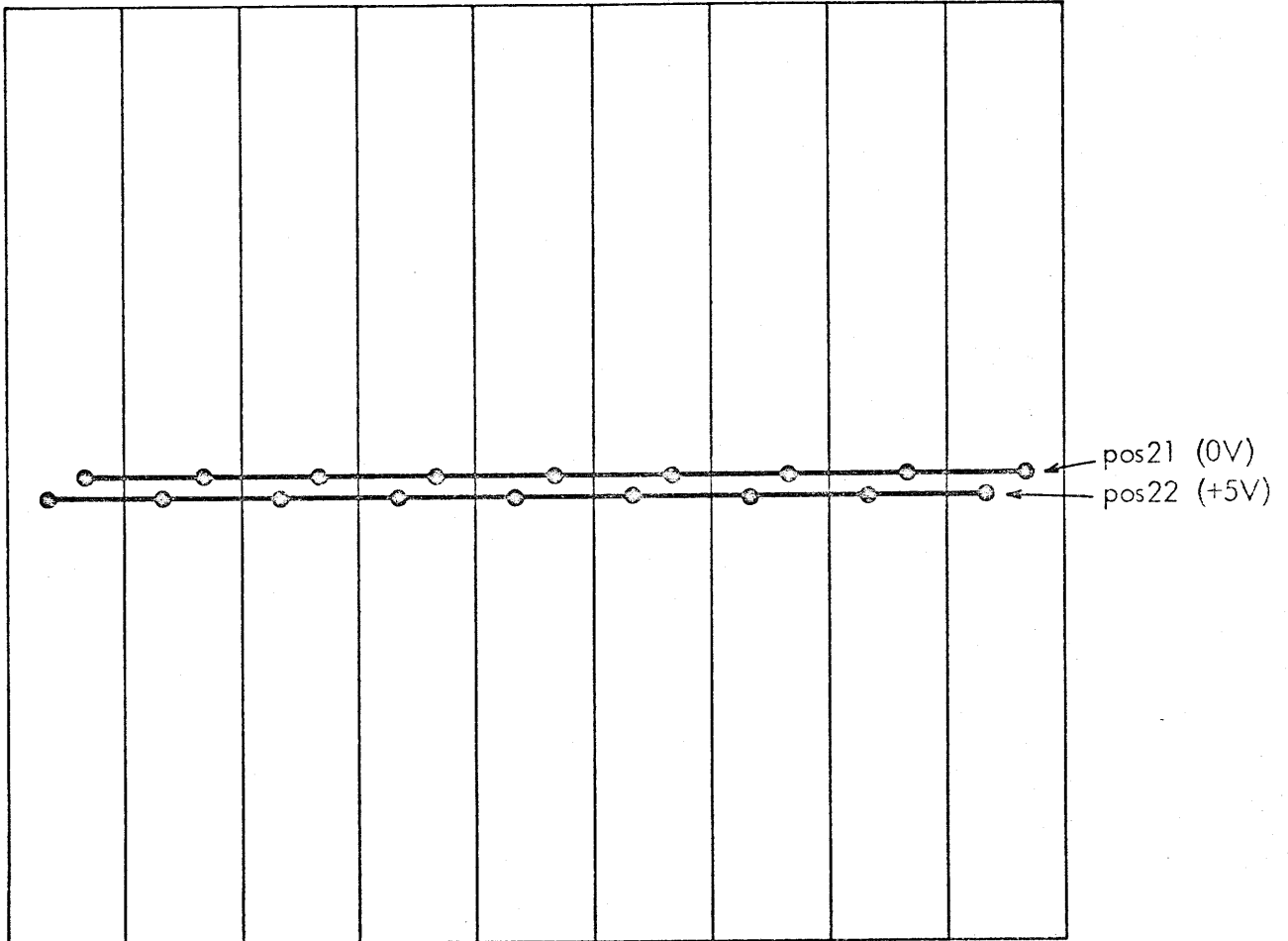

Tværtrådene lægges i 1 $\phi$  fortrinnet tråd isoleret med teflon.  
Elco - kontakter: 0V: Bus - fork - contact 50 - 7015 - 9220.  
+5V: Bus - fork - contact 50 - 7015 - 9210.

Form 302-VV-S 3 2

Unit: TME301

**REGNE**  
CENTRALEN

Designed 060470MAJ

Approved

Checked

Last Revision

Powertrådnng

Drawing No V21366

Drawn by

Checked

Sheets

Sheet



Seen from Wiring Side.

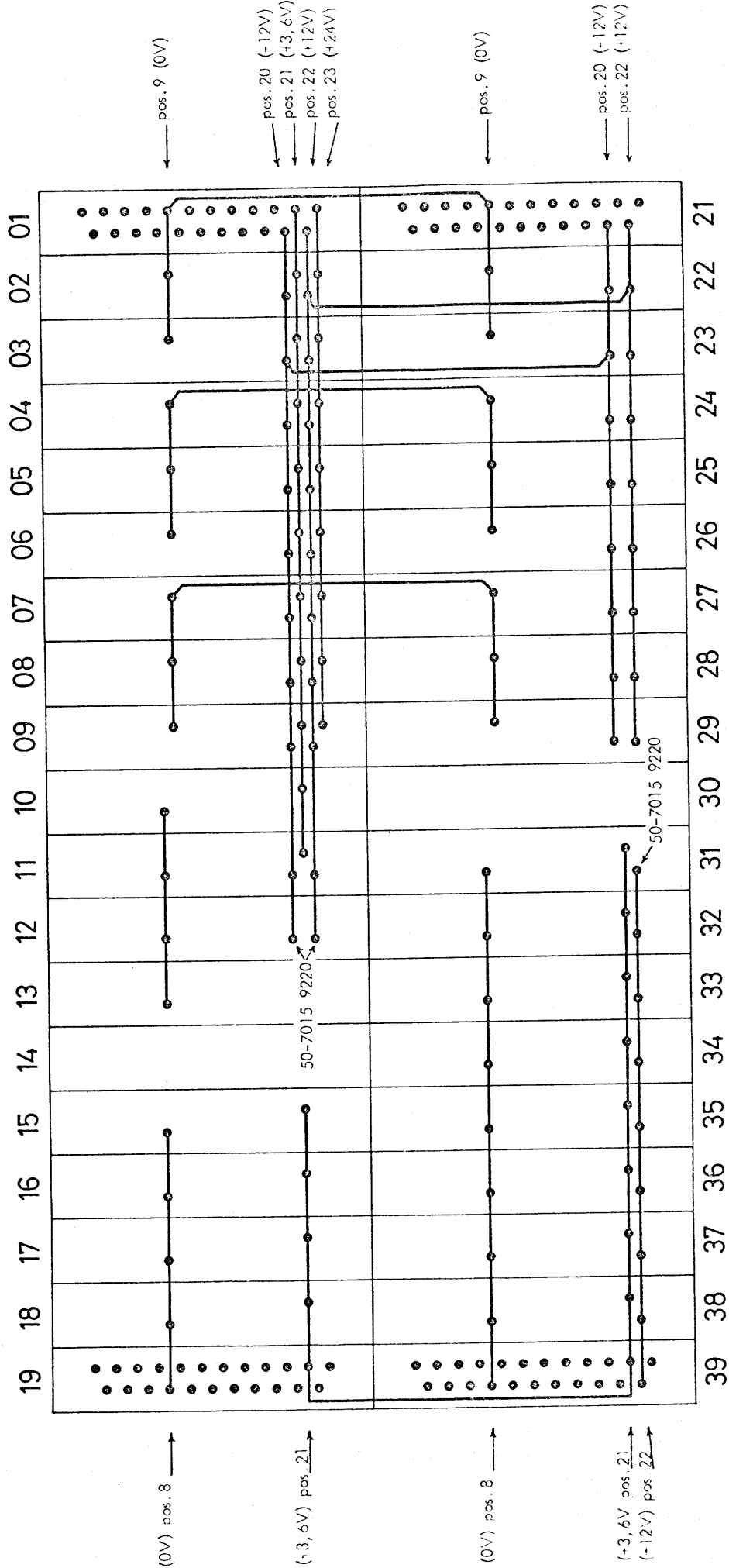

Power Wiring

Al power trådning lægges i 1<sup>o</sup> fortinnet tråd isoleret med teflon. Elco kontakter skal være type: Bus-fork contact 50-7015 9210 og 50-7015 9220. Type 50-7015 9210 anvendes hvor 50-7015 9220 ikke er angivet.

Seen from mountingside.

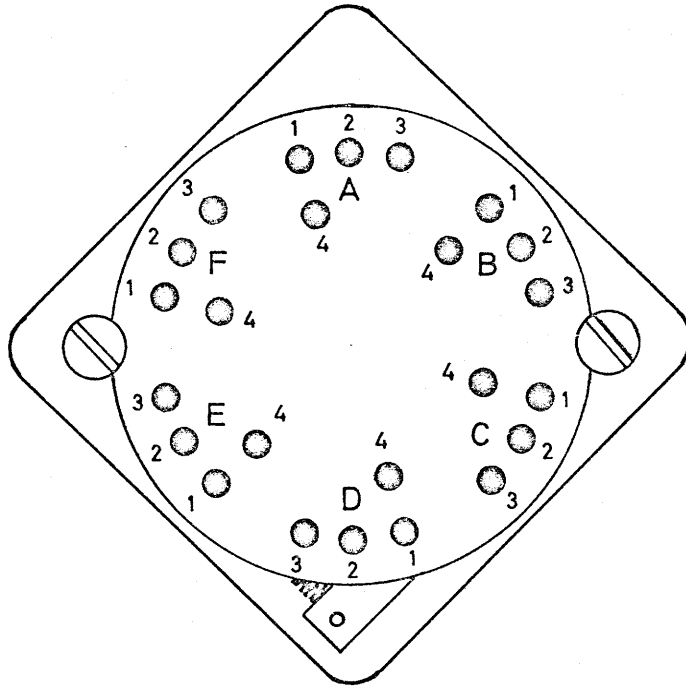

ELMA switch 03,6 x 3 still.

JØG 100369

RC4000

V20850

Pin positions on ELMA switch.

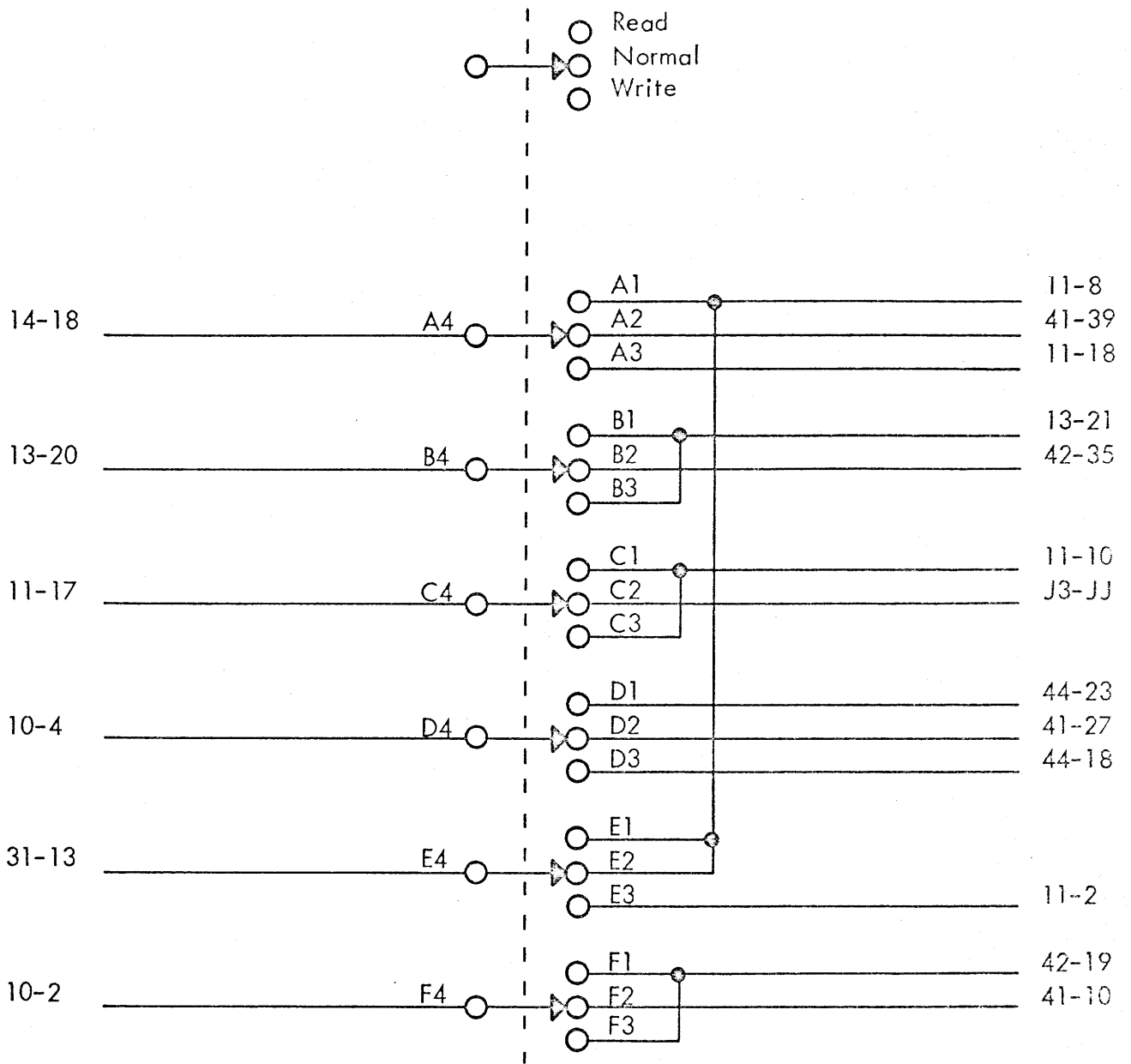

171269JΦG

Replaced by Dwg. No.

due to ECN

Replaces Dwg. No.

Design Check

Dwg. Office Check

Drawn by

Designed by

130470 MOJ

A/S REGNENCENTRALEN

TME 301  
Spændingstrådning.

+24V:

T3 - - ( J3 - A )  
T3 - - ( 12 - 23 ) -- ( 14 - 23 )  
T3 - - +24V plan ved pos. 9

+12V:

T2 - - ( J3 - B ) -- ( J3 - C )  
T2 - - ( 14 - 22 )  
T2 - - +12V plan ved pos. 29  
T2 - - +12V plan ved pos. 31  
T2 - - Q1C  
( 12 - 12 ) - - +12V plan ved pos. 12

+12V:

T5 - - ( 1447 - CM ) -- ( 1447 - CP )  
T5 - - ( 42 - 1 ) -- ( 43 - 1 )

-12V:

T1 - - ( J3 - D )  
T1 - - ( 14 - 20 ) -- ( 41 - 4 ) -- ( 49 - 4 )  
T1 - - -12V plan ved pos 29.  
T1 - - ( 14 - 4 )

-6V:

T4 - - ( 1447 - CK )  
T4 - - ( 42 - 2 ) -- ( 43 - 2 )

+5V:

T6 - - ( 1447 - CU ) -- ( 1447 - CS )  
T6 - - ( 1447 - CX ) -- ( 1447 - CW )  
T6 - - +5V plan ved pos. 41

Al trådning lægges i 0.25 mm<sup>2</sup> blød tråd.

Forbindelser til +24V plan, +12V plan, -12V plan, -6V plan og +5V plan sker ved lodning.

Unit

TME 301

Dwg. No.

V 21234

Spændingstrådning

TME 301  
Spændingstrådning.

+3.6V:

( 12 - 14 ) - - Q1B  
Q1E - - ( 12 - 21 ) -- ( 13 - 21 )  
Q1E - - +3.6V plan ved pos. 11  
Q1E - - +3.6V plan ved pos. 31

0V:

T7 - - ( J3 - NN ) -- ( J3 - MM ) -- ( J3 - LL ) -- ( J3 - E )  
T7 - - ( 1447 - CZ ) -- ( 1447 - CY )  
T7 - - ( 1447 - CN ) -- ( 1447 - CR ) -- ( 1447 - CT ) -- ( 1447 - CL )  
-- ( 1447 - CD ) -- ( 1447 - CV )  
T7 - - ( 14 - 9 )  
T7 - - 0V plan ved pos. 41  
T7 - - 0V plan ved pos. 31  
T7 - - 0V plan ved pos. 29  
T7 - - 0V plan ved pos. 26  
T7 - - 0V plan ved pos. 23  
T7 - - 0V plan ved pos. 10  
T7 - - 0V plan ved pos. 15

Chassis:

CH. - - ( 1447 - DA ) -- ( 1447 - DB )  
CH. - - ( J3 - N ) -- ( J3 - P ) -- ( J3 - R )

Al trådning lægges i 0.25 mm<sup>2</sup> blød tråd  
Forbindelser til +3.6V plan og 0V plan sker ved lodning.  
Forbindelser til CH. sker ved kabelsko AMP, rød.

Replaced by Dwg. No.

due to ECN

Replaces Dwg. No.

Design Check

Dwg. Office Check

Drawn by

Designed by

JZ1269 MAJ

A/S REGNECENTRALEN

Unit	TME 301
Dwg. No.	V 21235

Spændingstrådning

171269JΦG

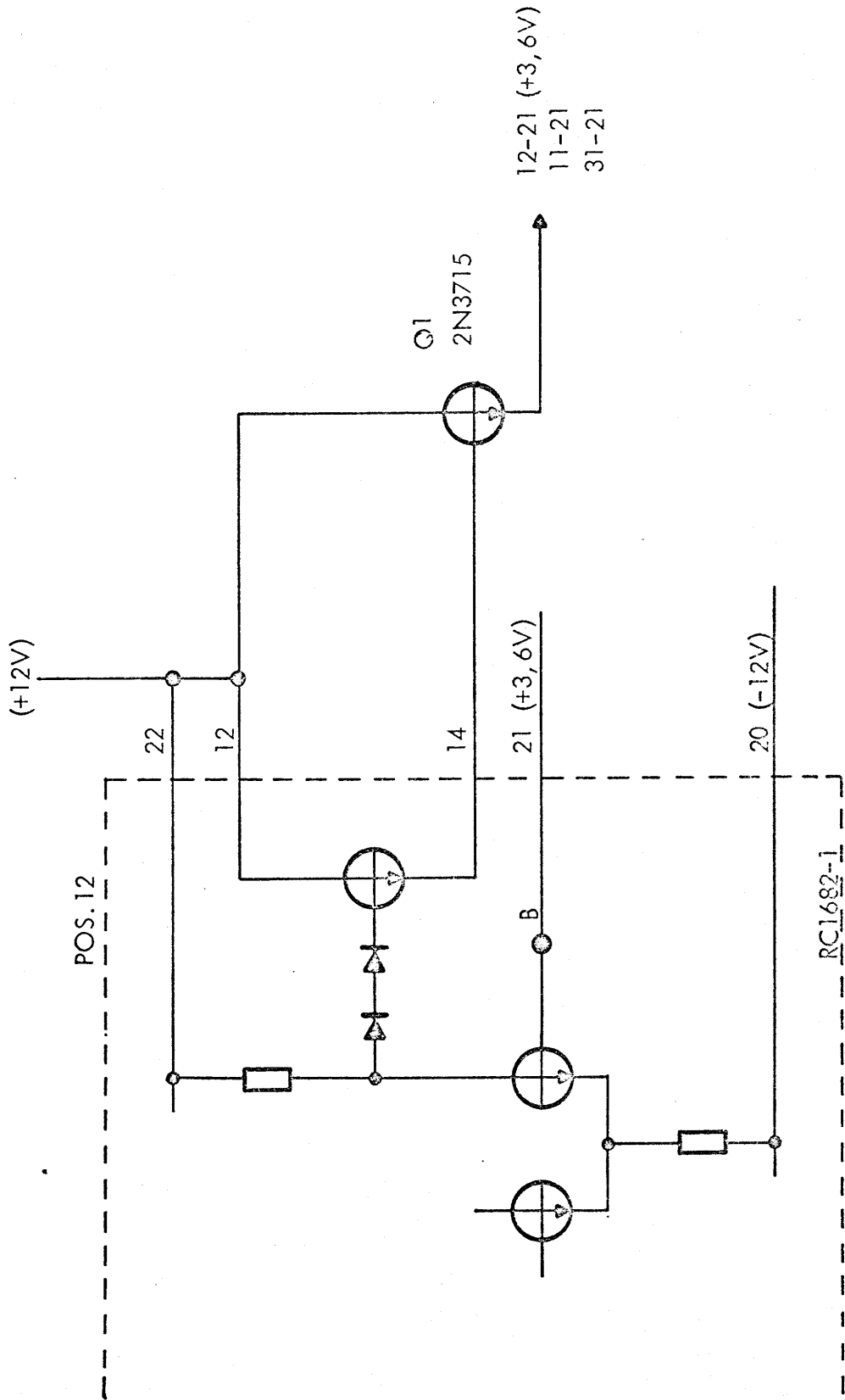

TME301

+3,6V Regulator

V21227

Circuit Diagram

130569J0G 010570HA 210770 19083030G V11406

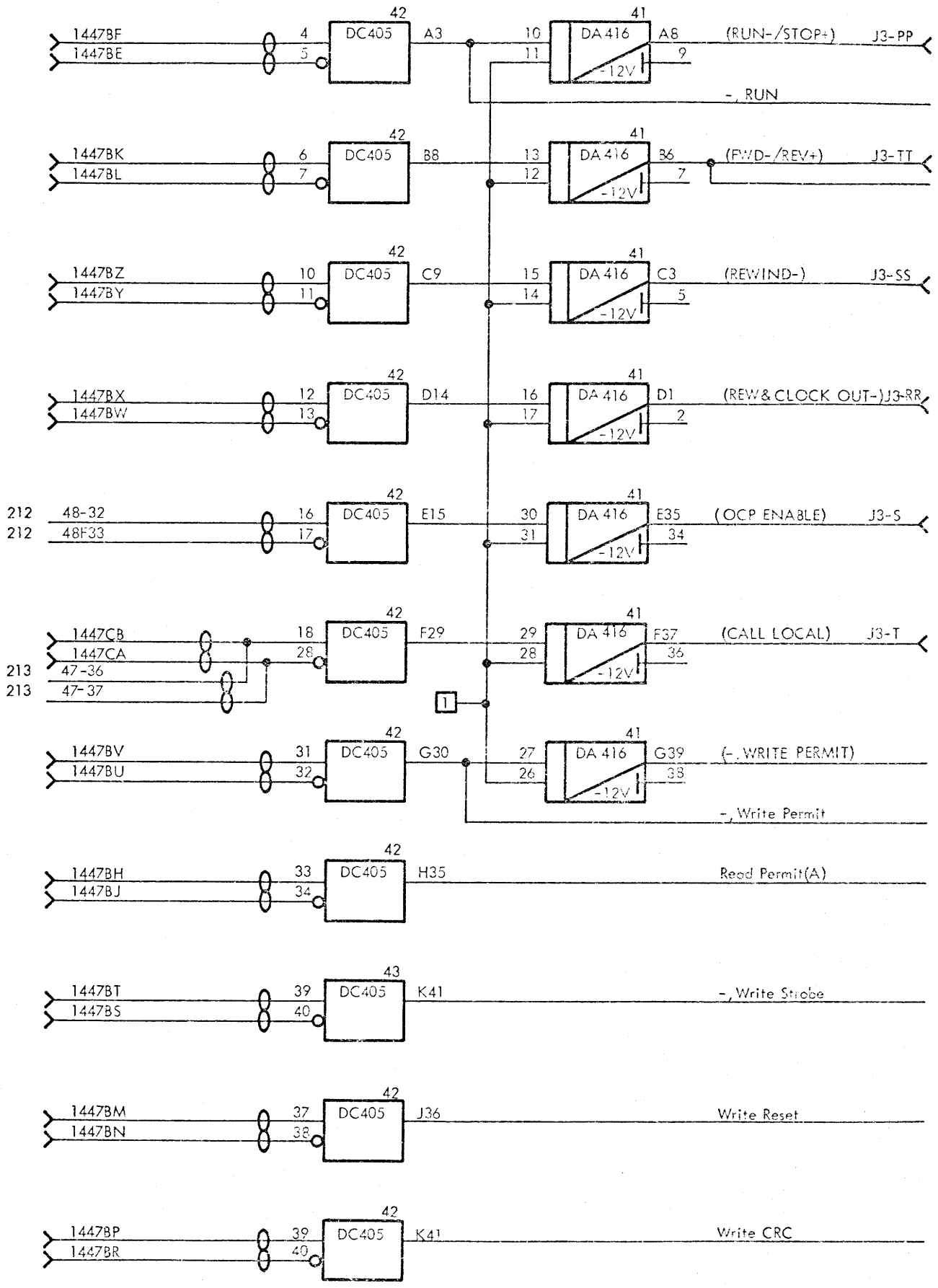

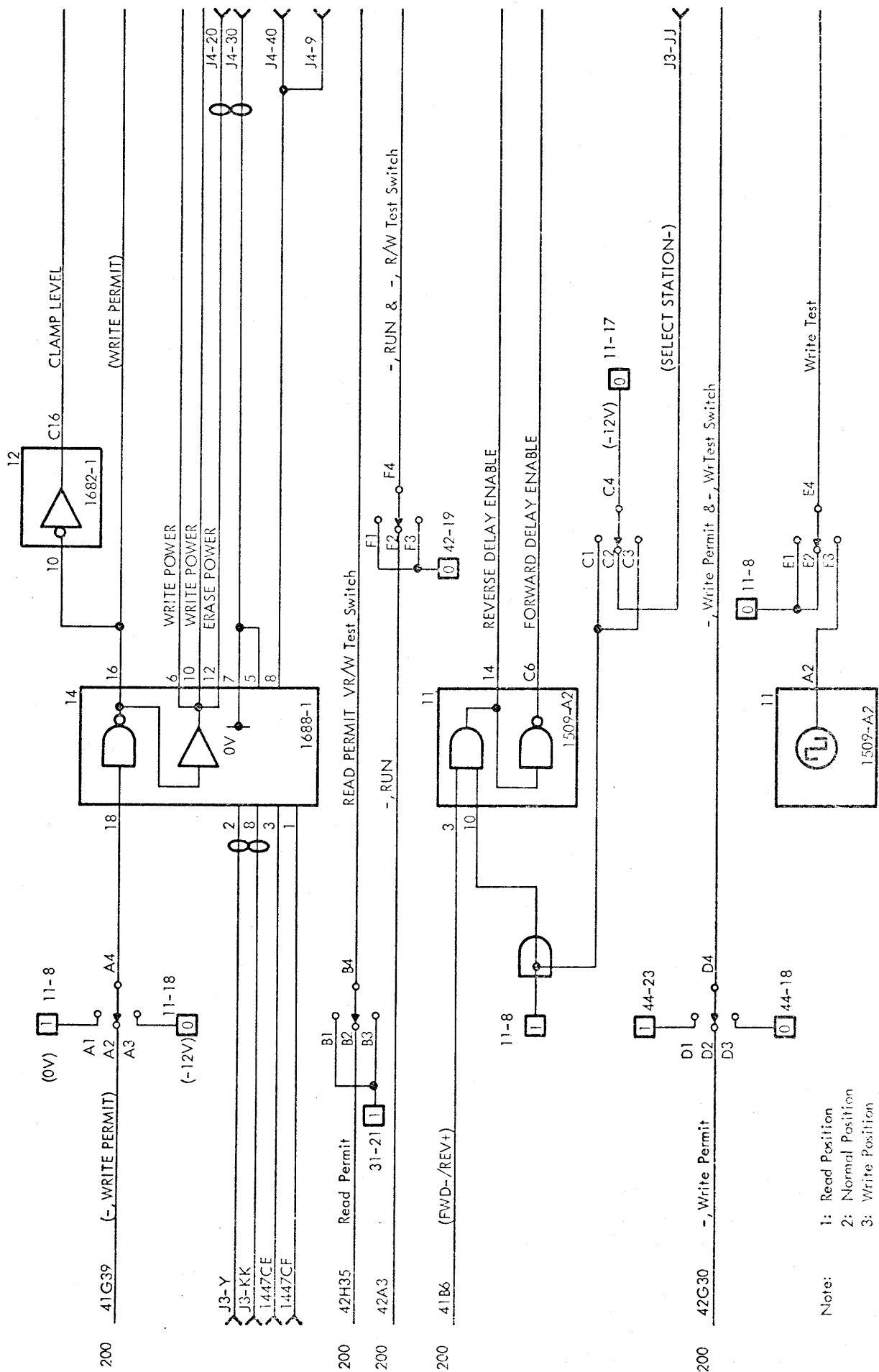

Note:  
 1: Read Position  
 2: Normal Position  
 3: Write Position



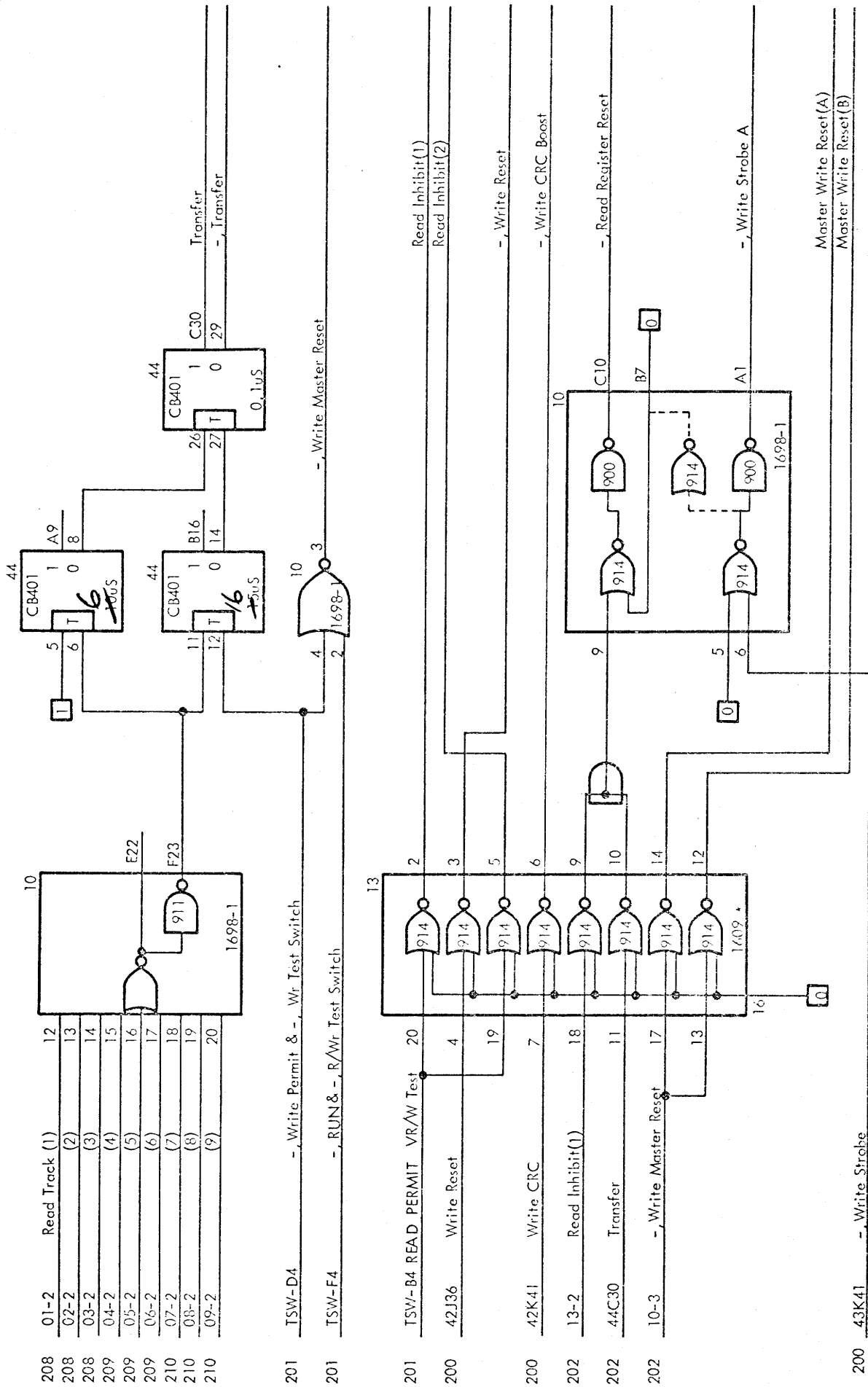

130569JQG 010570HA 210770 (4C 170870 J06G V11409

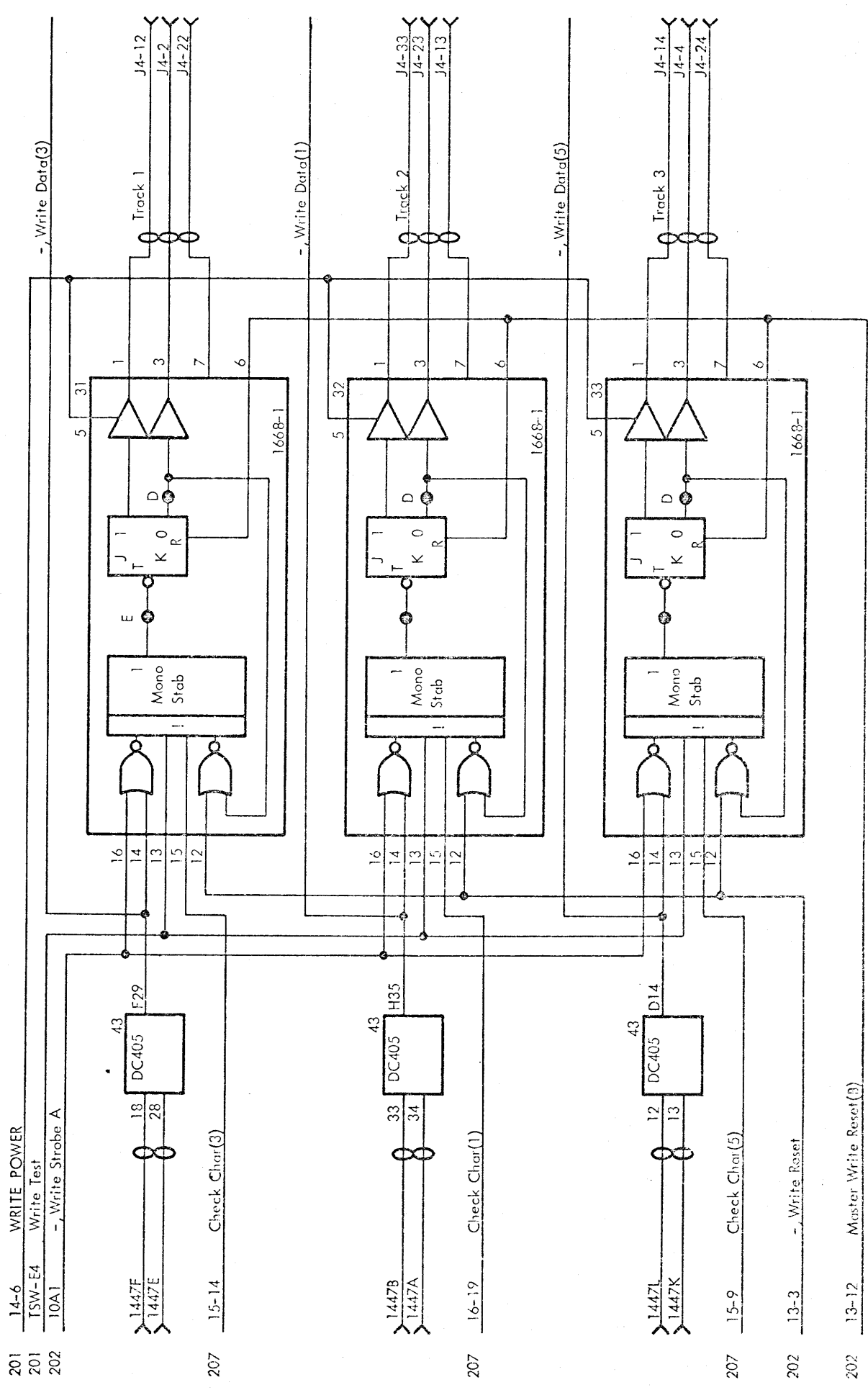

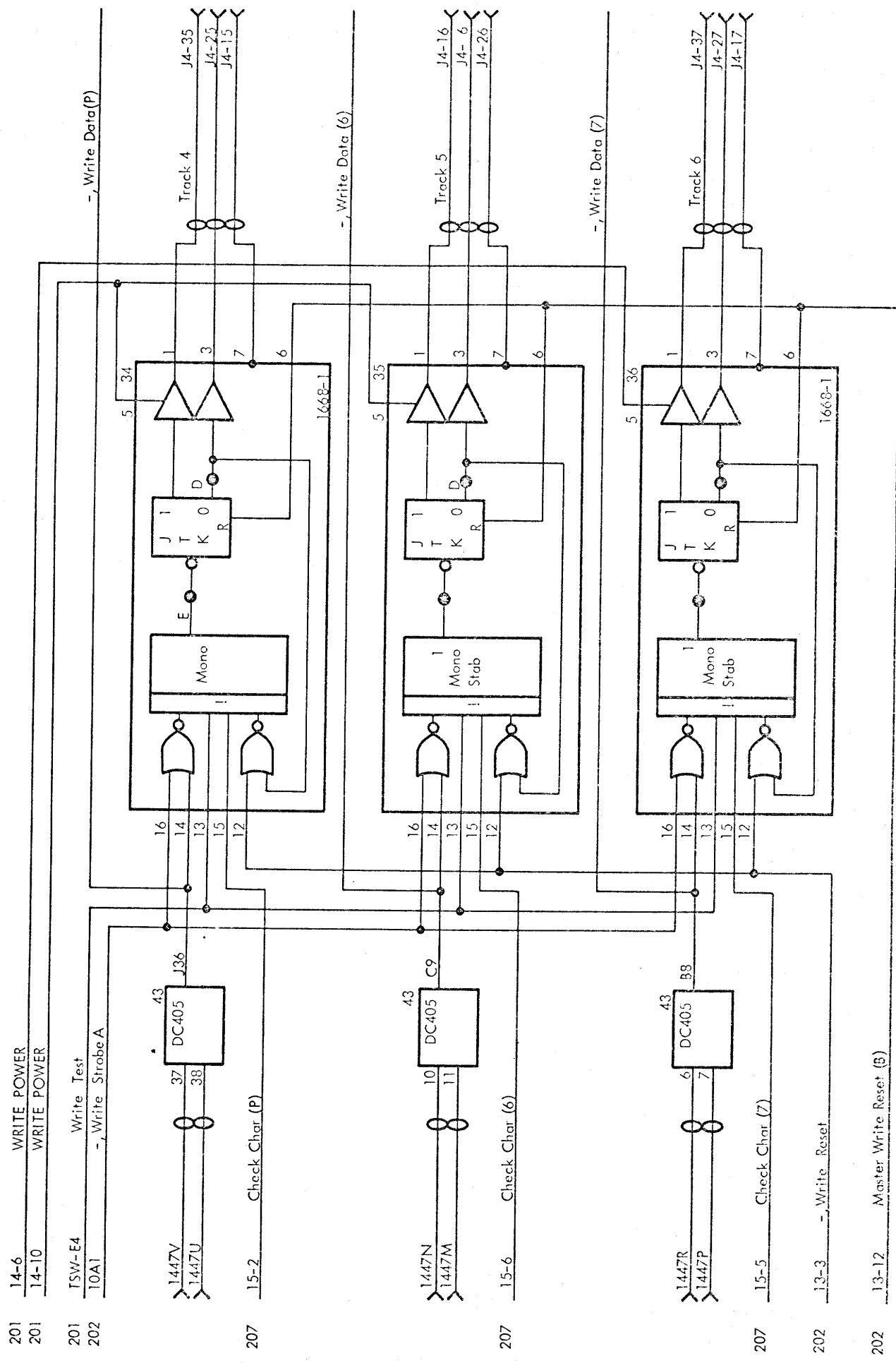

DATA RECEIVERS AND WRITE AMPLIFIERS

Logic Diagram

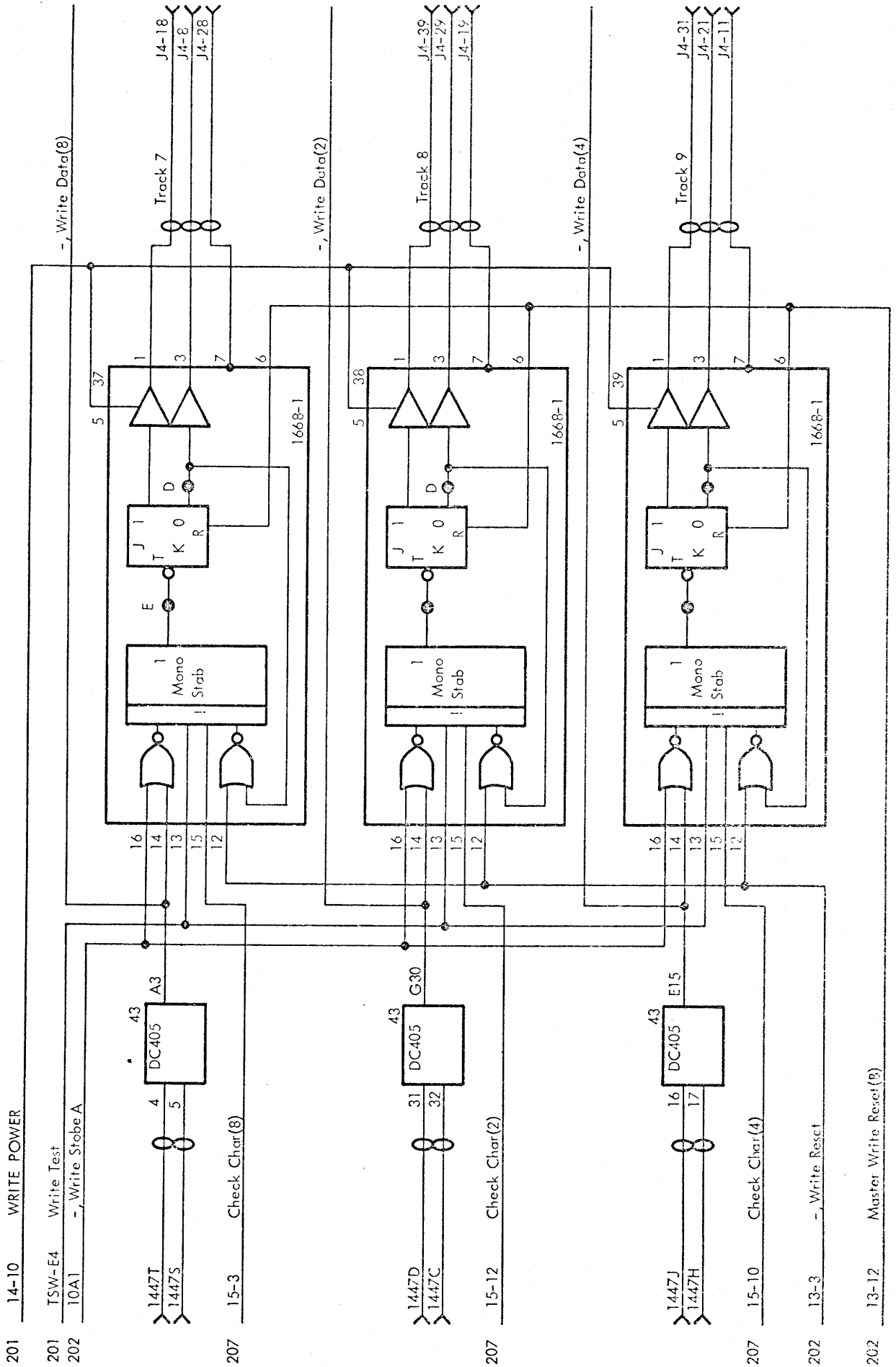

130568JΦG 010570HA 210770 ttc 170870 J06 V11412

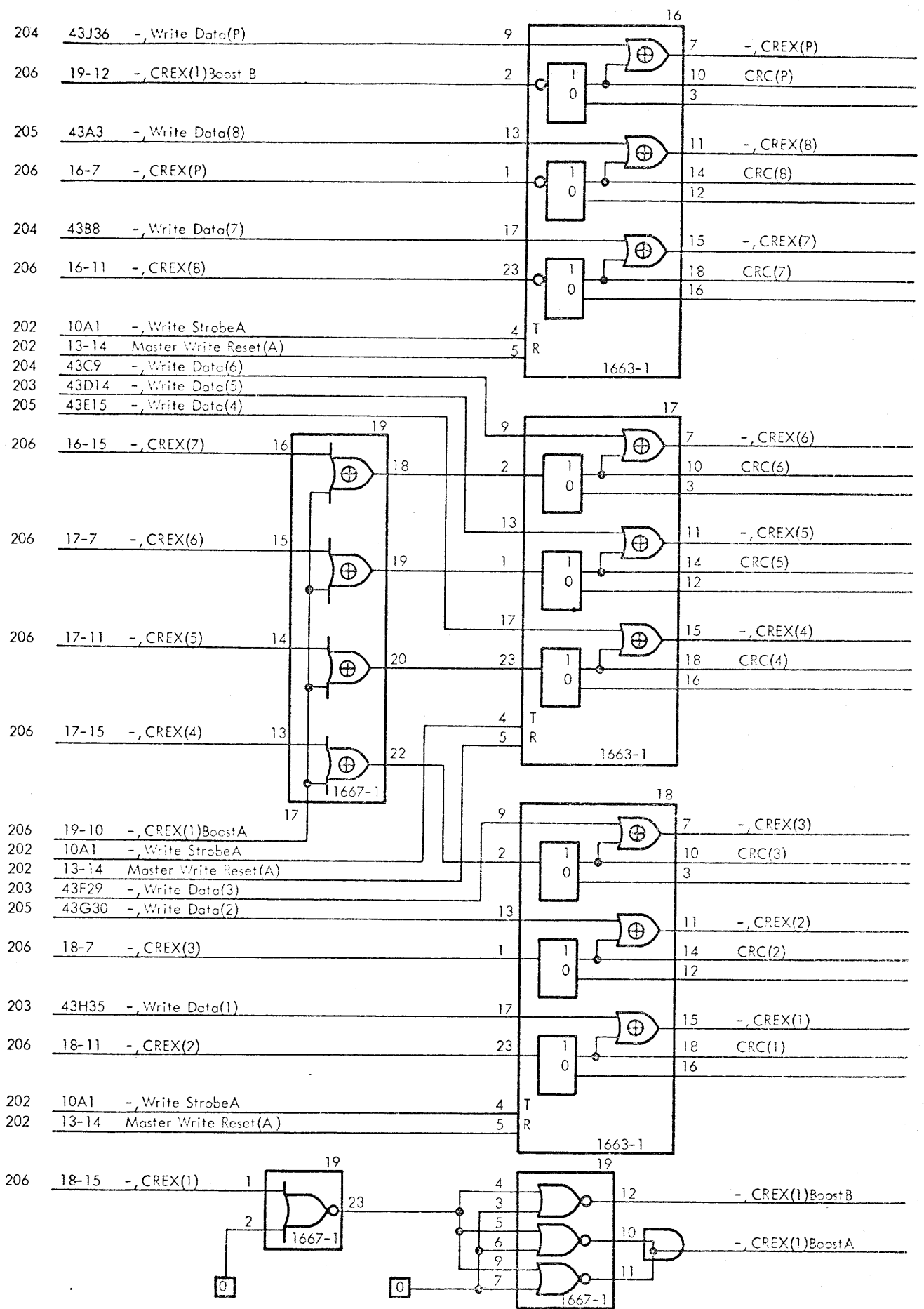

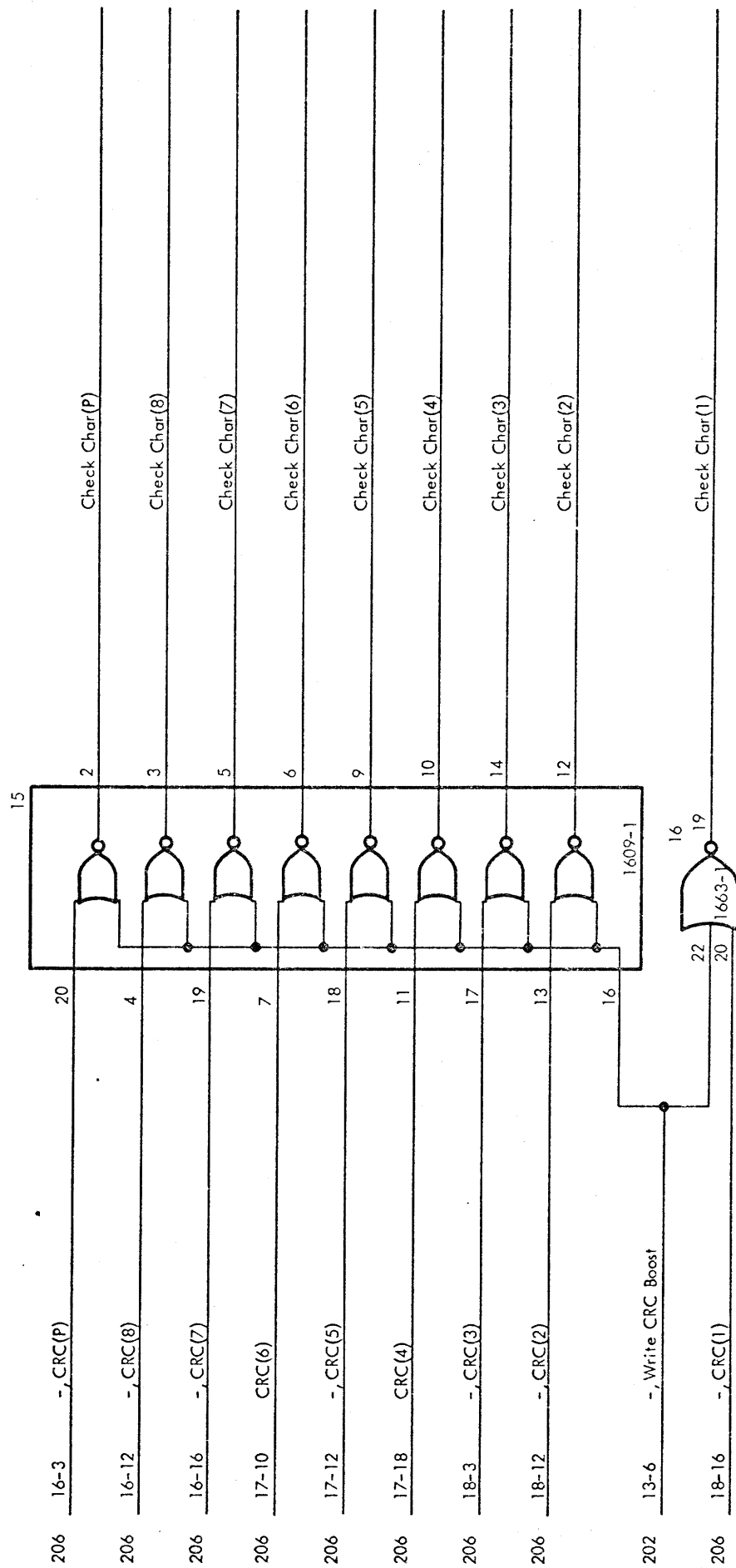

READ AMPLIFIERS AND DESKEW CIRCUITS

Logic Diagram

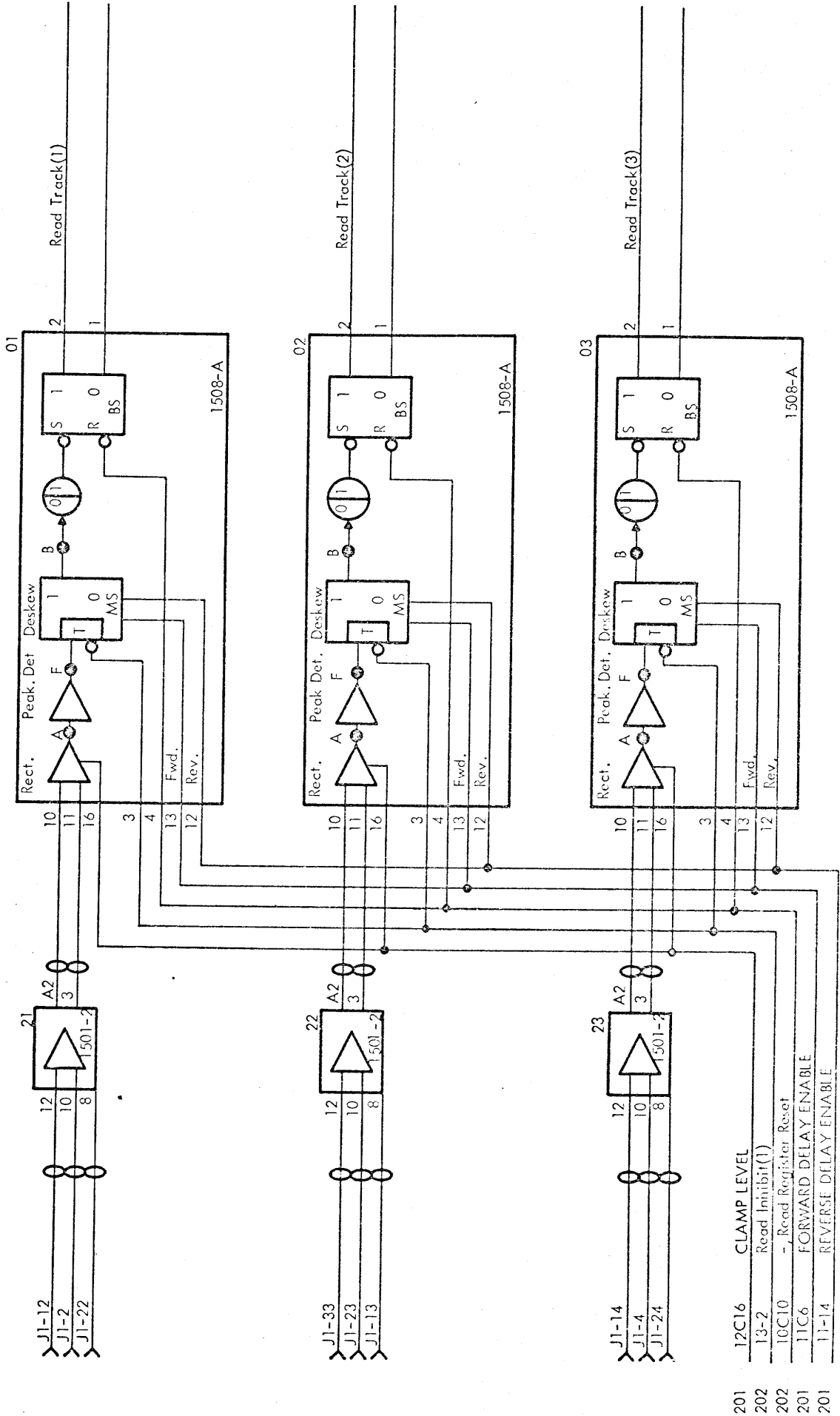

READ AMPLIFIERS AND DESKEW CIRCUITS

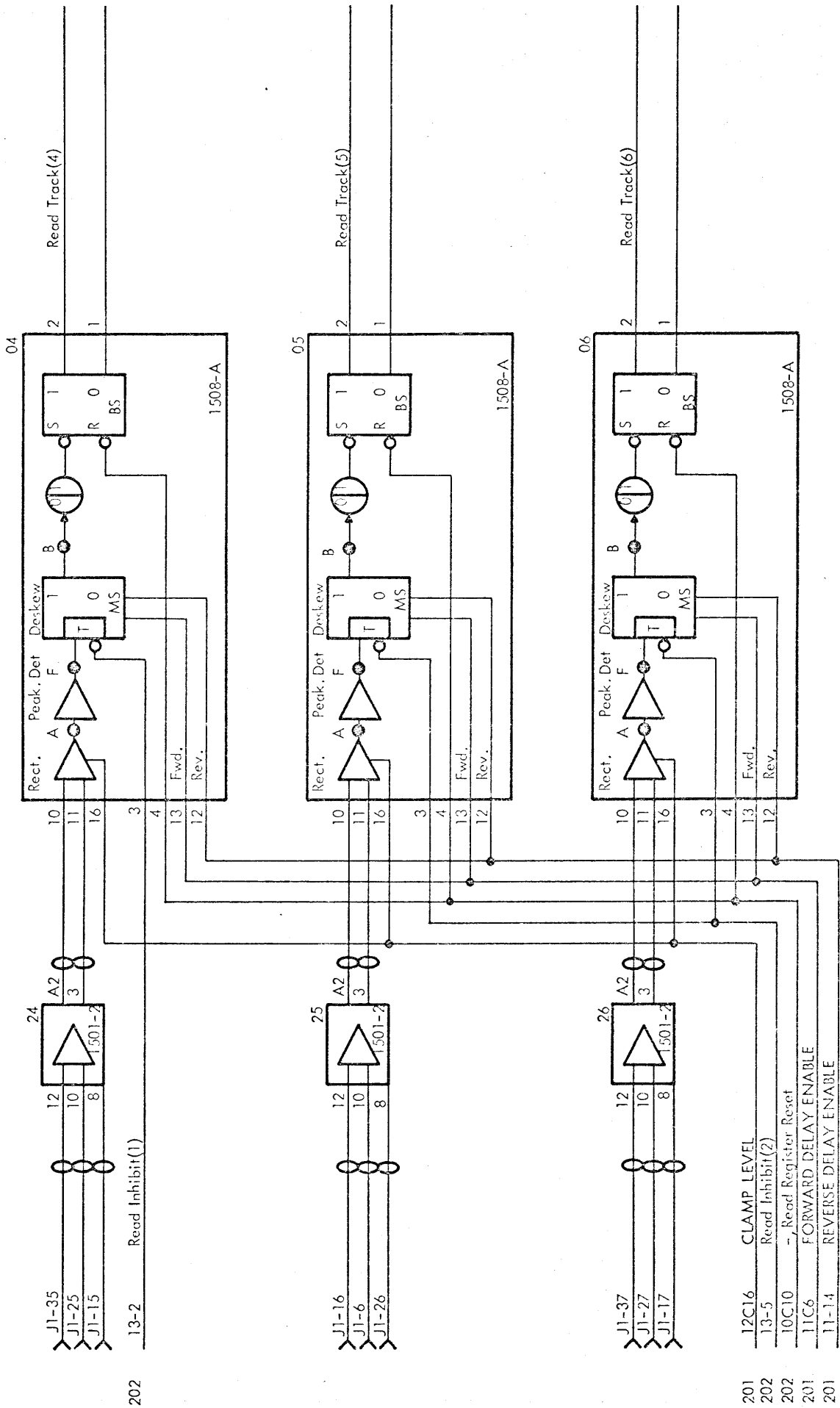

202

201  
202  
202  
201  
201



READ AMPLIFIERS AND DESKEW CIRCUITS

Logic Diagram

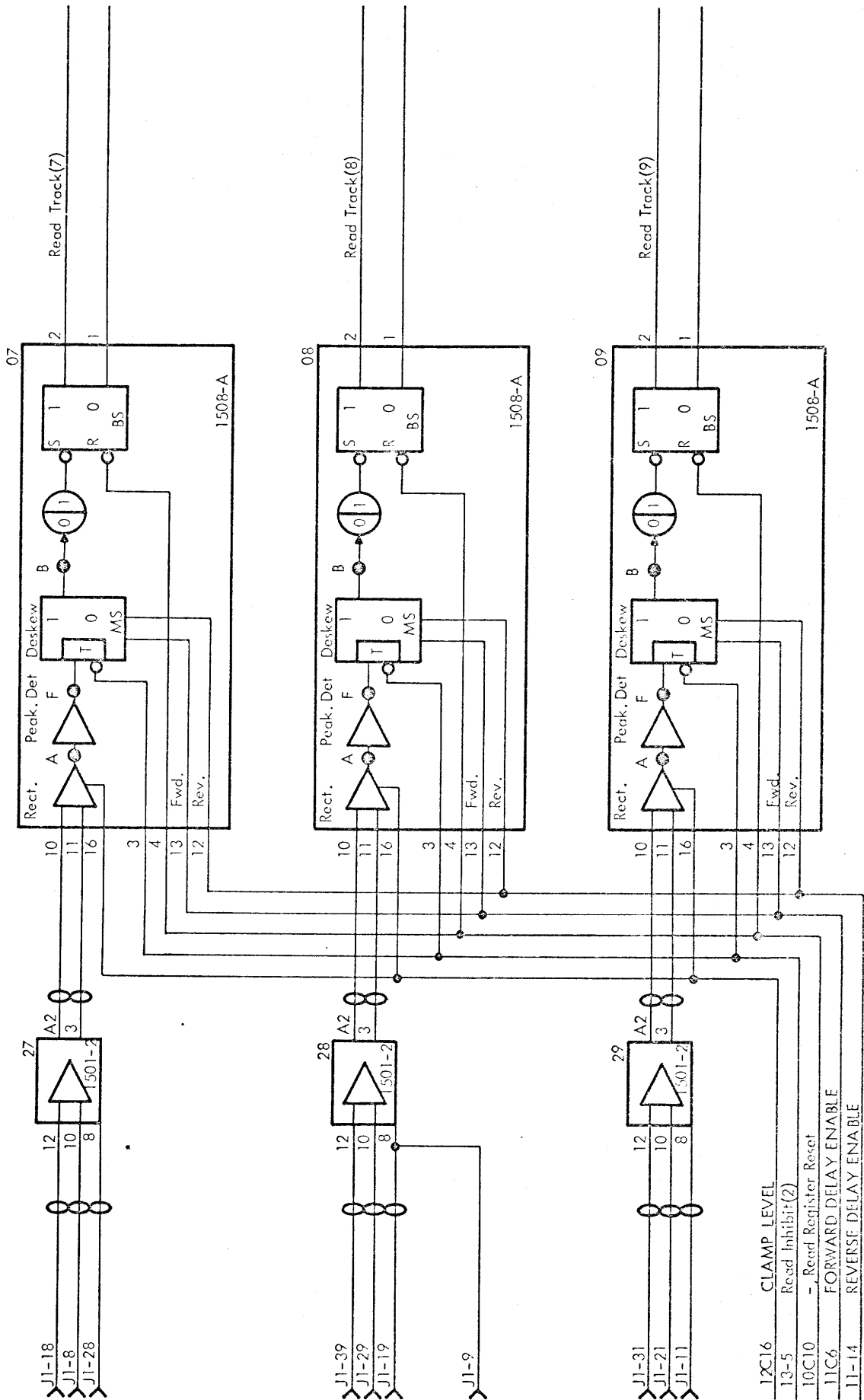

201  
202  
202  
201  
201

140569J0G 010570HA 21071000 MTC 170870 J0G V12347

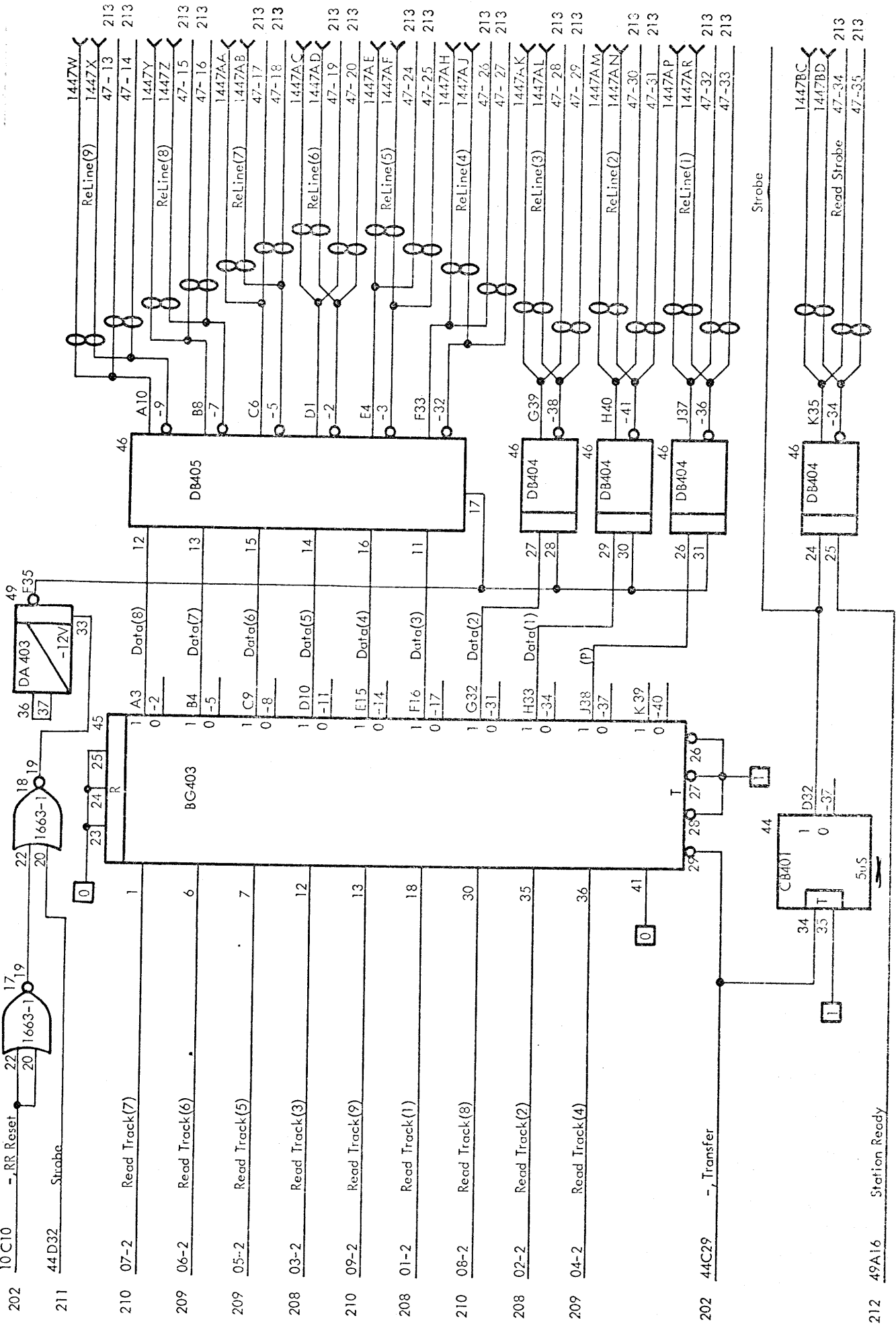

RC4000

READ BUFFER AND TRANSMITTERS

MTC-211

V 13576

Logic Diagram

CONTROL SIGNAL TRANSMITTERS AND LEVEL CONVERTERS

Logic Diagram

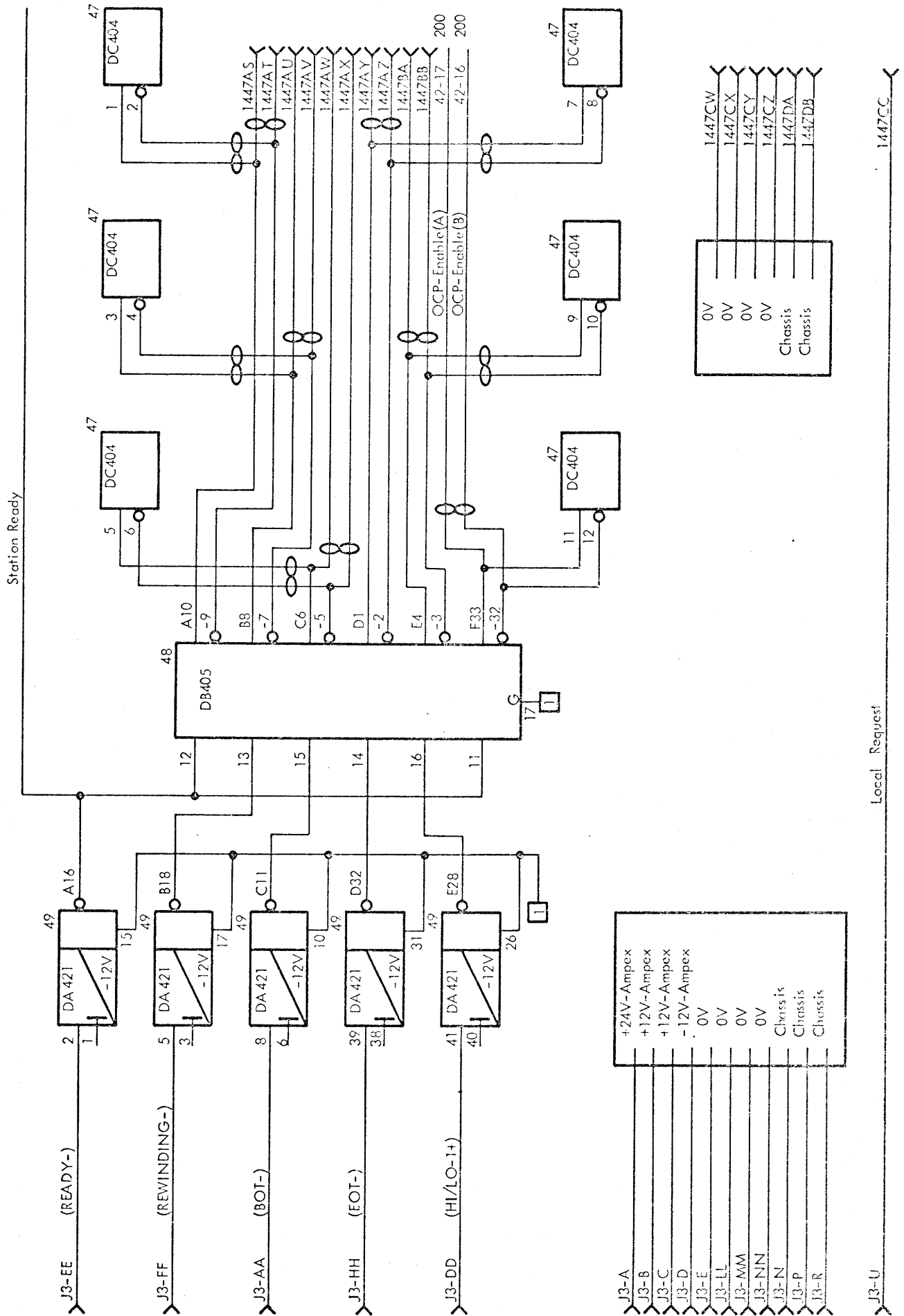

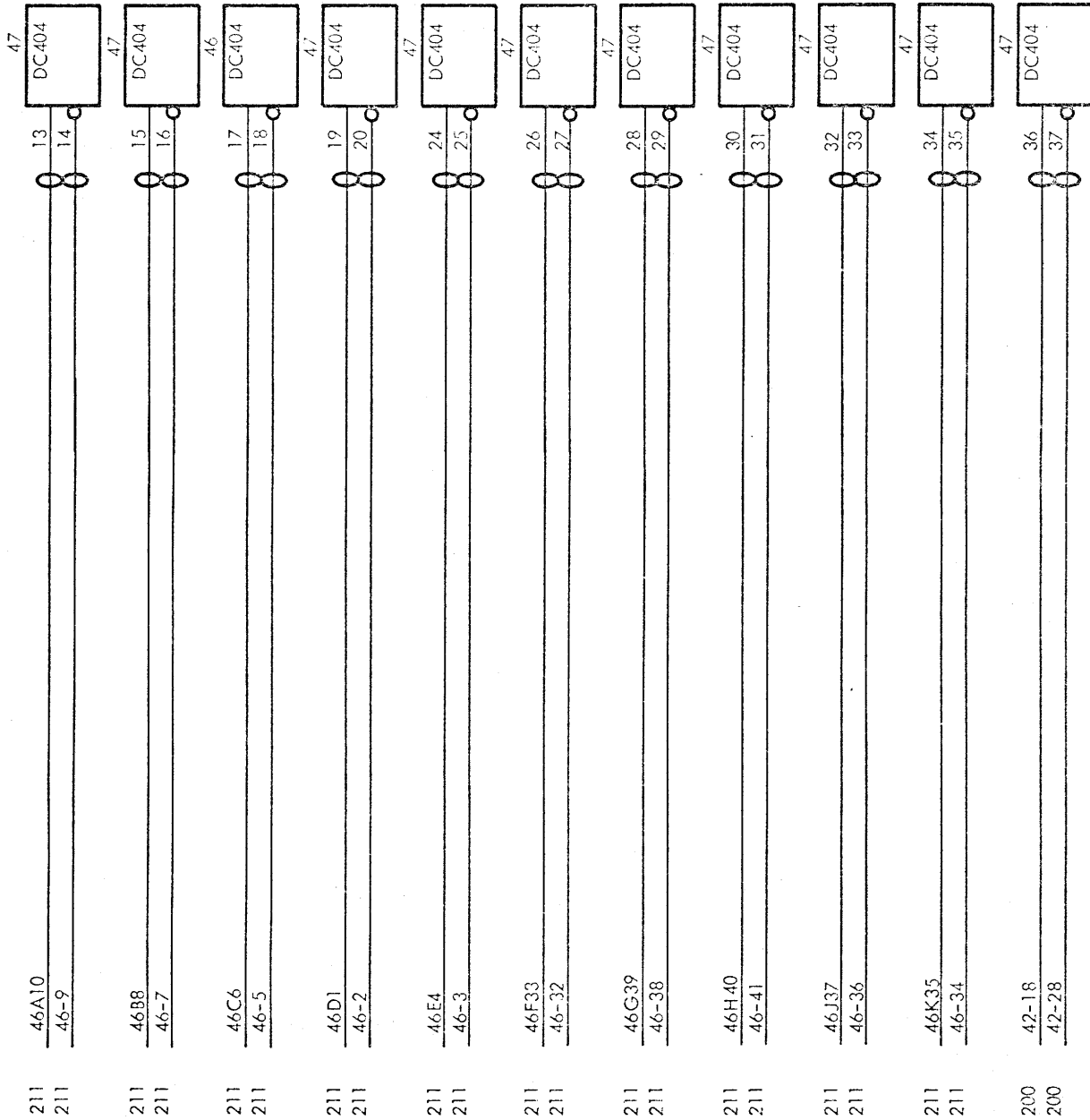

RC4000

V12349

TRANSMISSION LINE TERMINATION CIRCUITS

Logic Diagram

MTC-213

AIR FORCE CENTRALEN  
 Design No. 120669JQG  
 Part No. 010570HA  
 Rev. 21678 HC  
 Date 12-10-64  
 V12350  
 Downloaded by: [illegible]  
 Date: [illegible]

FRONT VIEW

49	Level Converter, DA 421 0853-5
48	Transmitter, DB404, DB405 0894-1
47	Terminator, DC404 0899-1
46	Transmitter, DB404, DB405 0894-1
45	Buffer Register, BG403 0854-1
44	Monostables, CB401 0871-1/11
43	Receivers, DC405 0897-2
42	Receivers, DC405 0897-2
41	Level Converters, DA 416 0856-7

19	CRC-Inverter 1667-1	39
18	3 x CRC Reg. 1663-1	38
17		37
16		36
15	CRC-Gates 1609-2	35
14	Write Power 1688A-2	34
13	Boosters 1609-2	33
12	Clamp Level 1682-1	32
11	Test Generator 1509A-5	31
10	OR-Gate 1698-1	30
09		29
08		28
07		27
06	9x Read Deskew 1508A-8	26
05		25
04	9x Read Amplifier 1501-1	24
03		23
02		22
01		21
		20
		19
		18
		17
		16
		15
		14
		13
		12
		11
		10
		09
		08
		07
		06
		05
		04
		03
		02
		01

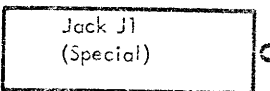
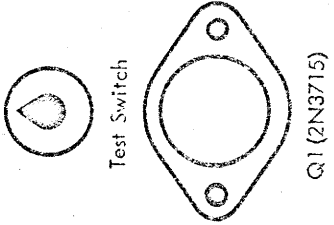
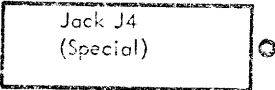
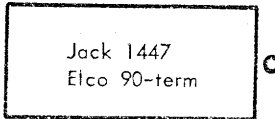
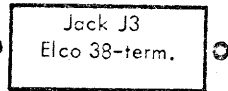

RC4000  
V13221

CARD POSITIONS, TME 301

Logic Diagram

MTC-214

MTC 402

PCBA Position List

<u>Pos.</u>	<u>PCBA</u>
MTC 001	RC0900-1/3
MTC 002	RC0911-1/x
MTC 003	RC0837-1
MTC 004	RC0835-1
MTC 005	RC0834-1
MTC 006	RC0834-1
MTC 007	RC0838-1
MTC 008	RC0834-1
MTC 009	RC0834-1
MTC 010	RC0835-1
MTC 011	RC0838-1
MTC 012	RC0852-1
MTC 013	RC0836-1
MTC 014	RC0836-1
MTC 015	RC0839-1
MTC 016	RC0884-1
MTC 017	RC0834-1
MTC 018	RC0839-1
MTC 019	RC0834-1
MTC 020	RC0834-1
MTC 021	RC0835-1
MTC 022	RC0834-1
MTC 023	RC0847-1
MTC 024	RC0835-1
MTC 025	RC0839-1
MTC 026	RC0834-1
MTC 027	RC0847-1
MTC 028	RC0854-1
MTC 029	RC0847-1
MTC 030	RC0847-1
MTC 031	RC0834-1
MTC 032	RC0847-1

Tegn nr V23316  
dato 210972

Pos.	PCBA
MTC 033	RC0854-1
MTC 034	RC0847-1
MTC 035	RC0834-1
MTC 036	RC0847-1
MTC 037	RC0834-1
MTC 038	RC0846-1
MTC 039	RC0845-1
MTC 040	RC0845-1
MTC 041	RC0845-1
MTC 042	RC0845-1
MTC 043	RC0845-1
MTC 044	RC0845-1
MTC 045	RC0845-1
MTC 046	RC0845-1
MTC 047	RC0897-1
MTC 048	RC0897-1
MTC 049	RC0839-1
MTC 050	RC0839-1
MTC 051	RC0894-1
MTC 052	RC0835-1
MTC 053	RC0835-1
MTC 054	RC0909-1/19
MTC 055	RC0898-1
MTC 056	RC0897-1
MTC 057	RC0898-1
MTC 058	RC0894-1
MTC 059	RC0862-1
MTC 060	RC0862-1
MTC 061	RC0862-1
MTC 062	RC0835-1
MTC 063	RC0894-1
MTC 064	RC0836-1
MTC 065	RC0898-1
MTC 066	RC0901-1
MTC 067	RC0836-1

Pos.	PCBA
MTC 068	RC0855-1
MTC 069	RC0898-1
MTC 070	RC0844-1
MTC 071	RC0847-1
MTC 072	RC0894-1
MTC 073	RC0862-1
MTC 074	RC0862-1
MTC 075	RC0862-1
MTC 076	RC0847-1
MTC 077	RC0844-1
MTC 078	RC0847-1
MTC 080	RC0834-1
MTC 081	RC0899-1
MTC 087	RC0837-1
MTC 089	RC0860-2
MTC 090	RC0861-1
MTC 091	RC0897-1
MTC 092	RC0902-1
MTC 093	RC0888-1/2
MTC 094	RC0903-1/x
MTC 095	RC0871-1/8
MTC 097	RC0897-1
MTC 098	RC0897-1
MTC 099	RC0897-1
MTC 100	RC0839-1
MTC 101	RC0852-1
MTC 102	RC0888-1/1
MTC 103	RC0899-1



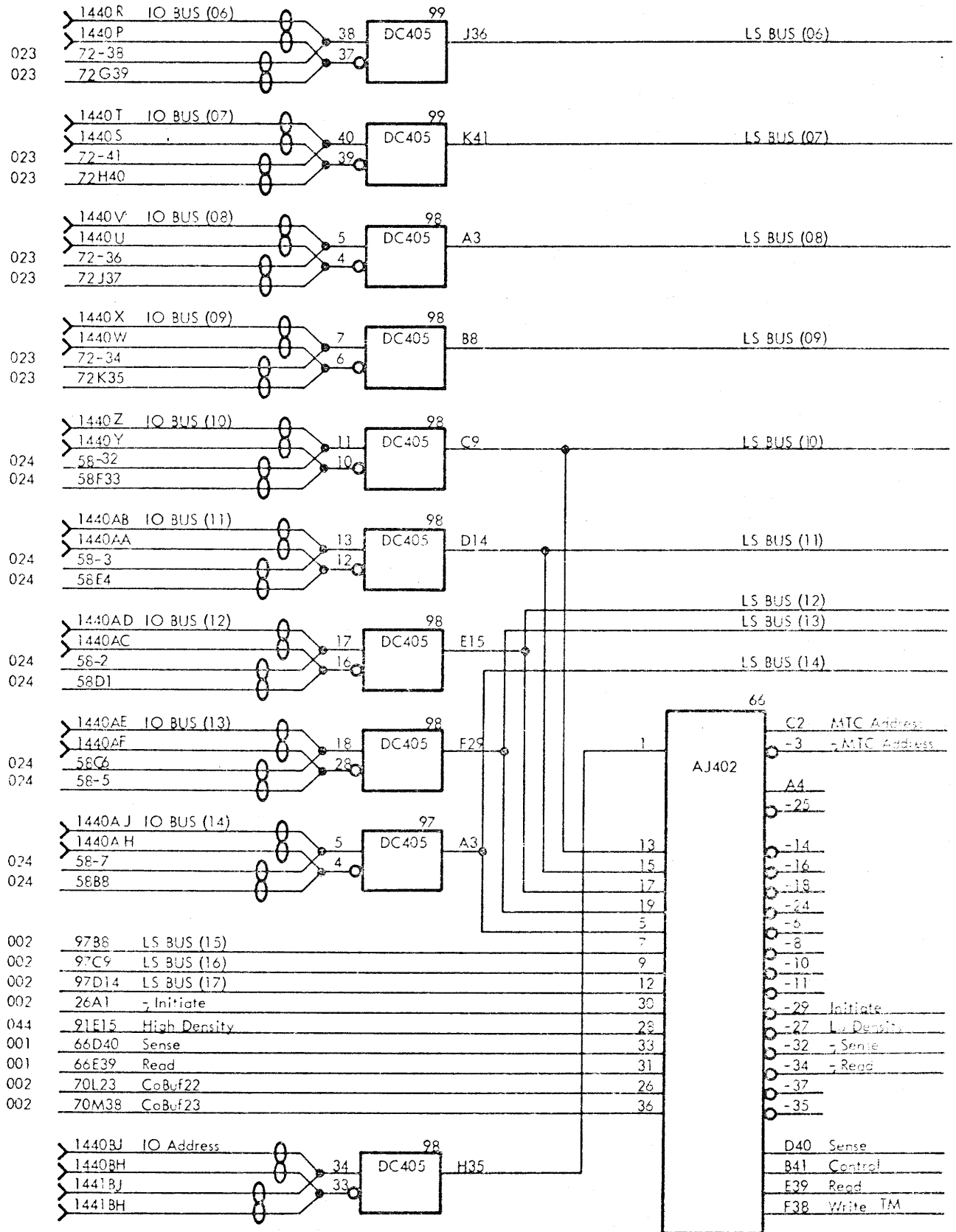

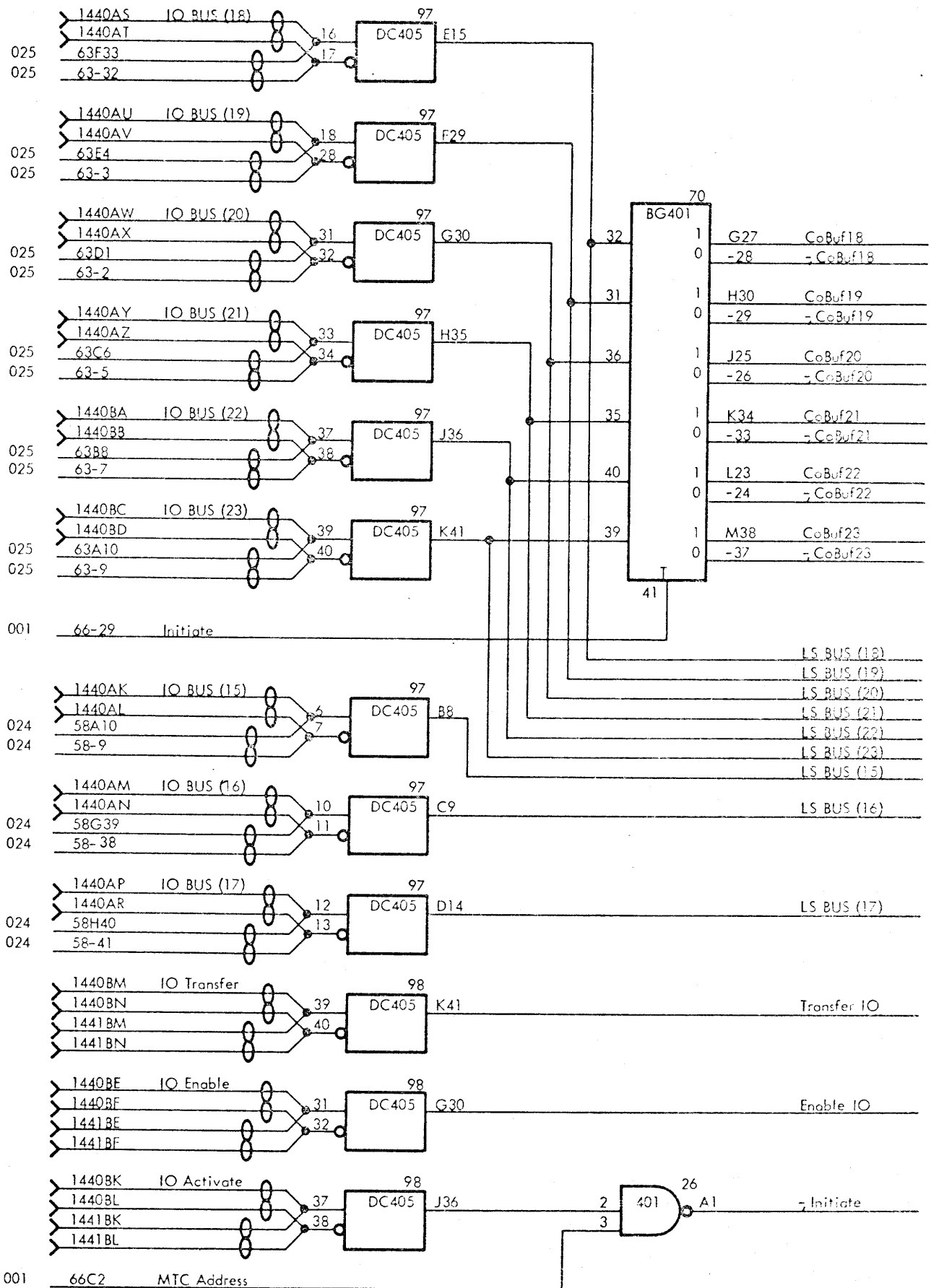

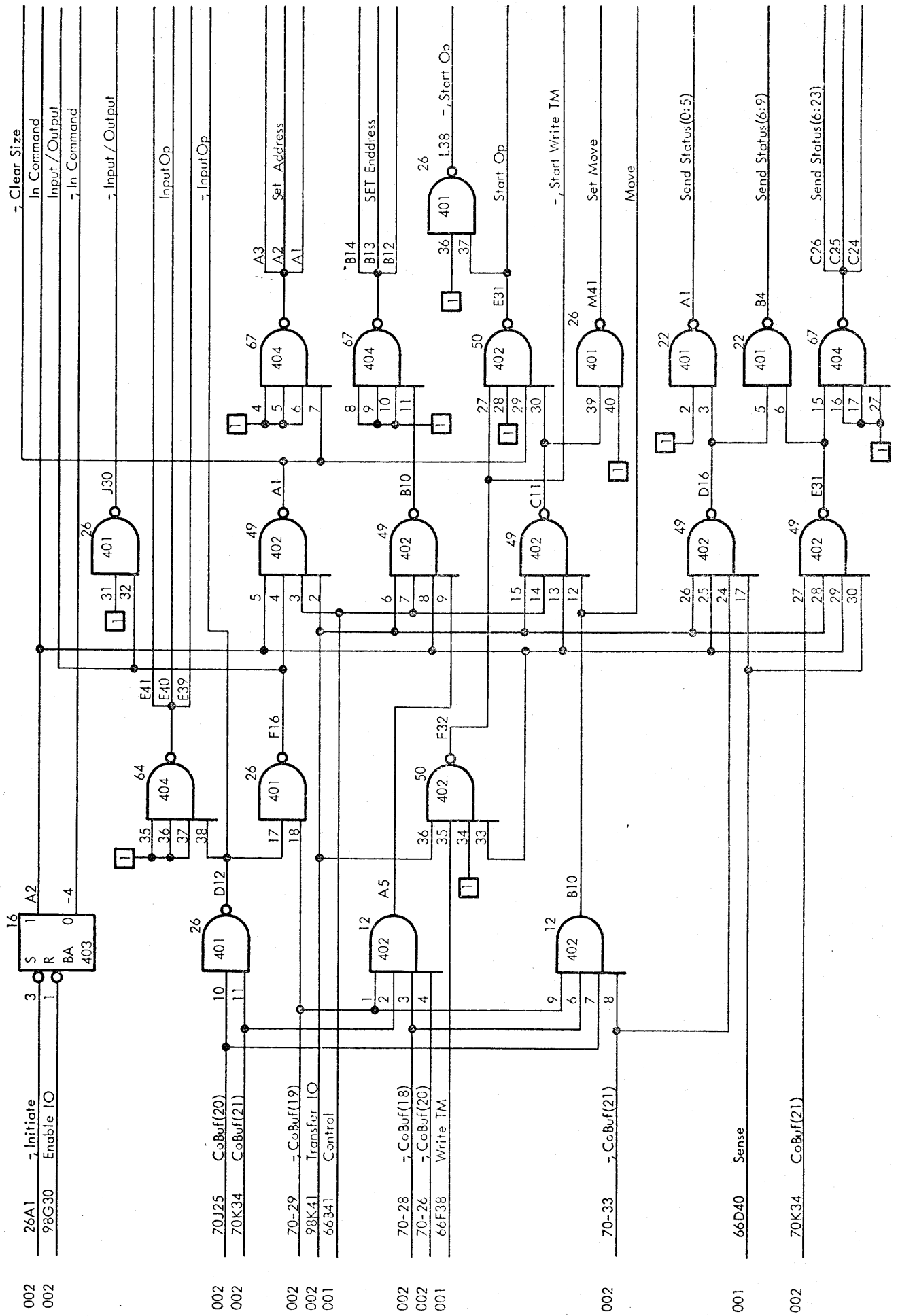

WRITE CONTROL CIRCUITS

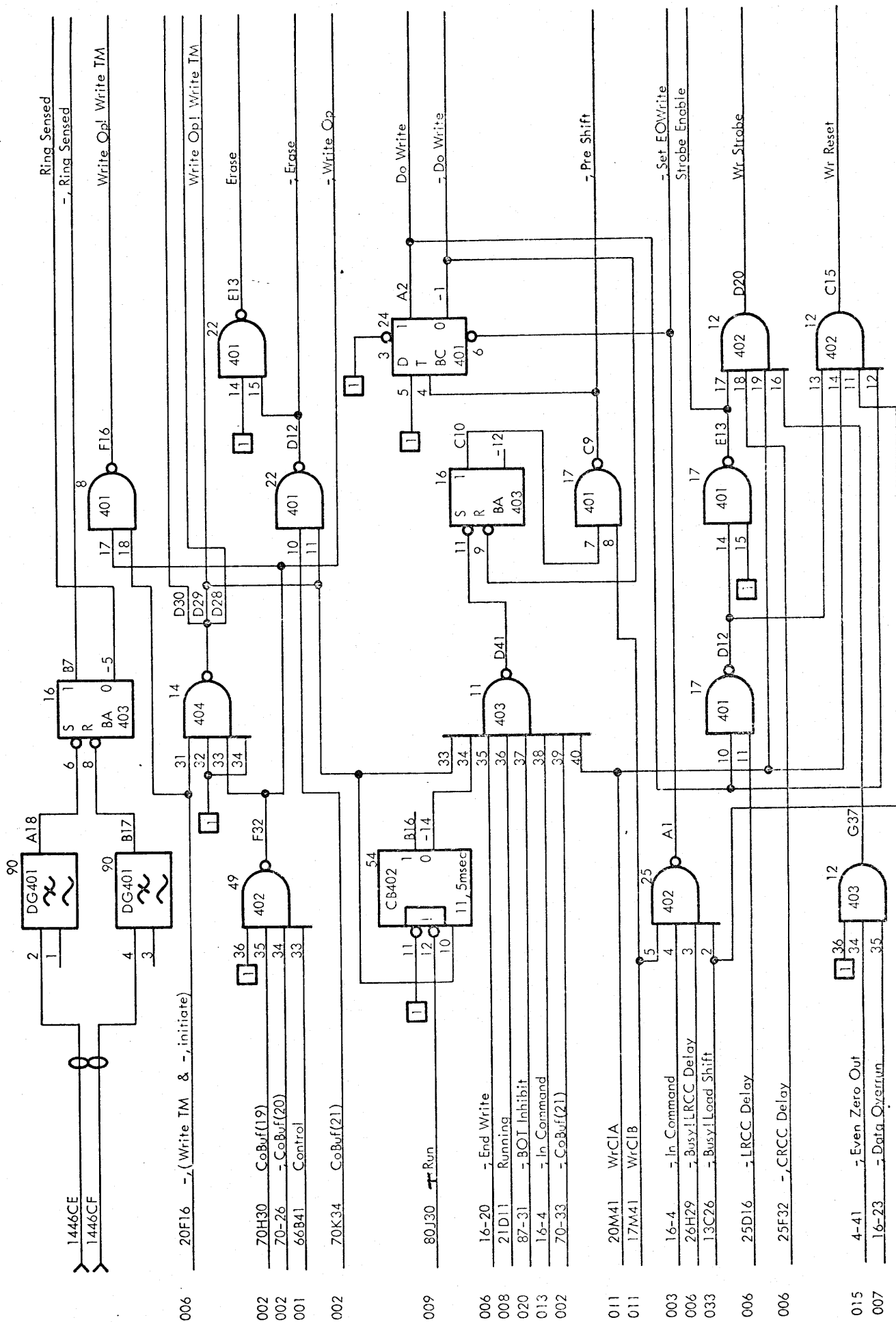

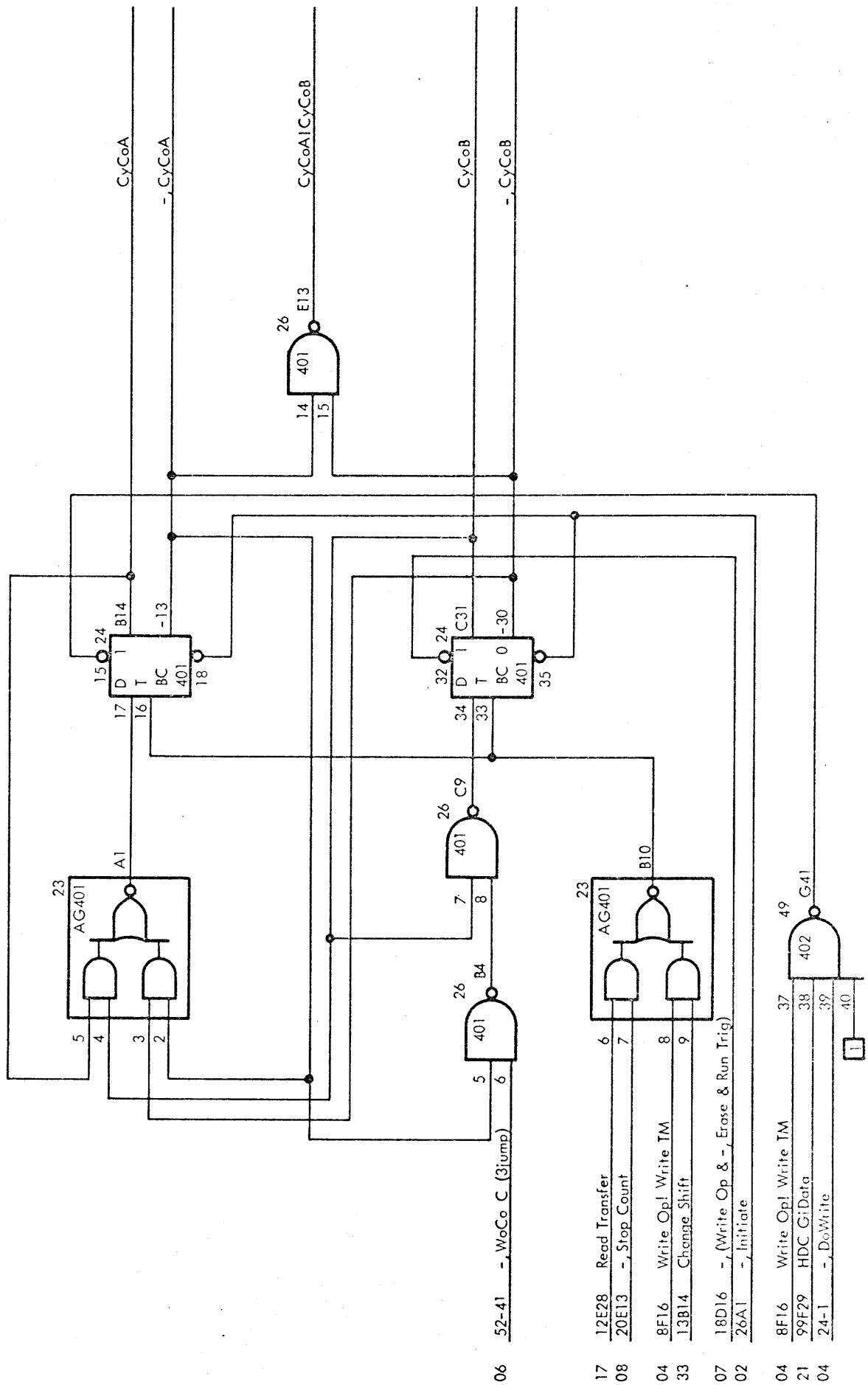

END BLOCK WORD COUNTER  
Logic Diagram

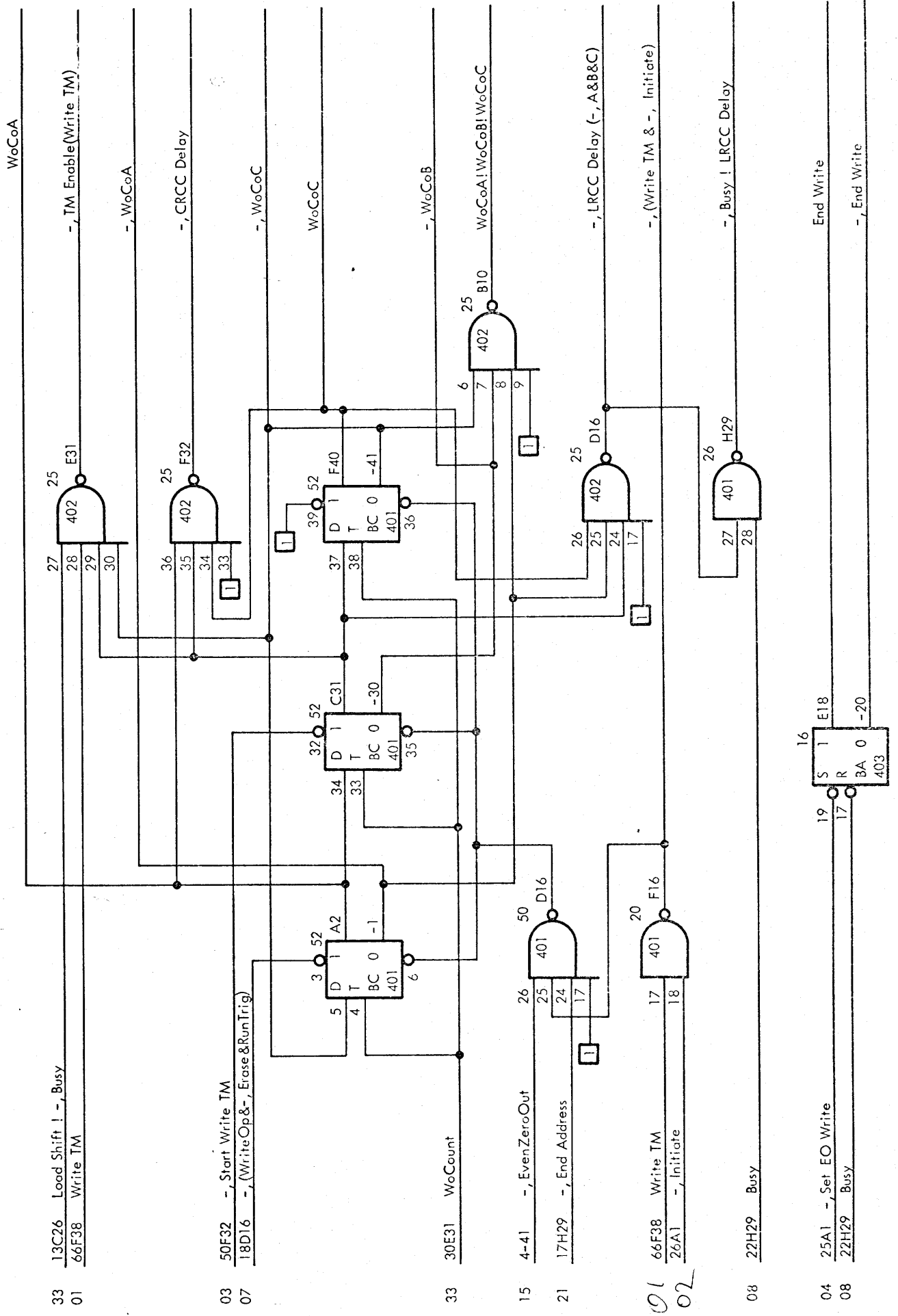

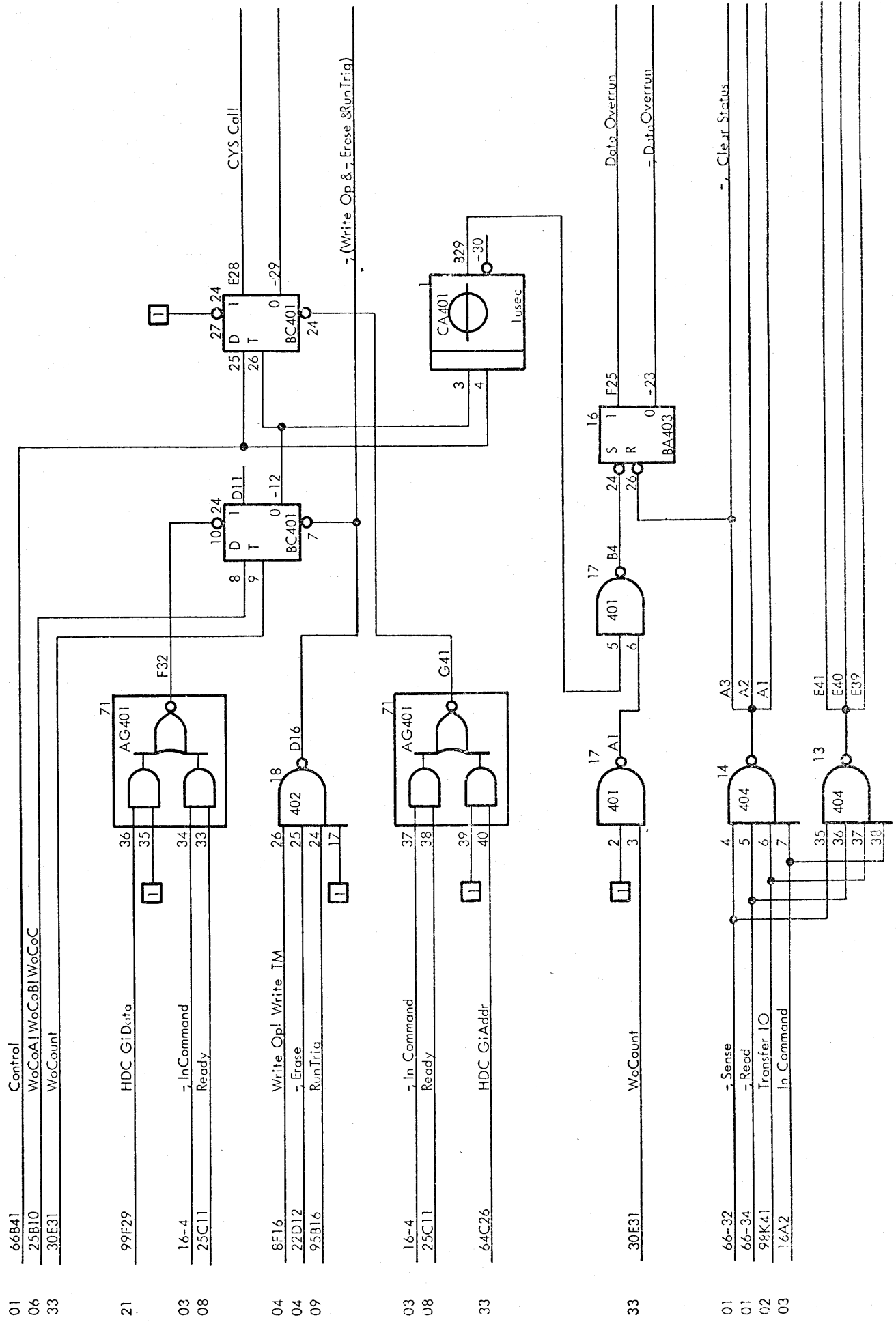

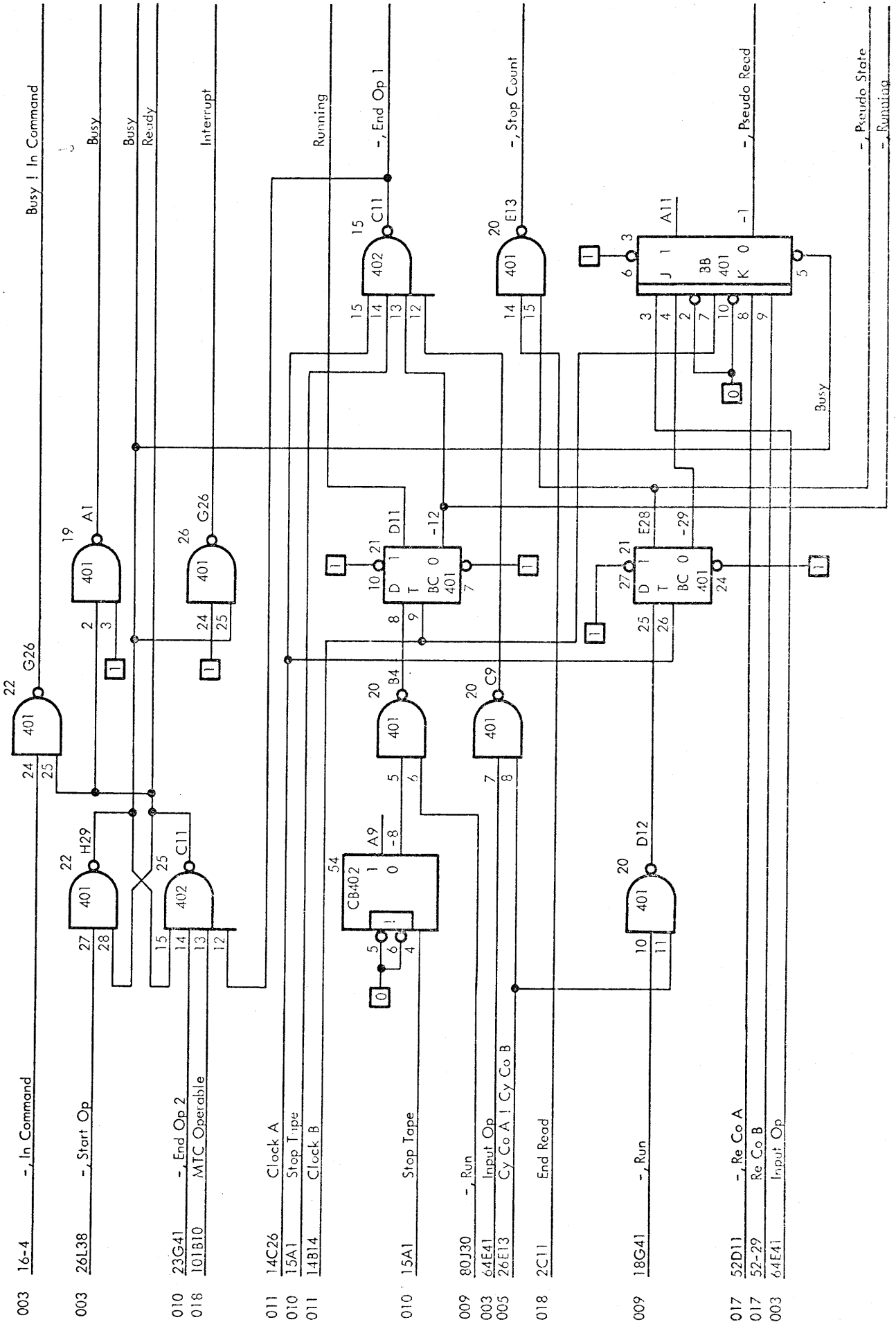



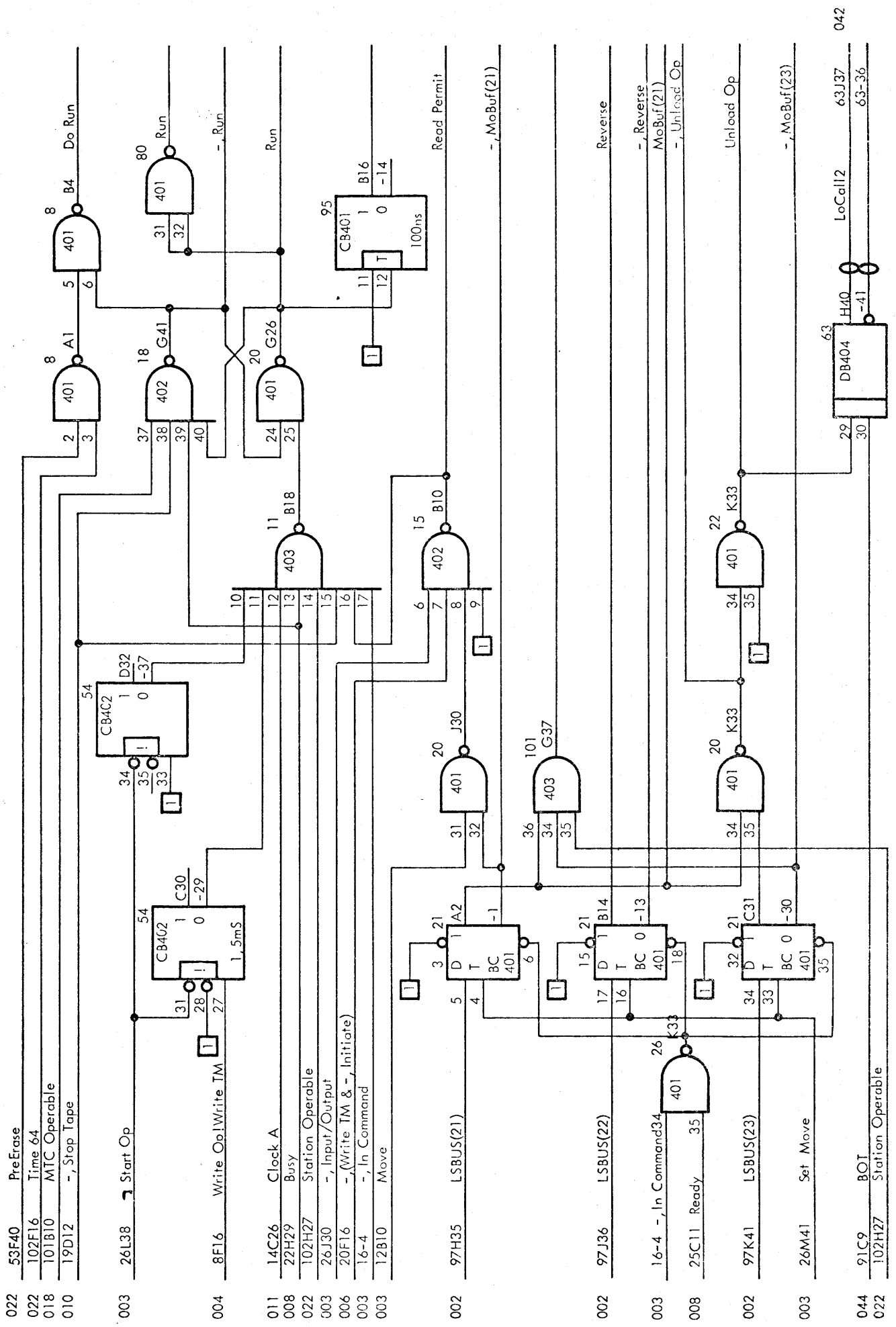

RUN STOP CIRCUITS AND END OP2

Logic Diagram

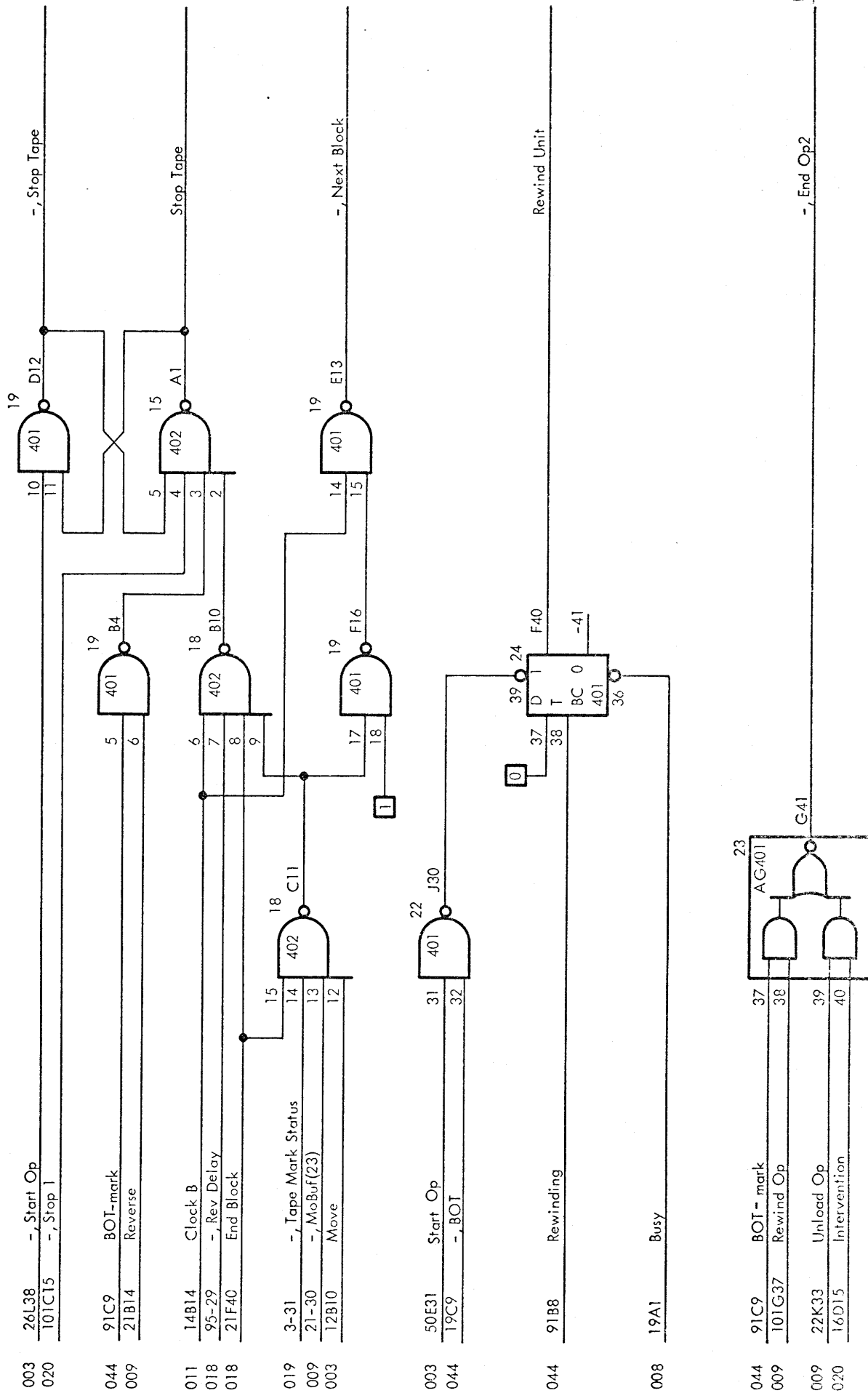

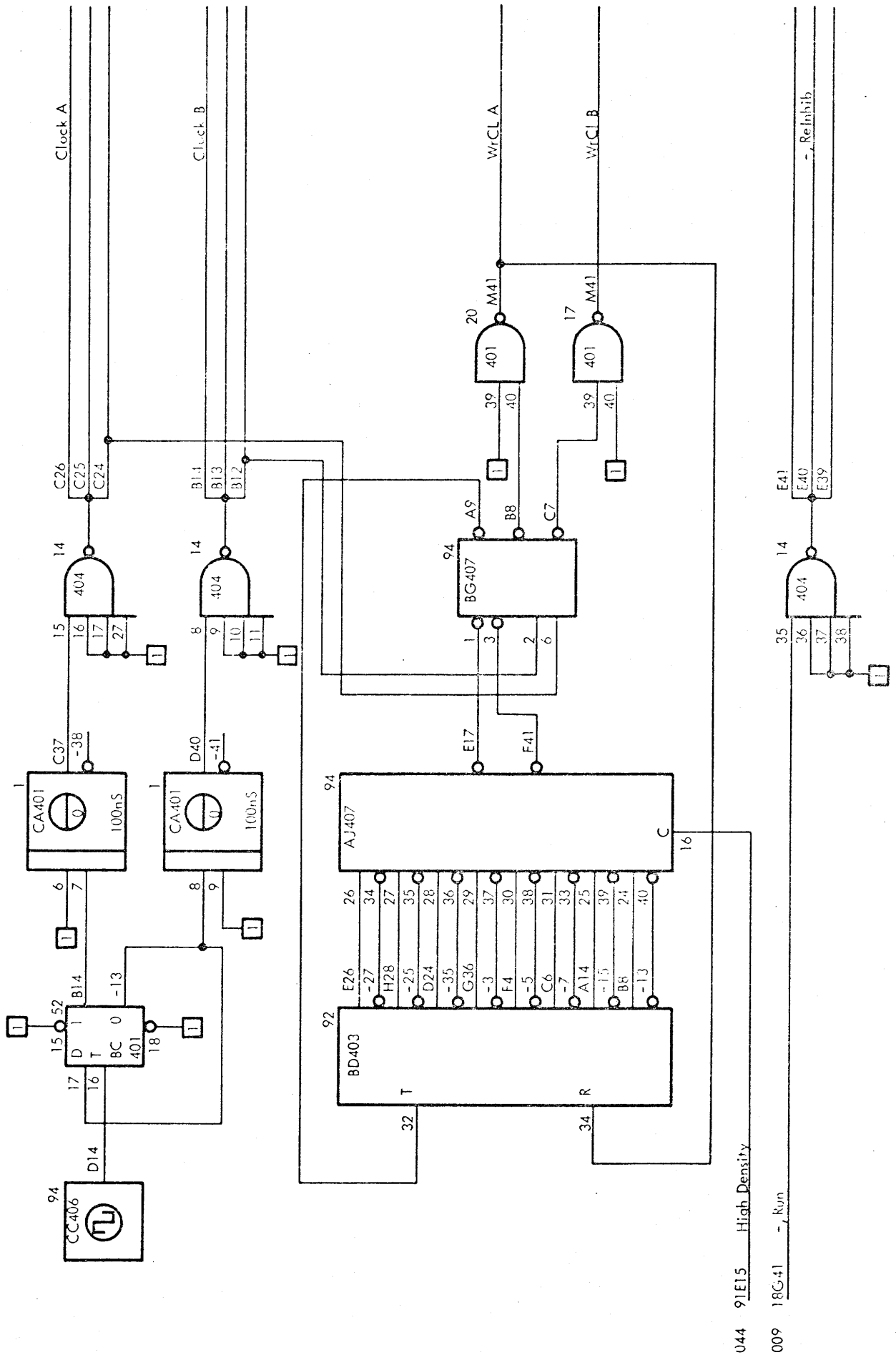

044 91E15 High Density

009 18C41 - Kun

- Refinib

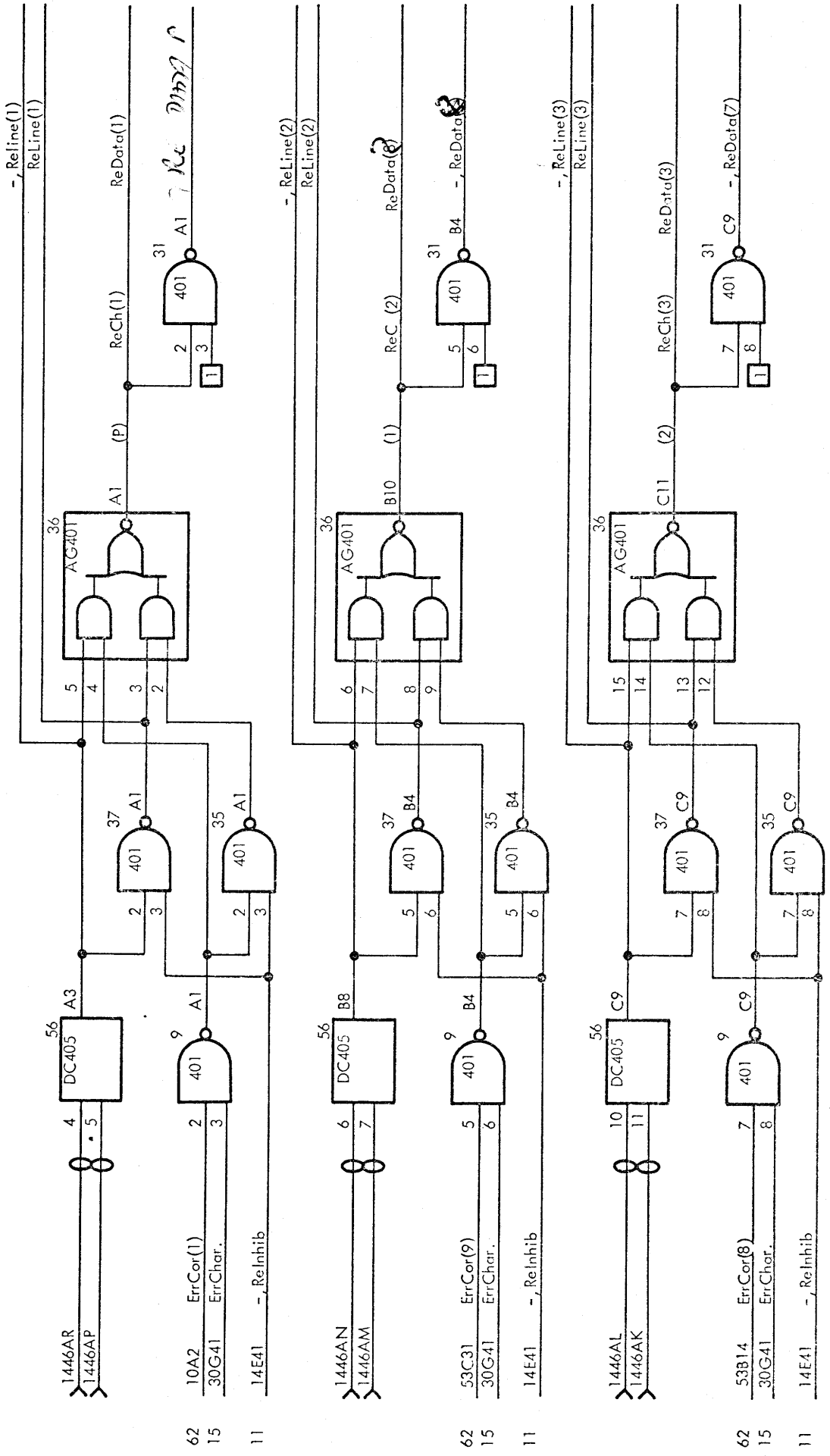

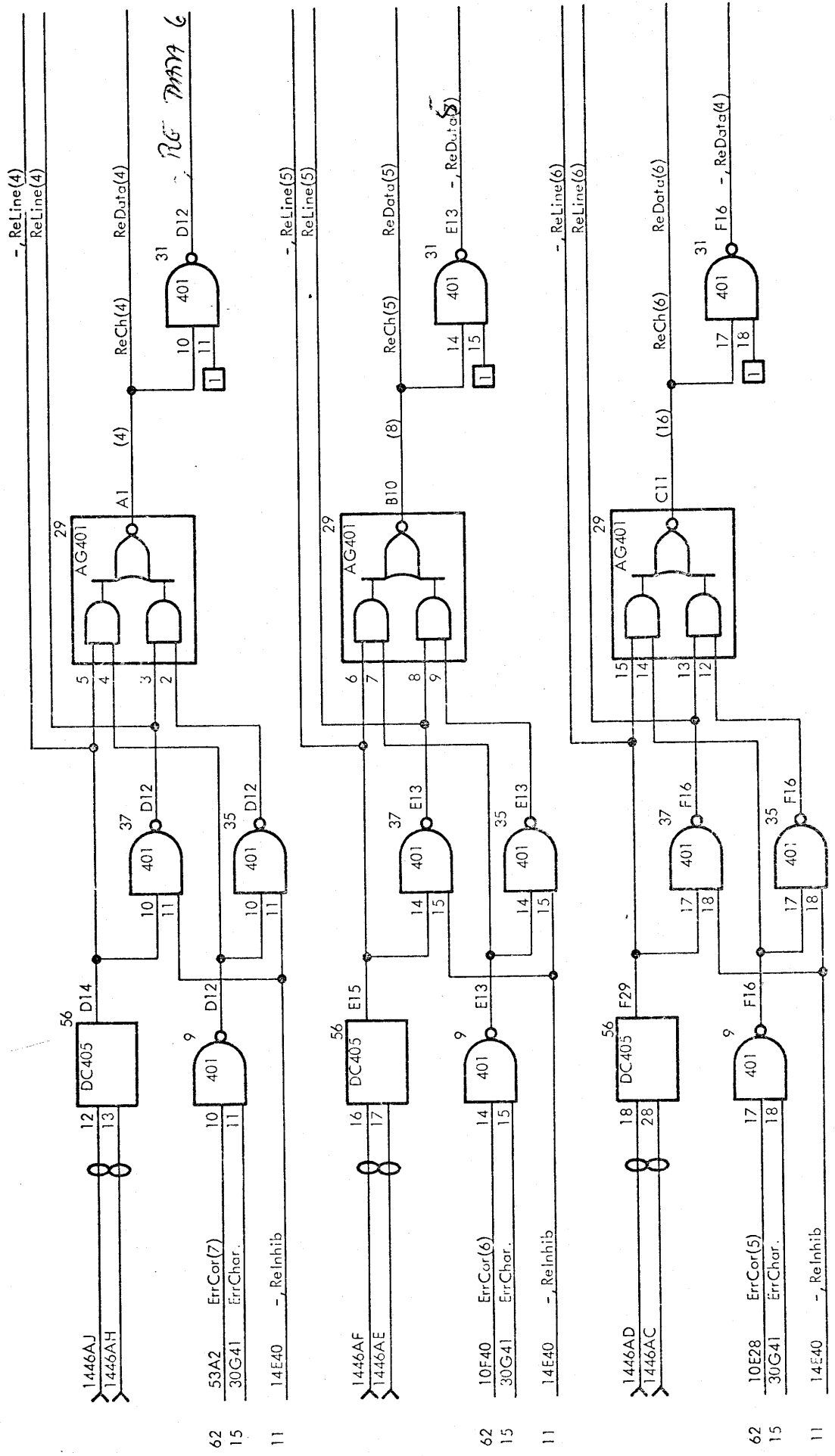

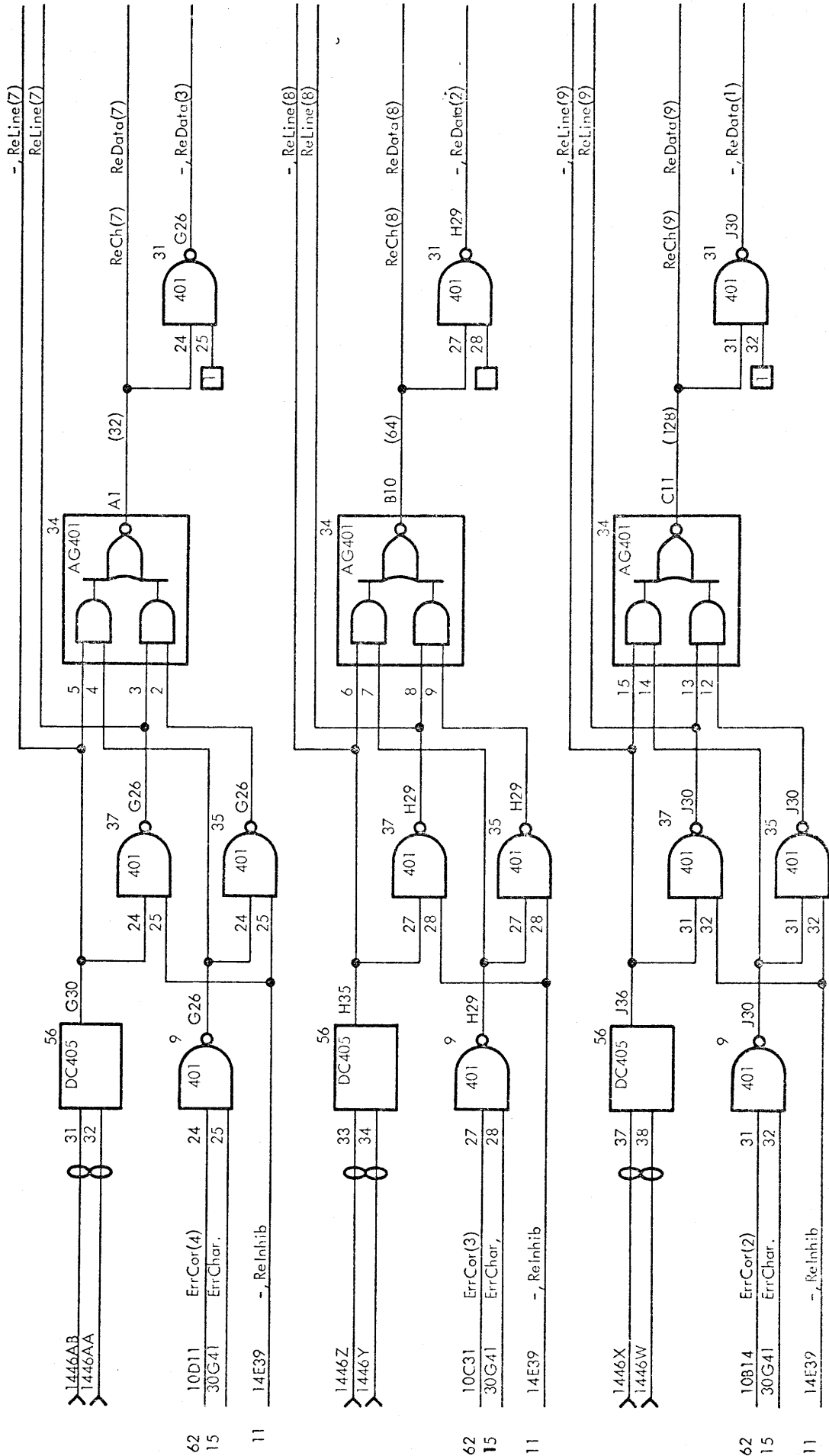

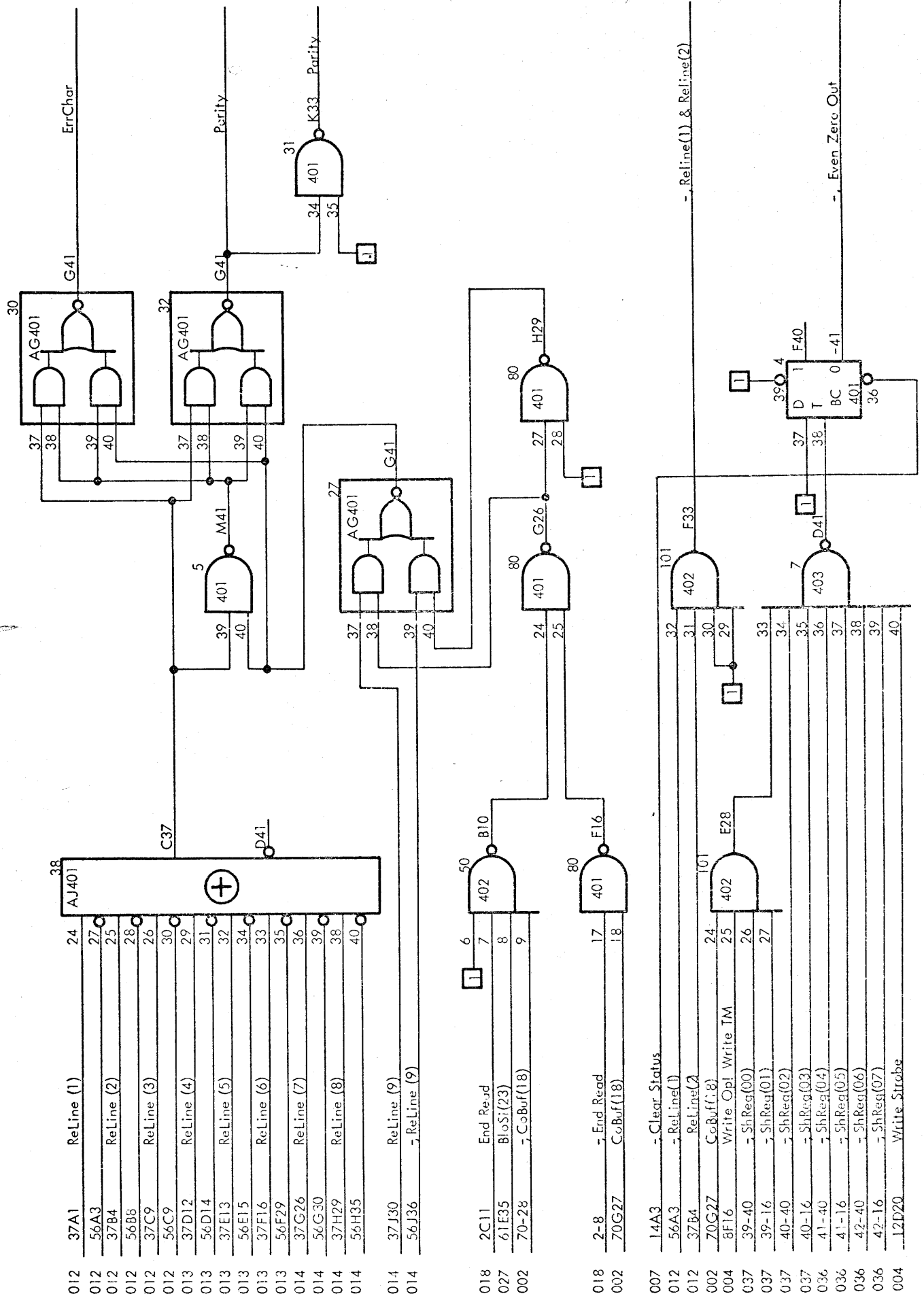

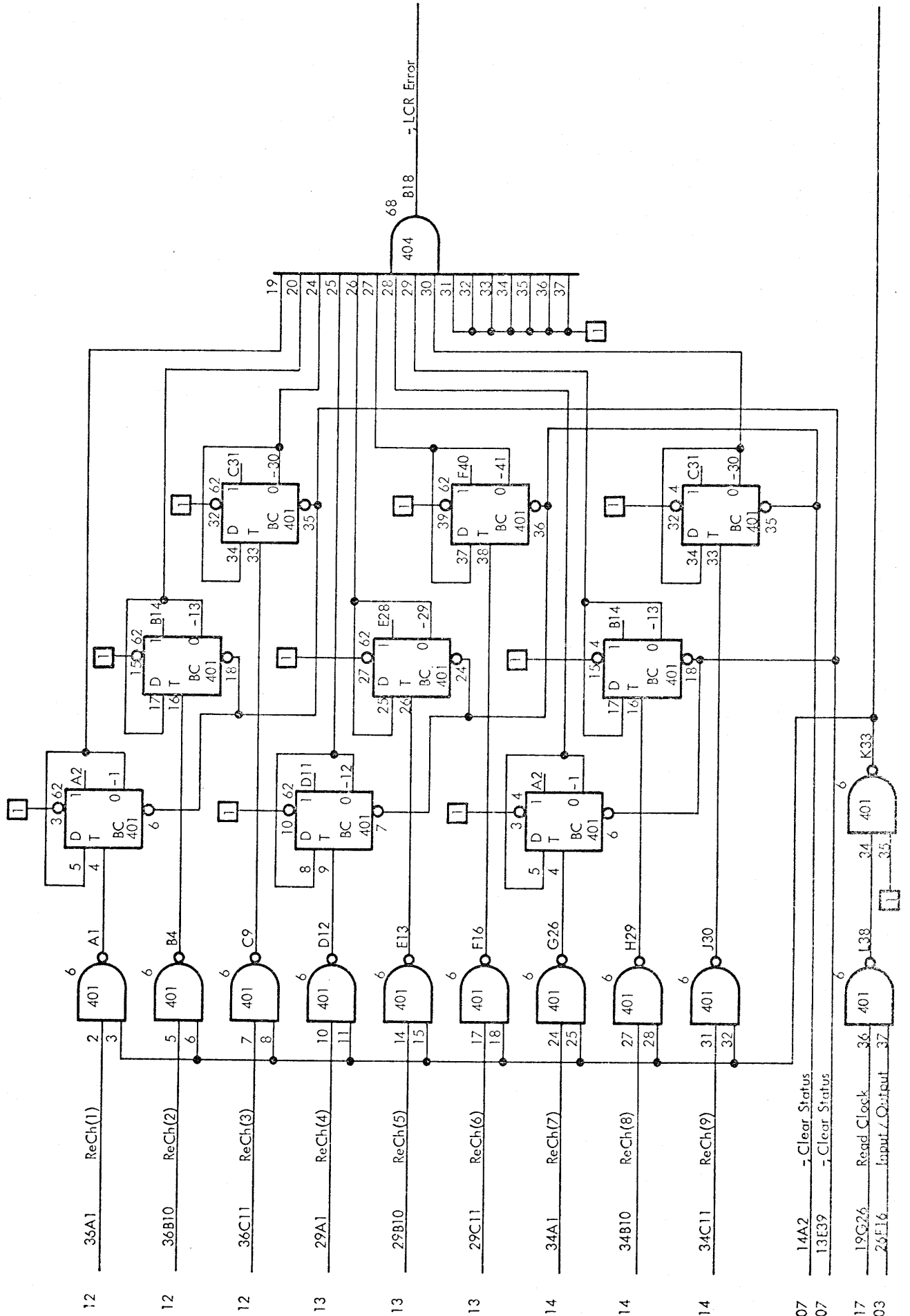



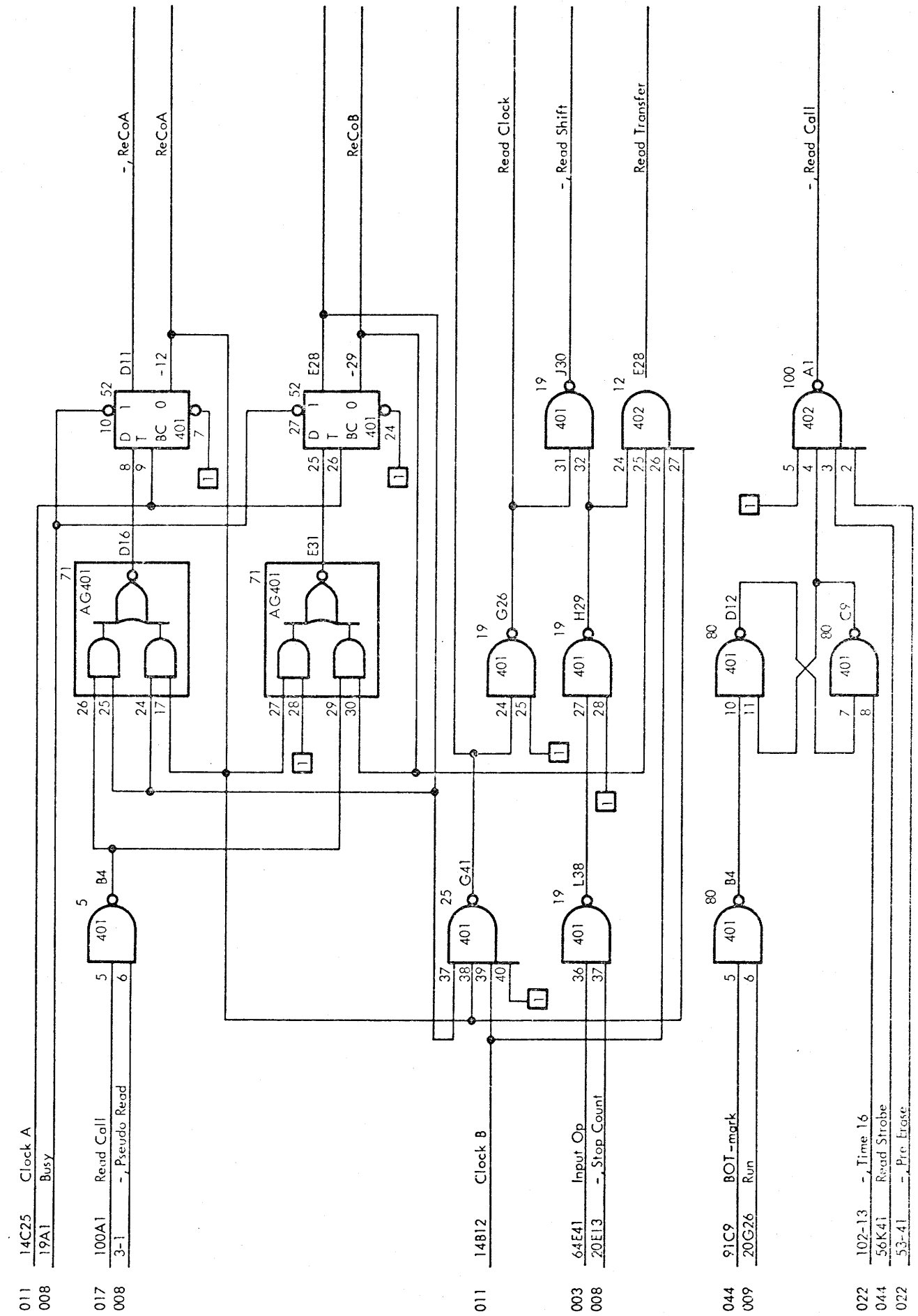

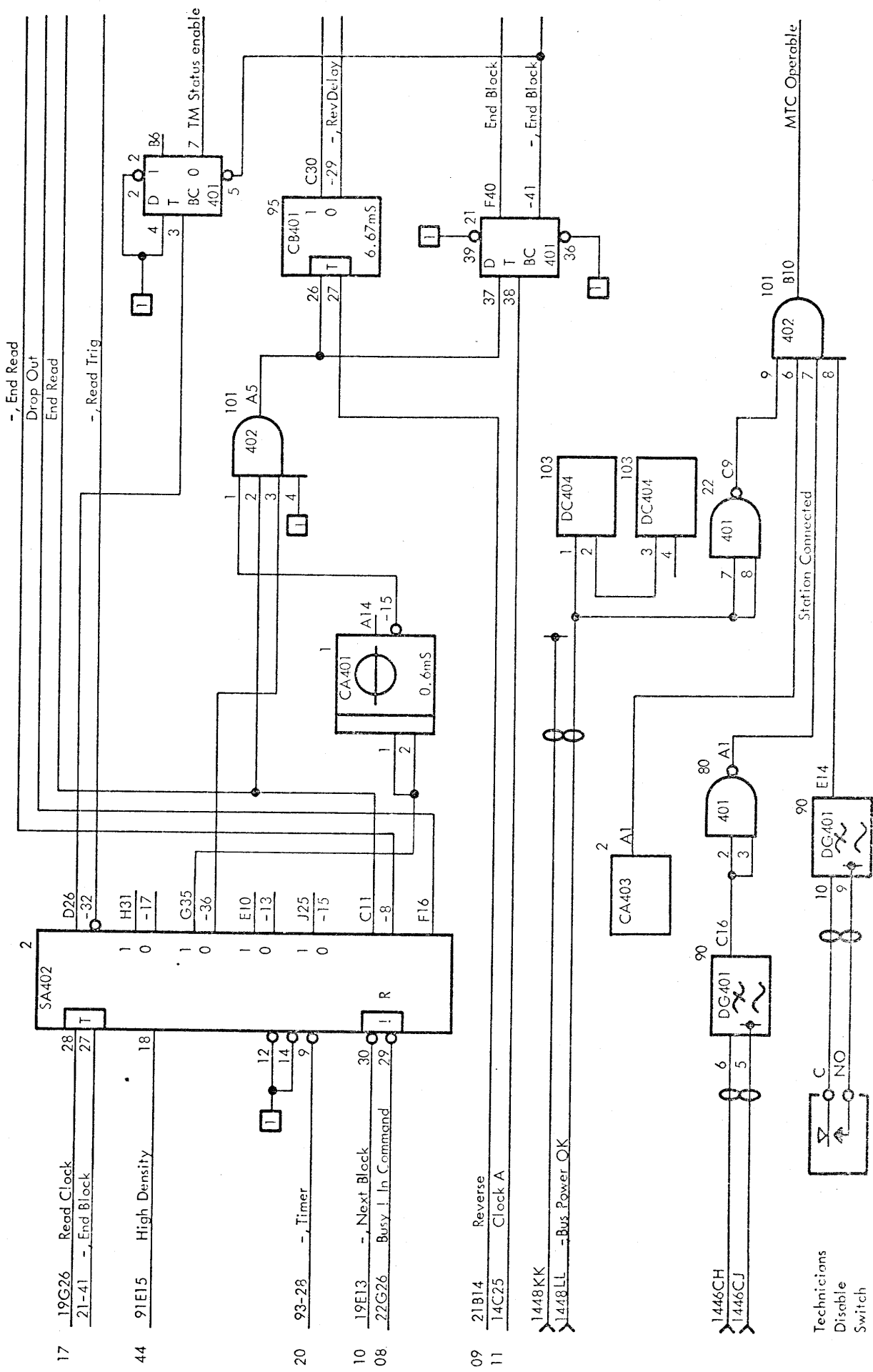

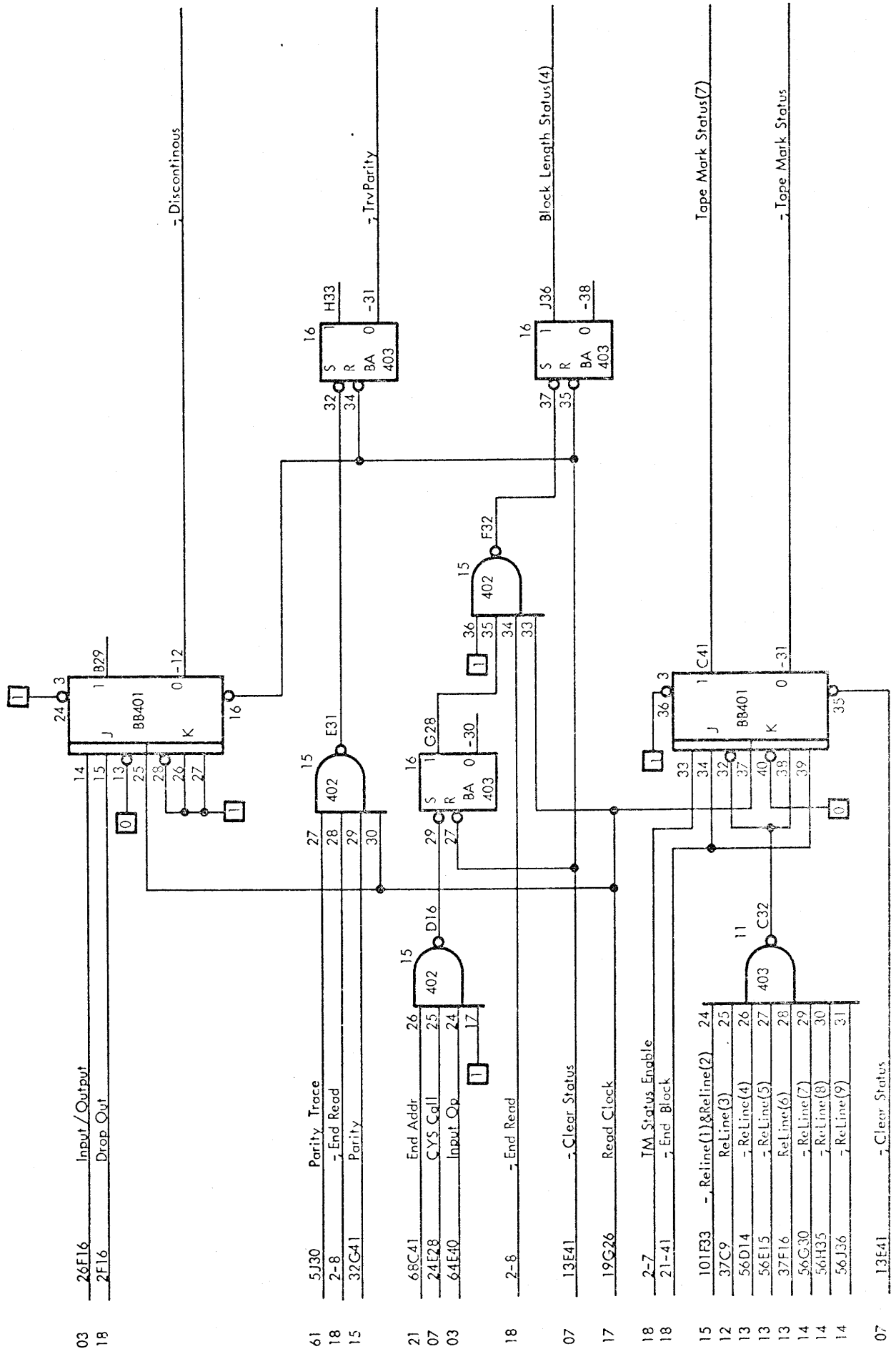

03	26F16	Input/Output	14	1	B29	24	3
18	2F16	Drop Out	15	1	13	25	0
61	5J30	Parity Trace	27	1	15	16	1
18	2-8	- End Read	28	1	15	16	1
15	32G41	Parity	29	1	15	16	1
21	68C41	End Addr	26	1	15	16	1
07	24E28	CYS Cqll	25	1	15	16	1
03	64E40	Input Op	24	1	15	16	1
18	2-8	- End Read	27	1	15	16	1
07	13E41	- Clear Status	29	1	15	16	1
17	19G26	Read Clock	27	1	15	16	1
18	2-7	TM Status Enable	33	1	15	16	1
18	21-41	- End Block	34	1	15	16	1
15	101F33	- ReLine(1)&ReLine(2)	24	1	15	16	1
12	37C9	ReLine(3)	25	1	15	16	1
13	56D14	- ReLine(4)	26	1	15	16	1
13	56E15	- ReLine(5)	27	1	15	16	1
13	37F16	ReLine(6)	28	1	15	16	1
14	56G30	- ReLine(7)	29	1	15	16	1
14	56H35	- ReLine(8)	30	1	15	16	1
14	56J36	- ReLine(9)	31	1	15	16	1
07	13E41	- Clear Status	29	1	15	16	1

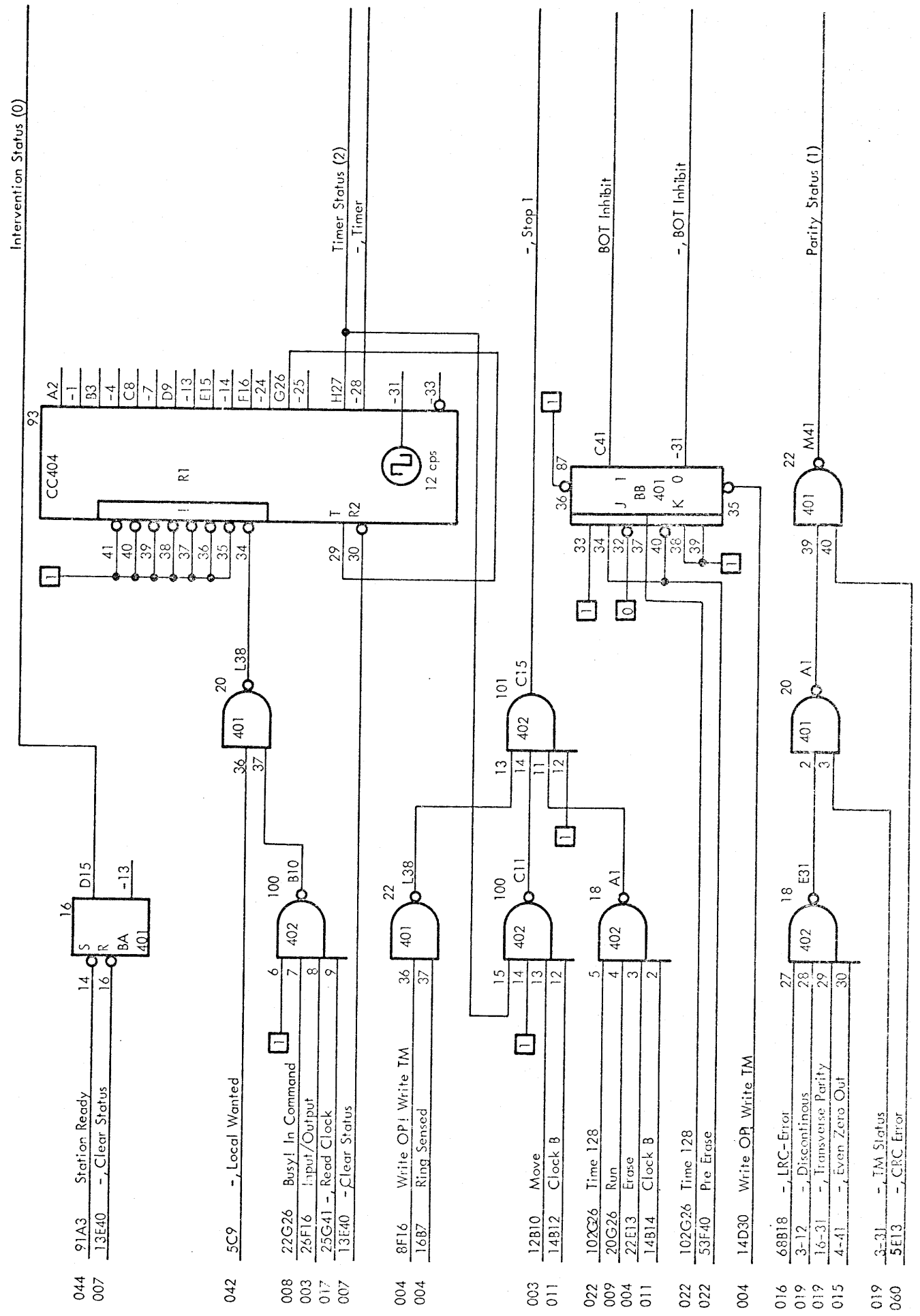

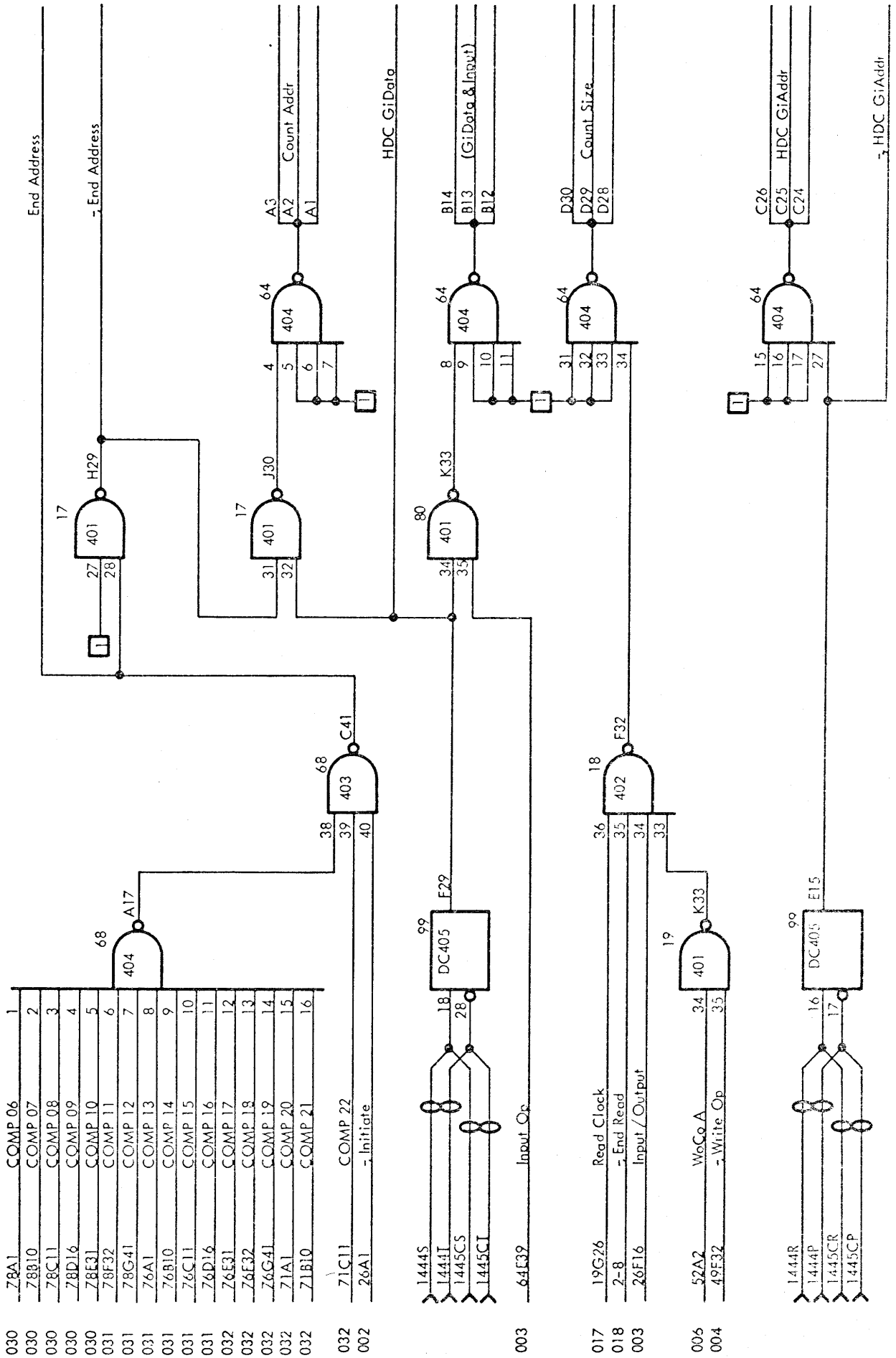

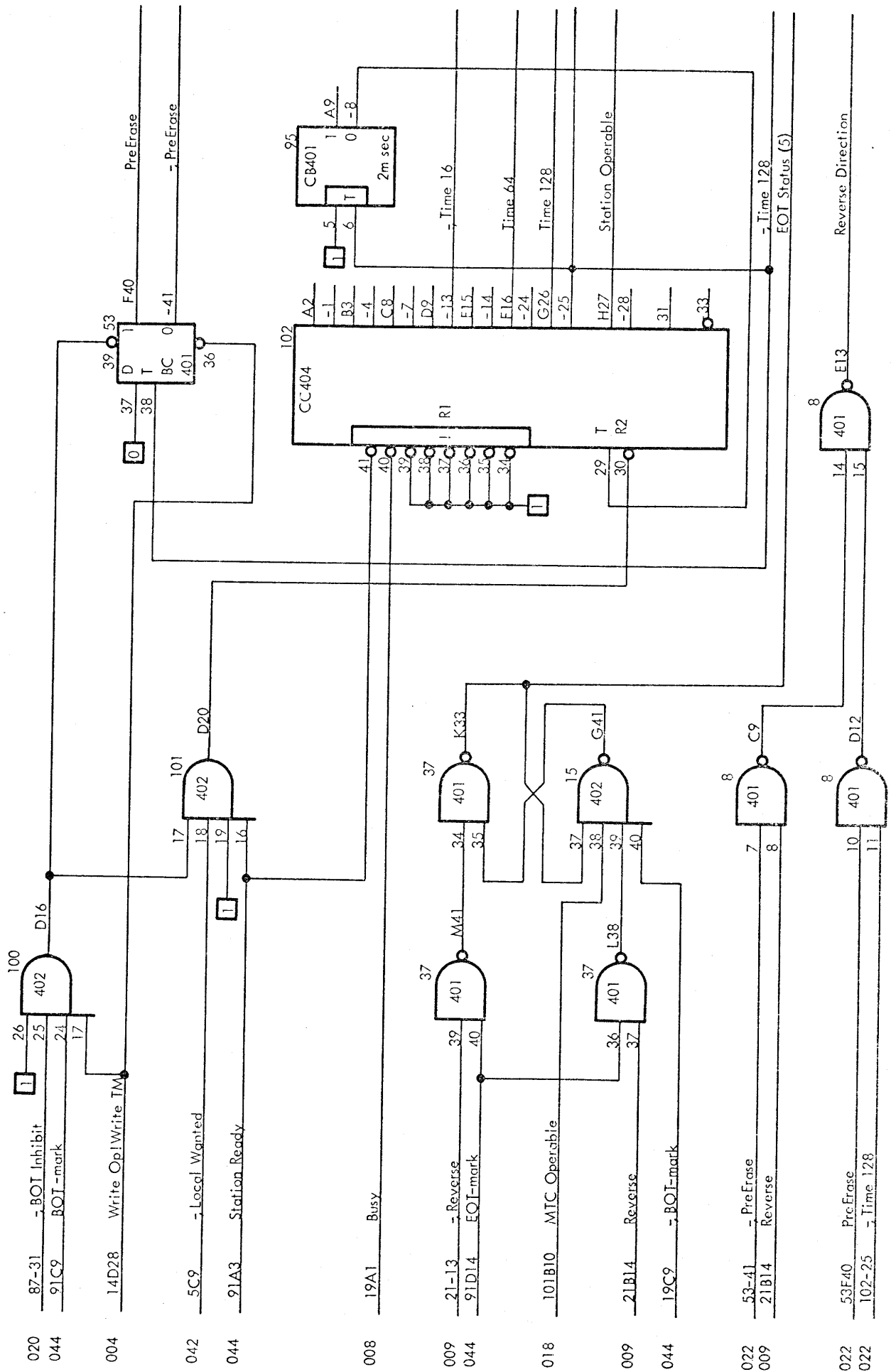

PRE-ERASE TIMING AND EOT STATUS CIRCUITS

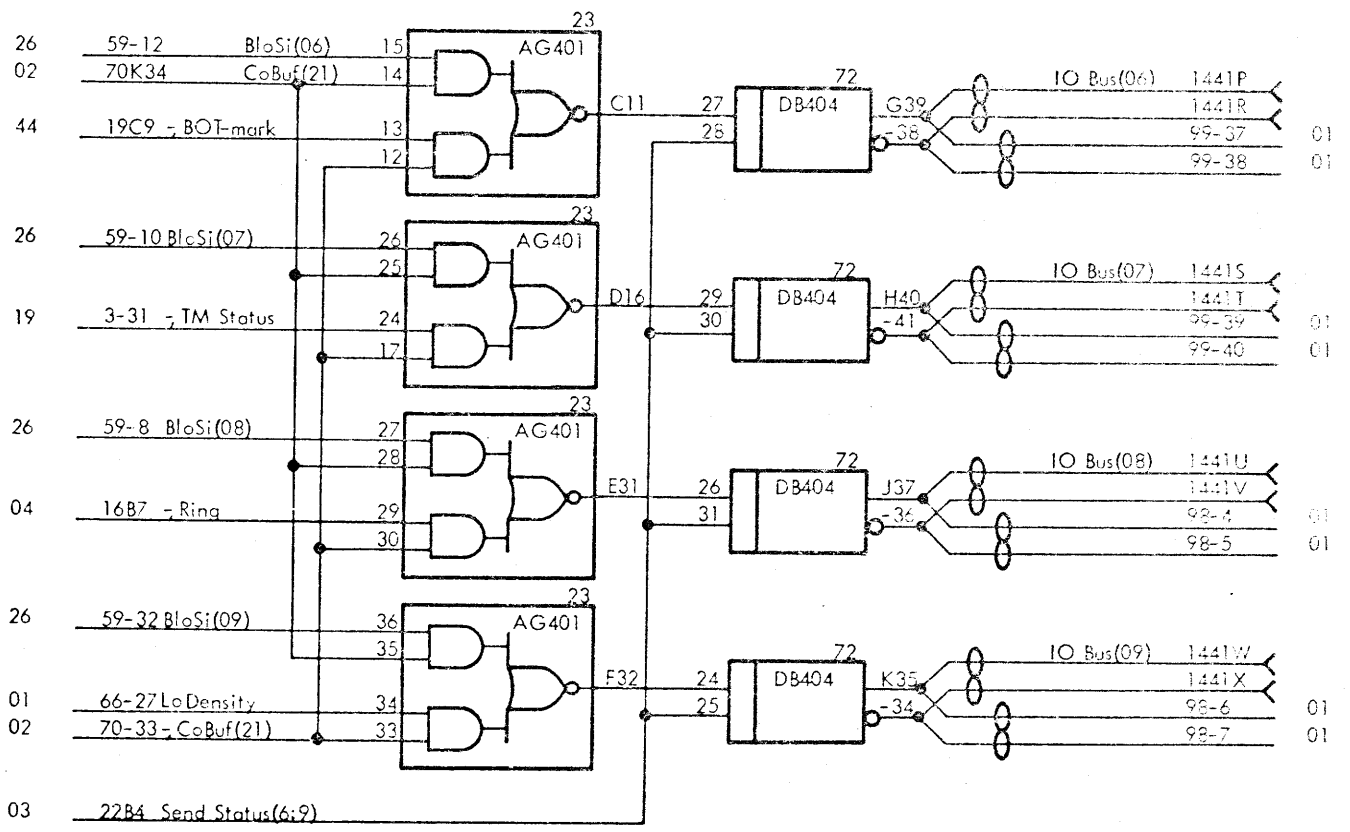
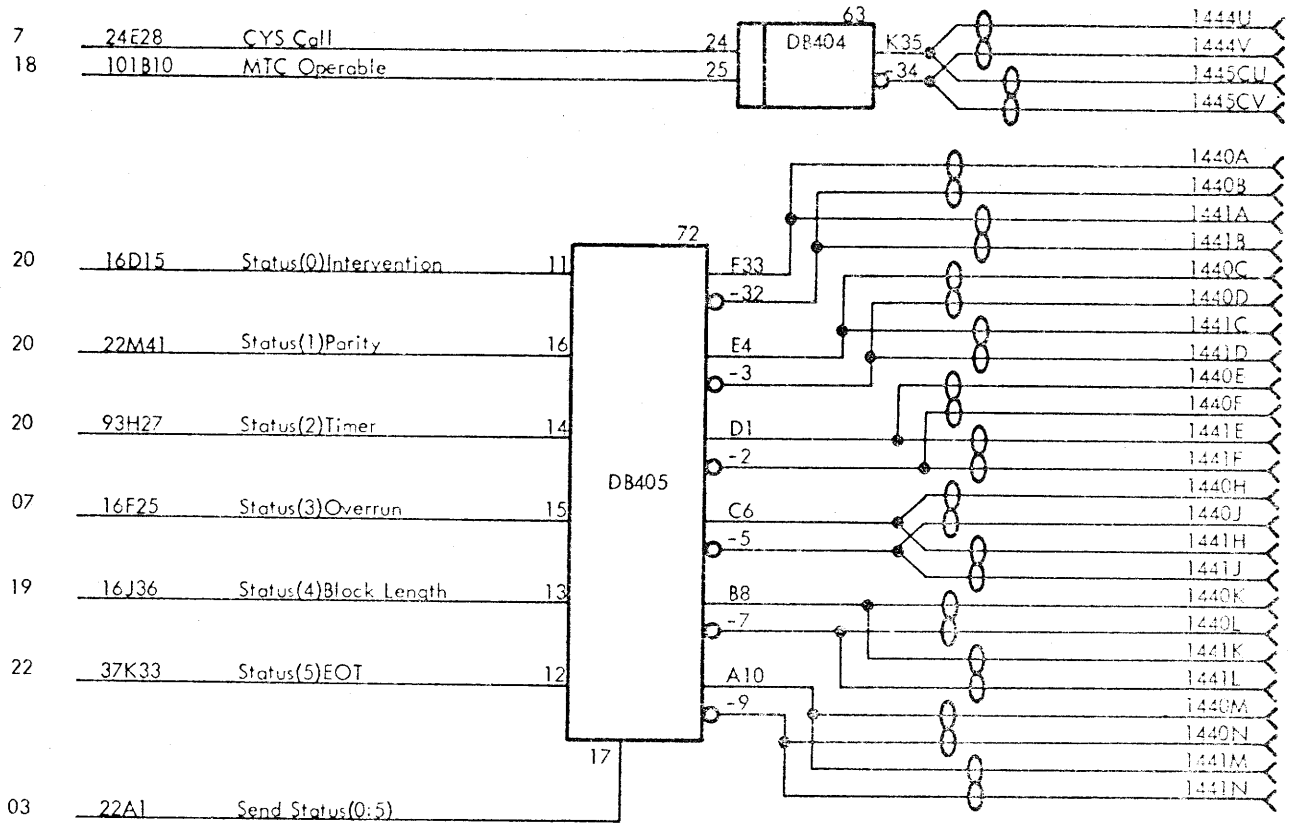

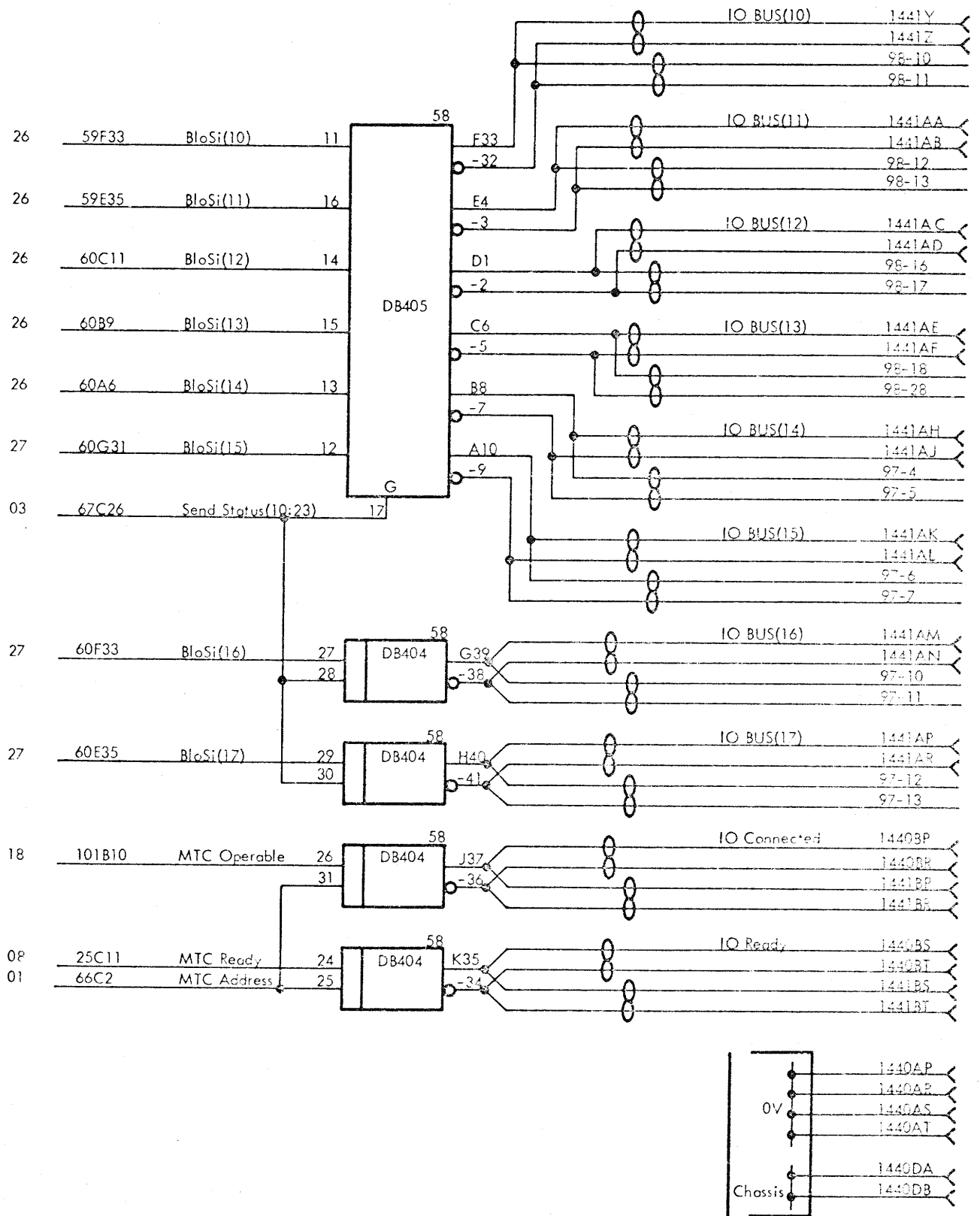



220469JQG 190570HA 30071242 170870J0G V11287

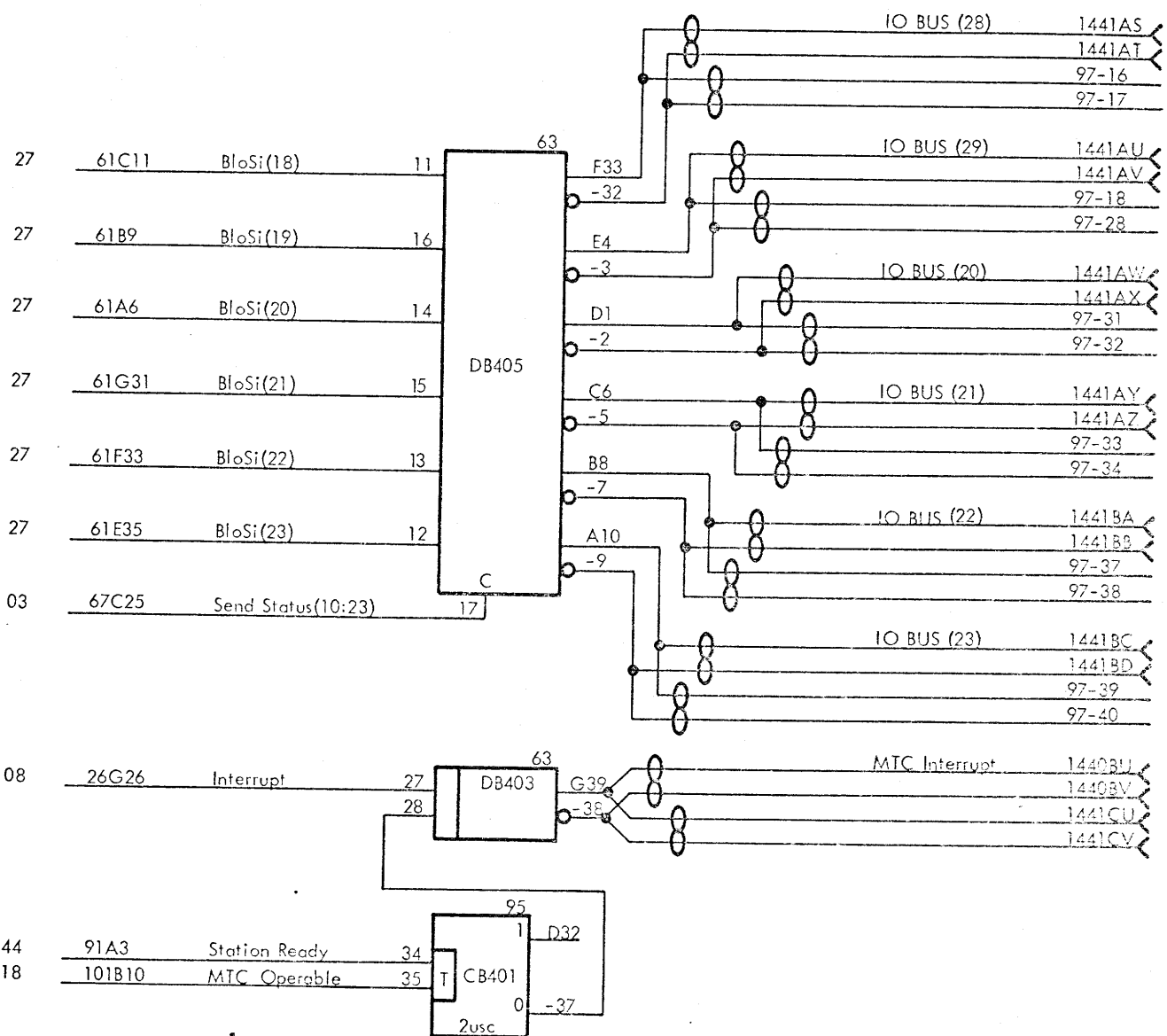

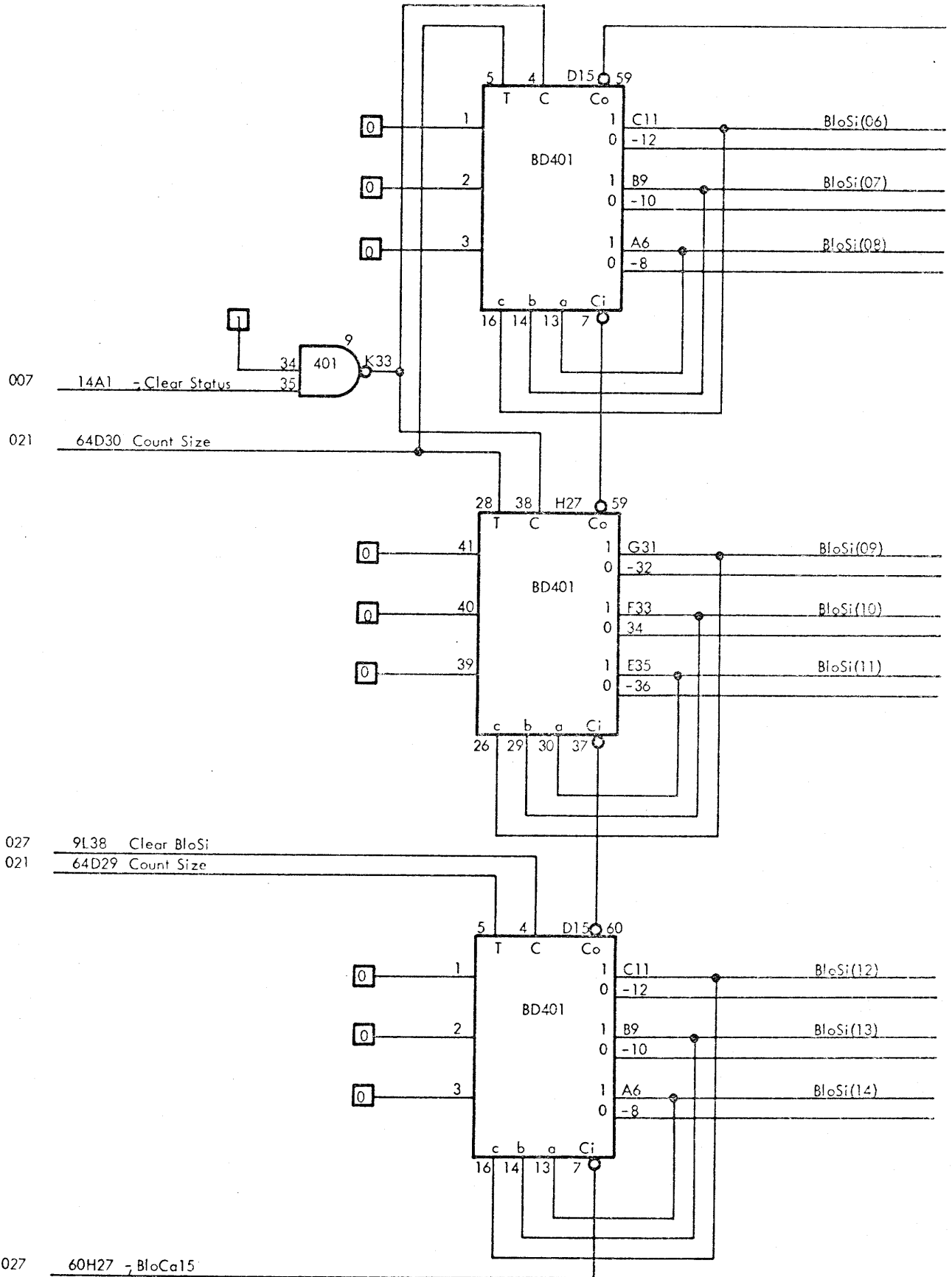

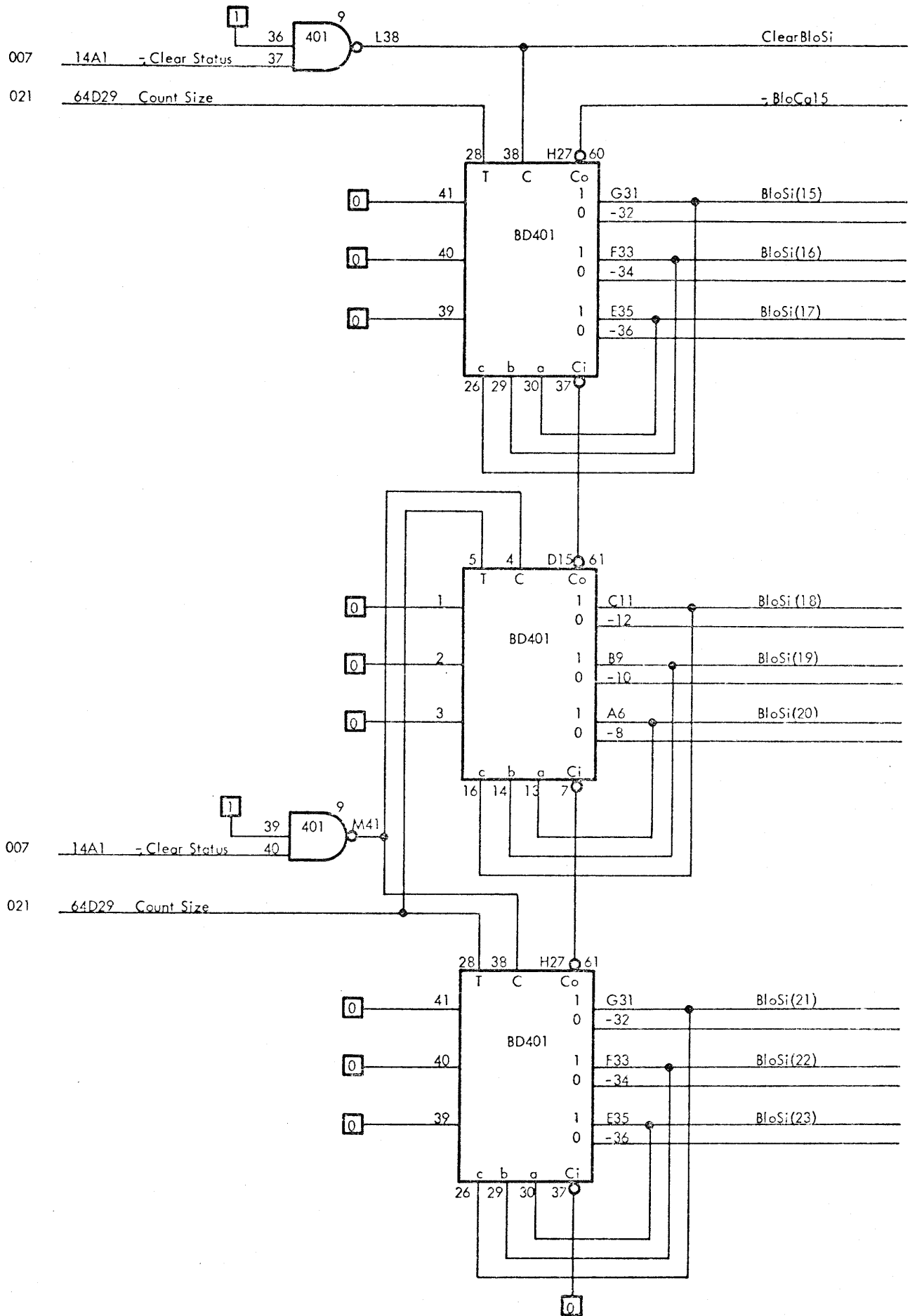

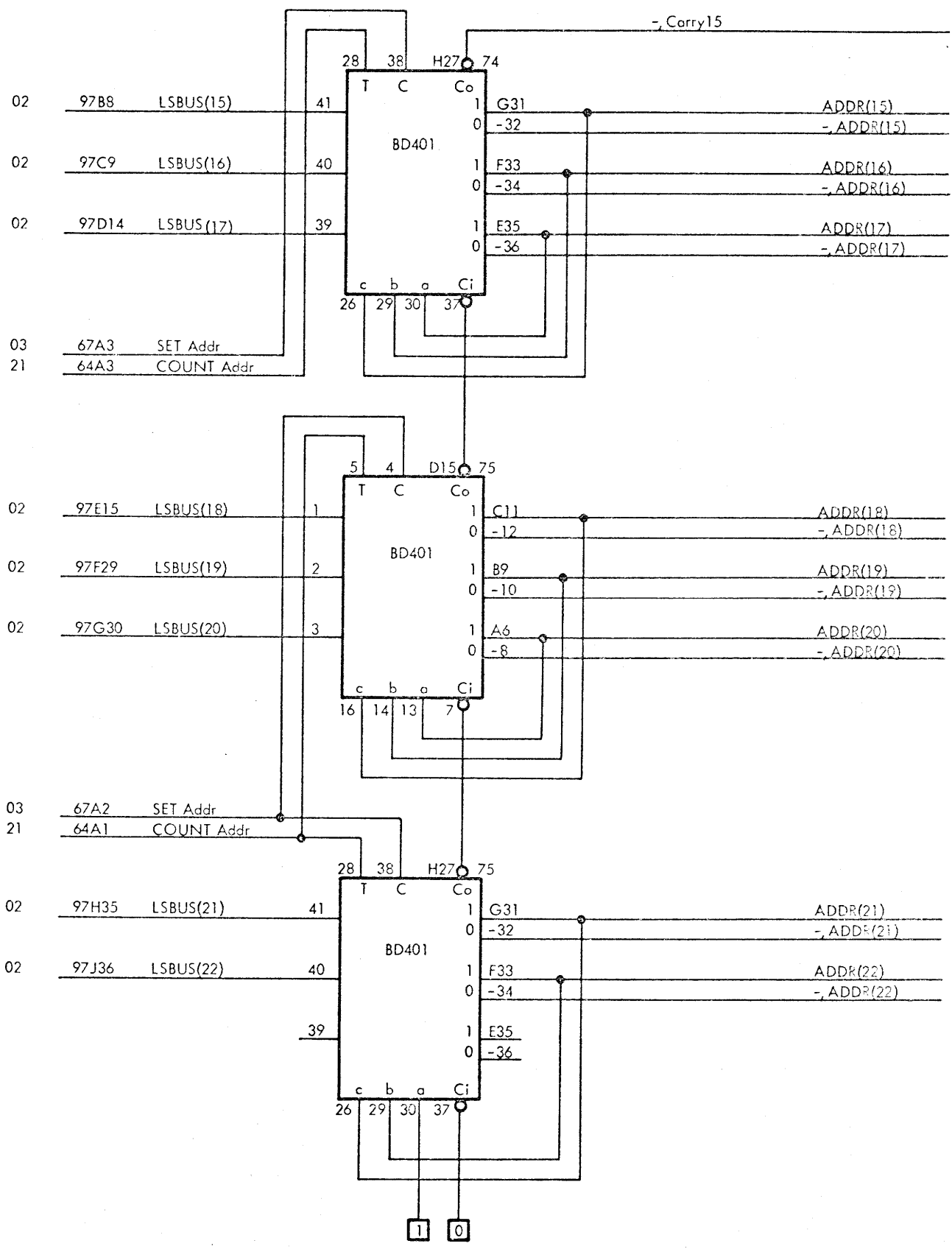

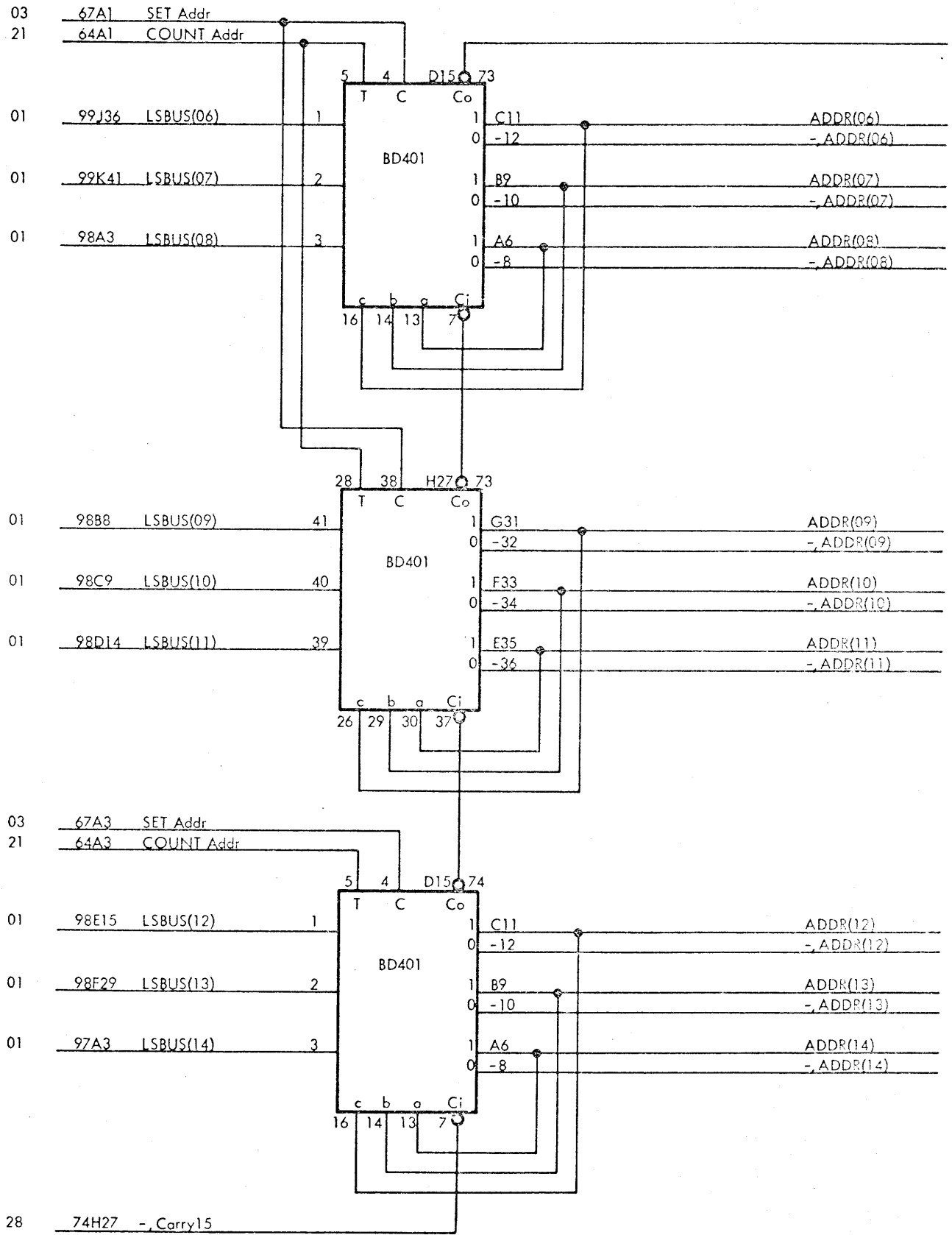

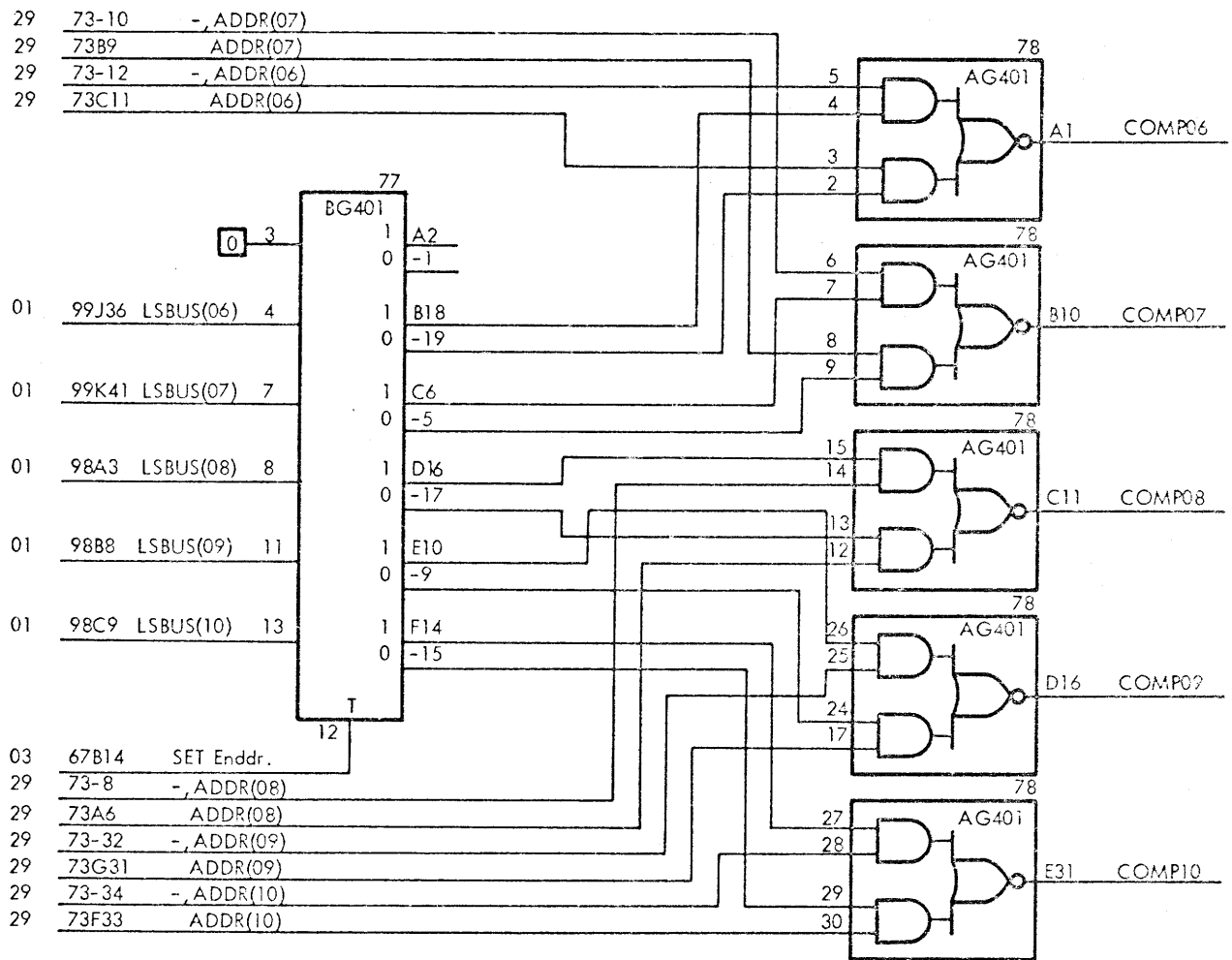

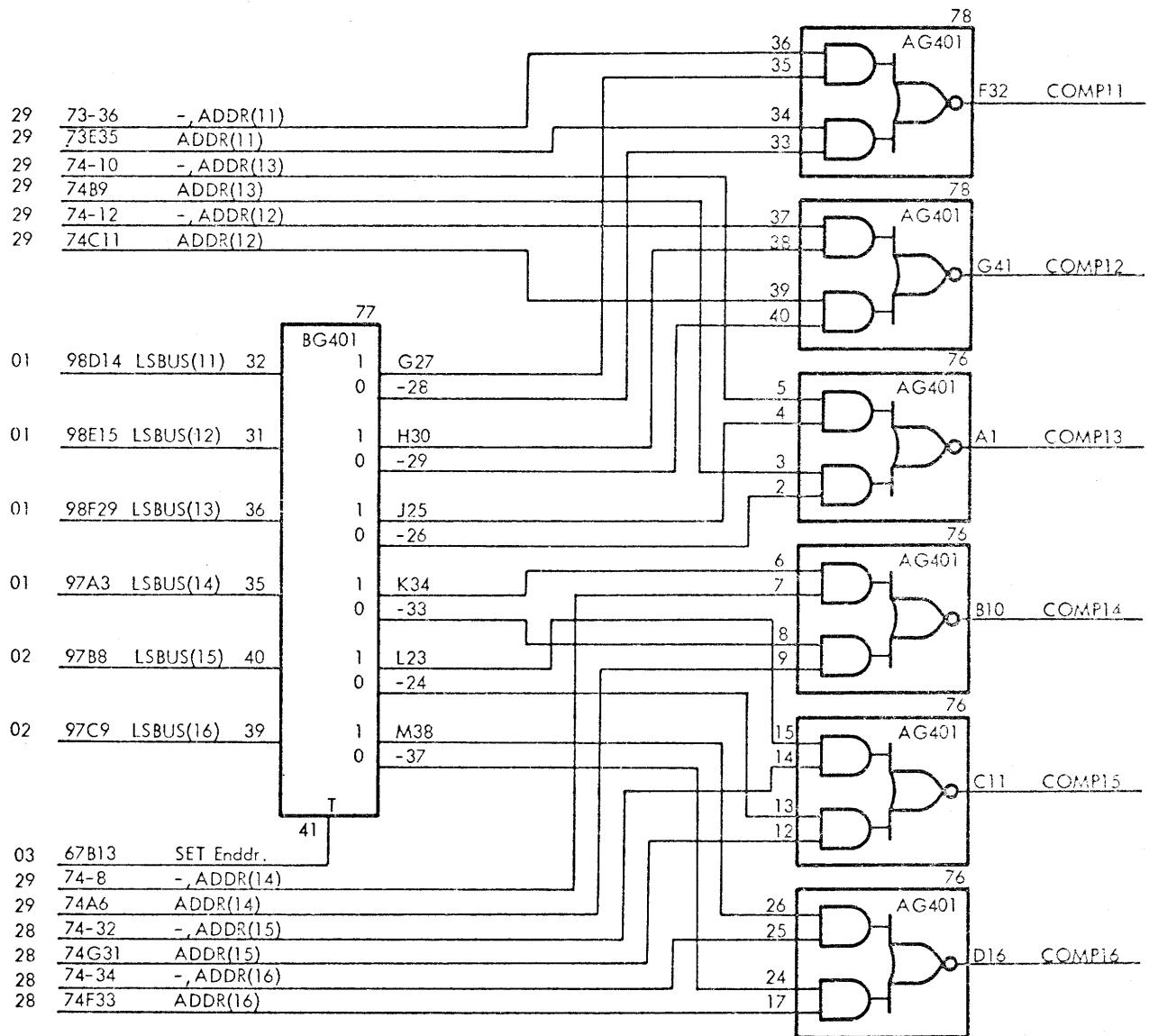

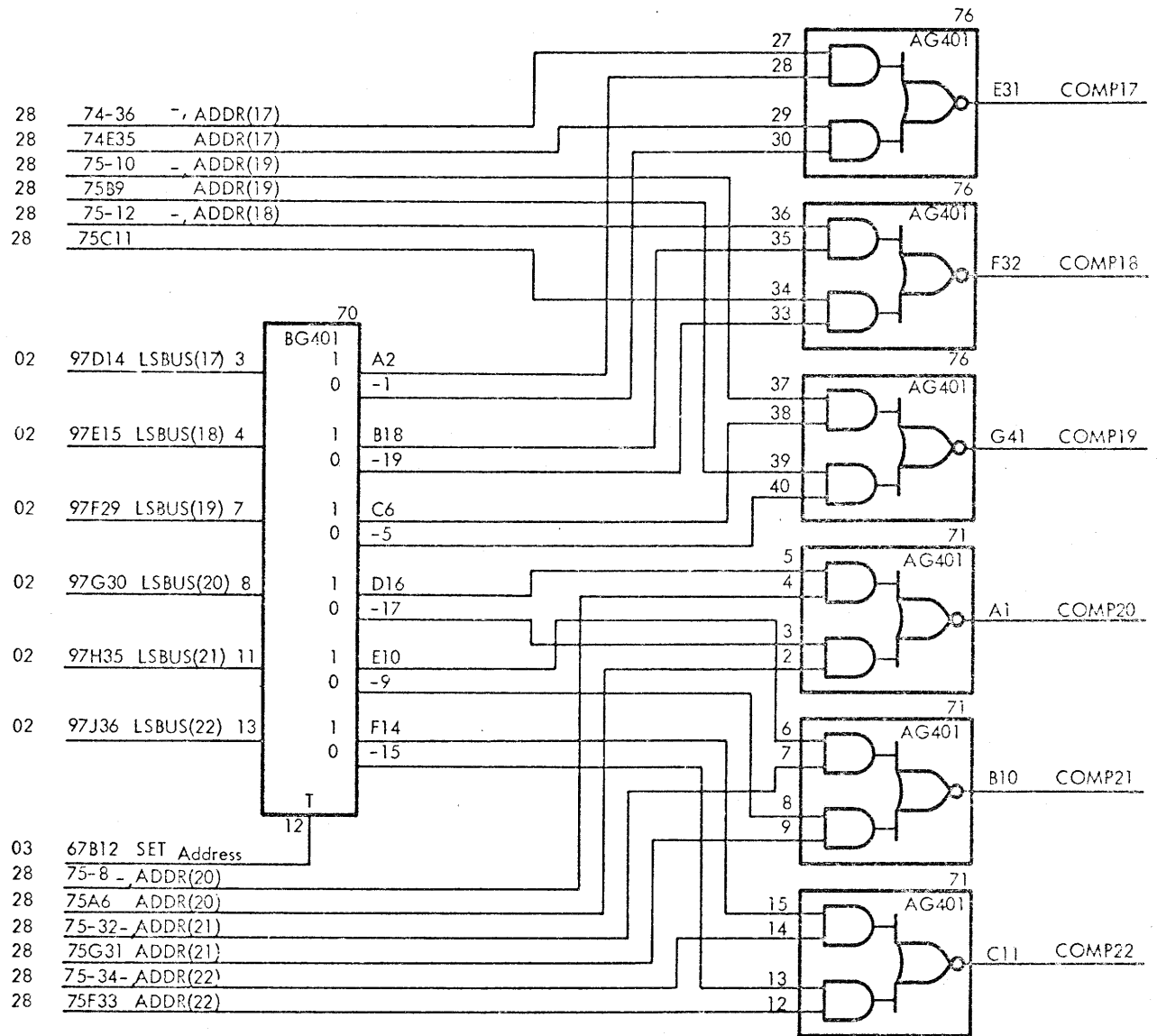



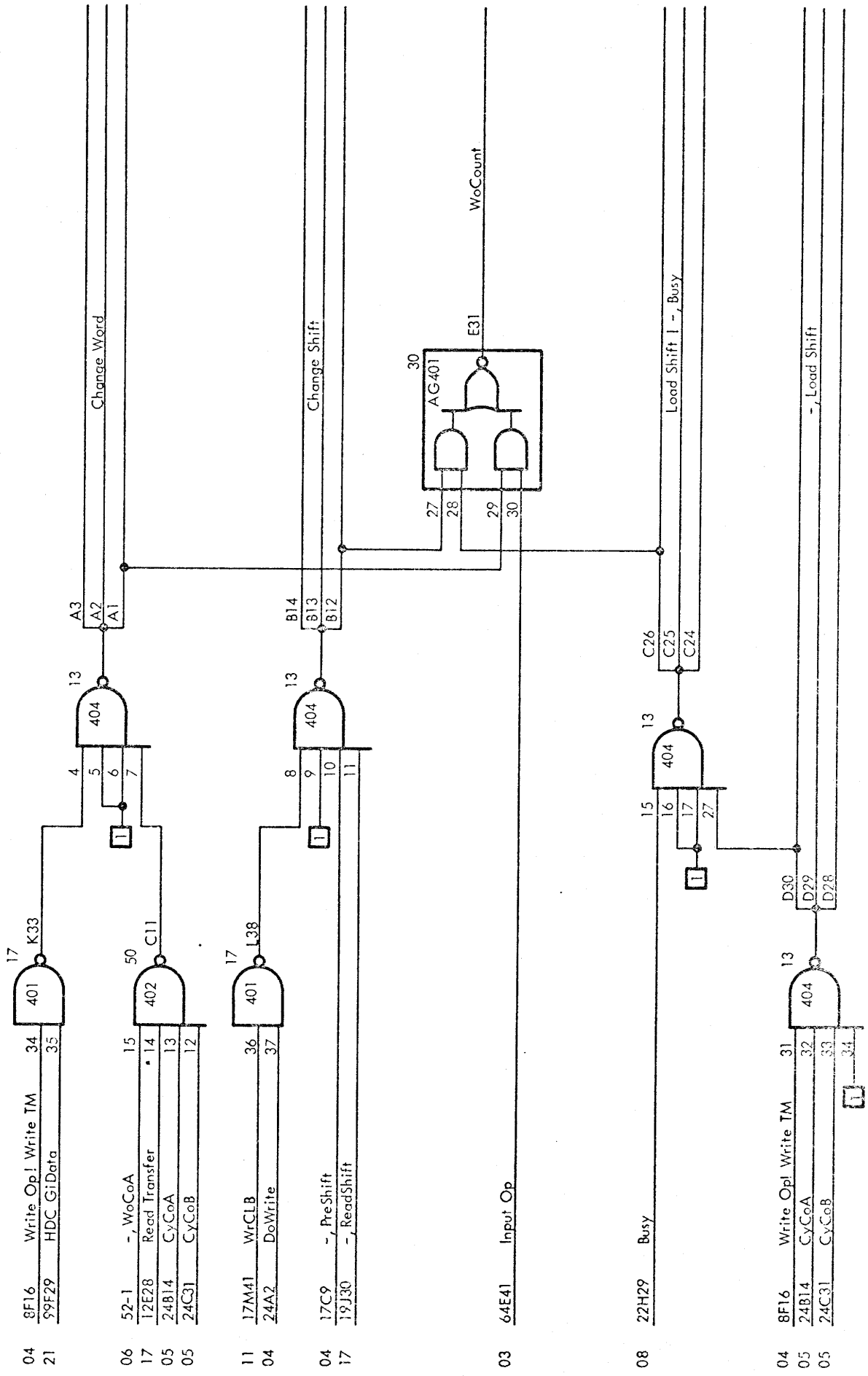

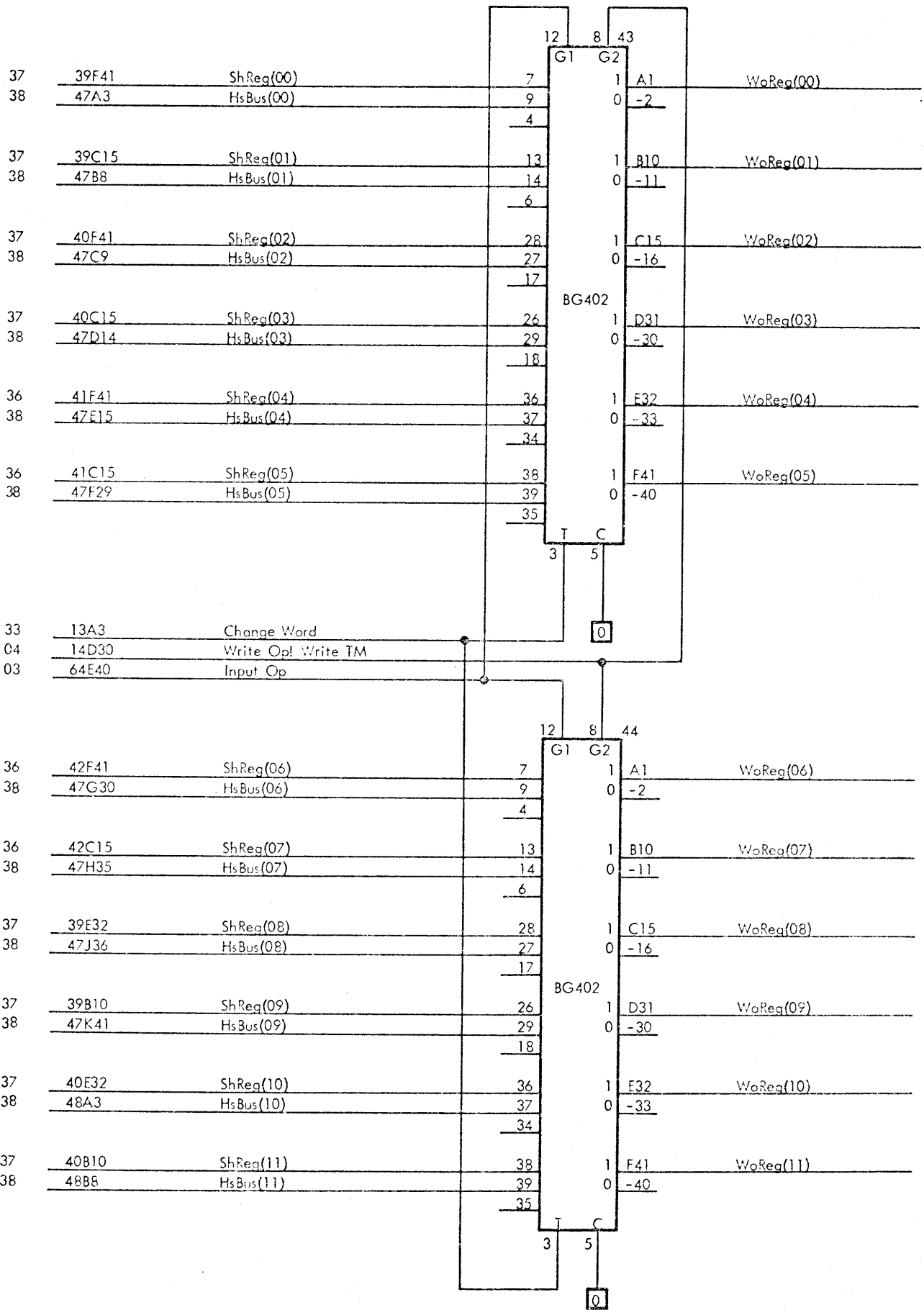

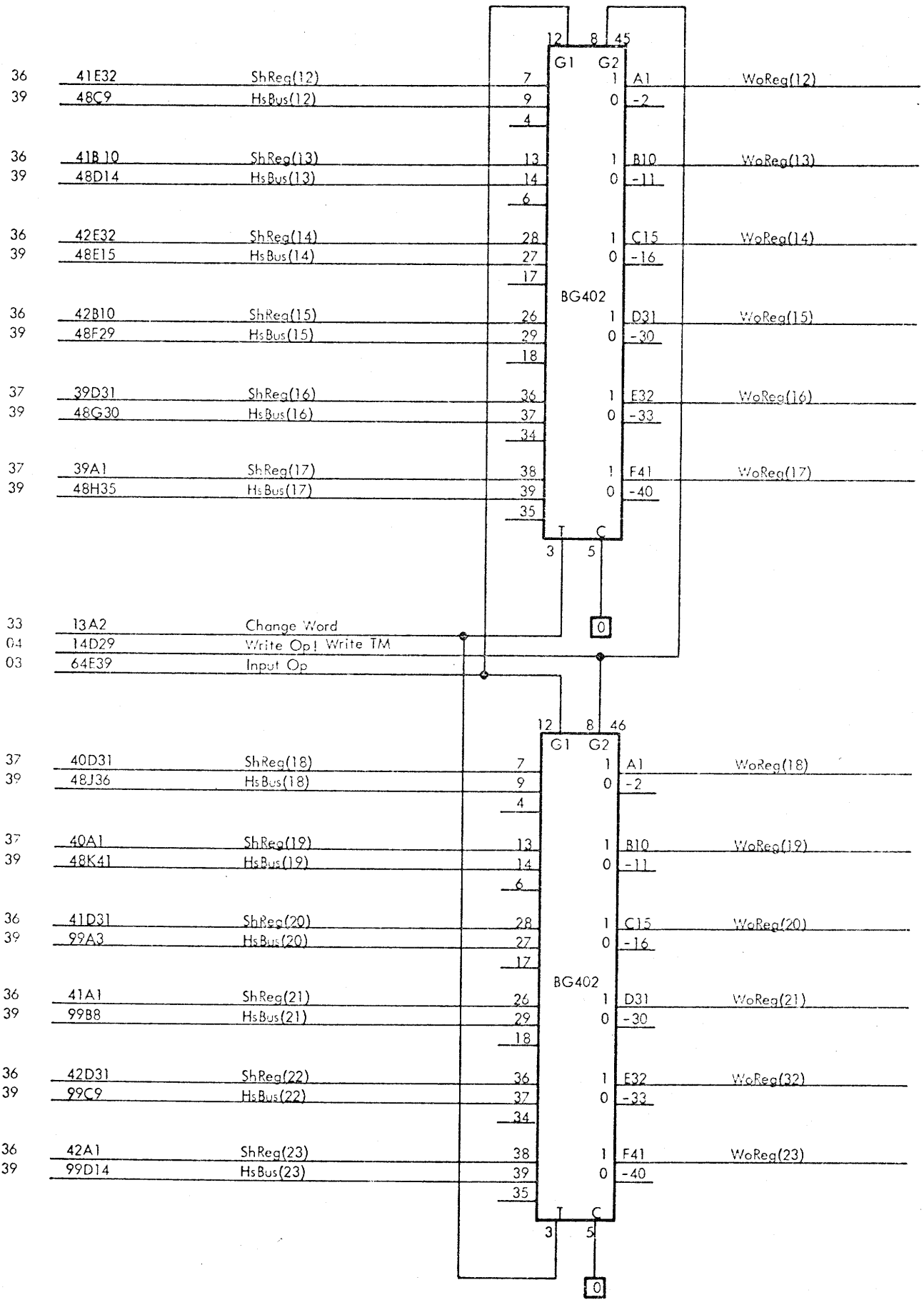

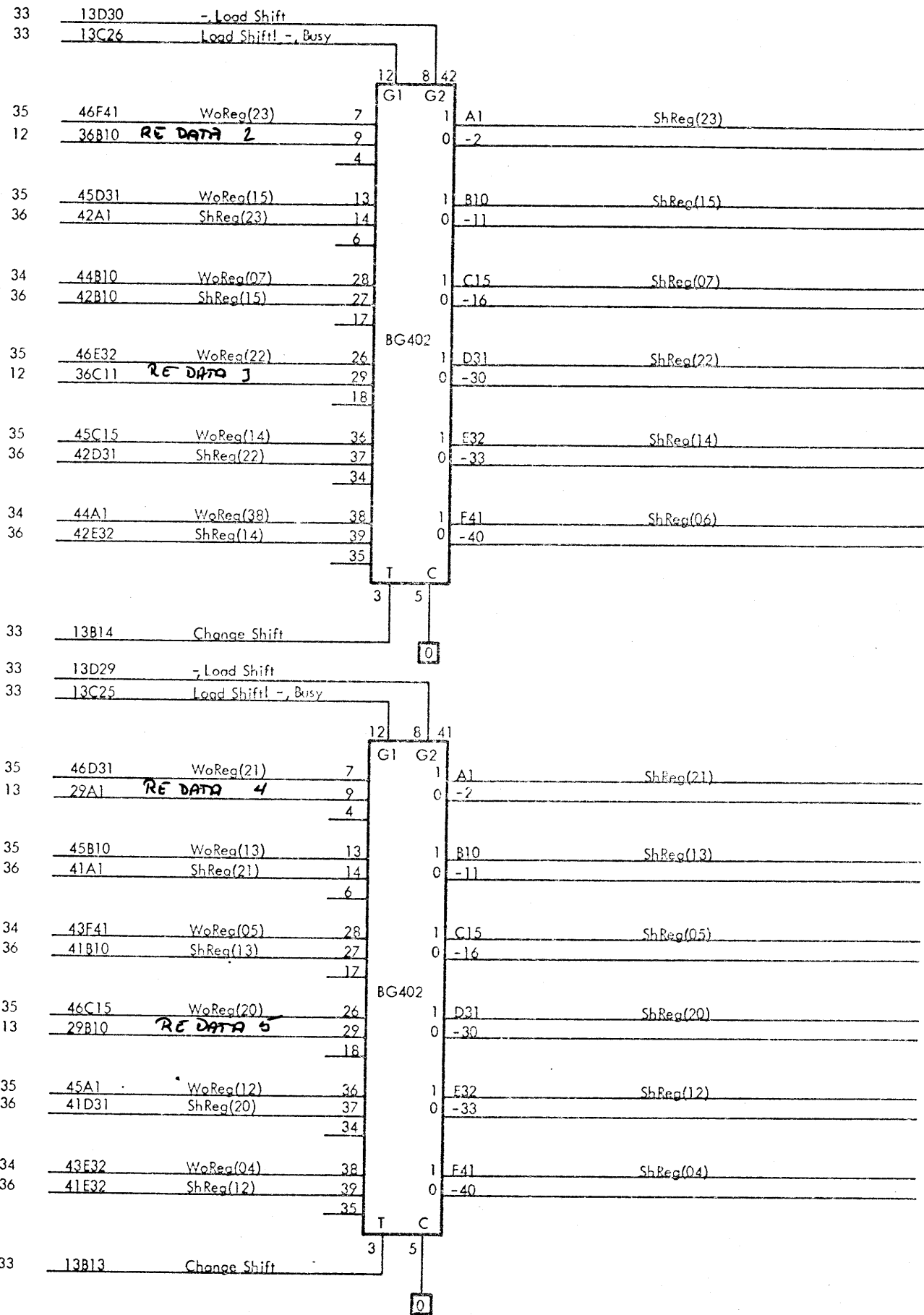

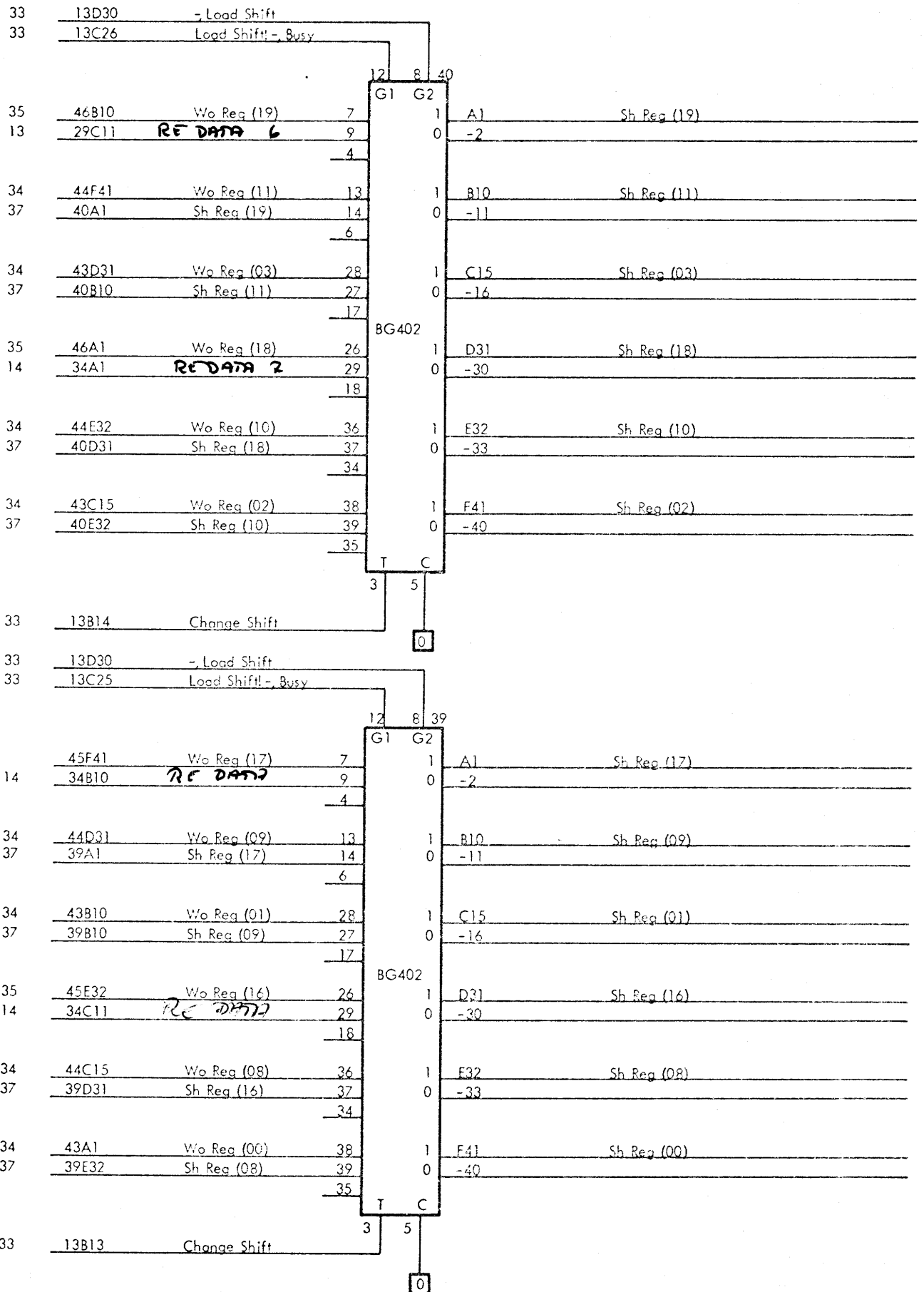

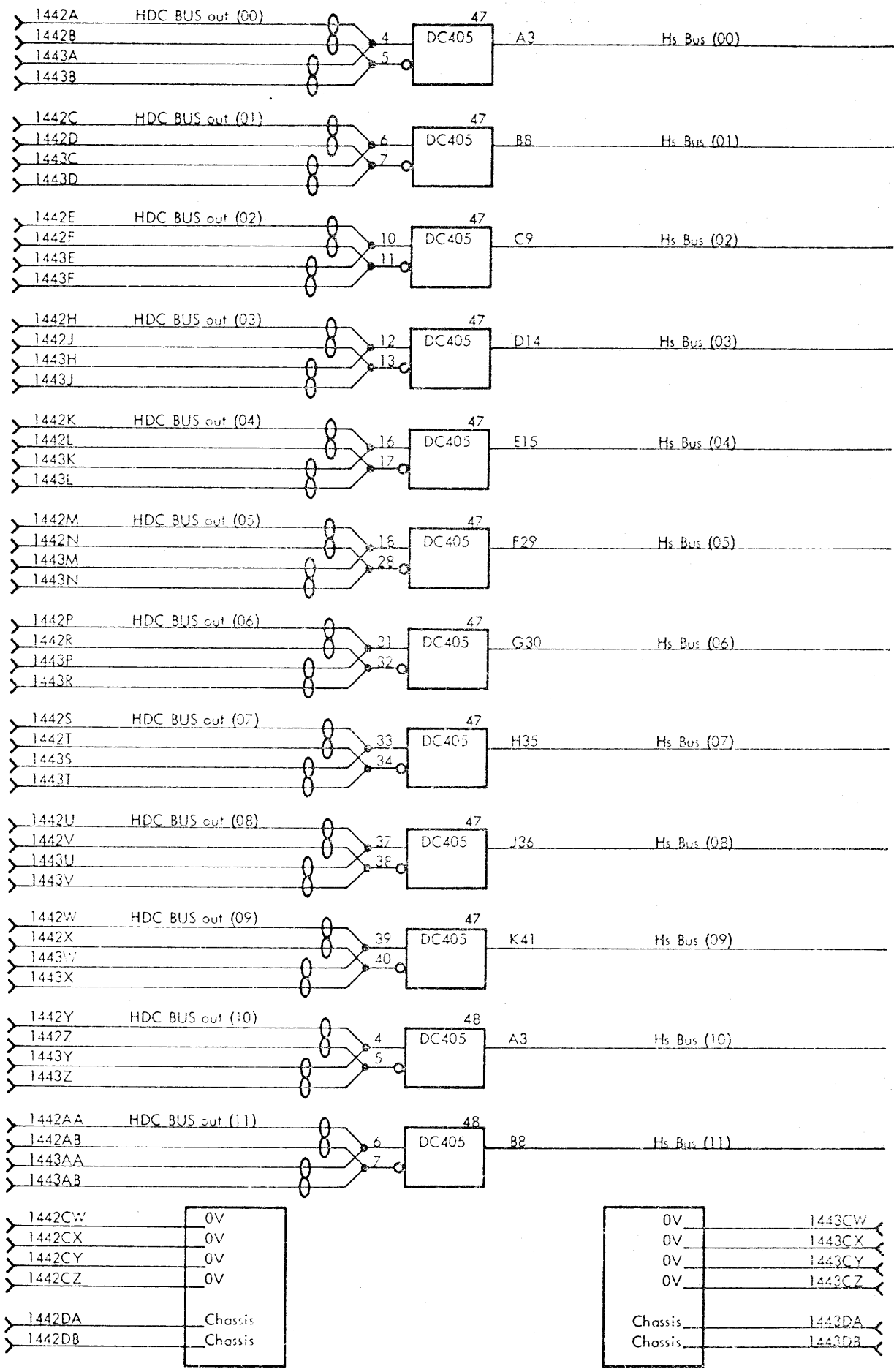

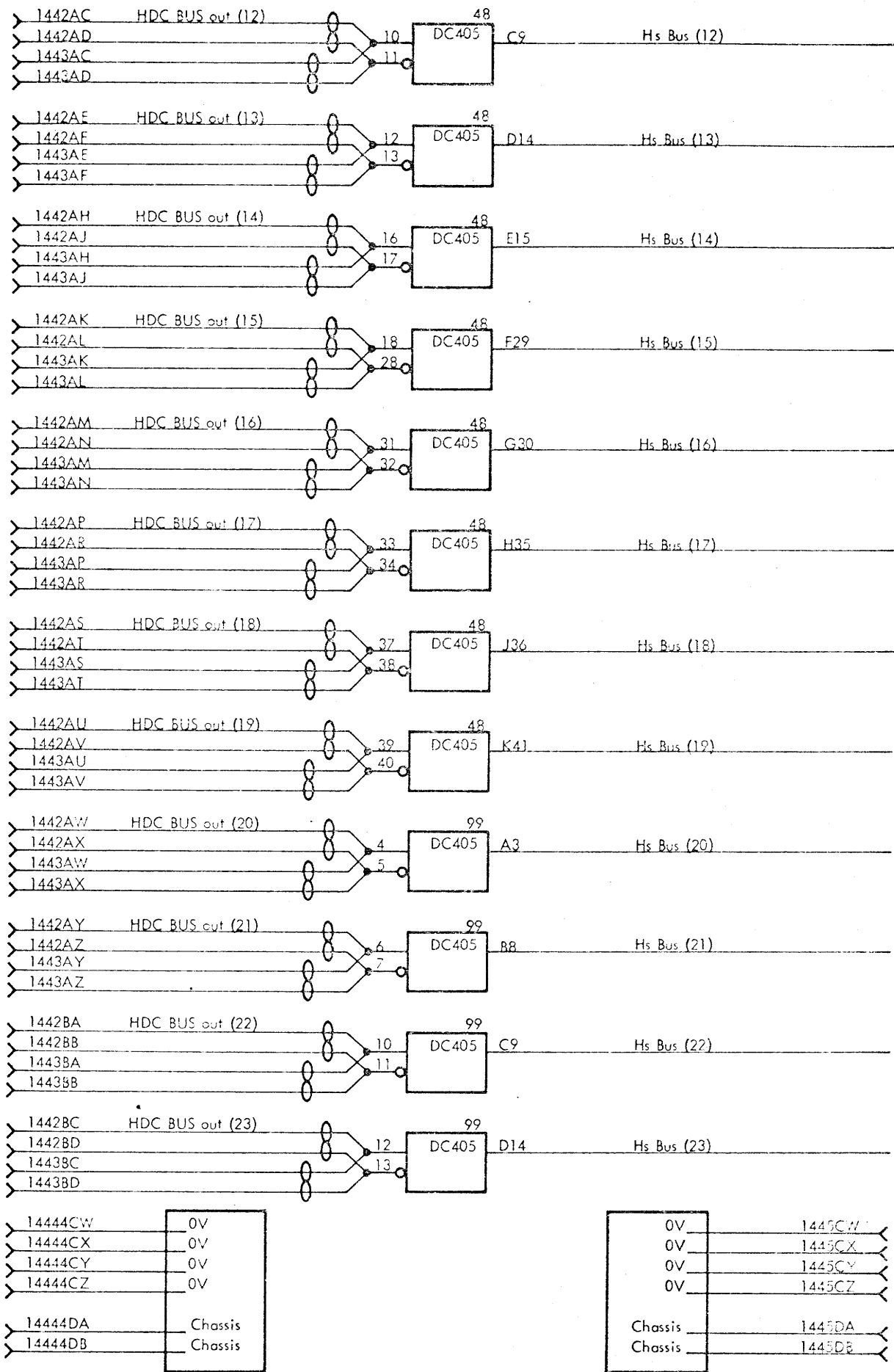

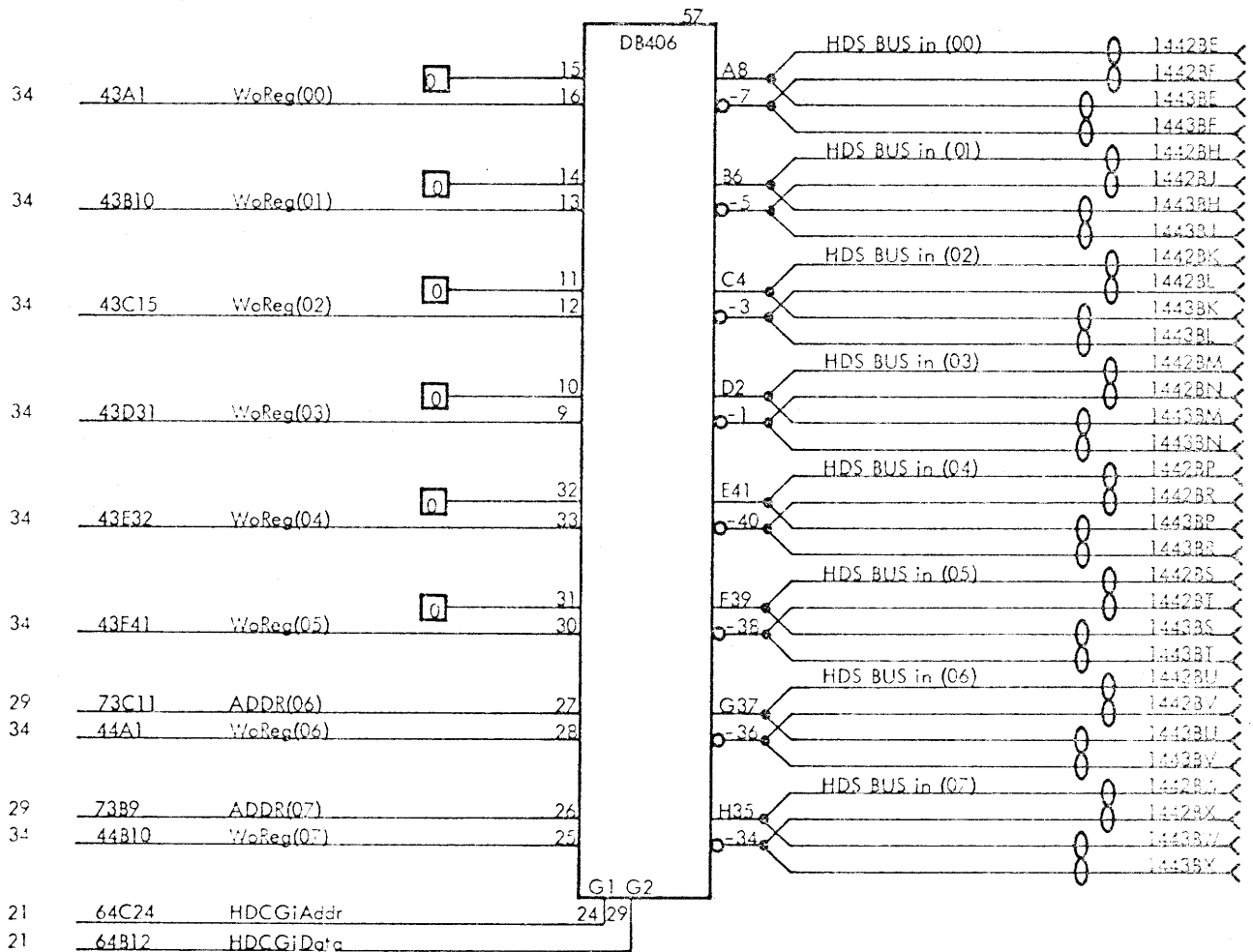



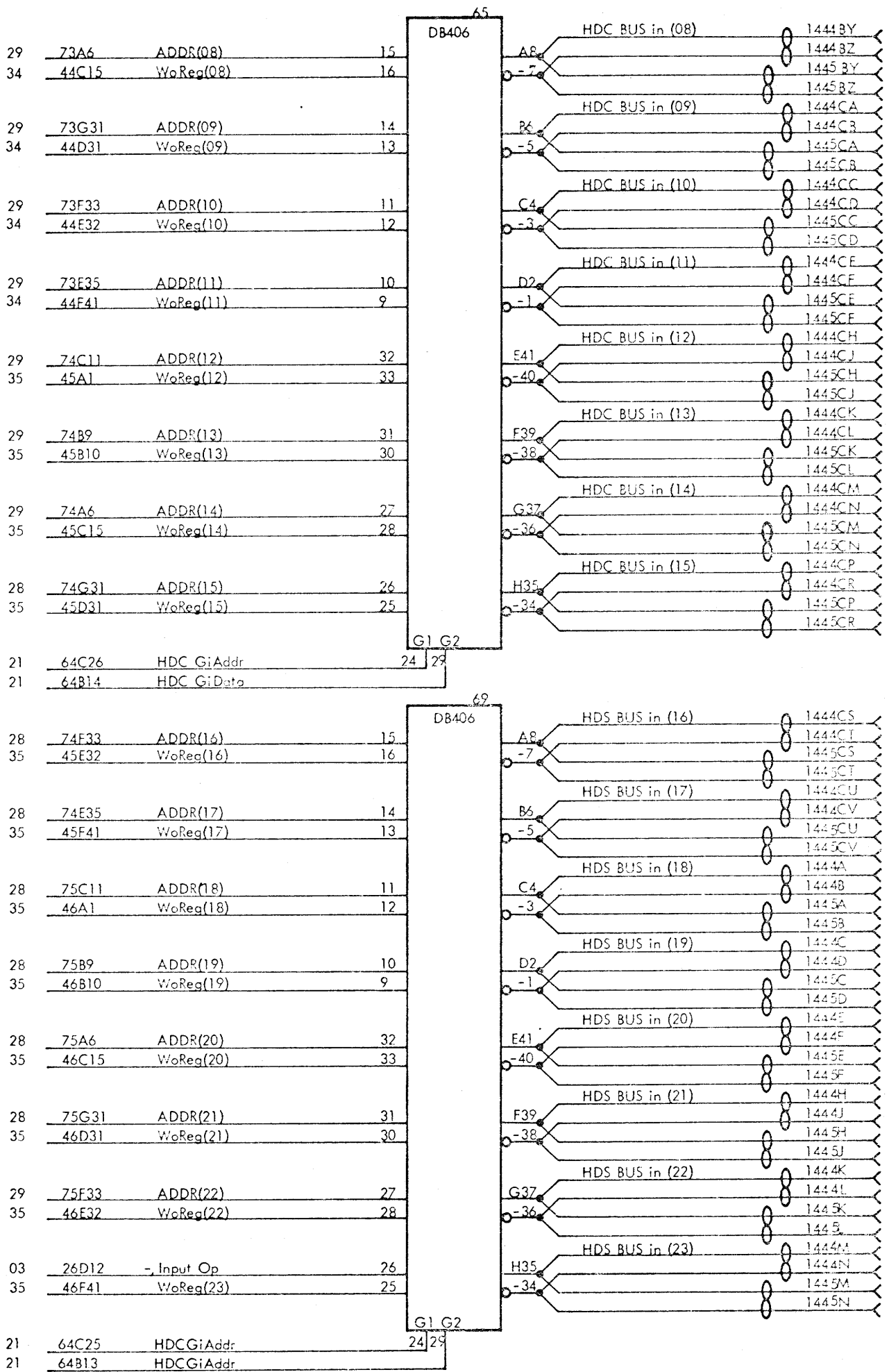

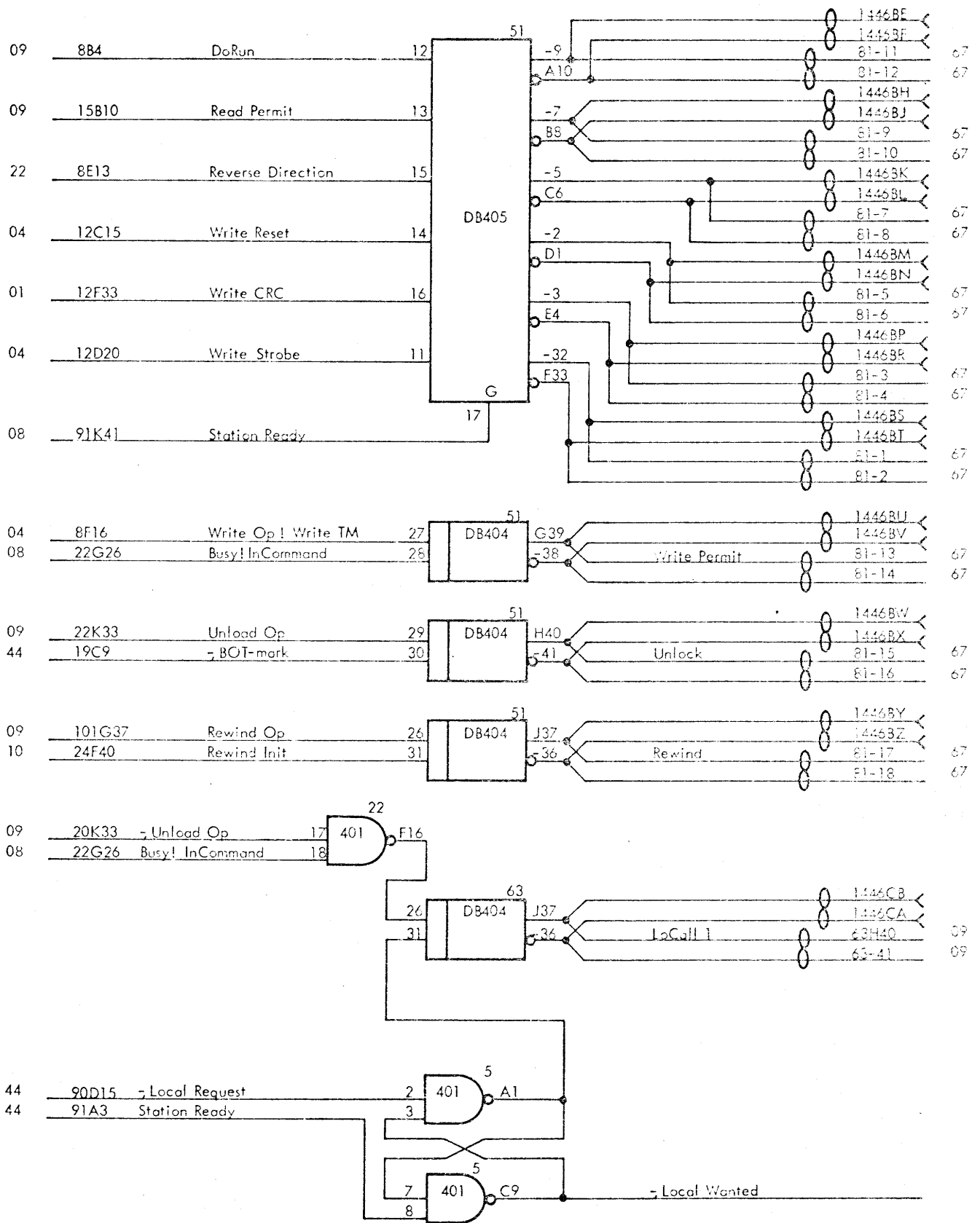

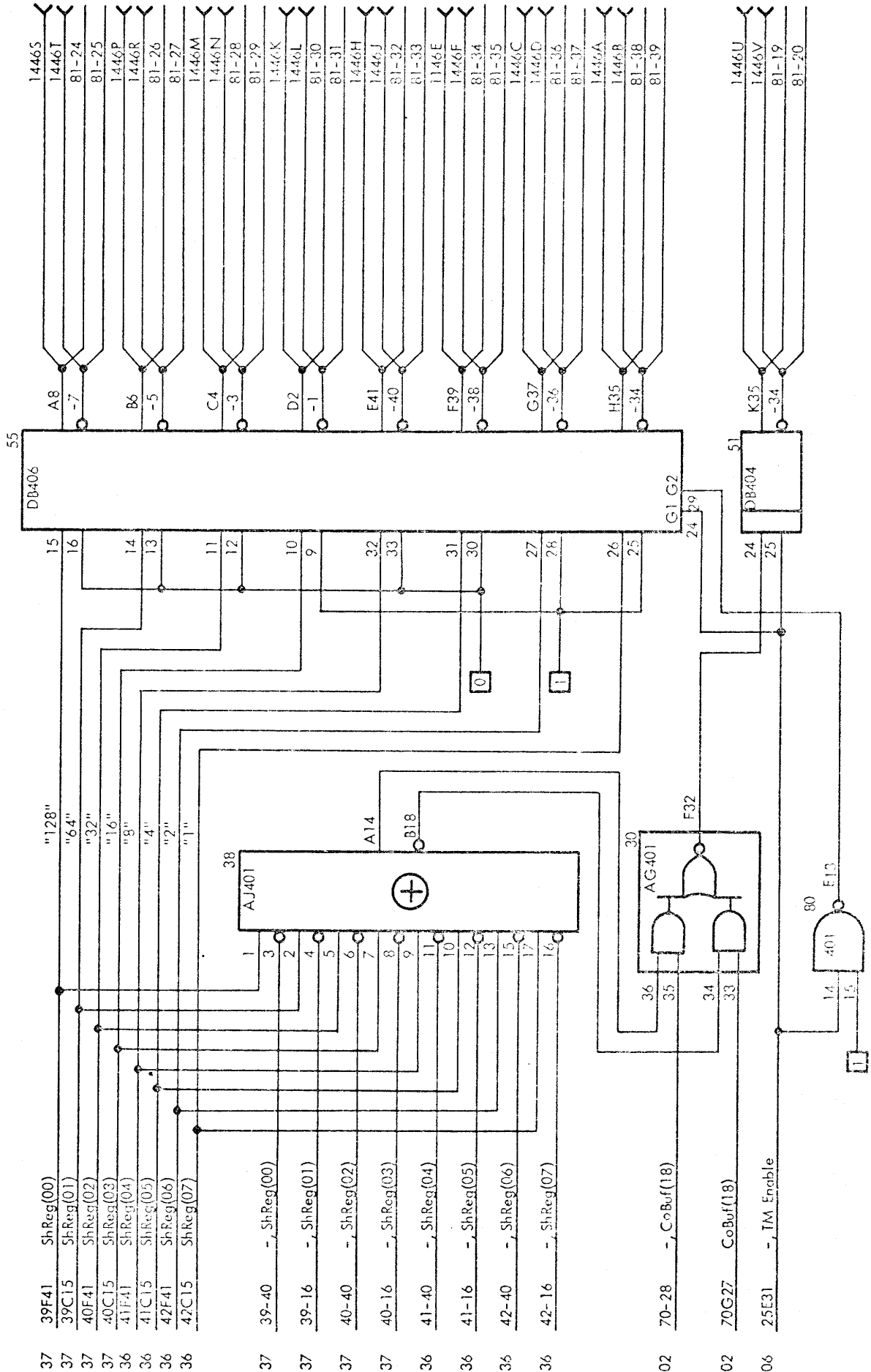

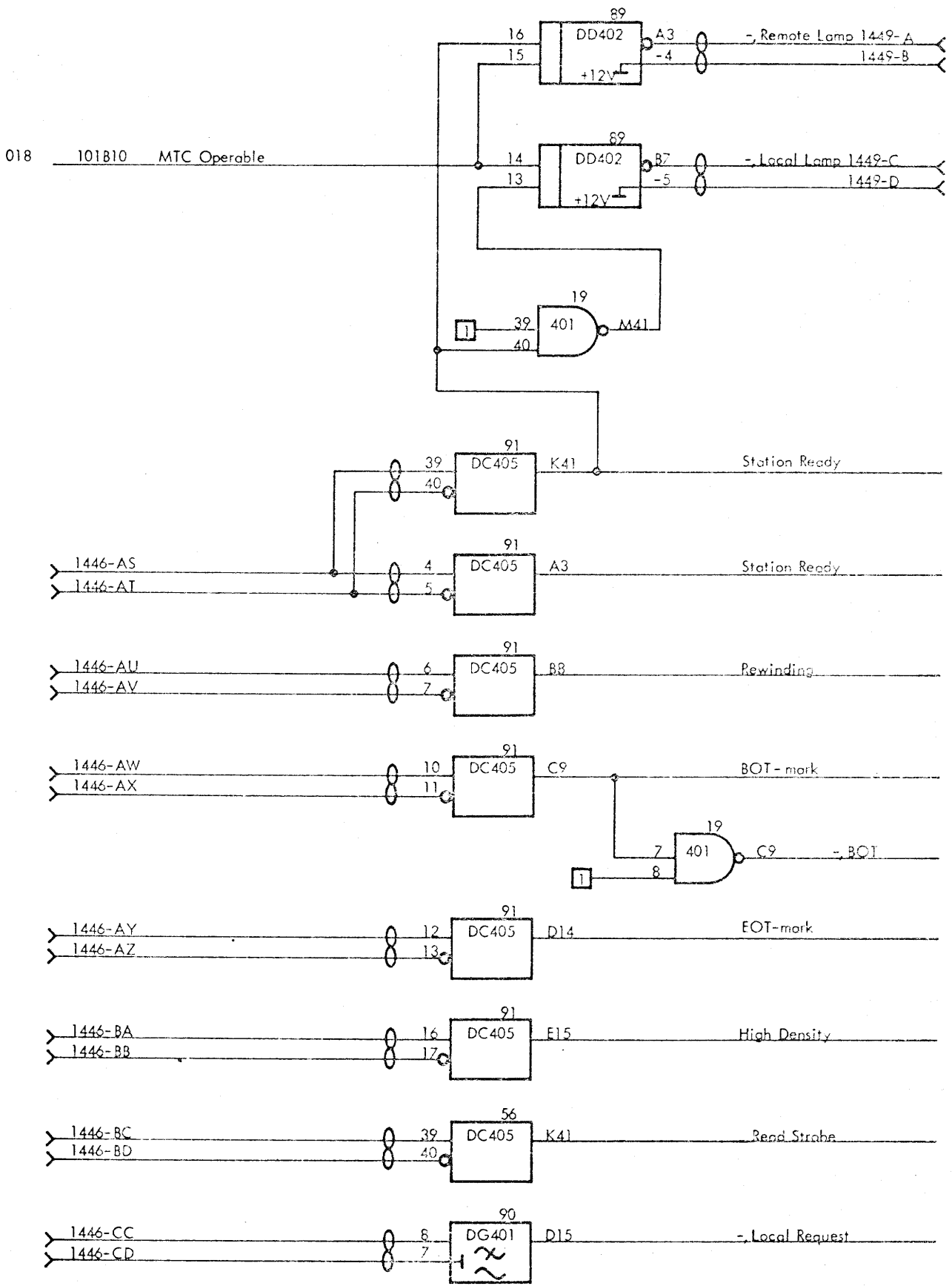

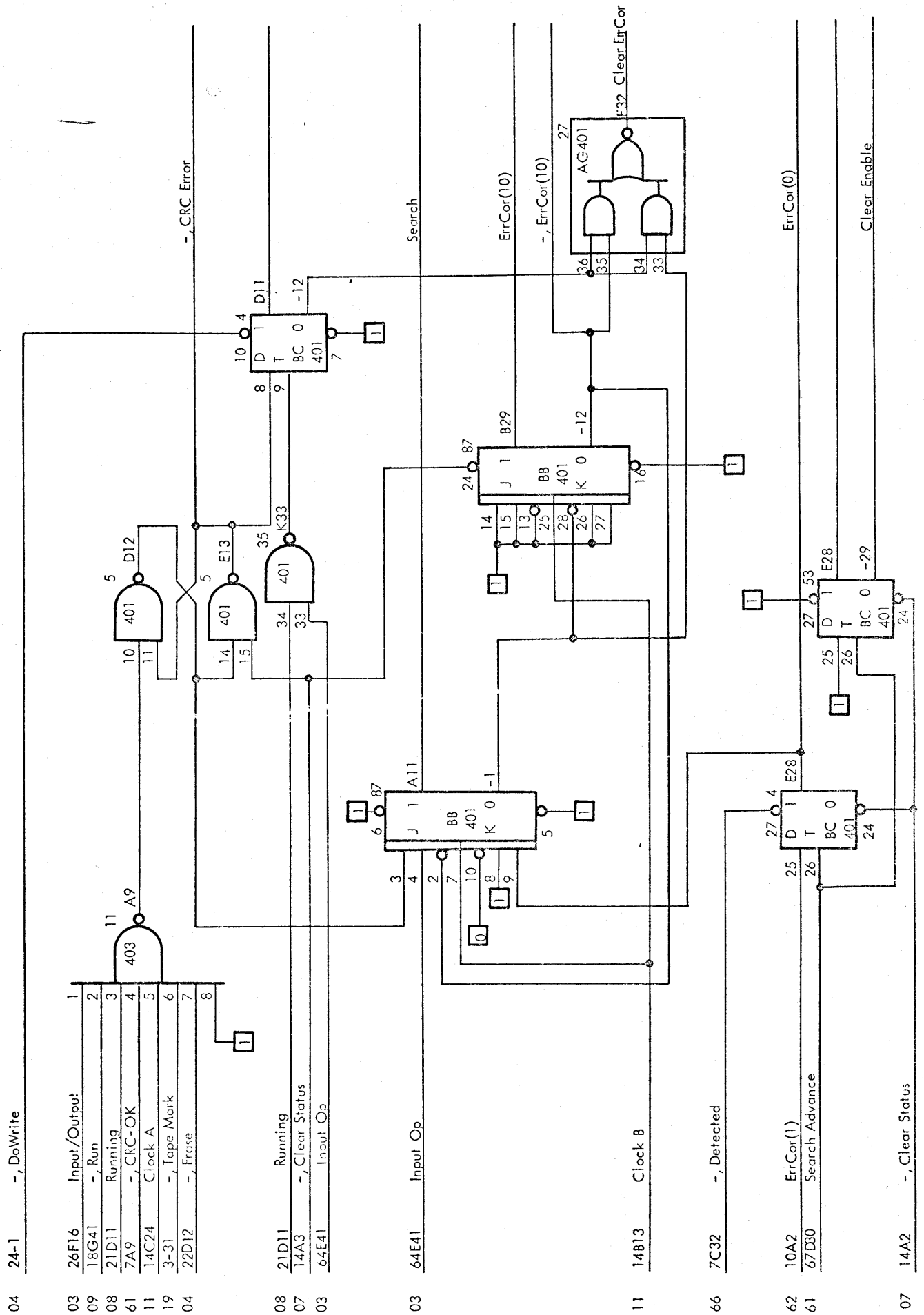

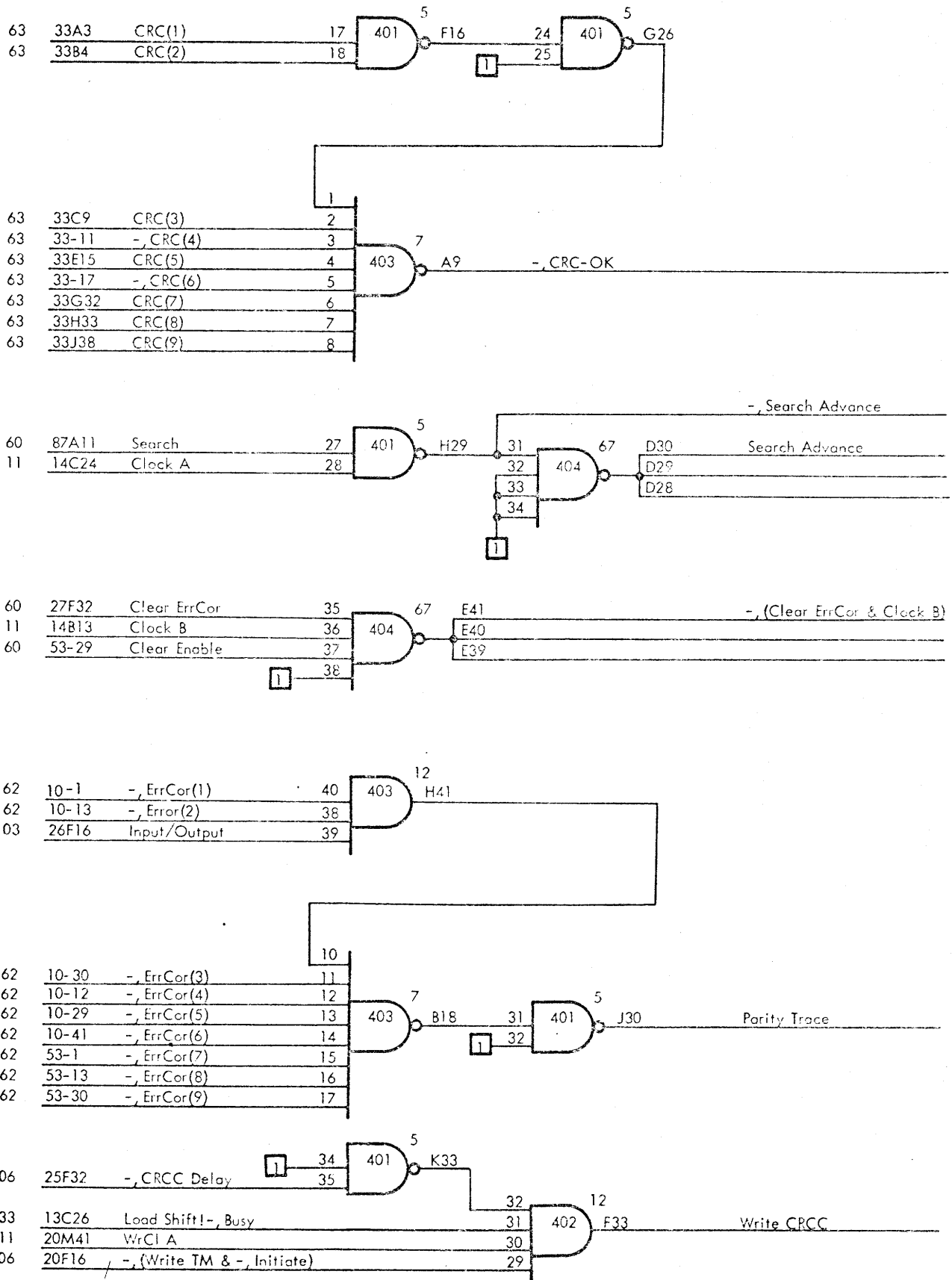

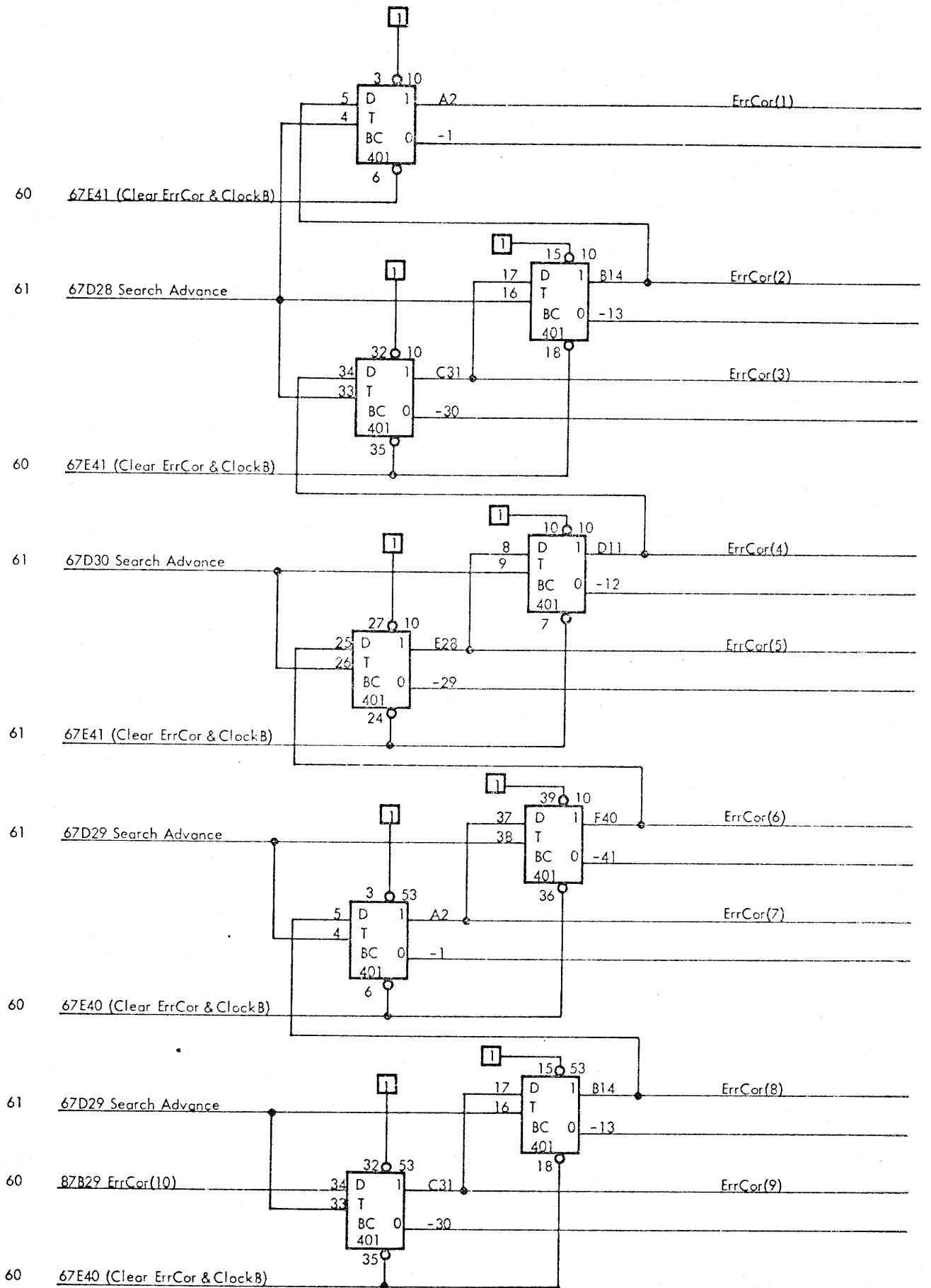

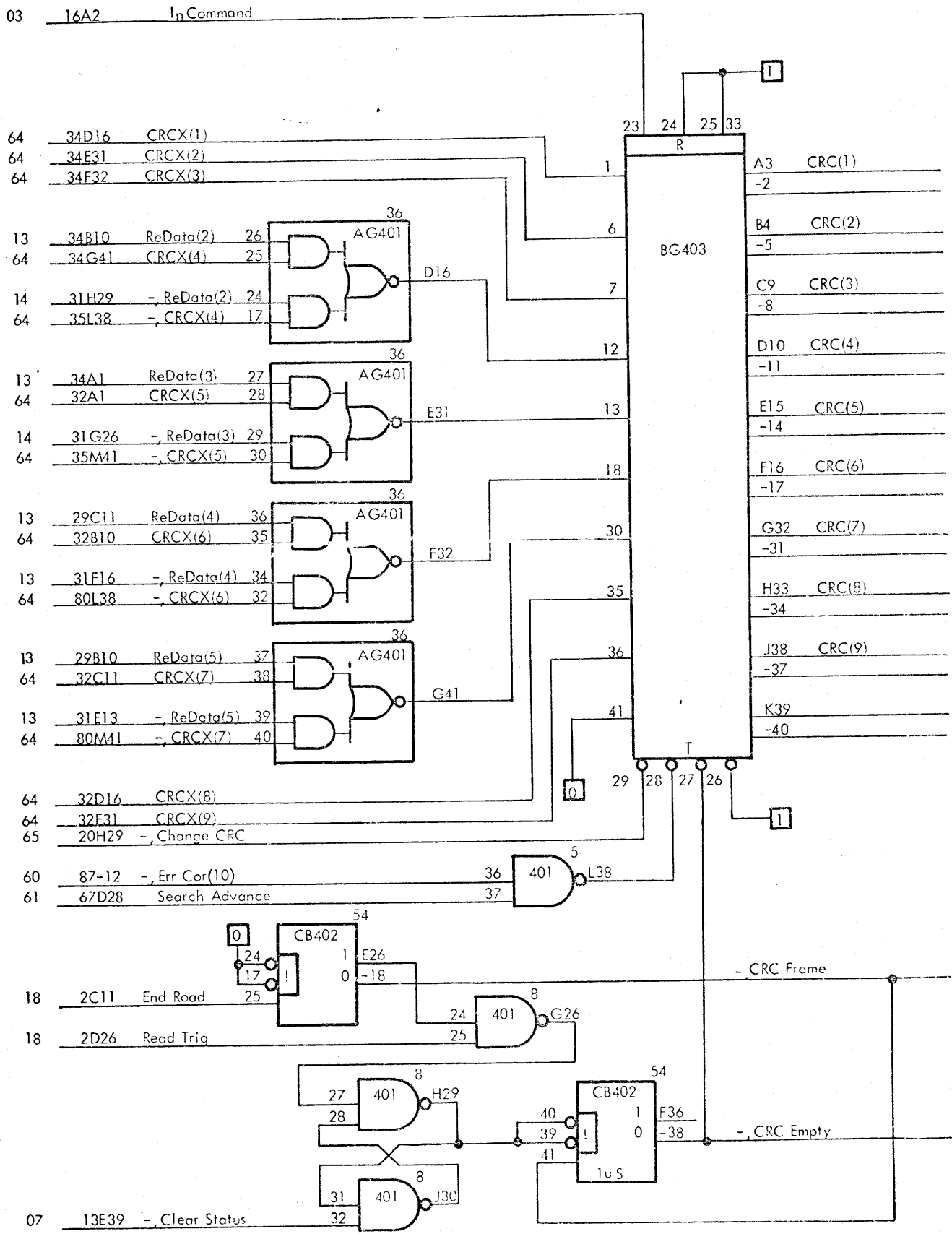



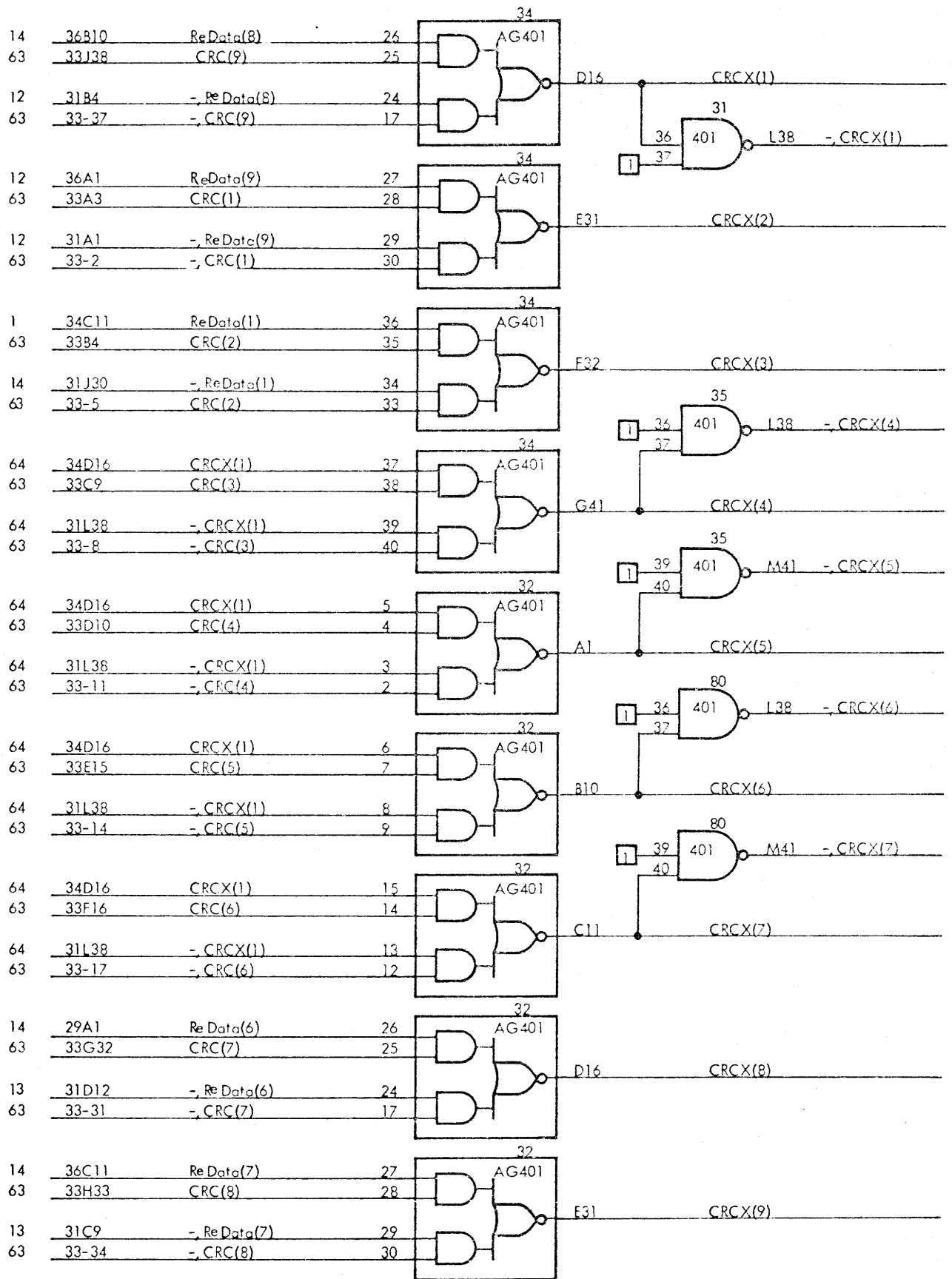

110469J0G 010570HA 500710 KIC 170870 J0G V11312

