

Bang & Olufsen

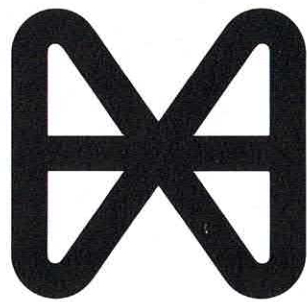

HX PRO

Understanding Beocords II Beocord 9000

This booklet is a continuation of the earlier published product description of Beocord 8002 with HX professional.
 The basic description also applies to Beocord 9000 and in this booklet only the functions which have been added or which function in another way will be mentioned.
 Beocord 9000 has e.g. also HX professional and switch for MPX filter.

Contents

Computer Controlled Calibration	3
New double tape head	7
Azimuth	9
Peak Program Meter	11
Dolby C noise reduction system	14
Automatic demagnetizing	20
Time calibration	21
Capstan system	23
Motor system	24
Power cut	25
Changed specifications	26

BEOCORD 6000-8000-8002

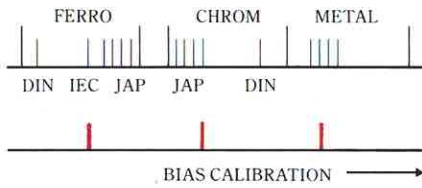

Bias values are factory-adjusted to current norms for ferro, chrom and metal.

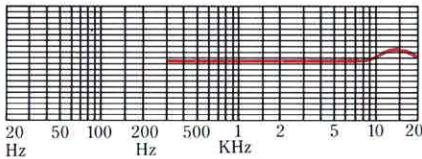

Recording-equalizing in the treble range is factory-adjusted to current norms for ferro, chrom and metal.

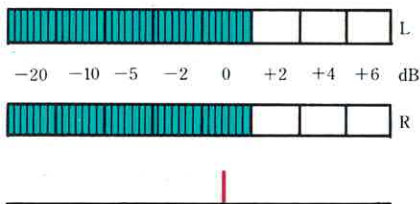

The Peak Program Meter is factory-adjusted to 0 dB = 200 nWb/m, the current norm for tape magnetization.

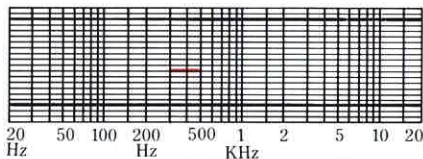

The recording current in the tape head is factory-adjusted to an average level for tape sensitivity in the medium range.

**BEOCORD 9000
COMPUTER CONTROLLED CALIBRATION**

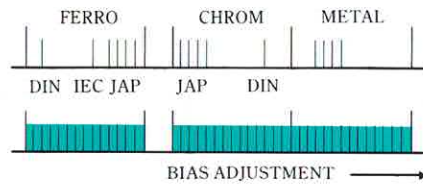

The Beocord 9000 covers the entire bias range, by means of an automatic adjustment to the particular tape inserted. Adjustment is in 0,5 dB steps.

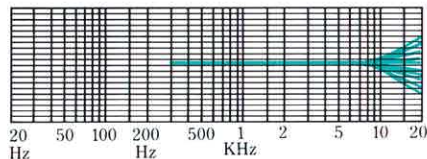

The Beocord 9000 measures the tape's treble sensitivity and adjusts recording-equalizing to the individual tape in steps of 0,5 dB.

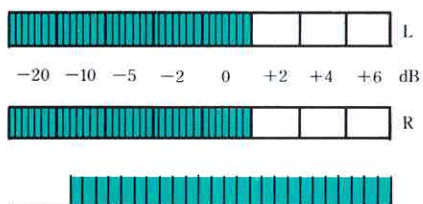

The Beocord 9000 measures the tape's distortion level and uses it as the reference for 0 dB on the Peak Program Meter. Adjustment is in 0,5 dB steps, 30 steps.

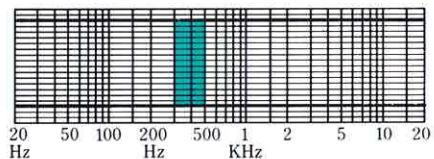

The Beocord 9000 measures the tape's sensitivity in the medium range and adjusts the recording level to that reference (the current through the recording head). Adjustment is in 0.5 dB steps.

COMPUTER CONTROLLED CALIBRATION

A new electronic system automatically adjusts the Beocord 9000's recording functions so as to optimize performance with respect to the specific characteristics of the individual tape.

How are other tape recorders adjusted?

Every tape recorder needs to adjust bias, recording frequency correction and tape sensitivity in order to fully exploit the tape in recording. These adjustments are different for ferro, ferrochrom, chrom and metal tape. Therefore sensor switches are used to ascertain whether a ferro or chrom tape has been inserted, with the help of standardized holes at the rear edge of the cassette. Manual switching is generally used for ferrochrom and metal, because standardization of these cassettes has not yet been carried out for all makes.

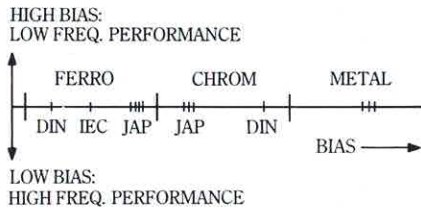

Unfortunately, ensuring the correct values for bias and the other correction functions is not enough.

Within each tape type (especially ferro) there are large divergences in characteristics between different makes. Therefore in designing and constructing the tape recorder it is necessary to decide which make of tape to use in adjusting.

Whichever tape is chosen makes it difficult to accommodate the preferences of various markets for certain makes. And despite IEC efforts to standardize the important parameters, most tape manufacturers still follow their own individual norms.

Also, the adjustments affect each other. For example, choosing a relatively high bias ensures good medium and bass dynamics and low distortion. On the other hand, tape sensitivity in the treble range will be very low, which requires a compensatory adjustment in recording equalizing.

Choosing a low bias raises treble sensitivity, but only at the expense of other tape characteristics.

Automatic calibration and adjustment

The Beocord 9000 features a recording calibration function REC CAL, which automatically measures the individual tape's characteristics and adjusts recording functions accordingly.

The measurement process involves brief, automatic encoding and decoding of pulse tones. The resulting values are used to control the necessary adjustments in the recording amplifier.

The pulse tones are encoded via the double tape head's separate left and right channel recording gaps. Approximately 100 milliseconds later the tape carries these impulses to the other tape head gap, the replay gap, where they are measured and evaluated electronically. If the result is non-satisfactory, an adjustment is made, e.g. in the bias, and a new series of pulse tones are encoded. This process is repeated until the requirements are met. The Beocord 9000 then automatically switches to encoding a different set of impulses and making new adjustments. Calibration continues in this manner until the entire programme of adjustments has been carried out and the Beocord 9000 is ready to record.

The entire process takes about 9 seconds, depending on the type of tape.

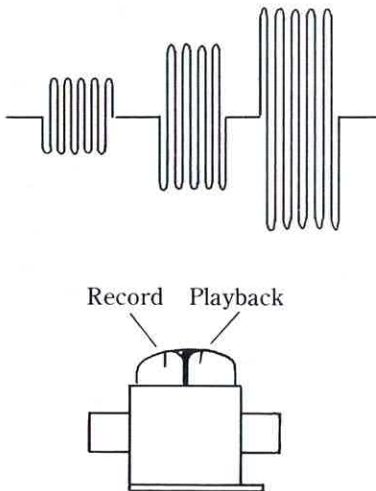

The holes at the rear edge of the cassette are used in the normal way to determine which equalization should be used in playback: 120 µs for ferro, 70 µs for chrom, ferrochrom and metal. At the same time, a provisional bias range is chosen and a tape type indicator lights up.

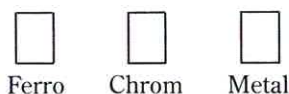

During the subsequent calibration, the indicators register whether the tape has been re-classified to another tape type where it really belongs. For instance, the earliest examples of metal tape will be indicated as chrom at first but switch to metal during calibration.

4

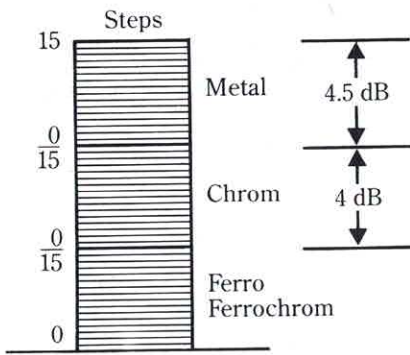

No matter what the holes on the cassette say, automatic recording calibration operates on the information it obtains from its own measuring. If for example a cassette is inserted which is coded as chrom but contains ferro tape, it will be reclassified as ferro in the course of calibration and recorded correctly.

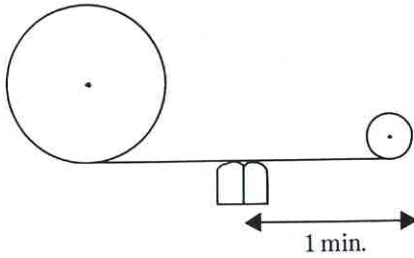

Calibration is at a stable point on the tape. There is a risk of drop-outs and irregularities in the tape coating near each end of the tape; therefore if the tape is fully rewound on insertion, it gets wound past the leader tape, irrespective of length, to a point about one minute from the beginning, where it is calibrated. It is then rewound to the beginning i.e. after the leader tape, and is ready for recording.

All adjustments are independent of the Dolby switch position.

The following parameters are measured and adjusted:

- 1) Bias, right channel.
- 2) Bias, left channel.
- 3) Recording equalization.
- 4) Sensitivity, reference for current flow in the recording head.
- 5) Distortion level, reference for PPM.

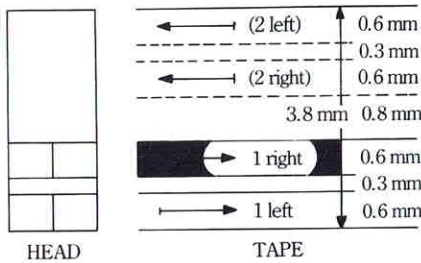

- 1) Bias, right channel

Each channel is calibrated separately; it is not certain that the same bias is appropriate in both cases. First the right-hand channel, which being nearer the middle of the tape has the more favourable operating conditions.

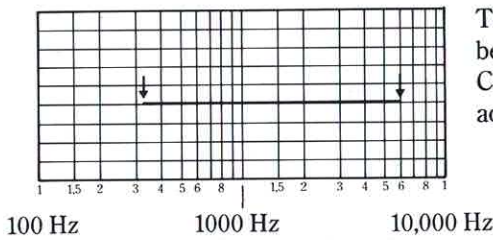

The bias is adjusted automatically until there is linear frequency response between 333 and 7000 Hz.

Calibration is in steps of 0,5 dB, alternating between measurement and adjustment, starting at the highest value in the ferro class. If this is too high,

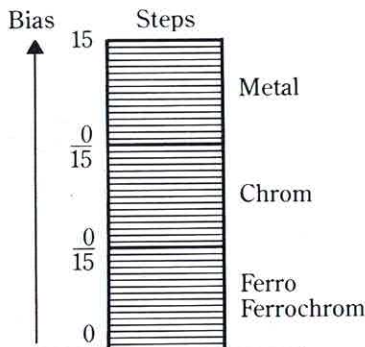

bias is reduced step by step until there is linear response. If it is too low, it switches to chrom and bias is stepped up or down to its proper level. There are 48 steps altogether, 16 for each of the tape types ferro, chrom and metal. Ferrochrom does not constitute a separate type in this context, bias being optimized in the ferro class.

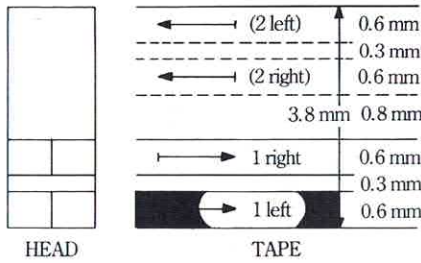

Once bias has been optimized for the right-hand channel, calibration proceeds to

2) Bias, left channel.

Again bias is adjusted to provide linear response between 333 and 7000 Hz. The difference in bias between the two channels will be 3 steps (1.5 dB) at most.

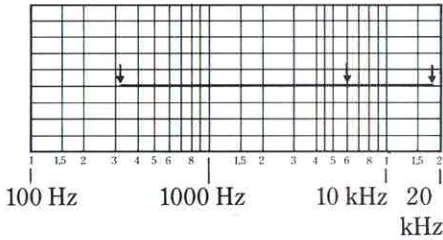

3) Sensitivity, 17,000 Hz

The tape's sensitivity in the treble range is then measured and the recording amplifier equalization adjusted to the level which, in playback, provides the same output signal at 17,000 as in the 333 – 7000 Hz range; in other words linear response throughout the entire frequency range. Calibration starts at the lowest treble lift and is stepped up in units of 0.5 dB. There are 16 steps altogether.

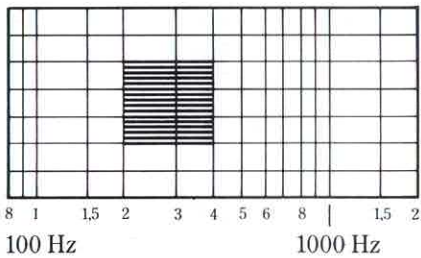

4) Sensitivity, 333 Hz.

Tape sensitivity at 20 dB below 0 dB on the PPM is measured and the recording current through the tape head is adjusted to this reference. Calibration starts with a high current, corresponding to the lowest tape sensitivity, and is reduced in 0,5 dB steps, 15 steps in all.

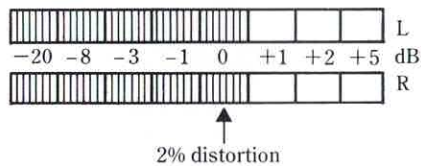

5) Distortion

The tape's signal handling capacity is measured at 333 Hz and the PPM adjusted so that the 0 dB recording level corresponds to approximately 2% distortion. (For technical reasons it is in fact 5% distortion which is used as reference, corresponding to +2/+5 dB on the PPM). With a high quality tape the signal level will be higher than the norm tape's magnetization reference level of 250 nWb/m. 0 dB on the PPM is adjusted to correspond to the specific characteristics of each individual tape irrespective of the tape's quality. Distortion calibration is in 30 0.5 dB steps.

The entire calibration process is now complete and recording can start. All measurements and adjustments are retained in the micro-computer memory during recording-pauses, playback, forward winding and rewinding and on stand by. They are only erased when the cassette is removed by pressing EJECT, or when a different tape type is used.

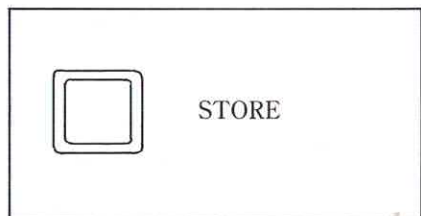

STORE

Using REC CAL for each individual recording gives the best results, and the calibration only takes about 9 seconds. However, this delay can be avoided by using the STORE function to store the calibrated values, on the condition that exactly the same kind of tape is used every time within each category – ferro, ferrochrom, chrom and metal. The STORE function is cancelled next time STORE is used subsequent to a recording calibration, but only for that one tape category. For instance, the ferro calibration can be changed without affecting the information in the ferrochrom, chrom and metal stores.

TAPE TYPE

The tape recorder can be switched manually to different tape categories with the TAPE TYPE button.

However, this is only necessary in the following cases:



- Ferrochrom. At present these cassettes have holes on the rear edge which correspond to ferro, i.e. 120 μ S equalizing in playback. However, better use is made of their characteristics by playing back ferrochrom tapes as chrom, i.e. 70 μ S, as recognized by the latest IEC standard. In this case the TAPE TYPE button is pressed until both ferro and chrom indicators are lit.
- Recording on non-standardized metal and ferrochrom cassettes using STORE, without REC. CAL. TAPE TYPE is pressed until the correct indicator lights up.

315 Hz or 333 Hz

The latest IEC norm used 315 Hz as the reference and measuring frequency. For technical reasons the Beocord 9000 operates with 333 Hz during automatic recording calibration. In this context it is completely irrelevant whether the frequency is 315 or 333 Hz. It is only important in connection with the measuring equipment used in production and servicing.

Checking the calibration stores

Values for the levels to which automatic recording calibration has adjusted the recording functions can be checked on the digital display.

After normal calibration using REC OPEN and REC CAL, STOP and TAPE TYPE are pressed simultaneously.

When the display flashes 00:00, buttons 1, 2, 3, 4 and 5 are pressed and the corresponding values are displayed. The first two digits indicate the value for the adjustment, the last digit is the adjustment code number.

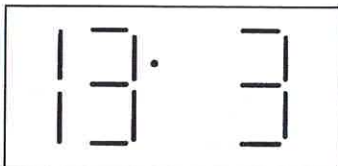

- Bias L, left channel 1
- Bias R, right channel 2
- Recording equalization 3
- Sensitivity 333 Hz 4
- Distortion, PPM reference 5

Here is an example for a ferro tape:

- 11. 1
- 10. 2
- 13. 3
- 07. 4
- 11. 5

The values range from 00 to 15.

- In this example bias for the left-hand channel is one step (0.5 dB) higher than for the right channel.
Values 11 and 10 indicate that this tape is designed for relatively high bias.
- Recording equalizing, 3, gives an indication of the tape's treble sensitivity. The higher the value, the greater the sensitivity, and the less the treble boost required in recording.
- Sensitivity, 4. The higher the value, the greater the tape sensitivity at 333 Hz.
- Distortion and PPM reference, 5. A high value means that the tape can handle a powerful signal at 333 Hz without distortion. The PPM is adjusted to this level so that the REC slider controls can be set higher than with a tape which has a lower value.

REC OPEN
 STOP/TAPE TYPE
 1-2-3-4-5

Readout is in 1 dB steps, 00 to 15. 07 corresponds to a saturation level of 250 nWb/m. This means that the recording of tapes with values higher than 07 can be more intensive than 250 nWb/m, without distortion. The PPM will indicate this in playback, as described in a subsequent section.

Insert a ferro tape and press REC OPEN. Then press STOP and TAPE TYPE simultaneously. Slowly pressing buttons 1 to 5 reveals the information in the ferro store. The next tape type store is checked by pressing TAPE TYPE followed by buttons 1 to 5.

A complete check might give the following results:

Ferro	10. 1	10. 2	12. 3	08. 4	11. 5
Ferrochrom	09. 1	09. 2	13. 3	08. 4	11. 5
Chrom	11. 1	10. 2	13. 3	11. 4	10. 5
Metal	08. 1	07. 2	13. 3	09. 4	11. 5

These digital values should be regarded with a degree of caution. With only 0,5 dB between values, we are operating within the internal limits of the tape. Therefore, the same tape can give different results in the middle, or if we switch side. So these differences are not due to the tape recorder.

The Beocord 9000 is not designed as a tape testing unit, but as a sophisticated tape recorder, which provided the owner the greatest opportunity for getting the maximum out of his/her cassettes.



NEW DOUBLE TAPE HEAD

The Beocord 9000 features a new sendust/ferrite tape head, specially designed for Bang & Olufsen.

It has separate tone gaps for recording and playback, housed in a single casing. Compared to a combination head or completely separate record and replay heads, this arrangement has the following advantages:

- Wider frequency range, 20-25,000 Hz.
- Always the correct azimuth between recording and playback.
- Built into a single casing, positioned opposite the appropriate opening in the cassette.
- Helps provide rapid recording calibration, approx. 9 seconds; recording and playback operate continuously during tape transport.

Both sendust and ferrite

To ensure a high recording level as well as a wide frequency range the new tape head utilizes both sendust and ferrite.

A 3 layer sendust pole shoe is used for recording.

Sendust can handle a high magnetic current before reaching saturation point, so that recording can be made at levels which are higher than the MOL limit of the very best tape on the market. This means that it is not the tape head which places the distortion limit on recording.

The recording gap is relatively wide, 2.5 μm . This provides the deep tape magnetization required for improving low frequency dynamics. The width of the recording gap is non-critical with respect to high frequencies in recording.

Playing back frequencies as high as 25,000 Hz requires a narrow tape head gap and a small eddy loss. Under these conditions ferrite is better than sendust, being a ceramic substance which does not conduct electricity.

The width of the ferrite replay gap is 1 μm .

Sendust and ferrite are both very hard materials which are very durable compared to super permalloy.

The contact surfaces above the pole shoes for the left and right channels also use sendust for recording and ferrite for playback.

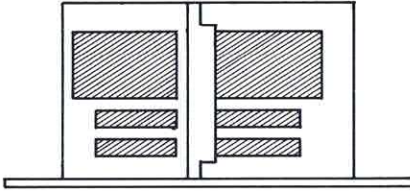

Sendust and ferrite are both very hard materials which are very durable compared to super permalloy. The contact surfaces above the pole shoes for the left and right channels also use sendust for recording and ferrite for playback.

Recording saturation	Ferrite	Super Permalloy	Sendust
Playback frequency range	Sendust	Super Permalloy	Ferrite
Permeability	Ferrite	Super Permalloy	Sendust
Durability	Super Permalloy	Sendust	Ferrite

highest performance. →

This table summarizes the relative performance characteristics of the materials used in modern tape head pole shoes.

New playback amplifier

Ferrite is less permeable than sendust which means that the signal voltage in playback is slightly lower.

Therefore the Beocord 9000 is designed with a special low-noise playback amplifier, incorporating special low-noise Field Effect Transistors, rated to extremely high performance specification.

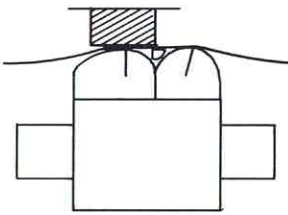

Contact between tape and tape head gaps

With a combination head there is no great problem in keeping the tape pressed against the tape head. There is only the one contact surface, opposite the cassette's felt pad.

With separate recording and replay heads there are two contact surfaces, but still just one felt pad. This is one of the reasons why a number of manufacturers use double capstans to get a satisfactory contact for each of the two heads.

The Beocord 9000's double head is positioned so that the felt pad presses against the recording gap. As the replay gap is between the felt pad and the capstan, the tape is under constant tension.

This keeps it in continuous contact with the replay gap as well, so that there is no need for a double capstan in the Beocord 9000.

Automatic recording calibration

In tape transport, the tape passes the recording gap first and then the replay gap. These operate alternately in recording calibration, recording and playing back a series of pulse notes for a period of about 9 seconds. With a combination head this period is protracted and the procedure entails winding the tape backwards and forwards several times.

Off-the-tape monitoring?

In dealing with two tape head gaps, we are bound to face the familiar question of off-the-tape monitoring in recording.

The answer is that the Beocord 9000 has »internal monitoring«, but not what is generally understood by off-the-tape monitoring.

There are a number of reasons for this decision. We can start by looking back at the origins of monitoring.

Off-the-tape monitoring originated in reel-to-reel tape recorders, where there are no restrictions imposed by a limited number of openings as on the front of

a cassette; so that in principle any number of tape heads can be placed along the tape path. This makes a variety of functions available: 2 and 4 track, mono and stereo, echo and sound on sound, where recordings are directed from one track to another. Off-the-tape monitoring is provided almost gratuitously, both for checking which channels are mixed and whether the signals are recorded powerfully enough while remaining free from distortion. It is especially the latter facility which a number of manufacturers have applied to cassette tape recorders.

In our opinion, the cassette recorder is a quite different product, designed for private domestic use, where the emphasis should be on high sound quality and simple operation and not require the user to play the role of sound technician. There are two other considerations which make off-the-tape monitoring unrealistic as far as the Beocord 9000 is concerned:

- Modern Peak Program Meters provide such precise readings that using them as visual controls is more reliable in checking recording distortion than an aural control.
- As we know, Dolby noise reduction is used both in recording and playback, and exactly the same electronic circuits are involved in both operations. Proper off-the-tape monitoring would require twice as many Dolby circuits. In the case of Dolby C, which already has twice as many circuits as Dolby B, this would mean a considerable increase, both in regard to price and the space required within the tape recorder.

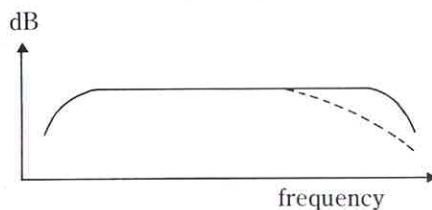

AZIMUTH CALIBRATION

Briefly, azimuth is the play head's alignment with the signals recorded on tape. This is one of the most significant factors in tape recorder performance, directly affecting treble reproduction. Imperfect azimuth results in audible treble loss; consequently it is particularly important that we ensure the optimum adjustment in a tape recorder which can handle frequencies right up to 25,000 Hz. We can regard azimuth adjustment in the light of two different sets of circumstance:

- 1) Recording and playing back on the same tape recorder
- 2) Playing back a tape recorded on another tape recorder.

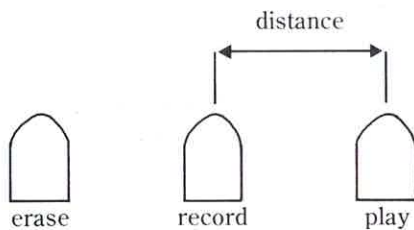

- 1) Tape recorders boasting high specifications need to have one head for recording and another for playback. In the case of completely separate record and play heads (discrete 3 head system) there is of course a certain distance between these heads.

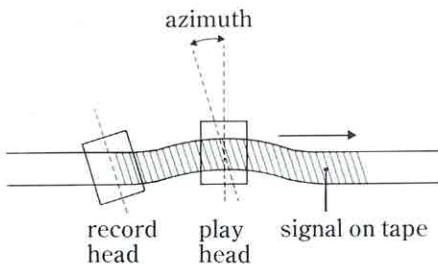

This means that the azimuth has to be readjusted for every single tape to get the best possible result, because the tape twists slightly in moving from the record to the play head.

A number of tape recorders of other makes require a manual or automatic adjustment to be made to the record head prior to each recording.

The diagram illustrates this problem in an exaggerated form.

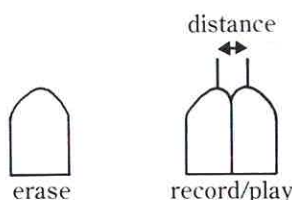

If on the other hand both the record and play heads are housed together, the distance between them becomes so small that the tape cannot twist, which makes these frequent readjustments unnecessary.

- 2) In the second case, the tape has already been recorded on another tape recorder. If this other recorder's azimuth was not properly adjusted, there will be a loss of treble when the tape is played back on the Beocord 9000, which means that we have to adjust the Beocord's play head to this particular tape.

We also have to restore the original (proper) factory-adjusted azimuth before again recording on the Beocord 9000.

This requires some sort of measuring device, and the Beocord 9000 provides one.

Individual azimuth tape with every Beocord 9000

An azimuth adjustment tape in a special cassette with a metal casing is supplied with each Beocord 9000.

The background for this solution is as follows:

- In the course of production, the Beocord 9000's tape head azimuth is adjusted with the aid of a full-width test tape which has been recorded on professional equipment under strict laboratory control.
In making the adjustment, the relevant tolerances – frequency response, phase, channel matching – are monitored with respect to the tape head.
- A tape which is in principle an exact copy of the test tape is then made on the individual tape recorder, by recording a high frequency (12.500 Hz) on both tracks. This tape goes with this particular tape recorder and has the same serial number.
- Subsequently, whenever the owner wishes to readjust his Beocord 9000 he can do so very simply but just as accurately as in factory adjustment, just by reading off the Peak Program Meters.
The owner cannot use a standard full-width azimuth tape as the factory does, because special measuring instruments are needed in order to get the best result.

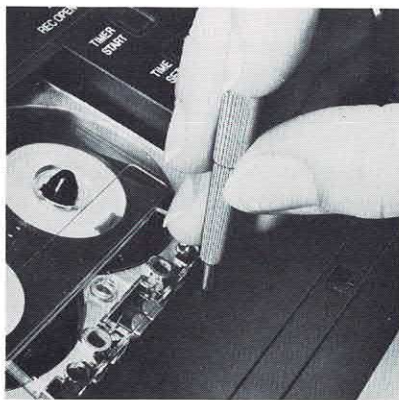

How is the azimuth tape used?

It is very simple: insert the cassette and start playback with > .

Insert the anti-magnetic screwdriver provided in the hole in the cover plate, and turn the screw on the right of the tape head until the PPM gives the maximum reading. The screw may be turned clockwise or anti-clockwise, but not more than one revolution. Meter readings do not have to be identical for both channels.

When is the azimuth tape used?

In two situations:

- To compensate for any variations which may arise in the course of normal running, we recommend checking the azimuth every 6 month.
- If the azimuth has been adjusted for playing back tape recorded with the wrong azimuth on another tape recorder: readjust with the aid of the azimuth tape before again recording on the Beocord 9000.

PEAK PROGRAM METER

In recording

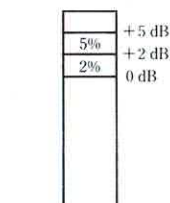
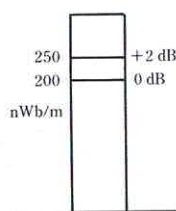

VU meter readings on most tape recorders are adjusted with reference to a standardized tape magnetization level. This includes the Beocord 8002, where $200 \text{ nWb/m} = 0 \text{ dB}$, and $250 \text{ nWb/m} = +2 \text{ dB}$. However this magnetization level is not directly related to the tape's distortion level; with high quality tape, which has a high signal handling capacity, distortion first appears at a much higher magnetization level, while with tape of inferior quality, distortion occurs at a lower magnetization level.

The Beocord 9000's Peak Program Meter is designed so that 0 dB corresponds to 2% distortion in the recording of any given tape. (Between $+2 \text{ dB}$ and $+5 \text{ dB}$ there is 5% distortion). This can be done because REC CAL ensures exactly the right bias for a given tape, and HX Professional makes sure that this bias value is kept constant under dynamic conditions. The reference used for distortion depends on the tape concerned. It is automatically adjusted for the individual tape during recording calibration. In this way we get very close to the limit for the tape's signal handling capacity and can take full advantage of this capacity.

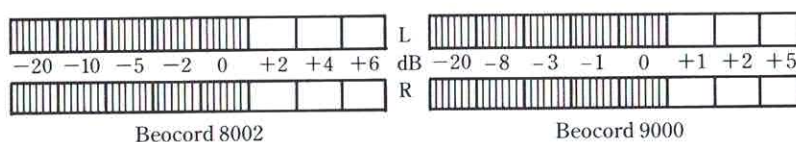

The Beocord 9000's PPM has a new scale, with smaller dB graduations around 0 dB providing a more precise readout.

The 0 dB reading applies to all types of tape in recording.

Thus the Beocord 9000's PPM is not meant to give readings continuously in the red zones, which is acceptable in the Beocord 8002 with metal tape. For the 9000 such reading would produce measurable distortion.

As far as recording is concerned we can state:

- High quality tape, high signal handling capacity, PPM 0 dB .
- Inferior quality tape, lower signal handling capacity, still PPM 0 dB .

Peak Program Meter in playback

In playing back these tapes the PPM readout will be somewhat different, giving a real indication of what the tapes can handle:

- High quality tape, PPM $+1$ to $+5 \text{ dB}$.
- Inferior quality tape, PPM 0 dB or below.

This is because the PPM uses a playback reference which corresponds to a fixed magnetization level ($+1 \text{ dB} = 250 \text{ nWb/m}$, $-1 \text{ dB} = 200 \text{ nWb/m}$). This is the case when REC OPEN is cut out, i.e. the indicator light is off.

If on the other hand a tape is played back immediately after being recorded, with REC OPEN still cut it, the PPM continues to use the recording reference, i.e. the distortion level. In this case the readout indicates how close to the distortion limit the tape has been recorded.

Thus the PPM can be switched to one of two references during playback:

- $0 \text{ dB} = 2\%$ distortion, REC OPEN on.
- $+1 \text{ dB} = 250 \text{ nWb/m}$ signal handling capacity, REC OPEN off.

BEOCORD 6000-8000-8002 PEAK PROGRAM METER

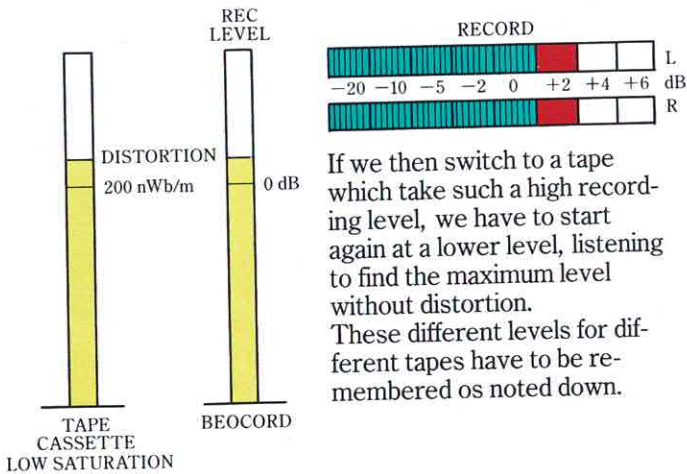
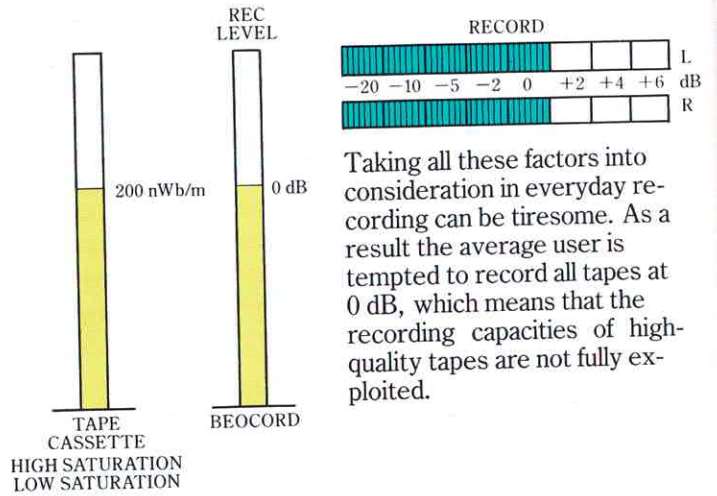
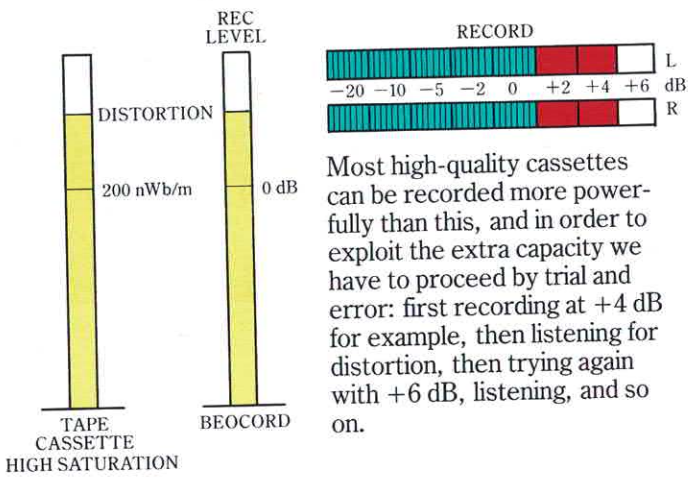
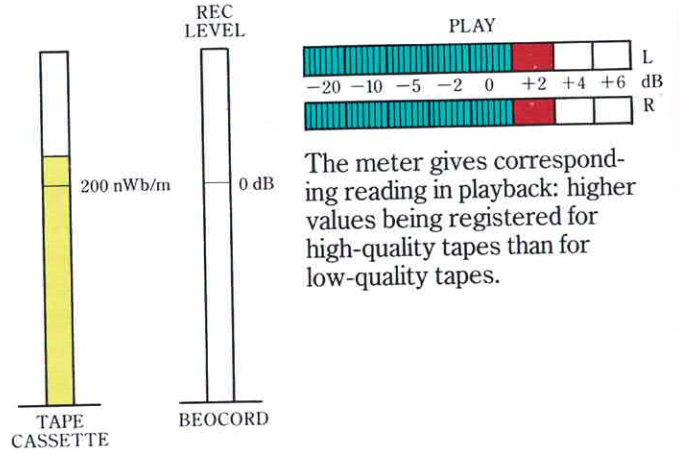
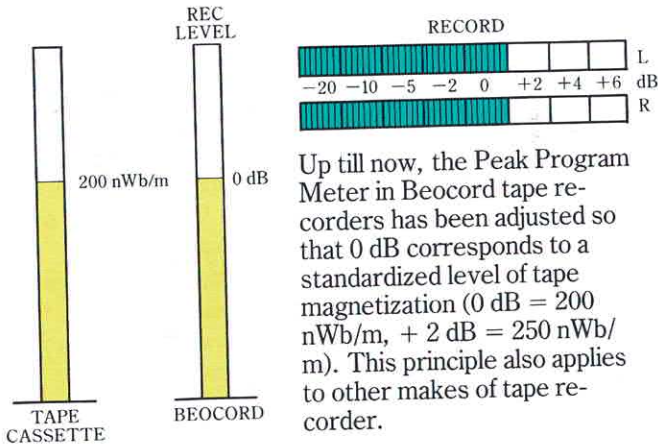

**BECORD 9000
PEAK PROGRAM METER**

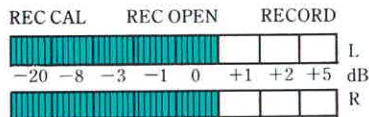
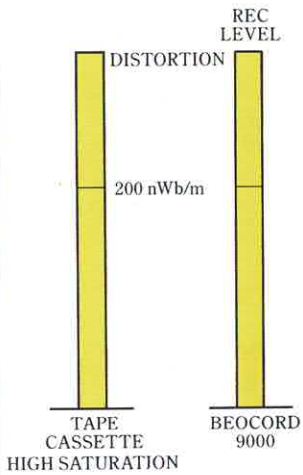

The Beocord 9000 solves this problem by means of automatic recording calibration. The Peak Program Meter reference is not a standard value, 200 nWb/m, but the specific distortion levels for the particular tape inserted. This level is highest for high-quality tapes, and allows us to record at the optimum level without first having to find it by trial and error.

All we need to do is read off to 0 dB on the PPM on in adjusting the REC controls. Moreover, the + and -dB graduations are smaller than on previous Beocord models, providing more precise readings.

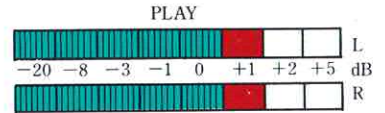
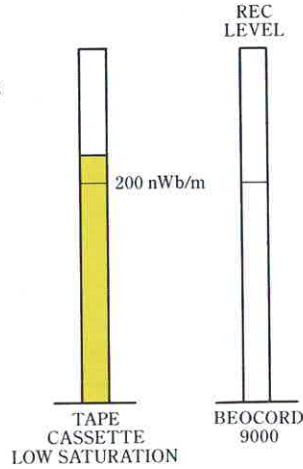

Tapes recorded at lower levels produce lower readings in playback, but full use is still made of their characteristics.

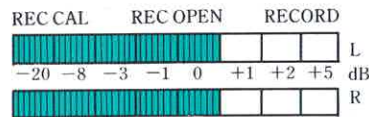
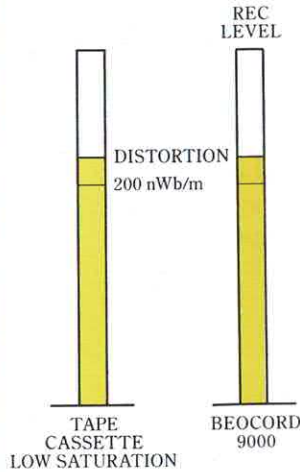

For inferior quality tapes the distortion level is lower, but the optimum recording level is still at PPM reading 0 dB, as recording calibration adjusts the PPM to the specific characteristics of the tape.

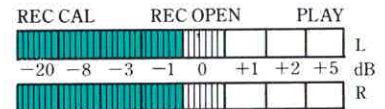
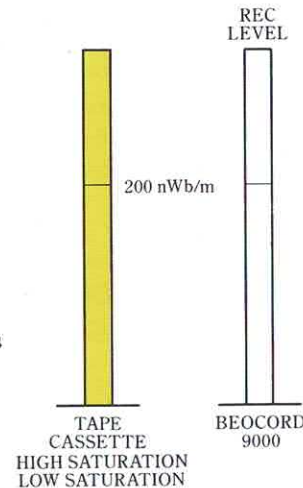

If a tape is played back with REC OPEN on, e.g. immediately after recording on that same tape, PPM readings for both high- and low-quality tape will be slightly below 0 dB, as the PPM still refers to the recording calibration.

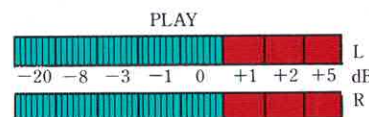
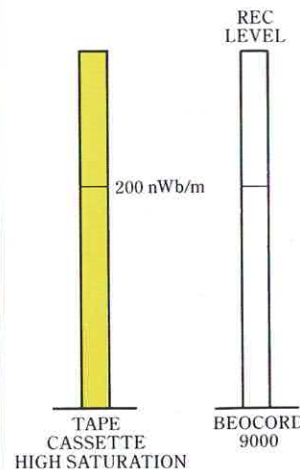

When tapes are played back in the normal mode (i.e. REC OPEN indicator off) the PPM is switched to the standard reference, 200 nWb/m. This enables a direct comparison of how powerfully different tapes have actually been recorded; high-quality tapes will produce readings considerably above 0 dB without distortion.

So there is nothing wrong when the PPM gives readings way up in the red zones during playback.

On the contrary, it proves that the Beocord 9000 makes optimum use of every type of tape and does it better than most other tape recorders.

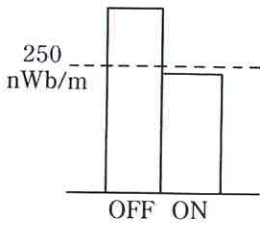

Here we see a high quality tape which has a higher signal handling capacity than the norm tape's 250 nWb/m. PPM readout is greatest with REC OPEN off.

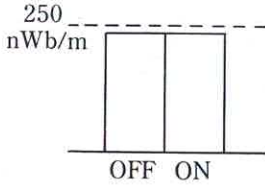

If we use a tape which has 3% distortion at 250 nWb/m magnetization, readings will be identical with REC OPEN on or off.

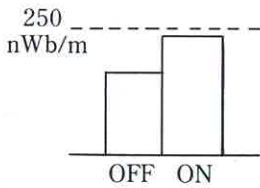

If the PPM reading is lowest with REC OPEN off, it means that the tape cannot handle 250 nWb/m without distortion exceeding 3%. This does not prevent the tape from having good performance characteristics in other areas.

Peak Program Meter and Dolby noise reduction

In the case of recordings made with Dolby C or Dolby B noise reduction, the PPM reading 0 dB still corresponds to 2% distortion. Automatic recording calibration is designed so that PPM readings are identical for all 3 Dolby switch positions.

DOLBY C NOISE REDUCTION SYSTEM

The Beocord 9000 incorporates Dolby C, which is a 20 dB noise reduction system.

In comparison, the present Dolby B (Dolby NR) system provides a 10 dB reduction in tape hiss. The Beocord 9000 is fully compatible with tapes recorded using Dolby B: it can be switched to Dolby C, Dolby B or OFF. In principle, two Dolby 10 dB systems are used, both in recording and in playback. When both systems are cut in simultaneously, the result is Dolby C.

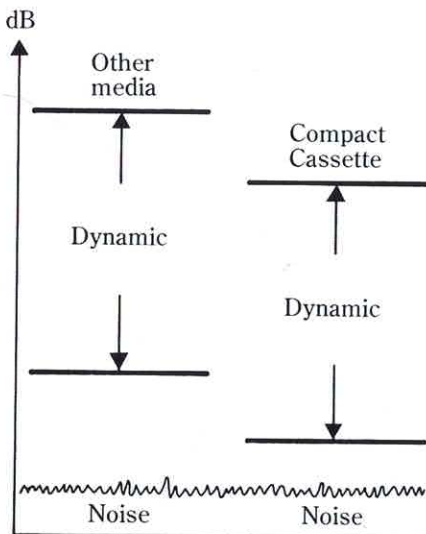

Dolby B: a brief summary

One of the problems of the Compact Cassette system is that the low tape speed and narrow tape track place a limit on how powerfully the tape can be recorded. Thus the level of a given dynamic range – the relationship between the loudest and the weakest sound passages – has to be lowered to prevent the loudest notes from causing overload and distortion. Consequently, the quietest passages and pauses in the sound signal are brought down within critical proximity of the tape's self-noise, which produces an audible hiss during playback.

One of the possibilities for reducing tape hiss is to incorporate a noise reduction system in the tape recorder. There are a number of systems; the most widely used have been developed by the Dolby Laboratories in the USA. Dolby A is a professional system, one of the applications of which is in reel-to-reel recorders in studio recording and cutting records. Dolby A operates throughout the entire audio frequency range, but splits it into four bands which are handled individually. This makes Dolby A very complicated and very expensive.

Dolby B is a simplified version which for a number of years has been used in cassette recorders under the name of Dolby NR (Dolby Noise Reduction).

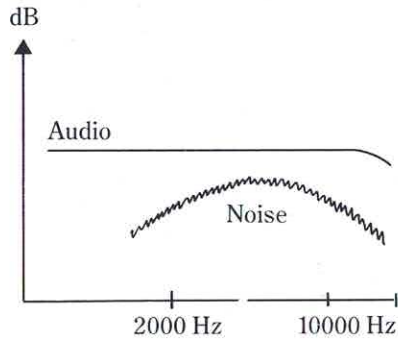

Dolby B is based in the fact that audible tape hiss has a sound characteristic which corresponds to a limited section of the treble range. Audio tests show that the human ear is most sensitive to noise in the range of approx. 2000 to 10,000 Hz. This means that tape hiss is most noticeable with quiet treble notes in this frequency range and when there are pauses. Powerful treble notes drown the tape hiss, so that noise reduction is superfluous in their case. Simply damping the 2000 – 10,000 Hz range during tape playback would mean that the level of treble notes was reduced in relation to the rest of the frequency range. Non-linearity of this kind is unacceptable in high-fidelity reproduction.

Therefore Dolby B is designed as a compressor/expander system which operates both in recording the cassette and in playback.

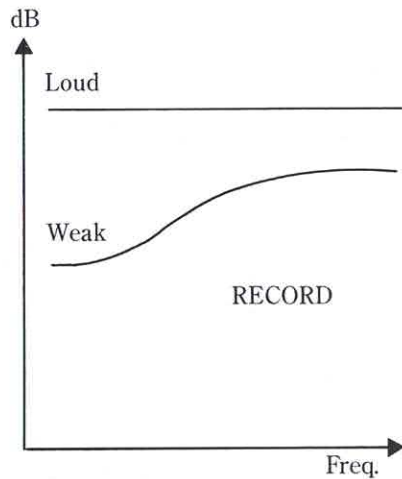

In recording, the treble range dynamics are compressed, so that the loud treble notes maintain their original level, whilst the treble content of quiet passages is raised. These notes are fed to the tape head with the rest of the audio signal and recorded on the tape.

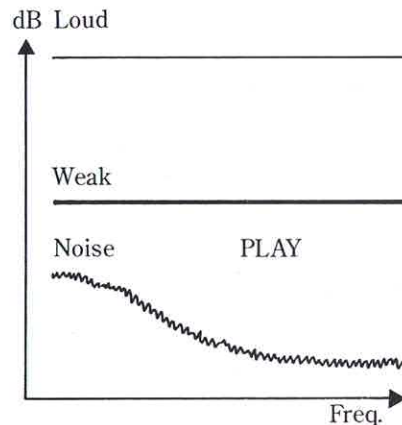

The process is reversed during playback. An expansion takes place in the treble range, restoring the weak treble passages to their original level without affecting the powerful treble notes. In this way the original dynamic range is re-created.

But the most significant aspect of this process is that there is a corresponding reduction in tape hiss during the quiet treble passages, approx. 10 dB. Because the level of tape hiss is not raised during recording; it only enters the picture when the cassette is played back.

If on the other hand the program source – record, FM broadcast or another tape – contains hiss or noise, this is not removed or reduced by Dolby B, as it too is boosted during recording along with the weak treble notes.

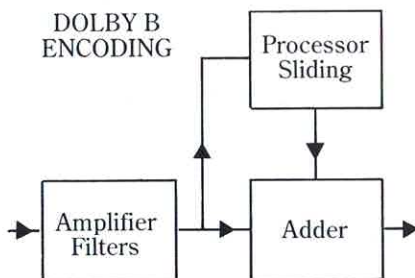

Dolby B only operates in the treble range, on the sliding band principle. This means that the frequency or frequency band at which the system starts to function is not fixed, but varies according to the necessity for noise reduction. The weaker the treble notes, the lower the frequencies at which the system starts to function.

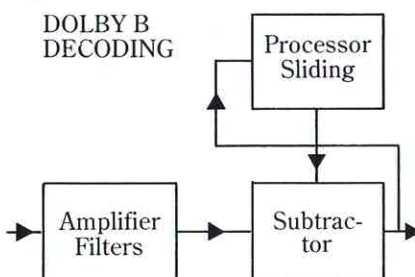

The electronics of Dolby B consists of IC's which are constructed specially for this purpose. The processor itself is used both in recording and playback, but with reverse functions.

In recording the circuit is connected as an encoder, in playback as a decoder. There are separate circuits for the left and the right channel.

Dolby C

Dolby C is a 20 dB sliding band noise reduction system.

It operates on the same principle as Dolby B, but with significantly greater noise reduction. In principle, two Dolby circuits are used both during recording and playback.

In the Beocord 9000 the system is designed so as to make it possible to switch to Dolby B, where one circuit is connected, or to Dolby C, where both circuits are cut in.

This ensures perfect compatibility with cassette tapes recorded with Dolby B. The natural question to ask is why can't this be done all at one go, for example by increasing the effect of a Dolby B system?

There are certain limitations as to how large a regulating range a single process can handle with positive results. If these limits are exceeded, there are various negative side-effects – pumping and transient distortion, for example.

Pumping is a result of sudden changes in signal level, causing variations or holes in the sound until the signal finds its proper level. As for transients – short-lived jumps in the audio-signal – their rise and fall times must match each other during recording and playback. All these conditions are best met by keeping the regulating range within 10 dB and repeating the process instead.

In recording, the audio signal first passes through a high level function, a Dolby processor. After that comes a low level processor, which handles the quietest treble notes, boosting them before the signal is recorded on the tape. When both processors are in operation, the sliding frequency is approximately two octaves lower than with Dolby B for a given signal level.

For instance, a weak signal level with Dolby C gives a noise reduction of 10 dB at roughly 200 Hz, while Dolby B gives a 5 dB reduction at about 800 Hz.

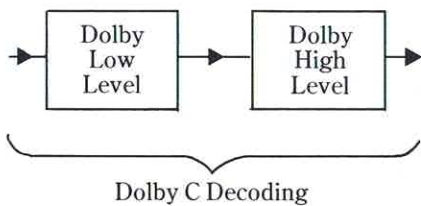
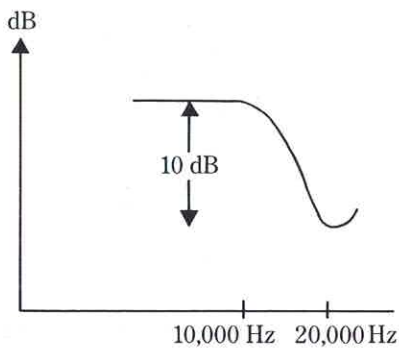
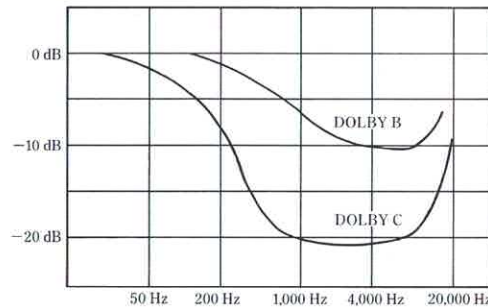
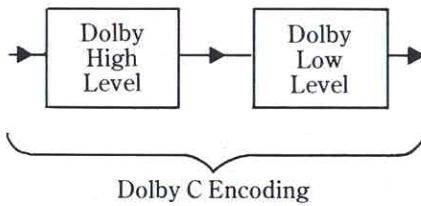

Here the degree of noise reduction is shown graphically where there is only one frequency at a given time. If there are several simultaneous frequencies, the picture is more complicated.

In that case the curves are moved up to higher frequencies, because there is less need for noise reduction when the human ear is subjected to a number of influences at the same time (the screening effect). Steps have also been taken to ensure that the tape's MOL curve is not exceeded as a result of the 20 dB total regulating range. A filter placed just before the high level processor gradually attenuates the signal, with a fall of approximately 10 dB at 20,000 Hz.

In playback the signal path is reversed, passing through the low level processor first and then the high level. A filter with the inverse function of the one described above raised the loudest treble notes to their original level. This means that noise reduction at 20,000 Hz is not 20 dB, but approximately 8 dB. However, this is unimportant, as human hearing is less sensitive to noise signals at 20,000 Hz than it is within the 2000 - 10,000 Hz range.

These adjustments in the treble range must not be confused with normal 70 or 120 μ s equalizing, which continues to function as before and is independent of Dolby C.

Why not use wide-band noise reduction?

As stated previously, Dolby C is a sliding band noise reduction system.

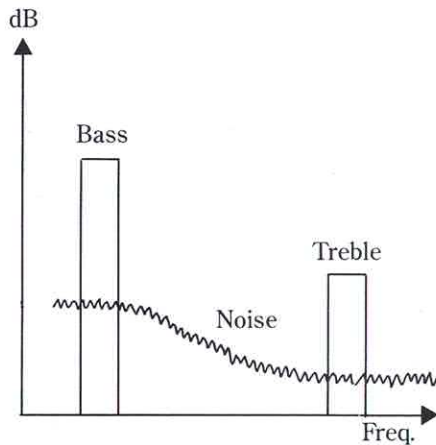
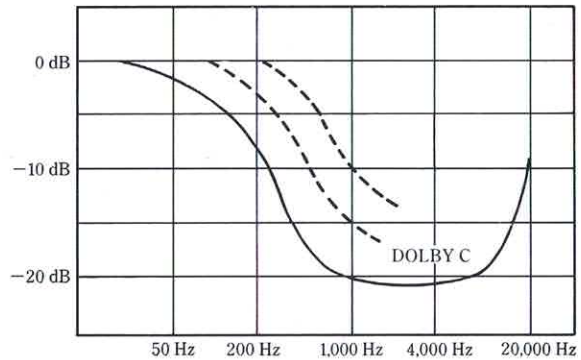

Here the continuous line shows the maximum noise reduction attainable with Dolby C, assuming the absence of simultaneous audio signals. Optimum noise reduction is maintained right down to 1000 Hz, after which it gradually falls to 0 dB below 50 Hz.

When audio signals occur at the same time, the curve is moved up to higher frequencies, represented by the dotted lines. Furthermore, the degree of noise reduction decreases as the audio signal level rises.

If, for example, a bass note occurs at the same time as a weak treble note, Dolby C starts to function, providing noise reduction in playback.

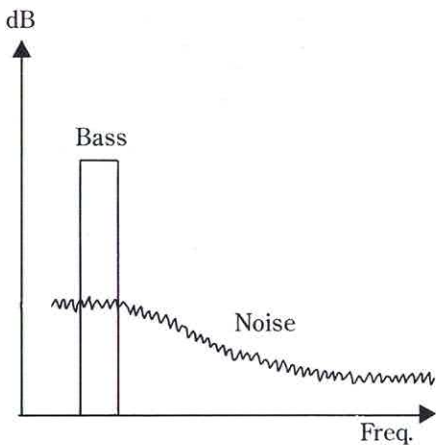

The same thing happens when there is only the bass note and no treble.

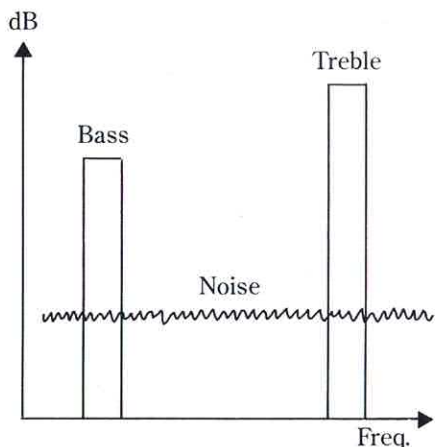

If on the other hand the treble note is loud, there is no noise reduction.

Because during playback, the ear registers the treble note and not the hiss, as both operate on the same section of the sound spectrum. This holds true even if we concentrate on listening to the bass note (the screening effect).

A wide-band system reduces throughout the full frequency range. In some systems this is done by a single process, in others the process is split into two sub-bands.

We have carried out a number of audio-tests, comparing Dolby C and various wide-band systems of different makes.

Our experience is that there are acoustic side-effects with a number of the wide-band systems, particularly in connection with bass notes.

When listening to audio-tests, pay particular attention to the following points: Listen closely to whether there is any modulation or variation in the audible noise level in conjunction with the level of bass volume; this includes rumble in recordings of gramophone records.

Note too whether there is any treble cut-off.

Excessive treble boosting during recording violates the tape's MOL limit, which leads to muted treble playback.

New input amplifier

In order to make the most of the sizeable noise reduction, all the other electronic components and systems in the tape recorder must conform to such high specifications that they do not place limitations on this result.

Therefore the Beocord 9000's input amplifier has been modified. It contains new components compared to previous models and has a signal-to-noise ratio in the region of 90 dB.

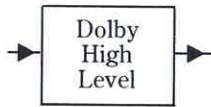

Dolby B Encoding

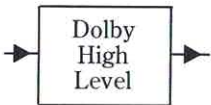

Dolby B Decoding

Compatibility, Dolby C and Dolby B

The Beocord 9000 provides complete compatibility between Dolby C and Dolby B:

- Tapes which have been recorded on another tape recorder using Dolby B can be played back on the Beocord 9000.
- Tapes can be recorded on the Beocord 9000 with Dolby B for playback on other tape recorders.

Switching to Dolby B simply means confining recording and playback to the high level processors.

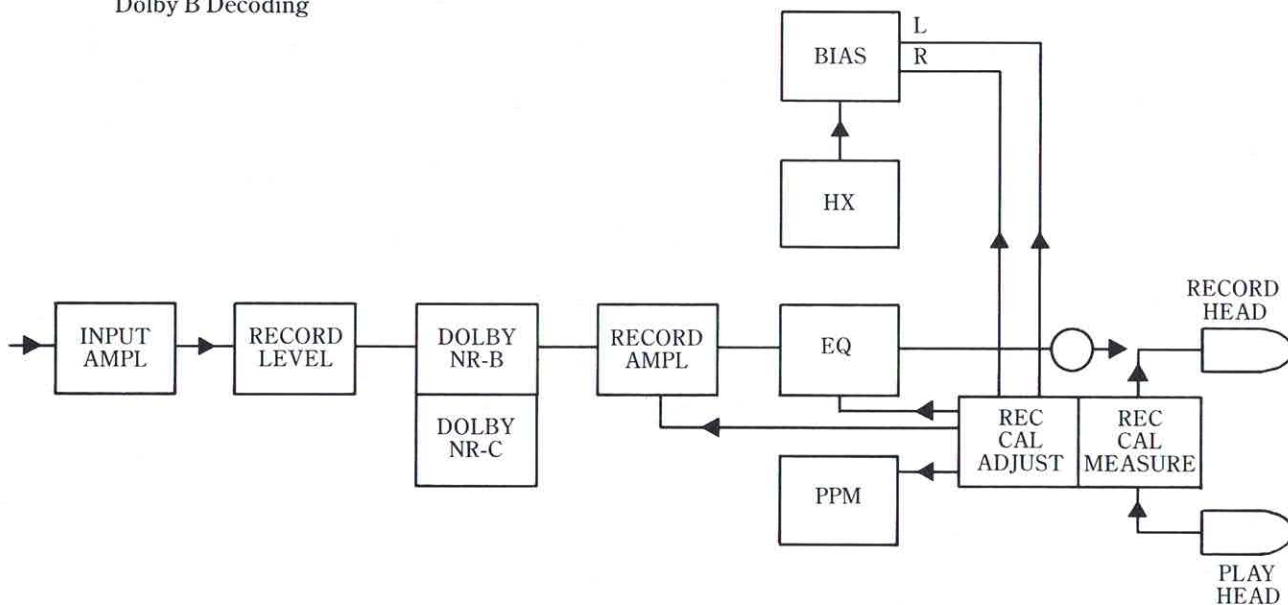

Dolby C and HX Professional

These function completely independently, but indirectly they help each other:

- HX Professional »raises the ceiling« by making better use of the tape's signal handling capacity. With the recording level raised, Dolby C is in operation for shorter periods of time than it would be without HX Professional.
- Dolby C »lowers the floor« by reducing tape selfnoise when necessary, during very quiet passages and in pauses.

Dolby C and the Peak Program Meter

The PPM also helps make the most of the Dolby C system. It measures the audio-signal after noise reduction, and as this reading will be slightly lower with Dolby C than with Dolby B or OFF, it permits a higher recording level. Consequently, a special Dolby reading on the PPM scale is superfluous.

With which type of tape is the improvement greatest?

Dolby C provides a very noticeable noise reduction on all types of tape, including metal. The greatest improvement is with the noisiest ferro tapes; the degree of improvement falls as the quality of the tape rises, through low-noise ferro tapes to chrom to metal, which has the least room for improvement.

What happens if the wrong noise reduction mode is used?

Recorded with Playback with	Dolby C	Dolby OFF
Dolby C	Correct	Very dull sound. Sudden changes in volume; only loud passages come across.
Dolby OFF	Very sharp sound. Hiss which is only suppressed during loud passages.	Correct

Dolby C operates both in recording and playback. If operated incorrectly, e.g. by playing back a Dolby C recording without Dolby C connected or vice versa, the reproduction suffers some kind of distortion.

Recorded with Playback with	Dolby C	Dolby B	Dolby OFF
Dolby C	Correct. Max. noise reduction 20 dB.	Dull sound. Quiet treble passages even quieter.	Very dull sound. Sudden changes in volume; only loud passages come across.
Dolby B	Sharp sound. Treble dynamics too low, treble notes too loud.	Correct. Max. noise reduction 10 dB.	Dull sound. Quiet treble passages even quieter.
Dolby OFF	Very sharp sound. Hiss which is only suppressed during loud passages.	Sharp sound. Treble dynamics too low, quiet treble notes too loud.	Correct. No noise reduction.

We get a more detailed picture by including Dolby B as well.

In principle there is nothing new in having the user cut Dolby in or out. There is no automatic switching with the aid of holes in the rear edge of the cassette, and there has not been in all the years that cassette recorders have used Dolby B. The introduction of Dolby C increases the necessity of selecting the correct Dolby switch position:

- The degree of noise reduction is larger and therefore of greater importance.
- There will probably be more tape recorders with Dolby B than with Dolby C in the next few years, on account of the price.

If tapes are recorded on the Beocord 9000 solely for playback on a Beocord 9000, there is no problem; Dolby C every time.

If tapes are swapped or loaned, or recorded for playback elsewhere (e.g. on a car tape deck), one has to think twice, then usually switch to Dolby B. Which is why the Dolby switch has three different positions.

AUTOMATIC DEMAGNETIZING

The Beocord 9000 has an automatic tape head demagnetizing function which differs from that of the Beocord 6000 and 8002. These models have a combination head for recording and playback, where with the aid of change-over switches the same coils are used for either receiving or emitting signals. The tape head can become magnetized in the change-over process, causing hiss in playback. This problem is solved by letting the bias current through the tape head ebb out slowly in stopping a recording, instead of cutting off the current suddenly. This slow bias ebb allows tape head remanence to return to zero on the hysteresis curve.

The same thing happens in the Beocord 9000, but only in the case of the record head. The separate tape head coils for playback are permanently connected to a pre-amplifier, and there are no change-over switches. Therefore the tape head cannot become magnetized in normal use. It can only be magnetized if subjected to an external magnetic field, e.g. by contact with a tool, in which case it must be demagnetized with, for example, a defluxer.

TIME CALIBRATION

Beocord models 9000, 8002 and 6000 display the playing-time in minutes and seconds, as opposed to the Beocenter 7002 tape counter for example, which shows a figure directly proportional to the number of revolutions made by the right-hand spool. Such a figure cannot be converted directly to playing-time; for example, 20 minutes in on a C60 cassette gives a counter reading of approx. 1725, whereas on a C90 the reading is approx. 1860.

The Beocord 9000's time calibration operates on the same basic principle as the Beocord 8000's. However, a number of features have been added, e.g. calibration from the beginning of the tape during playback, and the TAPE END function.

Real time indication requires the following references:

- Information as to the tape thickness, C60, C90 or C120 (choice of table).
- Measurement of time from the beginning of the tape.

Both conditions are satisfied in true time calibration.

Relative time calibration uses the tape thickness reference only.

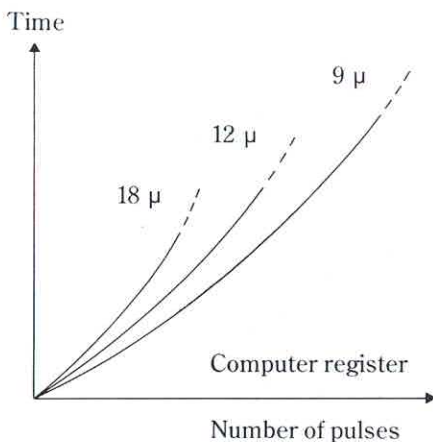

Tape thickness

The most important part of the system is the micro-computer. The micro-computer carries out all calculations and controls the minute and second readings on the display.

The computer program contains 3 tables, one for each tape thickness:

18 μm , C60 cassettes

12 μm , C90

9 μm , C120

μm stands for micrometer, 1/1000 mm.

The three tables are compiled on the basis of practical experience; large numbers of all cassettes currently on the market have been carefully measured at our laboratory in order to ensure as accurate a time indication as possible.

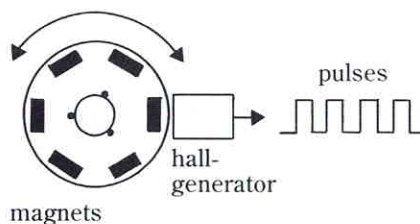

Tape thickness is measured by counting the revolutions of the right-hand spool-hub. A magnetic sensor sends electric pulses to the micro-computer. 2 revs corresponds to 12 pulses; this interval is measured and stored as reference. The tape is then wound on about 50 revs, in order to increase the radius of the spool-hub. The time taken for 2 revolutions is measured again and compared with the reference. Tape speed is constant, being determined by the capstan shaft, so that the thicker the tape, the greater the difference between the two measurements. Thus the micro-computer can tell whether the tape belong in the C60, C90 or C120 category.

Relative time calibration

Tape thickness is measured automatically on insertion of the cassette for recording or playback. After running for 1½ – 3 minutes, depending on whereabouts on tape the measuring takes place, all the digits light up, indicating that the tape has been classified as C60, C90 or C120.

However, 00.00 refers to the tape position to which the cassette was wound on insertion, so that rewinding past this point causes the display to count backwards, preceded by a minus sign (i.e. counting in negative figures). Although the tape is rewinded to 00.00 at the insertion a relative time calibration will not be exact and e.g. it cannot be used in connection with search on tape.

Calibrated						
00.00	05.00	10.00	15.00	20.00	25.00	30.00
00.00	05.17	10.30	15.41	20.51	26.00	31.09
Relative						

Here you have an example of the difference between relative and calibrated time calibration for a C60 tape. Measured in % the indication error is biggest at the beginning of the tape.

True time calibration

In addition, in order to indicate true tapetime the micro-computer has to know where the beginning of the tape is when the measuring of the tape thickness is started and use this as the reference for 00.00. This requires rewinding the tape, and this is what happens automatically with the GO function.

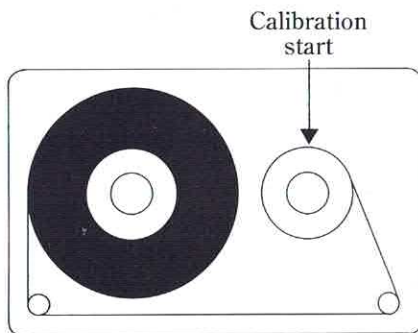

GO

Inserting the cassette and pressing GO fully rewinds the tape. The tape then automatically winds forward approximately 7 revolutions to get past the leadertape, and tape thickness is measured as described above. Finally the cassette is automatically wound back to the original tape position.

0 and GO

The waiting time involved in Beocord 6000/8000/8002 time calibration has been eliminated with the 9000: Pressing 0 and GO starts playback immediately after the automatic rewinding of the tape. Tape thickness is measured at the same time as the tape is played back normally. Calibration is completed after approx. 1½ minutes and TIME CAL then lights continuously.

TAPE END

The Beocord 9000 can also tell us how much tapetime is left during recording. When calibrated to TAPE END, the display shows how much tape-time has elapsed from the beginning, alternating with a countdown of the tape-time remaining.

This reading is based on 2 pieces of information:

- The tape thickness.
- The tape end time.

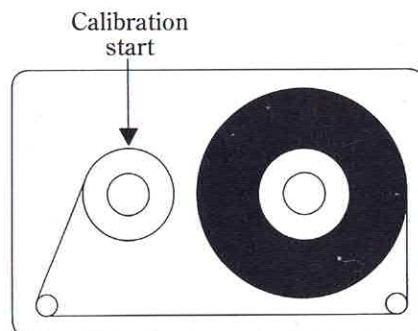

We may already know the thickness of the tape from a previous calibration from the beginning of the tape using GO, or from a relative calibration from a random point on the tape. In which case all we need to do is to wind to the end of the tape, either with the TAPE END button or by normal forward tape winding.

If the tape thickness is not already known, it is measured automatically when TAPE END is pressed, in the course of automatically winding to the end of the tape and back again to the original tape position. TAPE END can only be activated when REC OPEN is activated.

TAPE END indicator

The words »TAPE END« flash while calibration is in progress and light continuously when calibration is completed.

This indicator will also flash during recording even if no TAPE END calibration has been carried out: this happens when the rotation of the left-hand spool-hub exceeds a certain speed, corresponding to approximately 5 minutes of playing-time remaining.

What can put these times out?

As described above, the times given use the beginning of the tape as reference.

The tightness of the tape on the spools is not identical for fast winding and normal tape motion. With some makes of tape there can be up to 20 seconds difference in times given for C90 cassettes when wound differently. This gives an 0.74% indication error, or 0.95 m. tape out of a total length of 128,52 metres.

With other makes of tape, differences can be down to a few seconds.

Differences between the cassettes themselves can produce different times.

The diameter of the hub of each spool is standardized at 22 mm. If a cassette has larger spool-hubs, the indicator will in the GO function register times which are too short. As mentioned previously, we have measured tape thickness for a large number of cassettes of all relevant makes. Averages for these measurements are used as references for the Beocord 9000. However, there are makes of tape of abnormal thickness.

If for example 9 μm tape is used in a C90 cassette, it is classified as a C120 tape.

The worst that can happen is if the tape thickness is half-way between 12 μm and 9 μm , so that the tape recorder cannot decide which calculation table to use and as a result does not choose the same one the whole time. In such cases there can be several minutes' indicating error by the end of a 45 minute tape (C90).

Reduction in winding speed

The Beocord 9000 uses the same winding speed as Beocords 6000, 8000 and 8002, 70 seconds with C60 tape.

To help prolong the life of tapes, the Beocord 9000 features a low speed function which automatically reduces the winding speed just before the tape runs out.

The system operates by measuring the speed of rotation of whichever spool-hub the tape is running off. When this exceeds a certain level, the speed of the capstan motor is reduced to roughly 2/3 normal speed.

This level has been fixed so that the low speed function only cuts in when absolutely necessary. Consequently, if the tape is shorter than a C60, with the diameter of the spool-hub less than 48 mm when full, or if a cassette's spool rotates too slowly, there will be no reduction in winding speed.

CAPSTAN SYSTEM

The Beocord 9000 is designed with a single capstan.

If we look at the cassette recorder market we find both single and double capstan systems.

The buying public generally assumes that a double capstan must be better than a single capstan.

This is not necessarily the case. It depends in how the entire mechanism is dimensioned. Again it is a case of not just the choice of system but also the degree of optimization.

What counts in this case is getting low wow and flutter values, and keeping the tape in constant contact with the tape head to prevent dropouts.

Wow is the term for sound pitch variations of less than 10 Hz, caused by variations in tape speed. The result is a vibrating, wailing sound, particularly noticeable in the case of, for instance, piano notes.

Flutter is the term for variations greater than 10 Hz. Notes acquire a harsh quality as a result of being modulated with the flutter frequency.

Wow and flutter are expressed by a common % value or as a curve showing incidence at different frequencies.

Wow is usually the result of mechanical irregularities, e.g. in the capstan shaft or flywheel. In principle a single capstan is better than a double capstan system, because there are fewer moving parts.

Flutter depends more on the number of contact surfaces the tape has to pass. The tape base has a certain degree of elasticity. When the tape passes across the various contact surfaces, such as the tape head and felt pad and surfaces in

the cassette itself, there is a certain amount of friction so that the tape stretches slightly.

When the friction is overcome, the tape moves on. Tape motion continues in this way in very small jerks, sticking, stretching and starting again. In principle the double capstan system provides the most constant tape tension and hence the lowest flutter value.

Single capstan	Double capstan
Low wow %	Higher wow %
Higher flutter %	Low flutter %
Greater reliability, fewer moving parts. Requires totally optimized tape transport system.	More parts giving greater room for error. Can improve tape transport on a non-optimized transport mechanism.

The above table indicates the basic advantages and disadvantages of single and double capstan systems in a very simplified way.

It shows that if a single capstan is chosen, a technique for keeping the tape under constant tension has to be developed in order to reduce flutter.

This is exactly what we have done in the Beocord 9000, as well as in the Beocord 8000, 8002 and 6000.

Every single mechanical function has been thoroughly analyzed and measured, every component and specification optimized. This includes for instance the rotation speed of individual moving parts; the friction values of the spool hubs with no tape and all the tape on each hub; and the dimensioning for the rubber belts.

The result is very low flutter values, measured at frequencies right up to 1000 Hz and even higher.

Consequently the Beocord 9000 combines the best qualities of the single and double capstan systems.

MOTOR SYSTEM

The Beocord 9000 has a single motor.

Again, many people think that the more motors the better.

As far as the wow and flutter specifications are concerned, one motor gives just as good results as several motors.

Increasing the number of motors may make things easier for the designer, without making the sound reproduction any better than it is with one motor.

Reliability and life span are also affected by the number of motors.

The Beocord 9000 has a tacho-controlled DC motor, connected to the capstan axle by a flat rubber belt of carefully specified elasticity. The two spool hubs are connected to the motor via separate belts, which have no connection with the capstan axle.

The motor has a double shield to reduce mechanical noise and flexible suspension to prevent vibrations from being transmitted to the tape transport system.

Effective measures have also been taken to minimize the emission of electric noise from the motor. Every single motor in a multi-motor system transmits its radiated field to the electronics around about it, which is one more reason for limiting the system to a single motor.

The result of optimizing all these details in the mechanics of the Beocord 9000 is a tape transport system which is the equal of a 3 motor system, both with respect to specifications and reliability.

The entire mechanical system has been developed by Bang & Olufsen right down to the last detail. It is produced to strict specifications by a firm under contract to B&O. It is supplied exclusively to B&O, and therefore is not to be found in any other make of cassette recorder.

WHAT HAPPENS IF THE POWER IS CUT OFF?

The Beocord 9000's micro-computer has a Random Access Memory (RAM), which, among other things, stores all information and programs read in and out of the micro-computer and other electronic systems in the course of normal operation.

If the power to the Beocord 9000 were cut off, the RAM would lose all this information. Therefore a lithium battery has been built in to ensure the retention of all essential data.

The lithium battery does not power the micro-computer itself, which has a relatively high power consumption. An extra memory IC is used instead, a component containing a RAM with low power consumption. Lithium batteries are characterized by their long lifetimes, due to a low self-discharging current. The life of this particular battery is estimated at more than 5 years.

Replacement, which involves soldering, is carried out as part of servicing.

The battery cuts out automatically when the tape recorder is powered by the mains.

The memory IC and lithium battery ensure that the following functions are retained:

- REC OPEN
- REC CAL
- TIME CAL.

This means that the recording calibration for each tape type is retained. Only if the cassette is removed while the power is off, will REC OPEN, the REC CAL for that specific tape, and TIME CAL be cancelled, just as in normal operation.

The following is also retained:

- TIMER START and
- TIMER STOP programming.

On the other hand, the clock will stop at the time of the power cut, as it is powered by the mains frequency, 50 or 60 Hz, which is out of the question for a DC battery. The clock has to be reset with TIME SET.

MODIFICATION OF TECHNICAL DATA

In comparing Beocord 8002 and Beocord 9000 specifications most people will notice a change in the values for:

- Signal-to-noise ratio Dolby NR
- Radio input sensitivity

Signal-to-noise ratio		Beocord 8002	Beocord 9000
		Measured DIN A curve	Measured CCIR/ARM curve
Dolby NR	metal	>68 dB	B: >68 dB, C: >79 dB
	chrom	>66 dB	B: >70 dB, C: >80 dB
	ferro	>64 dB	B: >64 dB, C: >74 dB

With the Beocord 9000 we have gone over to using a CCIR/ARM curve is measuring the signal-to-noise ratio for Dolby B and Dolby C noise reduction. The reason being that it is a more appropriate measure than the DIN A curve when dealing with the perception of tape hiss by the human ear. Furthermore, Dolby laboratories use this method of measurement.

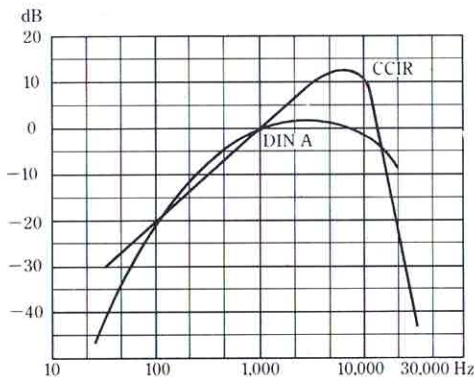

Both curves are shown here for comparison. CCIR/ARM stands for Comité Consultatif International des Radiocommunication/Average Reading Meter. Measurement using DIN A and CCIR cannot be compared directly. In some cases DIN A gives the higher value, in others CCIR, depending on the noise spectrum of the given tape. If there is a relatively high noise level, e.g. between 1,000 and 15,000 Hz, we get a lower and therefore inferior value measuring with CCIR rather than with DIN A, a difference of about 10 dB at 17,000 Hz. This difference is only significant in a purely technical sense; it does not represent the actual aural impression.

With Dolby C we are virtually at the limit for the perception of tape hiss by the human ear. Consequently, using the CCIR curve can be regarded as an equivalent updating of our measuring technique, so that we get the most accurate expression of the real aural experience.

Radio input DIN-LINE sensitivity

	Beocord 8002	Beocord 9000
Radio input DIN	1 mV/10 kohms	0,4 mV/4,7 kohms
Radio input LINE	40 mV/470 kohms	15 mV/22 kohms

Lower figures for the 9000 do not reflect a need for increased sensitivity; they represent a better signal-to-noise ratio in input amplifiers.

Dolby C noise reduction gives an improvement of about 10 dB compared to Dolby B. In order not to lose this improvement elsewhere in the tape recorder, inherent noise in the input stages had to be reduced. The process of optimizing negative feedback and input impedance has been carried even further, so that the noise contributed is less than the tape hiss. The result of these improvements is lower mV figures for sensitivity and lower kohm figures for load resistance, which does not mean that the values for the corresponding signals to and from the radio receiver have been altered. In the DIN function the signal is still transmitted as a signal current, and as the mV and kohm value have both been reduced, the signal current remains the same as in the Beocord 8002.

Something similar takes place in the LINE function:

The lower load impedance of 22 kohms is counterbalanced by the corresponding increase in sensitivity, so that the effective signal current remains the same.

In both DIN and LINE functions a relatively long cable can be used without adverse affect on treble characteristics.

TECHNICAL DATA

Beocord 9000	Type No. 4814
Compact cassette	C46-C60-C90-C120
Tape head	Double, sendust/ferrite
Noise reduction system	Dolby NR-B and NR-C
Tape switch	Aut. ferro/ferrochrom/chrom/metal
Wow and flutter DIN	<±0.1%
Wow and flutter WRMS	<0.045%
Speed deviation	<±1%
Fast forward and rewind C60	70 sec.
Frequency range ref. 250 nWb/m-20 dB	10-25,000 Hz ±3 dB
Fe, FeCr, Cr, metal	20-20,000 Hz ±1.5 dB
S/N ratio Dolby NR CCIR/ARM weighted	
Metal Scotch Metafine C90	B: >68 dB, C: >79 dB
Ferrochrom Sony FeCr C90	B: >68 dB, C: >79 dB
Chrom BASF chrom II C90	B: >70 dB, C: >80 dB
Ferro BASF LH I C60	B: >64 dB, C: >74 dB
S/N ratio Dolby OFF DIN weighted	
Metal Scotch Metafine C90	>59 dB
Ferrochrom Sony FeCr C90	>59 dB
Chrom BASF chrom II C90	>60 dB
Ferro BASF LH I C60	>56 dB
Driveability metal ref. 250 nWb/m	10 kHz >-3 dB, 15 kHz >-6 dB
Driveability FeCr, Cr, Fe 250 nWb/m	10 kHz >-10 dB
Channel separation 1 kHz	>40 dB
Erase 1 kHz	>75 dB
Erase frequency	96 kHz
Radio input DIN-LINE	0.4 mV/4.7 kohms - 15 mV/22 kohms
Microphone input	0.15 mV/3 kohms
AUX input	40 mV/22 kohms
Radio output adjustable	1000 mV (500-2000 mV) 5.6 kohms
Headphones	Max. 10 V/56 ohms
Power supply	220 volts
Power frequency	50-60 Hz
Power consumption	Max. 50 watts
Dimensions W x H x D	53 x 13 x 30 cm
Weight	7.8 kg

Bang & Olufsen

Bang & Olufsen of America, Inc. 515 Busse Road, Elk Grove Village, Illinois 60007