

---

**RCSL No:** 44-RT1980  
**Edition:** February 1981  
**Author:** Mogens V. Pedersen

---

**Title:**

RC721 and RC722 Keyboards  
Technical Manual

---

---

**Keywords:**

RC700, RC702, RC721, RC722, KTC401, KTC402, KTC403.

---

**Abstract:**

This manual contains a technical description of the two keyboards RC721 and RC722.

(26 printed pages)

---

**Copyright © 1981, A/S Regnecentralen af 1979  
RC Computer A/S**

**Printed by A/S Regnecentralen af 1979, Copenhagen**

**Users of this manual are cautioned that the specifications contained herein are subject to change by RC at any time without prior notice. RC is not responsible for typographical or arithmetic errors which may appear in this manual and shall not be responsible for any damages caused by reliance on any of the materials presented.**

FOREWORD

This paper describes the two keyboards RC721 and RC722. The first is without a numeric block, and the later is with this block. Both keyboards contain the same microcomputer and the same program. The other circuits in the boards are almost identical.

This paper is divided in the following parts:

Keyboards RC721 and RC722

Circuit diagrams

Cable CBL923

Alphabet

National variants.



<u>TABLE OF CONTENTS</u>	<u>PAGE</u>
1. KEYBOARDS RC721 AND RC722 .....	1
2. CABLE CBL923 .....	7
3. ALPHABET .....	9
4. NATIONAL VERSIONS .....	11



1. KEYBOARDS RC721 and RC722

1.

The technical name for RC721 is KTC401, and for RC722 it is KTC403. The block diagram in fig. 1 shows how the logic is made. The circuit is controlled by a CPU from the Intel family 8048. The block diagram for this CPU is shown in fig. 2. A more detailed description of the CPU may be obtained from an Intel manual.

When a key is pressed the capacity between the X wire and the Y wire increases. The CPU sends an address to the X transmitter, which sends a pulse on the wire addressed. When a key is pressed the pulse is received on the Y wire and information about the position of the pressed key is received by the CPU. The program takes care of any jitter which may accure, and also of the N-KEY roll-over function. The ASCII value of the key pressed is generated by the CPU and sent to the OUT REG together with a strobe signal.

The IN REG and the EXTERN ASCII ROM are not used in KTC401 and KTC403.

MVP 810202

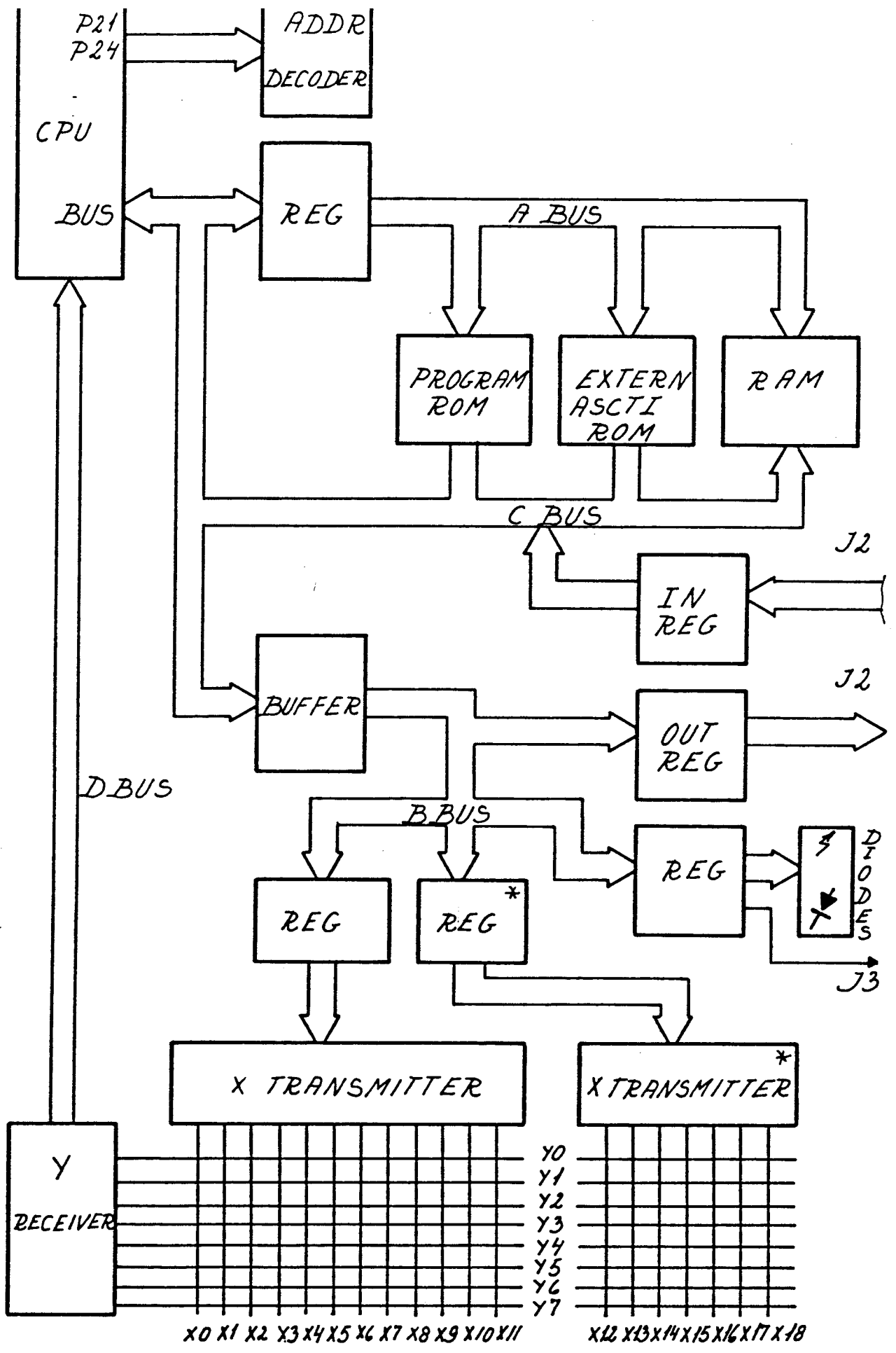

Fig. 1 BLOCK DIAGRAM KTC 401/KTC 403.

R 21330

\* Only in KTC 403



MCS - 48 MICROPROCESSORS

I 8048	8 - BIT	microcomputer	with	ROM.
I 8748	- -	-	-	EPROM
I 8035	- -	-	-	ext. MEMO.

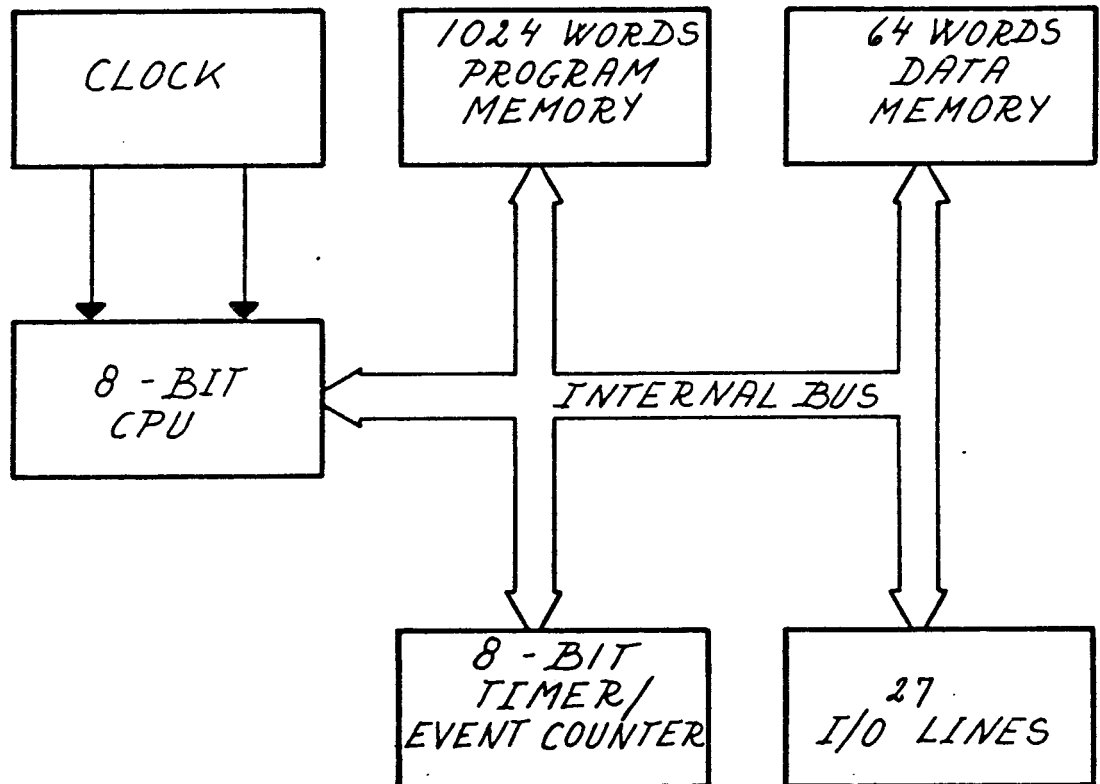

MVP 810202

Fig. 2. BLOCK DIAGRAM for CPU-8048.



18 POL. IC-FASSUNG (VERBUNDIG ZUR TASTATURENWEITERUNG)

ASCII VERSION  
SERIELL VERSTÄ  
ASCII-TABELLE

C9	1
C10	2
C11	3
C12	4
C13	5
C14	6
C15	7
C16	8

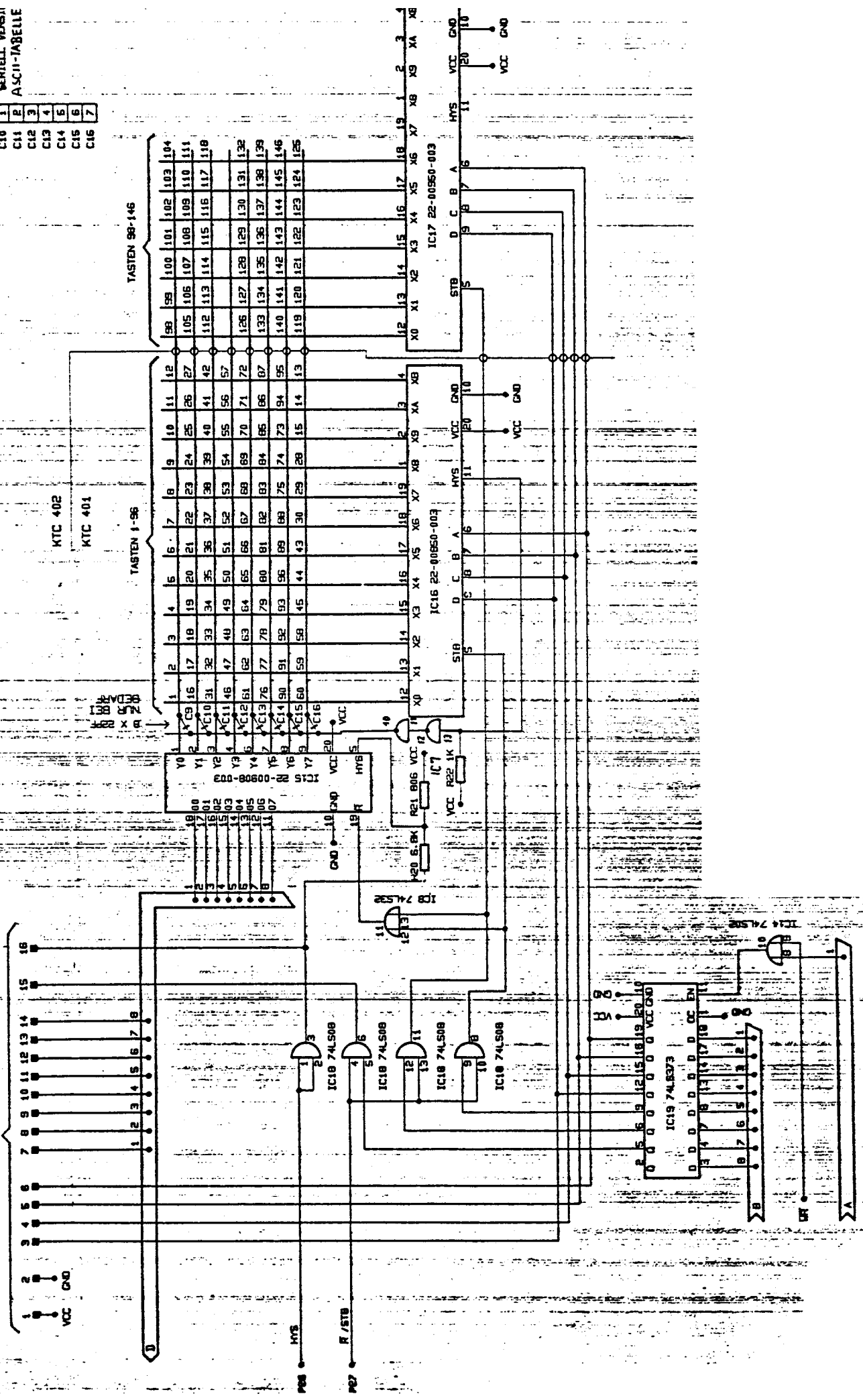

KTC 402  
KTC 401

TASTEN 98-146

TASTEN 1-96

STECKER 2 (PARALLEL)

STECKER 3

LEIS WERDEN  
VOM KUNDEN BESTUECKT

- L1, L9, L16, L24, L31, L39, L59, L106, L113
- L2, L10, L17, L25, L32, L40, L100, L107, L114
- L3, L11, L18, L26, L33, L41, L101, L108, L115
- L4, L12, L19, L27, L34, L42, L102, L109, L116
- L5, L13, L20, L28, L35, L43, L103, L110, L117
- L6, L14, L21, L29, L36, L44, L104, L111, L118
- L7, L15, L22, L30, L37, L45
- L8, L18, L23, L105, L38, L112

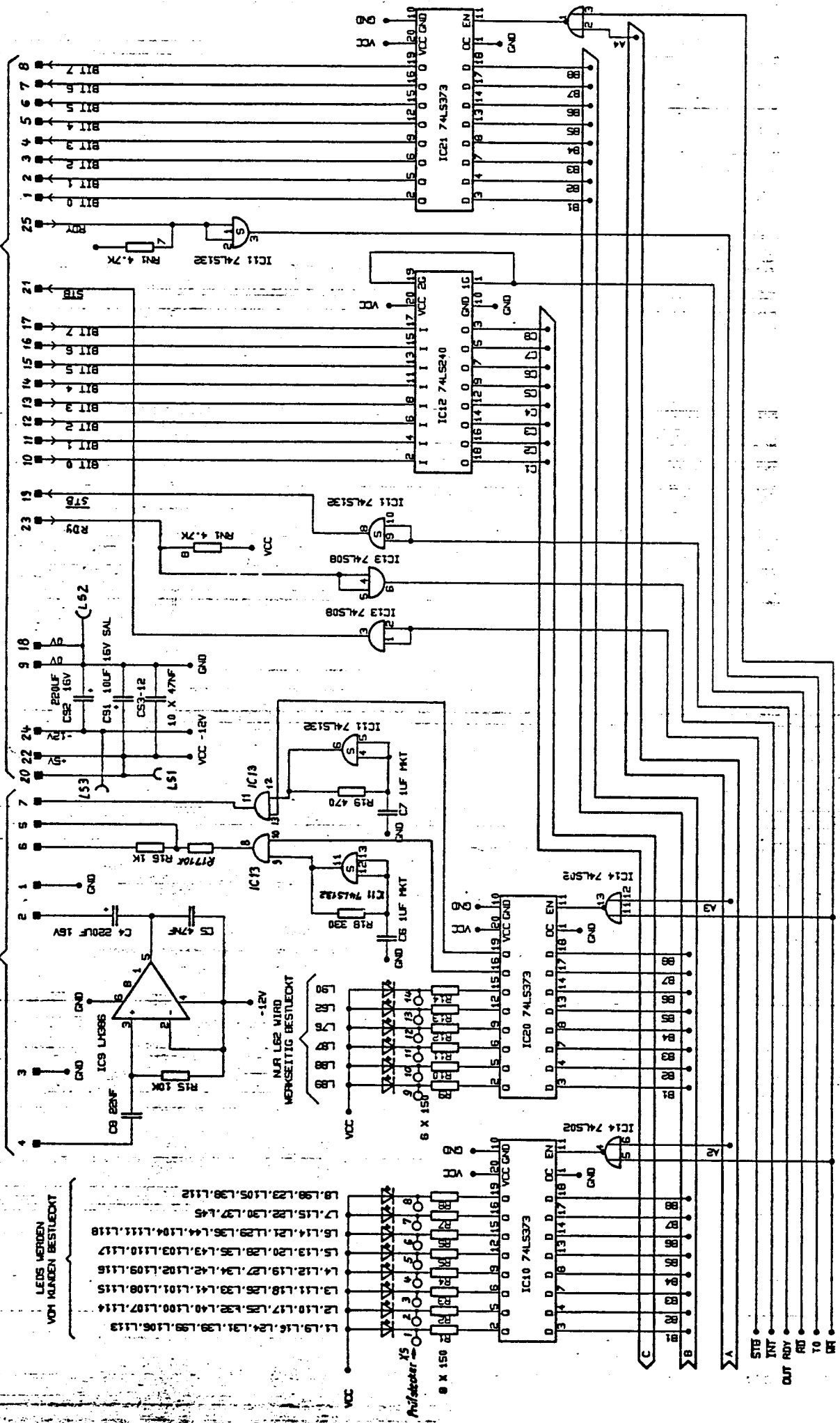

Profitecster X5  
8 x 150

M.R. L22 WIRD  
MENSUELLIG BESTUECKT

STB  
INT  
OUT  
RDY  
TO  
BR

2. CABLE CBL923

2.

Fig. 3 shows the cable CBL923 which connects the keyboard to the computer, normally RC702. Power to the keyboard is supplied from the computer using CBL923.

CONNECTOR 1 TO KEYBOARD		CONNECTOR 2 TO COMPUTER	
PIN NO.	SIGN. NAME KEYBOARD	SIGN. NAME RC 702	PIN No.
1	OUT 0	KEY 0	22
2	OUT 1	KEY 1	23
3	OUT 2	KEY 2	24
4	OUT 3	KEY 3	21
5	OUT 4	KEY 4	17
6	OUT 5	KEY 5	18
7	OUT 6	KEY 6	19
8	OUT 7	KEY 7	20
21	$\overline{STB}$	KEY STROBE	12
9	0V	0V	13
18	0V	0V	3
22	+5V	+5V	25

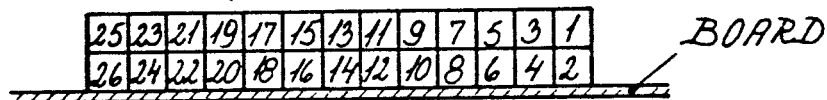

25 POL CANNE  
CONNECTOR

PIN LAY OUT FOR CONNECTION  
TO KEYBOARD.

Fig. 3. CABLE TO KEYBOARD CBL 923.

R 21332

MVF 870602

3. ALPHABET

3.

Fig. 4 shows the ASCII Alphabet supplied from the keyboard. Notice that 8 bits are used so it is an 'extended' ASCII alphabet which the keyboard supplies.

RC 721

RC 722

00	95	96	97	99	9C	9D	9E	9F	C0	E0	FD	FE	DD	DE	E5	E7	F4	E2	E3	F3	F8
80	81	82	83	84	86	87	88	8E	8F	90	91	92	93	94	C5	C7	D4	C2	C3	D3	D8
FF	8C	12	13	14	15	16	17	19	1C	1D	1E	1F	9A	8A	E8	E9	EF	EB	EC	E1	F2
7F	0C	01	02	03	04	06	07	08	0E	0F	10	11	1A	0A	C8	C9	CF	CB	CC	C1	D2
85	21	22	23	24	25	26	27	28	29	30	3D	3E	88	98	E9	EA	AA	F6	F0	E6	AF
05	31	32	33	34	35	36	37	38	39	3A	3B	3C	08	18	CA	CC	8A	D6	D0	C6	BF
9B	09	51	57	45	52	54	59	55	49	4F	50	5D	2B	8D	ED	EE	85	A7	A8	A9	8D
1B	09	71	77	65	72	74	79	75	69	6F	70	7D	38	0D	CD	CE	05	B7	B8	B9	0D
CTRL	ALPHA	41	53	44	46	47	48	4A	4B	4C	5B	5C	2A	8A	F1	F5	8D	A4	A5	A6	88
LOCK	LOCK	61	73	64	66	67	68	6A	6B	6C	78	7C	3A	0A	D1	D5	AD	B4	B5	B6	08
SHIFT	60	5A	58	43	56	42	4E	4D	3C	3E	3F	SHIFT	FC	FC	F7	98	F9	A1	A2	A3	BC
SHIFT	40	7A	78	63	76	62	6E	6D	2C	2E	2F	DC	DC	DC	D7	18	D9	B1	B2	B3	AC
SHIFT	FF	8C	0A	0A	0A	20	20	0A	0A	0A	C0	E0	FD	FD	FA	FB	89	8B	8B	8E	A0
LOCK	7F	0C	20	20	20	20	20	20	20	20	8F	90	91	91	DA	DB	09	AB	80	AE	20

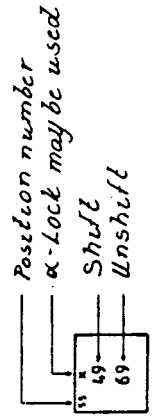

Fig. 4 DECIMAL CODE A SHIFTER AND LOCKS



4. NATIONAL VERSIONS

4.

RC721 and RC722 may be supplied in a number of national versions. This is done only by changing a number of keytops. The rest of the change is done in the software in RC702. It is the same keytops which are changed in RC721 and RC722. Lay out of the following versions is shown:

Fig. 5 shows RC721,001 keyboard Danish alphabet.

Fig. 6 shows RC721,002 keyboard Swedish alphabet.

Fig. 7 shows RC721,003 keyboard USA ASCII alphabet.

Fig. 8 shows RC721,004 keyboard German alphabet.

Fig. 9 shows RC721,005 keyboard UK ASCII alphabet.

fig. 10 shows RC722,001 keyboard Danish alphabet.

Fig. 11 shows RC722,006 keyboard Bibliotek alphabet.

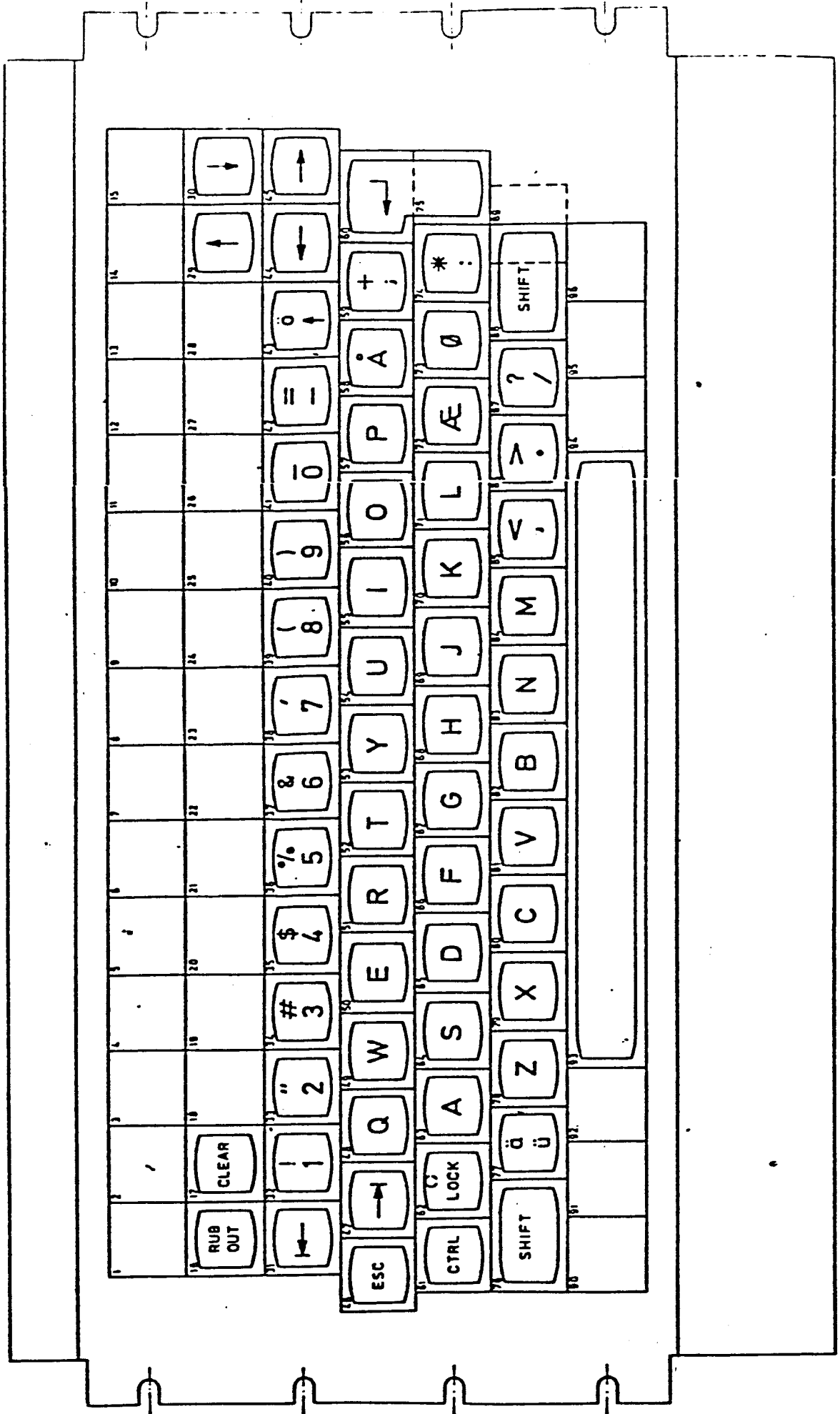

Fig. 5. LAY OUT RC 721,001 DANISH



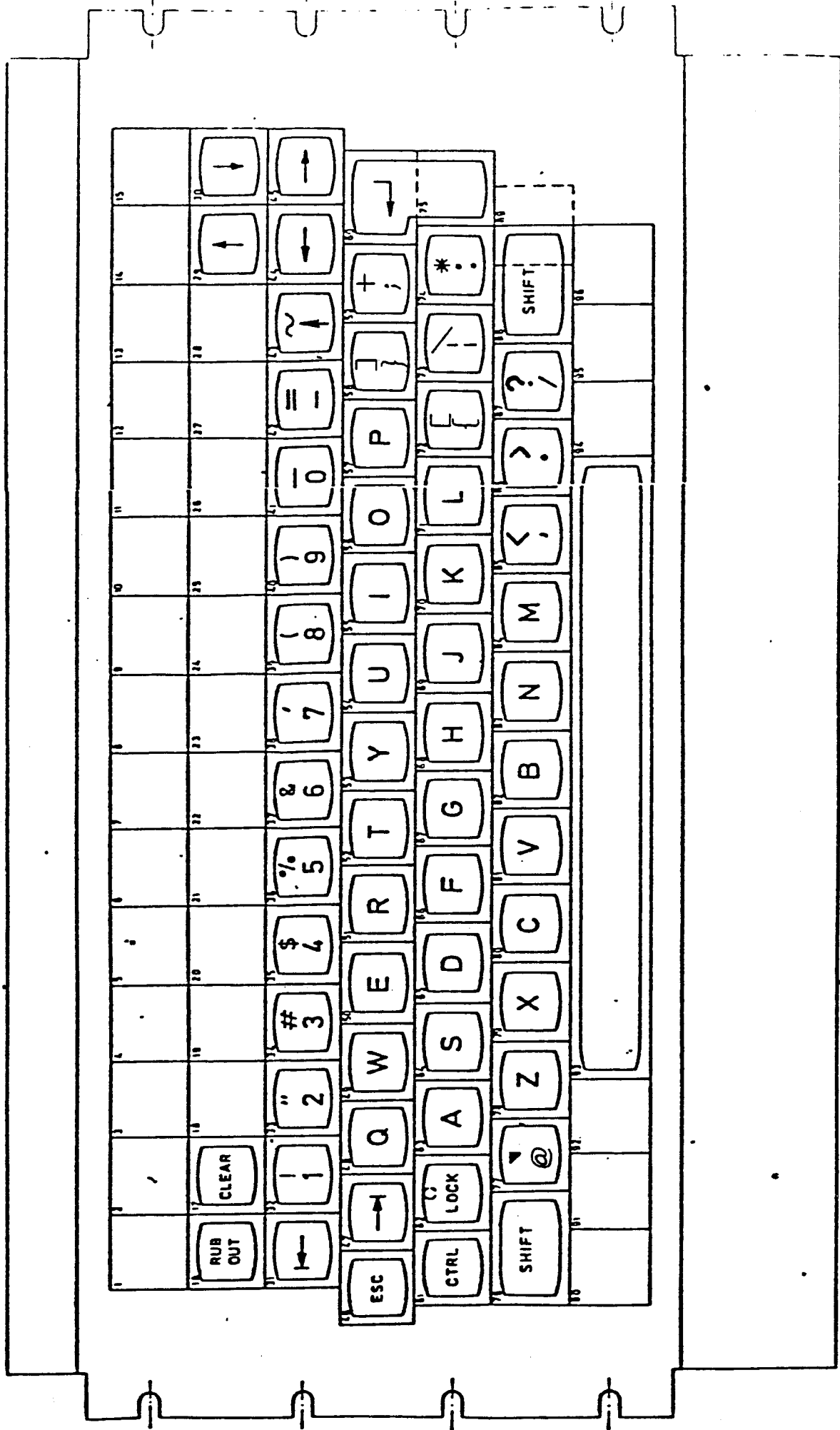

Fig. 7. LAY OUT RC 721, 003 US ASCII





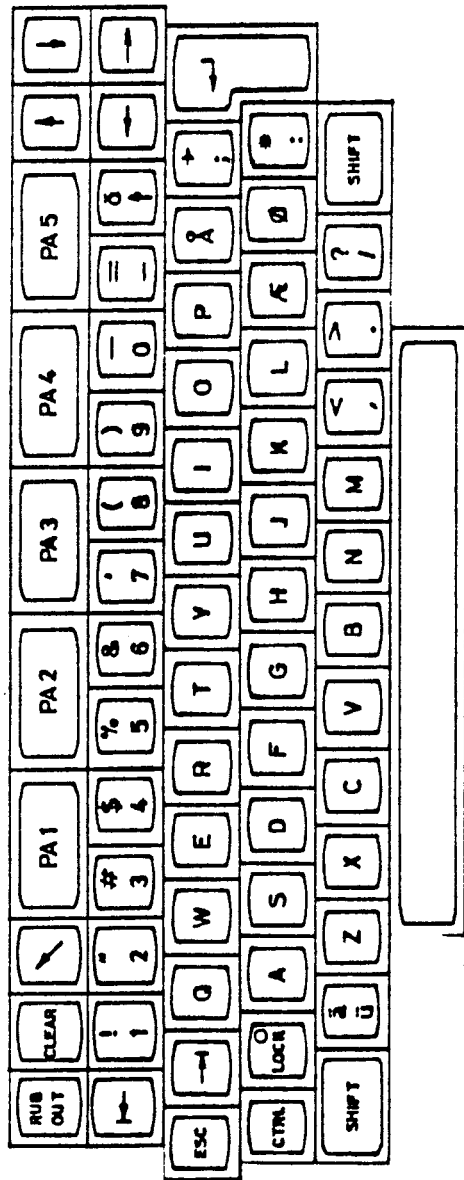

Fig 10 LAY OUT RC 722, 001 DANISH





**RETURN LETTER**

Title: RC721 and RC722 Keyboards  
Technical Manual

RCSL No.: 44-RT1980

A/S Regnecentralen af 1979/RC Computer A/S maintains a continual effort to improve the quality and usefulness of its publications. To do this effectively we need user feedback, your critical evaluation of this manual.

Please comment on this manual's completeness, accuracy, organization, usability, and readability:

---

---

---

---

Do you find errors in this manual? If so, specify by page.

---

---

---

---

How can this manual be improved?

---

---

---

---

Other comments?

---

---

---

---

---

Name: \_\_\_\_\_ Title: \_\_\_\_\_

Company: \_\_\_\_\_

Address: \_\_\_\_\_

Date: \_\_\_\_\_

Thank you

..... **Fold here** .....

..... **Do not tear - Fold here and staple** .....

**Affix  
postage  
here**

 **REGNECENTRALEN**  
af 1979

**Information Department  
Lautrupbjerg 1  
DK-2750 Ballerup  
Denmark**