

HM/NBL 800822 LLM REV. 810409 LLM



J1
ITT Cannon, type DB - 25 P

PIN	GEN. ADR.	SIGNAL NAME
1		0V
2		0V
3		0V
4		0V
5		0V
6		0V
7		0V
8		0V
9		0V
10		0V
11		+ 5V
12		+ 5V
13		+ 5V
14		- ADR 0
15		- ADR 1
16		- ADR 2
17		- ADR 3
18		- ADR 7
19		- ADR 6
20		- ADR 5
21		- ADR 4
22		- CH 256 - 511 A
23		+ 5V
24		+ 5V
25		+ 5V

800904 GR 800905 LLM REV. 810409 LLM

DBSL: 064



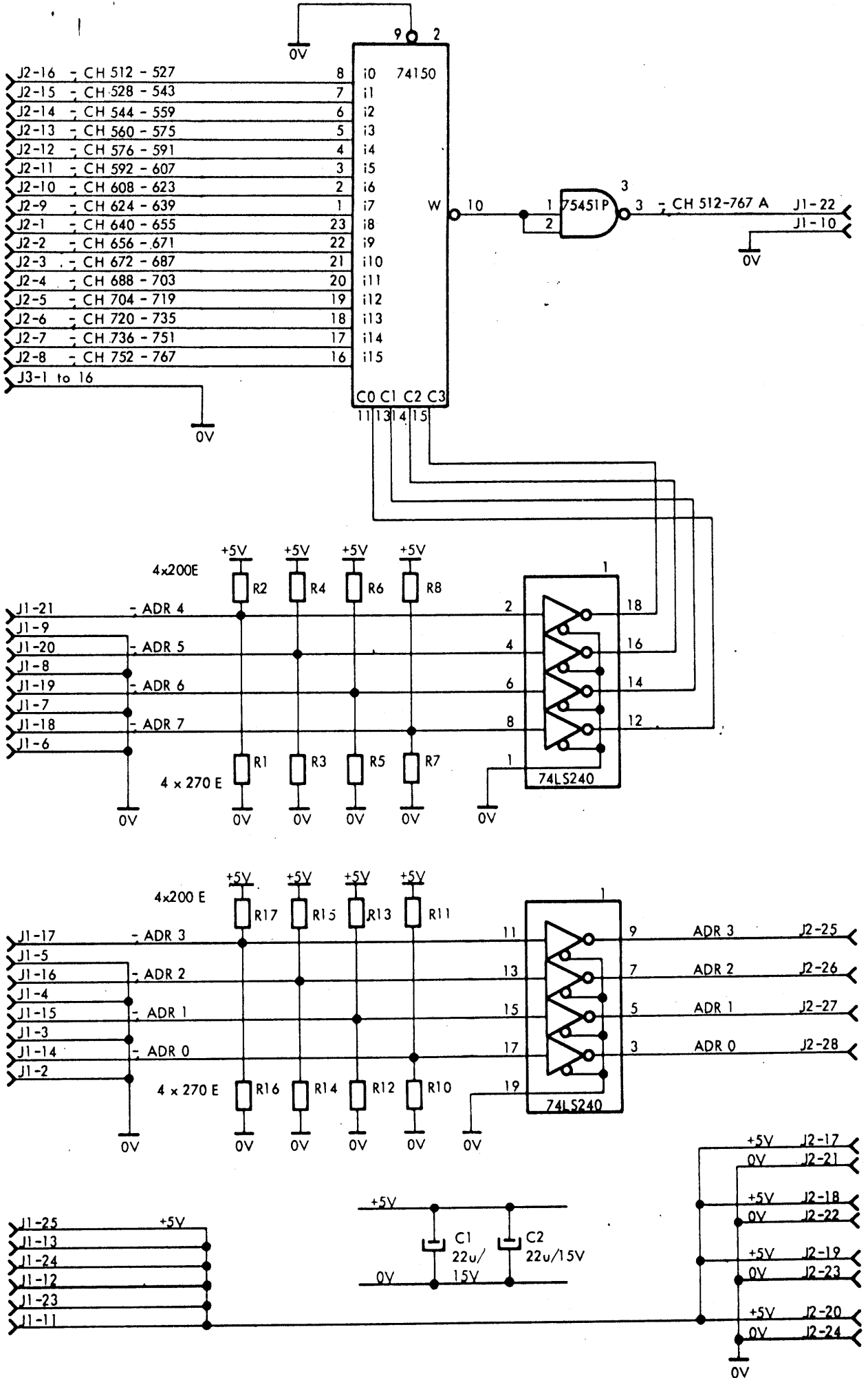

HM/NBL 800822 LLM REV. 810409 LLM



J1
ITT Cannon, type DB - 25 P

PIN	GEN. ADR.	SIGNAL NAME
1		0V
2		0V
3		0V
4		0V
5		0V
6		0V
7		0V
8		0V
9		0V
10		0V
11		+ 5V
12		+ 5V
13		+ 5V
14		- ADR 0
15		- ADR 1
16		- ADR 2
17		- ADR 3
18		- ADR 7
19		- ADR 6
20		- ADR 5
21		- ADR 4
22		- CH 512 - 767 A
23		+ 5V
24		+ 5V
25		+ 5V

DBSL: 064

800904 GR 800905 LLM REV. 810409 LLM



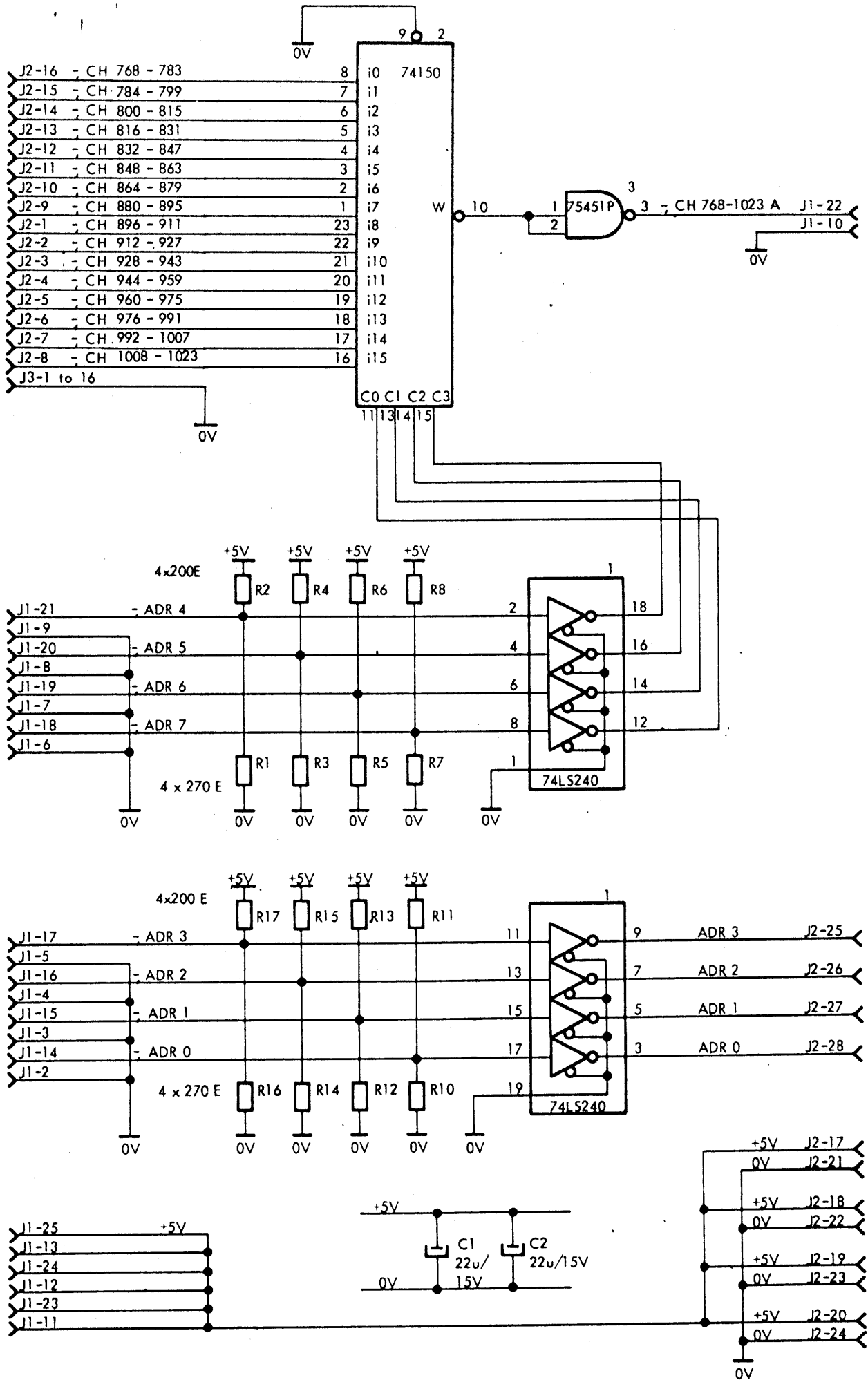

HM/NBL 800822 LLM REV. 810409 LLM



J1
ITT Cannon, type DB - 25 P

PIN	GEN. ADR.	SIGNAL NAME
1		0V
2		0V
3		0V
4		0V
5		0V
6		0V
7		0V
8		0V
9		0V
10		0V
11		+ 5V
12		+ 5V
13		+ 5V
14		- ADR 0
15		- ADR 1
16		- ADR 2
17		- ADR 3
18		- ADR 7
19		- ADR 6
20		- ADR 5
21		- ADR 4
22		- CH 768 - 1023 A
23		+ 5V
24		+ 5V
25		+ 5V

REV. 810409 LLM

800905 LLM

800904 GR

DBSL: 064



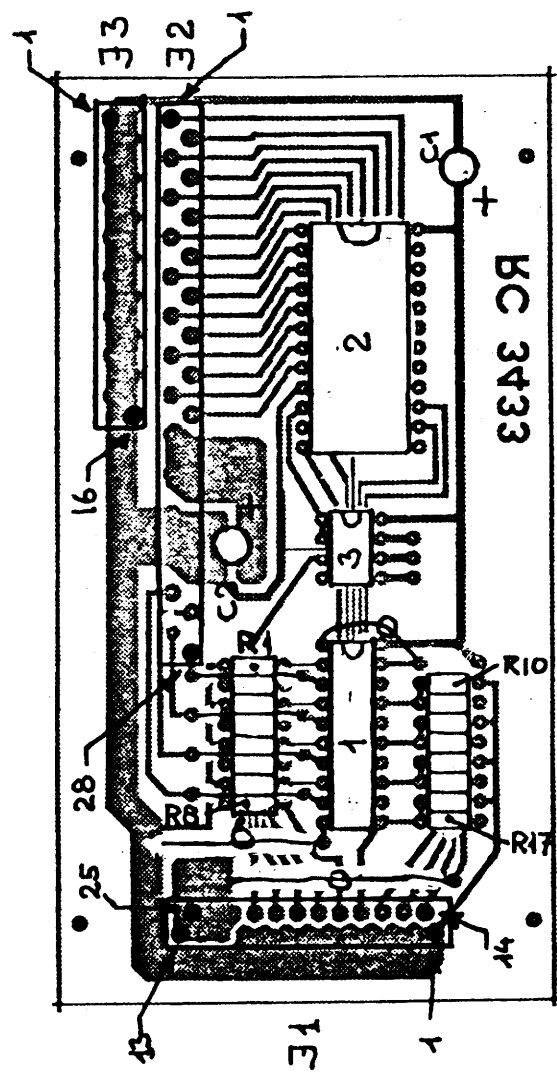

EIR 101-103
A 25922

Channel Multiplexer Board
PCB Assembly Drawing

RC 3433

