

Internal use only

RCSL No: 991 09823
Edition: April 1985
Author: Troels H. Johansen

Title:

RC750 Winchester disk
OEM Manual
WDD703

Keywords:

RC750, WDD703, Winchesterdisk, 10 MB, MiniScribe 3012.

Abstract:

This manual contains the MiniScribe 3 Product Manual

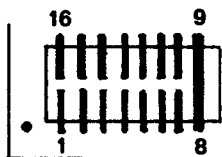

BETEGNELSE WDD 703 DISK DRIVE		UDGAVE	
		02	07
		03	08
		04	09
		05	10
		06	11
PA PART NR.	PA TEGN. PART NR.	TEGN NR.	
DESIGN hc	MONTAGE	760 53 220	
01 UDGAVE 831202			



MINISCRIBE III

PRODUCT MANUAL

(SUBJECT TO CHANGE WITHOUT NOTICE)

MiniScribe Corporation
410 South Sunset
Longmont, Colorado 80501

(303) 651-6000



TABLE OF CONTENTS

1.0	Introduction.....	1
2.0	Product Specifications.....	2
2.1	Model Specifications.....	2
2.2	Performance Specifications.....	2
2.3	Power Requirements.....	2
2.4	Physical Characteristics.....	3
2.5	Environmental Characteristics.....	3
2.6	Reliability and Maintenance.....	3
2.7	General Characteristics.....	3
3.0	Functional Description.....	5
3.1	Read/Write Control Electronics.....	5
3.2	Drive Mechanism.....	5
3.3	Air Filtration System.....	5
3.4	Head Positioning Mechanism.....	5
3.5	Read/Write Heads and Disks.....	6
3.6	Mechanically Isolated Mounting Points.....	6
3.7	Track Zero Detector.....	6
4.0	Operational Description.....	7
4.1	Power Sequencing.....	7
4.2	Drive Selection.....	8
4.3	Track Accessing.....	8
4.4	Head Selection.....	8
4.5	Read Operation.....	8
4.6	Write Operation.....	9
5.0	Electrical Interface.....	10
5.1	Control Input Signals.....	10
5.2	Control Output Signals.....	15
5.3	Data Transfer Signals.....	17
5.4	Customer Operations.....	19
5.5	Terminators.....	20
5.6	Error Messages.....	20
6.0	Physical Interface.....	21
6.1	J1/P1 Connector-Control Signals.....	21
6.2	J2/P2 Connector-Data Signals.....	21
6.3	J3/P3 Connector-DC Power.....	22
6.4	J4/P4 Connector-Frame Ground.....	22
7.0	Track Formatting Guidelines.....	23
8.0	Installation.....	24
8.1	Unpacking and Inspection.....	24
8.2	Repacking.....	28
8.3	Configuration.....	29
8.4	Mounting.....	29
8.5	Cabling.....	29

9.0	Printed Circuit Card Replacements.....	30
10.0	Diagnostic and Exerciser Routines.....	32
10.1	General Description.....	32
10.2	Message Readout.....	32
10.3	Message Definitions.....	33
10.4	Shipping Zone.....	33
	Flow Charts.....	34

LIST OF FIGURES

2-1	Outline and Mounting Dimensions.....	4
4-1	Power-on Timing.....	7
5-1	Cable Interconnection-4 Drive System.....	12
5-2	Control Signal Driver/Receiver.....	13
5-3	Seek Mode Timing.....	15
5-4	Data Signal Driver/Receiver.....	17
5-5	Read/Write Timing.....	18
5-6	Shunt Block.....	20
6-1	P1/P2 Connector.....	21
6-2	P3 Connector.....	22
8-1	Unpacking/Packing Single Pack	25
8-2	Unpacking/Packing 6 Pack Multipack.....	27
9-1	Board Replacement.....	31

LIST OF TABLES

5-1	P1/P2/P3 Connector Pin Assignment.....	11
5-2	Write Pre-Compensation Rules.....	18
5-3	Drive Selection Configurator.....	19

1.0 INTRODUCTION

The MiniScribe III is a half-height random access 5-1/4 inch rigid media disk drive employing Winchester technology. Both models utilize rack-and-pinion actuators, microprocessor control, and open loop stepper head positioning.

Both models feature power up diagnostics, head shipping zone, buffered seek and 5Mbit/Sec transfer rate. D.C. voltages and physical form factor are the same as the 5-1/4 inch half height floppy.

2.0 PRODUCT SPECIFICATIONS

2.1 MODEL SPECIFICATIONS

Storage Capacity

Unformatted	Model 3006	Model 3012
Per Drive	6,374,592 Bytes	12,749,184 Bytes
Per Surface	3,187,296 Bytes	6,374,592 Bytes
Per Track	10,416 Bytes	10,416 Bytes
Per Cylinder	20,832 Bytes	20,832 Bytes

Disk	1	1
Recording Heads	2	2
Cylinders	306	612
Data Tracks	612	1224

Recording Density

Areal	4.87×10^6 bits/sq.in.	5.9×10^6 bits/sq.in.
Linear (MFM)	8290 bpi	10,000 bpi
Radial	588 tpi	588 tpi

2.2 PERFORMANCE SPECIFICATIONS

Rotational Rate	3600 RPM \pm 1%	3600 RPM \pm 1%
Data Transfer Rate	5.0 Mbits per second	5.0 Mbits per second
Access Time		
Average Latency	8.33 ms	8.33 ms
Settling Time	15 ms	15 ms
Seek Time		
Track to Track	3 ms	3 ms
Average*	85 ms	155 ms
Maximum*	205 ms	420 ms

* Buffered including settling time

2.3 POWER REQUIREMENTS

DC Input +12 Volts DC
Steady State: \pm 5%, 1.1 amps maximum. Maximum Ripple allowed is 1% with equivalent resistive load.
Start Surge: \pm 10%, 2.5 amps maximum. (12 Seconds Typical.)

+ 5 Volts DC
 \pm 5%, 1.5 amps
Maximum Ripple allowed is 2% with equivalent resistive load.

AC Input None required

2.4 PHYSICAL CHARACTERISTICS

Outline Dimensions	See Figure 2-1
Mounting Dimensions	See Figure 2-1
Weight	3.5 pounds
Heat Dissipation (typical)	17 Watts

2.5 ENVIRONMENTAL CHARACTERISTICS

Temperature	
Operative (stabilized)	40° F (4° C) to 115° F (46° C)
Non-operative	-40° F (-40° C) to 135° F (57° C)

Humidity	
Operative and Non-Operative	8% to 80% non-condensing
Maximum Wet Bulb	78 F (26° C)

2.6 RELIABILITY AND MAINTENANCE

MTBF	8,000 hours (continuous operation)
MTRR	30 minutes
Preventive Maintenance	None
Component Design Life	5 years
Data Reliability	1 recoverable error in 10^{10} bits read 1 permanent error in 10^{12} bits read (not recoverable in 16 reads) 1 seek error in 10^6 seeks

Media Defect Criteria (as shipped from MiniScribe)

Model 3006 and 3012	20 defects maximum <2 bytes in length Cylinder zero defect free
---------------------	---

2.7 GENERAL CHARACTERISTICS

Start Time (Typical)	20 seconds from power application to - Ready
Stop time (typical)	15 seconds from power removal

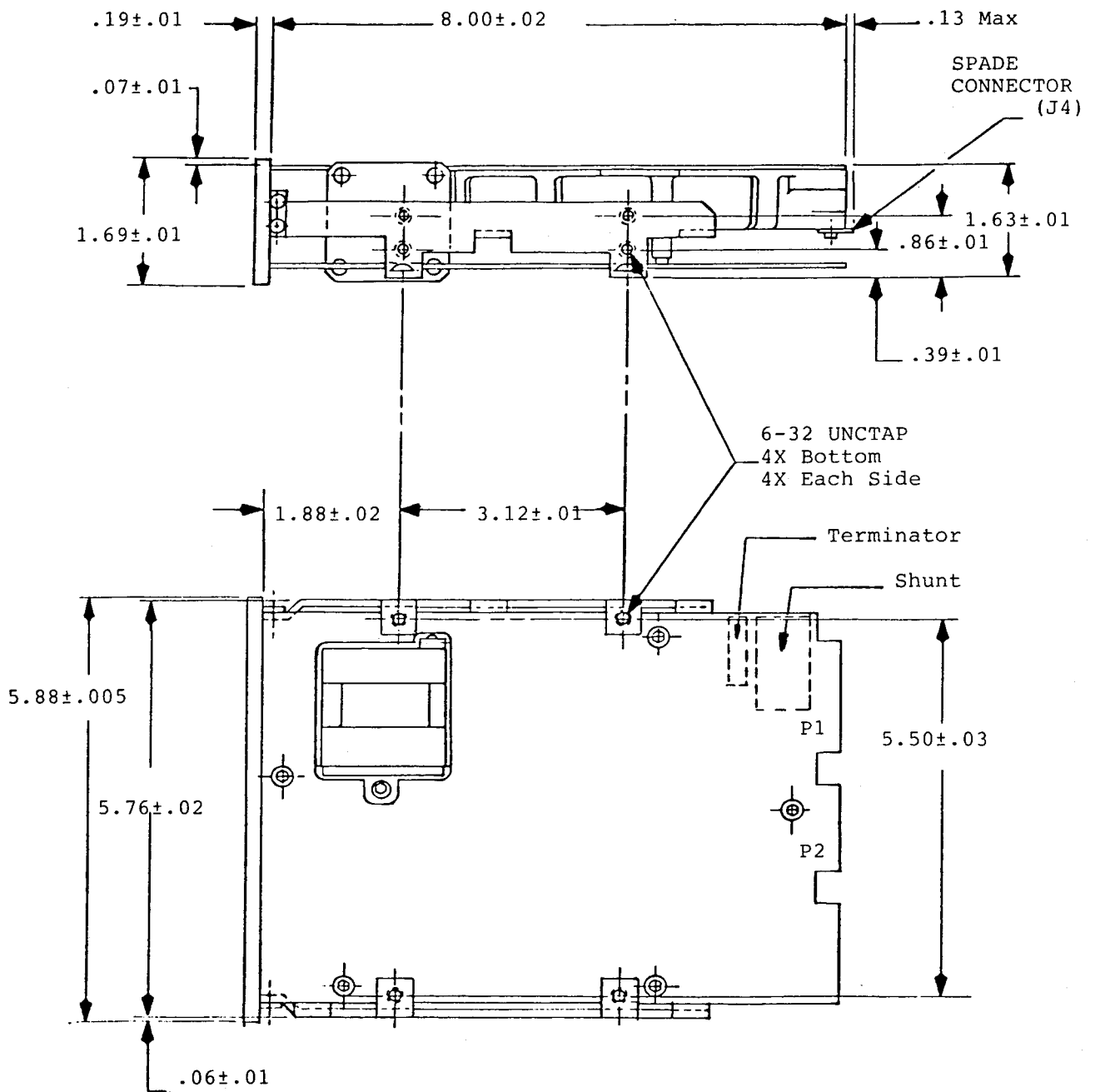

Figure 2-1
OUTLINE OF MOUNTING DIMENSIONS

3.0 FUNCTIONAL DESCRIPTION

MiniScribe III contains all necessary mechanical and electronic parts to interpret control signals, position the recording heads over the desired track, read and write data, and provide a contaminant free environment for the heads and disks.

3.1 READ/WRITE AND CONTROL ELECTRONICS

One integrated circuit is mounted within the sealed enclosure in close proximity to the read/write heads. Its function is to provide 1 of 2 head selection, read preamplification, and write drive circuitry.

The single microprocessor controlled circuit card provides the remaining electronic functions which include:

- Read/Write Circuitry
- Head Positioning
- Stepper Motor Drive
- Interface Control
- Index Detection
- Track Zero Detect
- Spin Speed Control
- Dynamic Braking

3.2 DRIVE MECHANISM

A brushless DC direct drive motor rotates the spindle at 3600 rpm. The motor/spindle assembly is dynamically balanced to provide minimal mechanical runout to the disks. A dynamic brake is used to provide a fast stop to the spindle motor when power is removed.

3.3 AIR FILTRATION SYSTEM

Within the sealed enclosure a 0.3 micron filter coupled with a breather filter, provides over the drive life a clean, above atmospheric pressure environment to the heads and disks.

3.4 HEAD POSITIONING MECHANISM

Two read/write heads are supported by a carriage mechanism coupled to the stepper motor through a rack-and-pinion motion translator. The rack-and-pinion translator allows for the increased number of data tracks while retaining the full step holding torque and positioning repeatability characteristics of the stepper motor.

3.5 READ/WRITE HEADS AND DISKS

Data is recorded on one 130 mm diameter disk through 2 low force, low mass Winchester type ferrite heads.

3.6 MECHANICALLY ISOLATED MOUNTING POINTS

Four side mounting and four base mounting points are provided to the customer. Each mounting point is mechanically isolated from the drive. The mounting brackets are compatible with MS I, MSII, and MS IV. Additionally, four side mounting points are provided that are compatible with a half height floppy disk.

3.7 TRACK ZERO DETECTOR

The Track Zero Detector resides on the stepper motor. This optical sensor consists of a light source (activated only when a seek is initiated) and a receiver which when blocked by an interrupter on the motor shaft indicates one of several logical Track Zero positions. The microprocessor determines the physical location of Track Zero from the redundant logical Track Zeros.

4.0 OPERATIONAL DESCRIPTION

4.1 POWER SEQUENCING

+5 volts DC and +12 volts DC may be applied in any order.

+12 VDC powers the spindle drive motor. The microprocessor verifies that the disks are spinning at 3600 rpm and then activates the automatic Track zero positioning. -Track ZERO, -SEEK COMPLETE, and -READY will become true upon completion of the Track zero positioning sequence. Refer to Figure 4-1 for the Power-Up Sequencing.

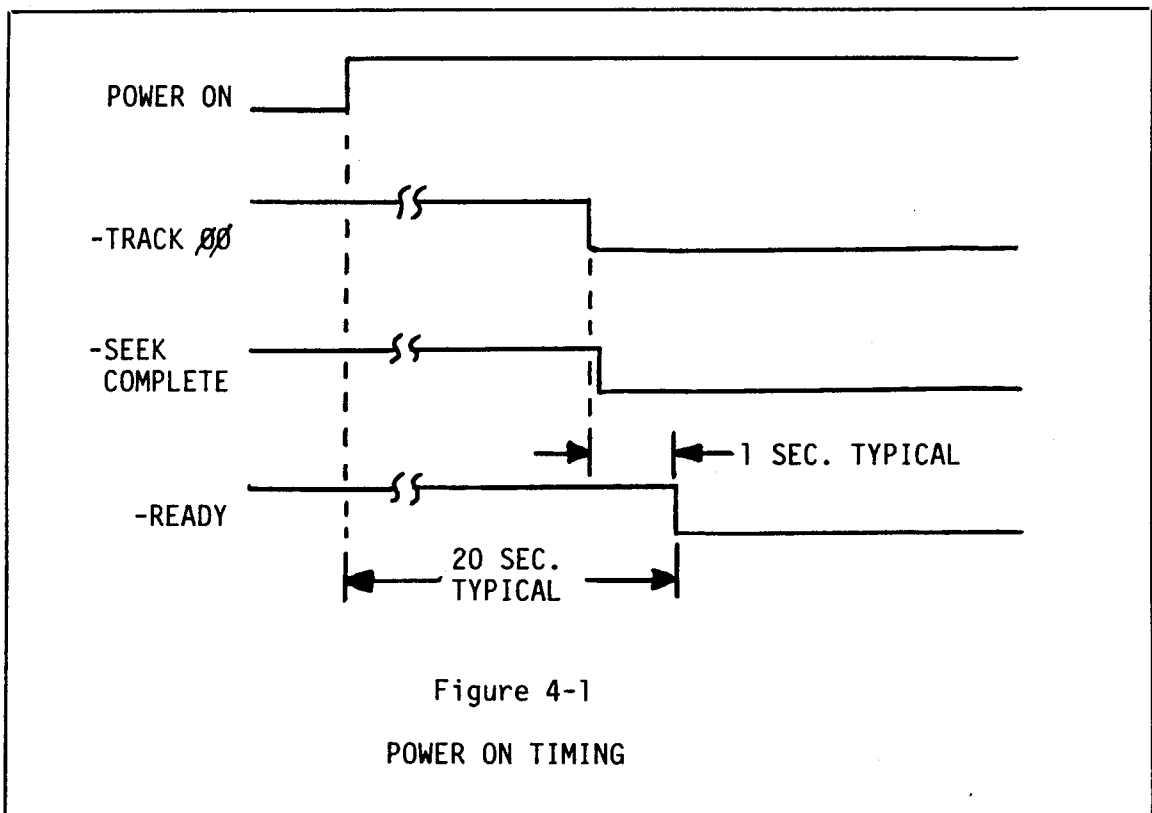

Figure 4-1

POWER ON TIMING

4.2 DRIVE SELECTION

Drive selection occurs when one of the -DRIVE SELECT signals is true. Only the drive selected will respond to Control Input Signals, and only that drive's Control Output Signals will be gated to the interface (see Paragraph 5.4.2. for the exception).

4.3 TRACK ACCESSING

Read/Write head positioning is accomplished by:

- o Setting -WRITE GATE false
- o Setting the appropriate -DRIVE SELECT true
- o Selected drive having -READY and -SEEK COMPLETE true
- o Setting the appropriate state of -DIRECTION IN
- o Pulsing the -STEP

Each -STEP pulse will cause the R/W heads to move either one track in or one track out, depending on the state of -DIRECTION IN. -DIRECTION IN true will cause the R/W head to move inward toward the spindle; -DIRECTION IN false will cause the R/W head to move outward toward Track zero. The drive will prevent any outward movement beyond Track zero regardless of the -STEP pulses.

A seek to cylinder 355 on the Model 3006 will position the heads over the shipping zone; for the Model 3012 seek to cylinder 656.

A seek to a higher cylinder than 656 will cause a recalibration sequence in the drive.

4.4 HEAD SELECTION

Either of the 2 heads can be selected by placing the heads binary address on the -HEAD SELECT 2^0 input line.

4.5 READ OPERATION

Reading the data from the drive is accomplished by:

- o Setting -WRITE GATE false
- o Setting the appropriate -DRIVE SELECT true
- o Selected drive having -READY and -SEEK COMPLETE true
- o Selecting the appropriate -HEAD SELECT binary address

4.6 WRITE OPERATION

Writing data to the drive is accomplished by:

- o Setting the appropriate -DRIVE SELECT true
- o Selected drive having -READY and -SEEK COMPLETE true
- o Selecting the appropriate -HEAD SELECT binary address
- o Assuring -WRITE FAULT is false
- o Setting -WRITE GATE true and placing the data to be written on the MFM WRITE DATA lines.

5.0 ELECTRICAL INTERFACE

The interface to the MiniScribe III can be divided into three categories each of which are physically separated: Control Signals, Data Signals and DC Power.

All Control Signals are digital in nature (open collector TTL) and either provide signals to the drive (input) or signals to the controller (output). The Data Signals are differential in nature and provide data either to (write) or from (read) the drive.

Table 5-1 provides the connector pin assignments for P1 and P2. The interconnect cable between the drive and controller may be flat ribbon or twisted pairs of a length not to exceed 20 feet. The signal return lines and ground lines for P1 and P2 should be grounded at the controller.

Table 5-1 also provides the connector pin assignments for P3. The voltage return lines of P3 should only be grounded at the power supply.

Connector P4 is a spade lug connector tied to frame ground.

The cable interconnection for a 4 drive system is defined in Figure 5-1.

5.1 CONTROL INPUT SIGNALS

The Control Input Signals are gated into the drive by the activation of the appropriate - DRIVE SELECT line. (See Paragraph 5.4.2 for exception). Refer to Figure 5-2 for the driver/receiver circuit and signal level specification. Each Control Input Signal is terminated by a 220/330 ohm resistor network in the drive.

5.1.1 REDUCED WRITE CURRENT

This line is non-functional on the MiniScribe III. Write current is controlled by the internal microprocessor.

Table 5-1

P1/P2/P3/P4 CONNECTOR PIN ASSIGNMENT

Signal	Ground Return	Signal Name
P1-2	P1-1	Reserved
P1-4	P1-3	Reserved
P1-6	P1-5	-Write Gate
P1-8	P1-7	-Seek Complete
P1-10	P1-9	-Track Zero
P1-12	P1-11	-Write Fault
P1-14	P1-13	-Head Select 2 ^o
P1-16	P1-15	Reserved
P1-18	P1-17	Reserved
P1-20	P1-19	-Index
P1-22	P1-21	-Ready
P1-24	P1-23	-Step
P1-26	P1-25	-Drive Select 1
P1-28	P1-27	-Drive Select 2
P1-30	P1-29	-Drive Select 3
P1-32	P1-31	-Drive Select 4
P1-34	P1-33	-Direction In
P2-1	P2-2	-Selected
P2-3	P2-4	Reserved
P2-5	P2-6	Spare
P2-7	P2-8	Reserved
P2-9		Spare
P2-10		Spare
P2-11	P2-12	Ground
P2-13		+MFM Write Data
P2-14		-MFM Write Data
P2-15	P2-16	Ground
P2-17		+MFM Read Data
P2-18		-MFM Read Data
P2-19	P2-20	Ground
P3-1		+12 Volts DC
P3-2		+12 Volts DC Return
P3-3		+5 Volts DC Return
P3-4		+5 Volts DC
P4		Frame Ground

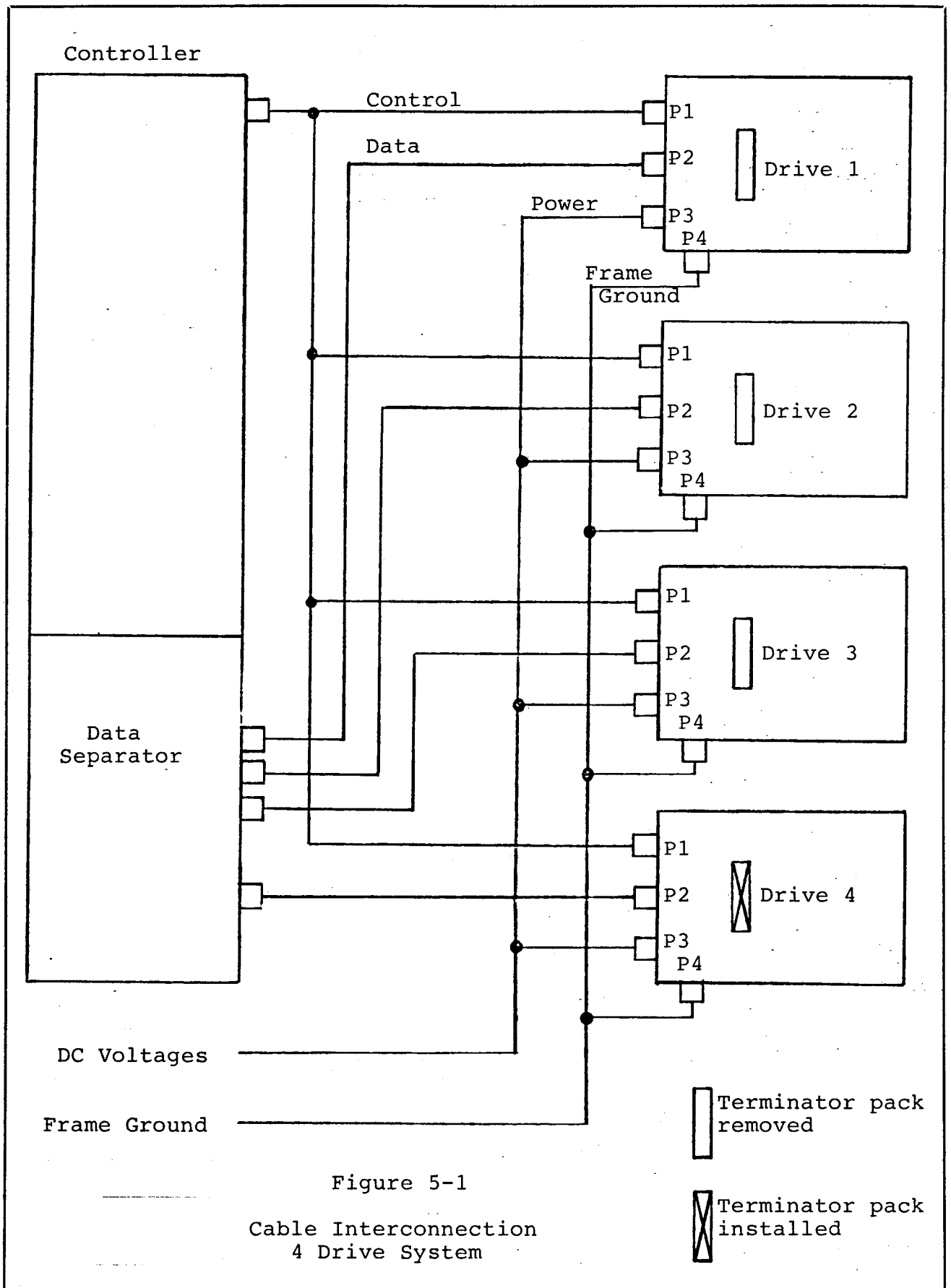

Figure 5-1
Cable Interconnection
4 Drive System

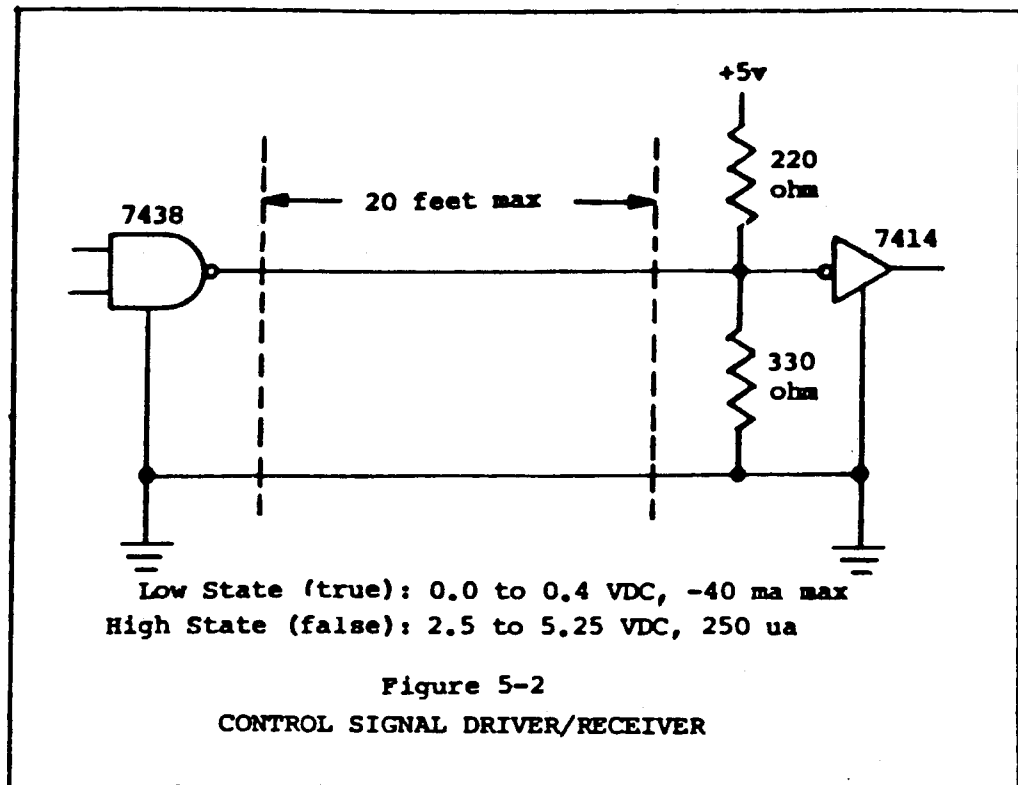

Figure 5-2
 CONTROL SIGNAL DRIVER/RECEIVER

5.1.2 -WRITE GATE

The true state of this signal enables write data to be written on the disk. The false state of this signal enables data to be transferred from the drive.

5.1.3 -HEAD SELECT 2⁰
 -Head Select 2⁰ signal provides for the selection of one of the two Read/Write Heads. -Head Select 2⁰ being false will select Head 0, and being true will select Head 1.

5.1.4 -DIRECTION IN

This signal defines direction of motion of the R/W head when the -STEP line is pulsed. A high level defines the direction as "out" and if a pulse is applied to the -STEP line the R/W heads will move away from the center of the disk. If this line is a low level the direction of motion is defined as "in" and the step pulses will cause the R/W heads to move toward the center of the disk. Change in direction must meet the requirements shown in Figure 5-3.

5.1.5 -STEP

This control signal causes the R/W head to move with the direction defined by the -DIRECTION IN line.

The drive is able to accept step pulses in two modes, track-to-track and buffered. In the track-to track mode, step pulses should be sent at a 3 ms rate or greater to access the desired track. In the buffered mode, step pulses must be sent at a 6 us to 200 us rate. In this mode, pulses are accumulated until no new pulses have been received for 200 us. At this point access motion is initiated, and an optimized seek algorithm is executed to minimize access time. Pulses that occur after this time and prior to completion of the seek, will be ignored. The drive automatically decides which mode to use based on the incoming step pulse rate. The direction line should be maintained at the desired level 100 ns before the first step pulse until 100 ns after the last step pulse has been issued. See Figure 5.3 for timing diagram.

5.1.6 -DRIVE SELECT 1,2,3 AND 4

-DRIVE SELECT, when low, connects the drive to the control lines. Cutting the appropriate shunts on the Printed Circuit Card (See Paragraph 5.4.1) will determine which select line on the interface will activate the drive. (See Paragraph 5.4.2 for the exception.)

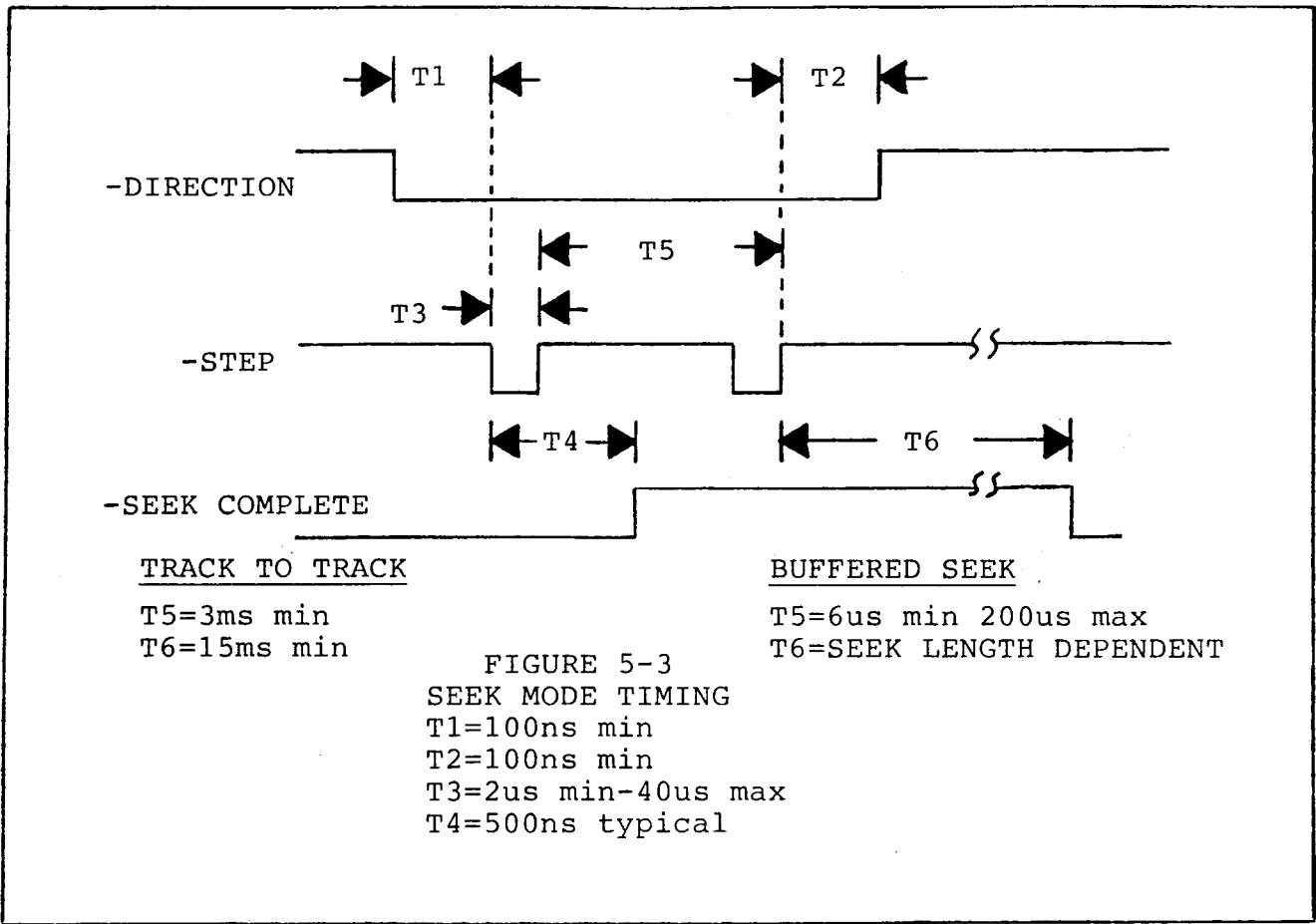

5.2 CONTROL OUTPUT SIGNALS

The Control Output Signals are gated from the drive by the activation of the appropriate -DRIVE SELECT line. (See Paragraph 5.4.2 for the exception.) Refer to Figure 5-2 for the driver/receiver circuit and signal level specifications. Each Control Output Signal should be terminated in the controller with a 220/330 ohm resistor network.

5.2.1 -SEEK COMPLETE

This signal will go true when the R/W heads have settled on the final track at the end of a seek. Reading or writing should not be attempted when -SEEK COMPLETE is false.

-SEEK COMPLETE will go false if a recalibration sequence is initiated (by drive logic) at power on, or 500ns (typical) after the leading edge of a step pulse.

5.2.2 -TRACK ZERO

This interface signal indicates a true state only when the drive's R/W heads are positioned at Track Zero (the outermost data track).

5.2.3 -WRITE FAULT

This signal is used to indicate a condition exists in the drive which will result in improper writing on the disk. When this signal is true, further writing is inhibited at the drive until the condition is corrected. Once corrected the controller can reset this line by deselecting the drive. Any of the following four conditions could cause -WRITE FAULT to be true.

1. No write current sensed in the head with -WRITE GATE active and -DRIVE SELECTED.
2. An open head in the drive.
3. No transitions on MFM WRITE DATA line when -WRITE GATE true.
4. DC voltages are out of tolerance.

5.2.4 -INDEX

This 100 microsecond (typical) interface pulse is provided by the drive once each revolution (16.67ms nominal) to indicate the beginning of the track. Normally, this signal is a high level and makes the transition to the low level to indicate -INDEX. Only the transition from high to low is valid.

5.2.5 -READY

This interface signal when true together with -SEEK COMPLETE, indicates that the drive is ready to read, write or seek, and that the I/O signals are valid. When this signal is false, all writing and seeking are inhibited.

The typical time after power on for -READY to be true is 20 seconds.

5.2.6 -DRIVE SELECTED

The -DRIVE SELECTED signal will go true only when the drive is programmed as drive X (X=1,2,3, or 4) and the -DRIVE SELECT X line is activated by the controller. (See Paragraph 5.4.2 for the exception.)

5.3 DATA TRANSFER SIGNALS

All signals associated with the transfer of data between the drive and the controller are differential in nature and are gated by -DRIVE SELECT except in the radial mode (See Paragraph 5.4.2).

Two pairs of balanced signals are used for the transfer of data: MFM WRITE DATA and MFM READ DATA. Figure 5-4 illustrates the driver/receiver combination used in the MiniScribe III for data transfer signals.

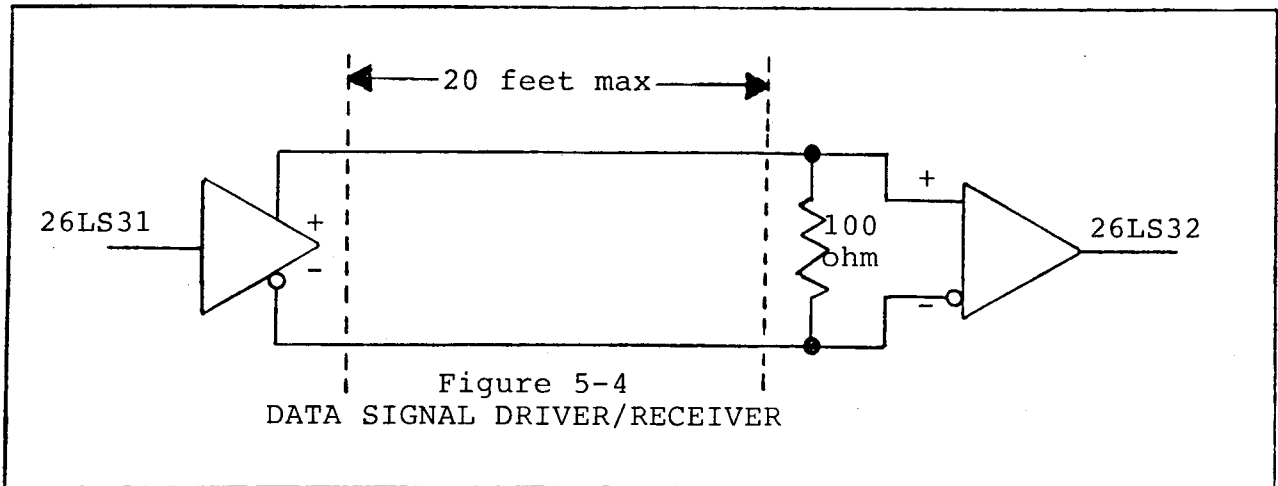

5.3.1 MFM WRITE DATA

This is a differential pair that defines the transitions to be written on the track. The transition of +MFM WRITE DATA line going more positive than the -MFM WRITE DATA line will cause a flux reversal on the track provided -WRITE GATE is true. The timing of the write operation is illustrated in Figure 5-5.

In MFM recording, to optimize data integrity and meet the error rate specified, the write data presented by the controller may be precompensated on all tracks, but must be precompensated from track 128 through track 306 on the Model 3006, and from track 128 through track 612 on the Model 3012. + MFM Write Data pulses bounded on one side by a 200 ns period ($1/2F$) and bounded on the other side by 300ns ($1/1.5F$) or 400 ns ($1/F$) period must be precompensated by 12ns towards the side of the 200ns ($1/2F$) period. The precompensation is illustrated in Table 5.2.

Table 5-2
WRITE PRE-COMPENSATION RULES

Bit				Compensation
1	2	3	4	
1	0	0	0	12nsec late on first clock
0	0	0	1	12nsec early on second clock
0	1	1	x	12nsec late on first data
1	1	0	x	12nsec early on second data

5.3.2 MFM READ DATA

The data recovered by reading a pre-recorded track is transmitted to the controller via the differential pair of MFM READ DATA lines. The transition of the +MFM READ DATA line going more positive than the -MFM READ DATA line represents a flux reversal on the track of the selected head. The timing of the read operation is illustrated in Figure 5-5.

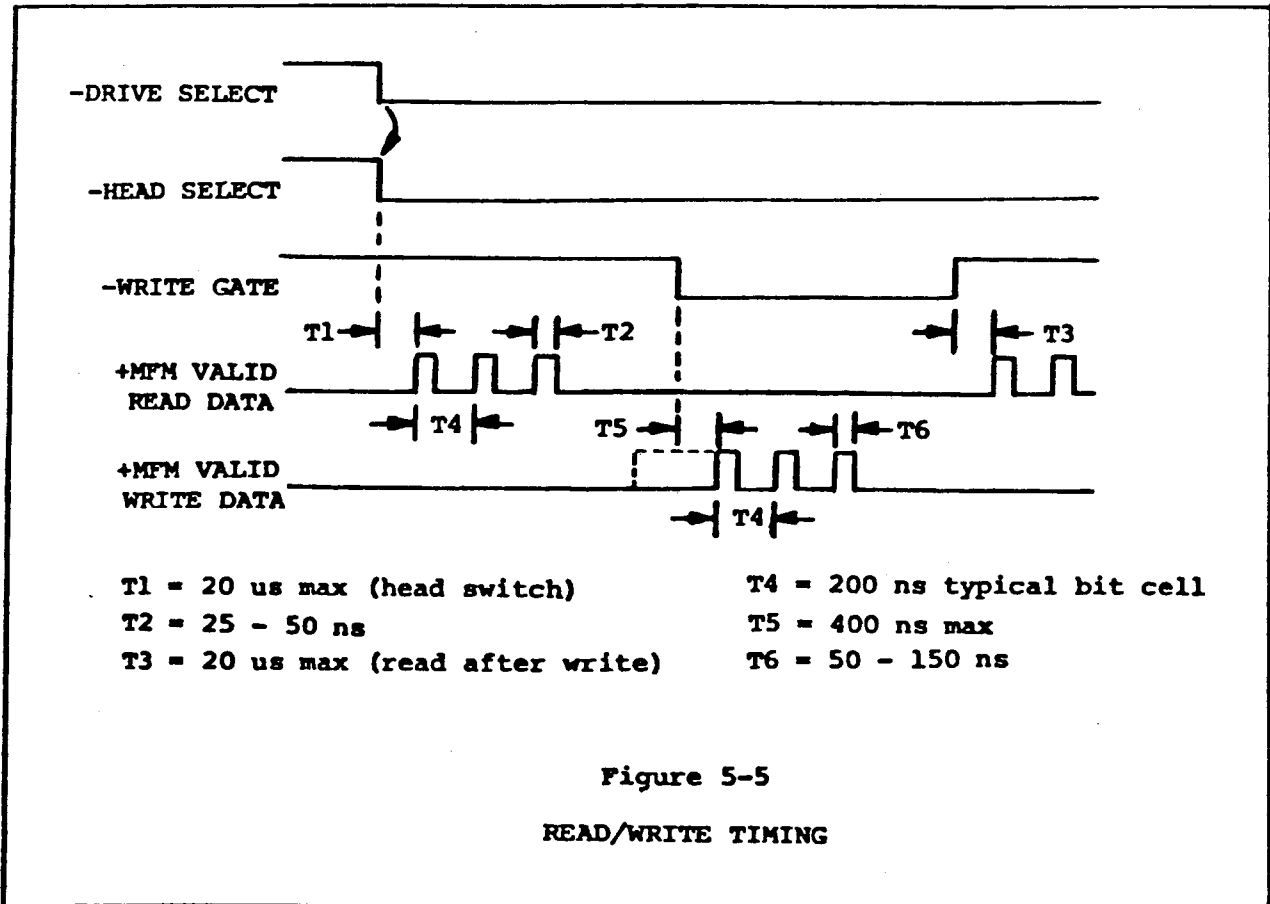

5.4 CUSTOMER OPTIONS

Customer optional features are implemented via a shunt block on the Printed Circuit Card. See Figure 2-1 for the location of the shunt block and the position of pin 1. See Figure 5-6 for the layout of the shunt block.

5.4.1 -DRIVE SELECT

As shipped, the 16-pin shunt block has drive select pin pairs shorted with the "Radial" option selected (see Paragraph 5.4.2). To select the desired drive number in a daisy-chain operation, refer to Table 5-3.

Table 5-3
DRIVE SELECTION CONFIGURATION

<u>Pin</u>	<u>Pair</u>	<u>DRIVE SELECT NUMBER</u>			
		<u>1</u>	<u>2</u>	<u>3</u>	<u>4</u>
8	- 9	short	open	open	open
7	- 10	open	short	open	open
6	- 11	open	open	short	open
5	- 12	open	open	open	short
1	- 16	open	open	open	open

5.4.2 "RADIAL" OPTION

As shipped, the 16-pin shunt block has pin pair 1/16 shorted resulting in a radial operation. In this case, all input and output signals are enabled, even if the drive is not selected. However, the front panel LED will not be on. -DRIVE SELECT must be active to light the LED. When pin pair 1/16 is open the drive is in a daisy chain mode where input and output signals are enabled when the appropriate -DRIVE SELECT line is activated.

5.4.3 DRIVE EXERCISE OPTION

As shipped, the 16-pin shunt block has pin pair 2/15 open. This shunt when shorted will initiate drive exercise routines. (Refer to Chapter 10.)

5.5 TERMINATORS

Each drive is shipped with a terminator pack providing the 220/330 ohm termination for the Control Input Signals. If multiple drives are configured in a daisy chain configuration (see Figure 5-1), the terminator pack must be removed from all drives except the last unit on the daisy chain. Figure 2-1 shows the location of the terminator pack.

5.6 ERROR MESSAGES

The microprocessor performs wake up diagnostics on power up. Additionally, some operations are monitored during normal operations. If an error is detected, the microprocessor will flash a warning by blinking the activity LED. An explanation of the diagnostics and error codes is defined in Chapter 10.

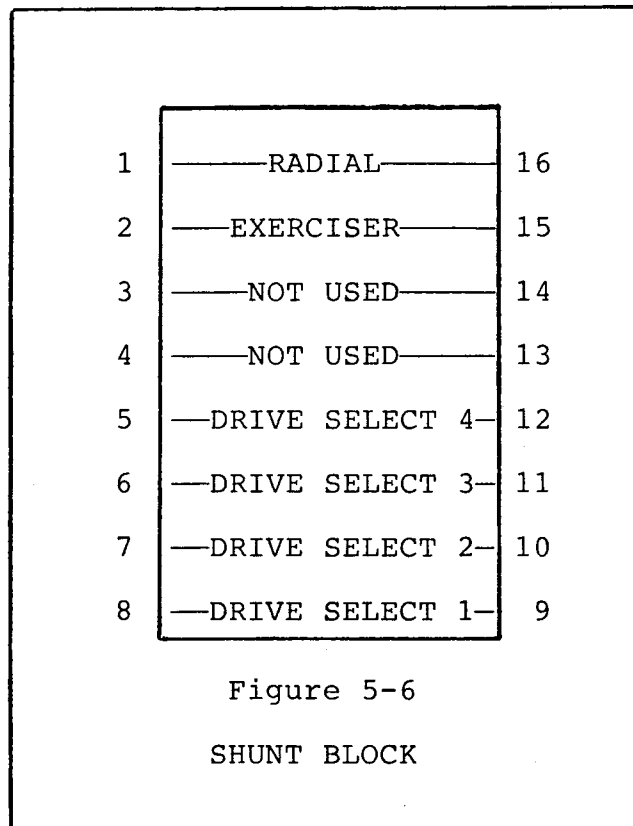

6.0 PHYSICAL INTERFACE

The electrical interface between the disk drive and the host controller and DC power supply is via four connectors: P1-Control Signals, P2 - Read/Write Signals, P3-DC Power input and P4-Frame Ground.

Refer to Figure 2-1 for connector locations.

6.1 J1/P1 CONNECTOR - CONTROL SIGNALS

Connection to P1 is through a 34 pin PCB edge connector. The dimensions for this connector are shown in Figure 6-1. The pins are numbered 1 through 34 with the odd pins located on the component side of the Printed Circuit Card. A key slot is provided between pins 4 and 6.

The recommended mating connector (P1) is AMP Ribbon Connector P/N 88373-3.

6.2 J2/P2 CONNECTOR - DATA SIGNALS

Connection to P2 is through a 20 pin edge connector. The dimensions for the connector are shown in Figure 6-1. The pins are numbered 1 through 20 with the odd pins located on the component side of the Printed Circuit Card. A key slot is provided between pins 4 and 6.

The recommended mating connector (P2) is AMP Ribbon Connector P/N 88373-6.

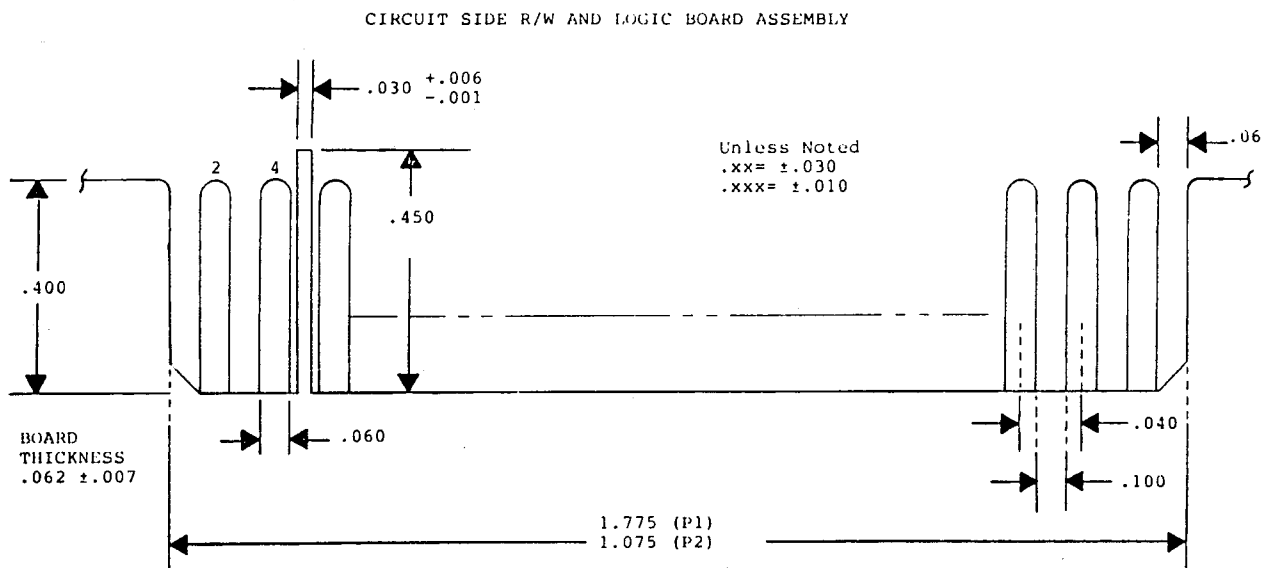
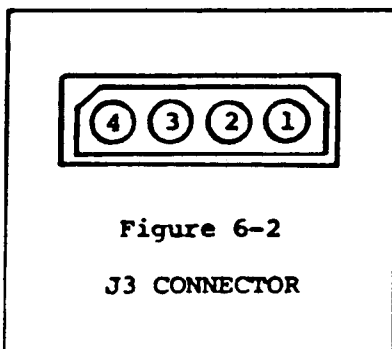

FIGURE 6-1
P1/P2 CONNECTOR

6.3 J3/P3 CONNECTOR - DC POWER

DC power connector (P3) is a 4 pin AMP Mate-N-Lok connector, mounted on the PCB. P3 pins are numbered as shown in Figure 6-2.

The recommended mating connector (P3) is AMP P/N 1-480424-0 utilizing AMP pins P/N 350078-4.



6.4 J4/P4 CONNECTOR - FRAME GROUND

Faston AMP P/N 61761-2

Recommended mating connector is AMP 62187-1.

If used, the hole in P4 will accommodate a wire size of 18AWG max.

7.0 TRACK FORMATTING GUIDELINES

The purpose of a format is to organize a track into smaller addressable records called sectors. The MiniScribe III is a soft sectored device allowing the customer to define the sector format. When establishing the track format certain rules should be observed to accommodate the physical timing relationships within the drive.

7.1 GAP 1

If head switching occurs at index time, then, to reliably read the content of the first sector, Gap 1 must be provided to allow the read amplifier to stabilize. The minimum length of Gap 1 is 12 bytes.

7.2 SYNC

A sync field precedes each addressable record (ID or record) and should be of a length to accommodate the "lock up" characteristics of the phase-lock-loop within the data separator portion of the customer's controller.

7.3 GAP 2

Following each sector it is recommended a gap be placed to accommodate spindle speed variations between write operations on the same track to insure that overwrite will not occur on adjacent recorded data. To accommodate the $\pm 1\%$ speed tolerance of the disk drive, Gap 2 should be a minimum of 1 byte for each 32 bytes of data within the sector. Additionally the customer should increase the gap to accommodate the spin speed-asynchronous frequency variation of the controller generated MFM WRITE DATA signals.

7.4 GAP 3

This gap is a speed tolerance buffer for the entire track to insure that the last sector does not overflow beyond the index. Gap 3 precedes index and should be of a length to accommodate the spin speed variations of the disk drive ($\pm 1\%$) and the frequency variations of the controller generated MFM WRITE DATA signals.

8.0 INSTALLATION

CAUTION/WARNING

The MiniScribe III is a precision product weighing 3.5 pounds. During handling, the unit must not be dropped, jarred or bumped. Otherwise damage to the heads and disks may occur.

8.1 UNPACKING AND INSPECTION

8.1.1 SINGLE PACK

Retain the packing materials for reuse. Refer to Figure 8-1 for the following steps:

- Step 1: Inspect the shipping container for evidence of intransit damage. If damage is evident, notify the carrier immediately.
- Step 2: Open the outer carton by carefully cutting the tape on the top of the carton.
- Step 3: Lift the inner carton out of the outer carton and remove the end foam cushions.
- Step 4: Open the inner carton by carefully cutting the tape on the top of the carton.
- Step 5: Lift the drive from the inner carton and remove the end foam cushions and the cardboard wrap with spacer.
- Step 6: Place the two pairs of end cushions, the cardboard wrap with spacer and the inner carton within the outer carton and store for subsequent use.
- Step 7: Inspect the drive for shipping damage, loose screws or components and correct if possible. If damage is evident without noticeable damage to the shipping cartons, notify MiniScribe immediately for drive disposition.

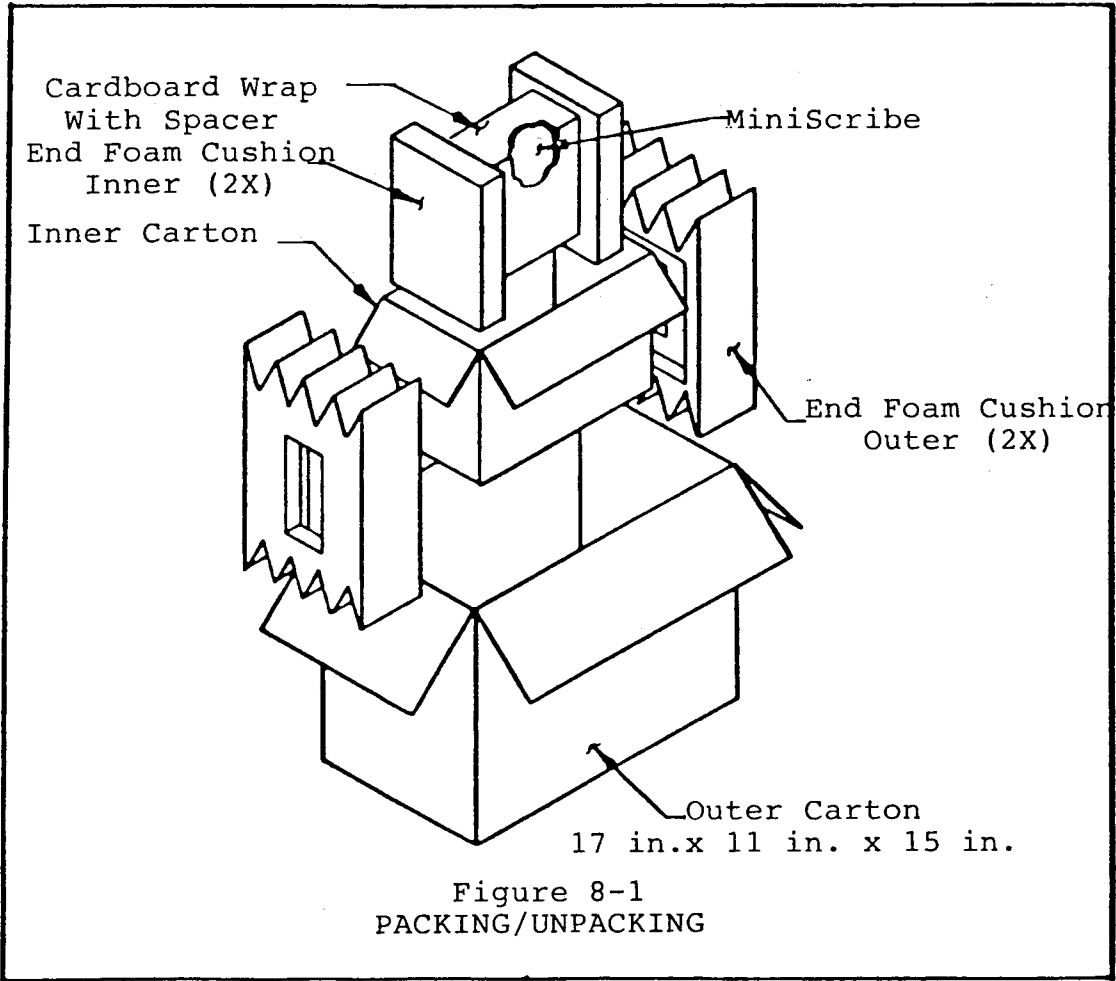

8.1.2 6 PACK

Retain the Packing Materials for reuse. Refer to Figure 8.2 for the following steps:

- Step 1: Inspect the shipping container for evidence of intransit damage. If damage is evident, notify the carrier immediately.
- Step 2: Lift off outer carton top.
- Step 3: Lift off upper foam cushion. This will expose the six drives in their cardboard wrap.
- Step 4: Lift each drive out of the lower foam cushion individually and remove the cardboard wrap with spacer.
- Step 5: Return cardboard wrap with spacer to lower foam cushion for reuse.
- Step 6: Place drive on a protective foam pad and inspect the drive for shipping damage, loose screws or components and correct if possible. If damage is evident without noticeable damage to the shipping carton, notify MiniScribe immediately for drive disposition.
- Step 7: Once all 6 drives have been removed from the shipping carton and the cardboard wraps with spacers have been returned to the lower foam cushion, reassemble the carton and store for reuse.

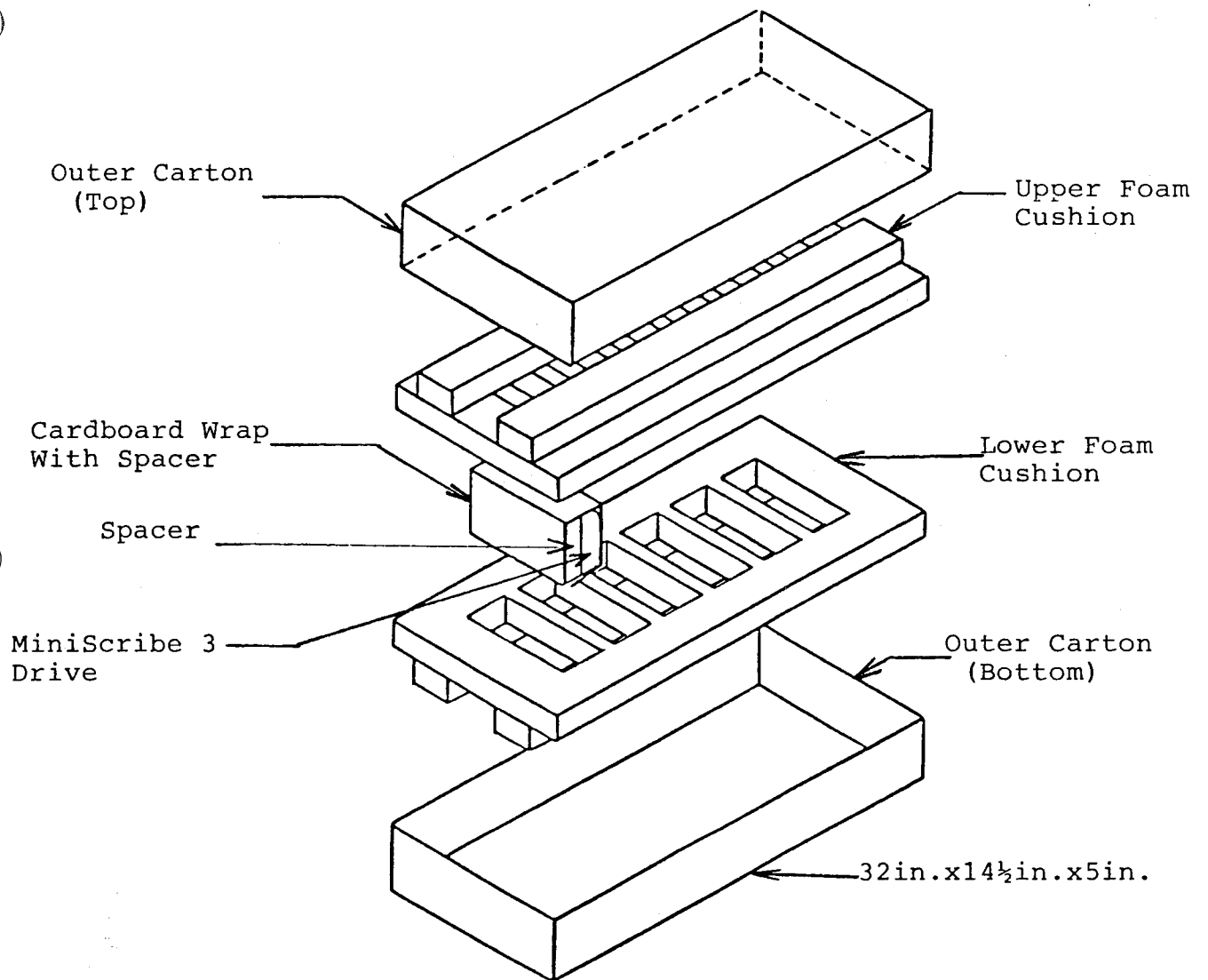

Figure 8-2
6 Pack Multipack Shipping Container

8.2 REPACKING

Should the MiniScribe Drive require shipment, repack the drive using the MiniScribe packing materials following the Steps in paragraph 8.1.1 SINGLE PACK or paragraph 8.1.2 6 PACK in reverse order.

The MiniScribe series contain shipping zones for protection of the data areas from periods of mishandling. Prior to power down for shipment, the host controller should access this zone (See Paragraph 4.3).

NOTICE

The MiniScribe Drive product warranty is void if the drive is returned to MiniScribe in other than the standard MiniScribe shipping carton packed in accordance with the enclosed procedure.

It should also be noted that the MiniScribe drive product warranty is void if the 6 pack multipack shipping container is not shipped on a pallet.

8.3 CONFIGURATION

The customer should determine the drive select number required and the options desired and configure the 16-pin shunt as defined in Paragraph 5.4.

8.4 RECOMMENDED MOUNTING CONFIGURATION

The MiniScribe III half height drive is designed to be used in applications where the unit may experience shock and vibrations at greater levels than larger and heavier disk drives.

Two features which allow greater shock tolerance are the use of plated media, and shock mounts. To take full advantage of the shock mounts, however, it is necessary to provide a 0.1 inch clearance on both the top and bottom of the drive. This clearance allows for movement of the drive during acceleration. This implies that if the drive is mounted by the bottom mounting holes on a flat surface, standoffs are needed under the mounting holes. No special consideration is required if the drive is mounted using the side mounts except for the clearance on top and bottom. The drive may be mounted in any attitude except upside down.

The drive is mounted using 6-32 Unctap screws, 1/4 inch maximum penetration. See Figure 2-1 for mounting dimensions. The customer should allow adequate ventilation to the drive to insure reliable drive operation over the operating temperature range.

8.5 CABLING

Connect interface cables with connectors P1, P2, P3 and P4 to J1, J2, J3, and J4 respectively. Insure connectors P1 and P2 have keys installed as indicatd in Figure 6-1. If multiple drives are to be interconnected, remove the terminator packs in all but the last drive in the daisy chain. See Figure 2-1 for the terminator pack location.

9.0 PRINTED CIRCUIT CARD REPLACEMENT (See Figure 9-1)

CAUTION!

The MiniScribe Drive is a precision product weighing 3.5 pounds. During handling the unit must not be dropped, jarred or bumped. Otherwise, damage to the heads and disk may occur. When the drive is not properly mounted, it is recommended that it be placed on a protective foam pad.

- Step 1: Seek the heads to the shipping zone (See Paragraph 4.3). Disconnect the cables and remove the mounting screws. Move the disk to a convenient work station, and place on a foam pad with the Printed Circuit Card up.
- Step 2: Remove the decorator cover and disconnect the LED.
- Step 3: Carefully remove the flex lead connector. Do not pull on the flex lead, instead grasp the connector on the sides and slide it off the pins.
- Step 4: Remove the five screws holding the card to the baseplate.
- Step 5: Disconnect all remaining connectors (refer to Figure 9.1).
- Step 6: Install the new card by reversing the above steps. Ensure the connectors are properly mated and the cables are not touching the spin motor.
- Step 7: Move the terminator (if installed) and the shunt block from the old card to the new one. (Ref. to figure 2-1) Remount and cable the drive in the system.

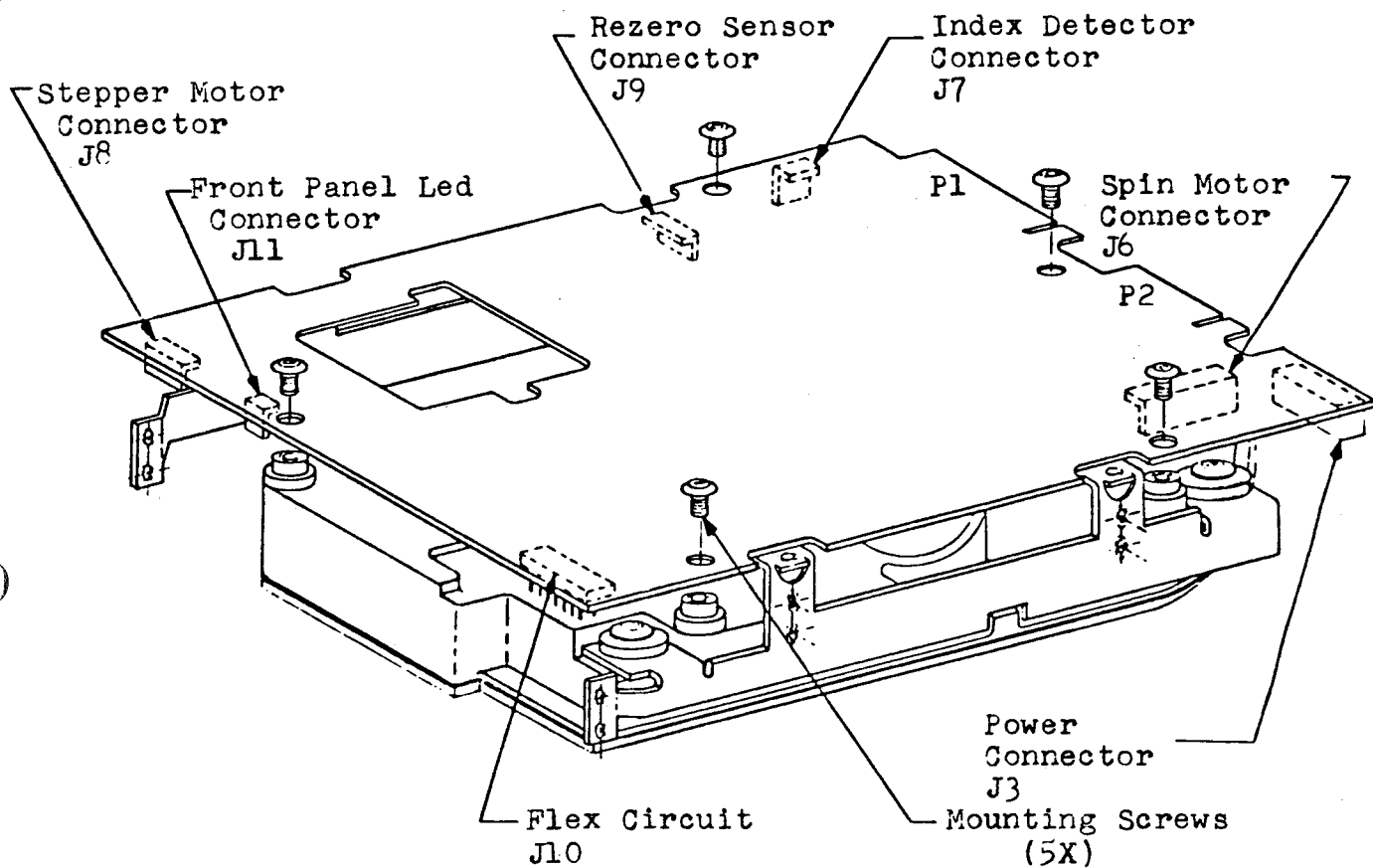

FIGURE 9-1
 Board Replacement

10.0 Diagnostic and Exercise Routines

This section covers the diagnostic and exercise routines for the MiniScribe III. A simplified flow chart is included to define the routines and the steps at which errors might occur. Error indications are explained as well as a method for parking the heads at the shipping zone.

10.1 General Description

The microprocessor performs "wake up" diagnostics upon application of power. If an error is detected, the processor will flash a warning by blinking the Activity LED. Some errors are fatal in that they do not return to the program until power is cycled (refer to the Flow Chart).

If no errors are detected, the processor tests the shunt block to determine the state of pin pair 2/15 (drive exercise option).

If pin pair 2/15 is open, the drive will become ready. During normal operation, the drive will continue to monitor some functions such as spin speed and indicate an error if it occurs.

If pin pair 2/15 is shorted, the drive will enter the exerciser routine.

The drive then does a seek to the shipping zone and turns the LED on solid. The heads will remain at the shipping zone for 5 seconds during which time the drive can be powered down for shipment. At the end of the 5 second period the drive will initiate an actuator exercise routine which does a random seek for approximately 5 days.

10.2 Message Readout

The processor will display messages by flashing a "morse-code" type hexadecimal character via the Activity LED. The flashing sequence is a combination of long and short periods of LED ON cycles. The timing for each period is as follows:

- Zero = 0.1 second ON
- One = 0.6 second ON
- Between Bits = 0.6 seconds OFF
- Between Repeat Cycles = 2.0 seconds OFF

Below is listed the binary to hexadecimal conversion values:

0=0000	4=0100	8=1000	C=1100
1=0001	5=0101	9=1001	D=1101
2=0010	6=0110	A=1010	E=1110
3=0011	7=0111	B=1011	F=1111

Example: Code "E"

0.6 Sec ON
0.6 Sec OFF
0.6 Sec ON
0.6 Sec OFF
0.6 Sec On
0.6 Sec OFF
0.1 Sec ON
2.0 Sec OFF

10.3 Message Definitions

Code 0 - Microprocessor RAM error
Code 1 - EPROM checksum error
Code 5 - Unable to detect motor spinning
Code 6 - Spin motor failed margin test
Code 7 - Unable to maintain spin speed
Code 8 - Unable to uncover Track 00 sensor
Code 9 - Unable to cover Track 00 sensor
Code A - Interrupter Phase Error (factory phase adjust)

10.4 Shipping Zone

The shipping zone can be accessed by seeking to it (refer to paragraph 4.3) or by utilizing the following procedure:

1. Initiate the exercise routine by shorting the shunt block pair 2-15, and applying D.C. power.
2. After the heads have reached the shipping zone, the LED will turn on solid for 5 seconds. During the 5 second period remove the D.C. power.
3. Open shunt pair 2-15.

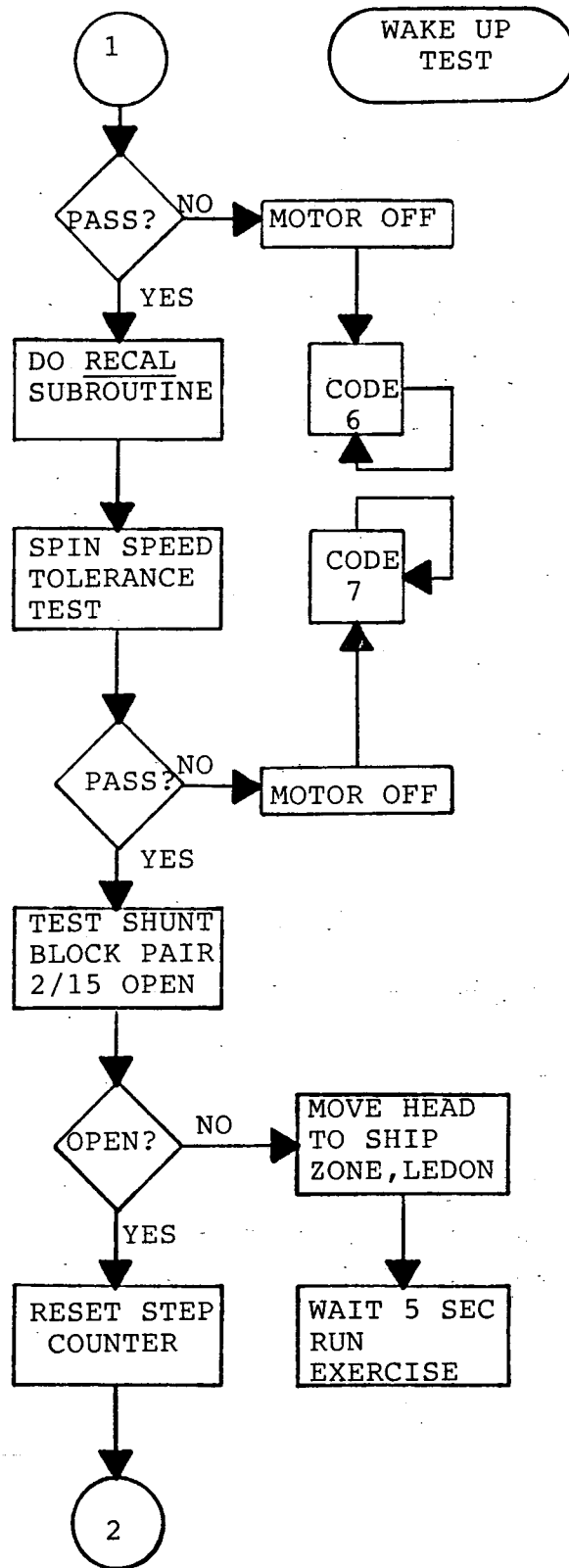
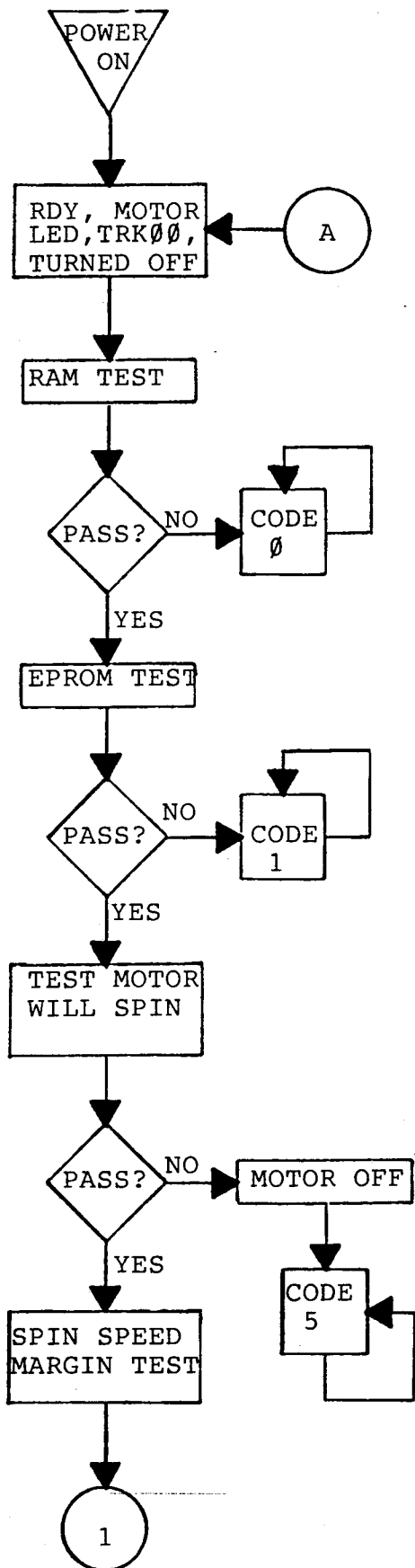

WAKE UP TEST

MAIN PROGRAM LOOP

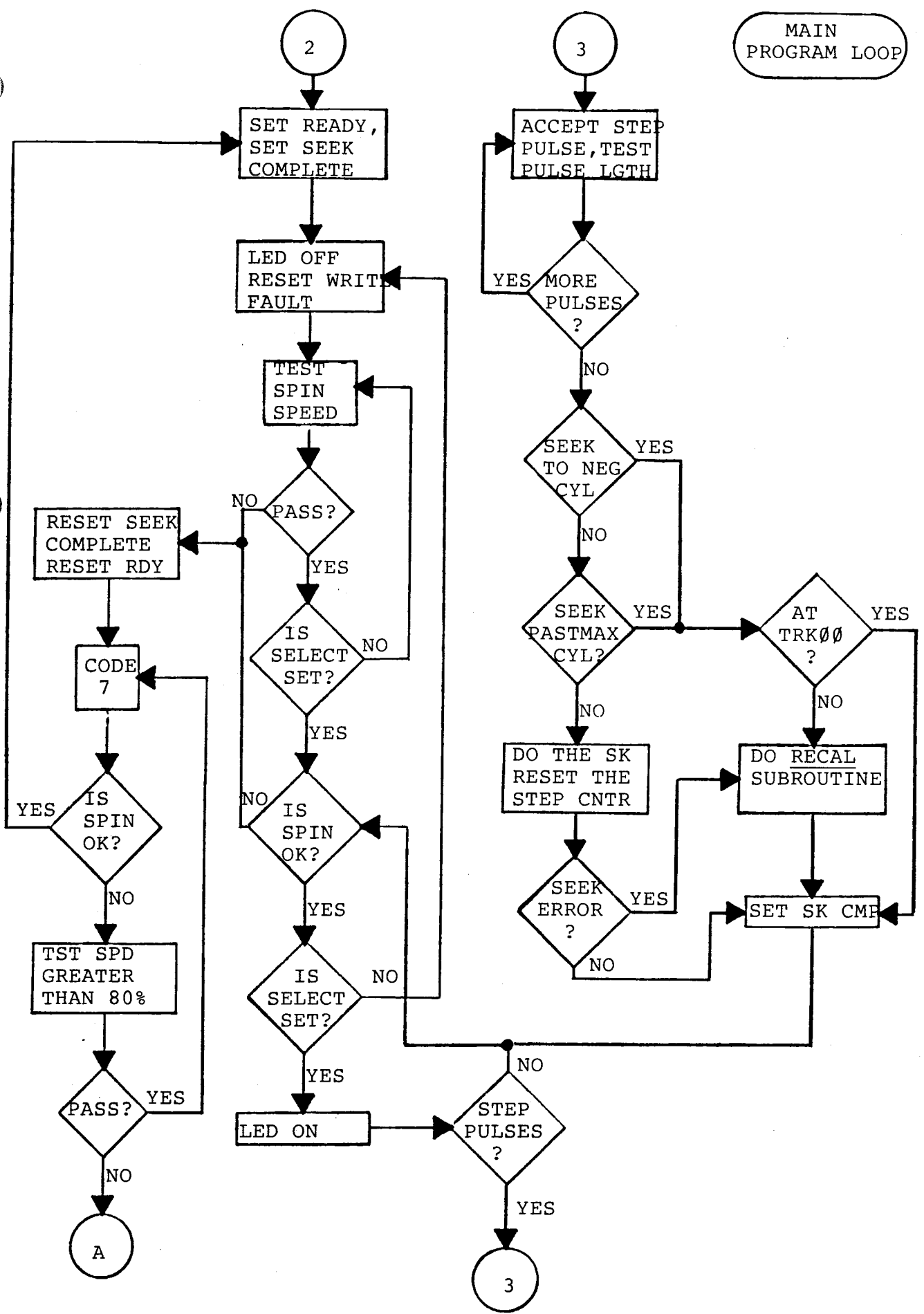

RECAL
SUBROUTINE

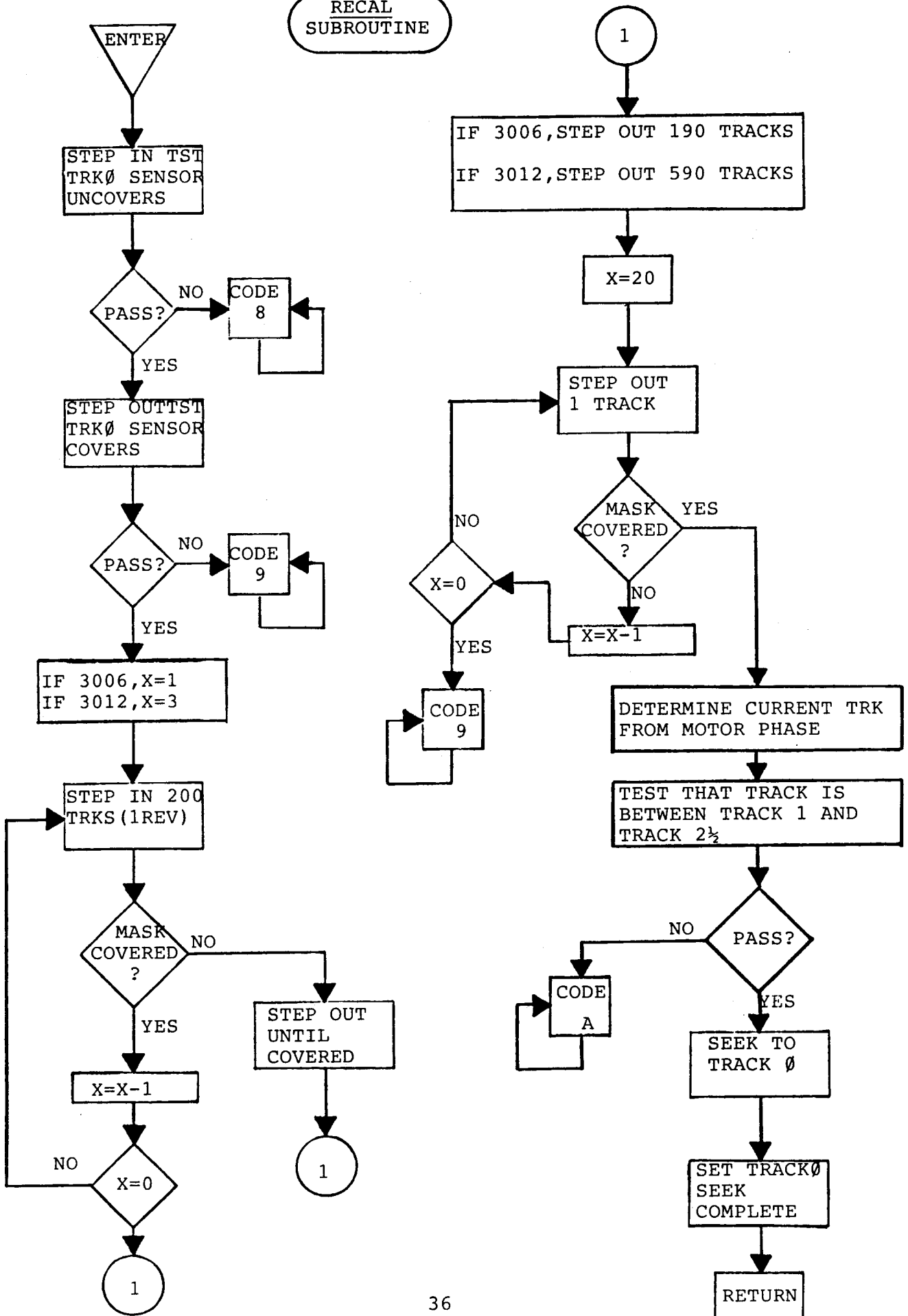

RETURN LETTER

Title: RC750 Winchester disk
OEM Manual, WDD703

RCSL No.: 991 09823

A/S Regnecentralen af 1979/RC Computer A/S maintains a continual effort to improve the quality and usefulness of its publications. To do this effectively we need user feedback, your critical evaluation of this manual.

Please comment on this manual's completeness, accuracy, organization, usability, and readability:

Do you find errors in this manual? If so, specify by page.

How can this manual be improved?

Other comments?

Name: _____ Title: _____

Company: _____

Address: _____

Date: _____

Thank you

RCSL Nr. 46-F 0093

..... **Fold here**

..... **Do not tear - Fold here and staple**

**Affix
postage
here**

E **REGNECENTRALEN**
af 1979

**Information Department
Lautrupbjerg 1
DK-2750 Ballerup
Denmark**