

IBM System/3  
Model 15  
Operator's Guide

GC21-5075-3  
File No. S3-40



**IBM System/3  
Model 15  
Operator's Guide**

## Preface

This manual provides the information you need to operate the IBM System/3 Model 15. The manual is divided into three parts:

- *Part 1. Device Operation* – which describes operating procedures for the Model 15 devices.
- *Part 2. System Operation* – which describes how to operate the Model 15 and its devices as a system. It describes functions of the system and how you can communicate with the system to obtain the desired results.
- *Part 3. Program Operation* – which describes general procedures for compiling and executing programs and system service functions.

You must be familiar with *Part 1. Device Operation* before using Parts 2 and 3 of this manual.

*Note:* This manual follows the convention that “he” means “he or she.”

## Prerequisite Publication

In order to understand and use this publication, you must be familiar with *IBM System/3 Model 15 Introduction*, GC21-5094. For a list of manuals that contain additional information about the IBM System/3 Model 15, see the *Bibliography* at the back of this book.

## Fourth Edition (September 1978)

This is a major revision of, and obsoletes, GC21-5075-2 and technical newsletters GN21-5553 and GN21-5577. Changes or additions to the text and illustrations are indicated by a vertical line to the left of the change or addition.

This edition applies to the following IBM System/3 system control programs and to all subsequent versions and modifications until otherwise indicated in new editions or technical newsletters.

<i>Version</i>	<i>Modification</i>	<i>Program Number</i>	<i>Model</i>
6	0	5704-SC1	15 A-B-C
3	0	5704-SC2	15D

Changes are periodically made to the information herein; before using this publication in connection with the operation of IBM systems, refer to the latest *IBM System/3 Bibliography*, GC20-8080, for the editions that are applicable and current.

Use this publication only for the purposes stated in the *Preface*.

Publications are not stocked at the address below. Requests for copies of IBM publications and for technical information about the system should be made to your IBM representative or to the branch office serving your locality.

This publication could contain technical inaccuracies or typographical errors. Address your comments about this publication to IBM Corporation, Publications, Department 245, Rochester, Minnesota 55901. IBM may use and distribute any of the information you supply in any way it believes appropriate without incurring any obligation whatever. You may, of course, continue to use the information you supply.



# Technical Newsletter

This Newsletter No. GN21-5661  
Date 29 December 1978  
Base Publication No. GC21-5075-3  
File No. S3-40  
Previous Newsletters None

## IBM System/3 Model 15 Operator's Guide

© IBM Corp. 1974, 1976, 1977, 1978

This technical newsletter applies to version 7, modification 0 of IBM System/3 Model 15 System Control Program (Program Number 5704-SC1) and provides replacement pages for the subject publication. These replacement pages remain in effect for subsequent versions and modifications unless specifically altered. Pages to be inserted and/or removed are:

13, 14  
171, 172

Changes to text and illustrations are indicated by a vertical line at the left of the change.

### Summary of Amendments

Miscellaneous technical changes

*Note:* Please file this cover letter at the back of the manual to provide a record of changes.

IBM Corporation, Publications, Department 245, Rochester, Minnesota 55901

© IBM Corp. 1978

Printed in U.S.A.





# Technical Newsletter

This Newsletter No. GN21-5671  
Date 28 September 1979  
Base Publication No. GC21-5075-3  
File No. S3-40  
Previous Newsletters GN21-5661

## IBM System/3 Model 15 Operator's Guide

© IBM Corp. 1974, 1976, 1977, 1978

This technical newsletter, a part of version 4, modification 0 of IBM System/3 Model 15D System Control Program (Program 5704-SC2) and also applicable to version 7, modification 0 of IBM System/3 Model 15A-B-C System Control Program (Program 5704-SC1), provides replacement pages for the subject publication. These replacement pages remain in effect for subsequent versions and modifications unless specifically altered. Pages to be inserted and/or removed are:

iii, iv	177, 178
25, 26	183, 184
73, 74	184.1, 184.2 (added to accommodate new and moved text)
89, 90	205, 206
137, 138	206.1, 206.2 (added to accommodate new and moved text)
147 through 158	215, 216
158.1, 158.2 (added to accommodate new and moved text)	237, 238
159 through 168	238.1, 238.2 (added to accommodate new and moved text)
168.1, 168.2 (added to accommodate new and moved text)	267 through 270
169, 170	270.1, 270.2 (added to accommodate new and moved text)
170.1, 170.2 (added to accommodate new and moved text)	271, 272
171 through 174	275 through 296
174.1, 174.2 (added to accommodate new and moved text)	

Changes to text and illustrations are indicated by a vertical line at the left of the change.

### Summary of Amendments

- Addition of the multiple job/step manipulation function (characters\*\* operand) to the CANCEL, CHANGE, HOLD, KEEP, and RELEASE commands
- Addition of the task history display function (task operand) to the DISPLAY command
- Addition of information in the system status and queue displays
- Addition of the HIPTY command
- Addition of the \$HACCP invocation function (CCP operand) and the SHA warning point function (tracks operand) to the HALT command

*Note:* Please file this cover letter at the back of the manual to provide a record of changes.

IBM Corporation, Publications, Department 245, Rochester, Minnesota 55901





## Contents

<b>YOUR ROLE AS AN OPERATOR</b>	vii	Power On and Ready Procedures	44
Job Documentation	vii	Last Card Procedure	44
Using the Machine Covers for Safety	vii	Card Jams	44
		Card Path	44
<b>PART 1. DEVICE OPERATION</b>	<b>1</b>	CHECK Light Indications	46
		Opening and Closing 2560 Covers	46
<b>CHAPTER 1. IBM 5415 PROCESSING UNIT CONTROLS AND INDICATORS</b>	<b>3</b>	Clearing a Card Jam	47
System Controls and Indicators	4	Changing the MFCM Print Ribbon	56
System Control Panel	5	Setting the MFCM Print Heads	57
Processing Unit Display Panel	6	Emptying the MFCM Chip Box	58
Emergency Power Off and Meter Panel	7	<b>CHAPTER 5. IBM 1442 CARD READ PUNCH</b>	<b>59</b>
Model 15B, 15C, or 15D Disk Panel	8	Controls and Indicators	60
Model 15A Disk Panel	8	Keys	60
BSCA (Binary Synchronous Communications Adapter) Panel	9	Status Lights	60
Lights	9	Usage Meter	60
Switches	10	Sense Lights	61
LCA (Local Communications Adapter) Panel	11	Power On and Ready Procedures	61
Lights	11	Last Card Procedures	61
Switches	12	Clearing a Card Jam	62
Customer Engineer Control Panel	12	Indications	62
CE Switches	12	Removing Cards From the Card Feed Path	62
Indicator Lights	13	Emptying the 1442 Chip Box	65
CE Keys	13	<b>CHAPTER 6. IBM 2501 CARD READER</b>	<b>67</b>
Selector Switches	13	Controls and Indicators	68
<b>CHAPTER 2. IBM 3277 DISPLAY STATION</b>	<b>15</b>	Indicator Lights	68
Controls and Indicators	16	Control Keys	69
Power Switch	16	Usage Meter	69
Keyboard	17	Power On and Ready Procedure	69
Indicators	24	Last Card Procedures	69
Display Operations	24	Clearing a Card Jam	70
Status Line	26	<b>CHAPTER 7. IBM 1403 PRINTER, MODELS 2 AND 5</b>	<b>71</b>
<b>CHAPTER 3. IBM 5424 MULTI-FUNCTION CARD UNIT</b>	<b>27</b>	Controls and Indicators	72
Controls and Indicators	28	Indicator Lights	72
Lights	28	Printing Control Keys	73
Keys	28	Carriage Control Keys	73
Usage Meter	29	Usage Meter	74
Customer Engineering Aids	29	Manual Controls	74
Clearing a Card Jam	29	Loading the Carriage Control Tape	79
Indications	29	Loading Forms	80
Removing Cards From the Card Feed Paths	29	Changing the Printer Ribbon	81
Changing the MFCU Print Ribbon	34	Changing the Print-Chain Cartridge	82
Removal	34	Controlling Print Quality	85
Installation	37	Print-Density and Forms-Thickness Adjustments	85
Emptying the MFCU Chip Box	39	Type-Face Cleaning	85
<b>CHAPTER 4. IBM 2560 MULTI-FUNCTION CARD MACHINE</b>	<b>41</b>	<b>CHAPTER 8. IBM 1403 PRINTER, MODEL N1</b>	<b>87</b>
Controls and Indicators	42	Controls and Indicators	88
Indicator Lights	42	Printer and Carriage Control Keys	88
Control Keys	43	Indicator Lights	89
Usage Meter	43	Usage Meter	90
		Manual Controls	90
		Loading the Carriage Control Tape	96
		Loading Forms	97
		Changing the Printer Ribbon	99
		Changing the Print-Train Cartridge	100
		Controlling Print Quality	102
		Print-Density and Forms-Thickness Adjustments	102
		Type-Face Cleaning	102

<b>CHAPTER 9. IBM 3284 PRINTER</b>	<b>103</b>
Controls	104
Switches	104
Paper Handling Controls	104
Power On Procedures	105
Loading Forms	106
Changing the Printer Ribbon	108
<b>CHAPTER 10. IBM 3410/3411 MAGNETIC TAPE SUBSYSTEM</b>	<b>111</b>
Controls and Indicators	112
Keys	112
Lights	112
Removing a Reel	113
Mounting a Reel	113
Replacing Tape Markers	113
Cleaning the Tape Head	114
Magnetic Tape Handling	115
<b>CHAPTER 11. IBM 5440 DISK CARTRIDGE AND IBM 5444 DISK STORAGE DRIVE</b>	<b>117</b>
Removing a 5440 Disk Cartridge	118
Mounting a 5440 Disk Cartridge	121
<b>CHAPTER 12. IBM 2316 DISK PACK AND IBM 5445 DISK STORAGE DRIVE</b>	<b>125</b>
Controls and Indicators	126
Removing a 2316 Disk Pack	127
Mounting a 2316 Disk Pack	129
<b>CHAPTER 13. IBM 3340 DIRECT ACCESS STORAGE FACILITY AND IBM 3344 DIRECT ACCESS STORAGE</b>	<b>131</b>
3340 Operator Panel	131
READY Indicator	131
START/STOP Switch	131
READ ONLY Indicator	131
COVER LOCKED Indicator	131
ATTENTION Key	131
3344 Operator Panel	131
READY Lamp	131
START/STOP Switch	131
ATTENTION Key	131
R/W or READ Switch	132
3340/3344 Power Panel	132
Machines Without String Switch Feature	132
POWER ON Switch	132
POWER OFF Switch	132
Data Module Loading	132
Data Module Unloading	133
Read Only Function	134
Enable Read Only Function	134
Disable Read Only Function	134
<b>PART 2. SYSTEM OPERATION</b>	<b>135</b>
<b>CHAPTER 14. PREPARING THE SYSTEM FOR PROGRAM OPERATION</b>	<b>137</b>
Clearing Cards from the Card Reader	138
Placing Forms in the Printer	138
Performing IPL	138
IPL from Disk (5444, 3340, or 3344)	138
IPL from the Card Reader	140
Initiating Program Execution	140
Clearing I/O Attention	140

<b>CHAPTER 15. USING OPERATOR CONTROL COMMANDS (OCC)</b>	<b>145</b>
Entering OCC	146
Operator Control Commands	147
CANCEL Command	148
CHANGE Card Type Command	152
CHANGE Copies Command	153
CHANGE Core Command	154
CHANGE Forms Type Command	155
CHANGE Partition Command	156
CHANGE Priority Command	157
DATE Command	158.1
DISPLAY Command	159
DUMP Command	171
HALT Command	173
HIPTY Command (5704-SC2 only)	174
HOLD Command	174.1
DELETE Command	176
KEEP Command (5704-SC2 only)	177
NOHALT Command	178
NODELETE Command	179
PTY Command	180
READER Command	182
RELEASE Command	183
RESTART Command	184.1
REUSE Command (5704-SC2 only)	186
ROLLOUT Command	187
SET Command	188
SIMULATE Command	189
START Command	190
STOP Command	194
TIME Command	196
TLOG Command	197
<b>CHAPTER 16. TERMINATING SYSTEM/PROGRAM OPERATION</b>	<b>199</b>
Responding to System Messages	200
Forced Responses	200
Scrolling System Messages	200
Using the Register Display Unit	200
Stopping a Job Before Completion	204
Entering a Cancel Option	204
Entering a CANCEL Command	205
Dumping Main Storage	205
EJ Completion Codes	207
Turning System Power Off	208
Restoring System Power	208
PWR CHK Light Only	208
PWR CHK and TH CHK Lights	208
No Lights	208
<b>CHAPTER 17. MULTIPROGRAMMING OPERATION</b>	<b>209</b>
Job Mode and Step Mode	210
Nonspoiled Operation	210
Using Job Mode	210
Using Step Mode	210
Spooled Operation	210
System Input Device Considerations	211
Multiprogramming Operating Procedures	211
Nonspoiled Operating Procedures	211
Spooled Operating Procedures	212
System Date Considerations	212

<b>PART 3. PROGRAM OPERATION</b>	<b>213</b>	<b>APPENDIX A. IMAGE STATEMENT</b>	<b>257</b>
<b>CHAPTER 18. OPERATION CONTROL LANGUAGE (OCL) OVERVIEW</b>	<b>215</b>	Description of the IMAGE Statement	257
<b>CHAPTER 19. OBJECT PROGRAM EXECUTION</b>	<b>229</b>	Print Chain Images	258
Executing an Inquiry Program	230	LC Print Chain	258
Executing an I-type Program That Uses the CRT/Keyboard for Input	230	HN Print Chain	259
Interrupting an Object Program (Rollout/Rollin) (5704-SC1 only)	230	AN Print Chain	259
Using Rollout with Spooling (5704-SC1 only)	232	PN Print Chain	259
RPG II Telecommunications Program	232	<b>APPENDIX B. PROBLEM DETERMINATION</b>	<b>261</b>
Nonswitched Networks	232	Performing Problem Determination	261
Switched Networks	233	Messages	261
Device Counter Logout Program	234	Program Checks	261
<b>CHAPTER 20. RUNNING SYSTEM SERVICE PROGRAMS AND UTILITY PROGRAMS</b>	<b>237</b>	Processor Checks	262
System Service Programs	238	<b>APPENDIX C. MODEL 10 PROGRAMMING SUPPORT</b>	<b>263</b>
Operating Procedures	239	Considerations	263
Disk Sort Program	243	Procedures	263
Tape Sort Program	243	<b>APPENDIX D. PROCEDURES FOR APPLYING PROGRAM TEMPORARY FIXES (PTFs)</b>	<b>265</b>
Disk Resident Card Utility Programs	244	Considerations	265
Sort/Collate Program	244	PTF List Program	265
List Program	247	<b>APPENDIX E. OPERATOR CONTROL COMMANDS (OCC) SUMMARY</b>	<b>267</b>
Reproduce/Interpret Program	248	<b>APPENDIX F. DUMP TO DISK PROGRAM</b>	<b>275</b>
Gangpunch Program	251	<b>APPENDIX G. PRINT \$SYSDDUMP FILE AND SYSTEM CONFIGURATION RECORD TO PRINTER (\$SCRNT)</b>	<b>277</b>
<b>CHAPTER 21. CHECKPOINT/RESTART OPERATION</b>	<b>253</b>	<b>BIBLIOGRAPHY</b>	<b>279</b>
Removing Cards Prior to Restarting a Checkpoint Program	254	System Control Programming	279
Restarting a Checkpoint Program	255	Communications	279
Intervening Programs	256	Program Products	279
		Other References	279
		<b>INDEX</b>	<b>281</b>

This page intentionally left blank.

As the operator of a System/3 Model 15, you can greatly affect the efficiency of your system. It is normally your responsibility to monitor the operation of the system by doing tasks such as:

- Initiating jobs to be run.
- Keeping I/O devices ready by supplying the resources they need (cards, forms, etc.) and correcting error conditions when they occur.
- Responding to messages as they are displayed by the system.
- Communicating with the system via the CRT/Keyboard.

This book is divided into three parts. Part 1 describes devices you have on the system and how to operate them. You should be familiar with Part 1 before going on to Parts 2 and 3. Part 2 describes how to operate the system composed of the devices described in Part 1. Part 3 gives general procedures for operating programs on the Model 15. Although partition 3 (P3) and 3344 Direct Access Storage are discussed throughout this manual, they are supported only by the System Control Program Number 5704-SC2.

The *IBM System/3 Model 15 Introduction*, GC21-5094, gives you a good overview of what the system is. Certain sections of this operator's guide assume that you have read the Introduction.

### JOB DOCUMENTATION

Information concerning the nature of each program and what is required of you as the operator to run that program must be supplied by the programmer. This information can be provided to you on a program run sheet.

A sample program run sheet is shown on the next two pages. The sample run sheet shows:

- The disk cartridge or tape reel to mount.
- The forms to use in the printer.
- The input device to use.
- The operation control language (OCL) statements used and any operator control commands (OCC) necessary.
- Any special procedures that are not normally performed but necessary with this program.
- Programmed halts to be used.

### USING THE MACHINE COVERS FOR SAFETY

Besides improving appearance, covers of IBM machines have been designed to protect you against possible injury during operation. While some hazards, such as moving mechanical parts, are obvious, others are not. Electrical potential and acoustical noise are in the latter category.

The frames of all IBM equipment have been made electrically safe by recommended grounding practices. Covers have been designed to reduce noise levels to a more comfortable range.

IBM maintains vigorous attention to safety on all its machines. However, the effectiveness of this effort is lessened when you fail to keep the covers closed while the system is running. Operation with the covers open causes needless exposure to unseen hazards. Because of this, IBM strongly recommends that all people working with the equipment follow the simple safety-first procedures of keeping all covers closed while the system is operating.

**IBM SYSTEM/3 MODEL 15  
SAMPLE PROGRAM RUN SHEET**

Program Name \_\_\_\_\_ Program Number \_\_\_\_\_

Programmer \_\_\_\_\_ Date \_\_\_\_\_ Application \_\_\_\_\_

**Job Description** Jobname: \_\_\_\_\_ Stepname: \_\_\_\_\_

---



---



---



---

**Job Preparation**

Card:	Hopper 1	Description and Source of Card Files
	Hopper 2	
Aux. Card:	Hopper 1	
Disk or Tape:	R1	Description of Disk or Tape Volumes and/or Files
	R2	
	F1	
	F2	
	D1	
	D2	
	D3 or D31	
	D32	
	D33	
	D34	
	D4 or D41	
	D42	
	D43	
	D44	
	T1	
	T2	
	T3	
	T4	
Printer:	Number	Description of Form
	Name	
Aux. Printer:	Number	

**Job Setup**

Devices Required By Program				Halt Default Severity				Spooling				
Card	Disk	Tape	Print	1	2	4	8	YES	NO			
MFCU 1	R1	T1	1403					RDR				
MFCU 2	R2	T2	3284					PRT				
MFCM 1	F1	T3						PCH				
MFCM 2	F2	T4										
1442	D1		Other	PF Keys								
2501	D2		BSCA 1	1	2	3	4	5	6	7	8	9
	D3		BSCA 2									
	D4		CRT/KBD									
			3741									
				Partition								
				1	2	3						

Max Program Size \_\_\_\_\_ Estimated Run Time \_\_\_\_\_







## **Part 1. Device Operation**



## Chapter 1. IBM 5415 Processing Unit Controls and Indicators

- System Controls and Indicators
- System Control Panel
- Processing Unit Display Panel
- Emergency Power Off and Meter Panel
- 5444 Disk Panel
- Binary Synchronous Communications Adapter Panel
- Local Communications Adapter Panel
- Customer Engineer Control Panel

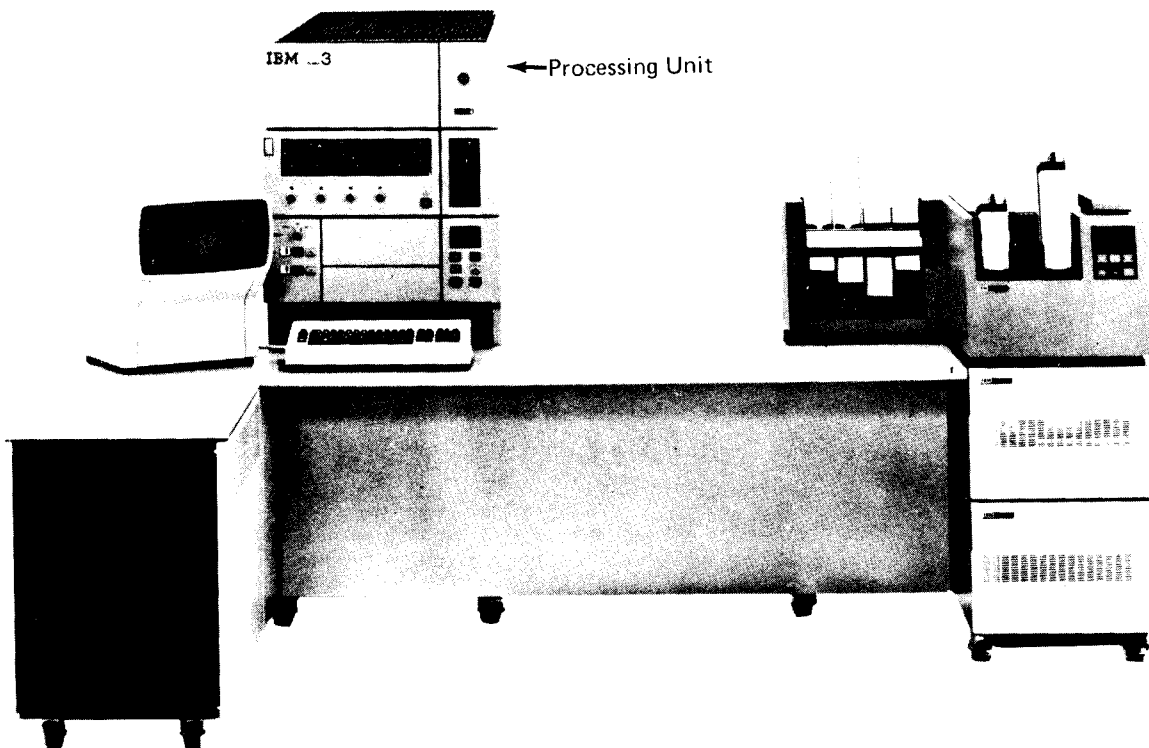

## SYSTEM CONTROLS AND INDICATORS

Each System/3 processing unit has lights, keys, and switches that are used for communication between you and the system. Lights indicate conditions existing in a device or in the system. Keys and switches are used to control operation of the system. Functions of the lights, keys, and switches on the processing unit are discussed in this chapter.

Controls and indicators for the processing unit are located on a large panel called the console (Figure 1). Although this panel is divided into several smaller panels, you will be concerned primarily with the system control panel and the disk panel. The processing unit display panel and customer engineer control panel are used primarily by the IBM Customer Engineer when he services the system.

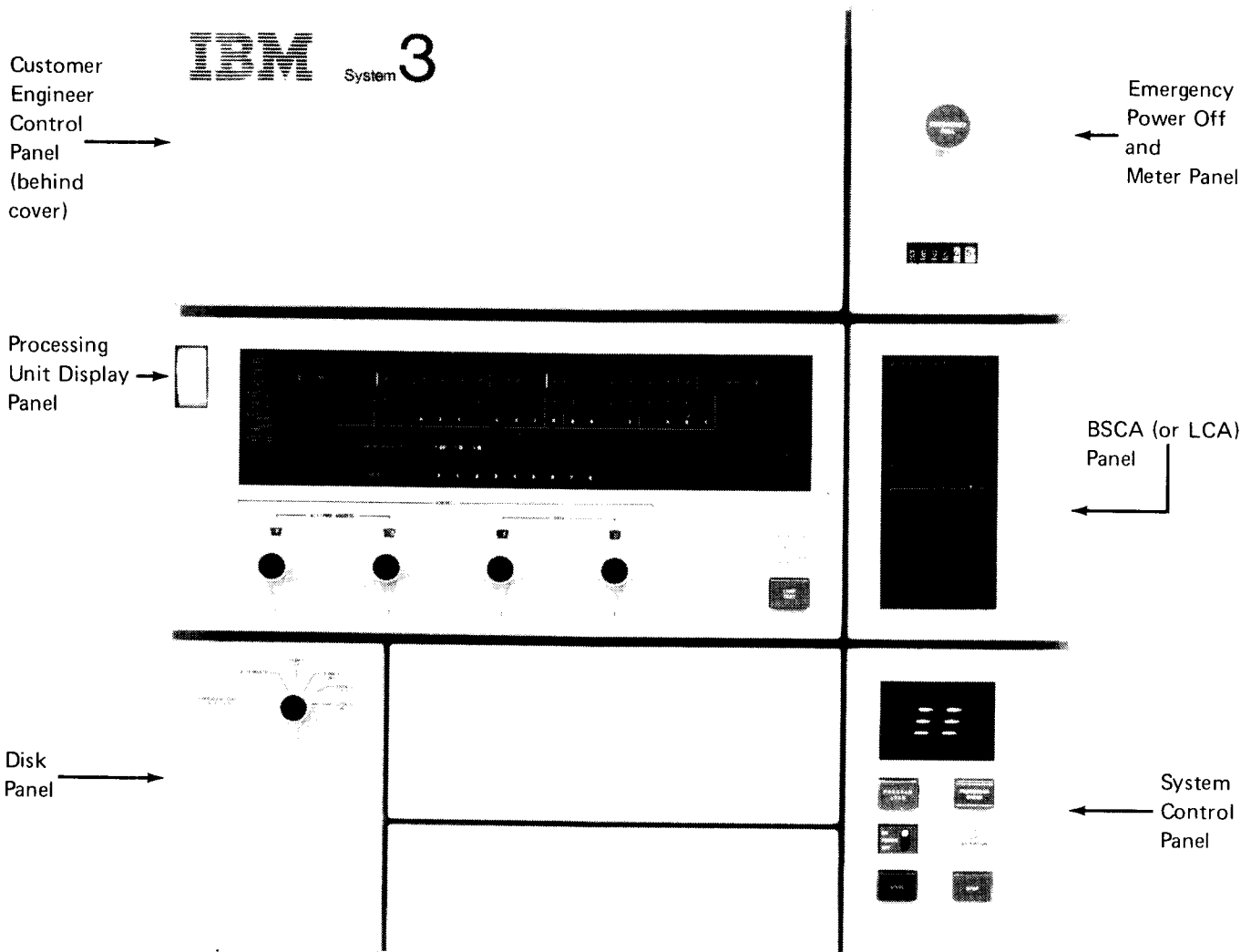

Figure 1. System Console Controls

## SYSTEM CONTROL PANEL

The controls and indicators on the system control panel (Figure 2) as well as those on the unit record device panels and the CRT/keyboard are the means by which you operate the system.

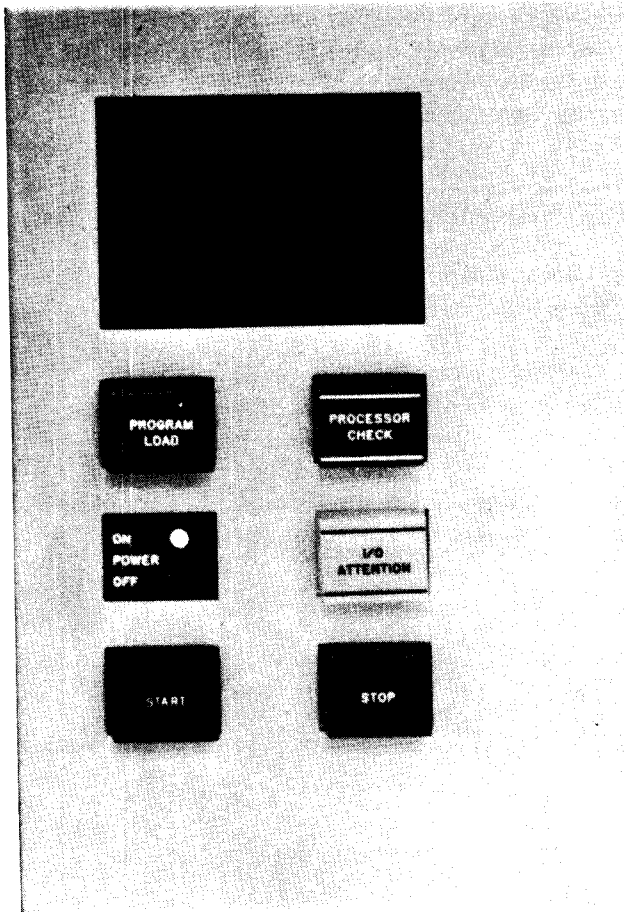

Figure 2. System Control Panel

**Message Display Unit:** This two-position display unit at the top of the system control panel displays messages when the CRT cannot be used. (The *IBM System/3 Model 15 System Messages*, GC21-5076, lists all Model 15 program messages.)

**PROGRAM LOAD Key:** This key is used when you perform the IPL (initial program load) process. This key is pressed after you have selected the device from which you will perform IPL. When you press this key, the IPL program begins and the programs necessary to run your jobs are loaded into storage.

**PROCESSOR CHECK Light:** This light comes on when certain errors occur in the processing unit. The error is displayed on the processing unit display panel. All processor checks are reset and PROCESSOR CHECK turns off when you perform the IPL process.

**POWER ON/OFF Switch:** This switch controls power to all units on the system. It is effective when (1) the EMERGENCY PULL switch is in its normal position, (2) the TH CHK (thermal check) indicator is not on, and (3) the PWR CHK (power check) indicator is not on. (The thermal and power check indicators are located on the processing unit display panel.)

When this switch is turned on, a system reset is performed so that no I/O operations are performed until explicitly directed.

**I/O ATTENTION Light:** This light can come on when the program requests any input/output device to do something and that device is not ready to do it. Usually this condition will cause an error message to be displayed.

Additional indicators on the device guide you to the exact cause of a not-ready condition. I/O ATTENTION goes off when the condition is corrected. Instructions for correcting the various causes of I/O ATTENTION are included in *Part 2. System Operation*.

**START Key:** When you press START, it allows the system to continue normal operation. Use START only (1) after a programmed halt has been displayed in the message display unit or (2) after you have pressed console STOP. Do not press START at any other time.

**STOP Key/Light:** When you press STOP, it causes the system to stop after completing the current operation. The STOP light comes on as soon as processing stops. You restart the system by pressing START.

## PROCESSING UNIT DISPLAY PANEL

The lights on this panel (Figure 3) indicate system status and are mainly for use by the IBM Customer Engineer.

**ADDRESS/DATA Switches:** These switches are used to specify an address or data. Switch settings can be tested by the program in operation, can be entered into storage, or can cause a storage location to be displayed by the register display unit.

**LAMP TEST Key:** When you press this key, all indicator lights on all units on the system come on.

**Register Display Unit:** This display unit consists of a row of 20 lights and an 8-position rotary switch. The lights display processing unit status and contents of main registers (intermediate storage areas). Any of eight different areas can be selected for display. Information on how to use the register display unit is contained in Part 2 of this manual.

**Cycle Control Display:** The 12 indicator lights labeled MACHINE CYCLE and the 10 indicator lights labeled CLOCK identify the processing cycle just completed.

**INT LEV Light:** This lamp turns on when an interrupt level is being serviced.

**TH CHK Light:** The TH CHK light turns on whenever the temperature of the processing unit or the printer or MFCM electronics exceed the limit set for normal operation. Power in the system shuts off and the TH CHK and PWR CHK (power check) lights turn on. For recovery procedures, see *Restoring System Power* in Part 2.

**PWR CHK Light:** The PWR CHK light turns on by:

1. Loss of voltage or overvoltage condition in the processing unit. (The TH CHK light is not on.)
2. Thermal conditions in the processing unit or the printer or MFCM electronics. (The TH CHK light is on.)

In both cases power in the system shuts off. For recovery procedures, see *Restoring System Power* in Part 2.

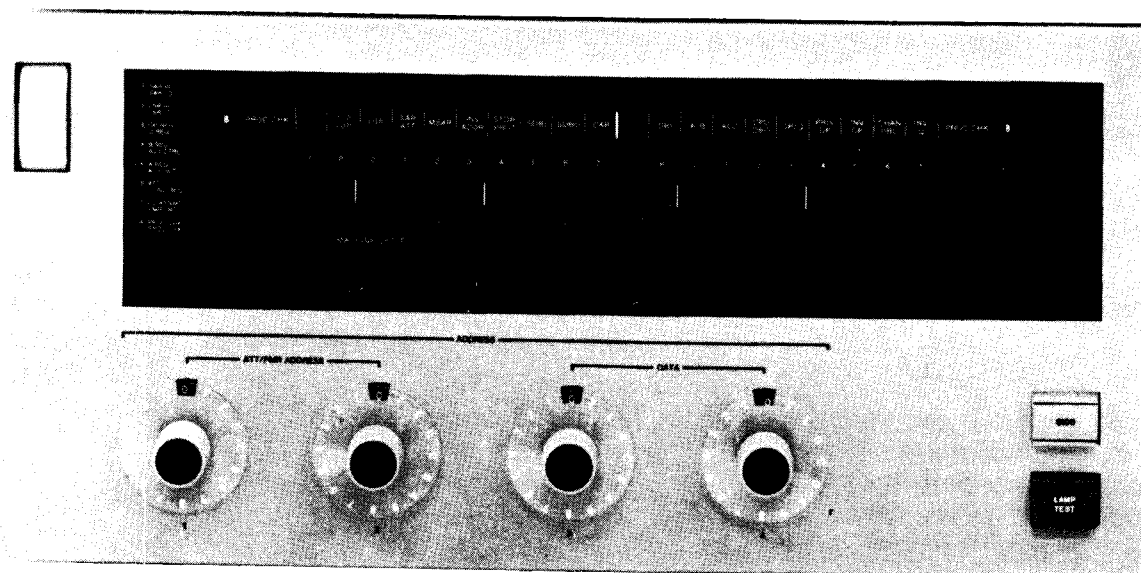

Figure 3. Processing Unit Display Panel

## EMERGENCY POWER OFF AND METER PANEL

*EMERGENCY PULL Switch:* This switch (Figure 4), as its name implies, should be used only under unusual circumstances. Once the EMERGENCY PULL switch is pulled, system power cannot be turned on until the IBM Customer Engineer has reset the switch. Information in storage is destroyed when this switch is used. Data on disks can also be destroyed by this operation.

*Usage Meter:* This meter (Figure 4) records the time used to process programs and data. The meter records all the time that the processing unit is in operation.

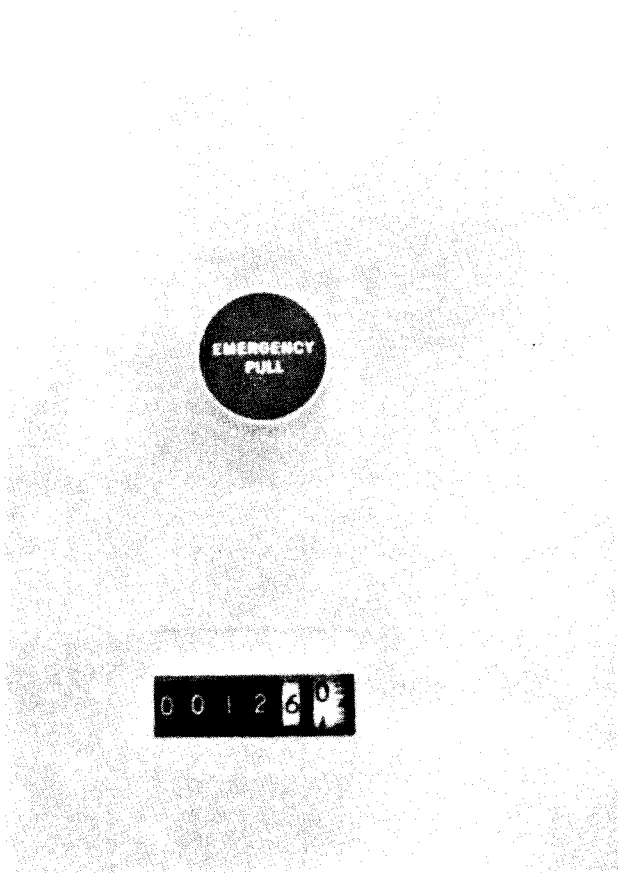

Figure 4. Emergency Power Off and Meter Panel

## MODEL 15B, 15C, OR 15D DISK PANEL

The Model 15B, 15C, or 15D disk panel (Figure 5) consists of a rotary switch (to indicate the initial program load device). Positions DISK 3 F1 and DISK 3 R1 are available on Model 15D having 3344 Direct Access Storage only.

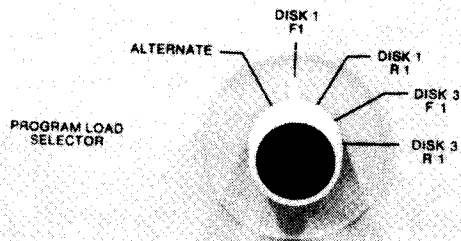

Figure 5 (Part 1 of 2). Disk Panel

**PROGRAM LOAD SELECTOR Switch, Model 15B, 15C, or 15D:** This rotary switch is used to select the unit from which you initiate IPL. DISK 1 F1, DISK 1 R1, DISK 3 F1, and DISK 3 R1 denote the simulation areas associated with each volume. The ALTERNATE position refers to the card unit on your system that can be used for IPL.

## MODEL 15A DISK PANEL

The Model 15A disk panel (Figure 5) consists of a rotary switch (to indicate the initial program load device) and controls and indicators that control the disk and indicate the status of the disk.

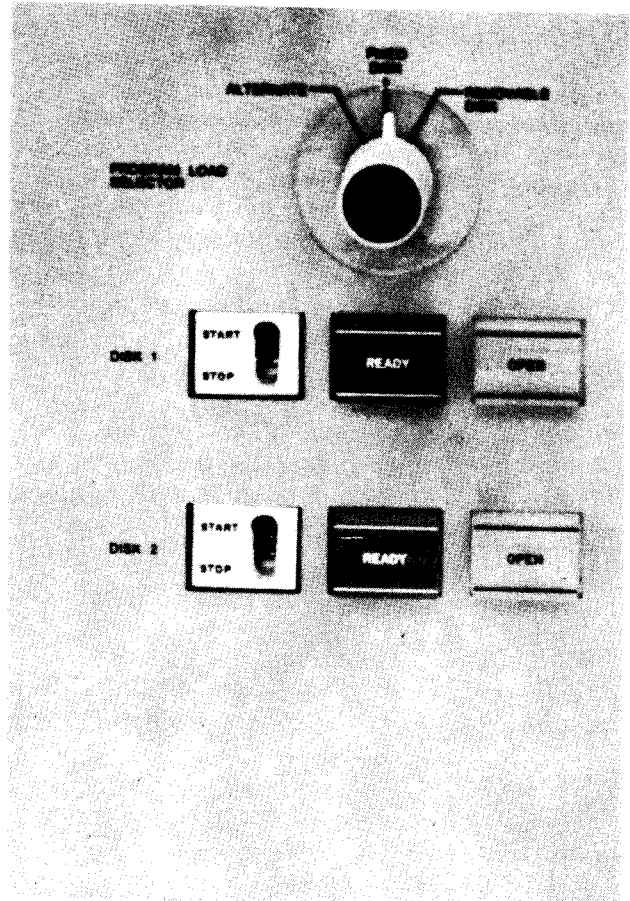

Figure 5 (Part 2 of 2). Disk Panel

**PROGRAM LOAD SELECTOR Switch, Model 15A:** This rotary switch is used to select the unit from which you initiate IPL. The FIXED DISK and REMOVABLE DISK positions refer to drive 1 only (top drawer). The ALTERNATE position refers to the card unit on your system that can be used for IPL.

**START/STOP Switches, Model 15A:** These switches (one for each drive) turn the disk drive power on or off when system power is on. With the switch at OFF and the OPEN light on, the drawer can be opened and the removable disk can be replaced.



**READY Lights, Model 15A:** These lights (one for each disk drive) are on when the drive is ready for use. If you try to use the drive before this light is on, the I/O ATTENTION light on the console turns on.

**OPEN Lights, Model 15A:** These lights (one for each disk drive) indicate that the associated disk drive drawer can be opened for changing the removable disk. This light is on when the START/STOP switch is placed at STOP and the disk has come to a stop.

### BSCA (BINARY SYNCHRONOUS COMMUNICATIONS ADAPTER) PANEL

The BSCA (binary synchronous communications adapter) panel (Figure 6) contains lights that indicate the status of telecommunication processing and a switch to control the rate of data transmission.

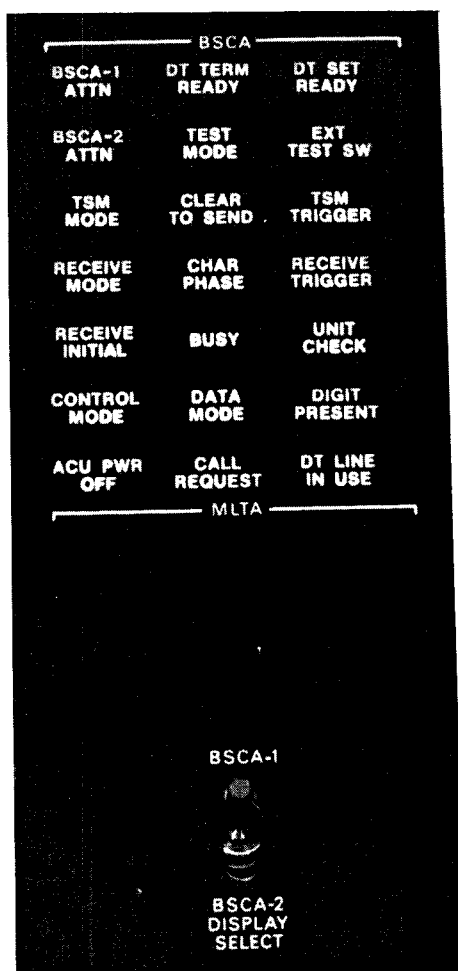

Figure 6. BSCA Panel

### Lights

The following text describes the lights you are concerned with when running BSCA programs:

**BSCA ATTN:** This light turns on when BSCA is addressed and one of the following conditions is present:

- A data set is not ready when a modem connection is used, or the attached device is not ready when a modem is not used (EIA local attachment).
- Auto call unit power is off.
- Data line is being used.
- BSCA is disabled.
- External test switch is in the TEST position and BSCA is not in the test mode.

The I/O ATTENTION light on the console is also on whenever the BSCA ATTN light is on.

**DT TERM READY:** This light turns on when BSCA is enabled and the data terminal ready line to the modem is on.

**DT SET READY:** This light turns on when the data set ready line from the data set is on and the data set is ready for use.

**TEST MODE:** This light turns on when a program places BSCA in the test mode of operation. The light is used only when diagnostic programs are run.

**EXT TEST SW:** For medium speed data sets, this light turns on when the switch on the cable is in the TEST position. For high-speed data sets or for 1200 BPS integrated modem feature, this light is on when the BSCA LOCAL TEST switch on the CE panel is in the ON position. This light is used only when diagnostic programs are run.

**TSM MODE:** This light turns on whenever data is being transmitted.

**CLEAR TO SEND:** This light turns on to indicate that the BSCA hardware may now transmit.

**TSM TRIGGER:** This light indicates the instantaneous value of the data being transmitted. The light is on when a space (a binary zero) is being transmitted on the communication line.

**RECEIVE MODE:** This light turns on when a receive operation is taking place.

**CHAR PHASE:** This light turns on when BSCA has established character synchronism with the transmitting station and is receiving data. The light is turned off when character synchronism is lost or when receive operations have ended.

**RECEIVE TRIGGER:** This light indicates the instantaneous value of the data being received. The light is on when a space (a binary zero) is being received on the communication line.

**RECEIVE INITIAL:** This light turns on at the initiation of a receive operation and turns off at the end of the initiation operation.

**BUSY:** This light turns on when BSCA is executing a receive initial, transmit and receive, autocal, receive only, or loop test (diagnostic mode) operation.

**UNIT CHECK:** This light turns on when the BSCA program should enter an error recovery procedure. When this indicator is on, the I/O CHECK light on the CE control panel is also on.

**CONTROL MODE:** This light is only on systems that have the multipoint tributary nonswitched network feature installed. The light turns on when an EOT sequence is detected in a transmit, receive, or receive initial monitor operation. It turns off when an SOH or STX is decoded.

**DATA MODE:** This light turns on during a transmit or receive operation when data is being checked for errors. It is turned off at the end of the transmit or receive operation.

**DIGIT PRESENT:** This light is only on systems that have the autocal feature installed. This light turns on when a digit is being presented by BSCA to the autocal unit.

**ACU PWR OFF:** This light turns on when the power for the autocal unit is off.

**CALL REQUEST:** This light turns on when an autocal operation is being performed.

**DT LINE IN USE:** This light turns on when autocal is being performed, or TALK has been pressed on the Data-Phone<sup>1</sup> while the phone is off the receiver.

### Switches

**RATE SELECT:** This switch is only on systems that have the rate select feature installed. The switch controls the rate at which data is transmitted and received. The switch must be set so the transmission rate of both terminals is identical.

**DISPLAY SELECT:** This switch is present only on systems that have two communication adapters (BSCA-1 and BSCA-2). This switch lets you display the indicators of either communication adapter but not both at the same time. This switch does not control the BSCA ATTN lights.

---

<sup>1</sup> Trademark of the American Telephone & Telegraph Co.

## LCA (LOCAL COMMUNICATIONS ADAPTER) PANEL

The LCA (local communications adapter) panel (Figure 7) contains the lights and a switch to indicate the status of location communication processing.

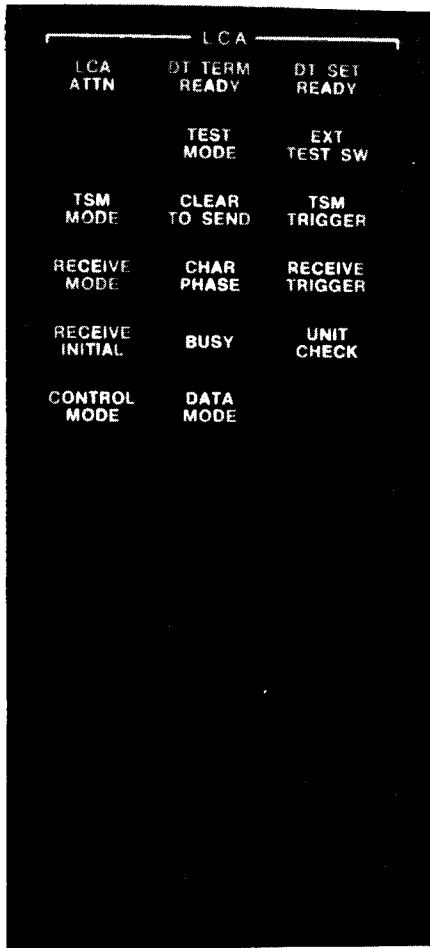

Figure 7. LCA Panel

### Lights

The following discussion describes the lights you are concerned with when running LCA programs.

**LCA ATTN:** This light turns on when LCA is addressed and one of the following conditions is present:

- The attached device is not ready.
- LCA is disabled.
- External test switch is in the TEST position and LCA is not in the test mode.

The I/O ATTENTION light on the console is also on whenever the LCA ATTN light is on.

**DT TERM READY:** This light turns on when LCA is enabled and the data terminal ready line from LCA is on.

**DT SET READY:** This light turns on when the data set ready line from the attached device is on and the attached device is ready.

**TEST MODE:** This light turns on when a program places LCA in the test mode of operation. The light is used only when diagnostic programs are run.

**EXT TEST SW:** This light turns on when the switch on the cable is in the TEST position. This light is used only when diagnostic programs are run.

**TSM MODE:** This light turns on whenever data is being transmitted.

**CLEAR TO SEND:** This light turns on to indicate that the LCA hardware may now transmit.

**TSM TRIGGER:** This light indicates the instantaneous value of the data being transmitted. The light is on when a space (a binary zero) is being transmitted on the communication line.

**RECEIVE MODE:** This light turns on when a receive operation is taking place.

**CHAR PHASE:** This light turns on when LCA has established character synchronism with the transmitting station and is receiving data. The light is turned off when character synchronism is lost or when receive operations have ended.

**RECEIVE TRIGGER:** This light indicates the instantaneous value of the data being received. The light is on when a space (a binary zero) is being received on the communication line.

**RECEIVE INITIAL:** This light turns on at the initiation of a receive operation and turns off at the end of the initiation operation.

**BUSY:** This light turns on when LCA is executing a receive initial, transmit and receive, autocall, receive only, or loop test (diagnostic mode) operation.

**UNIT CHECK:** This light turns on when the LCA program should enter an error recovery procedure. When this indicator is on, the I/O CHECK light on the CE panel is also on.

**DATA MODE:** This light turns on during a transmit or receive operation when data is being checked for errors. It is turned off at the end of the transmit or receive operation.

### Switches

**DISPLAY SELECT:** This switch is present only on systems that have two communication adapters (LCA and BSCA-2). This switch lets you display the indicators of either communication adapter but not both at the same time. This switch does not control the BSCA/LCA ATTN lights.

### CUSTOMER ENGINEER CONTROL PANEL

The switches, lights and dials on this panel (Figure 8) are used primarily by the IBM Customer Engineer to service the system.

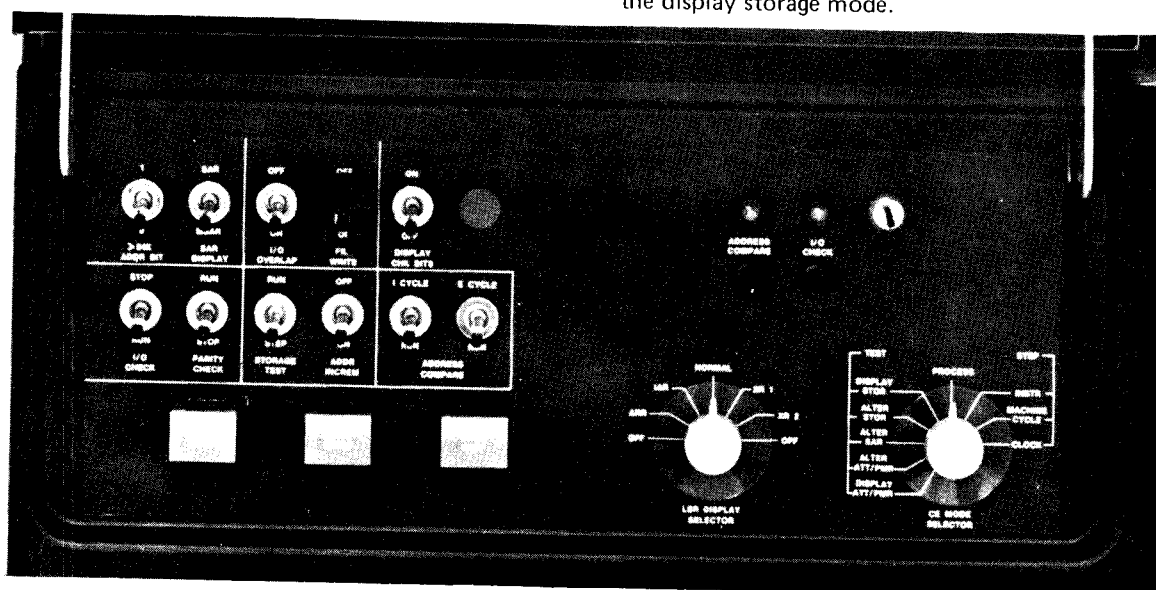

Figure 3. Customer Engineer Control Panel

### CE Switches

**> 64K ADDR BIT:** This switch is set at 1 when alter, display, or address compare operations are required on addresses above 64K.

**> 128K ADDR BIT:** This switch is set at 1 when alter, display, or address compare operations are required on addresses above 128K.

**SAR DISPLAY:** This switch controls the display in roller position 1. When the switch is in the SAR position, the display shows the translated, or logical, address. When the switch is in the MSAR position, the display shows the actual address used in main storage.

**I/O OVERLAP:** This switch enables the IBM Customer Engineer to control system input/output operations. When the switch is at the normal ON position, I/O operations are performed while the processing unit is doing other operations. When this switch is at OFF, each I/O operation must be completed before any other processing can be done.

**FILE WRITE:** While this switch is at ON, write operations can be performed on the 5444 Disk Storage Drives.

**DISPLAY CHK BITS:** When in the ON position, this switch causes the six memory check bits for the currently addressed half-word to be displayed in the Q register. This switch is for the IBM customer engineer's use when using the display storage mode.

**BSCA LOCAL TEST:** This switch is used for testing high-speed data sets or the 1200 BPS Integrated Modem Feature on BSCA-1 or BSCA-2. For normal operation, the switch is in the OFF position. The switch is used only in diagnostic mode to cause data to be looped from transmit to receive triggers of BSCA.

**I/O CHECK:** When this switch is set at STOP, the processing unit comes to an immediate stop whenever certain input or output errors occur. The system displays then show the status of the system at the time of the error. This switch is normally set at RUN, and the system does not stop when an I/O error occurs unless instructed to do so by the program in operation. The system displays then do not show the status of the system at the time of the error.

**PARITY CHECK:** This switch is normally set at STOP. When a parity error is detected, the processing unit stops and the error is displayed. When the switch is set at RUN, parity errors are detected and displayed in the register display unit (8 PROC CHK), but the system is not stopped.

**STORAGE TEST:** This switch allows the IBM Customer Engineer to alter or display storage in run or step mode.

**ADDR INCREM:** This switch is used by the IBM Customer Engineer to control a counter that increments the storage address register. This switch is effective only when the system is in the CE test modes of alter or display storage.

**ADDRESS COMPARE:** These switches enable the IBM Customer Engineer to stop the program during either I (instruction) or E (execution) cycles when the contents of the storage address register (SAR) match the setting of the ADDRESS/DATA switches. The ADDRESS COMPARE light also turns on when these addresses match. The CE MODE SELECTOR switch must be set at PROCESS and the register display unit must be set at 1 SAR HI for the ADDRESS COMPARE switch to be effective.

**CE Key:** This switch is operated by the IBM Customer Engineer to prevent recording time on the customer usage meter. It allows the CE meter to run when the system is being serviced.

## Indicator Lights

**ADDRESS COMPARE:** This light turns on when an address compare occurs (see *ADDRESS COMPARE Switches*).

**I/O CHECK:** This light turns on when certain errors occur in an input or output device. It is turned off when the SYSTEM RESET key or CHECK RESET key is pressed, or the input/output device error condition is corrected.

*Note:* The CHECK RESET key immediately resets all 3411 and 5445 functions and status indicators; therefore, do not press the CHECK RESET key while the 3411 or 5445 attachment is processing I/O instructions.

## CE Keys

**SYSTEM RESET:** When the SYSTEM RESET key is pressed, the system enters an idle state. All input/output and machine registers, controls, and indicators are reset. A program must be reloaded after a system reset. The CE MODE SELECTOR switch must be set at PROCESS for the SYSTEM RESET key to be effective.

**CHECK RESET:** When this key is pressed, all current error conditions in the processing unit and input/output devices are cleared. The system resumes normal operation when console START is pressed. The CHECK RESET key is also used to reset a power check.

**BSCA STEP or LCA STEP:** This key is used for BSCA or LCA testing. The key is effective only when BSCA or LCA is in the test mode and step mode.

## Selector Switches

**LSR DISPLAY SELECTOR:** This rotary switch detects the areas of internal storage to be displayed by the register display unit.

**CE MODE SELECTOR:** This rotary switch selects one of the three processing modes: process, step, or test. Process is the mode for normal system operation. In step mode, one of three settings can be used to control the way in which the program is executed. The test mode settings are used by the CE to display or alter storage.



- Controls and Indicators
- Display Operations

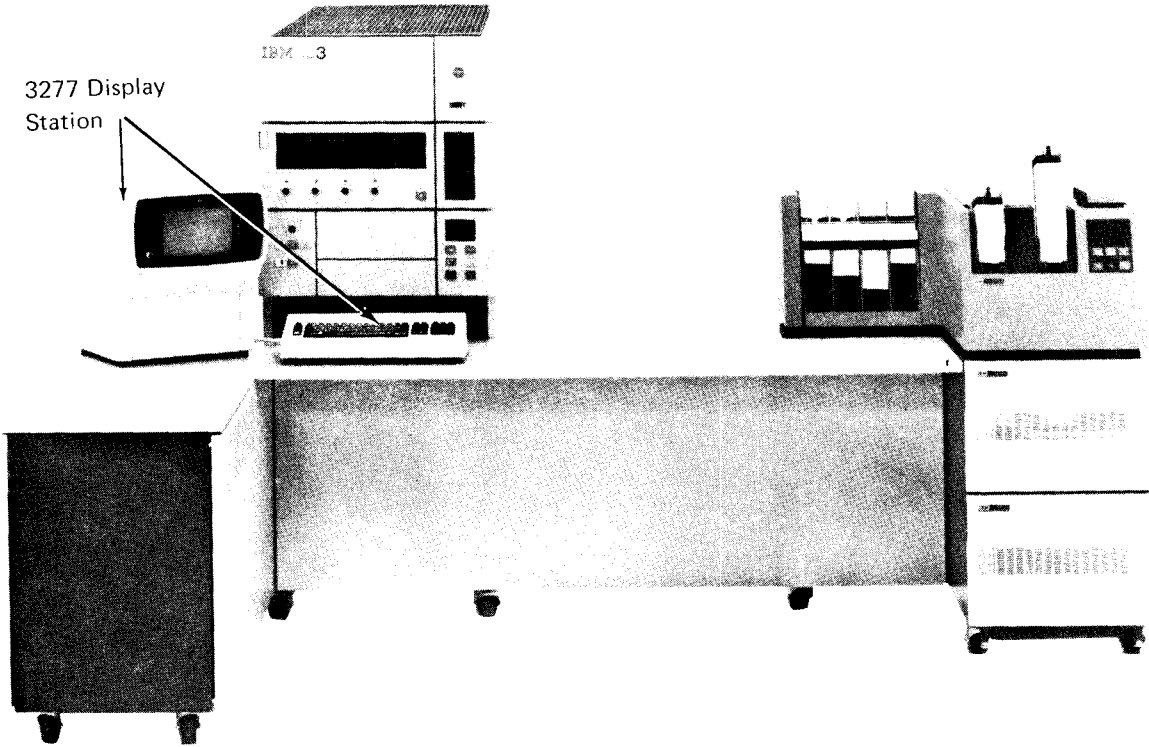

The IBM 3277 Display Station is your communication device for the Model 15. It consists of a cathode-ray tube (CRT) screen and a 78-key operator keyboard.

## CONTROLS AND INDICATORS

### Power Switch

The power switch is located at the lower left corner of the CRT screen (Figure 9). To turn on the power to the display station, pull out the switch labeled OFF-PUSH. A delay of a few seconds is built into the device to allow it to warm up. After this delay, a short horizontal bar (cursor) appears in the upper-left corner of the screen (Figure 9). To turn off the power to the display station, push the switch in.

The power switch is also used to control the clarity of the characters on the screen. The rear portion of the switch can be turned to adjust the contrast of the image on the screen. The front portion of the switch is used to adjust the brightness. The following diagram shows a side view of the power switch.

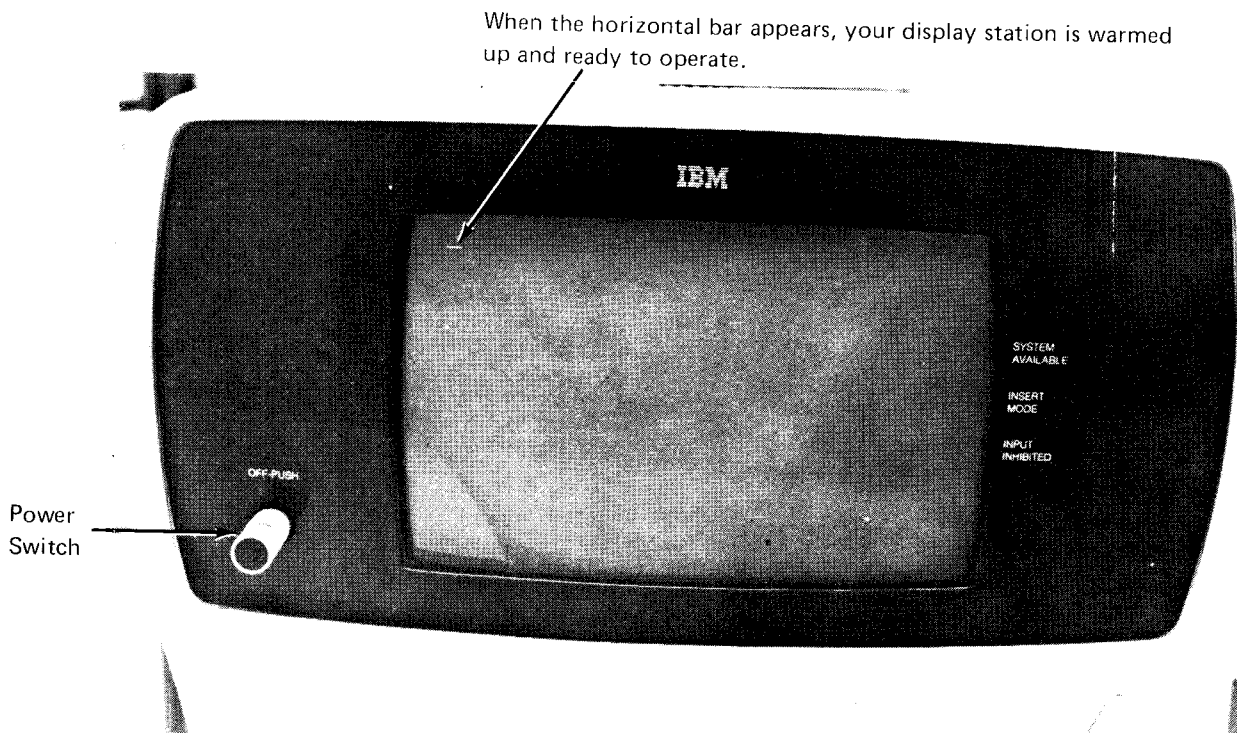
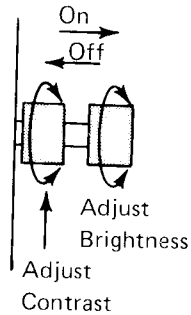

Figure 9. CRT Screen



## Keyboard

The keyboard for your 3277 Display Station contains 78 keys. (See Figure 10.) Some are used to enter data; the others are used to perform functions, either on the CRT screen or within the system. The data keys enter either numeric or alphabetic characters. All alphabetic characters are uppercase.

Some of the keys are typamatic; that is, the function of the key repeats as long as the key is held down.

Some function keys are used to position the cursor on the screen. These keys include a wrap-around facility. That is, if you are moving the cursor up, it moves off the top of the screen and appears in the same position on the bottom line. Similarly, when the cursor moves down off the screen, it appears in the same position in the top line. Wrap-around also occurs if the cursor moves off the side of the screen. It moves off the right side to the first position of the next lower line or off the left side to the last position of the previous line.

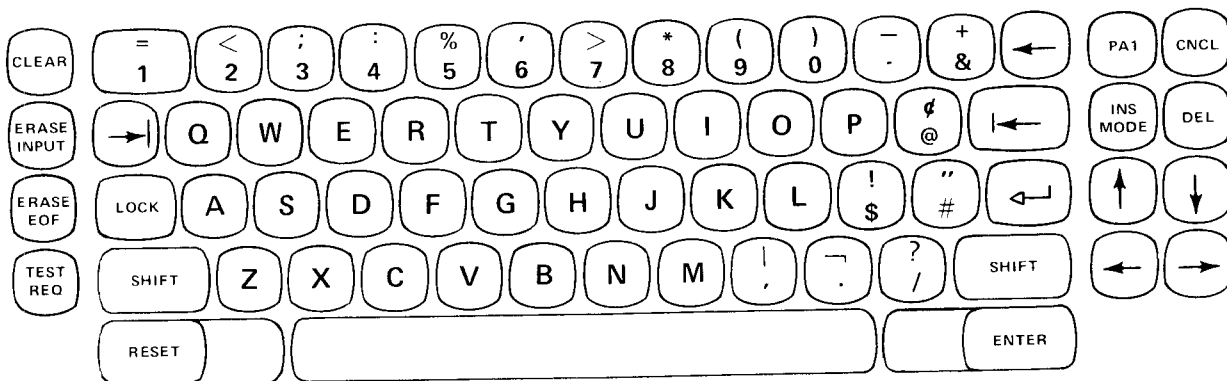

Figure 10. Operator Keyboard

### SHIFT/LOCK Keys

SHIFT and LOCK keys have the same function: both enable you to enter the character or symbol shown on the upper part of dual-character keys.

SHIFT places the keyboard in its upper position for as long as you hold it down; LOCK keeps the keyboard in its upper position until you press SHIFT.

SHIFT and LOCK have no effect on single-character keys.

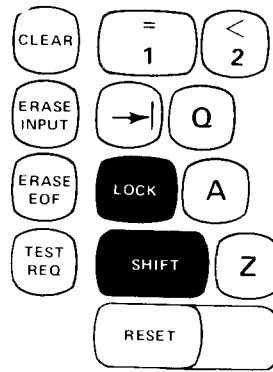

### Spacebar

When you press the spacebar, a blank is entered on the screen. Since a blank is considered to be a character on the 3277, the spacebar should not be used to position the cursor. The spacebar is typamatic.

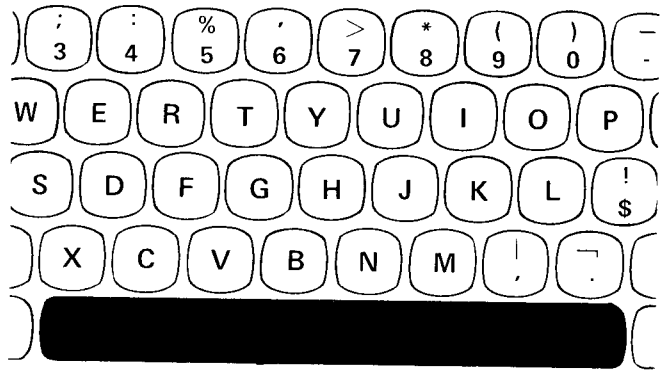

### Cursor Control Keys

The cursor control keys move the cursor (up, down, right, or left) to whichever position the next character is to be displayed in. These keys have no effect on the information on the screen nor do they cause any information to be entered.

All the cursor control keys except the back-tab key are typamatic and also provide the wrap-around function.

**New Line Key:** This key places the cursor in the first position of the next line in which you can enter a character.

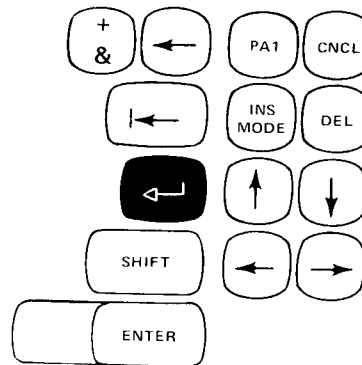

**Tab Key:** This key moves the cursor to the right to the first position of the next input field.

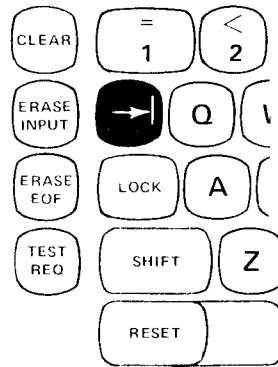

**Back Tab Key:** What this key does depends on where the cursor is when you press the key. If the cursor is in an unprotected data field but not in the first position of that field, the back tab key moves it to the first position of the field.

If the cursor is already in the first position of an unprotected field or if it is in a protected field, the back tab key moves the cursor to the first position of the last previous unprotected data field.

The back tab key is the only cursor control key that is not typamatic.

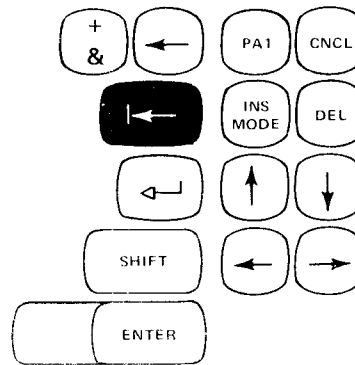

**Horizontal Positioning Key:** These keys move the cursor one position in the direction of the arrow.

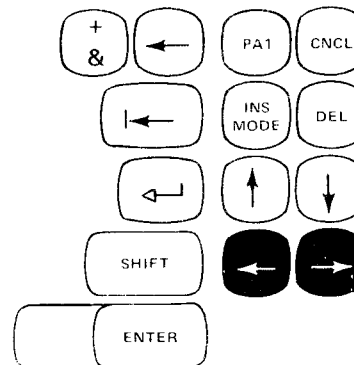

**Vertical Positioning Keys:** These keys move the cursor up or down one line in the direction of the arrow.

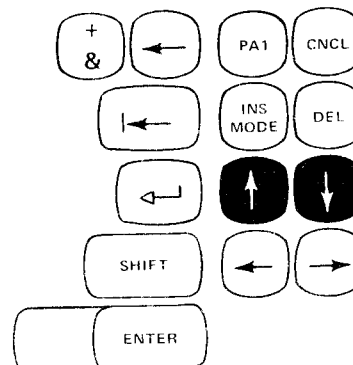

**Backspace Key:** This key moves the cursor one position to the left. The key is typamatic and operates exactly like the horizontal (left) positioning key.

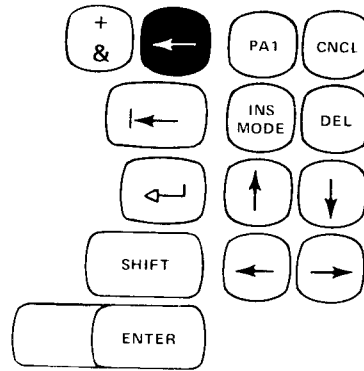

**CLEAR Key**

The CLEAR key removes all characters from the screen for as long as you hold it down. When you release the key, the original display appears again but any characters you had entered are removed.

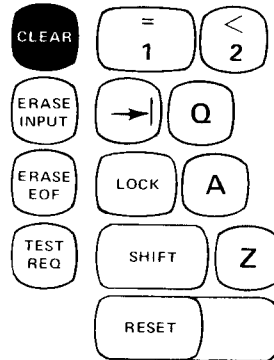

**ERASE INPUT Key**

This key clears characters from all unprotected areas on the screen and moves the cursor to the first unprotected character location.

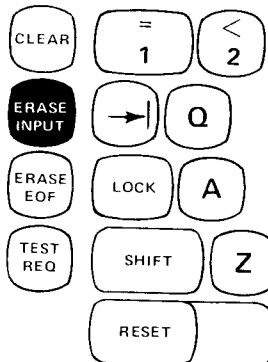

**ERASE EOF Key**

This key clears all remaining character locations in the field starting at the character location occupied by the cursor. The cursor does not move.

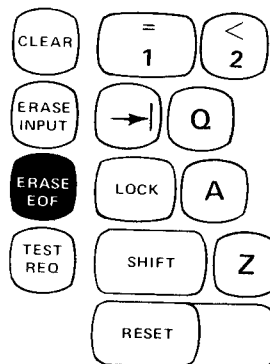

### TEST REQ Key

The TEST REQ key is reserved for the customer engineer's use.

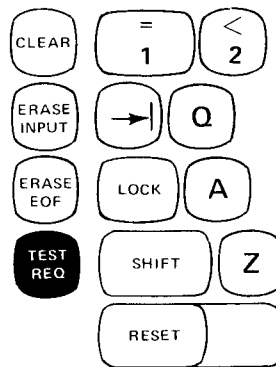

### RESET Key

This key turns off the INSERT MODE and INPUT INHIBITED indicators. If you press this key while data is being passed between the display station and the processing unit, these conditions will not be reset. In this case, press the RESET key again to reset the condition.

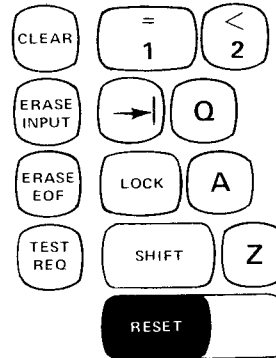

### PA1 Key

PA1 is a program access key. When you press the key, you tell the system that you are ready to enter data in response to a WAITING FOR REQUEST  $\left\{ \begin{matrix} P1 \\ P2 \\ P3 \end{matrix} \right\}$  prompt. The system responds by displaying ENTER DATA  $\left\{ \begin{matrix} P1 \\ P2 \\ P3 \end{matrix} \right\}$ , after changing the screen to the data management format (see *Display Operations* later in this chapter).

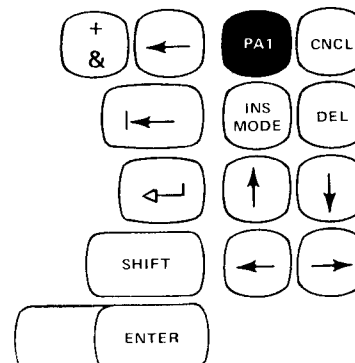

### INS MODE Key

This key allows you to insert one or more characters into a field without disturbing the rest of the field. When you press this key, the display station is put in the insert mode of operation and the INSERT MODE indicator turns on. All keyboard control keys operate normally in insert mode.

To insert characters in a field:

1. Move the cursor under the character that follows the characters you want to insert.
2. Press the INS MODE key.
3. Key in the character(s) you want to insert. Don't forget to also key in any blank characters that are necessary.
4. Press the RESET key to return the display station to normal operation.

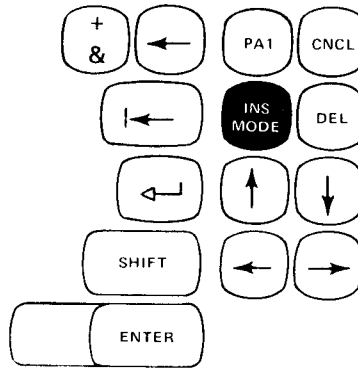

You will notice that as you enter each additional character, the remaining characters in the field are moved to the right one position. As each character is inserted, the last character in the field (if it is a zero) is lost. If you try to insert a character that would drop a non-zero character from the field, the INPUT INHIBITED indicator turns on and the keyboard is disabled.

### DEL Key

This key deletes the character in the position marked by the cursor if the cursor is in an unprotected data field. The character is erased without leaving a blank space; all characters to the right of the deletion in the same field and on the same line move one position to the left.

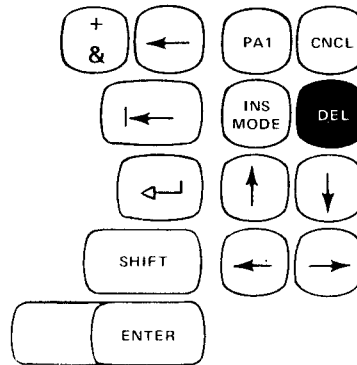

### ENTER Key

This key tells the program that you have finished entering your input and are ready to send it to the processing unit.

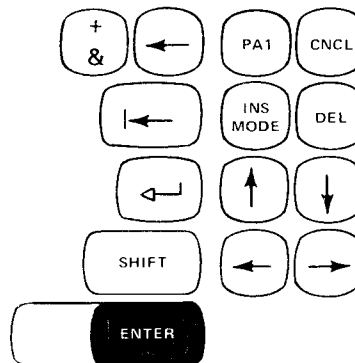

### CNCL Key

The CNCL key (or PA2 key on some systems) has no effect on the Model 15.

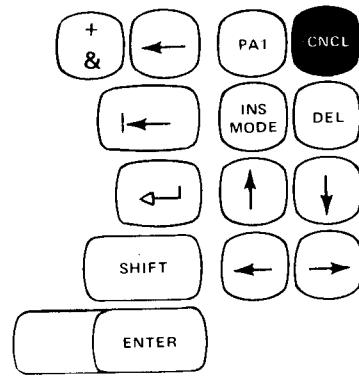

### PF1 - PF12 Keys

The PF1-PF12 keys provide a means of communication with the program via the display station.

- PF1-PF9 – The problem program determines the use of these keys.
- PF10 – This key tells the system that you are ready to enter OCC (operator control commands). If you have the System Control Program 5704-SC1, the system responds by formatting the screen in the system format and displays ENTER COMMAND. If you have the System Control Program 5704-SC2 and the system is in display format, you can enter OCC on the top line as shown in Figure 14. For more information on the system display format, see *Display Operations* later in this chapter. For more information on OCC, see *Chapter 15. Using Operator Control Commands (OCC)* in *Part 2. System Operation*.
- PF11 – This key has no effect in the Model 15.
- PF12 – This key is used when you want to respond to a message. The system responds by positioning the cursor in the response position for the latest message and displaying ENTER RESPONSE. For more information on the display format, see *Display Operations* later in this chapter. For more information on responding to messages, see *Chapter 16. Terminating System/Program Operation* in *Part 2. System Operation*.

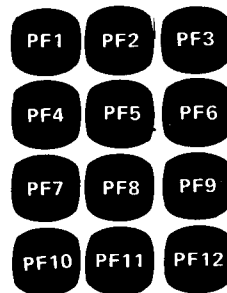

## Indicators

Your 3277 Display Station has three indicators at the right of the screen. When an indicator is on, a small square light appears on the screen adjacent to the indicator name (see Figure 11).

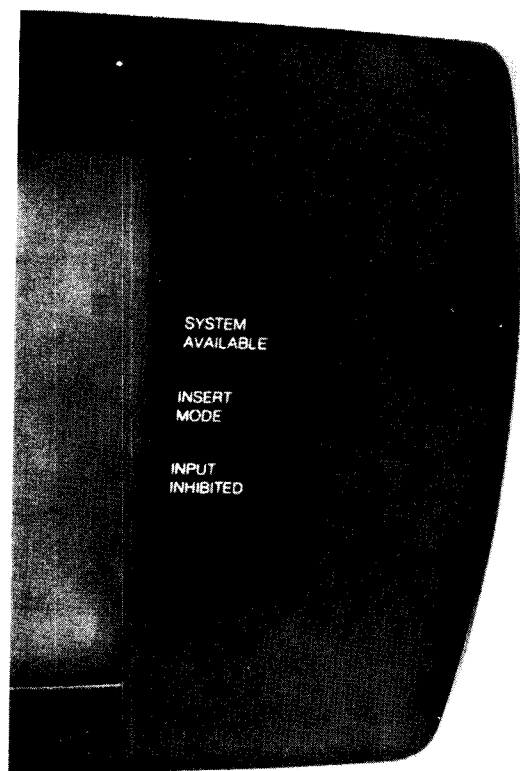

Figure 11. IBM 3277 Display Station Indicators

### *System Available*

The SYSTEM AVAILABLE light is on when your system is running and is available to receive information from the keyboard. When this indicator is off, you can press the keys on the keyboard but no data enters the system. However, the INPUT INHIBITED light will probably turn on.

### *Insert Mode*

The INSERT MODE light tells you that your display station is able to insert characters into fields that you have already keyed. New characters can be added at the position indicated by the cursor. When a new character is added, all characters to the right of it in the field are moved one position to the right. To turn off the INSERT MODE light and return to normal operation, press RESET.

### *Input Inhibited*

When the INPUT INHIBITED light is on, your keyboard is disabled and you cannot enter data. The keys work but no data enters the system. INPUT INHIBITED turns on when:

1. You have attempted to change data in a protected field.
2. Data is being passed between the display station and the processing unit (for example, after you press ENTER, PA1, or a program function (PF) key).

*Note:* INPUT INHIBITED turns off as soon as data has been passed to the system. Sometimes it is on such a short time that you don't even notice it.

To turn off the INPUT INHIBITED light and activate the display station, press RESET. If the cursor is at a protected field position, press RESET, then use the horizontal and vertical positioning keys to position the cursor in the appropriate field.

If pressing RESET does not turn off the INPUT INHIBITED light, there may be an attachment error. If a code is displayed in the message display unit, press the START key on the system control panel. If this action does not clear the condition, or if no code is displayed (indicating a possible program loop in the CPU), call your service representative for program support.

## DISPLAY OPERATIONS

The CRT screen contains 12 lines of 40 positions each. The 12 lines are used for different purposes depending on the format being used by the system at the time. There are three formats used by the system:

- System format (Figure 12)
- Data management format (Figure 13)
- Display format (Figure 14)

Data displayed on the screen and the responses expected from you determine which format is used. The last line, called the status line, is always the same regardless of the format.



In Figure 12, the first eight lines on the screen are used to display messages and your responses to them. For more information on responding to messages, see *Chapter 16. Terminating System/Program Operation* in *Part 2. System Operation*. The ninth through the eleventh lines are the area in which you enter OCC or system input data.

Figure 13 consists of seven lines of program input/output area (lines 1 through 7) and four lines of messages and responses (lines 8 through 11). The program input/output area is where you enter data in response to an ENTER DATA  $\begin{Bmatrix} P1 \\ P2 \\ P3 \end{Bmatrix}$  prompt and also the area where application programs can display data to you. Any system messages that occur while in this format are displayed in the messages/responses area.

Figure 14 is used when a display operation is in progress in response to a DISPLAY command. No system messages can occur during a display operation. The status line displays ENTER DISPLAY REQUEST when the CR1 screen is in the display format. During display operations, the first five positions of line 1 are used for controlling the display. To cancel the display, enter a C in the first position of line 1, then press ENTER. To print the contents of the display or put the display screen image in the system history area, enter one of the following, then press ENTER:

Entry	Result
PTSHA	Puts the display screen image in the system history area.
P3284	Prints the contents of the screen on the 3284 printer.
P1403	Prints the contents of the screen on the 1403 printer.

*Note:* Before entering P3284 or P1403, you must ensure that the printer is available. If the printer you specify is already in use, the operation it is performing is interrupted and the contents of the screen are immediately printed. This could cause undesirable results.

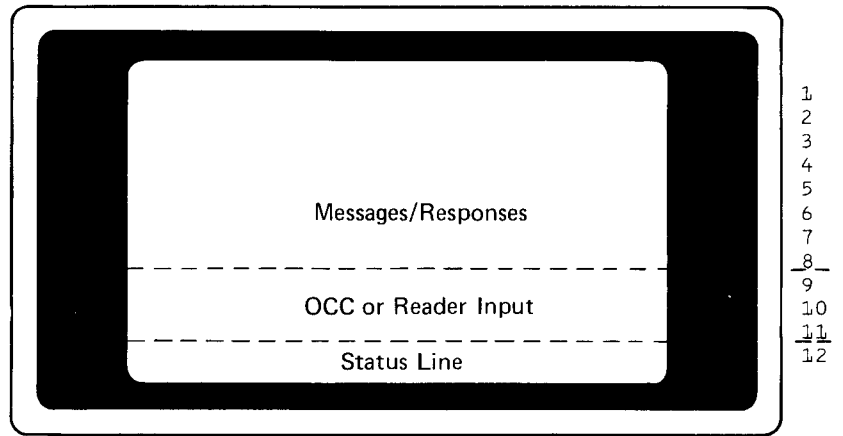

Figure 12. System Format

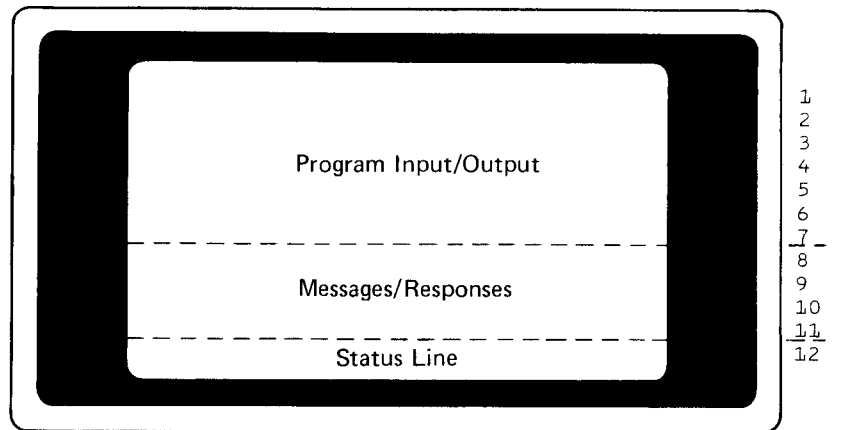

Figure 13. Data Management Format

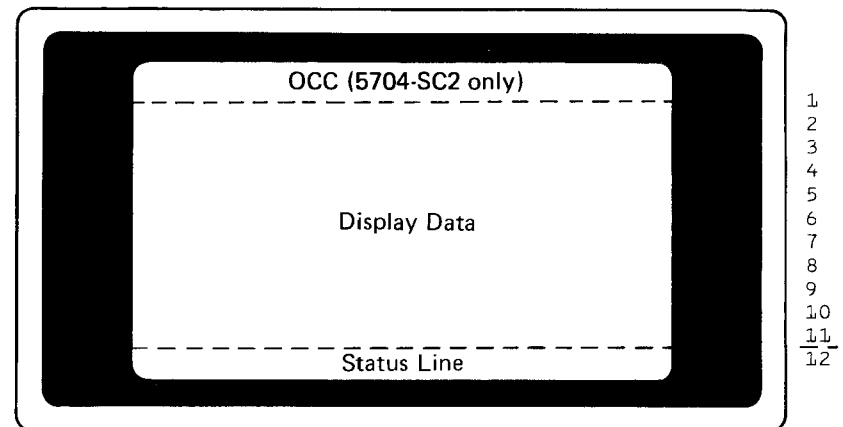

Figure 14. Display Format

## Status Line

This line is always displayed in the last CRT line. It tells you whether you are to enter data or respond to messages or if the system is ready for you to do either. It also shows how many messages have been displayed to which you have not responded. The format of the status line is:

```
XXXXXXXXXXXXXXXXXXXXXXXXX MSG NOT RSP nn
```

The area shown as Xs here is the portion of the line used for displaying prompts. A prompt is a message telling what information you should key in next. The following prompts might be displayed.

**READY:** No action is currently expected from you. There may be messages to which you have not responded, but the system will not expect a response to a message until you press PF12 to indicate that you are ready to respond.

**ENTER RESPONSE:** This prompt is displayed:

1. After you press PF12 to indicate you want to respond to a message.
2. When a response is required to a message in order for CRT operation to continue.

**Note:** Prompts that begin with ENTER stop the processing of all system messages until the operator responds by pressing the ENTER key. These prompts should be responded to as quickly as possible to ensure that processing continues. A \$CNFIG option (5704-SC2) allows messages to be displayed while in ENTER DATA or ENTER READER DATA mode. See the *IBM System/3 Model 15 System Control Programming Concepts and Reference Manual*, GC21-5162.

For more information on the use of ENTER RESPONSE, see the discussion of responding to system messages in *Chapter 16. Terminating System/Program Operation*.

**ENTER COMMAND:** This prompt is displayed after you have pressed PF10 and indicates the system is ready to accept OCC (operator control commands).

**WAITING FOR REQUEST**  $\left\{ \begin{matrix} P1 \\ P2 \\ P3 \end{matrix} \right\}$ : This prompt indicates that the system is ready to accept the data you want to enter. You press the PA1 key to indicate that you are ready to enter data. ENTER DATA  $\left\{ \begin{matrix} P1 \\ P2 \\ P3 \end{matrix} \right\}$  is then displayed in place of this prompt.

**ENTER DATA**  $\left\{ \begin{matrix} P1 \\ P2 \\ P3 \end{matrix} \right\}$ : This prompt is displayed when a program requests input or after you have pressed the PA1 key in response to the prompt WAITING FOR REQUEST.

**ENTER READER DATA**  $\left\{ \begin{matrix} P1 \\ P2 \\ P3 \end{matrix} \right\}$ : This prompt indicates the partition is using the display station as the reader device. You are expected to enter system input data for that partition.

**ENTER DISPLAY REQUEST:** Indicates that a display operation [see *DISPLAY Command* in *Chapter 15. Using Operator Control Commands (OCC)*] is in progress on the CRT screen because you entered a DISPLAY operator control command.

**MSG NOT RSP nn**

This message is always present in the status line. The nn is the number of messages that have been displayed for which no responses have been received.

## Chapter 3. IBM 5424 Multi-Function Card Unit

- Controls and Indicators
- Clearing a Card Jam
- Changing the MFCU Print Ribbon
- Emptying the MFCU Chip Box

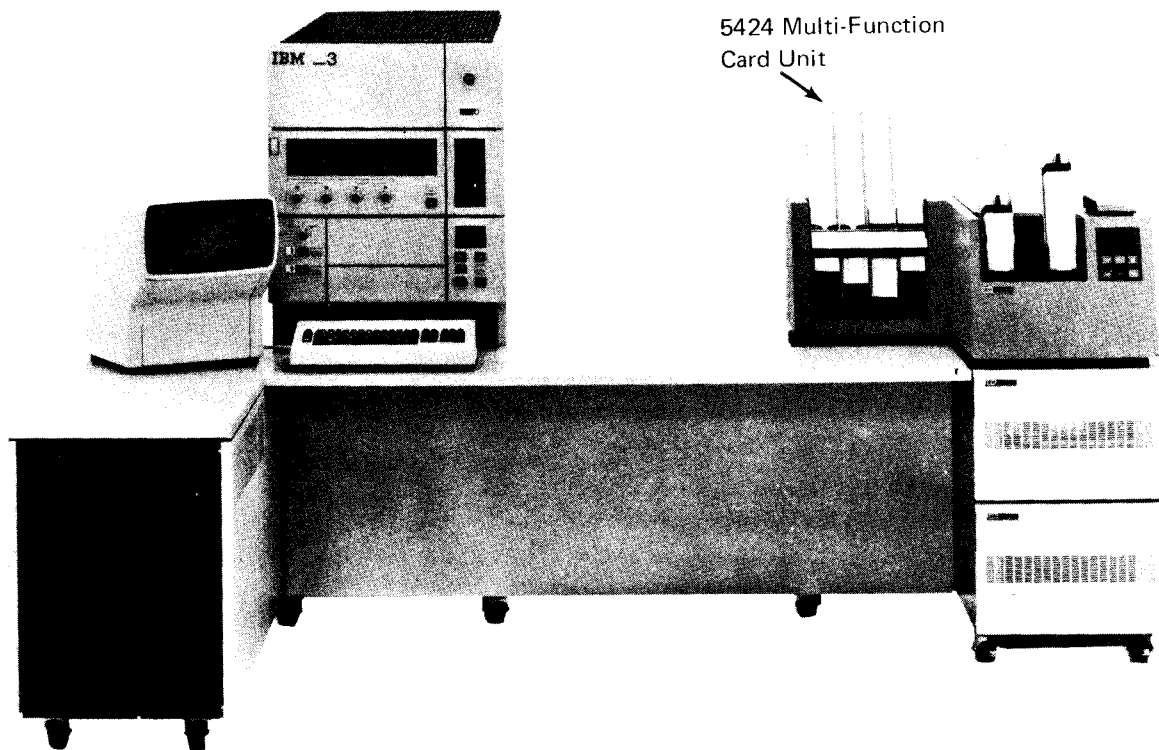

## CONTROLS AND INDICATORS

The lights and keys that you use to communicate with the MFCU are on the front of the MFCU.

### Lights

There are 30 lights on the top part of the MFCU operator's panel (Figure 15). Twenty of these are numbered and identify the position of cards within the MFCU when a feed check occurs (see *Clearing a Card Jam*). The other lights on the MFCU panel indicate the following:

**SEC:** The last card was fed from the secondary hopper.

**PRI:** The last card was fed from the primary hopper.

**RD:** There was a read check on the last card read. The SEC or PRI light indicates which hopper the card came from.

**HPR:** A card did not feed from the selected hopper. The SEC or PRI light indicates which hopper failed to feed a card.

**NPRO:** The card paths are not clear. This light also comes on when the system is turned on. To turn the light off, remove all cards from the hoppers and press the NPRO key twice after turning on the system. The hoppers must be empty for the NPRO key to be effective.

**STKR:** One of the four stackers is full. You can turn this light off by removing the cards from the stacker and pressing START or NPRO.

**CHIP:** The chip box is either full or out of the machine. To turn the light off, correct the condition and press START or NPRO.

**CVR:** The top covers are open or not securely latched. To turn the light off, close the covers and press START or NPRO.

**SECONDARY READY:** The secondary feed path is ready for operation.

**PRIMARY READY:** The primary feed path is ready for operation.

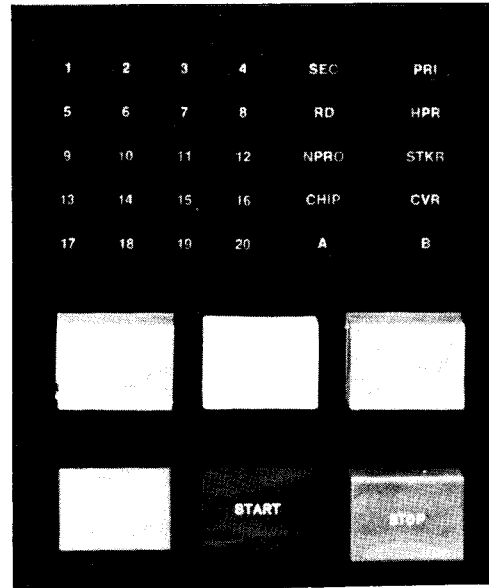

Figure 15. MFCU Controls and Indicators

### Keys

**NPRO (Nonprocess Runout):** Press this key to clear cards from the MFCU. Make sure the card hoppers are empty. Press the key twice to clear both the primary and secondary card paths. The primary feed path is cleared first. Both feed paths empty into stacker 1.

**START:** Press this key to place the MFCU in a ready condition. One or both card feeds are readied, depending on whether cards are in the hoppers and the card paths are clear. Use of the START key does not cause cards to feed from the hoppers.

**STOP:** Press this key to indicate to the system that the MFCU should stop after it completes the current operation. The READY lights turn off.

## Usage Meter

The 5424 usage meter records time from the time the first 5424 command is received until the time that runout is complete. Runout is accomplished by pressing the NPRO key.

## Customer Engineering Aids

If you press the LAMP TEST key on the processing unit display panel, you will see two additional indicators on the MFCU panel. They are labeled A and B. These lamps are CE diagnostic aids and are not lit during normal system operations.

## CLEARING A CARD JAM

The following procedure tells you how to remove cards from the MFCU card paths.

The program recovery procedure — what to do with the cards to continue program operations — are listed under the F0 and F1 messages in the *IBM System/3 Model 15 System Messages*, GC21-5076.

## Indications

A misfeed or card jam in the MFCU is indicated by any or all of the following:

- F0 or F1 message on the CRT screen.
- MFCU ready lights are off.
- A number (1 to 20) is lit on the MFCU operator's panel.
- NPRO light is on.

The numbers on the MFCU operator's panel indicate where in the card paths the trouble occurred. When a misfeed or jam occurs, write the number down in your console log book. If the same number occurs repeatedly, the MFCU needs service.

When the card paths are cleared, press NPRO twice to turn off the error indicator on the MFCU operator's panel.

## Removing Cards From the Card Feed Paths

The MFCU card paths are shown in Figure 16. The numbers on the figure refer to the step numbers that show how to remove a card from a particular place in the card path.

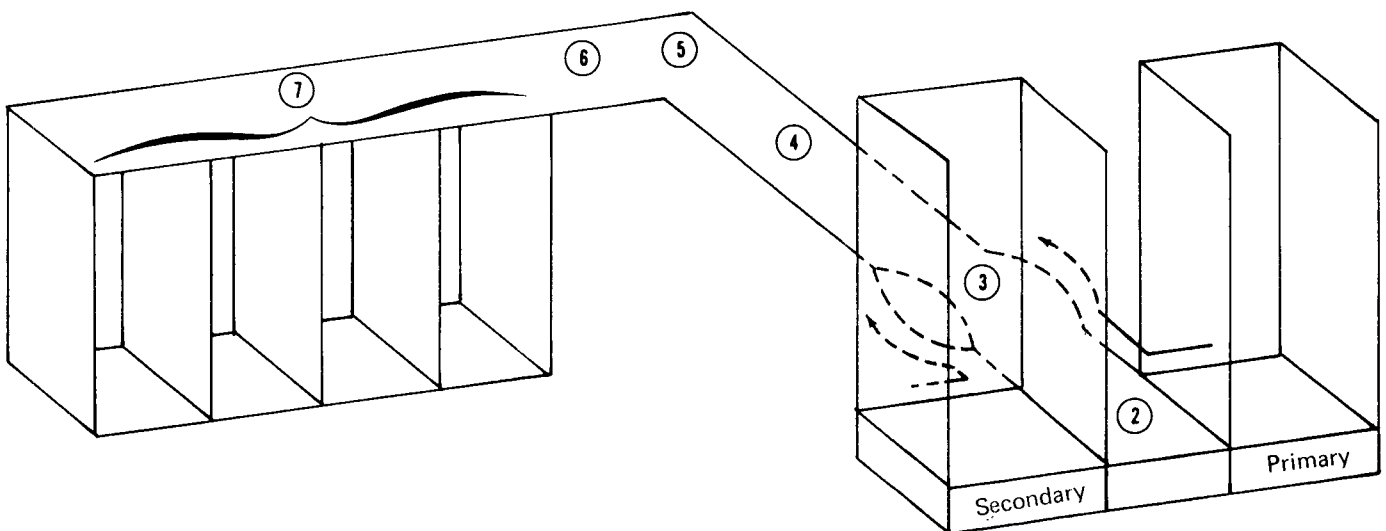
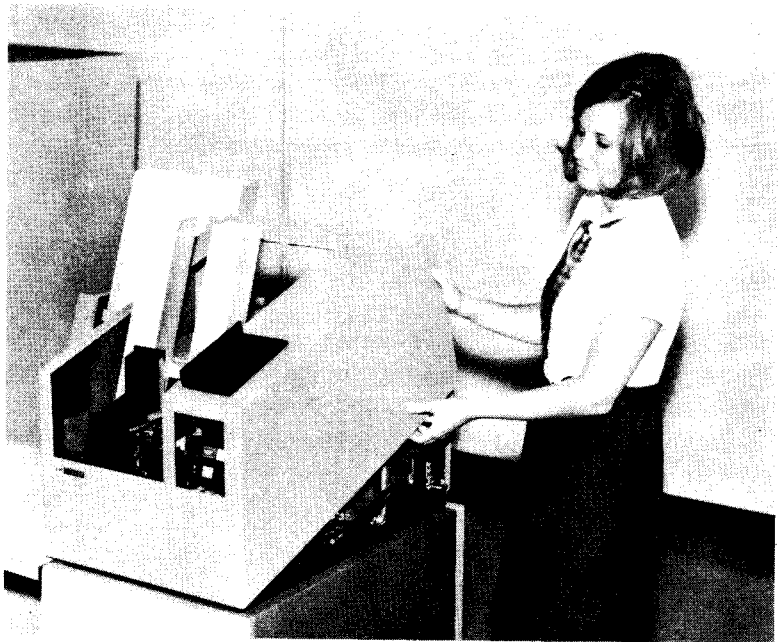

Figure 16. MFCU Card Paths

- 1 To open the MFCU top covers, lift latch to release cover. Pivot outer and inner top covers toward front of machine.



- 2 To remove a card from the hopper station, press down on latch and raise cover. Close cover when station is cleared.

If a card will not come out, free it by turning the feed drive wheel (see step 4).

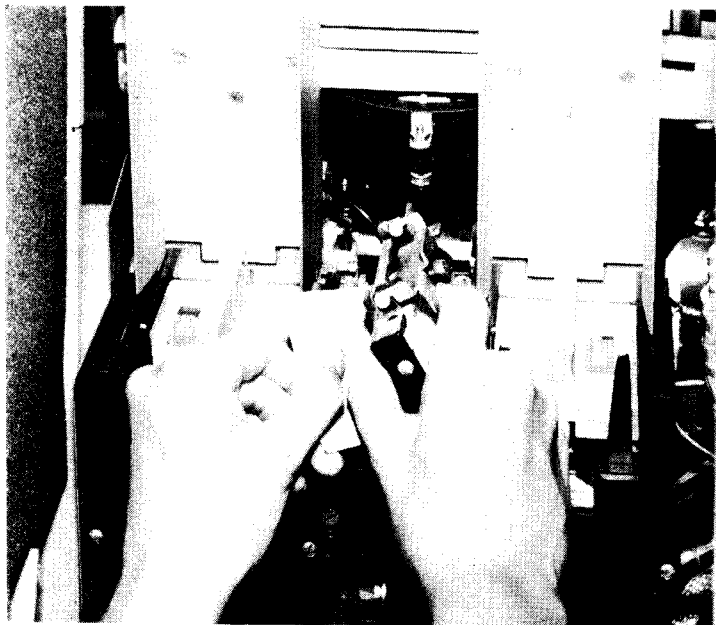

- 3 To remove a card from a wait station, open the spring-loaded cover and remove the card.

Primary  
Wait

Secondary  
Wait

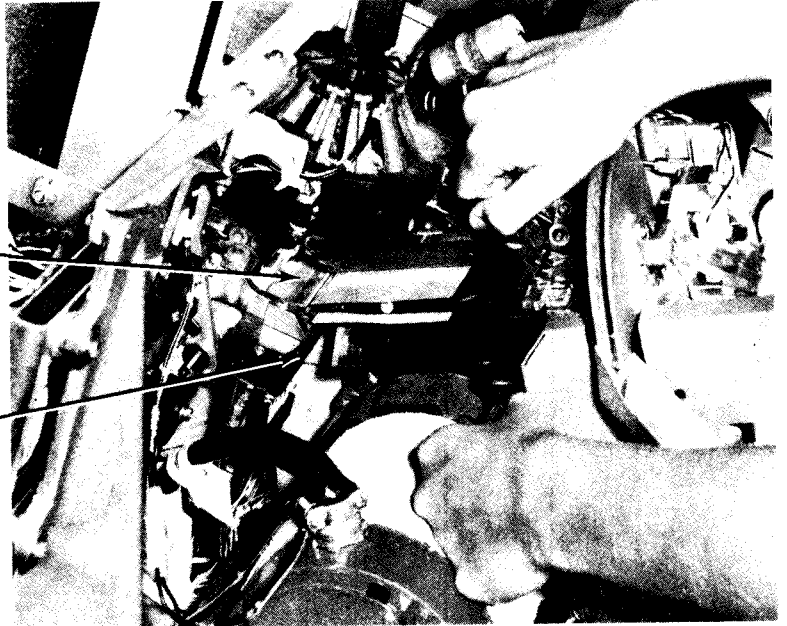

- 4 To remove a card from the punch unit, turn the feed drive wheel clockwise to advance the card.

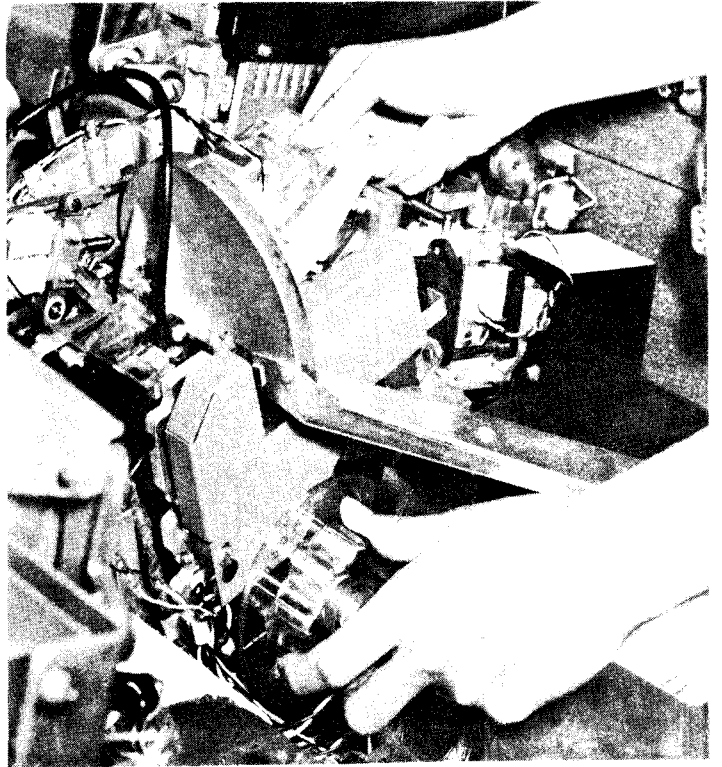

- 5 To remove a card from the corner station, pull back on the latch to open the cover. Close the cover when the station is cleared.

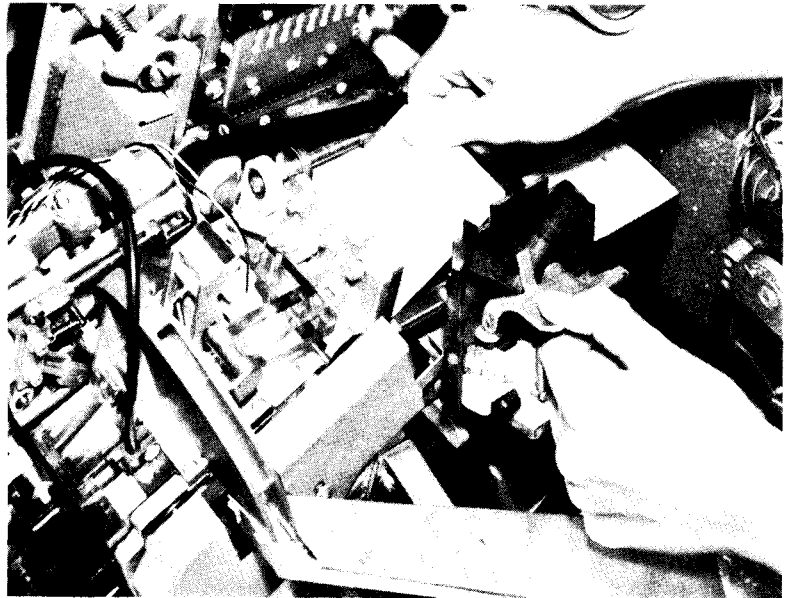

- 6 To remove a card from the print unit, turn the shaft counterclockwise to unlock the print unit. Tip the unit toward the front of the MFCU. Lock the print unit when the station is cleared.

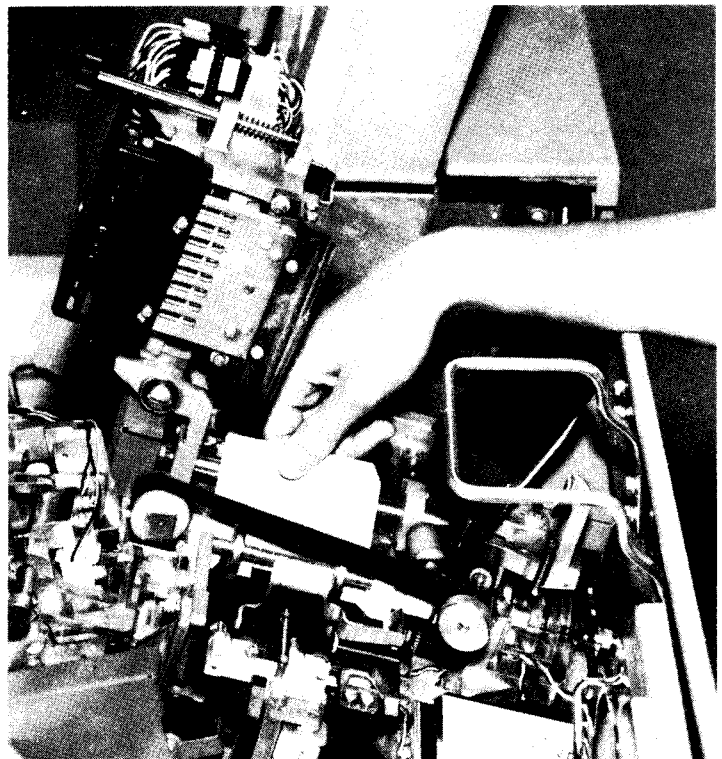



- 7 To clear a stacker jam, raise the spring-loaded cover over the stackers and remove the jammed cards.

If a card will not come out, open the top covers and free it by turning the feed wheel drive (see step 4).

Never remove cards from the stackers while the MFCU is running.

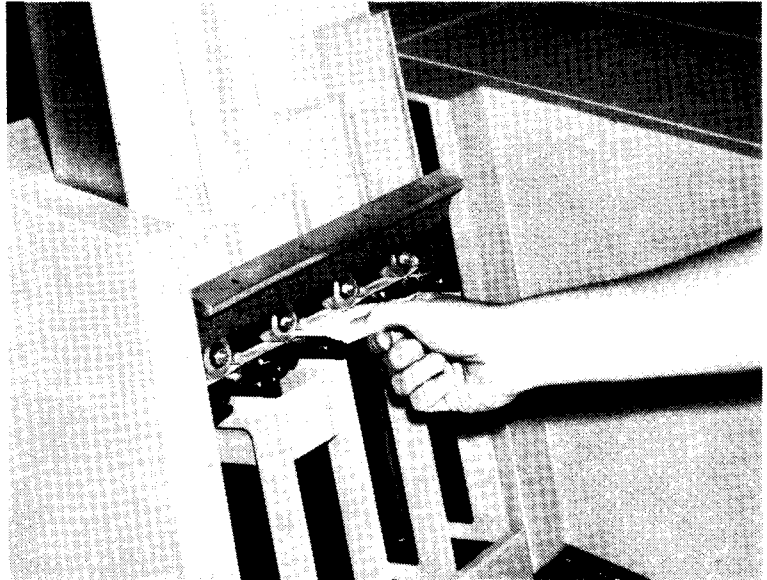

## CHANGING THE MFCU PRINT RIBBON

### Removal

- 1 Open the MFCU top covers. Lift the latch to release the cover. Pivot the outer and inner top covers toward the front of the machine.

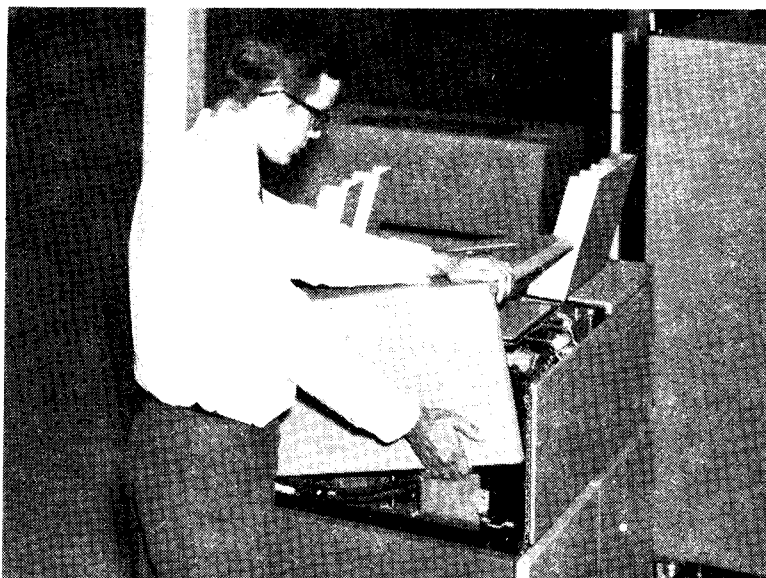

- 2 Raise the print unit. Turn the shaft counterclockwise to unlock. Tip the unit toward the front of the MFCU.

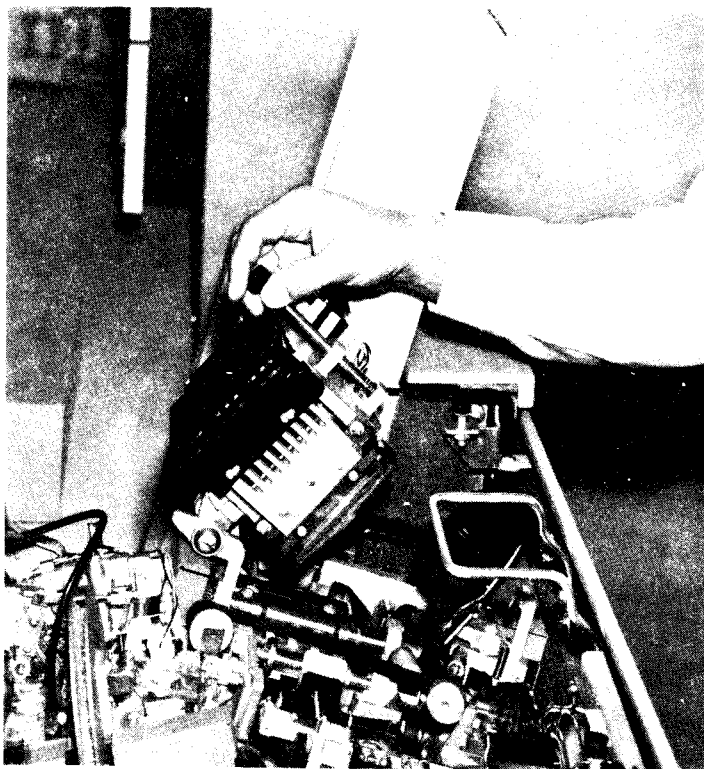

- 3 Slide the ribbon out of the ribbon drive. Pull the ribbon back toward the ribbon drive to get slack.

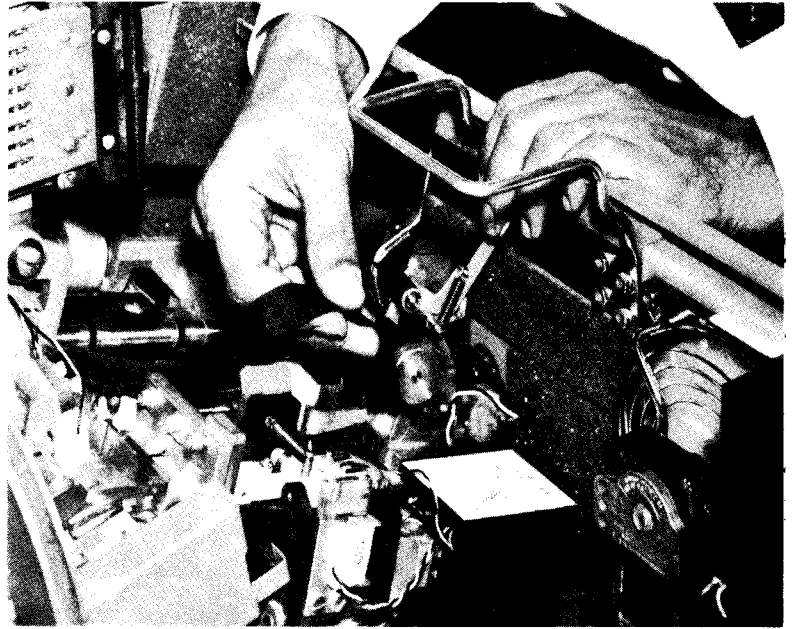

Split Shaft

- 4 Squeeze the split shaft holding the ribbon cartridge and pull the cartridge off the shaft.

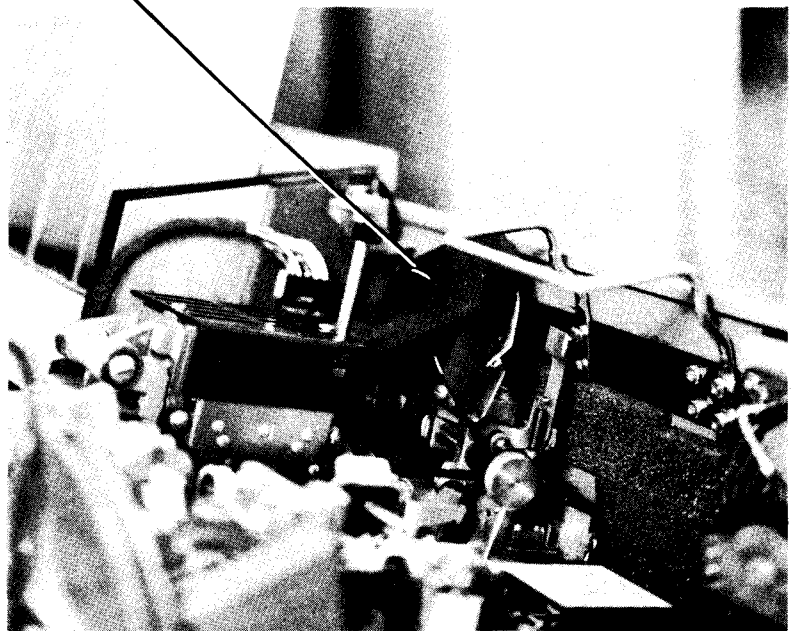

- 5 Slip the ribbon out from under the guide plate and the front and rear rollers and remove the ribbon cartridge.

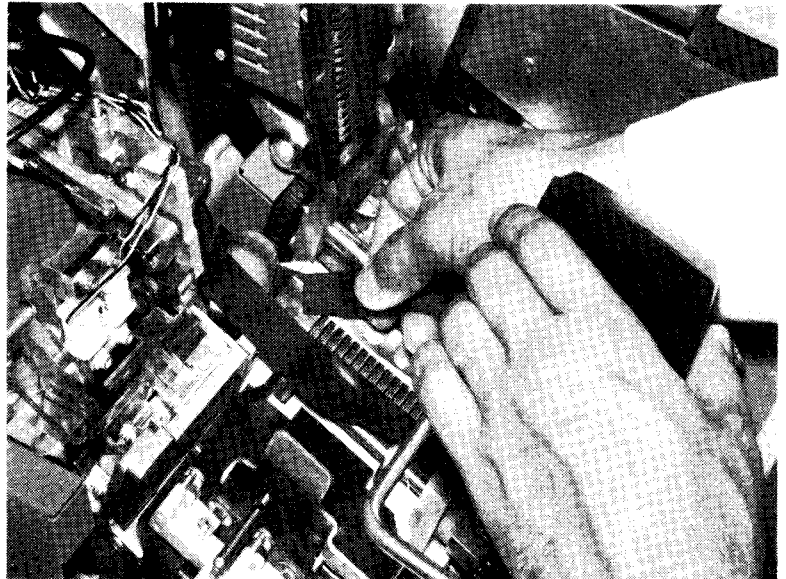

## Installation

- 1 Snap a new ribbon cartridge in place. The ribbon feeds down from the back of the cartridge.

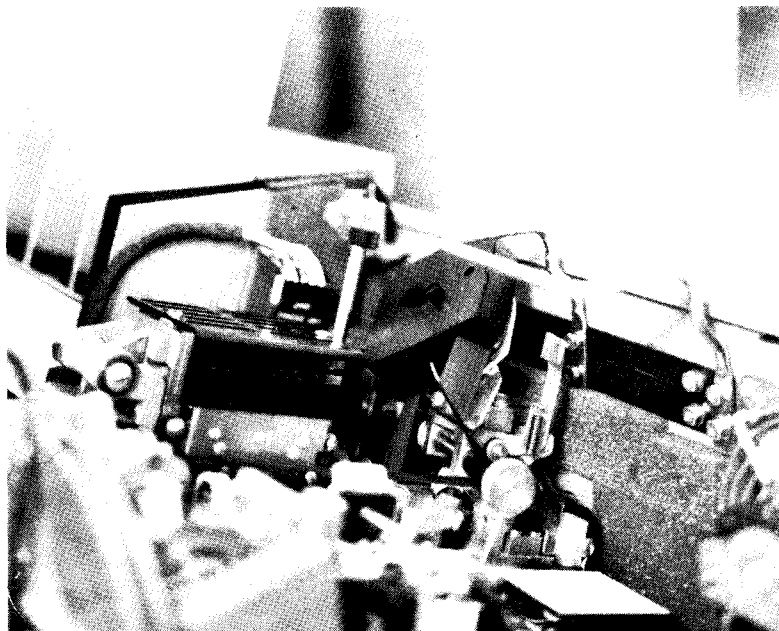

- 2 Slip the ribbon into the ribbon drive.

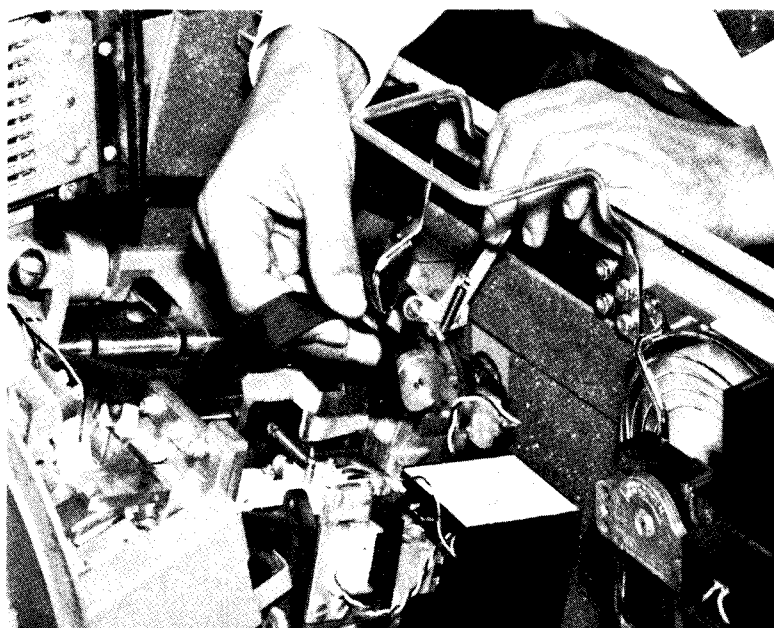

- 3 Position the ribbon under the guide plate and under the front and back guide.



- 4 Turn the knob on the ribbon drive counterclockwise to take up slack in the ribbon.

*Note:* Apply light pressure with one finger under the ribbon during the take-up operation. No folds should be allowed to feed into the ribbon cartridge. When the take-up operation is complete, check the ribbon path to ensure there are no folds in the ribbon and the ribbon is not wrapped around any of the guides or rolls.

- 5 Close and lock the print unit.
- 6 Close the MFCU top covers.
- 7 Press and hold the NPRO key to feed the ribbon. Release the NPRO key.

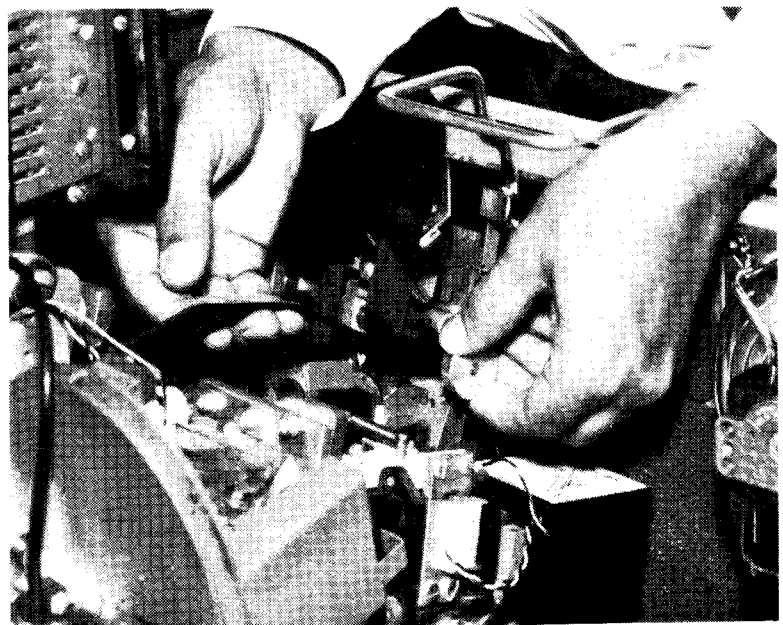

Raise the top cover to see if the ribbon is feeding properly. If the ribbon is feeding properly, close the top cover and resume program operations.

## EMPTYING THE MFCU CHIP BOX

- 1 Open the MFCU top cover. Lift the latch to release cover. Pivot the outer top cover toward front of the machine.

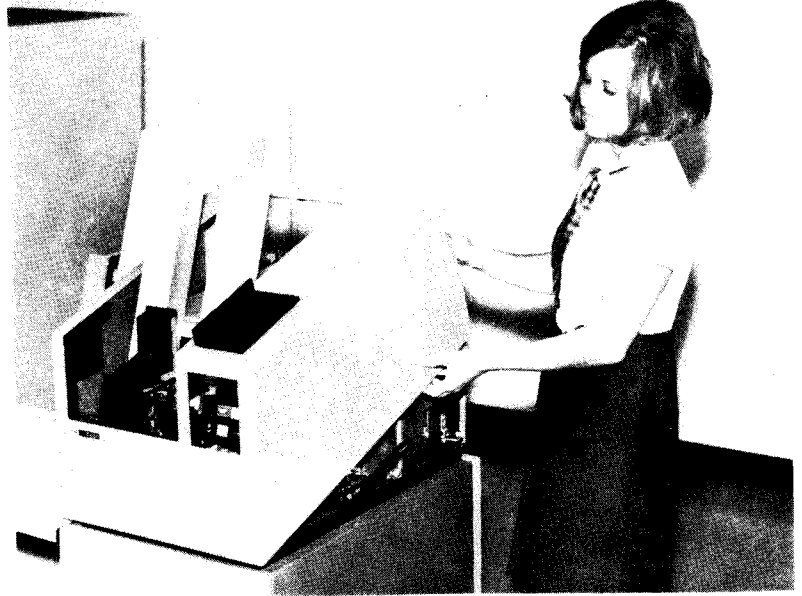

- 2 Lift the chip box up and out toward front of the machine.

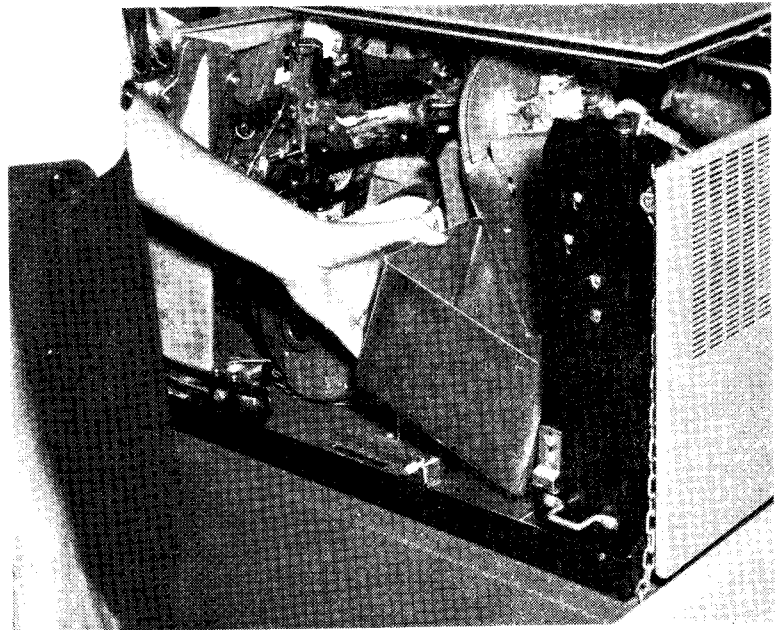

- 3 Empty the chip box.
- 4 Replace the chip box.
- 5 Close the MFCU top cover.
- 6 Press START to turn off CVR and CHIP lights on the MFCU operator's panel.





## Chapter 4. IBM 2560 Multi-Function Card Machine

- Controls and Indicators
- Power On and Ready Procedures
- Last Card Procedure
- Card Jams
- Changing the MFCM Print Ribbon
- Setting the MFCM Print Heads
- Emptying the MFCM Chip Box

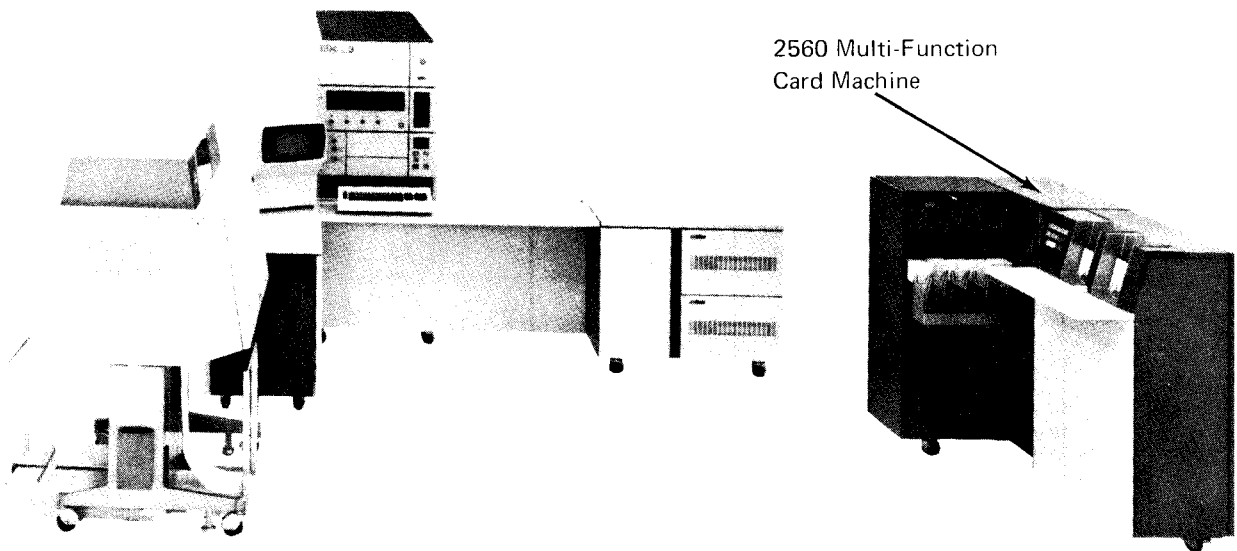

## CONTROLS AND INDICATORS

The 2560 controls and indicators (Figure 17) are located at the left of the secondary feed hopper on the front of the 2560.

### Indicator Lights

These lights indicate the following:

**SECONDARY HOPPER CHECK:** A card misfeed occurred from the secondary hopper. To turn the light off, remove all cards from the hopper, repair or replace any damaged cards, place the cards back in the hopper, and press START.

**PRIMARY HOPPER CHECK:** A card misfeed occurred from the primary hopper. To turn the light off, remove all cards from the hopper, repair or replace any damaged cards, place the cards back in the hopper, and press START.

**MACHINE CHECK:** A malfunction occurred in the 2560 (PRIMARY READY and SECONDARY READY lights also turn off). To turn off the MACHINE CHECK light, remove all cards from the hoppers and press NPRO. If the trouble persists, contact IBM for hardware support.

**ATTENTION:** One of the following conditions exists:

1. A stacker is full.
2. One or more of the machine covers is open.
3. The chip box is full or out of position.
4. The print interlock arm is not locked.
5. The hand wheel (see *Punch Station* later in this chapter) is engaged or a hand crank is inserted.

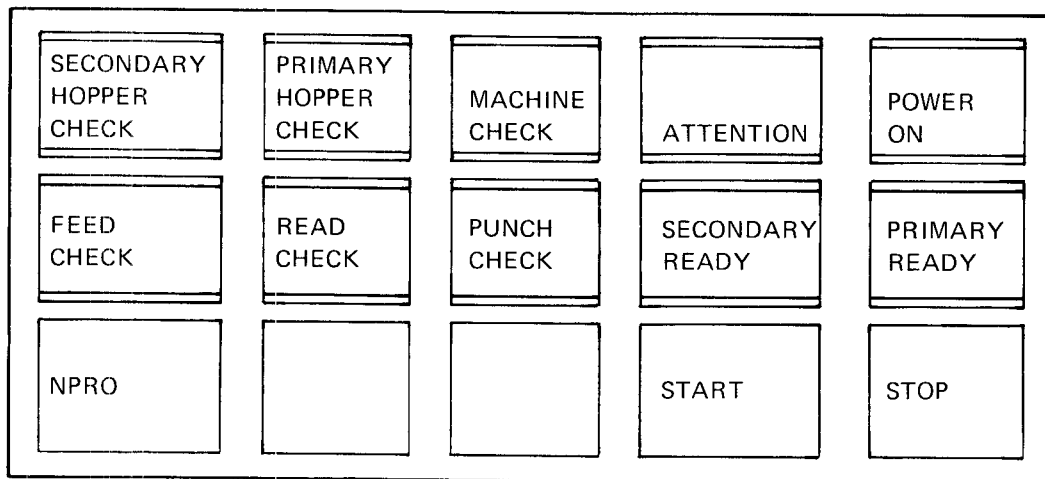

Figure 17. 2560 Indicator Lights and Control Keys

If the trouble persists, call IBM for hardware support.

When ATTENTION is on, the PRIMARY READY and SECONDARY READY lights turn off; the I/O ATTENTION light on the system control panel may also turn on. The ATTENTION light turns off when you correct the condition.

**POWER ON:** System power is on.

**FEED CHECK:** One of the following conditions exists:

1. A card in the path is not positioned correctly. To recover, follow the procedures listed under *Clearing a Card Jam* later in this chapter and press the NPRO key.
2. A machine cover is open during a read, punch, feed, or print operation. Close the cover and press NPRO to turn the light off.

The I/O ATTENTION light on the system control panel may turn on along with FEED CHECK.

If neither of the two previous conditions exists, the 2560 has malfunctioned. Empty both hoppers and press NPRO to ready the device.

**READ CHECK:** A read error occurred or an invalid code was read. The I/O ATTENTION light may also turn on. The READ CHECK light turns off when you respond to a message on the CRT screen, if one is displayed, or when you remove all the cards from the hoppers and press NPRO.

**PUNCH CHECK:** A punch error occurred while punching output. The I/O ATTENTION light may also turn on. The PUNCH CHECK light turns off when you respond to a message on the CRT, if one is displayed, or when you remove all cards from the hoppers and press NPRO.

**SECONDARY READY:** The secondary hopper is ready to process cards.

**PRIMARY READY:** The primary hopper is ready to process cards.

## Control Keys

**NPRO (Nonprocess Runout):** Press this key to clear all cards from both the primary and secondary card paths without processing them. Remove all cards from both hoppers before you press NPRO. Any cards in the primary card path go to stacker 1; cards from the secondary path go to stacker 5 if you have a 2560 Model A1 or stacker 4 if you have a 2560 Model A2.

**START:** Press this key to start the 2560 (see *Power On and Ready Procedures* later in this chapter). When you press START, the PRIMARY READY and SECONDARY READY indicators turn on. The START key is also used to restore the ready status after a hopper check condition.

**STOP:** Press this key to stop 2560 operations. Any reading, punching, or printing operations already in progress are completed before the machine stops.

## Usage Meter

The 2560 usage meter records time from the time the first 2560 command is received until the time that runout is complete. Runout is accomplished by pressing the NPRO key or by using the last card procedure.

## POWER ON AND READY PROCEDURES

1. Turn on the system POWER switch on the system control panel. This turns on the 2560 FEED CHECK light.
2. Remove cards from the 2560 hoppers.
3. Press NPRO. (FEED CHECK turns off).
4. Remove cards from the stackers.
5. Place the cards to be processed 9-edge first, face down in the appropriate hopper.
6. Place the card weight on top of the cards in the hopper.
7. Press START. The first cards in the hoppers are fed into the pre-read station and the appropriate hopper READY indicators turn on. The 2560 is now ready for program operation.

*Note:* The card lever in the primary hopper is on the right side of the hopper; the lever in the secondary hopper is on the left. Be sure you use the correct card weight. The base of the card weight of the 2560 has card-lever cutouts on both the left and right sides.

## LAST CARD PROCEDURE

When the last card is fed from either hopper, the READY light for that hopper turns off and a message is displayed on the CRT screen. You then must:

1. Load additional cards, if they are to be processed in the same job, and press START to turn on the hopper READY light.
2. Press START without loading more cards to restore the ready status for the hopper and allow the last card to be processed. If the other hopper is being used and is not empty, processing continues with the cards in that hopper until the last card procedure is needed.

*Note:* If using the 2560 as the system input device, the last job should be run in halt mode so the above procedure does not cause extraneous error messages.

## CARD JAMS

To clear a card jam in the 2560, you must be familiar with the card path, the CHECK light indications that signal a card jam, and the procedures for opening and closing the 2560 covers.

### Card Path

Card jams can occur anywhere in the card path. Figure 18 shows the card transport area as it looks when viewed from behind the machine. The card path through the 2560 is shown in Figure 19. Once past the prepunch station, cards from both hoppers follow the same path. The figure also identifies the major sections of the transport area.

*Note:* Your 2560 may or may not be equipped with the print feature. In any case, the preprint position, print station, and postprint position are always present.

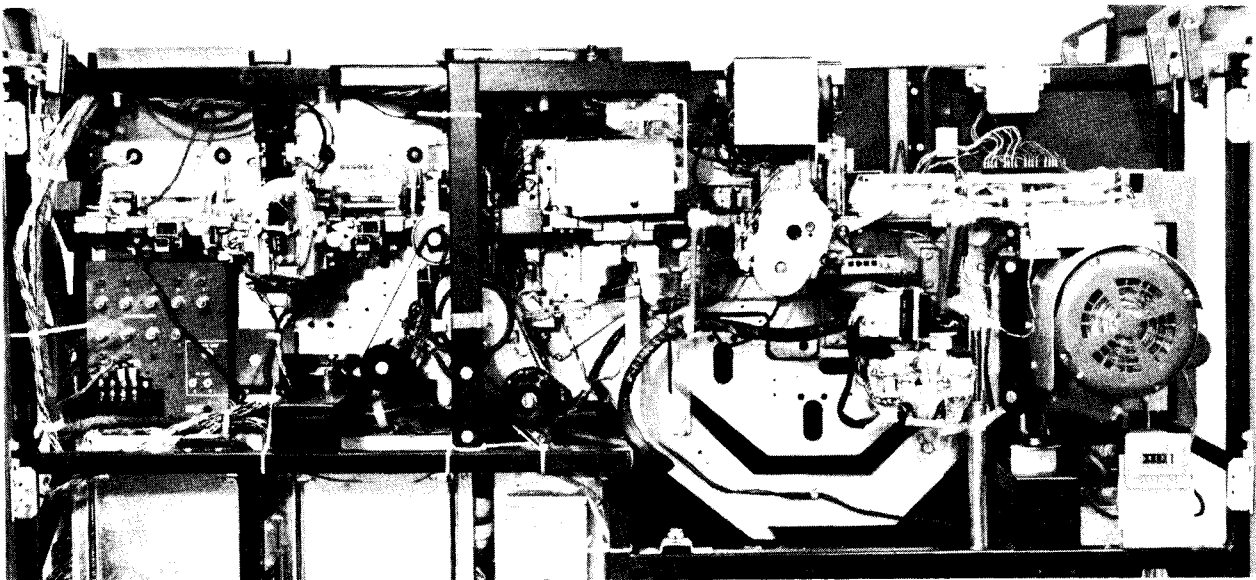

Figure 18. 2560 Card Transport Area

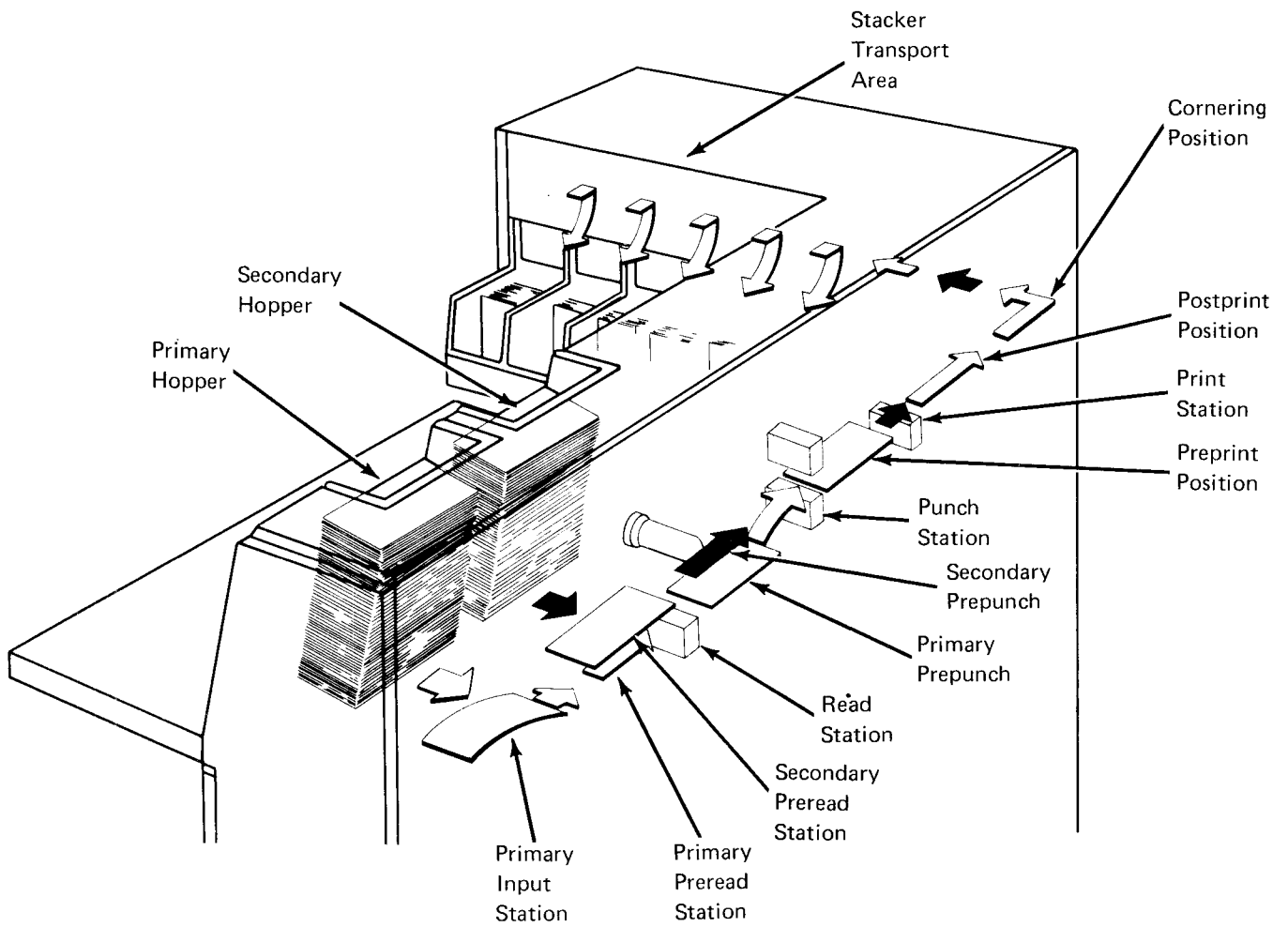

Figure 19. 2560 Card Path

## CHECK Light Indications

This discussion is intended to help you determine the reason for a CHECK light and to show you the proper procedure for correcting the condition.

**SECONDARY HOPPER CHECK Light:** A bent or damaged card is in the secondary hopper. Straighten or repair the card, replace it, and press START.

**PRIMARY HOPPER CHECK Light:** A bent or damaged card is in the primary hopper. Straighten or repair the card, replace it, and press START.

**FEED CHECK Light:** A card failed to feed or a card jam occurred. Remove cards from both hoppers and press the NPRO key to clear the card. Place the cards back in the hopper and restart. If the NPRO key is inoperative, a card jam in the prepunch station, punch station, or the stacker transport area is indicated. Remove all jammed cards and restart.

## Opening and Closing 2560 Covers

The 2560 has six interlocked covers; three on top, two in back and one in front. You open the top and rear covers from the back of the machine.

In this procedure, left and right are as viewed from behind the machine.

1. Press the cover latch under the *right* top cover in and lift the cover up. If your machine does not have a latch, grasp the cover at the hand opening and lift.
2. Lift the *left* top cover up.
3. Lift the transport area cover up.
4. Press down on the button at the top of the *right* back door and swing the door open. If your machine does not have a latch, grasp the back door at the hand opening and pull it open.
5. Swing the *left* back door open.

You now have access to the entire transport area. When you need to remove a card jam or perform other operations, you need only open the covers that give you access to the problem area.

You must close the covers in the reverse order so that as you close each cover you lock the one closed previously.

1. Close the *left* back door.
2. Close the *right* back door and be sure it latches.
3. Close the cover above the stacker transport area.
4. Close the *left* top cover.
5. Close the *right* top cover and be sure it latches.

If the covers are not closed properly, the ATTENTION light remains on.

## Clearing a Card Jam

### *Primary Input Station*

1. Open the necessary covers.
2. Raise the card guide.
3. Remove the card.
4. Close the card guide.
5. Close the covers.
6. Press NPRO.
7. Place the cards back in the hopper.
8. Press START.

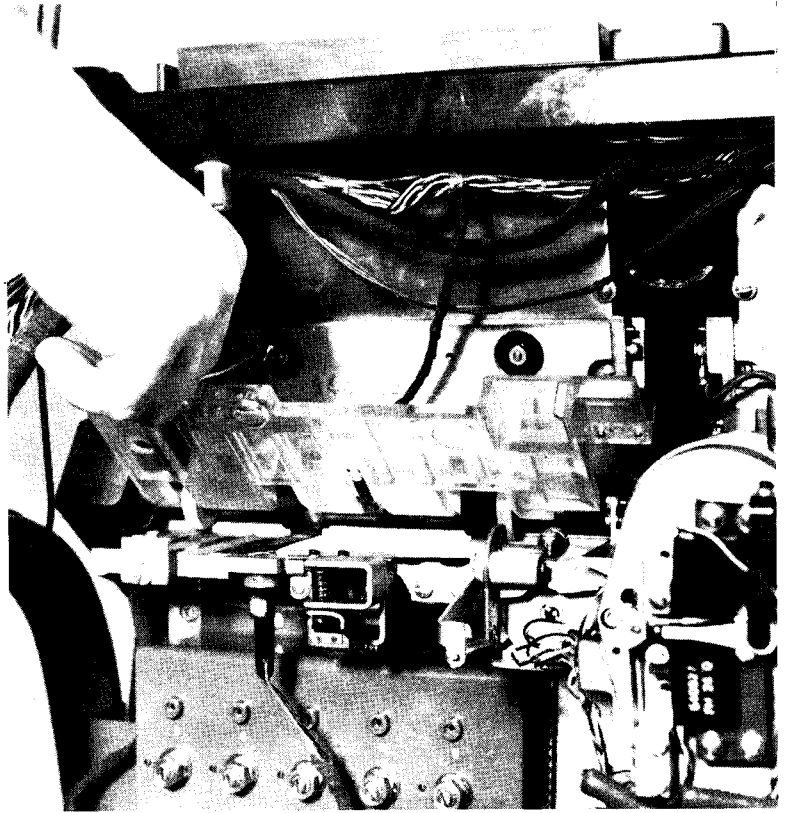

### *Primary Preread Station*

The primary preread station is located just below the secondary preread station.

1. Open the necessary covers.
2. Pull out the holding knob and lower the entire metal card guide assembly.
3. Remove the card.
4. Close the metal card guide assembly by:
  - a. Pulling back on the holding knob.
  - b. Raising the guide into position.
  - c. Releasing the knob so that it returns into the slotted position.
5. Close the covers.
6. Press NPRO.
7. Place the cards back in the hopper.
8. Press START.

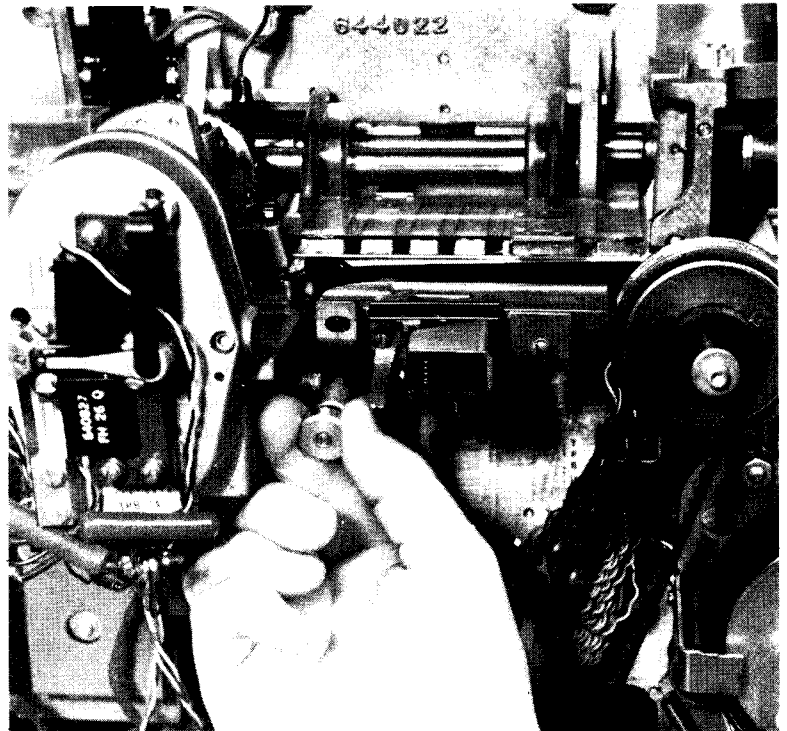

### *Secondary Preread Station*

The secondary preread station is located just above the primary preread station.

1. Open the necessary covers.
2. Lift up the plastic card guide.
3. Remove the card.
4. Close the plastic card guide.
5. Close the covers.
6. Press NPRO.
7. Place the cards back in the hopper.
8. Press START.

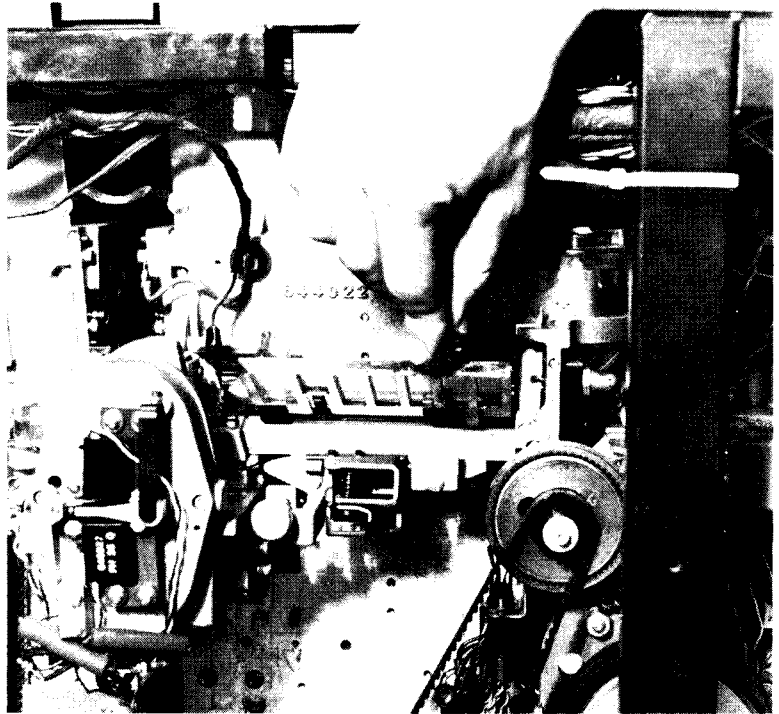

### *Read Station*

Cards are held in the read station by a pressure roller.

1. Open the necessary covers.
2. Grasp the pressure roller release lever and pull it to the left.
3. While holding the lever to the left, slide the card forward or backward out of the read station. If you slide the card backwards, it may be necessary to lower or raise the card guides in the preread station.
4. Return the pressure roller release lever to its original position.
5. Close the covers.
6. Press NPRO.
7. Place the cards back in the hopper.
8. Press START.

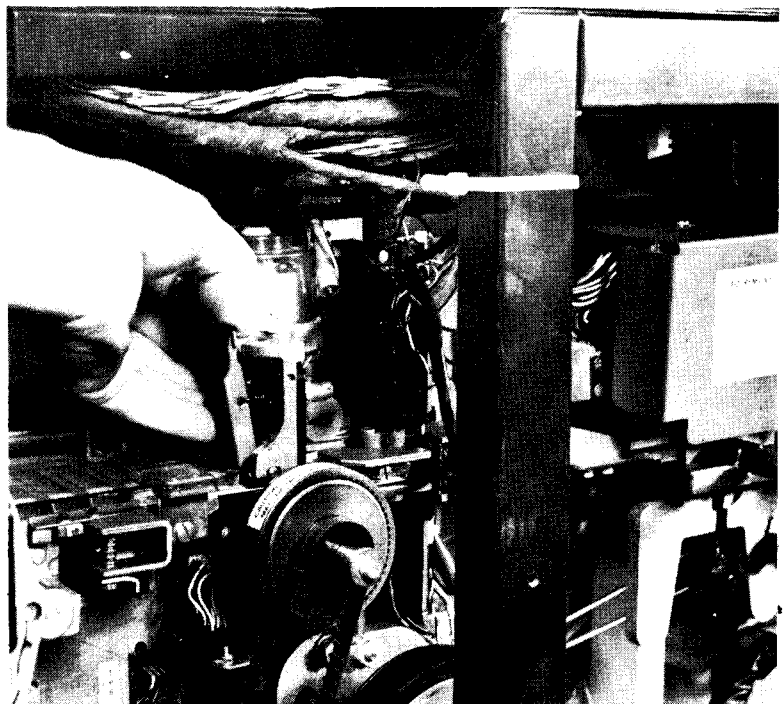



*Punch Station*

1. Open the necessary covers.
2. Press down on the spoon-shaped pressure roller release lever.
3. While holding the lever down, move the card forward or backward out of the punch unit. If you cannot get the card out, follow the procedures under *Special Punch Station Procedures*.
4. Release the pressure roller release lever.
5. Close the covers.
6. Press NPRO.
7. Place the cards back in the hopper.
8. Press START.

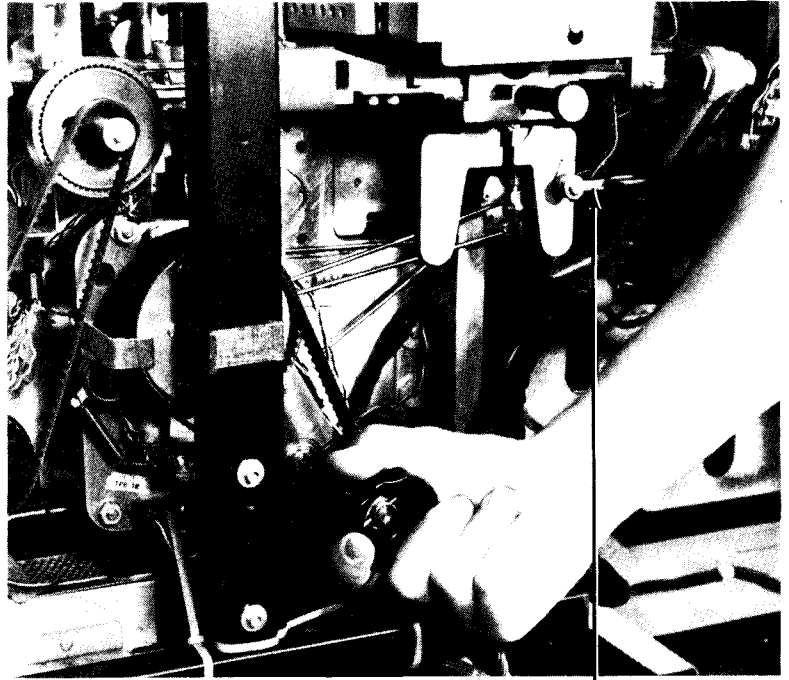

Spoon-Shaped  
Pressure Roller  
Release Lever

*Special Punch Station Procedures:* When a jammed card is not freed by holding down the pressure roller release lever, the punch is probably holding the card. To raise the punch from the card, turn the hand wheel in either direction until the punch is released. If it is difficult to turn the hand wheel, you can use the crank stored in the compartment under the stacker transport area cover:

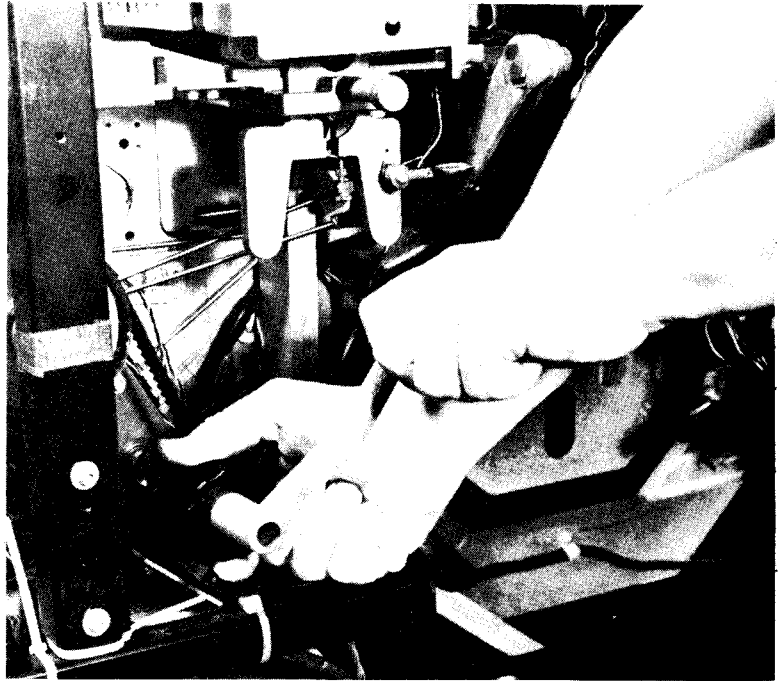

1. Press the hand wheel in and place the crank into the hand wheel.
2. While you hold the hand wheel in, turn it about one-half revolution. This should let you remove the card. If so, go to step 3. If the card is still jammed, you must remove the card guide. Go to step 4.
3. Release the hand wheel mechanism to free the crank. The hand wheel returns to its normal position. Go to step 10.
4. Release the hand wheel mechanism to free the crank. The hand wheel returns to its normal position.
5. Turn the release knob counterclockwise until it is disengaged from the punch unit. (The knob remains attached to the card guide.)
6. Pull the card guide straight out.
7. Remove the jammed card.
8. Replace the card guide.
9. Turn the release knob clockwise until it is tightly secured to the punch unit.
10. Close the covers.
11. Press NPRO.
12. Place the cards back in the hopper.
13. Press START.

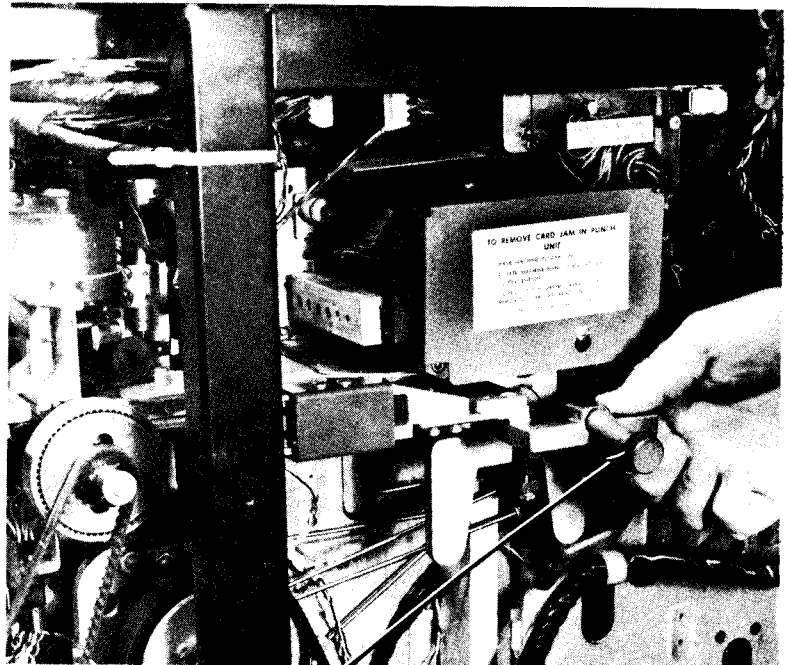

Release Knob

### *Preprint Position*

1. Open the necessary covers.
2. Raise the plastic card guide.
3. Remove the card.
4. Replace the plastic card guide.
5. Close the covers.
6. Press NPRO.
7. Place the cards back in the hopper.
8. Press START.

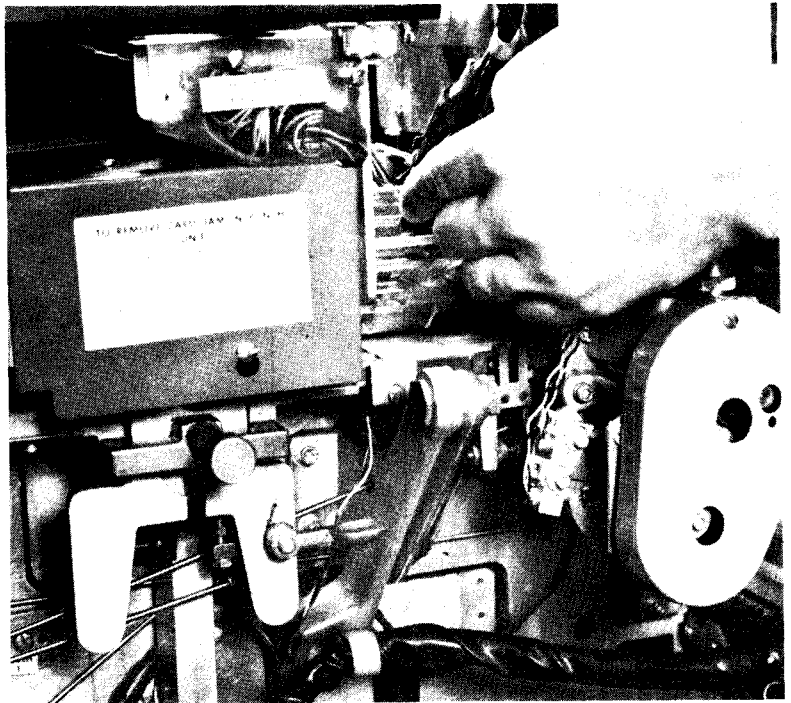

### *Print Station*

1. Open the necessary covers.
2. Hold the pressure-roller release lever up, and slide the card out. If you cannot get the card out, see *Removing the Platen*.
3. Release the pressure roller release lever.
4. Close the covers.
5. Press NPRO.
6. Place the cards back in the hopper.
7. Press START.

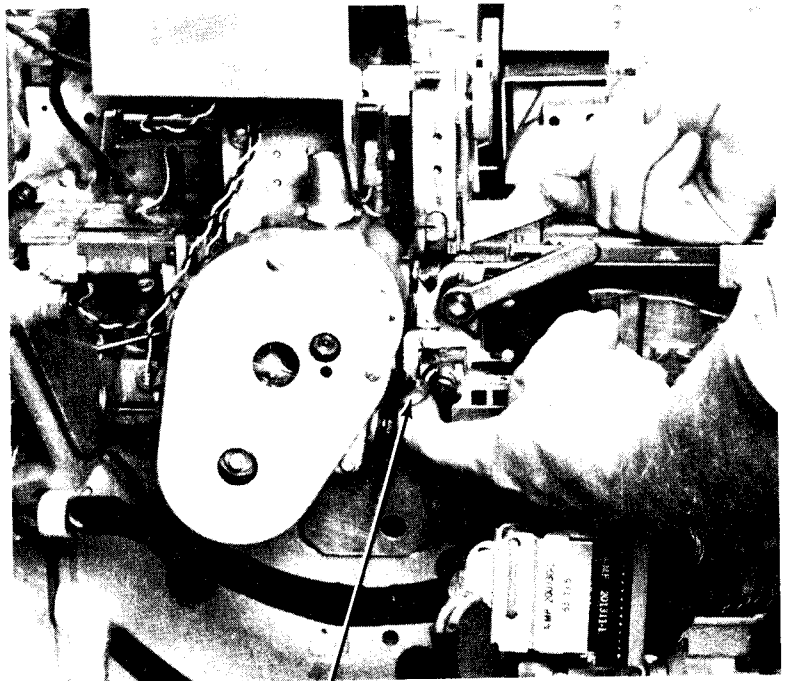

Pressure Roller Release Lever

*Removing the Platen (Figure 20):*

1. Turn both platen knobs counterclockwise about one full turn.

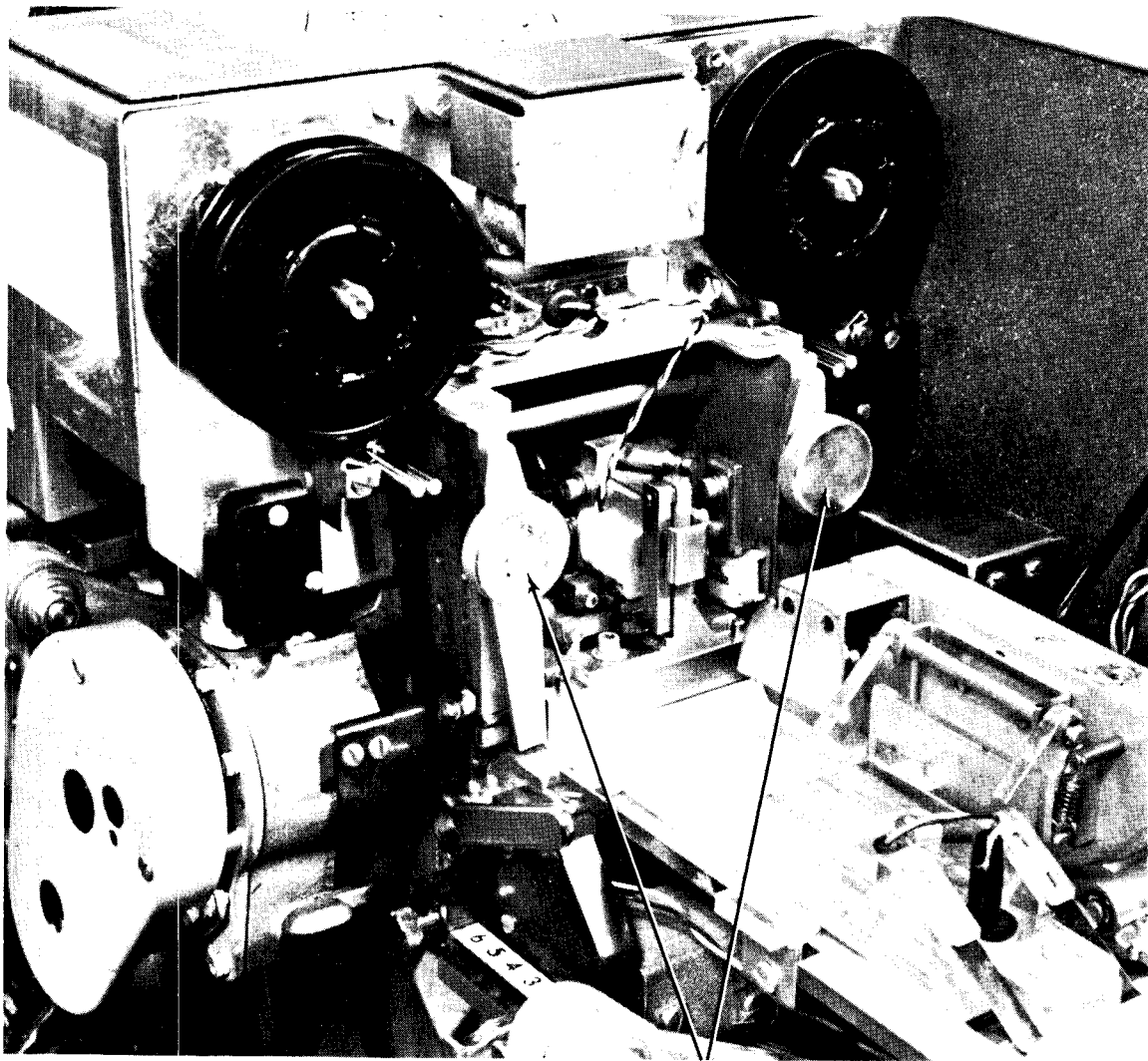

Figure 20. Platen Assembly

Platen Knobs

2. Move the platen clamps sideways away from the platen.
3. Grasp the platen firmly and pull it slightly outward and up. Remove the platen and set it on top of the print assembly.

**CAUTION**

Use care in handling the platen so that the wires attached to it are not loosened.

4. Grasp the pressure roller release lever, pull it out, and slide the card out. Be careful not to change the position of the print ribbon.
5. Release the pressure roller release lever.

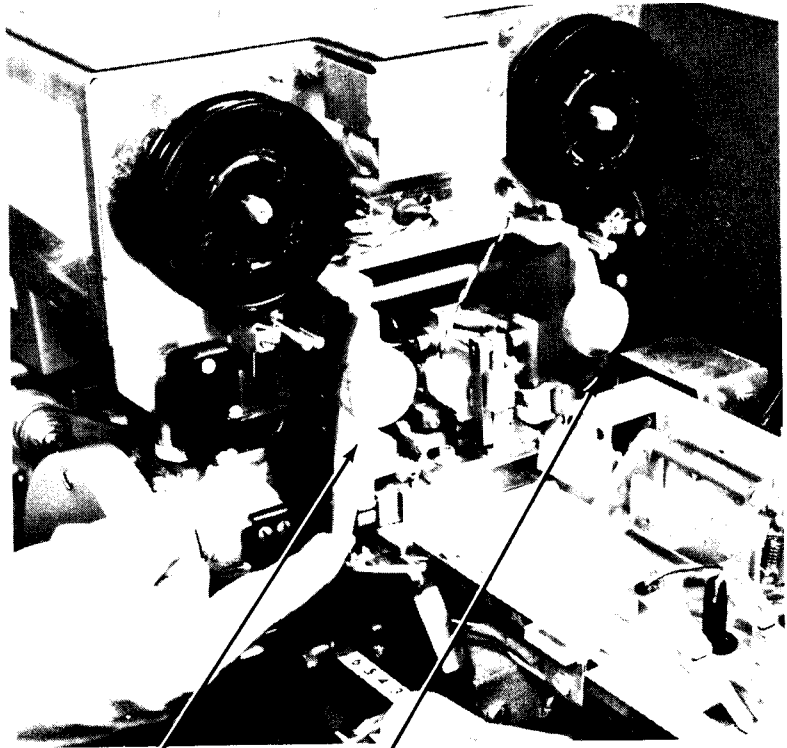

Platen Clamp

Platen Clamp

6. Replace the platen by tilting it forward about 45° and lowering it into place. The short shafts extending from the bottom of the platen must fit into the slots provided for them in the print unit.
7. Return the platen clamps to their original positions.
8. Holding the clamps firmly in place, tighten the platen knobs securely by turning them clockwise.
9. Close the covers.
10. Press NPRO.
11. Place the cards back in the hopper.
12. Press START.

Print Head  
Cleaning Tool

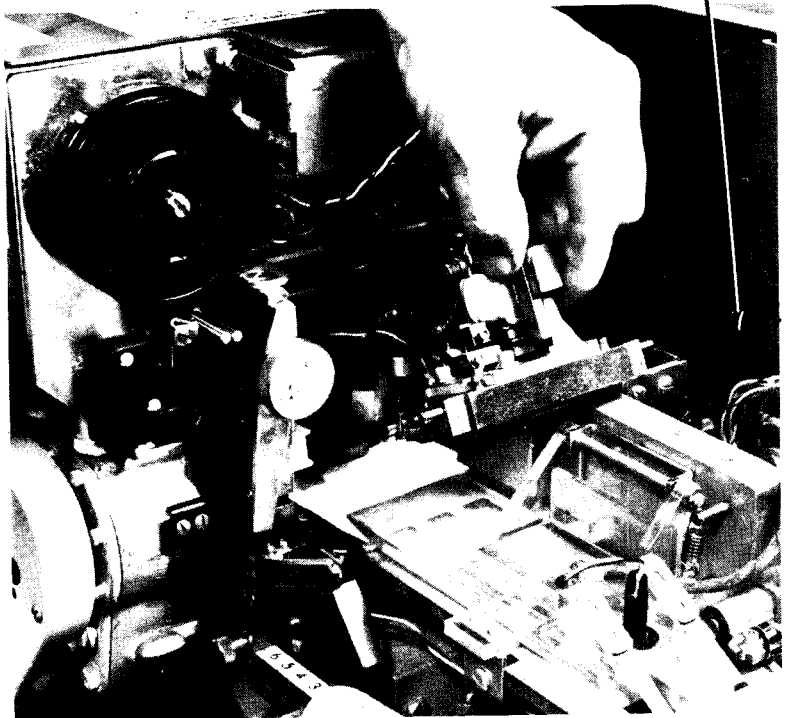

*Postprint Position*

1. Open the necessary covers.
2. Raise the plastic card guide.
3. Remove the card.
4. Close the plastic card guide.
5. Close the covers.
6. Press NPRO.
7. Place the cards back in the hopper.
8. Press START.

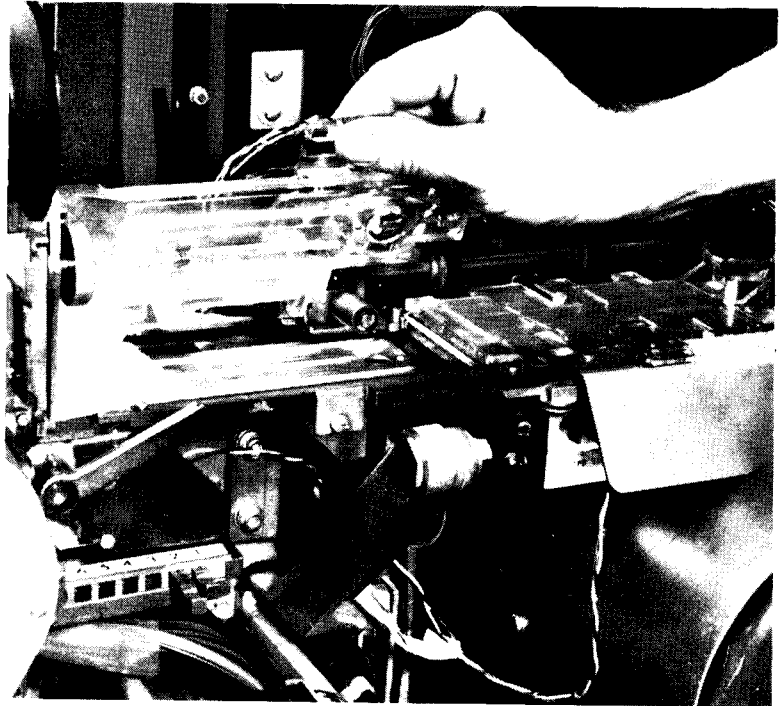

*Cornering Position*

1. Open the necessary covers.
2. Lift the plastic card guide.
3. Remove the card.
4. Lower the plastic card guide.
5. Close the covers.
6. Press NPRO.
7. Place the cards back in the hopper.
8. Press START.

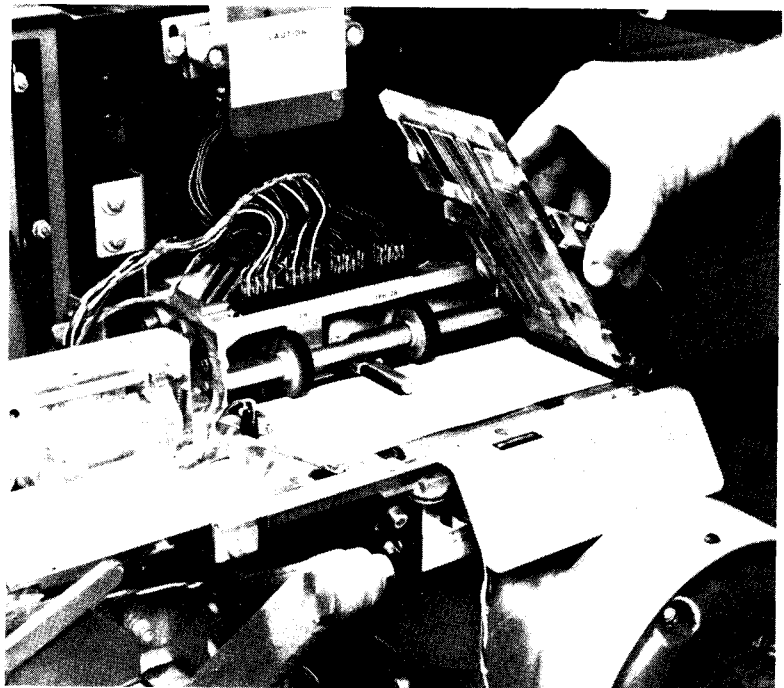

### *Stacker Transport Area*

The stacker transport area has no removable card guides or card covers.

1. Open the necessary covers.
2. Turn the hand wheel in a clockwise direction to turn the feed rollers until the cards feed into the appropriate stackers. If it is difficult to turn the hand wheel, use the crank stored in the compartment under the stacker transport area cover.
  - a. Press the hand wheel in and place the crank into the hand wheel.
  - b. While you hold the hand wheel in, turn the crank.
  - c. Release the hand wheel mechanism to free the crank. The hand wheel returns to its normal position.
3. Close the covers.
4. Press NPRO.
5. Place the cards back in the hopper.
6. Press START.

*Note:* If the procedure does not remove the jam, you must pull the cards out of the transport area by hand.

## CHANGING THE MFCM PRINT RIBBON

The print ribbon can be changed from either the front or the back of the 2560. The view shown here is of the ribbon guides as seen from the end of the machine with the platen removed.

1. Open the necessary covers, including the small one in the front, just to the left of the operating panel.
2. Remove the platen assembly as described under *Print Station* earlier in this section.
3. Note the position of the ribbon on both sides of the print unit. Note also how the ribbon is held between the guides and how it slides under the print unit.
4. Slide both spools off the studs they are mounted on.
5. Gently slide the ribbon back and forth away from the print unit and out of position.

*Note:* If you are also going to change the print positions of the print heads, you should now perform the cleaning procedures given in the procedure *Setting the MFCM Print Heads*.

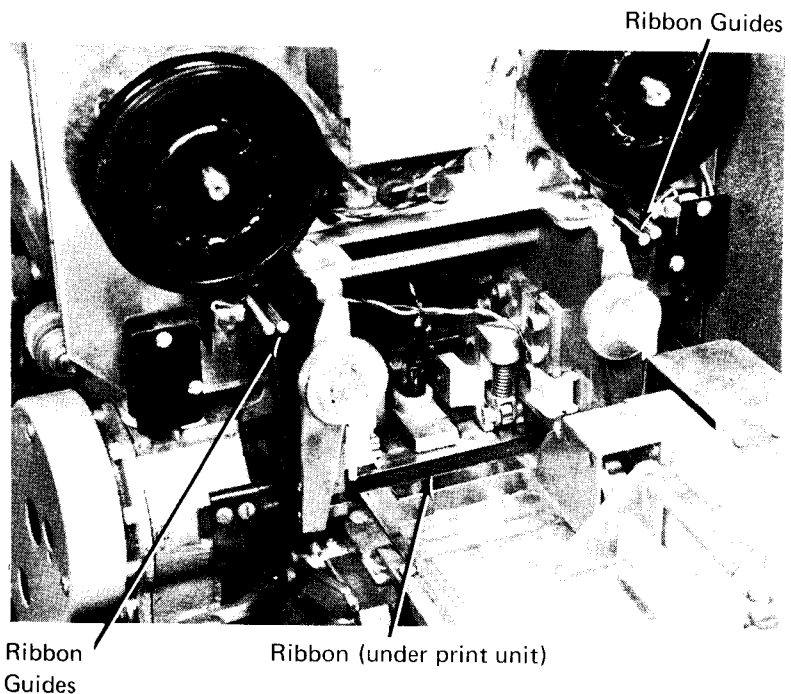

6. Remove the ribbon from one of the spools.
7. Thread the free end of the new ribbon onto the spool. Wrap enough ribbon on the spool to ensure that the metal eyelet is on the spool.
8. Hold one spool in each hand and unwrap about 12 to 18 inches from the full spool.
9. Hold one spool on each side of the print unit, lower the ribbon to the bottom face of the print unit, and gently slide the ribbon under the print unit.
10. Check to be sure that the ribbon is under the guides on the bottom edge of both sides of the print unit and that the outside edge of the ribbon is under the lip of the bottom plate of the print unit.



11. Place the spools on the ribbon-spool studs, so the small guide posts of the print unit fit into the holds in the ribbon spools.
12. Place the ribbon in the small ribbon-guide clips and around the inside of the ribbon-guide rollers on each side of the print unit.
13. Be sure the ribbon is on the outside of the lower ribbon guide on the front side of the print unit. Then turn either of the ribbon spools until the slack has been taken up.
14. Reinstall the platen assembly as described under *Print Station* earlier in this section.
15. Close all covers.
16. Press START.

#### SETTING THE MFCM PRINT HEADS

The print unit in the 2560 has up to six print heads, each capable of printing in one line position on the cards. There are 25 line positions on the cards. You set each print head to the desired line number by adjusting the line selection levers. The first print head must print the top line on the card, the second print head the second line, and so on.

1. Press NPRO to clear all cards from the machine.
2. Open the necessary covers.
3. Check for dust accumulation around the print heads. This dust can cause smudged printing on the first few cards or it may prevent setting the print heads to adjacent positions. If cleaning is not required, go to step 8.
4. Remove the platen as described under *Print Station* earlier in this section.
5. Carefully lift the ribbon to expose the print heads.

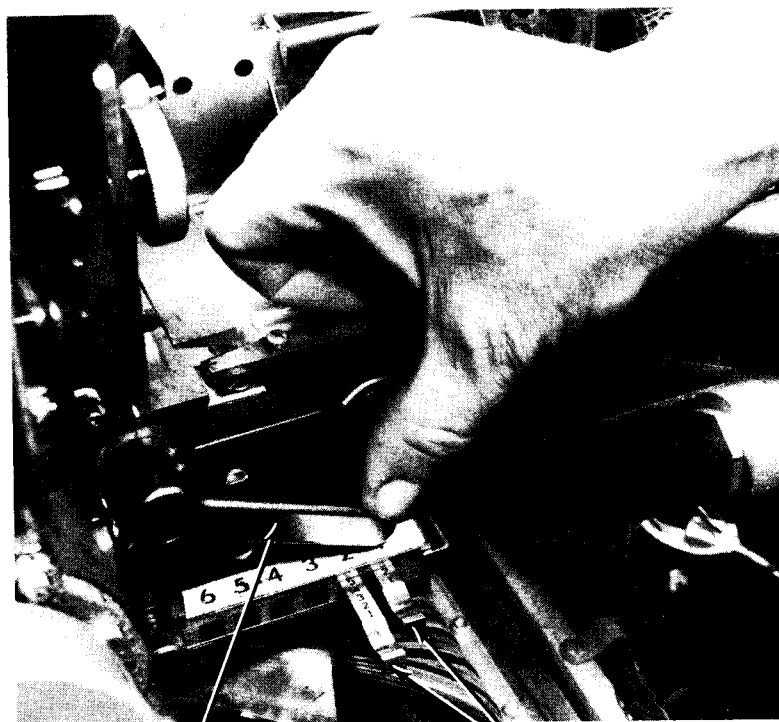

Interlock Arm

Line Selection Levers

6. Place the forked end of the cleaning tool over each print head and move the tool up and down.
7. Replace the platen as explained in the *Print Station* procedure.
8. Push the interlock arm down to release the line selection levers.
9. Push or pull each line selection lever to the appropriate printing position for the six print heads.
10. Return the interlock arm to the raised (locked) position. If the arm will not move to the locked position, one of the selection levers may not be seated properly. Readjust each lever and raise the interlock arm. If this arm is not in the locked position, the ATTENTION light turns on when the START key is pressed.
11. Close all covers.
12. Press START.

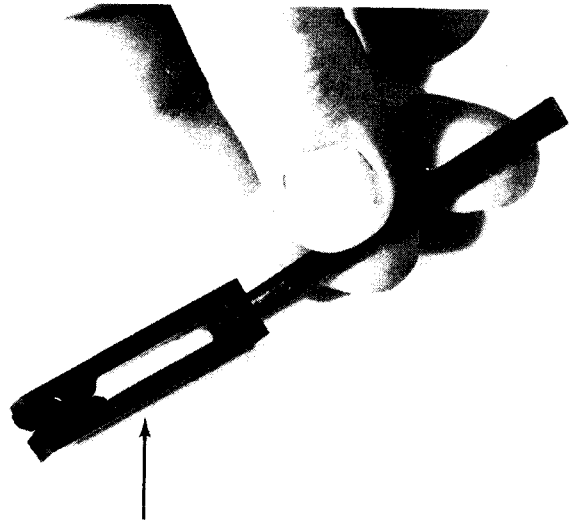

Cleaning tool. See *Removing the Platen* for view showing location of cleaning tool.

#### EMPTYING THE MFCM CHIP BOX

The chip box is under the punch station, at the back of the machine.

1. Open the necessary covers.
2. Remove the chip box and empty it.
3. Replace the chip box, and position it correctly on the spring-loaded shelf.
4. Close all covers.
5. Press START.

If the chip box is positioned incorrectly, the ATTENTION light turns on.

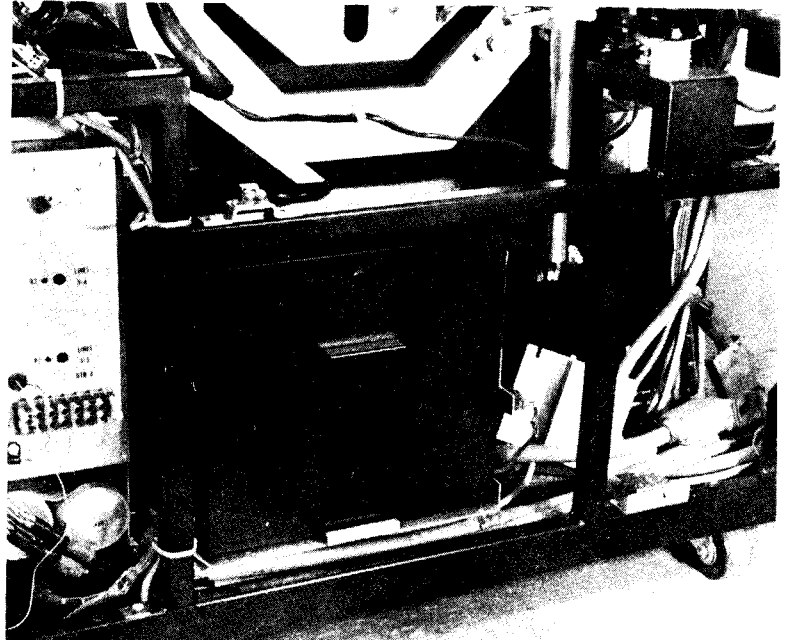

- Controls and Indicators
- Power On and Ready Procedures
- Last Card Procedures
- Clearing a Card Jam
- Emptying the 1442 Chip Box

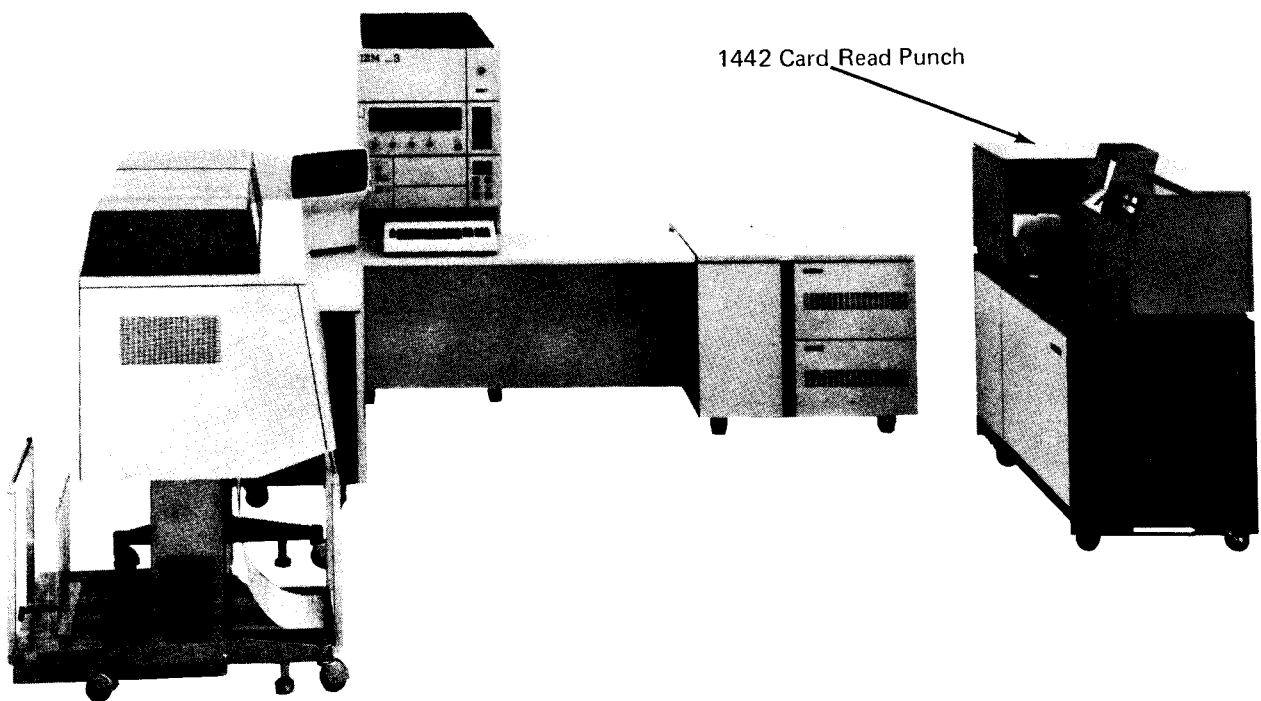

## CONTROLS AND INDICATORS

All of the 1442 controls and indicators are on a single panel to the right of the card hopper. Eight of the indicators are on a backlit panel.

### Keys

The operator's panel (Figure 21) contains three keys:

**START:** Press the START key to place the 1442 in a ready status (see *Power On and Ready Procedures*). The START key is also used to return the 1442 to a ready status after 1442 STOP has been pressed and/or to initiate the last card sequence.

**STOP:** Press the STOP key to take the 1442 out of ready status. The READY light turns off.

**NPRO (Nonprocess Runout):** Press the NPRO key to clear all cards from the card feed path. The hopper must be empty and the READY light must be off before the NPRO key will operate.

NPRO is also used to turn off the CHECK light and HOPR sense light when the system is turned on. This procedure ensures that the card feed path is clear.

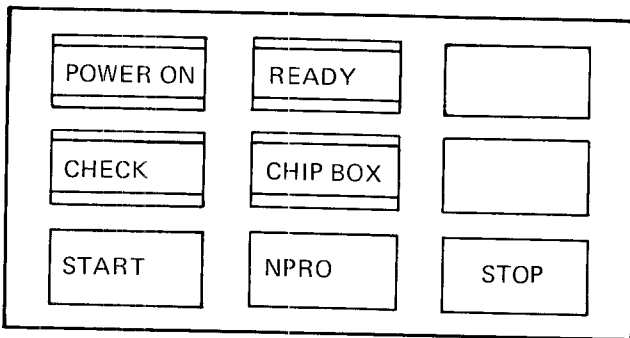

Figure 21. Operator's Panel

### Status Lights

Four lights above the keys on the operator's panel indicate the following 1442 status conditions.

**POWER ON:** System power is turned on.

**READY:** The 1442 is ready to accept instructions from the processing unit. The READY lights turn on if the following conditions are met:

1. System power on.
2. Cards in the hopper - except for last card sequence. Cards can also be in the card feed path if you press START after you press STOP.
3. CHECK light off.
4. Stacker not full.
5. START pressed.

**CHIP BOX:** The chip box is full or out of the machine. The READY light turns off when the CHIP BOX light turns on. The chip box is behind the left front cover.

**CHECK:** Any of the backlit error indicators are lit. The READY light turns off.

### Usage Meter

The 1442 usage meter records time from the time the first 1442 command is received until the time that runout is complete. Runout is accomplished by pressing the NPRO key or by using the last card procedure.

### Sense Lights

Seven lights, on a backlit panel to the left of the CHECK light (Figure 22), indicate errors in the card feed. An eighth light, OVER RUN, indicates a probable loss of data.

*HOPR*: A card failed to feed from the hopper. Press NPRO to turn off the HOPR light.

*READ STA*: A card is jammed at the read station.

*PUNCH STA*: A card is jammed at the punch station.

*TRANS*: A card is jammed in the stacker area.

*FEED CLU (Clutch)*: All cards in the card feed path have advanced one position because of an unrequested feed cycle.

*READ REG*: Read error.

*PUNCH*: Punch error.

*OVER RUN*: Data is lost. The processing unit is unable to accept data from the 1442 or provide data to the 1442 as fast as is necessary.

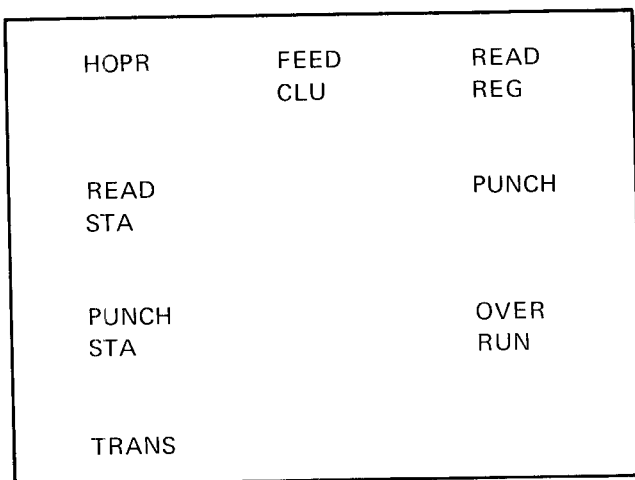

Figure 22. Sense Lights

### POWER ON AND READY PROCEDURES

1. Turn on the system POWER switch on the processing unit console.
2. Remove any cards from the 1442 card hopper.
3. Press NPRO.
4. Remove any cards from the stackers.
5. Place the cards to be processed, 9-edge first, face down in the card hopper.
6. Place the card weight behind these cards.
7. Press START. The first card in the hopper feeds to the preread station and the READY light turns on. The 1442 Card Read Punch is now ready for program operation.

### LAST CARD PROCEDURES

When the last card is fed from the card hopper, the READY light turns off and a message is displayed on the CRT screen.

Operator action is determined by the program in operation:

1. More cards are required. Place the cards in the 1442 card hopper and press START. The program resumes operation.
2. Last card sequence. Press START. The last card is processed and the program resumes operation. Before proceeding to the next job, ready the 1442.

*Note*: If a single card is being processed, it is necessary to press START twice. The first time START is pressed, the card is registered at the preread station. The READY light turns on and off. The second time START is pressed, the READY light turns on, and the card is ready to be processed as part of the last card sequence.

## CLEARING A CARD JAM

The following procedure tells you how to remove cards from the 1442 card path. The program recovery procedures with corresponding messages – what to do with the cards to continue program operations—are listed in the *IBM System/3 Model 15 System Messages*, GC21-5076.

### Indications

All of the following indicate a hopper misfeed or card jam in the 1442.

- C5, C6, C7, C8, or C9 message displayed on the CRT screen.
- READY light is not on.
- CHECK light on.
- A sense light on.

A sense light indicates the area in the card feed path where the trouble occurred. When a hopper misfeed or card jam occurs, record the error in your console log book. If the same error occurs repeatedly, it is an indication that the 1442 should be serviced.

### Removing Cards From the Card Feed Path

The 1442 card path is shown in Figure 23. The sense lights, whose names are shown in Figure 24, are lit to indicate where in the card path a card is jammed.

#### Hopper Misfeed:

1. Remove the cards from the hopper.
2. Check the bottom card for damage. All edges must be smooth. If the card is damaged, punch a new card to replace it.
3. Refer to the C5 message in the *IBM System/3 Model 15 System Messages*, GC21-5076, for the program recovery procedures.

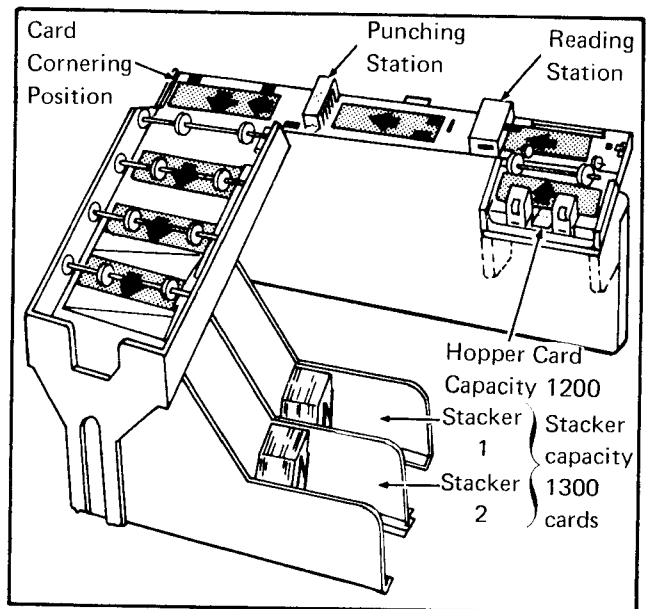

Figure 23. 1442 Card Path Schematic

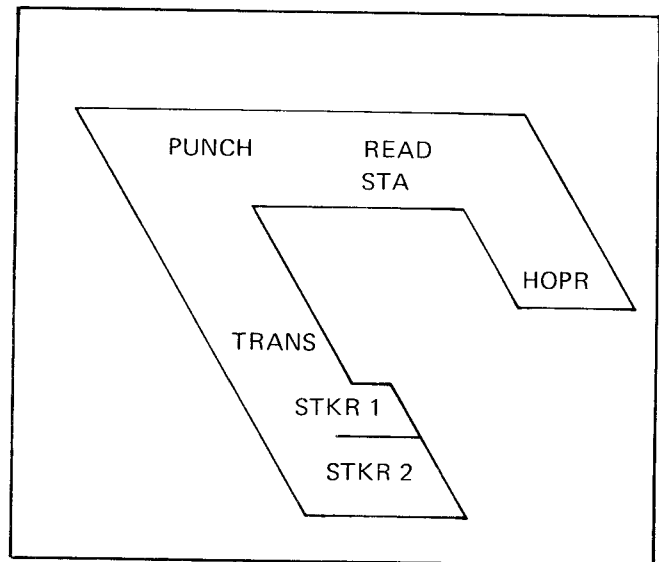

Figure 24. Card Path

*Card Jam in Card Path:*

1. Open the 1442 top covers.



2. Raise the plastic card guides and remove all cards from the card path. If a card remains jammed under the punch unit, proceed with steps 3–7; otherwise go to step 8.

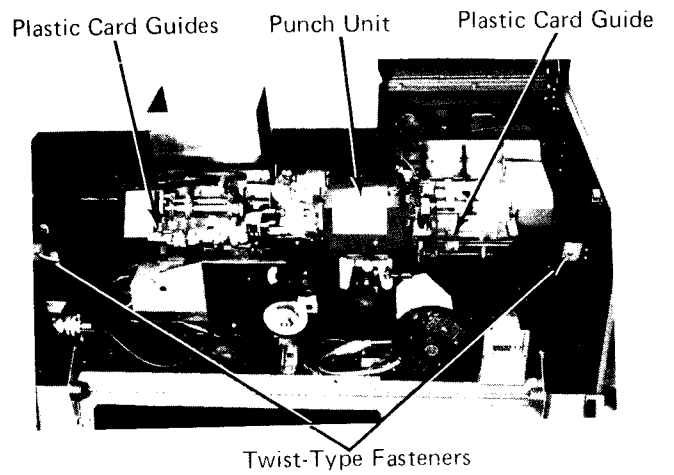

3. Open the two twist-type fasteners on the inside of the rear cover and lower the cover.

4. Turn the punch unit hand wheel clockwise at least one-half revolution. System power must be on.

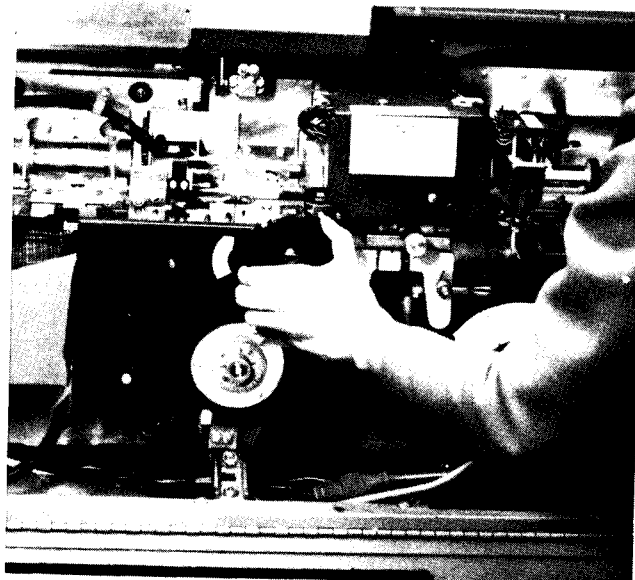

5. Push down on the punch feed release lever and pull out the card.

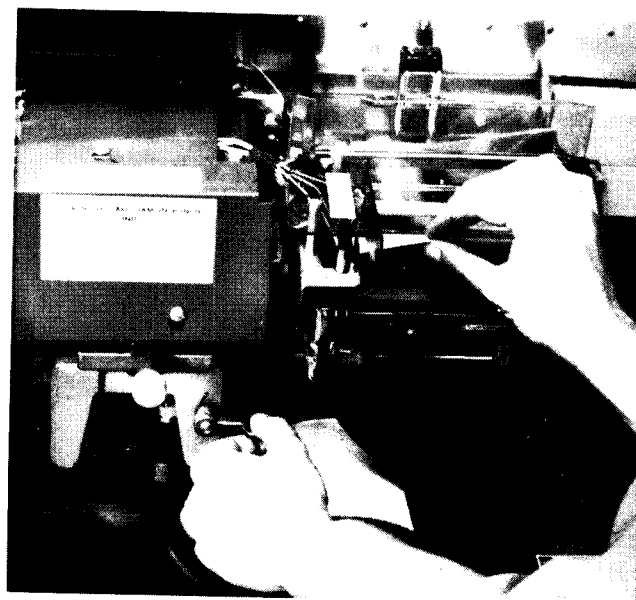



6. If the card will still not come out, unscrew and pull out the lower punch guide. Remove the card and replace the lower punch guide.
7. Raise the rear cover and close the twist-type fasteners.
8. Lower the plastic card guides to their normal positions.
9. Close the 1442 top covers.
10. Respond to the message on the CRT. (See *IBM System/3 Model 15 System Messages*, GC21-5076.)

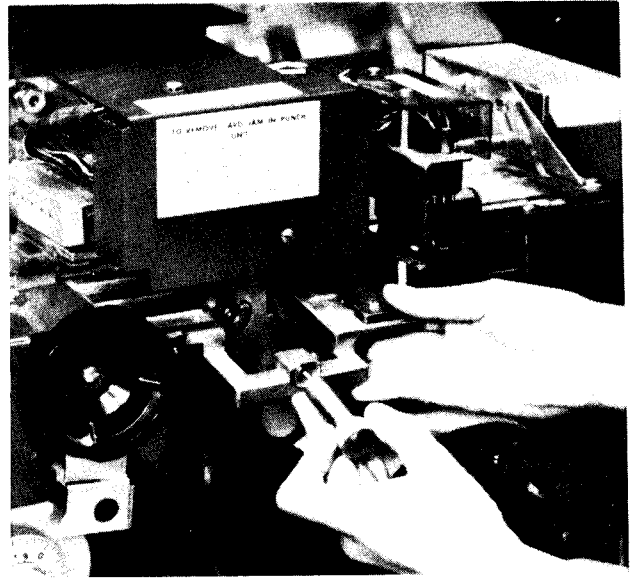

#### **EMPTYING THE 1442 CHIP BOX**

1. Open the left front cover.
2. Remove the chip box and empty it.
3. Replace the chip box on the holding tray.
4. Close the cover.



- Controls and Indicators
- Power On and Ready Procedure
- Last Card Procedures
- Clearing a Card Jam

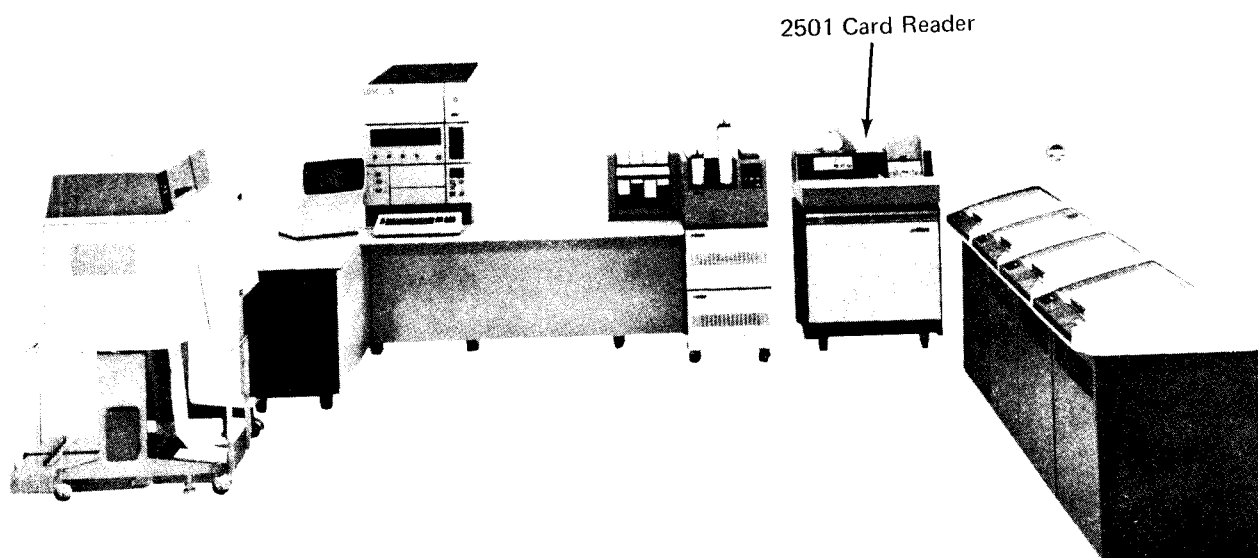

## CONTROLS AND INDICATORS

The controls and indicator lights for the 2501 are at the left of the hopper (Figure 25).

### Indicator Lights

These lights indicate the following:

**ATTENTION:** The cover is open or the stacker is full (a message is displayed on the CRT screen). To turn off the light, correct the condition, and press **START**.

**READ CHECK:** A card is mispositioned in the card path or cannot be read properly. To turn off the light, remove the cards from the hopper, press **NPRO**, replace the cards in the hopper, and press **START**.

**READY:** The 2501 is ready to receive instructions from the processing unit. The **READY** lights turn on only if all the following conditions are met:

- The system power is turned on.
- There are cards in the hopper, except during last card sequences.
- There is a card in the preread station.
- The **FEED CHECK** and **ATTENTION** lights are off.
- The machine was not stopped by pressing the **STOP** key.
- Cards were not run out by pressing the **NPRO** key.

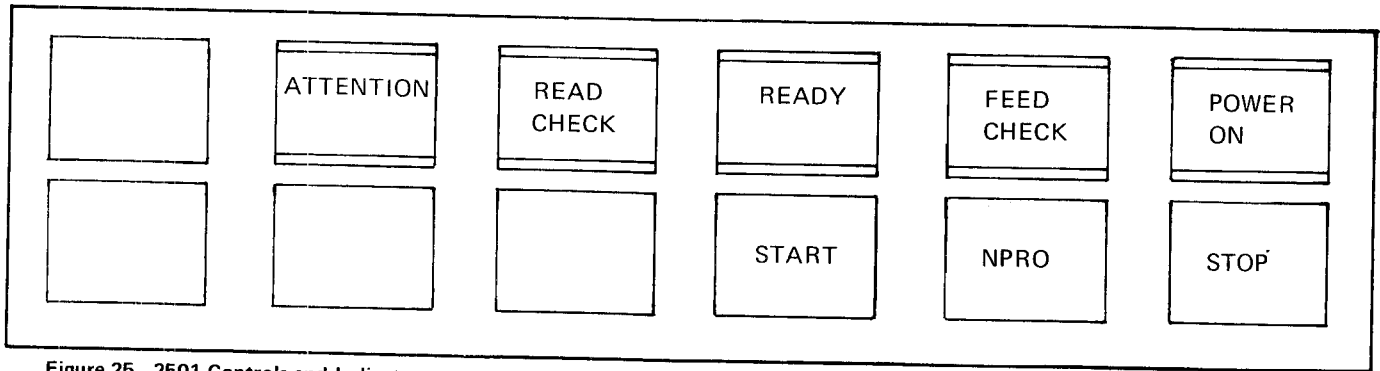

Figure 25. 2501 Controls and Indicators

**FEED CHECK:** The following conditions exist:

1. A card is mispositioned in the card path. To turn off this light, follow the procedure for clearing a card jam given later in this chapter.
2. System power is turned on. To turn off this light, follow the *Power On and Ready Procedure*.

**POWER ON:** Power is being supplied to the 2501 from the system.

### Control Keys

**START:** Press this key to place the 2501 in the ready state. The READY light turns on if all the conditions listed for the ready state are met. If no card is at the preread station, one card is fed to that position.

**NPRO (Nonprocess Runout):** Press this key to clear all cards from the card path without reading them. Before the NPRO key can function, any card jam must be removed and the hopper must be empty.

**STOP:** Press this key to stop the 2501 and remove it from the ready state. If a card operation is in progress, it is completed before the machine stops.

### Usage Meter

The 2501 usage meter records time from the time the first 2501 command is received until the time that runout is complete. Runout is accomplished by pressing the NPRO key.

### POWER ON AND READY PROCEDURE

1. Turn on the system POWER switch on the system control panel. The FEED CHECK light turns on.
2. Press NPRO to clear cards from the card path and turn off the FEED CHECK light.
3. Load cards into the hopper 9-edge first, face down.
4. Press START. The 2501 is now ready for operation.

### LAST CARD PROCEDURES

When the last card is fed from the hopper, the READY indicator turns off and a message is displayed on the CRT screen. If more cards are to be processed:

1. Load more cards into the hopper.
2. Press START to continue operation.

If no more cards are to be processed, press START. This returns the 2501 to its ready state and allows the last card to be read.

## CLEARING A CARD JAM

1. Remove cards from the hopper.
2. Open the machine cover.

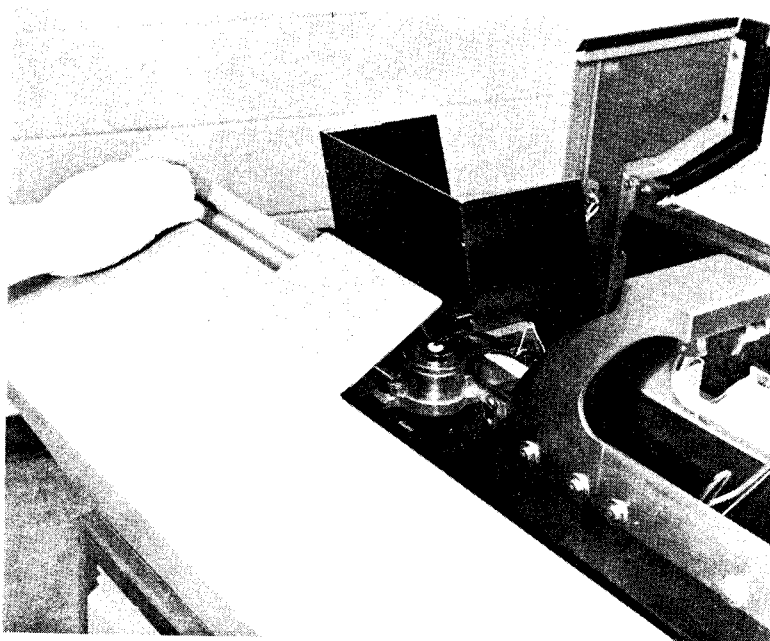

3. Remove the jammed card. If you cannot free the card, it may be jammed under a feed roller or in the preread station.

4. If the card is jammed under a feed roller, turn the hand wheel to free the card.

5. If the card is jammed in the preread station, lift up the plastic card guide and remove the card. Then lower the card guide back into position.

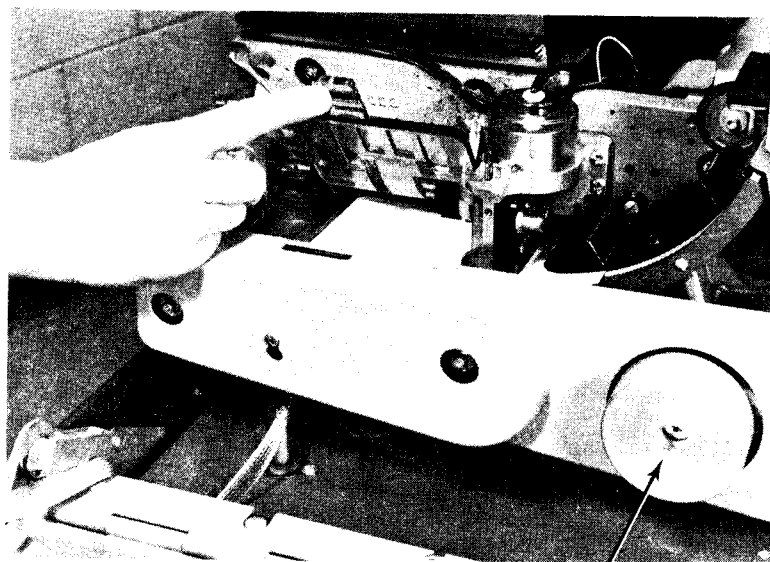

Hand Wheel

6. Close the cover.
7. Press NPRO.
8. Replace cards in the hopper.
9. Press START.

- Controls and Indicators
- Loading the Carriage Control Tape
- Loading Forms
- Changing the Printer Ribbon
- Changing the Print-Chain Cartridge
- Controlling Print Quality

1403 Printer

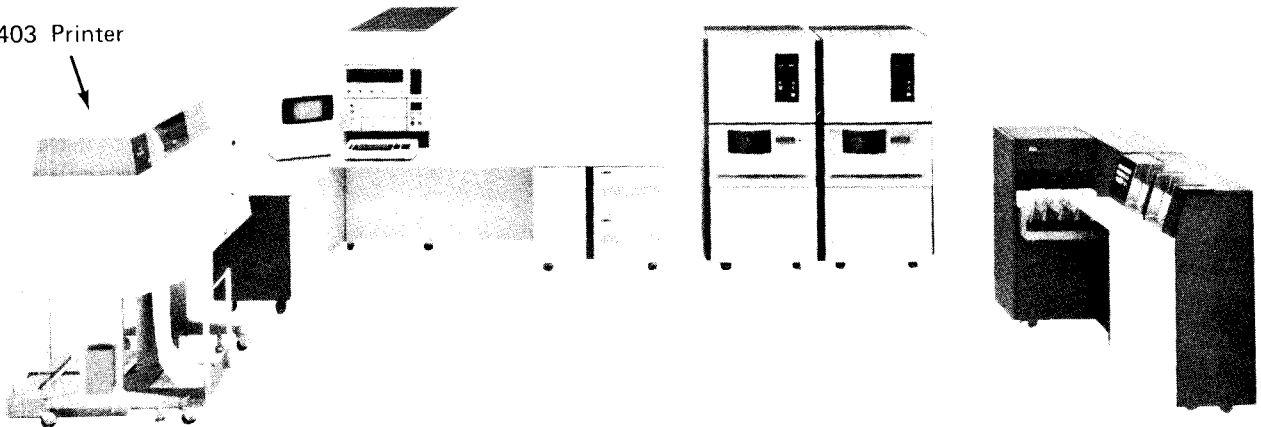

## CONTROLS AND INDICATORS

The operating controls and indicator lights for the IBM 1403 Printer are in the upper left corner on the front of the machine.

### Indicator Lights

The 1403 has two groups of indicator lights. One group is located on the operator's panel; the second group is located under the front cover, below the feed clutch control.

#### Operator Panel Lights

The operator panel lights (Figure 26) indicate the following:

**PRINT READY:** The printer is ready to accept commands from the processing unit. This light turns off when:

- The STOP key is pressed.
- The END OF FORMS indicator turns on.
- An error condition exists (such as FORMS CHECK, SYNC CHECK, or PRINT CHECK light on).

**PRINT CHECK:** A malfunction has occurred in the printer. To turn off this indicator, press CHECK RESET and then START. If the light turns on again, repeat the procedure.

### CAUTION

If the light comes on a third time, there is probably a hardware problem that could cause serious damage if you continue to try the reset procedure. Call IBM for hardware support.

**END OF FORMS:** The printer has run out of forms. The printer stops. The page currently being printed may not have been completed.

If the end-of-forms condition occurs during a skip or space operation, press the SINGLE CYCLE key to print each line remaining on the page.

To turn off the END OF FORMS light, insert new forms as explained in *Loading Forms* later in this chapter.

**FORMS CHECK:** One of the following conditions has occurred:

- Forms are not feeding properly through the forms tractor.
- Forms guide platen is open.
- Carriage control tape is not installed.
- Carriage brush assembly is open.
- Feed-clutch manual control is not properly positioned.

To turn off the FORMS CHECK light, follow the procedures for correcting the condition.

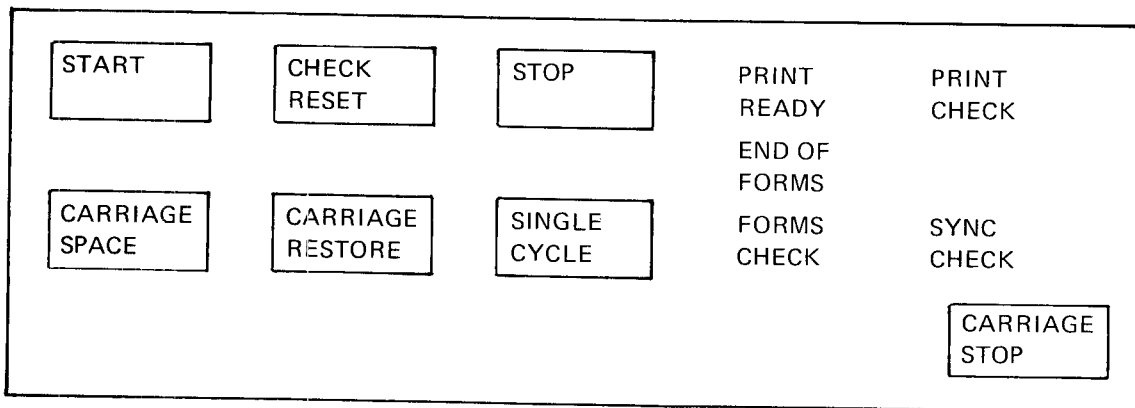

Figure 26. Operator Panel Keys and Lights, 1403 Models 2 and 5



**SYNC CHECK:** The print chain is not synchronized with the compare circuits in the printer. This usually is caused by an incorrect print chain speed. SYNC CHECK can also be turned on by incorrectly positioning the forms cart so that it is not in contact with the ground springs on the printer. To restart, check the position of the forms cart, then press CHECK RESET and START.

#### *Indicator Panel Lights*

The indicator panel lights are behind the front cover of the printer and below the manual feed clutch control. They indicate the following:

**GATE INLK:** The print unit is not in position. To turn this light off, lock the print unit in position with the print-unit release lever.

**BRUSH INLK:** The carriage tape brushes are not latched in position. Lock the brushes in place (see *Loading the Carriage Control Tape*).

**SHIFT INLK:** The manual feed clutch control is not positioned properly. Set the feed clutch to either six or eight lines-per-inch spacing.

**THER INLK:** A thermal interlock has occurred. (A fuse has burned out and service is required.) Call IBM for hardware support.

**HS START:** A high-speed skip operation has begun.

**LS START:** A low-speed skip or line spacing operation has begun.

**HS STOP:** A high-speed-skip stop operation has begun or the carriage is not in motion.

**LS STOP:** A low-speed-skip stop operation has begun or the carriage is not in motion.

#### **Printing Control Keys**

The control keys are shown in Figure 26.

**START:** Press this key to put the printer in the ready state provided the following conditions are met:

- System power is on.
- No error conditions exist (such as PRINT CHECK, SYNC CHECK, or FORMS CHECK light on).

START is also used to finish printing a page after the END OF FORMS indicator turns on.

A START key is also located on the back of the machine for your convenience. This key operates exactly as the one on the front of the machine.

**CHECK RESET:** Press this key to reset a printer error indicator. After pressing CHECK RESET, you must press START to restart the operation.

**STOP:** Press this key to stop the printer and remove it from the ready state. If a print operation is in progress when STOP is pressed, the operation is completed before the printer stops.

A STOP key is also located on the back of the machine for your convenience. This key operates exactly as the one on the front of the machine.

#### **Carriage Control Keys**

**CARRIAGE SPACE:** Press this key to advance the form in the printer one line space if the feed clutch is engaged.

**CARRIAGE RESTORE:** Press this key to advance the form in the printer to the first line on the next page. If the carriage feed clutch is disengaged, the form does not move. You must press START to restart the operation.

**Note:** This key must not be pressed while the printer is printing because the results are unpredictable and carriage runaway may occur. You should press STOP before you press CARRIAGE RESTORE.

**SINGLE CYCLE:** Press this key to print one line. You must press the START key to return the printer to normal operation. If an end-of-form condition exists, you can continue to print one line at a time by pressing SINGLE CYCLE until the end of the form is reached. If the unit record restart function has been specified at system generation time, using this key provides a convenient method for aligning forms.

### Usage Meter

For printers, the meter-initiating condition will be the first write instruction from the CPU to the printer. The stopping condition will be when any manual carriage operation occurs. This operation will be a manual eject or a manual space key operation.

### Manual Controls

This discussion describes the controls located inside the machine covers that you use to adjust the printer to suit your printing needs. Figure 27 shows the machine with the cover open.

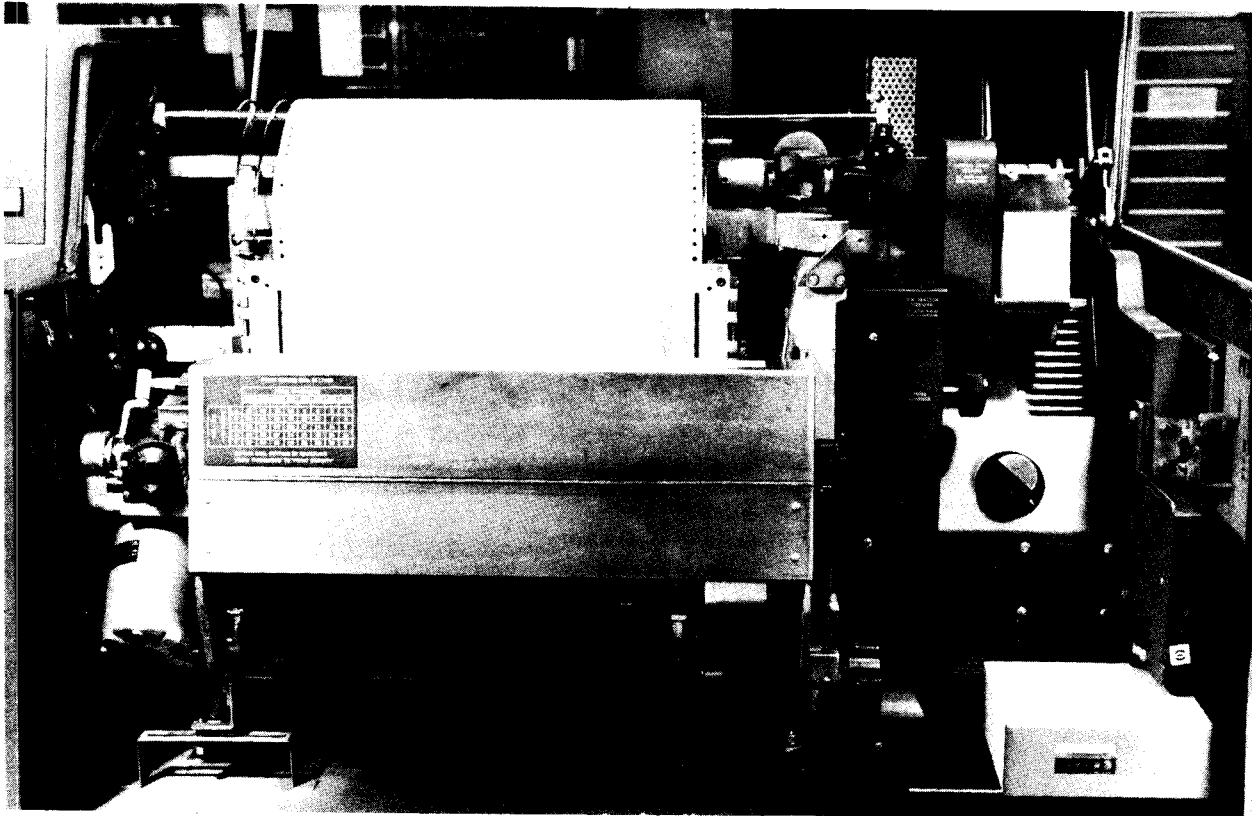
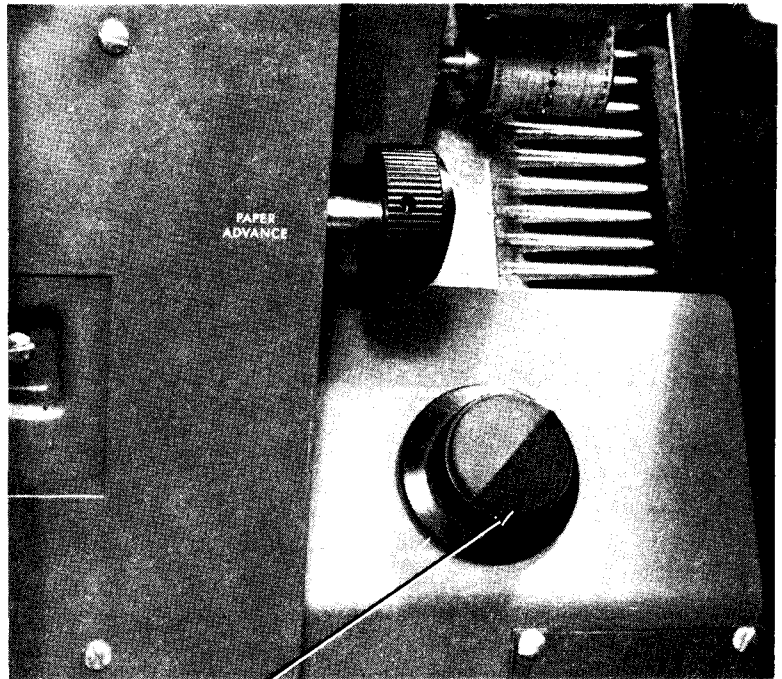

Figure 27. 1403 With Cover Open

*Paper Advance Knob:* This knob positions the form vertically, line by line. When the paper advance knob is used, the feed clutch must be set to neutral. If you use this control to change the position of the form in the printer, the change is not recorded by the system. Therefore, if you advance a page from line 2 to line 4, when printing continues the system continues as though you had not changed lines. You must use the **CARRIAGE SPACE** key to advance the form if you want the line spaces recorded by the system.

*Feed Clutch Control Knob:* This knob controls the carriage tape drive and form feeding mechanism. You can select either six or eight lines-per-inch spacing. When this knob is set at neutral, automatic form-feeding cannot occur.



Feed  
Clutch

*Print-Unit Release:* This control unlocks the print unit. The print unit can then be swung open to provide access to the transport area.

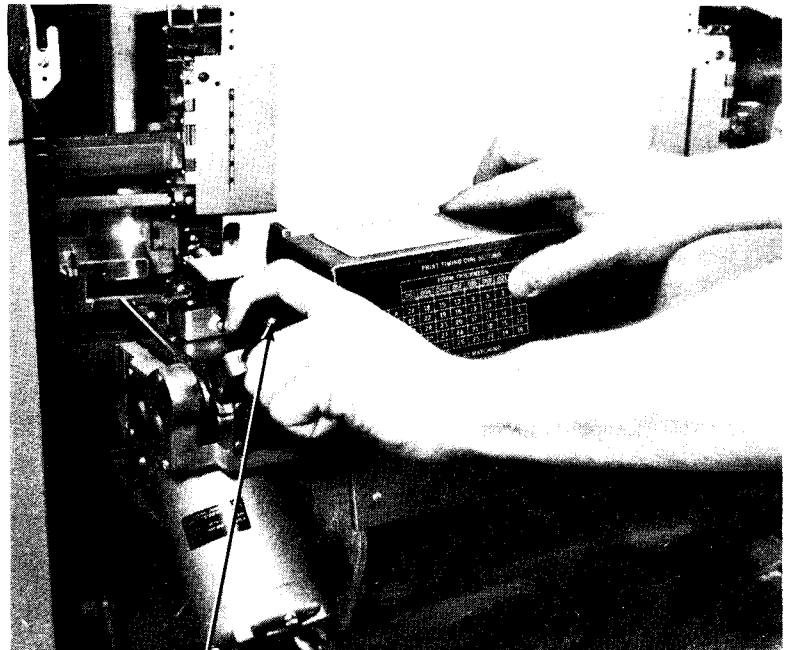

Print-Unit  
Release  
Lever

*Print-Line Indicator and Ribbon Shield:* This assembly swings open with the ribbon mechanism when the print unit is swung open. This assembly can also be opened independently of the print unit.

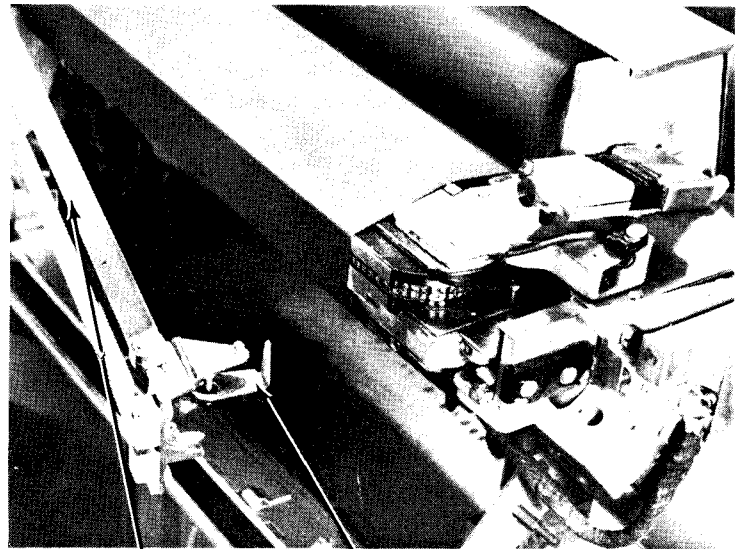

Print Line Indicator

Latch

*Vertical Print Adjustment Knob:* This knob controls the fine spacing adjustment of forms at the print line. When you adjust the line positioning with this knob, the line number at the print line is not affected.

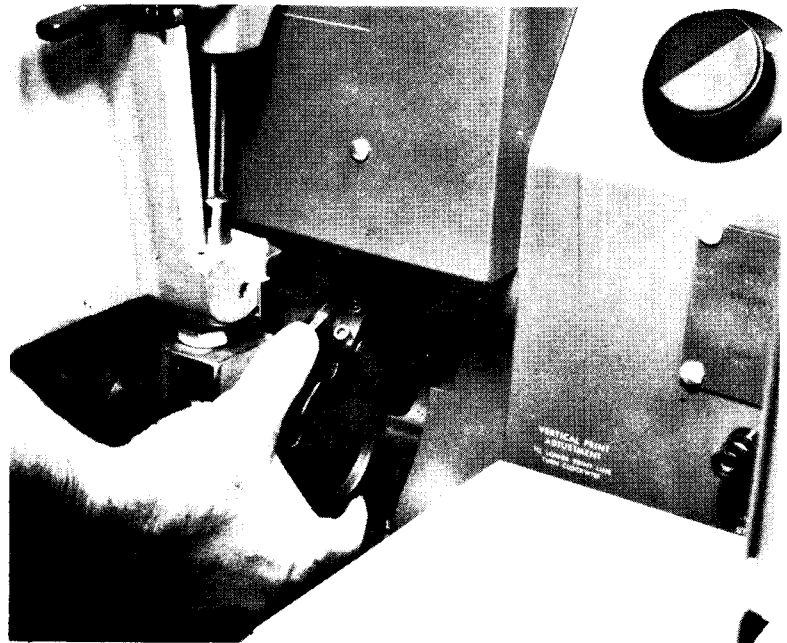

*Lateral Print Adjustment Lever:* This lever allows horizontal positioning of the print mechanism. When you raise the lever, the print mechanism is unlocked and can be positioned horizontally; when you lower the lever, it locks the print mechanism in the new position. The amount of horizontal positioning is limited by the positions of the forms tractors.

*Lateral Print Vernier Knob:* This knob fine adjusts the horizontal position of the print mechanism. Before you use this knob, the lateral print adjustment lever must be in the lowered (locked) position.

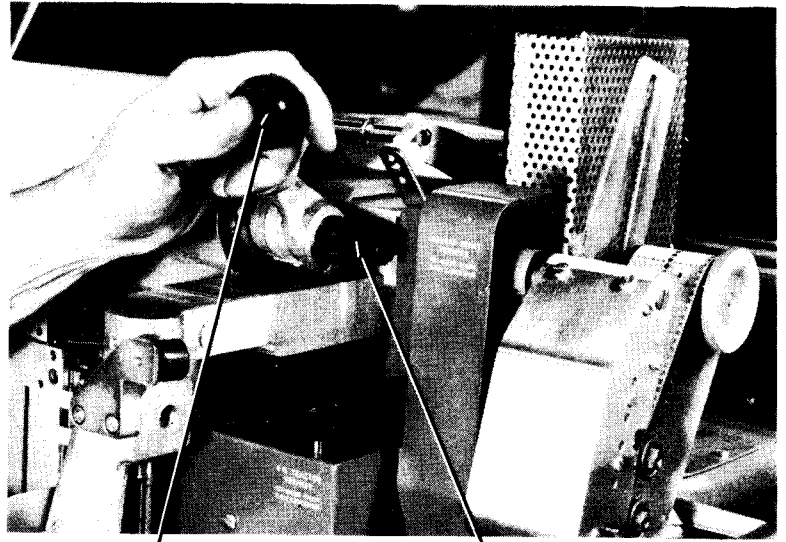

Lateral Print Adjustment Lever

Vernier Knob

*Tractor Slide Bars (Figure 28):* These bars allow positioning of the forms tractors to accommodate different width forms. The forms tractors are mounted on the upper and lower slide bars. Notches are provided in the tractor slide bars to hold the forms tractors in position. The left tractor moves to fit the form width and is locked in position by a spring loaded latch (Figure 28). Normally, the left tractor is located in the third notch from the left.

The form widths associated with the most-used notches are:

- First notch – 5-1/2 to 18-3/4 inches (140 to 476 mm)
- Second notch – 4-1/2 to 17-3/4 inches (114 to 451 mm)
- Third notch – 3-1/2 to 16-3/4 inches (89 to 425 mm)
- Ninth notch – 3-1/2 to 10-3/4 inches (89 to 273 mm)

The right-hand tractor is locked into place by spring locked pins snapped into any of 27 holes located on the tractor slide bar.

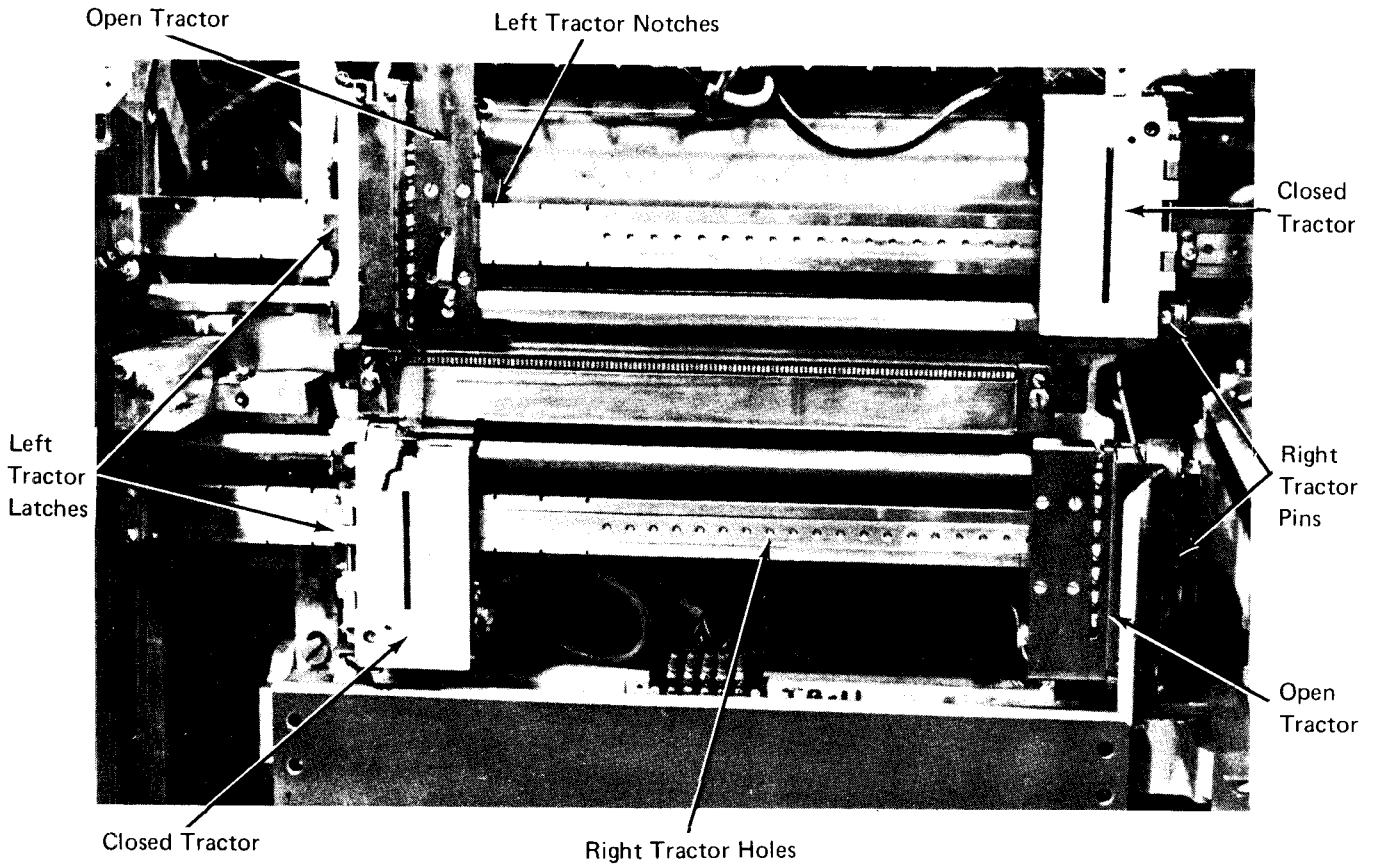
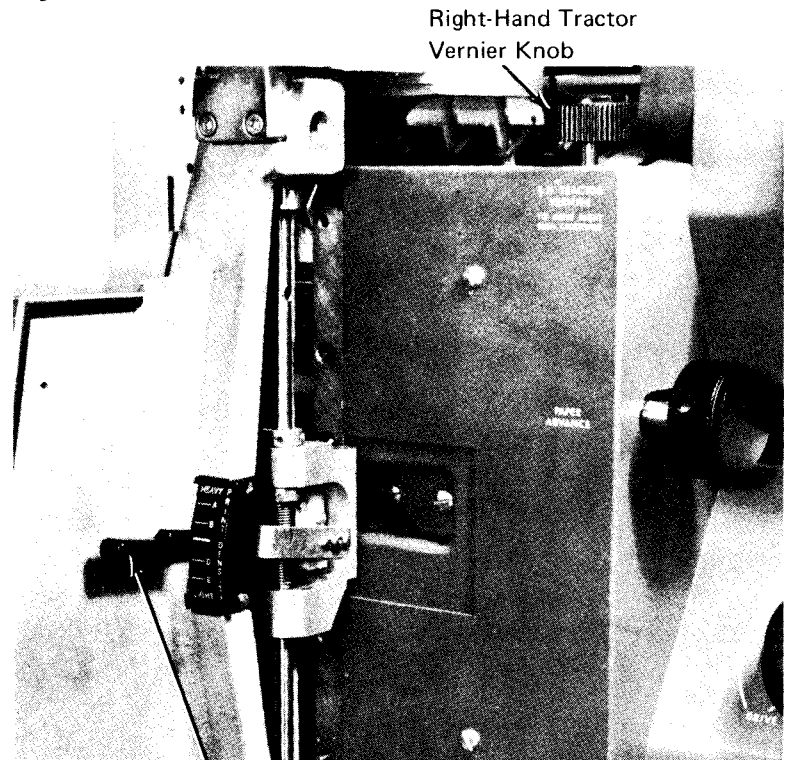

Figure 28. Tractor Slide Bars

*Right-Hand Tractor Vernier Knob:* This knob controls the fine adjustment in paper tension, keeping the paper tight horizontally.

*Print Density Lever:* This lever controls the print impression to accommodate various thicknesses of forms. When the lever is set at A, the print impression is the darkest; when set at E, printing is the lightest. C is the normal setting.



Print  
Density  
Lever

*Print Timing Dial:* This dial fine-adjusts print quality. The proper dial setting is obtained from the print-timing dial chart on the ribbon cover. The print density lever setting and the thickness of the form determine the correct dial setting.

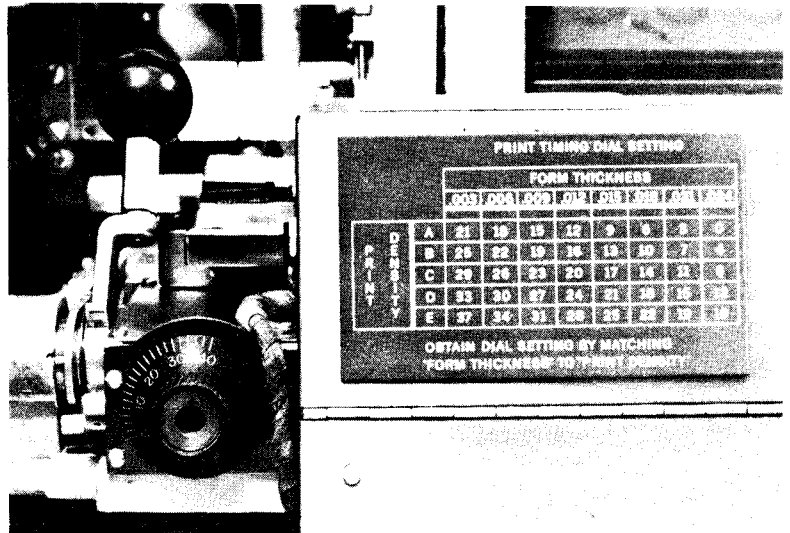

## LOADING THE CARRIAGE CONTROL TAPE

A standard prepunched carriage control tape is provided with the machine. This tape is long-lasting and requires no attention other than infrequent inspection for wear. The part number for this prepunched tape is 428470. To load the carriage control tape, perform the following procedure:

1. Raise the printer cover.
2. Turn the feed clutch to neutral.
3. Press the latch on the side of the brush holder, and raise the assembly.
4. With the printing on the outside of the tape loop, place the tape over the pin-feed drive wheel so that the pins engage in the holes in the tape. Make sure that the line position numbers are on the right side of the tape loop, as seen from the front of the printer.
5. Place the other end of the tape loop around the adjustable carriage-control tape idler.

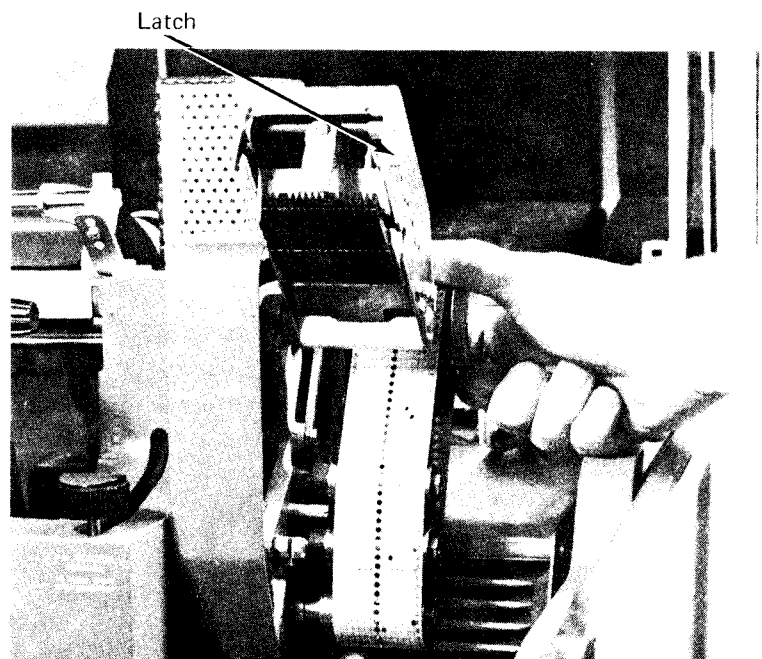

6. Adjust the idler by loosening the locking knob and moving the idler in its track. There should be no noticeable slack in the tape, nor should the tape be under tension. Test the tape by pressing the sides of the loop together; there should be some give. If the tape is too tight, the pin holes will be damaged. Retighten the idler locking knob.
7. Lower the brush assembly. A click can be heard when the latch engages.
8. Press CARRIAGE RESTORE. When the tape has returned to home position (line count 1), engage the feed clutch.
9. Close the printer cover.
9. Tighten tension on the form, using the right-hand tractor vernier. The paper has the correct tension when it lies flat across the printing area and the tractor pins are centered in the pin holes.
10. Position the form by turning the paper advance knob until the line, block, or area on which the first line is to be printed is just visible above the ribbon guide bar.
11. Align the desired hammer position (print position) to the form with the lateral print alignment lever and vernier. Note the relationship of the form to the markings on the ribbon guide bar to determine the correct position.

12. Turn the paper advance knob backward three line positions if you are printing six lines per inch (25.4 mm) or four line positions if you are printing eight lines per inch (25.4 mm). The form is now properly positioned.

#### LOADING FORMS

1. Raise the printer cover.
2. Turn the feed clutch to neutral.
3. Unlock the print unit release lever and swing back the print unit.
4. Set both the left-hand forms tractors slightly to the left of the first print position. Move the tractor to the left until it latches in the appropriate notch.
5. Open the left-hand tractor covers and place the forms over the tractor pins. Close the covers.
6. Open both right-hand tractor covers.
7. Pull out the tractor pin-latch and slide the right-hand tractors into the location where they line up with the right side of the forms. Slide the tractors so that the pin-latch snaps into the appropriate position.
8. Place the forms over the right-hand tractor feed-pins and close the tractor covers.
13. Close and lock the print unit. Be sure to push the print-unit release lever as far back as possible.
14. Press CARRIAGE RESTORE to return the carriage control tape to home position (line count 1).
15. Set the feed clutch for either six or eight lines per inch (25.4 mm).
16. Close the printer cover.
17. Position the paper supply so the forms feed straight up into the machine.
18. When printing begins, guide the first form between the forms stacker guide and the machine. Adjust the first few forms in the stacker so that they fold flat.



Forms stacking is automatic as the paper is fed out of the machine. A set of circular flat springs maintains paper tension as the paper is fed through the stacker. These springs can be disengaged by a pair of lift bars. To disengage the springs, pull the bars out of the locked position and place them on top of the plastic bar locks. This allows gravity stacking.

A paper guide helps feed the forms into the stacking area so that they fold flat. The paper guide (which includes the circular flat springs) can be raised and lowered by using the paper guide control knob. As the forms stack gets higher, raise the paper guide.

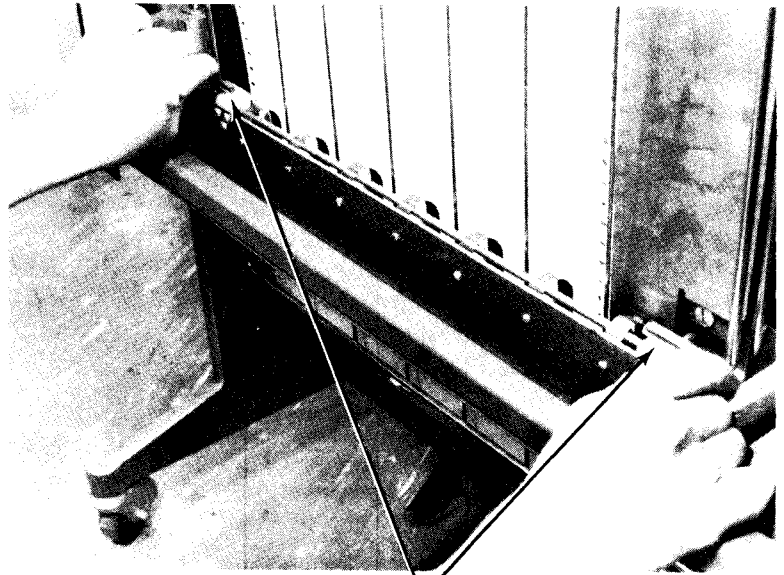

Plastic Bar Lock

### CHANGING THE PRINTER RIBBON

1. Raise the printer cover.
2. Pull back the print-unit release lever. Swing out the print unit.
3. Open the top ribbon cover.
4. Unlatch the print-line indicator ribbon shield and swing it away from the ribbon.

*Note:* If plastic gloves are provided with the ribbon, put them on at this time.

5. Push the top ribbon roll to the right (the hinged side of the print unit). Lift out the left end of the roll and remove the roll from the drive end of the mechanism.
6. Slip the ribbon from under the ribbon correction roller.
7. Remove the bottom ribbon roll by pushing the roll to the right, lowering the left end of the roll, and removing it.

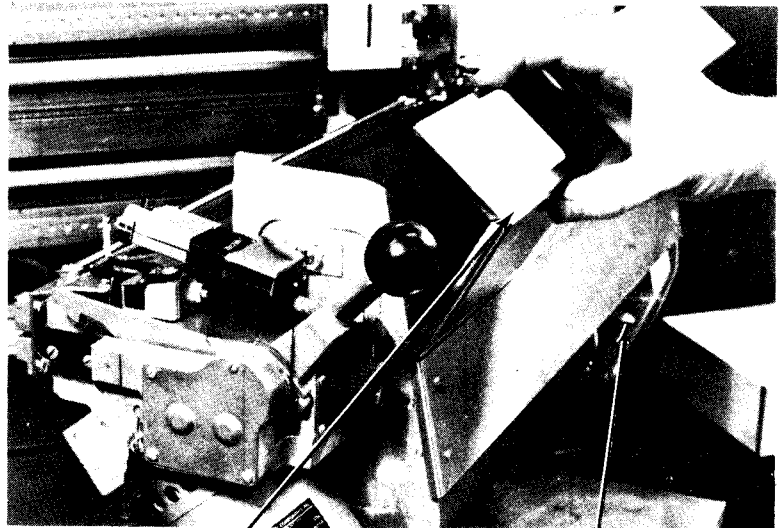

Top Ribbon Cover

Ribbon Width Lever

8. Place the new ribbon spool on the bottom spindle. The new ribbon should be installed as shown in the diagram.
9. Place the right end of the new spool in place on the bottom spindle. Push the spool to the right and put the left end on the spindle.
10. Put the ribbon in place as shown.
11. Slide the ribbon under the ribbon correction roller.
12. Place the right end of the top spool in place on the top spindle. Push the spool to the right and put the left end on the spindle.
13. Set the ribbon width lever to correspond to the width of the ribbon.
14. Hand-tighten the ribbon to remove any slack from in front of the printing mechanism.
15. Close the top ribbon cover.
16. Close and lock the print unit. Be sure to push the print-unit release lever as far back as possible.
17. Close the printer cover.

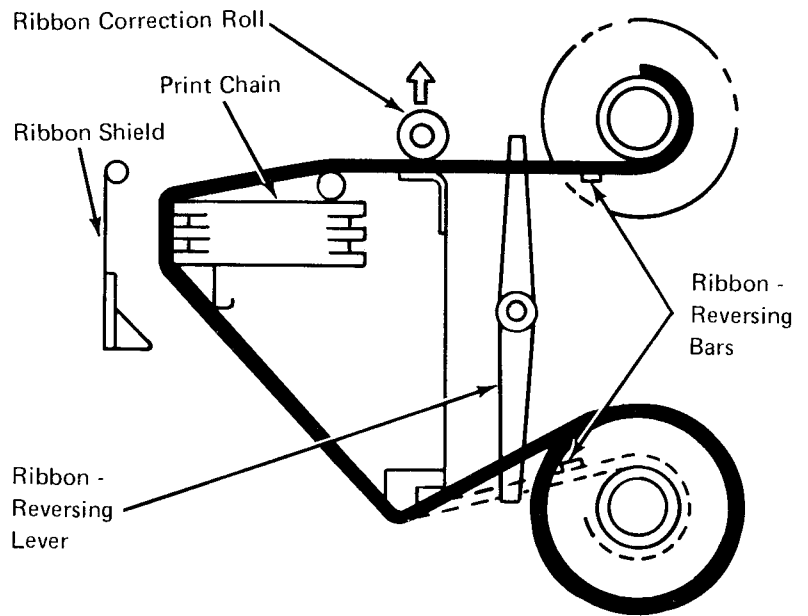

#### CHANGING THE PRINT-CHAIN CARTRIDGE

1. Raise the printer cover.
2. Pull back the print-unit release lever. Swing out the print unit.
3. Open the top ribbon cover.
4. Unlock the print-line indicator and swing it against the form.

5. Remove the bottom ribbon spool, as described under *Changing the Printer Ribbon*, and place it on the open top ribbon cover.



6. Unplug the electrical connection between the cartridge and the printer. (This applies to Universal Character Set cartridges only.)

7. Pivot the two handles on top of the cartridge to their vertical positions. The cartridge is now unlocked and can be lifted out of the print unit by the handles.

8. Lift the new cartridge by the handles and lower it evenly into position on the aligning pins.

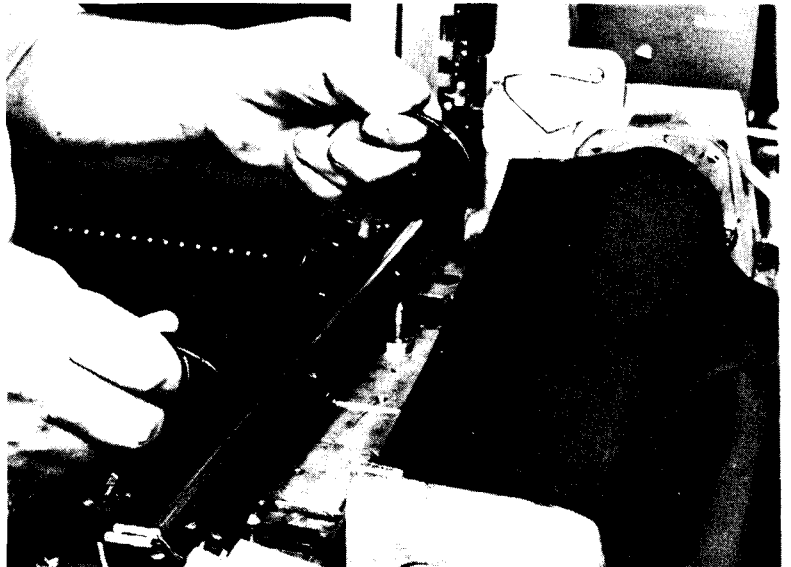

9. If the left end of the cartridge does not seat fully (the aligning pins are not flush with the top of the cartridge), perform the following:
  - a. Hold down the idler gear brake button in the chain drive gear cover.
  - b. Manually rotate the chain counter-clockwise until the driving key in the timing disk is aligned with the slot in the chain drive sprocket.

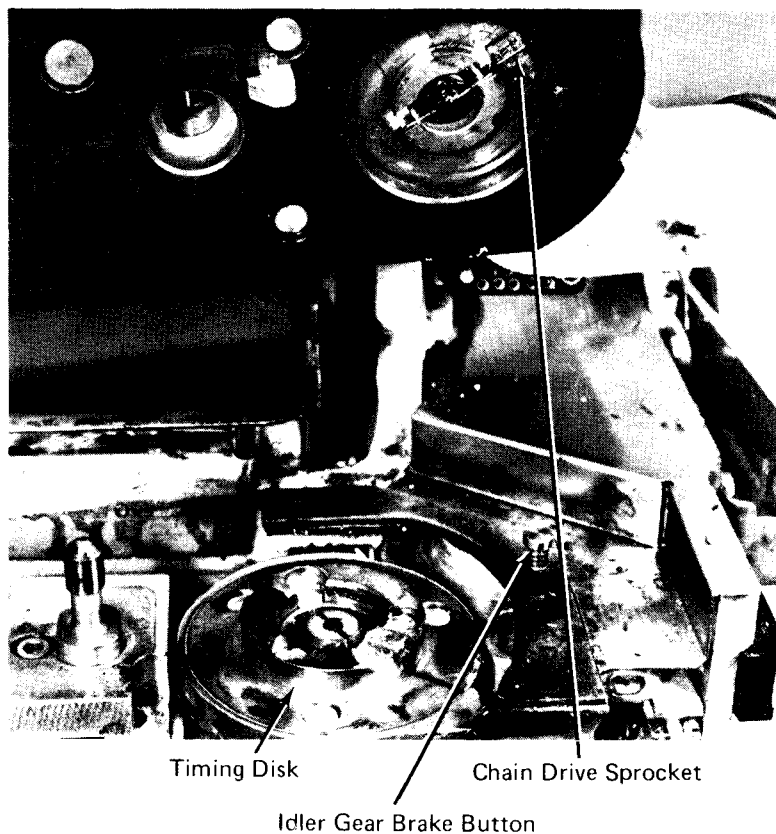

10. Press down lightly on the handles to lock the cartridge in position. If the cartridge does not lock, repeat step 8.
11. Plug the electrical connection from the cartridge into the connection on the point unit. (This applies to Universal Character Set cartridges only.)
12. Replace the ribbon spool, as described under *Changing the Printer Ribbon*.
13. Close and lock the print unit. Be sure to push the print-unit release lever as far back as possible.
14. Close the printer cover.

## CONTROLLING PRINT QUALITY

Your printer applications often require adherence to strict print-quality requirements, such as when the printer output must be used as input for optical character recognition (OCR) devices. You then must take certain precautions to ensure acceptable print quality. These include:

1. Using recommended ribbon and paper-weight combinations (usually specified on the job setup sheet).
2. Supervising and adjusting print density as required.
3. Replacing the ribbon as required (see *Changing the Printer Ribbon*).
4. Cleaning the type faces.

### Print-Density and Forms-Thickness Adjustments

In applications where print quality is critical, correct print-density and forms-thickness adjustments are important. The forms-thickness adjustment must correspond to the thickness of the forms used. If the thickness cannot be measured directly, obtain this information from the supplier. The forms tractors must be adjusted so that the forms are as tight as possible without tearing or bursting the forms (see *Loading Forms*).

Because each printing format causes unique ribbon wear, you should monitor and adjust the print-density during a job to ensure even print quality throughout the application. You can correct print-density conditions as follows:

1. Adjust the print-density control lever to get the best impression possible for the forms being used.
2. Set the print-timing dial for the forms thickness as prescribed by the chart on the print unit. If the left edges of the characters are cut off as shown, turn the print-timing dial counterclockwise until they reappear. If the right edges are cut off, turn the dial clockwise.

 Cutoff (left)

 Cutoff (right)

If these adjustments do not correct the problem, call IBM for hardware support.

## Type-Face Cleaning

For best results, you should clean the type faces periodically; first with a vacuum cleaner, then with type-cleaning paper (such as IBM part 451529 or its equivalent). Type-cleaning paper is a crepe-like paper with a tacky surface. Dirt from the type adheres to its surface.

**Note:** Under no circumstances should the print chain be cleaned by any other method.

1. Open the printer cover.
  2. Open the print unit and remove the ribbon.
  3. Remove the forms.
  4. Vacuum the cartridge, type faces, and print areas.
  5. Install the type-cleaning paper on the tractors, just as you would any other form. Make sure the crepe side is facing you.
  6. Position the paper and tractors so that the entire print area is between the perforated margins.
  7. Close and lock the print unit.
  8. Set the print-density control to C and the print-timing dial to 17.
  9. Put the feed clutch in neutral and press CHECK RESET. This turns off the FORMS CHECK indicator.
  10. Leave the printer cover open and load a program that will print all the characters on the chain. Press START.
  11. Using the paper advance knob, manually space the paper every five or six lines until the type faces are clean. The type faces are clean when a very light line is printed.
- Note:** Avoid printing more than ten print lines before advancing the paper, because the crepe surface may shred. Shreds may lodge between the type slugs and cause serious damage to the print chain.
12. Remove and discard the cleaning paper.
  13. Reinstall the ribbon and forms.
  14. Close the printer cover.



- Controls and Indicators
- Loading the Carriage Control Tape
- Loading Forms
- Changing the Printer Ribbon
- Changing the Print-Train Cartridge
- Controlling Print Quality

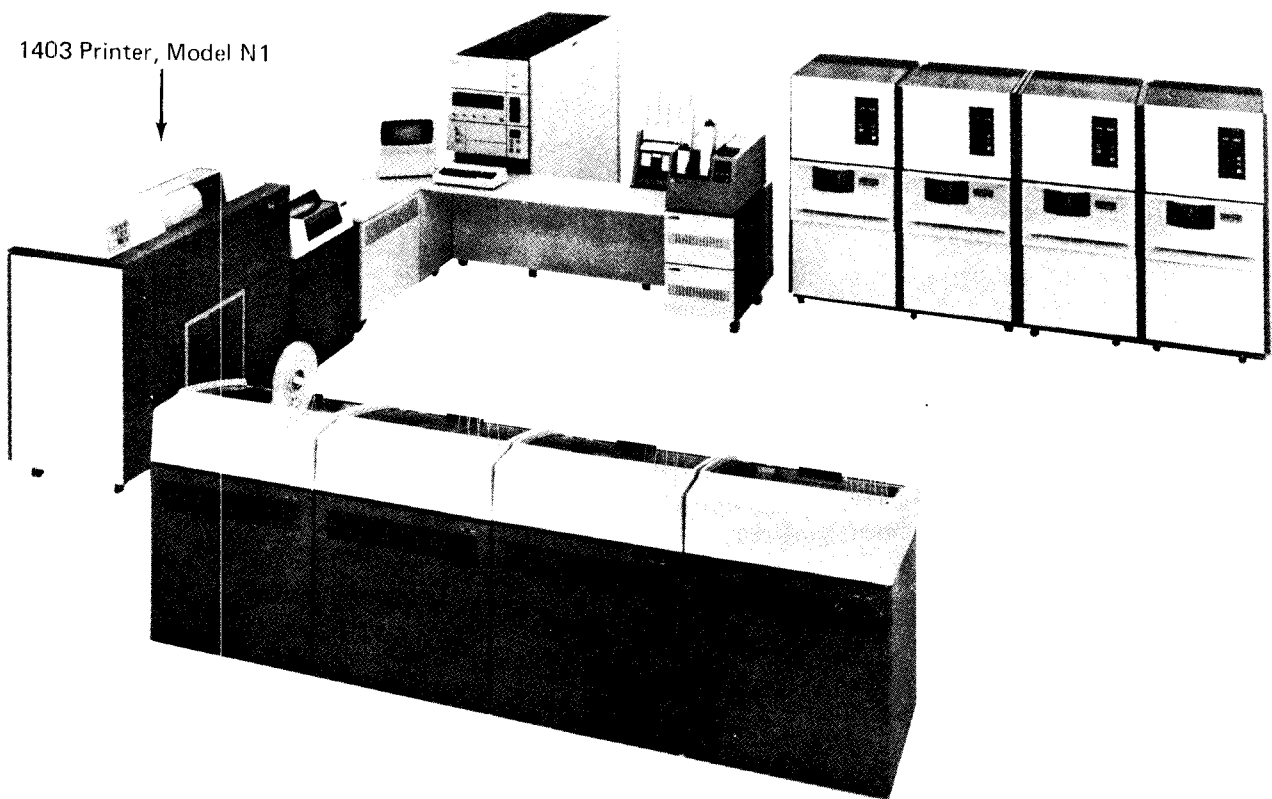

## CONTROLS AND INDICATORS

The operating controls and indicator lights for the IBM 1403 Printer are in the upper left corner on the front of the machine.

### Printer and Carriage Control Keys

The control keys are shown in Figure 29.

**SINGLE CYCLE:** Press this key to print one line. After using this key, press **START** to return the printer to normal operation. If an end-of-form condition exists, you can continue to print the page one line at a time by pressing the **SINGLE CYCLE** key until the end of the page is reached. If the unit record restart function has been specified at system generation time, using this key provides a convenient method for aligning forms.

**COVER LOWER:** Press this key to close the printer cover. You need not hold the key down until the cover is closed. If you press the **COVER RAISE** key while the cover is descending, the cover returns to a fully raised position.

**COVER RAISE:** Press this key to open the printer cover. You need not hold the key down until the cover is raised. If you press the **COVER RAISE** key while the cover is descending, the cover returns to a fully raised position.

**Note:** The cover rises automatically when a form check or end-of-form occurs. Therefore, do not place anything (extra forms, card decks, etc.) on the printer cover.

**CARRIAGE SPACE:** Press this key to advance the form in the printer one line space if the feed clutch is engaged.

**CHECK RESET:** Press this key to reset a printer error indicator such as print check or sync check. After pressing the **CHECK RESET** key, press **START** to restart the operation.

**CARRIAGE RESTORE:** Press this key to advance the form in the printer to the first line on the next form if the feed clutch is engaged. You must press **START** to restart the operation.

**Note:** This key must not be pressed while the printer is printing because the results are unpredictable and carriage runaway may occur. You should press **STOP** before you press **CARRIAGE RESTORE**.

**START:** Press this key to place the printer in the ready state provided the following conditions are met:

- System power is on.
- No error conditions exist (such as **PRINT CHECK**, **SYNC CHECK**, or **FORM CHECK** light on).

You can also use the **START** key to finish printing a page after the **END OF FORMS** indicator turns on.

A **START** key is also located on the back of the machine for your convenience. This key operates exactly as the one on the front of the machine.

**STOP:** Press this key to stop the printer and remove it from the ready state. If a print operation is in progress when the **STOP** key is pressed, the operation is completed before the printer stops.

A **STOP** key is also located on the back of the machine for your convenience. This key operates exactly as the one on the front.

**CARRIAGE STOP:** Press this key to stop the carriage operation and turn on the **FORM CHECK** light. After you press the **CARRIAGE STOP** key, the form may have to be realigned with the program. Press **CHECK RESET** to turn off the **FORM CHECK** light, then press **START** to restart the printer.



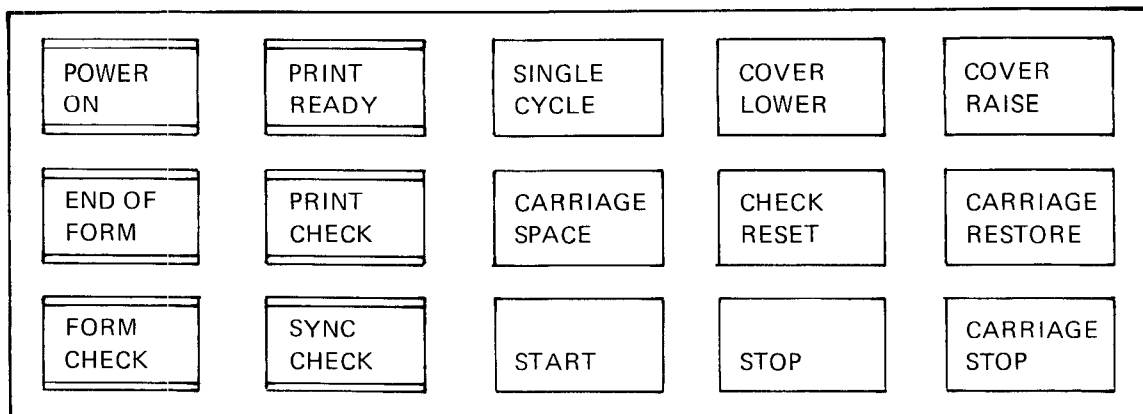

Figure 29. Operator Panel Keys and Lights, 1403 Model N1

### Indicator Lights

The 1403, Model N1, has two groups of indicator lights. One is on the operator's panel; the other is under the front cover, below the feed clutch control.

#### Operator Panel Lights

The operator panel lights (Figure 29) indicate the following:

**POWER ON:** The system power is on.

**PRINT READY:** The printer is ready to accept commands from the processing unit. This light turns off when:

- The STOP key is pressed.
- The END OF FORMS indicator turns on.
- An error condition exists (such as the FORM CHECK, SYNC CHECK, or PRINT CHECK light on).

**END OF FORM:** The printer has run out of forms. The printer stops at the next line 1.

You can press the SINGLE CYCLE key once for each line you want to print on the pages remaining on the form.

To turn off the END OF FORM indicator, insert new forms as explained under *Loading Forms* later in this chapter.

**PRINT CHECK:** A malfunction has occurred in the printer. To turn off this indicator, press CHECK RESET and then START. If the indicator turns on again, repeat the procedure.

#### CAUTION:

If the indicator comes on a third time, there is probably a hardware problem that could cause serious damage if you continue to try the reset procedure. Call IBM for hardware support.

**FORM CHECK:** One of the following conditions has occurred:

- Forms are not feeding properly through the forms tractor.
- Forms guide plates are open.
- Carriage control tape is not installed.
- Carriage brush assembly is open.
- Feed-clutch manual control is not properly positioned.

To turn off the FORMS CHECK light, follow the procedures for correcting the condition.

**SYNC CHECK:** The print train is not synchronized with the compare circuits in the printer. To restart, check the position of the forms cart and then press CHECK RESET and START.

### Indicator Panel Lights

The indicator panel lights are behind the front cover of the printer and below the manual feed clutch control. They indicate the following:

**GATE INLK:** The print unit is not in position. To turn off this light, lock the print unit in position with the print-unit release lever.

**BRUSH INLK:** The carriage tape brushes are not latched in position. Lock the brushes in place (see *Loading The Carriage Control Tape*).

**SHIFT INLK:** The manual feed clutch control is not positioned properly. Set the feed clutch to either six or eight lines-per-inch spacing.

**THER INLK:** A thermal interlock has occurred (a fuse has burned out and service is required). Call IBM for hardware support.

**HS START:** A high-speed skip operation has begun.

**LS START:** A low-speed skip or line spacing has begun.

**HS STOP:** A high-speed-skip stop operation has begun or the carriage is not in motion.

**LS STOP:** A low-speed-skip stop operation has begun or the carriage is not in motion.

### Usage Meter

For printers, the meter-initiating condition will be the first write instruction from the CPU to the printer. The stopping condition will be when any manual carriage operation occurs. This operation will be a manual eject or a manual space key operation.

### Manual Controls

This discussion describes the controls located inside the machine covers that you use to adjust the printer to suit your printing needs. Figure 30 shows the machine with the cover open and indicates where figures in the following discussion relate to the entire machine.

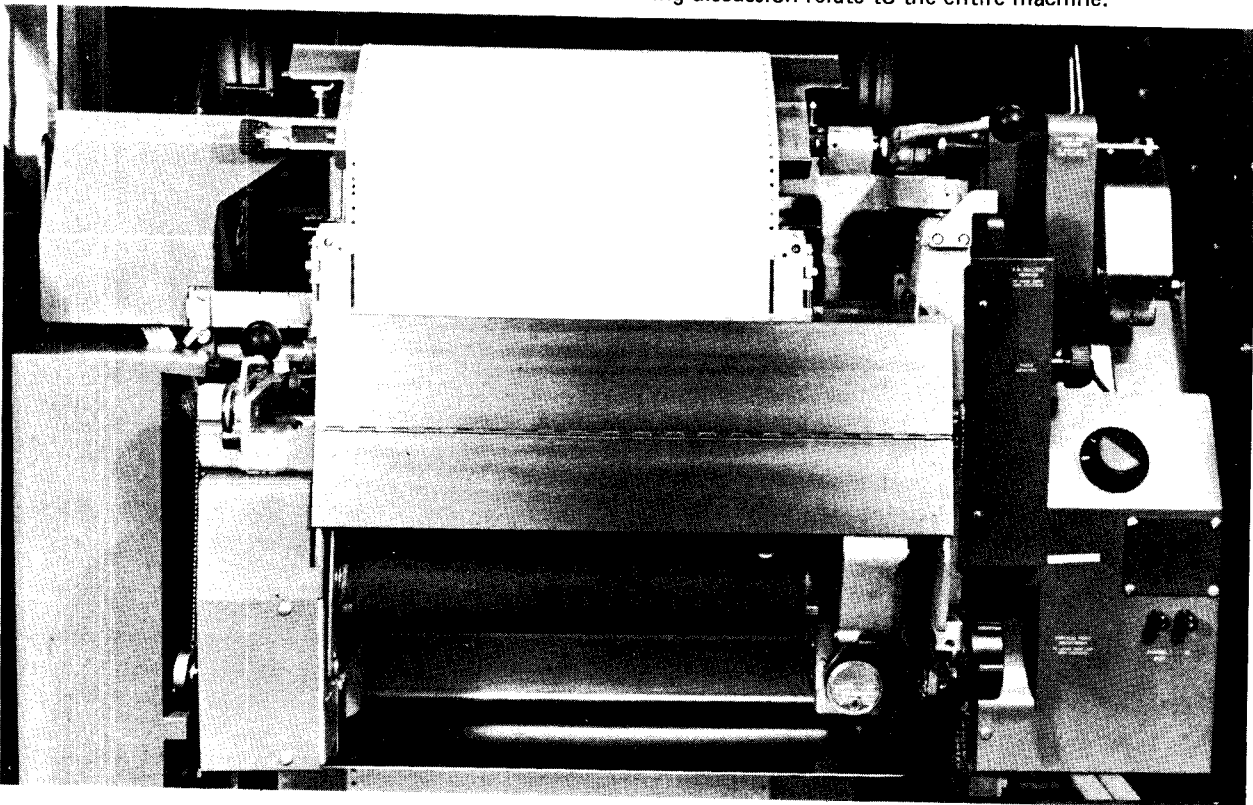
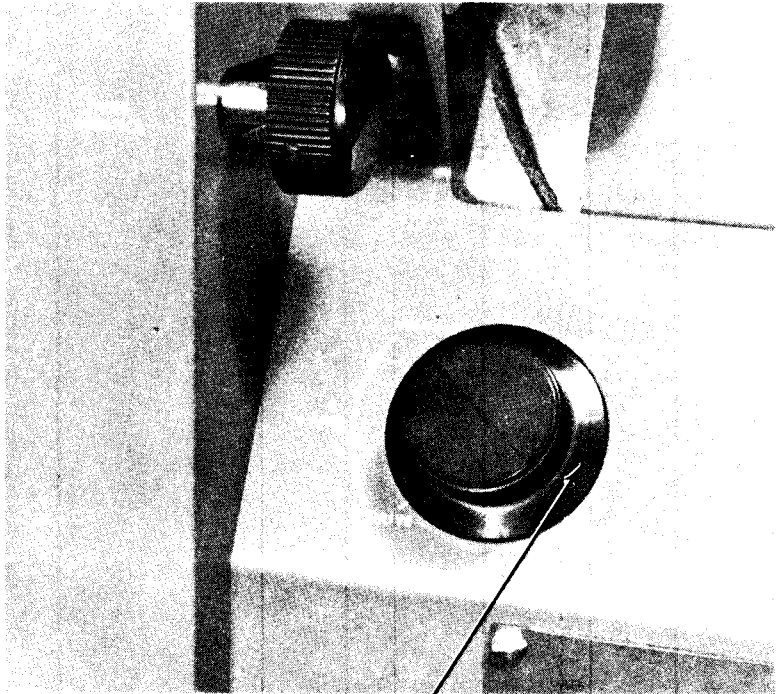

Figure 30. 1403, Model N1, With Cover Open

*Paper Advance Knob:* This knob positions the form vertically, line by line. When the paper advance knob is used, the feed clutch must be set to neutral. If you use this control to change the position of the form in the printer, the change is not recorded by the system. Therefore, if you advance a page from line 2 to line 4, when printing continues the system continues as though you had not changed lines. You must use the CARRIAGE SPACE key to advance the form if you want the line spaces recorded by the system.

*Feed Clutch Control Knob:* This knob controls the carriage tape drive and form feeding mechanism. You can select either six or eight lines-per-inch spacing. When this knob is set at neutral, automatic form-feeding cannot occur.



Feed Clutch

*Print-Unit Release Lever:* This lever unlocks the print unit as shown. The print unit can then be swung open to provide access to the transport area.

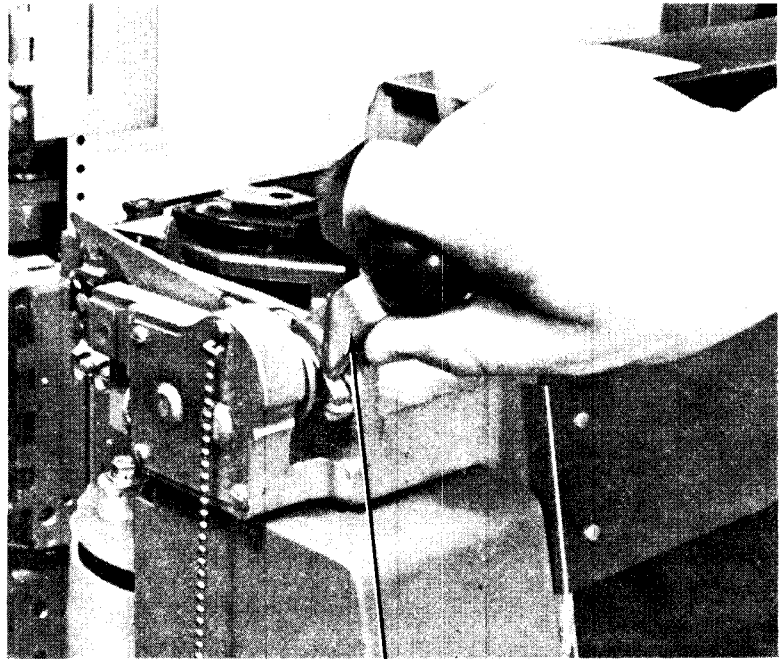

Print Unit Release Lever

*Print-Line Indicator and Ribbon Shield:* This assembly swings open with the ribbon mechanism when the print unit is swung open. This assembly can also be opened independently of the print unit.

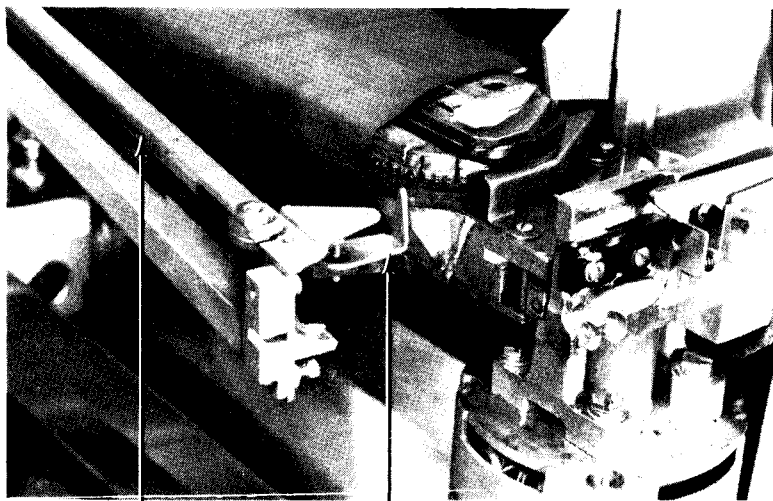

Print Line Indicator

Latch

*Vertical Print Adjustment Knob:* This knob controls the fine spacing adjustment of forms at the print line. When you adjust the line positioning with this knob, the line number at the print line is not affected.

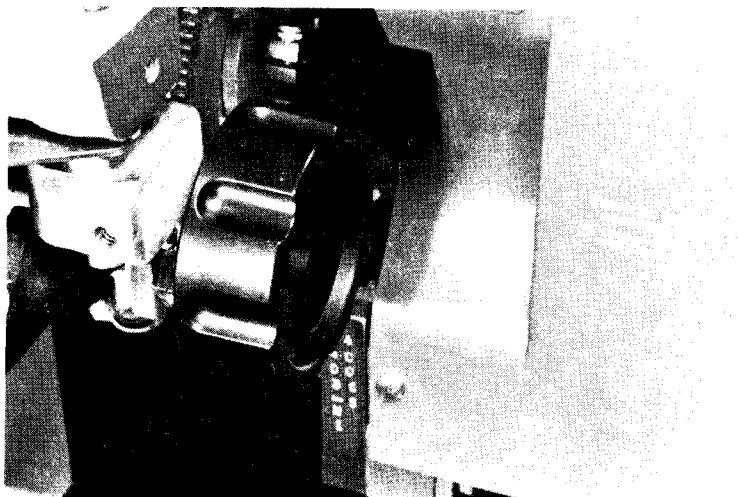

*Lateral Print Adjustment Lever:* This lever allows horizontal positioning of the print mechanism. When you raise the lever, the print mechanism is unlocked and can be positioned horizontally; when you lower the lever, it locks the print mechanism in the new position.

*Lateral Print Vernier Knob:* This knob fine adjusts the horizontal position of the print mechanism. Before you use this knob, the lateral print adjustment lever must be in the lowered (locked) position.

*Right-Hand Tractor Vernier Knob:* This knob controls the fine adjustment in paper tension, keeping the paper tight horizontally.

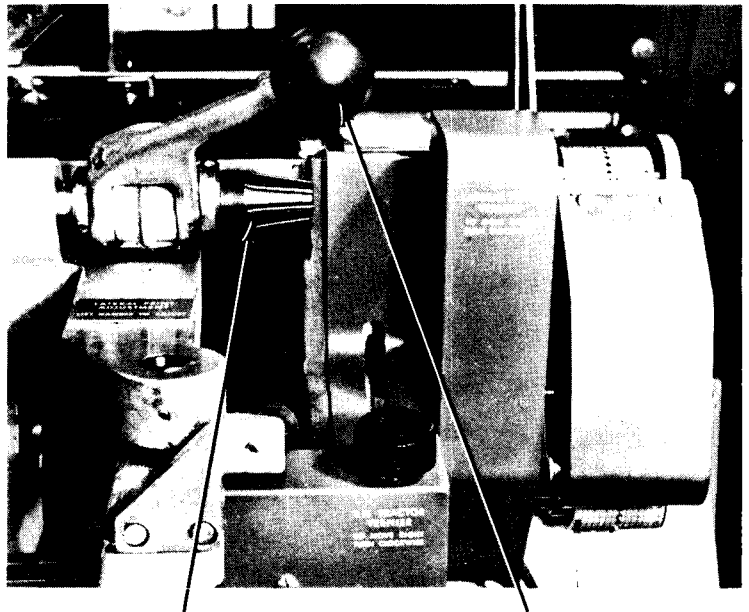

Vernier Knob

Lateral Print Adjustment Lever

**Tractor Slide Bars:** These bars allow positioning of the forms tractors to accommodate different width forms. The forms tractors are mounted on the upper and lower slide bars (Figure 31). Notches are provided in the tractor slide bars to hold the forms tractors in position. The left tractor moves to fit the form width and is locked in position by a spring loaded latch. Normally, the left tractor is located in the third notch from the left.

The form widths associated with the most-used notches are:

First notch – 5-1/2 to 18-3/4 inches (140 to 476 mm)

Second notch – 4-1/2 to 17-3/4 inches (114 to 451 mm)

Third notch – 3-1/2 to 16-3/4 inches (89 to 425 mm)

Ninth notch – 3-1/2 to 10-3/4 inches (89 to 273 mm)

The right-hand tractor is locked into place by spring-locked pins snapped into any of 27 holes on the tractor slide bar.

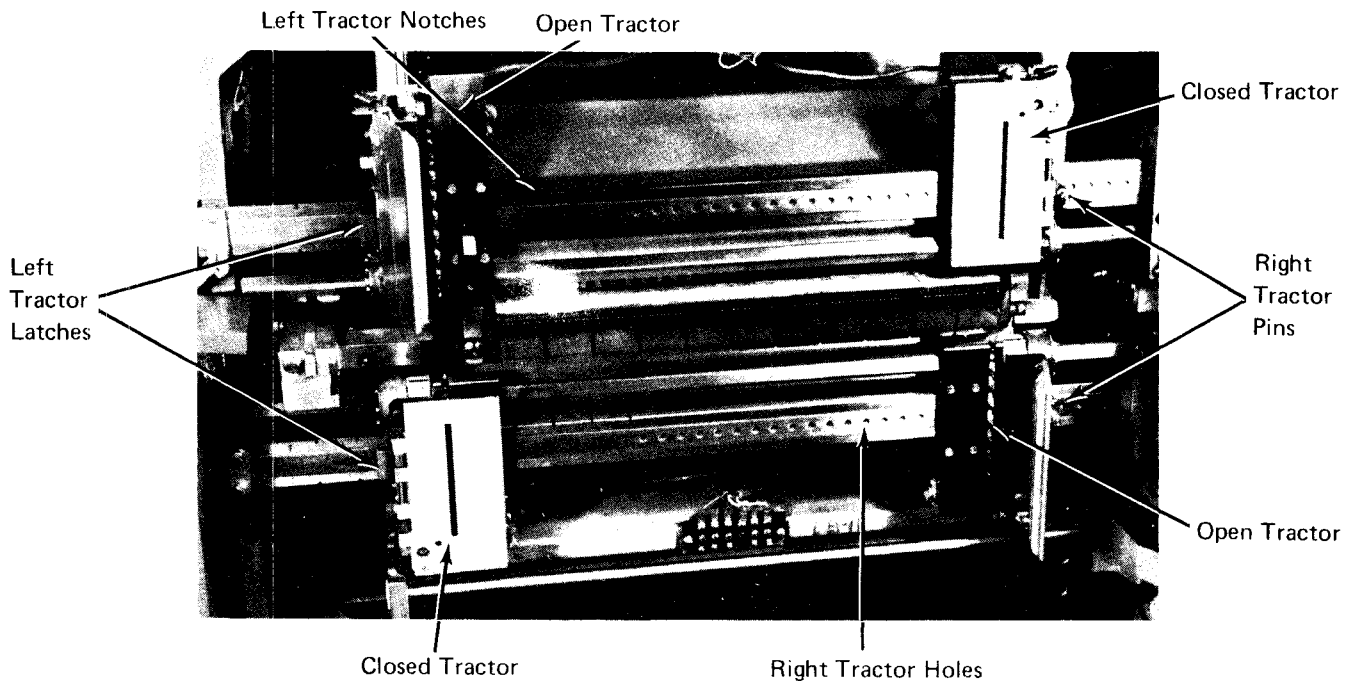
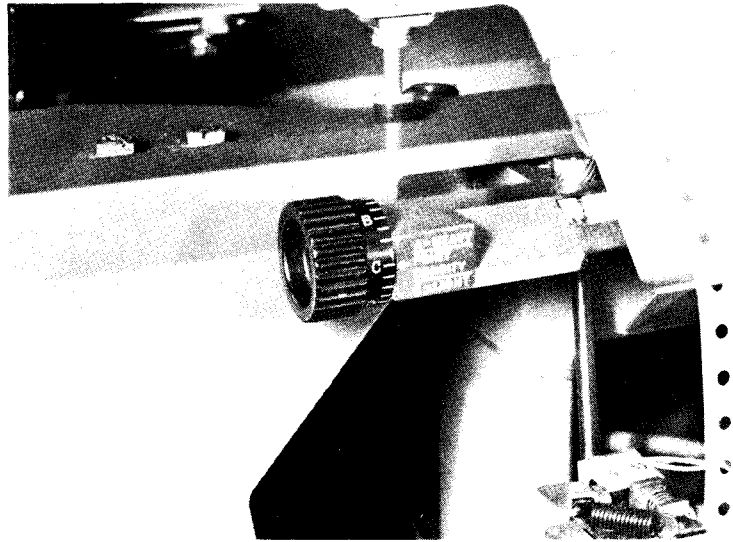
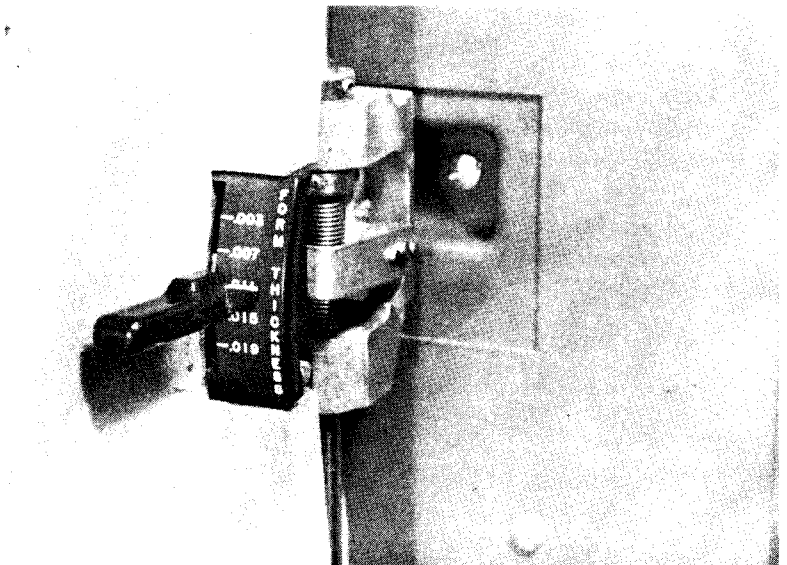

Figure 31. Tractor Slide Bars

*Print Density Control Knob:* This knob regulates the density of the printed characters. The knob is on the upper-left side of the printer frame. When this knob is set at A, the print impression is the darkest; when set at F, the impression is the lightest. C is the normal setting.



*Form-Thickness Lever:* This lever controls the print impression to accommodate forms thicknesses or multiple copies of forms. This lever is at the right end of the ribbon cover.



## LOADING THE CARRIAGE CONTROL TAPE

A prepunched carriage control tape is provided with the machine. This tape is long-lasting and requires no attention other than infrequent inspection for wear. The part number for this prepunched tape is 428470. To change the carriage control tape:

1. Raise the printer cover.
2. Turn the feed clutch to neutral.
3. Press the latch on the side of the brush holder, and raise the assembly.
4. With the printing on the outside of the tape loop, place the tape over the pin feed drive wheel so that the pins engage the holes in the tape. Make sure that the line position numbers are on the right side of the tape loop, as seen from the front of the printer.
5. Place the other end of the tape loop around the adjustable carriage-control tape idler.
6. Adjust the idler by loosening the locking knob and moving the idler in its track. There should be no noticeable slack in the tape nor should the tape be overly tight. Test the tape by pressing the sides of the loop together; there should be some give. If the tape is too tight, the pin holes will be damaged. Be sure to retighten the idler locking knob.
7. Lower the brush assembly. A click can be heard when the latch engages.
8. Press CARRIAGE RESTORE. When the tape has returned to home position (line count 1), engage the feed clutch.
9. Close the printer cover.

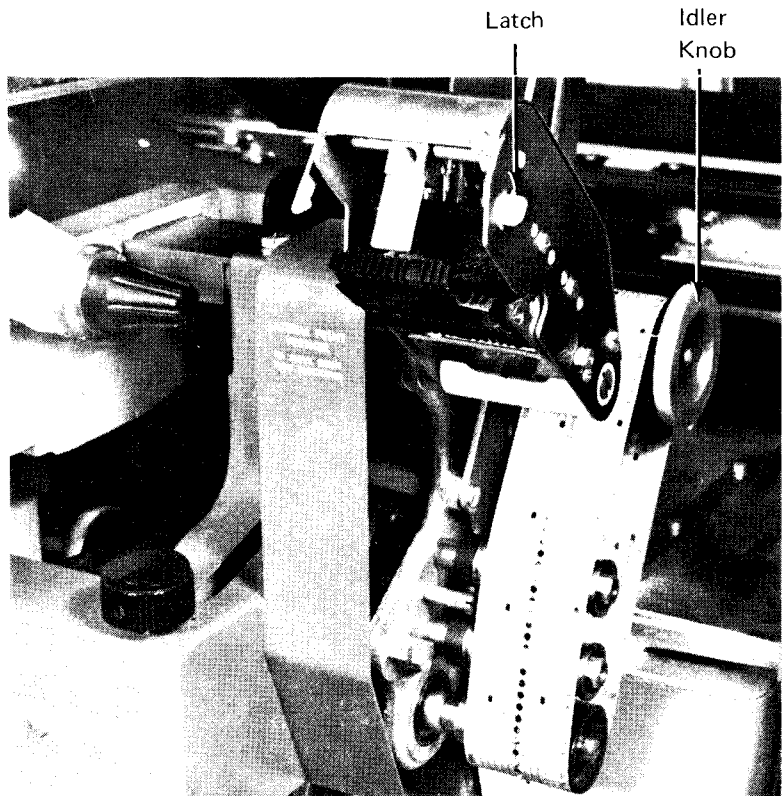



## LOADING FORMS

1. Raise the printer cover.
2. Turn the feed clutch to neutral.
3. Unlock the print unit release lever and swing back the print unit.
4. Set both the left-hand forms tractors slightly to the left of the first print position. Move the tractor to the left until it latches in the appropriate notch.
5. Open the left-hand tractor covers and place the forms over the tractor pins. Close the covers.
6. Open both right-hand tractor covers.
7. Pull out the tractor pin-latch and slide the right-hand tractors into the location where they line up with the right side of the forms. Slide the tractor so that the pin-latch snaps into the appropriate position.
8. Place the forms over the right-hand tractor feed-pins and close the tractor covers.
9. Tighten tension on the form by using the right-hand tractor vernier. The paper has the correct tension when it lies flat across the printing area and the tractor pins are centered in the pin holes.
10. Position the form by turning the paper advance knob until the line, block, or area on which the first line is to be printed is just visible above the ribbon guide bar.
11. Align the desired hammer position (print position) to the form with the lateral print alignment lever and vernier. Notice the relationship of the form to the markings on the ribbon guide bar to determine the correct position.
12. Turn the paper advance knob backward four line positions if you are printing six lines per inch (25.4 mm) or five line positions if you are printing eight lines per inch (25.4 mm). The form is now properly positioned.
13. Close and lock the print unit. Be sure to push the print-unit release lever as far back as possible.
14. Press CARRIAGE RESTORE to return the carriage control tape to home position (line count 1).
15. Set the feed clutch to drive for either six or eight lines per inch (25.4 mm) depending on the form to be printed.
16. Close the printer cover.
17. Position the paper supply so the forms feed straight up into the machine.
18. When printing begins, guide the first form between the forms stacker guide and the machine. Adjust the first forms in the stacker so that they fold flat.

Forms stacking is automatic as the paper is fed out of the machine. As the forms enter the stacker, they pass between the powered stacker rolls and a set of idler rolls. You can disengage some or all of the idler rolls to regulate the tension on the forms. The stacker consists of an adjustable stacking guide and a hinged forms guide. The adjustable stacking guide can be shifted from front to back by engaging it in different holding slots at the top. The hinged forms guide can be adjusted from front to back by sliding the paper tray in or out. To ensure good forms stacking:

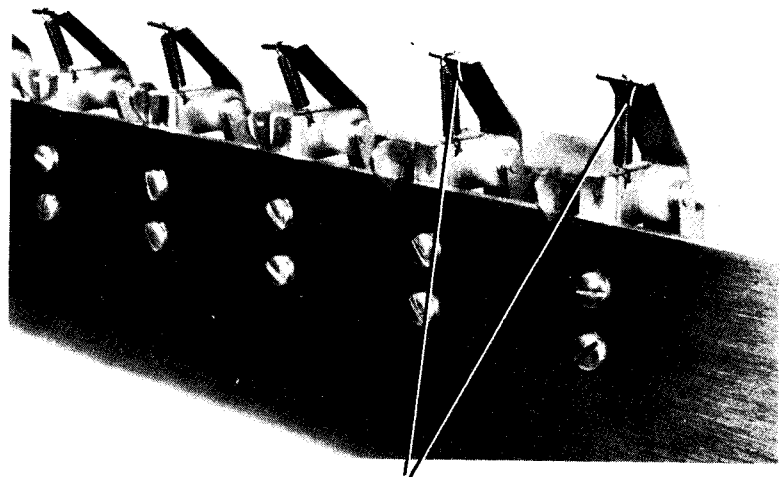

Two Rightmost Idler Rolls Disengaged

1. Position the adjustable stacking guide and the hinged forms guide so that the stack of printed forms is centered beneath the stacker rolls.
2. Starting at each edge of the form and progressing toward the center, engage only as many idler rolls as are required to pull the forms smoothly from the printer into the stacker. This is especially important with multiple-part forms.
3. Initially, set the stacker rolls about 5 inches (127 mm) above the top of the stack. Raise them whenever the distance to the forms stack is less than 2 inches (51 mm). For heavy forms or for forms that have no skips of over 5 inches (127 mm), the distance from the idler rolls to the forms stack can be greater than 5 inches (127 mm).
4. Occasionally, compress the stack by pressing on the paper to squeeze out any trapped air and maintain a flat stack.

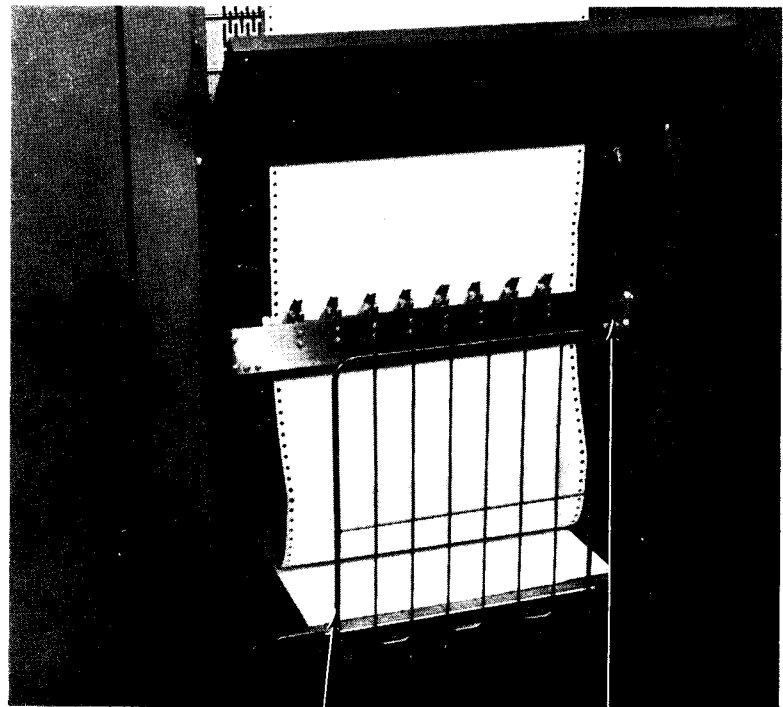

Hinged Forms Guide

Adjustable Stacking Guide

## CHANGING THE PRINTER RIBBON

1. Raise the printer cover.
2. Pull back the print-unit release lever and swing out the print unit.
3. Open the top ribbon cover.
4. Unlatch the print-line indicator ribbon shield and swing it away from the ribbon.

*Note:* If plastic gloves are provided with the ribbon, put them on at this time.

5. Push the top ribbon roll to the right (the hinged side of the print unit). Lift out the left end of the roll and remove the roll from the drive end of the mechanism.

6. Slip the ribbon from under the ribbon correction roller.

7. Remove the bottom ribbon roll by pushing the roll to the right, lowering the left end of the roll, and removing it.

8. Place the new ribbon spool on the bottom spindle. The new ribbon should be installed as shown in the diagram.

9. Place the right end of the full spool in place on the bottom spindle. Push the spool to the right and put the left end on the spindle.

10. Put the ribbon in place as shown.

11. Slide the ribbon under the ribbon correction roller.

12. Place the right end of the top spool in place on the top spindle. Push the spool to the right and put the left end on the spindle.

13. Set the ribbon width lever to correspond to the width of the ribbon.

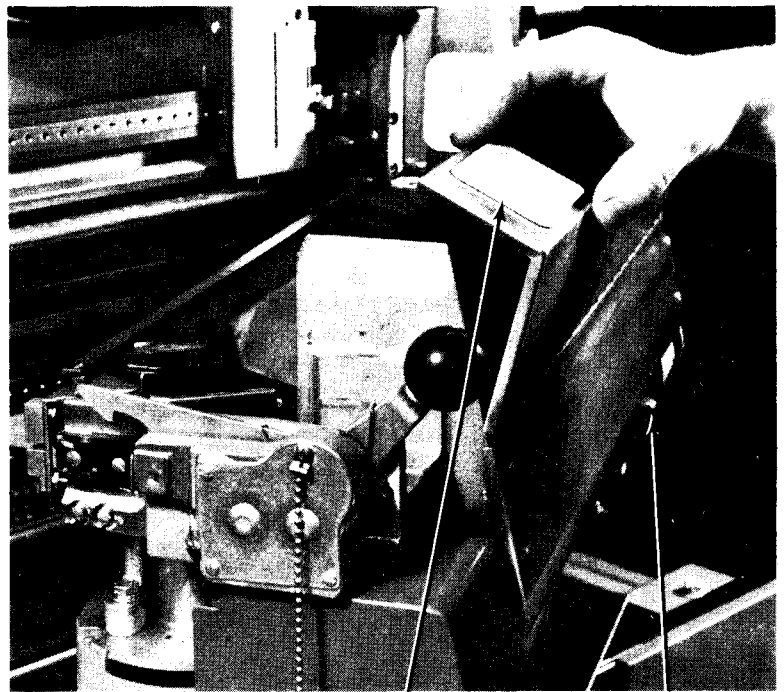

Top Ribbon Cover

Ribbon Width Lever

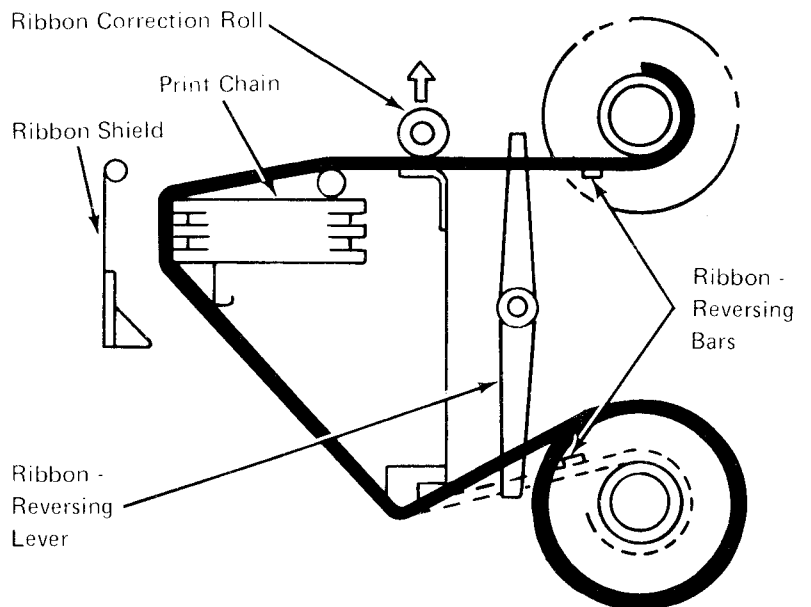

14. Hand-tighten the ribbon to remove any slack from in front of the printing mechanism.
15. Close the top ribbon cover.
16. Close and lock the print unit. Be sure to push the print-unit release lever as far back as possible.
17. Close the printer cover.

#### CHANGING THE PRINT-TRAIN CARTRIDGE

1. Raise the printer cover.
2. Pull back the print-unit release lever. Swing out the print unit.
3. Open the top ribbon cover.
4. Unlock the print-line indicator and swing it against the form.
5. Remove the top ribbon spool, as described under *Changing the Printer Ribbon*, and place it on the tray at the bottom of the print unit.
6. Pivot the two handles on top of the cartridge to their vertical positions. The cartridge is now unlocked and can be lifted out of the print unit by the handles.

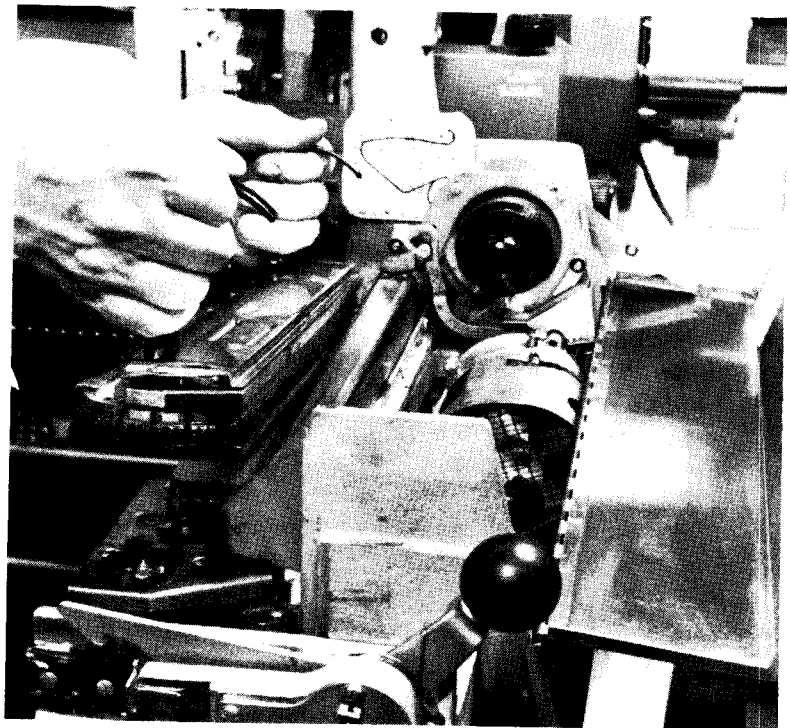

- Using the special tool attached to the printer, turn the notched driver on the right side of the print unit until a screw is visible in the nearby window in the cover plate.

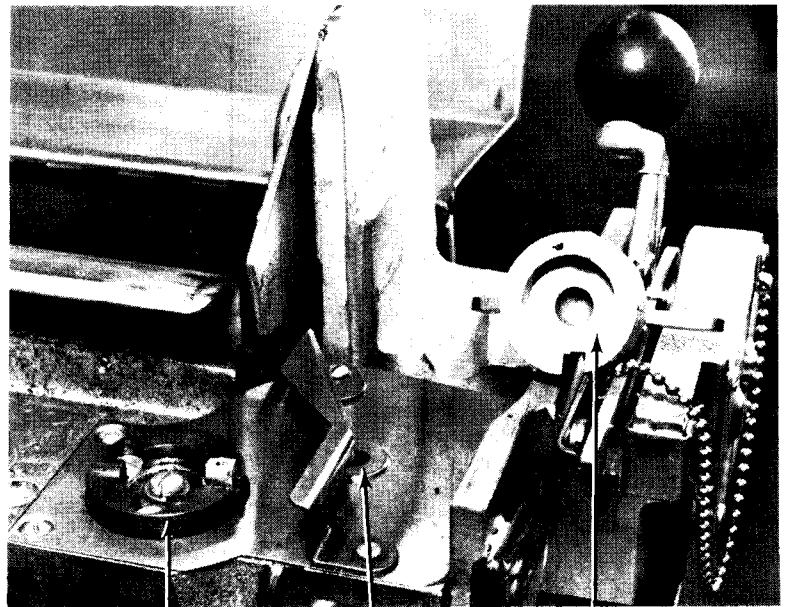

Cover Plate

Window

Special Tool

- Using the same tool, turn the driver gear in the new cartridge until the appropriate character (usually the character 1) on the specially marked slug is in line with the arrow engraved on the cartridge case. If the new cartridge does not have a specially marked slug, align any character 1 with the arrow.
- Place the cartridge on its locating pins in the print unit.
- Lock the cartridge in place by pivoting the handles down into their original position.
- Replace the ribbon spool as previously described under *Changing the Printer Ribbon*.
- Close and lock the print unit. Be sure to push the print-unit release lever as far back as possible.
- Close the printer cover.

## CONTROLLING PRINT QUALITY

Your printer applications often require adherence to strict print-quality requirements, such as when the printer output must be used as input for optical character recognition (OCR) devices. You then must take certain precautions to ensure acceptable print quality. These include:

1. Using recommended ribbon and paper-weight combinations (usually specified on the job setup sheet).
2. Supervising and adjusting print density as required.
3. Replacing the ribbon as required (see *Changing the Printer Ribbon*).
4. Cleaning the type faces.

### Print-Density and Forms-Thickness Adjustments

In applications where print quality is critical, correct print-density and forms-thickness adjustments are important. The forms-thickness adjustment must correspond to the thickness of the forms used. If the thickness cannot be measured directly, obtain this information from the supplier. The forms tractors must be adjusted so that the forms are as tight as possible without tearing or bursting (see *Loading Forms*).

Because each printing format causes unique ribbon wear, you should adjust the print density during a job to ensure even print quality throughout the application. You can correct print-density conditions as follows:

1. Set the forms-thickness lever to correspond to the forms being used. Set the print density control knob for the best impression.
2. If the tops of the characters are lighter than the bottoms, increase the setting of the forms-thickness lever. If the bottoms are lighter than the tops, reduce the forms-thickness setting.
3. If characters appear to be slurred, reduce the print-density setting.

**HHHH** Light Tops

**HHHH** Slur (excessive width of vertical strokes)

If these adjustments do not correct the problem, call IBM for hardware support.

## Type-Face Cleaning

For best results, you should clean the type faces periodically: first with a vacuum cleaner, then with type-cleaning paper (such as IBM part 451529 or its equivalent). Type cleaning paper is a crepe-like paper with a tacky surface. Dirt from the type adheres to its surface.

*Note:* Under no circumstances should the print chain be cleaned by any other method.

1. Open the printer cover.
  2. Open the print unit and remove the ribbon.
  3. Remove the forms.
  4. Vacuum the cartridge, type faces, and print areas.
  5. Install the type cleaning paper on the tractors, just as you would any other form. Make sure the crepe side is facing you.
  6. Position the paper and tractors so that the entire print area is between the perforated margins.
  7. Close and lock the print unit.
  8. Set the print-density control knob to C and the forms-thickness lever to 0.015 inch (0.38 mm).
  9. Put the feed clutch in neutral and press CHECK RESET. This turns off the FORMS CHECK indicator.
  10. Leave the printer cover open and load a program that will print all the characters on the chain. Press START.
  11. Using the paper advance knob, manually space the paper every five or six lines until the type faces are clean. The type faces are clean when a very light line is printed.
- Note:* Avoid printing more than ten print lines before advancing the paper because the crepe surface may shred. Shreds may lodge between the type slugs and cause serious damage to the print chain.
12. Remove and discard the cleaning paper.
  13. Reinstall the ribbon and forms.
  14. Close the printer cover.

- Controls
- Power On Procedures
- Loading Forms
- Changing the Printer Ribbon

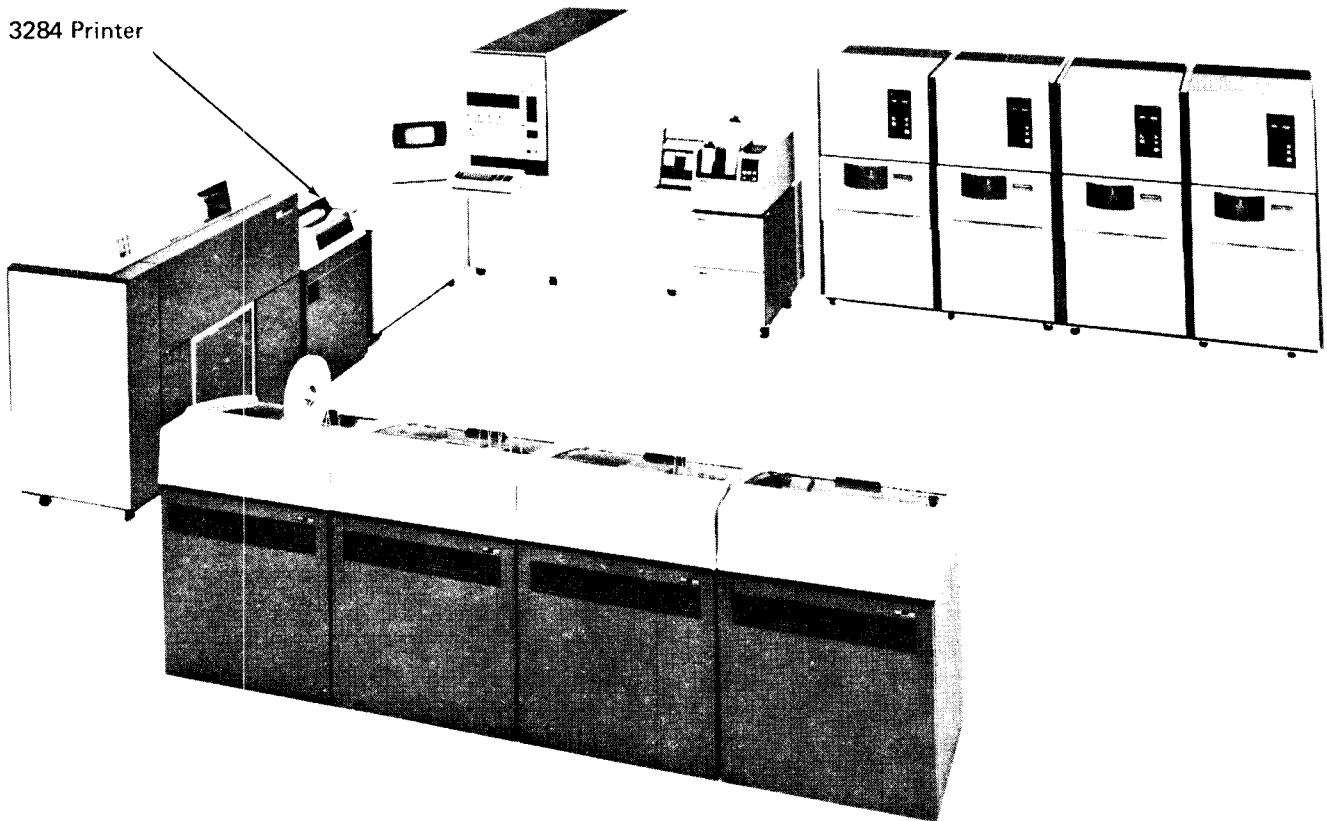

## CONTROLS

### Switches

The 3284 printer has switches in two locations; a power switch, located on the left side of the front cover and below the print mechanism, and test/printer switches, located under the plastic cover and to the left of the platen.

**POWER Switch:** This switch must be in the ON position for the 3284 to be used. When the 3284 is not going to be used, this switch may be in the OFF position.

### Test/Printer Switches

All positions of the test/printer switches (Figure 32) are used for servicing the printer. Some positions you use and the others are used by customer engineers when servicing the device.

#### **DANGER**

Anytime that you use a test switch, be sure to keep your hands away from the print head as it moves across the platen.

**Test Switch:** Put this switch in the ON LN position for normal printer operation. Put it in the PRINT PAT position to print a test pattern of characters or to change the printer ribbon. The PRINT BFR position is normally only used by customer engineers to print the contents of the buffer after an error has occurred.

**Printer Switches:** These two switches must be used in sequence. When the test switch is in the PRINT PAT position, you can use the printer switches. You can choose either of two print patterns by placing the left printer switch in the MODE 1 or MODE 2 position. (Normally only the MODE 2 position is used. It prints a line of Hs that can be used for precise paper alignment.) The right switch activates the printer to print out the selected pattern. To do this, push the switch to the START PRINT position and release it.

### Paper Handling Controls

To see the paper handling controls, raise the top cover by placing your fingertips under the recessed front edge of the cover and lifting it up. With the cover raised, the controls shown in Figure 33 are visible.

**Copy Control Lever:** You use this lever to adjust the space between the platen and the print head. This allows forms of various thicknesses to be used in the printer. Set the lever in the first position (closest to the front of the printer) for one-part forms. For multiple-part forms or thicker forms, set this lever in position 2, 3, 4, or 5. Position 5 is closest to the back of the printer and accommodates the thickest forms.

**Paper Advance Knob:** You position paper in the printer by using the paper advance knob. When you turn the knob, the paper is moved with the platen, one line at a time. To adjust for exact positioning of the paper, push the paper advance knob in and turn it until the paper is in the desired position. This adjustment lets you position the print head to an exact print line on the form. Further instructions for this adjustment are included later in this chapter under *Loading Forms*.

**Note:** Line control is performed for the 3284 by the programming system. When you move the paper advance knob, the program receives no indication of the move. Therefore, if you are using line control, you should always be sure the paper is returned to the original position if the paper is moved or if the forms are changed.

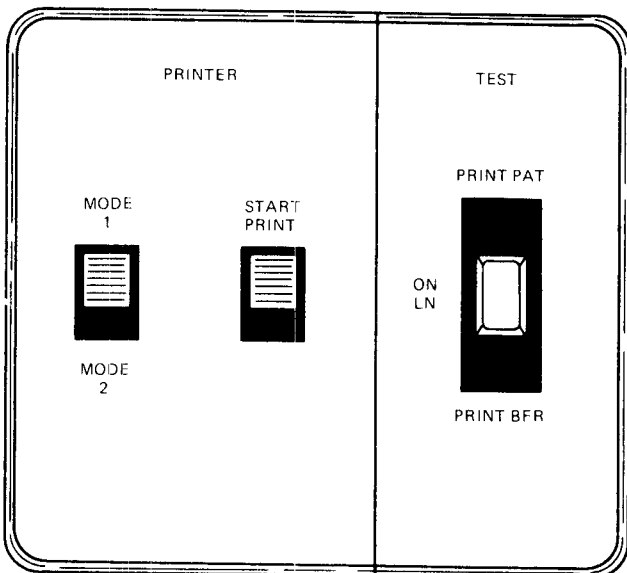

Figure 32. Test/Printer Switches



*Line Feed Selector Lever:* You select single spacing by putting this lever in the forward position (closest to the front of the printer). You select double spacing by pushing this lever back.

## POWER ON PROCEDURES

When the system power is on, you can turn on power to the 3284 by moving the POWER switch to ON. Periodically, you may want to check the position of the line being printed on the form and the print quality. If so, perform the following procedure to turn on power to the 3284.

1. Raise the top cover.
2. Put the test switch in the PRINT PAT position.
3. Close the top cover.

### **DANGER**

Be sure you close the top cover at this time to prevent coming in contact with the print head, which will move across the carriage as you perform the rest of this procedure.

4. Turn the POWER switch on. Watch to see that the platen turns to the next line position and that the print head moves across the carriage and returns to print position 1.
5. Put paper in the printer, if necessary (see *Loading Forms*, later in this chapter).
6. Open the top cover and place the printer switch in the MODE 2 position.
7. Push the right printer switch to the START PRINT position and release it. The printer automatically prints a line of Hs. If the characters are weak and difficult to read, replace the ribbon according to the procedure under *Changing the Printer Ribbon*, later in this chapter.
8. Open the top cover and put the test switch in the ON LN position.
9. Close the top cover.

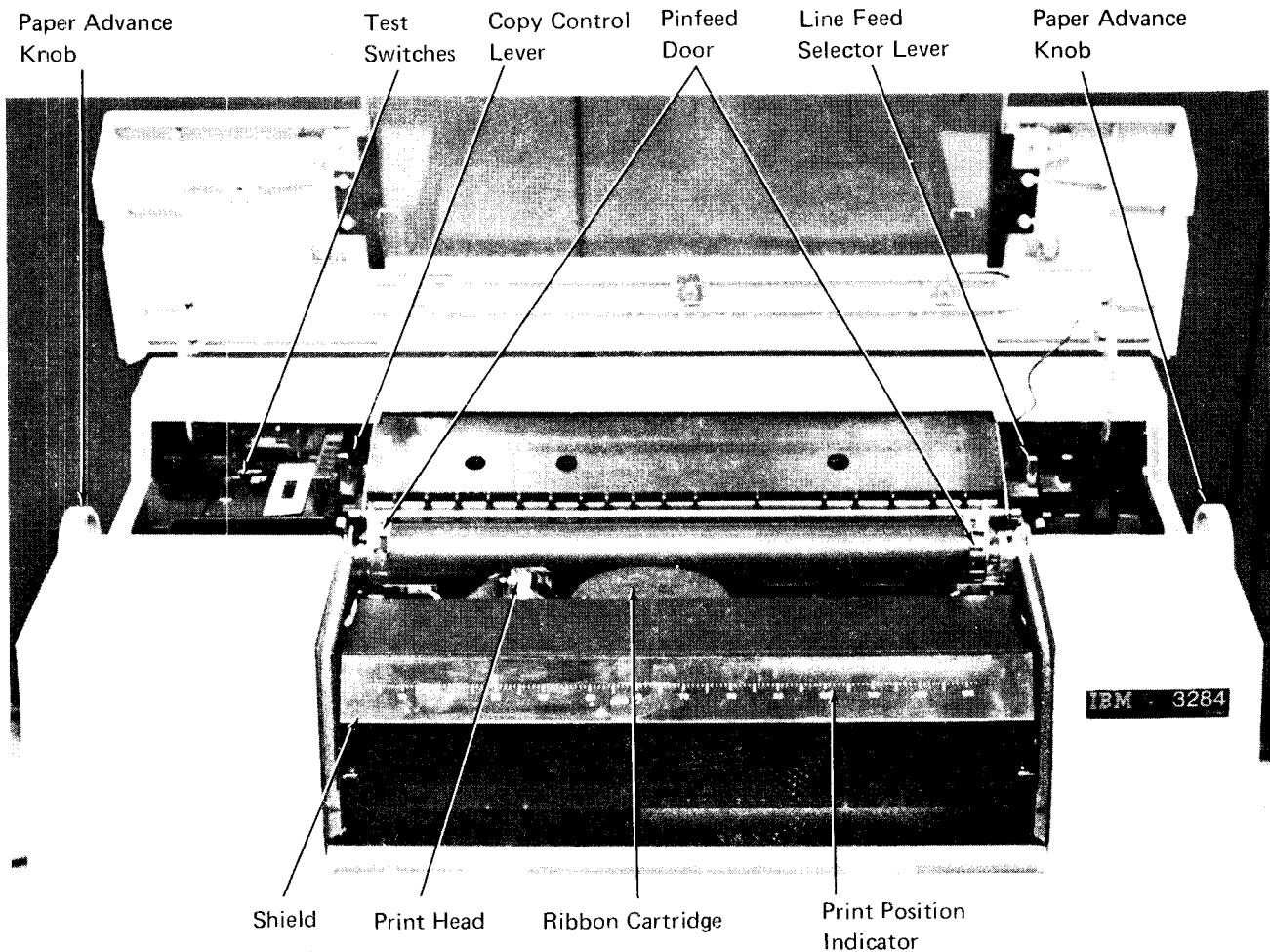

Figure 33. Paper Handling Controls

The 3284 printer is now ready for operation. If it does not operate, raise the top cover and perform the following checks.

1. Check that the paper is correctly installed by rotating the paper advance knob a few times. The paper should move evenly with the platen.
2. Check that the test switch is in the ON LN position and that the POWER switch is on.
3. Close the top cover; be sure that it is tightly closed.

If the printer still does not operate, contact IBM for hardware assistance.

*Note:* Before turning the POWER switch off, be sure the last printout is completed.

### LOADING FORMS

When a forms stand is provided, paper forms are placed on the lower platform of the forms stand and are inserted through a slot at the rear of the printer. They pass between the platen and the print head and exit over the top of the printer. The forms are then stacked on the top platform of the forms stand. Figure 34 shows how forms are stacked on the forms stand and where the forms enter and exit the printer. When the printer runs out of paper, the platen rotates for a short time, causing a clicking sound. Also, when paper runs out, the 3284 not-ready message is displayed on the CRT screen.

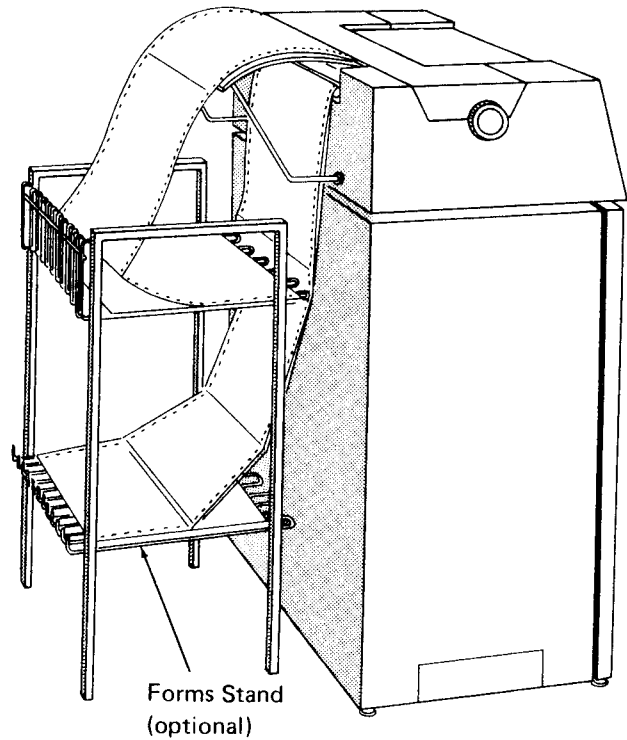
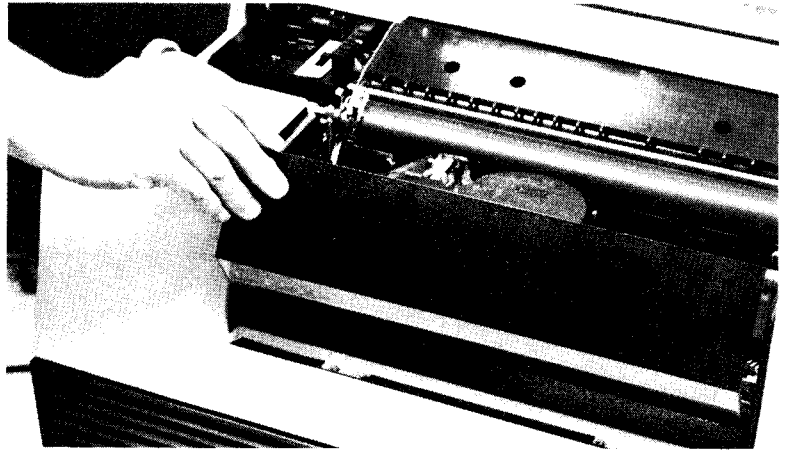

Figure 34. Printer with Forms Stand

To insert paper, face the front of the printer and perform the following:

1. Open the top cover.
2. Raise the plastic safety shield containing the print position indicator by pulling upward on the shield edge near the platen.
3. Push the copy control lever back to allow the maximum opening between the print head and the platen.
4. Raise both doors covering the pinfeed mechanism at the ends of the platen.



From the rear of the machine, perform the following:

5. Check that you have the correct sized paper for the printer. The paper may be 13 inches (330 mm), 13-5/8 inches (346 mm), or 14-3/8 inches (365 mm) wide.
6. If a forms stand is provided, place the new paper forms on the lower rack of the stand.
7. Insert the starting edge of the first form sheet in the paper feed slot, with the side to be printed on facing down. The forms enter easily if started with one corner entering the feed slot first.

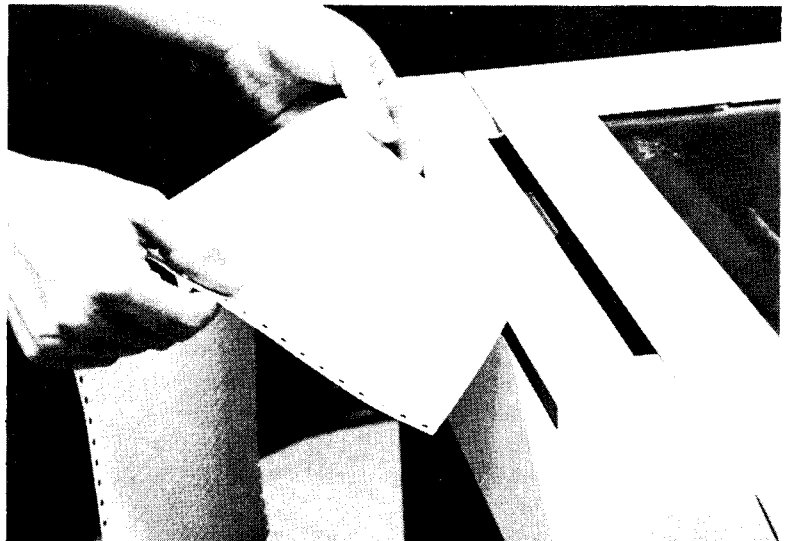

8. Push the forms through the slot until the front edge is seen passing under the platen.

From the front of the machine, perform the following:

9. Pull the front edge of the form forward a short distance, bend it around the platen, and align the paper horizontally until the holes at each side of the paper fit on the pins of the pinfeed mechanism.
10. Close the pinfeed doors.

11. Set the copy control lever to the correct position as required by the number of parts in the form being used.
12. Set the line feed selector lever by pulling forward for single spacing or pushing back for double spacing. To ensure correct form control, this lever must be in the forward position.
13. Press in and rotate the paper advance knob to approximately align the form with the print line. If required to move the form backward, rotate the paper advance knob backward, and pull the form from behind the machine to keep the form from buckling at the print head.

If forms control is used, you must be sure the form is positioned at the proper line. Before the IPL procedure is performed, the form must be positioned at line 1. When an end-of-forms condition occurs, the new form being loaded must be positioned at the same line as the old form was positioned at when the end-of-forms condition occurred. This line number is provided in the message text when the end-of-forms condition occurs.

14. If more precise alignment is necessary, set the test switch to the PRINT PAT position and the left-hand printer switch to MODE 2.

**DANGER**

The next action you take will cause the print head to move. Be sure to keep your hands away from the moving print head.

Push the right printer switch to the START PRINT position and release it. Then close the top cover. A continuous line of Hs is printed. This will show where the print line is on the paper.

If the line printed is not in the correct position on the paper, press in and rotate the paper advance knob to align the form more closely with the print line. Open the top cover and activate the print head using the right printer switch to print another line of Hs.

15. When the paper is properly aligned, set the test switch to the ON LN position. Rotate the paper advance knob to feed the paper through the paper exit slot in the cover.
16. Close the top cover.

**CHANGING THE PRINTER RIBBON**

Figure 35 shows the ribbon cartridge assembly. To remove the ribbon cartridge:

1. Turn the POWER switch off.
2. Raise the top cover.
3. Set the test switch to PRINT PAT and close the cover.
4. Turn the POWER switch on and be ready to quickly turn it off when the print head has moved about halfway across the carriage. If you have trouble centering the print head, return to step 3 and repeat the procedure until the print head is about centered.
5. Raise the top cover.
6. Push the copy control lever back to allow the maximum opening between the print head and the platen.
7. Raise the plastic safety shield containing the print position indicator by pulling upward on the shield edge near the platen.
8. Remove the ribbon from under the plastic guide and from around the guide posts.
9. With your left hand, pull and hold the ribbon cartridge latch while rotating the ribbon cartridge counterclockwise with your right hand to release the cartridge from the aligning fingers.
10. Lift out the ribbon cartridge. If you rotate the cartridge back and forth, it comes out easier.

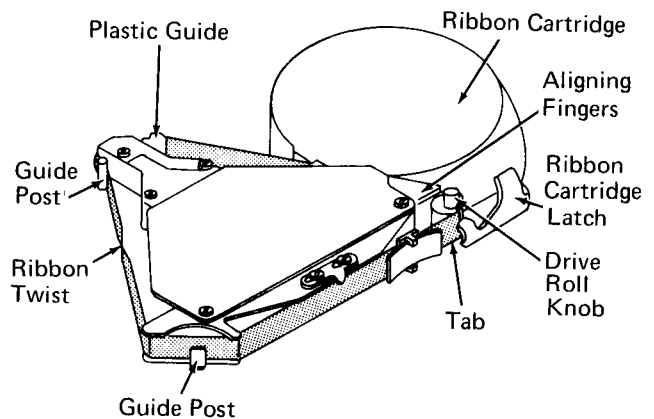

Figure 35. Ribbon Cartridge Assembly

To install the new ribbon cartridge:

11. With your left hand, pull and hold the cartridge latch.
12. Seat the cartridge on the pivot, and rotate the cartridge clockwise to engage the aligning fingers with the aligner.
13. Release the cartridge latch.
14. Thread the ribbon around the print head. (Be careful not to get oil, from the oil wick, on the ribbon.)
15. Work the ribbon under the plastic guide, in front of the print head, and back around the front guide post.
16. Locate the twist in the ribbon between the front and rear guide posts.
17. Place the ribbon over the rear guide post.
18. Remove and discard the tab protecting the ribbon entrance to the cartridge.
19. Rotate the drive roll knob counterclockwise to take up the ribbon slack. Continue rotating the knob until you know the ribbon is feeding properly.
20. Close the safety shield.
21. Set the copy control lever for the thickness of the forms being used.
22. Set the test switch to ON LN.
23. Close the printer cover. Be sure it is tightly closed.
24. Turn the POWER switch on.



## Chapter 10. IBM 3410/3411 Magnetic Tape Subsystem

- Controls and Indicators
- Removing a Reel
- Mounting a Reel
- Replacing Tape Markers
- Cleaning the Tape Head
- Magnetic Tape Handling

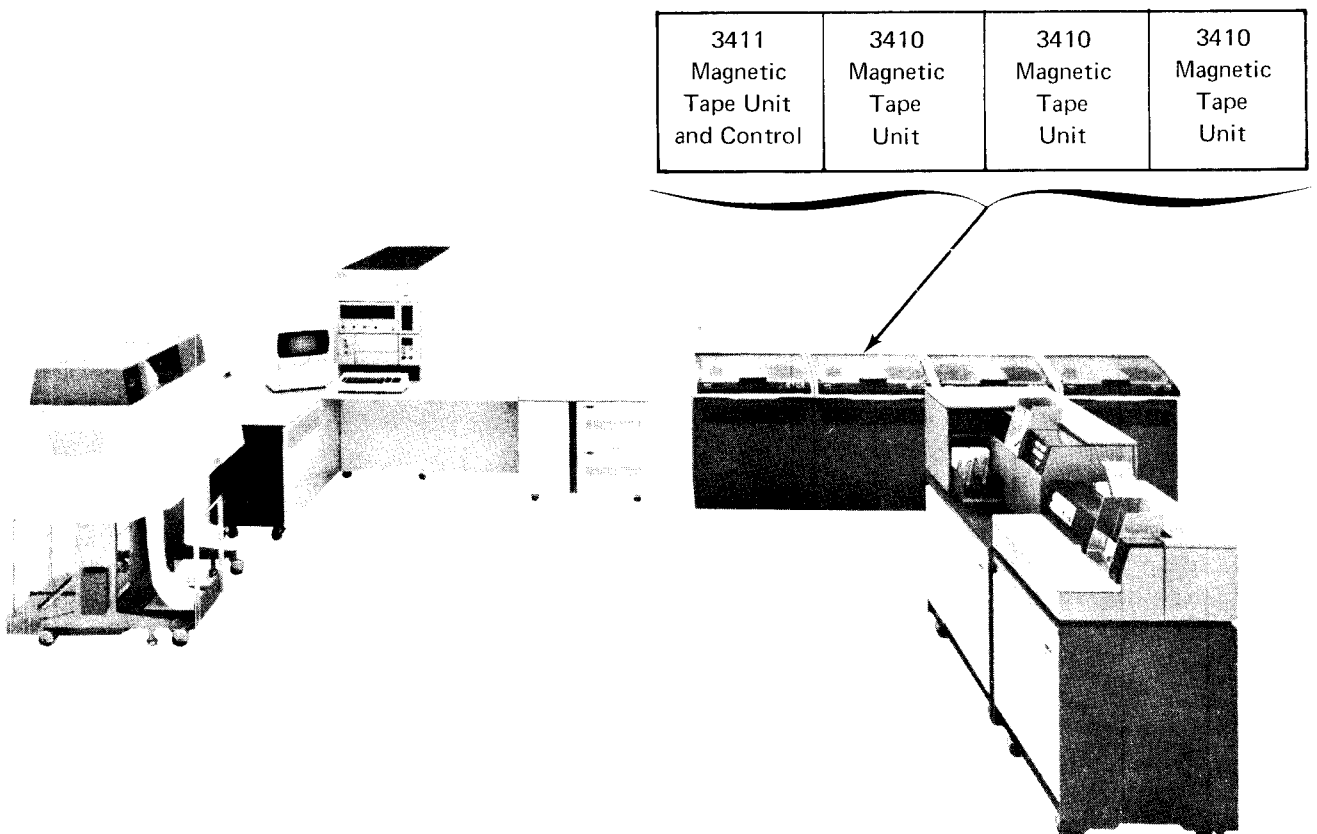

## CONTROLS AND INDICATORS

The operator's panel on the 3410 and 3411 Magnetic Tape Units (Figure 36) contains the following keys and lights:

### Keys

**LOAD REWIND:** Press this key to load the tape into the vacuum columns and position the tape at the load point. If the tape has already been loaded and the **READY** light is off, pressing this key rewinds tape to the load point.

**START:** Press this key to make the tape unit available for system operation. The **READY** light turns on; all keys except **RESET** are disabled. The **START** key may be pressed while the tape reel is moving.

**UNLOAD REWIND:** Press this key to rewind and unload the tape if the **READY** light is off. If the **READY** light is on, the **RESET** key must be pressed before **UNLOAD REWIND**.

**RESET:** Press this key to stop rewinding if the tape is rewinding. If the **READY** light is on and the tape unit is loaded, press **RESET** to turn off the **READY** light before you press **LOAD REWIND**, **UNLOAD REWIND**, or **START**. If the tape unit is loading a tape and you wish to unload it, press **RESET** before pressing **UNLOAD REWIND**.

**ENABLE/DISABLE Switch:** Operation of this switch (located on the 3411 Tape Unit and Control) is interlocked with the system program. The switch must be in the enable position to put the tape control and attached tape units online. The disable position setting takes the tape units offline.

**Note:** A change in the switch setting will not take effect until the CPU usage meter has stopped for at least 25 milliseconds. Some operations (for example, outboard polling of DA or BSCC terminals as is done by CCP) do not allow the meter to stop.

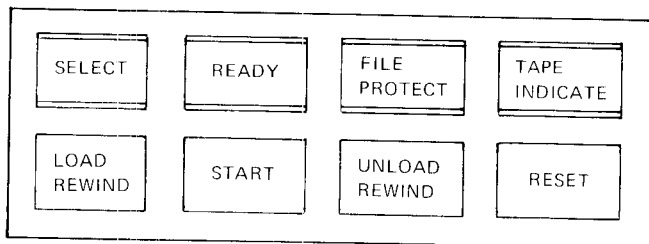

Figure 36. Operator's Panel

### Lights

The lights on the operator's panel indicate the following:

**SELECT:** The tape unit is under control of the tape control unit.

**READY:** The tape unit is available for operation with the tape control unit (columns are loaded, tape is not rewinding, and **START** has been pressed). This does not necessarily mean the tape is positioned at load point.

**FILE PROTECT:** One of three conditions exists:

1. Loaded file reel does not have a write-enable ring; you cannot write on the tape or erase it.
2. No tape reel is mounted.
3. A load, rewind, or unload/rewind operation is in progress.

This light is turned off by mounting a reel that contains a write-enable ring.

**TAPE INDICATE:** The end-of-tape marker was sensed during a forward operation. This light is turned off when the tape moves backward over the end-of-tape marker.

**Usage Meter:** The 3410/3411 usage meter records time as follows:

- The meter starts when the first 3410/3411 command is received.
- The meter is stopped by setting the **ENABLE/DISABLE** switch to disable.



## REMOVING A REEL

1. Press RESET.
2. Press UNLOAD REWIND. The tape rewinds to the load point and is released from the vacuum column.
3. Raise the cover on the tape unit.
4. Unwind the remaining tape by manually rotating the tape reel counterclockwise.
5. Raise the reel latch.
6. While holding the loose end of the tape in place, lift the reel from the spindle.
7. Remove the write-enable ring, if present, and place the reel in the reel case.

## MOUNTING A REEL

If system power is on and no tape reel is mounted on the unit, the FILE PROTECT light is on. Use the following procedure to mount a reel.

1. Raise the cover on the tape unit.
2. Select the reel to be mounted, as indicated on the program run sheet, and remove it from the case. Normally, the write-enable ring will not be present on the reel; therefore, if you want to do an erase or write operation you must insert the ring before mounting the reel.
3. Holding the reel with the write-enable ring groove away from you, mount the reel on the left spindle and press down on the reel latch to lock it in place.
4. With your right hand, feed the tape through the slot at the top of the head cover.
5. Place your finger about 2 inches (50 mm) from the end of the tape, holding the tape against the right spindle. Rotate the spindle in a clockwise direction, allowing the free end of the tape to feed onto the reel.

6. Wrap two or three turns of tape around the right spindle; take up the slack. The load point marker should remain to the left of the read/write head.

*Note:* Make sure you do not load tape beyond the load point marker because when you press the LOAD REWIND key the tape unit will search forward for the load point marker until the end of the tape is reached. If this happens, press RESET to stop the tape, then push LOAD REWIND. The tape will then move backwards to the load point.

7. Close the cover on the tape unit.
8. Press RESET.
9. Press LOAD REWIND. The tape is automatically fed to the tape heads and into the vacuum columns. The load point marker advances to the read/write head.
10. Press START. The READY light turns on.

*Note:* The RESET, LOAD REWIND, and START keys may be pressed in succession without hesitating.

## REPLACING TAPE MARKERS

A load point marker is located approximately 10 feet (3m) from the beginning of the tape; an end-of-tape (EOT) marker is located approximately 25 feet (8m) from the end of the tape. Photosensors on the tape unit detect these markers to determine the beginning and the end of the data. New reels of IBM magnetic tape are supplied with load point and EOT markers.

Occasionally, tape markers must be replaced. If the end-of-tape marker is missing, the tape probably winds completely off the reel and this stops the unit. Replace the tape markers while the tape is mounted in the tape unit as described in the following procedure. To order new tape markers, order part 352407, Magnetic Tape Markers.

Replace the tape marker as follows:

1. If the tape is damaged, cut off the end of the tape, including the old tape marker.
2. *Load Point Marker:* Unwind about 10 feet (3m) of tape (6-7 turns on the right spindle).

*EOT Marker:* Rewind about 25 feet (8m) of tape (about 15 turns on the left spindle).

3. **Load Point Marker:** Place a tape marker on the side of the tape nearest you, parallel to and not more than 1/32 of an inch (0.8 mm) from the edge, but not overlapping the edge.

**EOT Marker:** Place a tape marker on the side of the tape nearest the tape unit, parallel to and not more than 1/32 of an inch (0.8 mm) from the edge, but not overlapping the edge.

4. Press the new marker down firmly.

Clean the unit as follows:

1. Open the head cover.
2. Clean the vacuum columns with the cloth and swabs dampened with cleaning solution; pay particular attention to corners, which can be cleaned easily using a swab.
3. Clean the read/write and erase heads using a swab dampened with cleaning solution.

## CLEANING THE TAPE HEAD

If the tape unit is used daily, the tape head and vacuum columns should be cleaned every day (more often if the unit is used heavily). The following supplies are available from IBM for this purpose:

- IBM Tape Developer Medium and Tape Transport Cleaner, part 453511
- 2108930 Cloth, Lint Free EC422702
- Swabs, part 2754549

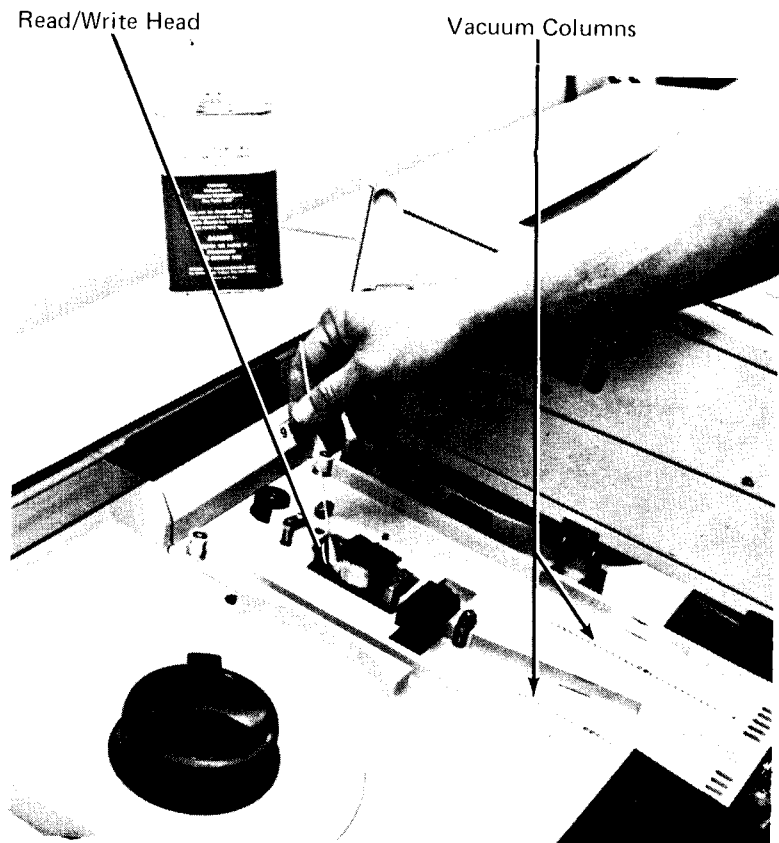

## MAGNETIC TAPE HANDLING

The following suggestions are given to help you get maximum performance from your magnetic tape and tape units:

- Clean tape units frequently, particularly the read/write head and vacuum columns. Dust and dirt can interfere with the contact between the tape and the read/write head.
- Floors, ceilings, walls, draperies, and furnishings in the machine room should be composed of materials that are easy to clean, do not flake, and are free of lint and static.
- Store reel contents where they will not be exposed to dust.
- When a reel of tape is removed from the unit, always place it immediately in a container.
- Do not smoke near tape or tape units, because ashes can contaminate or burn tape.
- Use care in handling tape reels. Dropping or mishandling can damage the tape or the reel.
- To clean the magnetic tape, wipe it gently with a lint-free cloth dampened with tape transport cleaner (see *Cleaning the Tape Head* for available products).
- Inspect reel containers periodically for dust or dirt.
- Do not expose magnetic tape to magnetism.
- If a roll of tape is dropped, inspect it immediately. If the reel is damaged, thoroughly clean the exposed tape and rewind it on a good reel. If you feel the tape may be damaged, you should thoroughly clean it and attempt to check the data through a tape-to-printer job (using an RPG II program) or other operation.
- Do not grasp the tape reel at the outer edges, as the tape may be pinched and thereby damaged.
- Do not turn system power off until all tapes have been rewound and unloaded.



## Chapter 11. IBM 5440 Disk Cartridge and IBM 5444 Disk Storage Drive

- Removing a 5440 Disk Cartridge
- Mounting a 5440 Disk Cartridge

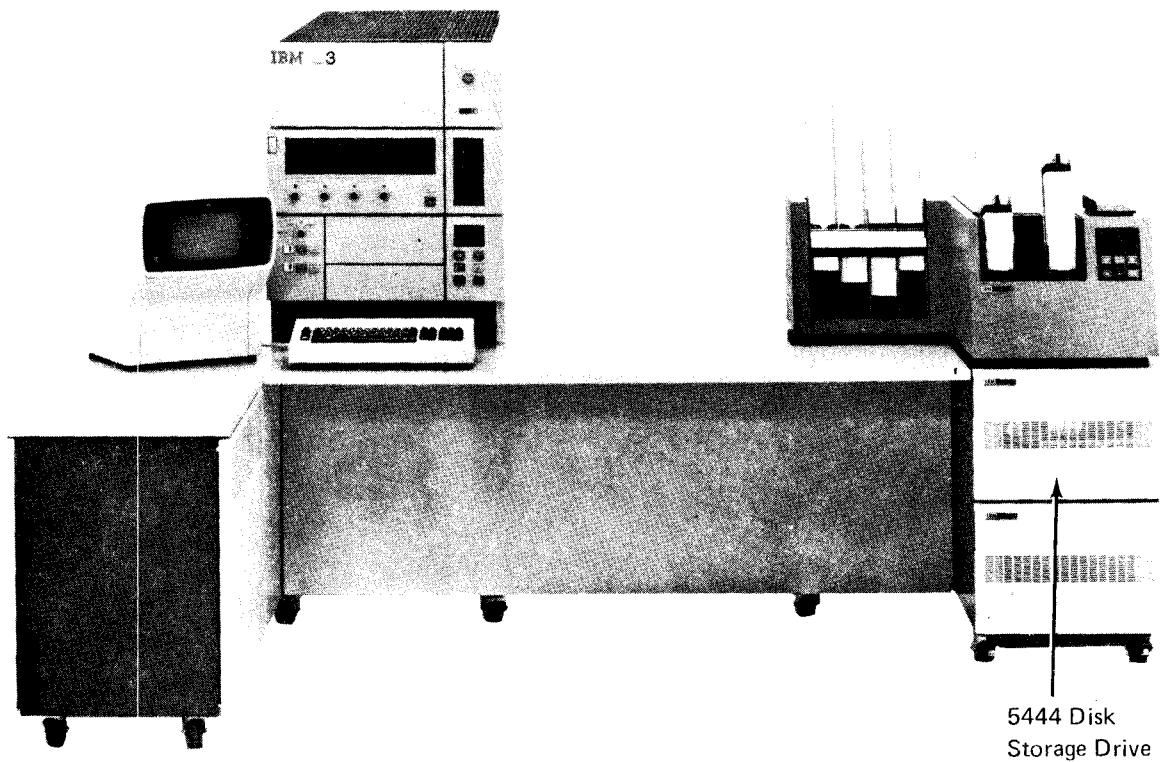

## REMOVING A 5440 DISK CARTRIDGE

1. Set the disk panel START/STOP switch to STOP for the cartridge to be dismantled (R1 or R2).

*Note:* The disk storage drawer cannot be opened until the OPEN light for the selected disk (1 or 2) is on.

2. When the disk panel OPEN light is on (READY light is off), push in the drawer release lever and slide the disk storage drawer out until it stops.

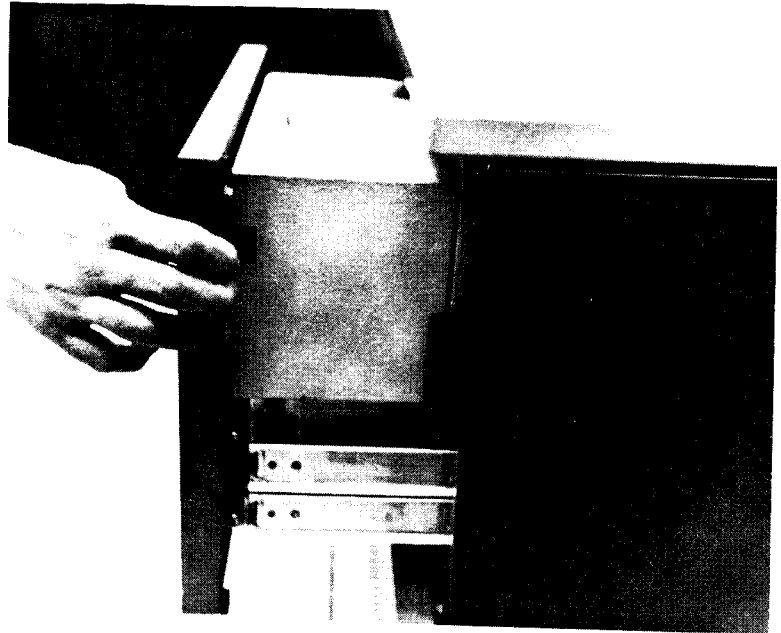

3. Pull both clamp arms outward.

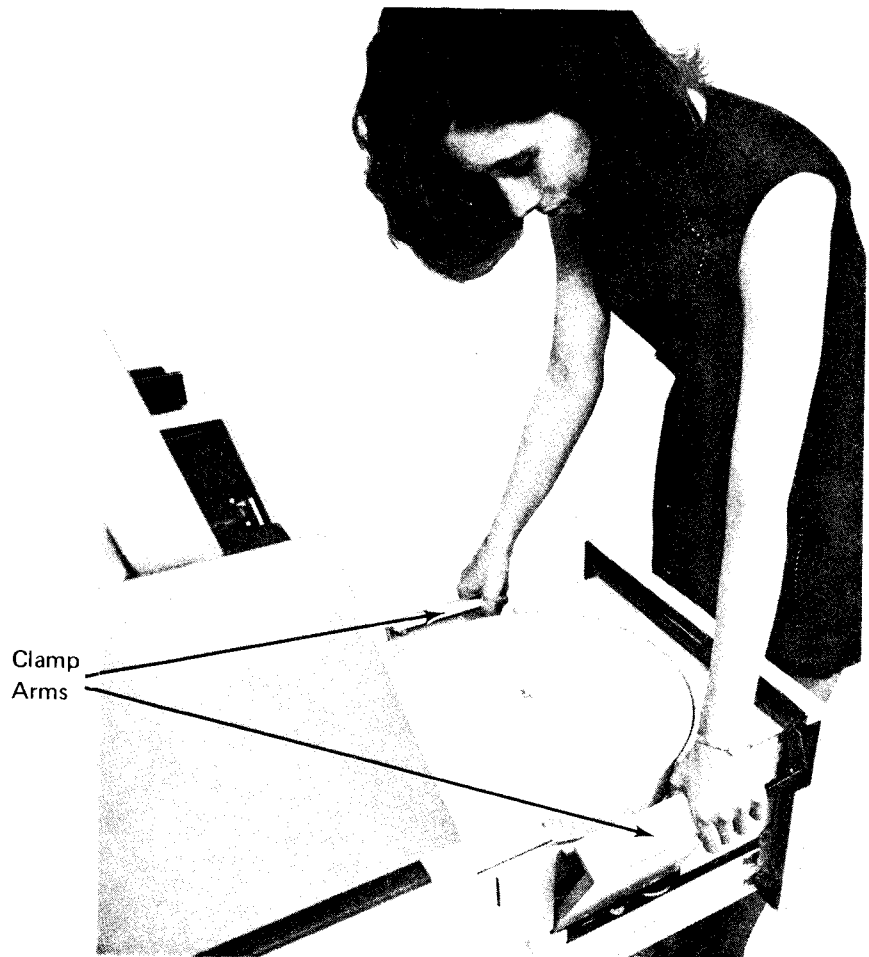

4. Lift the bottom cover off the cartridge.



5. Push the release button to the left and raise the carrying handle to release the cartridge from the disk drive.

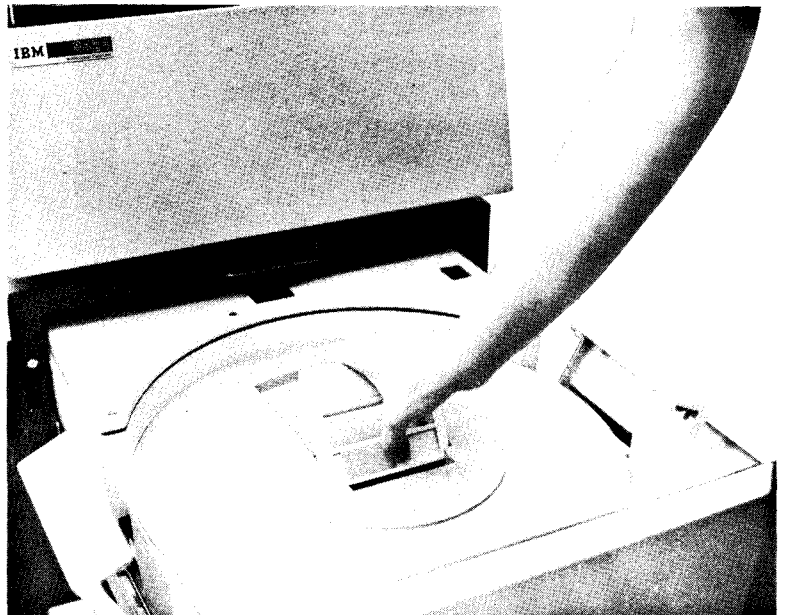

6. Lift the cartridge from the disk drive.

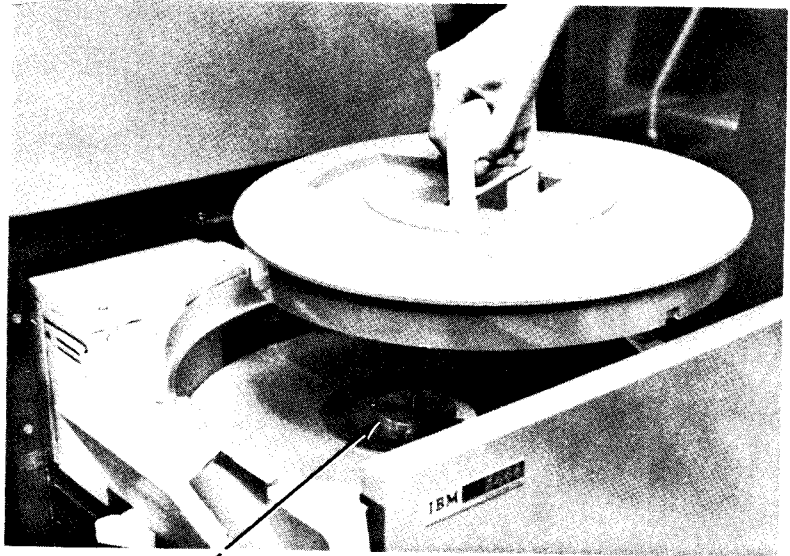

Disk Drive

7. Invert the bottom cover of the cartridge and place it back on the cartridge. Lower the carrying handle until it is flush with the cartridge. This locks the bottom cover on the cartridge.
8. Store the cartridge.

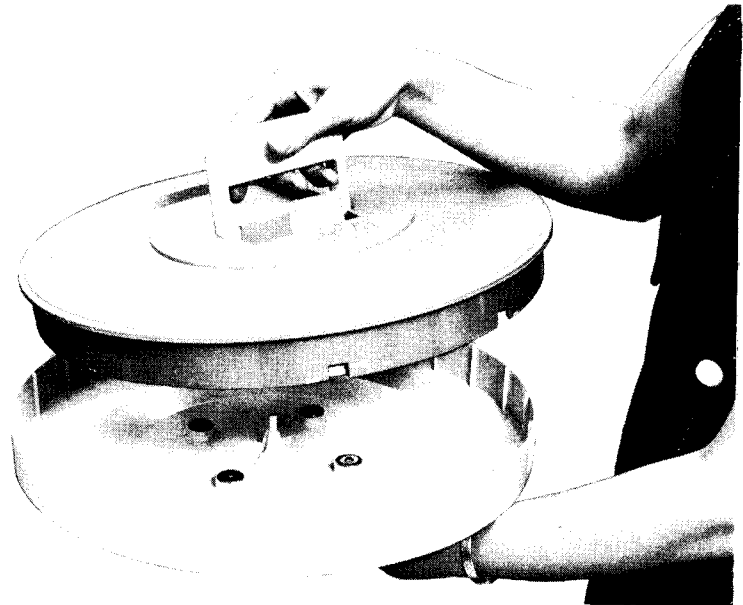



## MOUNTING A 5440 DISK CARTRIDGE

If a cartridge is on the disk drive see *Removing a 5440 Disk Cartridge*.

The cartridge to be used by the system should be in the environment in which it is to be used for at least three hours. This ensures that the disk cartridge can be used properly by the system.

*Note:* A cartridge should always be on the disk drive when the system is not in use. This keeps dust from entering the drive.

1. Check for the following conditions before mounting a cartridge:
  - a. Disk panel START/STOP switch for the drive you are loading (R1 or R2) in the STOP position.
  - b. Disk panel OPEN light on.
  - c. Disk storage drawer open.
  - d. Clamp arms extended.
2. Select the cartridge to be mounted as indicated on the program run sheet.
3. Slide the release button to the left.

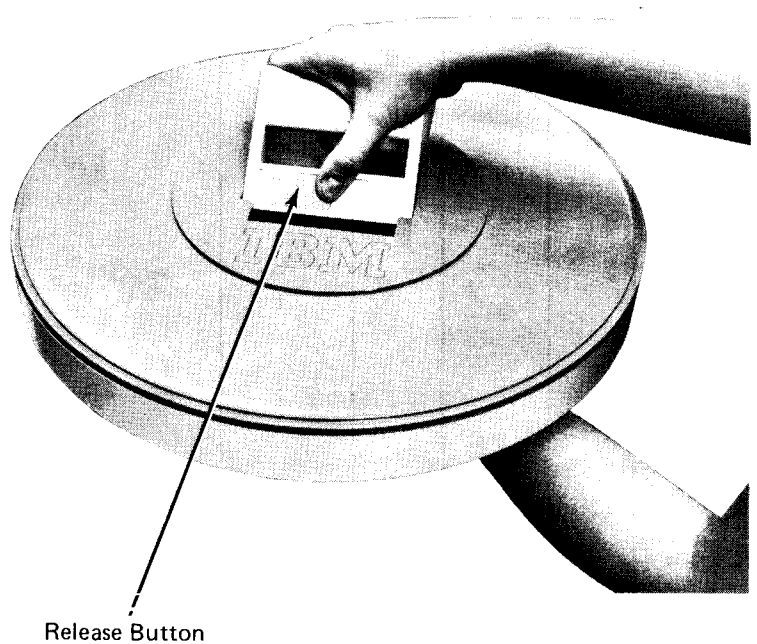

4. With one hand under the bottom cover of the cartridge to catch the cover, raise the carrying handle to the upright position.

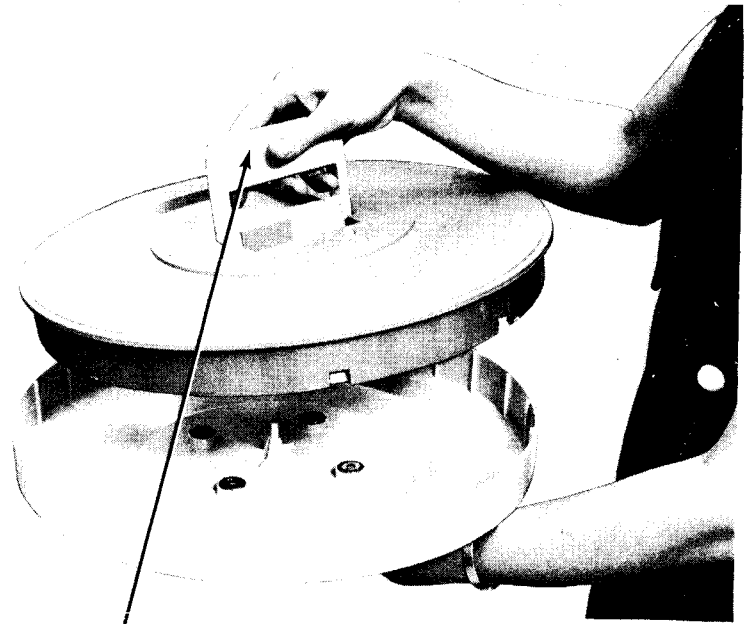

Carrying Handle

5. With the IBM label readable from the front of the disk storage drawer, mount the cartridge by lowering it on the disk drive.
6. Release the carrying handle. It should be flush with the cartridge.

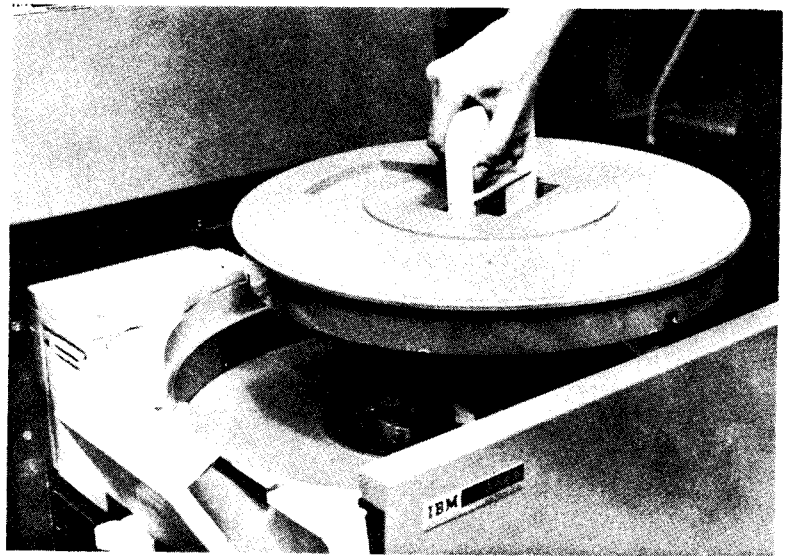

7. Invert the bottom cover and place it on top of the cartridge.



8. Bring in the clamp arms over the cartridge.
9. Close the disk storage drawer.

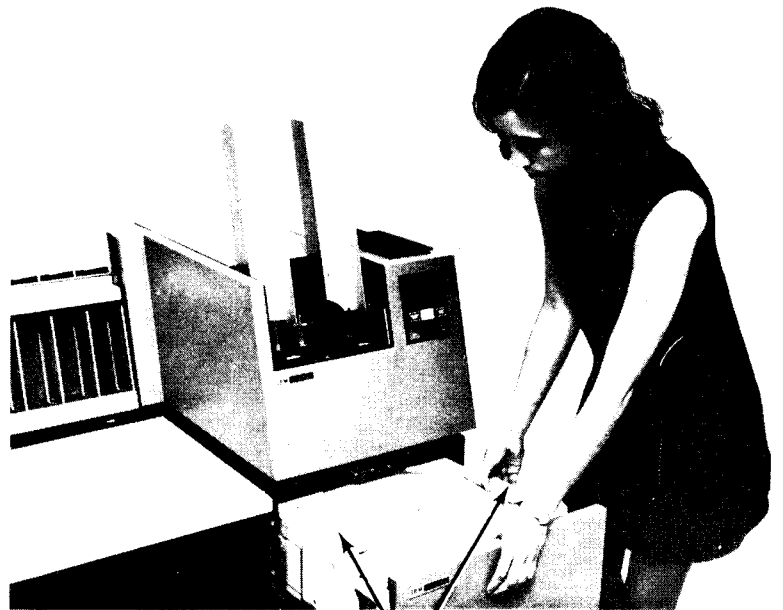

Clamp Arms

10. Set the disk panel START/STOP switch, for the drive you are using, to START. The OPEN light turns off. The READY light turns on when the disk is up to speed. (This takes about two minutes.) When READY turns on, the system can use the disks on the drive.



## Chapter 12. IBM 2316 Disk Pack and IBM 5445 Disk Storage Drive

- Controls and Indicators
- Removing a 2316 Disk Pack
- Mounting a 2316 Disk Pack

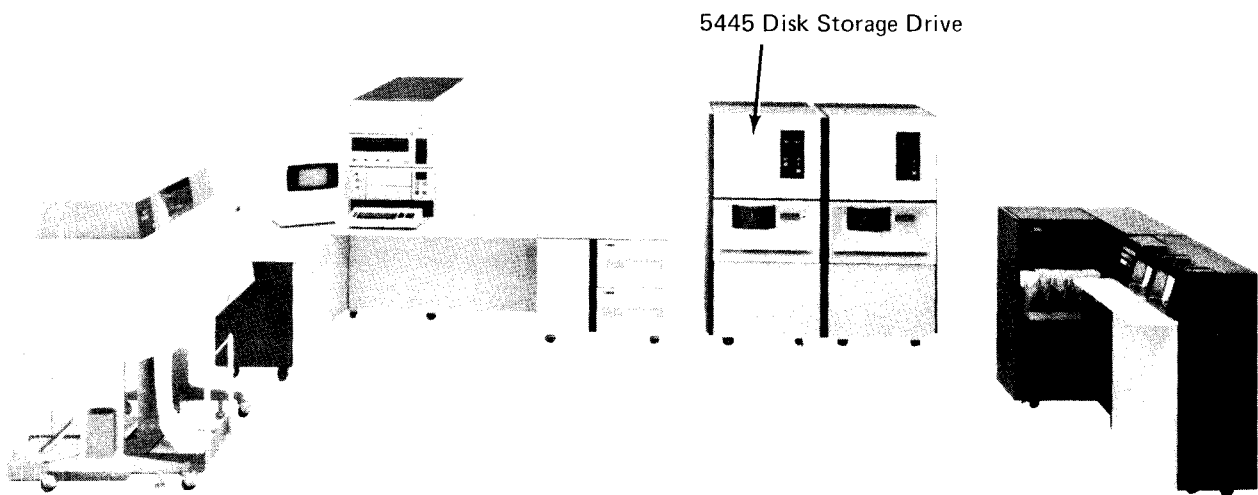

## CONTROLS AND INDICATORS

The panel containing the controls and indicators for the 5445 is at the front of the machine above the disk storage drawer (see Figure 37).

**POWER Switch:** Set this switch to ON on drive D1 (and D3 if present) to turn on control unit power after system power has been turned on.

### CAUTION

Before setting this switch to ON or OFF, press STOP on the system control panel.

**POWER ON Light:** This light is on when the power for the two-drive unit is on.

**READY Light (A):** This light comes on when the 5445 disk drive is ready for use.

**SELECT LOCK Light:** This light comes on when a message was displayed in the program being processed or when the 5445 disk storage drive is malfunctioning.

**START/STOP Switch:** This switch turns the disk drive power on or off when the system power is on. With the switch at STOP, the drawer can be opened and the disk can be replaced.

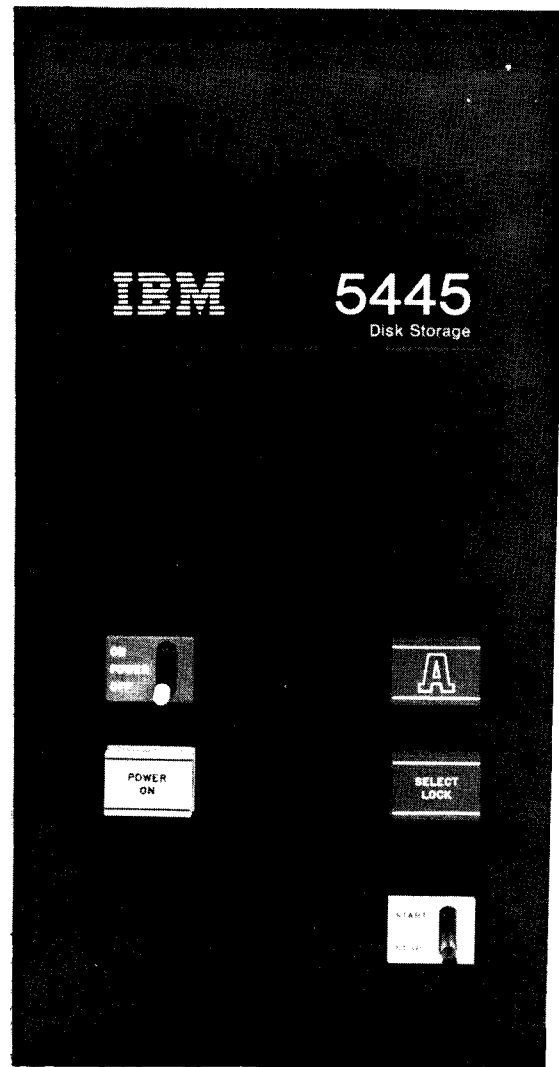
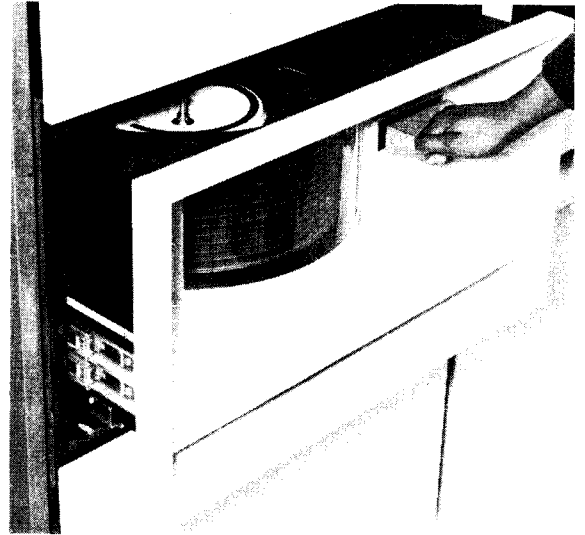

Figure 37. 5445 Controls and Indicators

## REMOVING A 2316 DISK PACK

1. Set the START/STOP switch to STOP.
2. Lift the drawer handle and open the disk storage drawer.



3. Place the top cover on the pack.
4. Turn the top cover handle counter-clockwise until you hear a clicking sound.



5. Lift the pack from the drive.



6. Place the bottom cover on the pack and turn the bottom cover handle until it will not turn.

7. Store the pack.





## MOUNTING A 2316 DISK PACK

If a pack is on the disk drive, see *Removing a 2316 Disk Pack*. The pack you are mounting should be in the same environment as the system for at least three hours before it is mounted to ensure proper use by the system.

*Note:* There should always be a pack on the disk drive when the drive is not in use. This keeps dust from accumulating in the drive.

1. Set the START/STOP switch to STOP.
2. Lift the drawer handle and slide the disk storage drawer open.
3. Select the pack to be mounted as indicated on the program run sheet.



4. Remove the bottom cover of the disk pack by holding the top cover handle with one hand and turning the bottom cover handle counterclockwise with the other hand.



5. Lower the pack on the disk drive.
6. Turn the top cover handle clockwise until the handle is tight.



7. Lift off the top cover.
8. Close the disk storage drawer.
9. Set the START/STOP switch to START. Within two minutes the green ready light (A) comes on and the disk can be used.



### 3340 OPERATOR PANEL

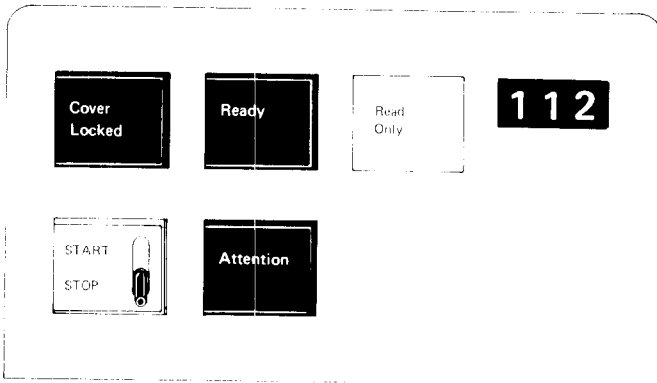

#### READY Indicator

Lights when the data module is properly inserted and ready for operation.

#### START/STOP Switch

With the switch set to START, the cover is locked, the data module is loaded and the heads are moved to track 0, provided that:

1. The drive power is on.
2. The data module is in place.
3. The cover is closed and latched.

When the switch is set to STOP, the data module unloads and the cover unlocks. The data module cannot unload while the system is communicating with the drive or with a pending ATTENTION.

#### READ ONLY Indicator

Lights when the write function is inhibited after the data module is loaded. Write is inhibited by enabling the read only function on the data module.

#### COVER LOCKED Indicator

Lights when the drive cover is locked.

#### ATTENTION Key

When pressed, the ATTENTION key begins a rezero operation:

1. Read/write heads are moved to track 0.
2. DM (data module) Attention is signaled to the controller.
3. Drive is placed online and CE mode is reset (after maintenance completion).

### 3344 OPERATOR PANEL

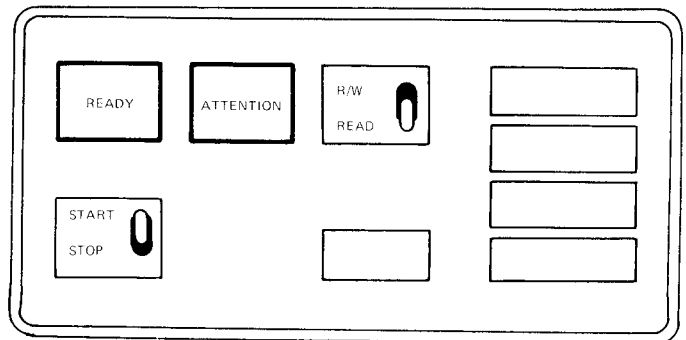

#### READY Lamp

The READY lamp turns on when the drive power is on, the drive speed is up to normal, and the head is on a track.

#### START/STOP Switch

The drive START/STOP switch starts and stops a drive. When set to START, the brake is released, the disks start spinning, and the heads move to cylinder 0. When set to STOP, the heads retract, the brake engages, and the disks stop. An electrical interlock in the stop position prevents a stop if the drive is busy.

#### ATTENTION Key

When pressed, the ATTENTION key starts a rezero operation. Rezero moves the heads to track 0, resets the address registers, and signals attention to the controller.

### R/W or READ Switch

When this switch is in the READ position, no write or erase operation can be done. If set to R/W, all normal operations are possible. If the switch position is changed during an operation, the condition does not change until the operation is completed.

### 3340/3344 POWER PANEL

#### Machines Without String Switch Feature

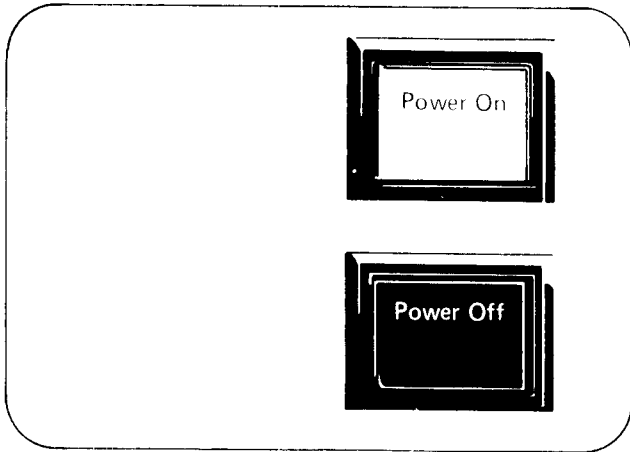

#### POWER ON Switch

Operation of the POWER ON switch allows AC power to be applied to the 3340 or 3344 provided subsystem power is present. The switch is bypassed by the sequencing controls during a system power-up operation.

#### POWER OFF Switch

Operation of the POWER OFF switch removes AC power from the 3340 or 3344 when system power is up. During a system power-down operation, this switch is bypassed and power is removed by the sequencing controls.

*Note:* Do not use POWER ON/POWER OFF switches to load or unload the data module.

### DATA MODULE LOADING

1. Set the START/STOP switch to the STOP position.
2. Open the top cover.

3. With the data module doorway facing the rear of the drive, lower the data module into the drive shroud recess until it is seated.
4. Close the top cover.
5. Set the START/STOP switch to the START position. The COVER LOCKED indicator will light indicating the start of the load sequence.
6. The data module is automatically loaded. After 20 seconds, the READY indicator will light to show the drive is ready. This also forces a pack change device end interrupt to the storage control.

*Note:* Correct data module loading depends on:

- a. Proper data module alignment in the drive shroud recess.
- b. The 3340 top cover being fully closed.
- c. The 3348 Model 70F being used only on drives having the fixed head feature. If the Model 70F is loaded on a drive without the fixed head feature, the READY light indicates ready, but the drive is not online to the system. Intervention Required is set in the sense information.

Fixed head drives can operate with any data module.

*Note:* The fixed head feature is not supported on System/3.

7. If the data module fails to load, the READY indicator does not light. Press the drive Reset switch. If nothing happens, set the START/STOP switch to STOP and press Reset again. If the drive does not respond, call for customer engineer assistance.

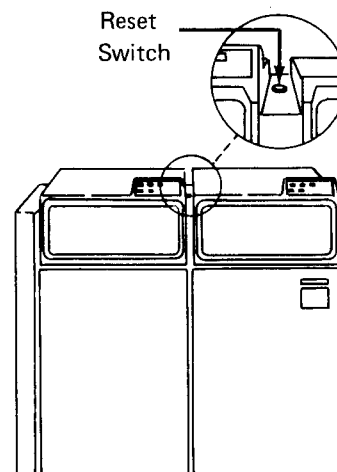

## DATA MODULE UNLOADING

1. Set the START/STOP switch to the STOP position.
2. When the COVER LOCKED indicator turns off, open the top cover.
3. Lift the data module from the drive.

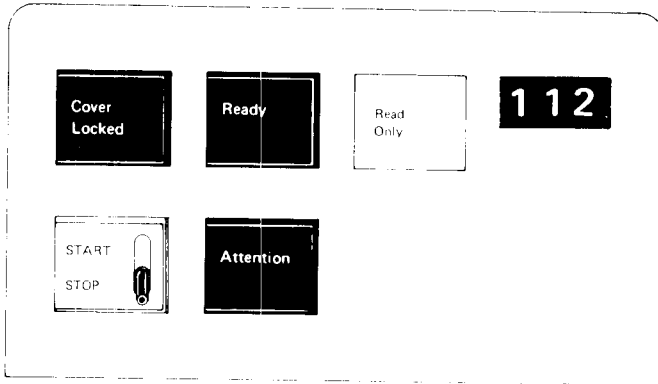

Operator Panel

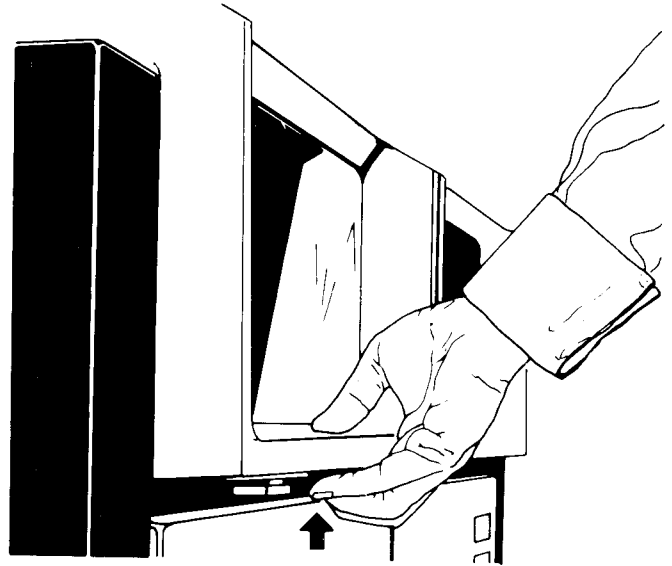

Opening Cover

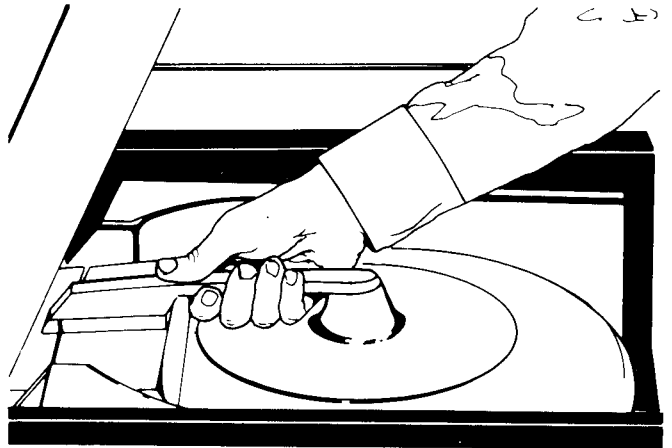

Load/Unload Data Module

## READ ONLY FUNCTION

The Read Only function protects previously written data. On the 3344 units a READ or R/W switch, used for this purpose, is located on the operator panel. In 3340 units the means for protecting data is located on the data module.

### Enable Read Only Function

1. With the data module removed from the drive, press down the IBM logo inset of the handle **A** and **B**.
2. Turn inset 180° and snap into place **C**.
3. The data module may now be loaded in the desired drive.

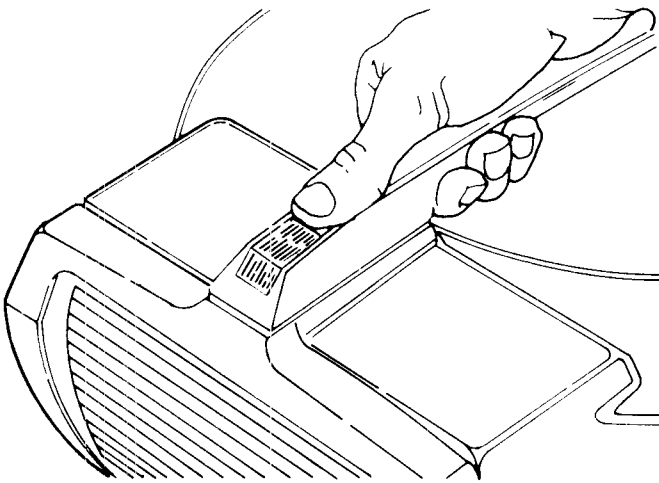

**A** Read/Write

### Disable Read Only Function

1. With the data module removed from the drive, return the IBM logo inset to its original position reverse 180° **D**.
2. The data module may now be loaded into the desired drive.

*Note:* Do not attempt to enable or disable the Read Only function while the data module rests in the drive shroud recess.

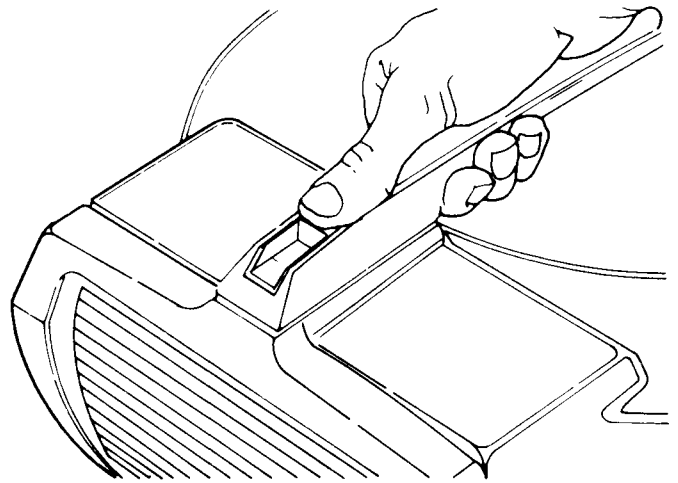

**C** Read Only

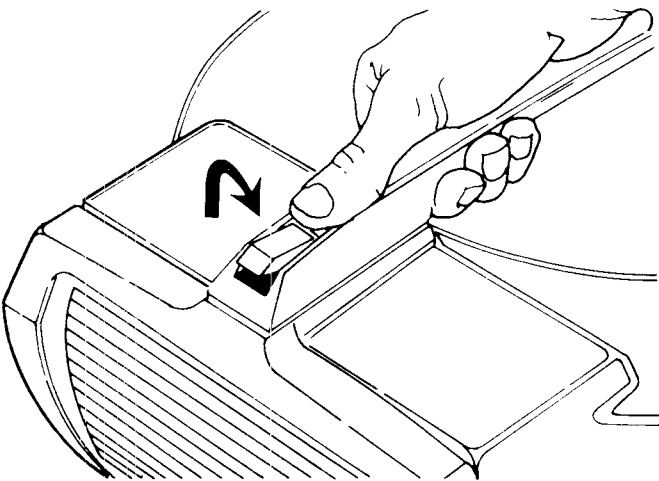

**B** Actuate from Read/Write to Read Only

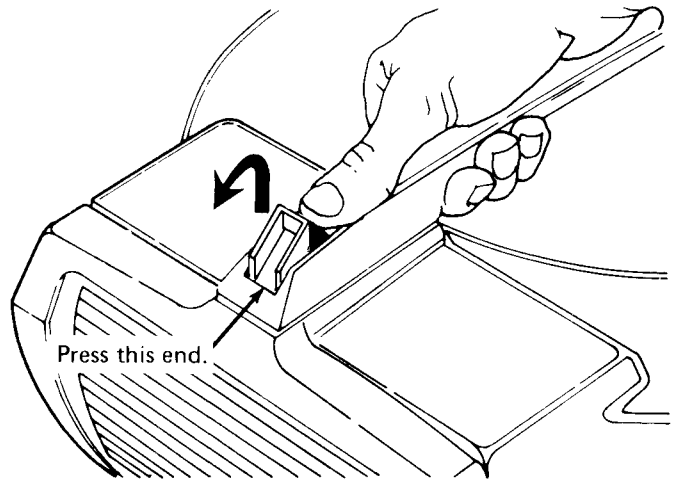

**D** Actuate from Read Only to Read/Write

## **Part 2. System Operation**





## Chapter 14. Preparing the System for Program Operation

- Clearing Cards from the Card Reader
- Placing Forms in the Printer
- Performing IPL
- Clearing I/O Attention

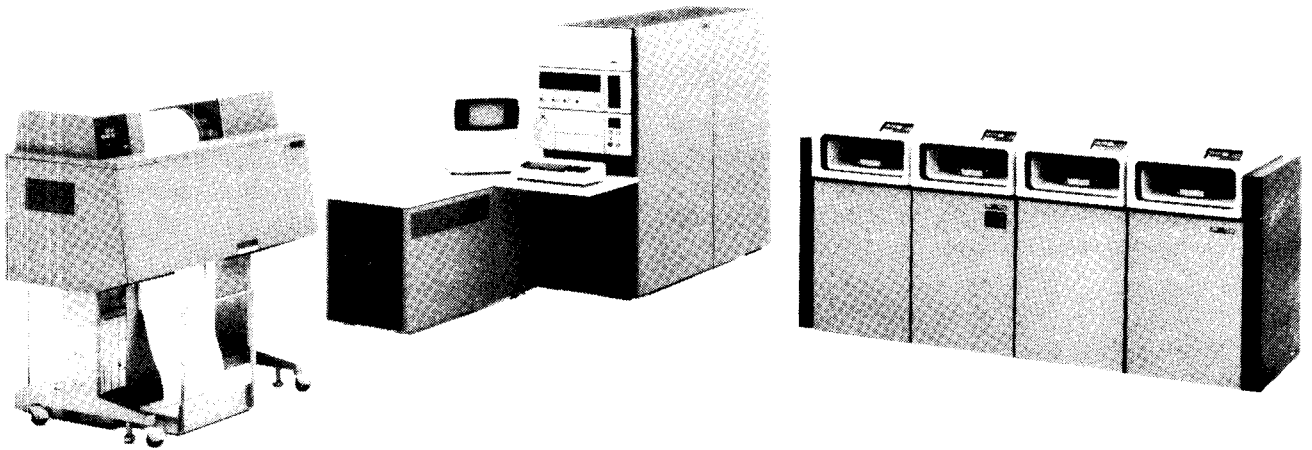

To ready the system for operation, turn on the system POWER switch on the system control panel of the processing unit console.

### CLEARING CARDS FROM THE CARD READER

When power is on, a light on the card reader you are using turns on to indicate that the card reader must be cleared:

Reader	Light
MFCU	NPRO
MFCM	FEED CHECK
1442	CHECK and HOPR
2501	FEED CHECK

To turn the light off and to clear the card reader:

1. Remove cards from the hoppers.
2. Press NPRO (twice if the reader is the MFCU).
3. Remove cards from the stackers.

### PLACING FORMS IN THE PRINTER

To have the system ready for program operation, you need forms in the printer. If you have not aligned the forms in the printer, do it now. See *Chapter 7. IBM 1403 Printer, Models 2 and 5* or *Chapter 8. IBM 1403 Printer, Model N1* to see how to load and align forms.

### PERFORMING IPL

The IPL process can be initiated from the card reader, the fixed (F1) disk on the 5444 drive 1 or the removable (R1) disk on the 5444 drive 1 if these devices are supported. IPL cannot be initiated from the 5444 drive 2.

For systems using only the 3340 Direct Access Storage Facility, the disk resident system from which you can perform the IPL process must reside on the simulation area that corresponds to F1 or the simulation area that corresponds to R1 on drive 1 (D1). If your system uses 3340 Direct Access Storage Facility and 3344 Direct Access Storage, the disk resident system from which you can perform the IPL process may reside on drive 3 (D3).

If you need to initiate the IPL process from the card reader, the program run sheet supplied by the programmer indicates this. The procedures for how to perform IPL from the card reader are given later in this chapter.

### IPL From Disk (5444, 3340, or 3344)

When you perform the IPL process from disk (5444, 3340, or 3344), the system issues a prompt requesting the system date. The date you provide in response to this prompt is also used as the program partition date. If the interval timer is specified during system generation, the system date is automatically updated to the next date when the interval timer passes 23:59:59. The partition date is reset to the system date when the partition is started.

If you do not enter the system date during the IPL process, the system date must be supplied before any jobs are initiated. The date is supplied to the system by way of a DATE OCL statement or via the DATE command. For more information on the DATE OCL statement, see *Chapter 18. Operation Control Language (OCL) Overview*; for information on the DATE command, see *Chapter 15. Using Operator Control Commands (OCC)*.

When IPL is complete, a message indicating the device from which IPL was performed is displayed on the CRT screen until you respond to the message to start a job. If you respond to the message but have not readied the input devices, another message is displayed on the CRT screen indicating that an I/O device must be made ready. This message remains until the appropriate input devices are ready. When the I/O devices are ready, you must respond to the message to begin executing the job.

The following procedures must be performed each time you initiate the IPL process from the fixed or removable disk:

1. When your resident system disk is on the proper device (R1, F1, D1, or D3), set the appropriate START/STOP switch to START.
2. Set the PROGRAM LOAD SELECTOR at FIXED DISK or REMOVABLE DISK for the 5444 or DISK 1 F1 or DISK 1 R1 for the 3340 or DISK 3 F1 or DISK 3 R1 for the 3344.
3. When the READY light for the disk is on, press PROGRAM LOAD.

While IPL is in process, the disk ATTENTION key should not be pressed nor should the disk drives be in the process of powering on (becoming ready).

*Note:* IPL process time may vary depending on whether system transient addresses must be resolved.

During the IPL process, the following prompt occurs:

**ENTER SYSTEM DATE**

You can respond in one of two ways:

1. Key in the date in the format chosen during system generation on line 8 overlaying the minus sign, and press ENTER.
2. Ignore the prompt by pressing ENTER. If you choose to ignore the prompt, you must enter the date via the DATE OCL statement or the DATE command before initiating the first job. When the IPL process is complete, the display shown in Figure 38 appears on the CRT screen.

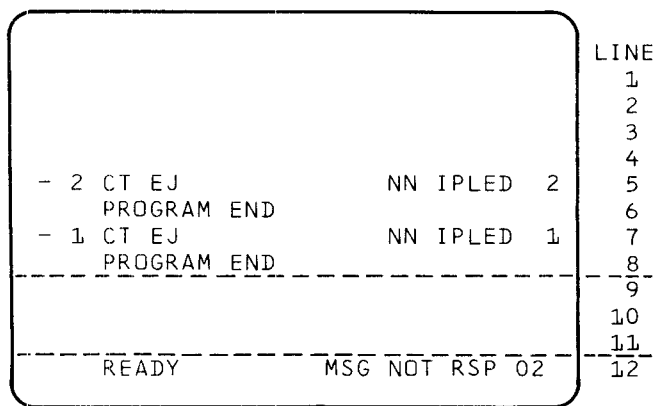

*Note:* NN may be F1 or R1 and indicates the device from which IPL was performed (5704-SC1 only).

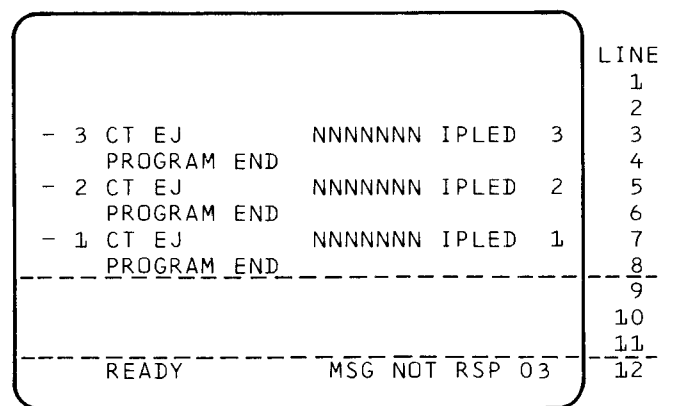

*Note:* NNNNNNN may be F1 (D1A), R1 (D1B), F1 (D3A), or R1 (D3B) and indicates the device from which IPL was performed (5704-SC2 only).

**Figure 38. CRT Display at End of IPL**

## IPL From the Card Reader

Programs that require you to initiate the IPL process from a card reader are indicated on the program run sheet. These are known as stand-alone programs. Perform the following procedure to initiate the IPL process from a card reader.

1. Place the cards for the job in the hopper of the card reader (primary hopper for the MFCU or MFCM).
2. Press START on the reader.
3. Set PROGRAM LOAD SELECTOR to ALTERNATE.
4. Press PROGRAM LOAD.

Cards in the hopper are read into storage and the program is executed.

**Note:** If a read check or feed check occurs while the IPL process cards are being read, clear the cards from the hopper, press NPRO, and restart the IPL procedure.

To continue with normal system operation, initiate the IPL process from the fixed or removable disk after completion of the stand-alone programs.

## Initiating Program Execution

Figure 39 shows the steps required to load and run a program on the Model 15. The information you need to run the program can come from two sources, the system or the programmer:

1. The system informs you of error conditions or special operating instructions by a displayed or printed message or both:
  - a. An I/O attention message means an I/O (input/output) device is not ready. See *Clearing I/O Attention* in this chapter.
  - b. Most programmed messages are displayed on the CRT screen and described in the *IBM System/3 Model 15 System Messages*, GC21-5076.
2. The programmer gives you special instructions on the program run sheet.

## CLEARING I/O ATTENTION

When a device is selected by a program and that device is not ready, a message is displayed on the CRT screen. The indication on the device guides you to the cause of the not-ready condition. The program will not continue until you ready the device and respond to the message. Conditions that can cause an I/O attention, along with recovery procedures, are listed in Figure 40.

Several I/O devices use the unit record restart function. When you press the START key on these devices, you eliminate the need to take a 1 option response to certain messages. If two or more of the I/O devices become not ready at the same time, restart the devices by pressing the START key on each device in the following order depending on the System Control Program (SCP) you have:

### SCP 5704-SC1

1442 Card Read Punch  
2501 Card Reader  
5424 MFCU  
2560 MFCM  
1403 Printer

### SCP 5704-SC2

2501 Card Reader  
1442 Card Read Punch  
5424 MFCU  
2560 MFCM  
1403 Printer

SCP 5704-SC2 also supports the unit record restart function for the directly attached 3741 Data Station/Programmable Work Station and the second 1403 Printer; these devices may be restarted in any order.

The volume recognition facility for systems using Program Number 5704-SC2 also eliminates the need to take a 1 option response to certain 3340 or 3344 I/O messages. The *IBM System/3 Model 15 System Messages*, GC21-5076, identifies the messages that apply to the unit record restart function.

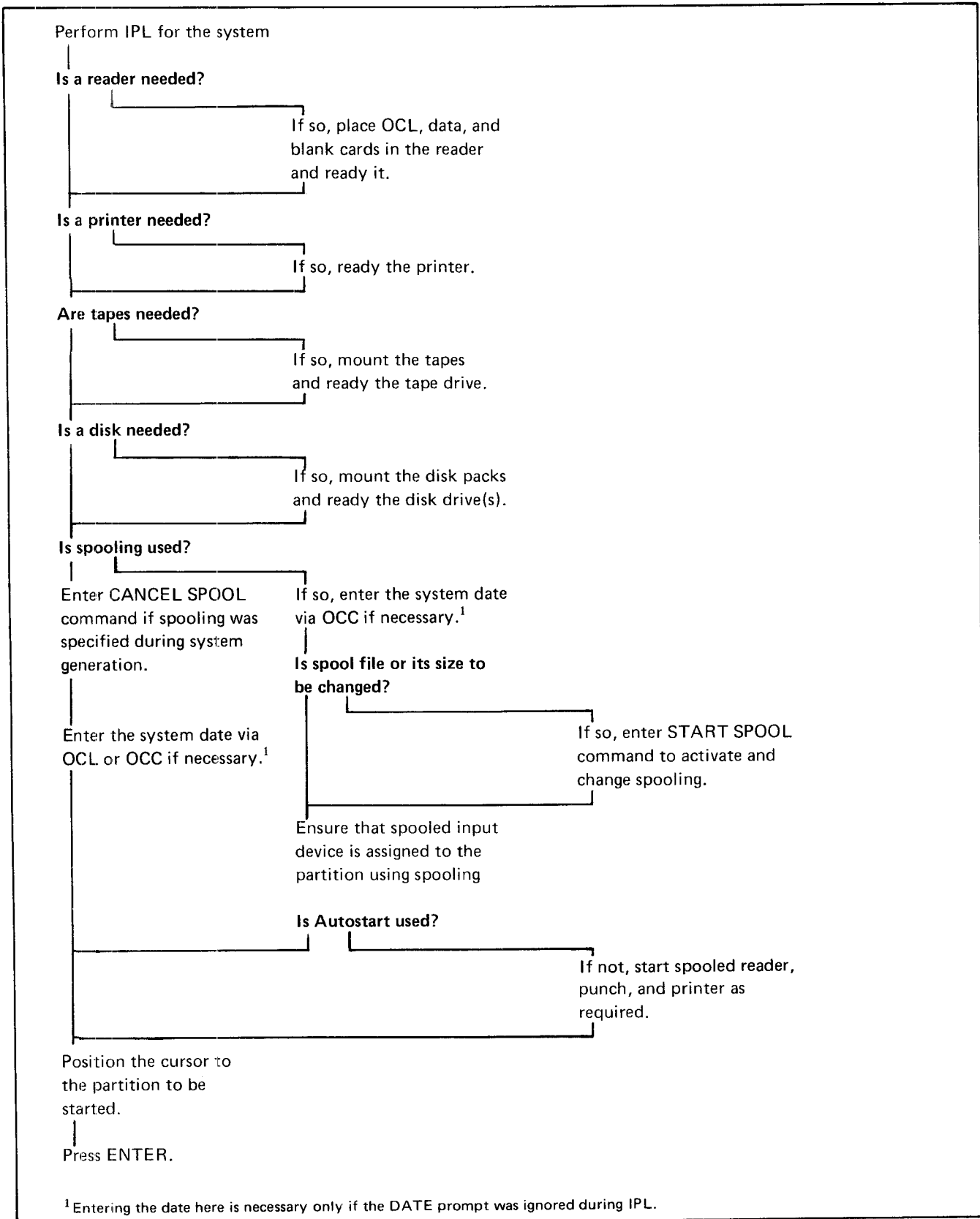

Figure 39. Summary of System Operating Procedures

Device	Device Indicator On	Cause	How To Clear
Printer	None	Printer not ready	Press printer START.
	PRINT CHECK	Hardware malfunction.	Press CHECK RESET and printer START.
	END OF FORM	Forms end.	Load forms and press printer START.
	FORMS CHECK	Forms jam.	Clear jam and press printer START.
	SYNC CHECK	1. Forms out of position. 2. Hardware malfunction.	1. Reposition forms. Press CHECK RESET and printer START. 2. Press CHECK RESET and printer START.
MFCU	None	MFCU not ready.	Ensure proper cards are in hoppers. Press MFCU START.
	STKR	A stacker is full.	Empty stacker and press MFCU START.
	CHIP	Chip box is full or not in the machine.	Empty chip box and press MFCU START.
	CVR	MFCU top cover is open or not latched.	Close the cover and press MFCU START.
MFCM	None	MFCM not ready.	Ensure proper cards are in hoppers. Press MFCM START.
	ATTENTION	1. Stacker is full. 2. Machine cover is open. 3. Chip box is full. 4. Print interlock arm is not locked. 5. Hand wheel is engaged.	1. Empty stacker and press MFCM START. 2. Close cover and press MFCM START. 3. Empty chip box and press MFCM START. 4. Lock arm in place and press MFCM START. 5. Call IBM for hardware support.
	FEED CHECK	1. Card jam. 2. Machine cover is open. 3. Hardware malfunction.	1. Clear jam. Press MFCM NPRO and MFCM START. 2. Close cover and press MFCM START. 3. Press MFCM NPRO and MFCM START.
	READ CHECK	Invalid code detected.	Remove all cards from hopper. Press MFCM NPRO and MFCM START.
	PUNCH CHECK	Error in output.	Remove all cards from hopper. Press MFCM NPRO and MFCM START.

Figure 40 (Part 1 of 2). Clearing I/O Attention

Device	Device Indicator On	Cause	How To Clear
1442	None	1442 not ready: <ol style="list-style-type: none"> <li>No cards in hopper.</li> <li>Last card sequence.</li> <li>1442 STOP pressed.</li> <li>Stacker full.</li> <li>Top cover open or not latched.</li> </ol>	<ol style="list-style-type: none"> <li>Load cards in hopper and press 1442 START.</li> <li>Place more cards in hopper, if available. Press 1442 START.</li> <li>Press 1442 START.</li> <li>Empty stacker and press 1442 START.</li> <li>Close the cover and press 1442 START.</li> </ol>
	CHIP BOX	Chip box is full or not in machine.	Empty the chip box and press 1442 START.
2501	None	2501 not ready.	Press 2501 START.
	ATTENTION	<ol style="list-style-type: none"> <li>Cover is open.</li> <li>Stacker is full.</li> </ol>	<ol style="list-style-type: none"> <li>Close the cover and press 2501 START.</li> <li>Empty stacker and press 2501 START.</li> </ol>
	READ CHECK	Card jam.	Clear jam. Press 2501 NPRO and 2501 START.
	FEED CHECK	Card jam.	Clear jam. Press 2501 NPRO and 2501 START.
Disk	None	Disk not up to speed.	Wait for READY light to turn on.
Tape	FILE PROTECT	Tape unit not ready: <ol style="list-style-type: none"> <li>Cover not closed.</li> <li>Tape not mounted properly.</li> <li>Tape multivolume processing and the next volume is not available.</li> </ol>	<ol style="list-style-type: none"> <li>Close cover and press RESET, LOAD REWIND, and tape START.</li> <li>See procedures for tape mounting.</li> <li>Mount the next volume in the multivolume file.</li> </ol>
BSCA	BSCA ATTN	<ol style="list-style-type: none"> <li>Data set is not ready.</li> <li>Autocall unit power is off.</li> <li>BSCA is disabled.</li> <li>External test switch is on TEST and BSCA is not in the test mode.</li> </ol>	<ol style="list-style-type: none"> <li>Place call.</li> <li>Turn autocall unit power on.</li> <li>Place call.</li> <li>Wait for BSCA ATTN light to turn off, then place call.</li> </ol>

Figure 40 (Part 2 of 2). Clearing I/O Attention





## Chapter 15. Using Operator Control Commands (OCC)

- Entering OCC
- Operator Control Commands

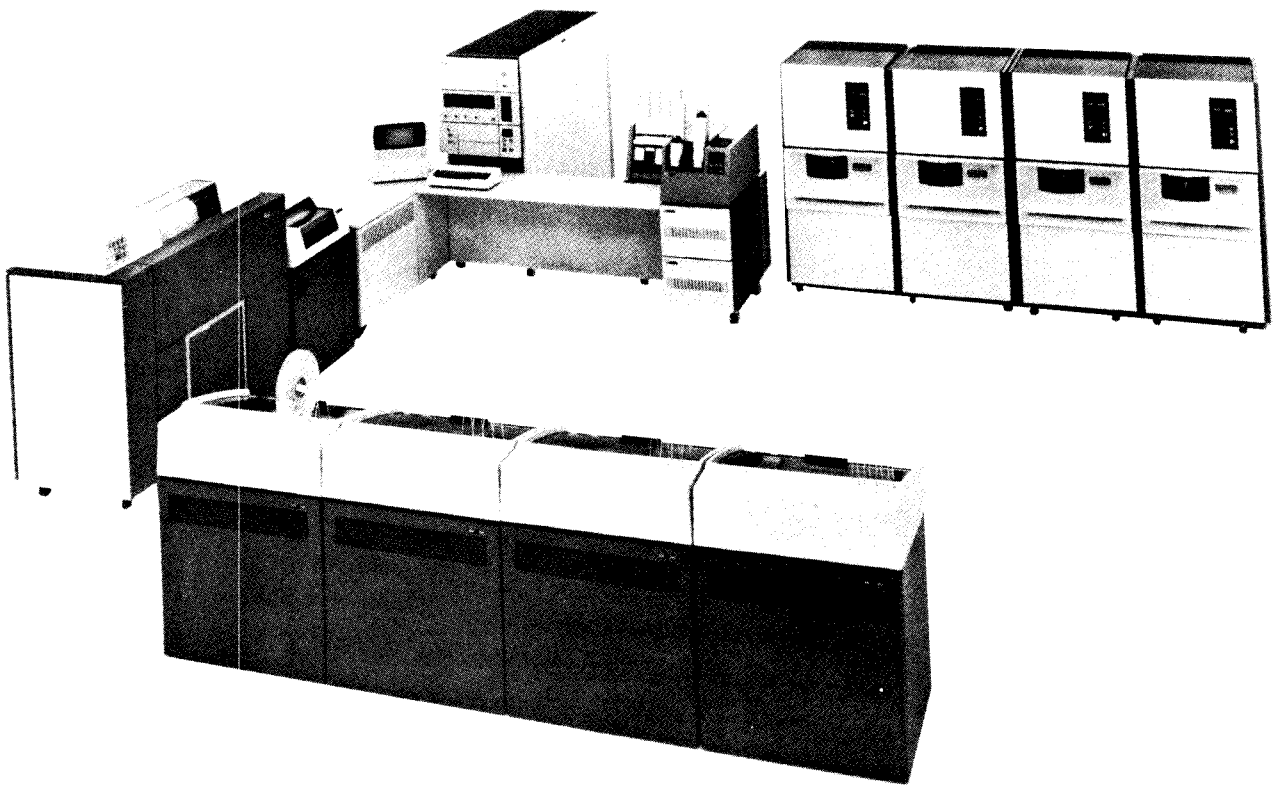

Operator control commands (OCC) are one of the ways you can communicate with the system before, during, or after program execution. Some OCCs can be used only to control spooling; some control only nonspooling functions, and others control either, depending on the operands specified.

The following functions are provided by OCC:

- Canceling a job that is executing in a partition, spool during IPL, a job or job step from a spool queue, or the entire queue.
- Establishing the system date.
- Displaying the system status, system history area, or the spool queues on the CRT screen.
- Dumping storage for a partition or for the entire system.
- Temporarily suspending processing in a partition.
- Controlling the deletion of I-type messages from the response queue.
- Changing the main storage requirements, number of output copies, card type, forms type, partition assignment, or priority of a job or job step on the spool queues.
- Assigning the system input device for a partition.
- Interrupting an executing program to load and execute another (5704-SC1 only).
- Requesting an informal message when the system history area is almost full.
- Controlling partition size.
- Allowing 5444 simulation to be enabled or disabled on a system equipped with a 3340 (5704-SC1 only).
- Establishing the time of day.
- Starting and stopping a program executing in a partition.
- Starting the spooling routines, spooling in a partition, or spooling during an IPL.
- Stopping the spooling routines or spooling in a partition (5704-SC2 only).
- Restarting the spool print or punch writers.

- Holding a job, job step, or the entire spool queue.
- Releasing a job, job step, or the entire spool queue.
- Freeing space in the spool file from the currently printing or punching job step (5704-SC2 only).

## ENTERING OCC

1. Press the PF10 key on the 3277 keyboard.
2. When ENTER COMMAND is displayed on the screen, enter the OCC via the keyboard. The command you enter is displayed on the CRT screen. OCC are free-form and must meet only the following restrictions:
  - a. One or more blanks must separate the operation and the operands.
  - b. If more than one operand is used, they must be separated by a comma and no blanks.
  - c. The length of the command must not exceed 40 characters (one line on the CRT).
  - d. No characters may be entered after the last operand.
  - e. Comments may be entered by placing an asterisk in position 1 (5704-SC2 only). The special comment '\*TIME comment' can be used to place a time stamp directly following the special comment in the system history area.
3. Press the ENTER key on the keyboard.
4. OCC entry is allowed while in display format (5704-SC2 only).

*Note:* The message CAN NOT ACCEPT may be displayed after an OCC has been entered. For a description of why the command was not accepted, see the explanation of the command later in this chapter. If none of the reasons apply, reenter the command.

## OPERATOR CONTROL COMMANDS

The following conventions are used to illustrate the commands:

1. Uppercase letters and punctuation marks (except as described in items 3 and 4) must be entered exactly as shown.
2. Lowercase letters and terms represent variable information you supply depending on the operation you want performed.
3. Items in brackets [ ] are optional. You include or omit these items as required by the operation.
4. Items in braces { } indicate alternatives. You must enter one of the items.
5. Optional items that are underlined indicate the default value. If none of the items are entered, the default value is used.
6. Abbreviations, if applicable, are enclosed in parentheses ( ) below the operation or operand. These abbreviations can be entered in place of the keywords.
7. All operands are positional. Operands must be entered in the order shown. If any operand except the last is omitted, a comma must be entered in its place.

A summary of the OCC is provided in *Appendix E. Operator Control Commands (OCC) Summary*.

*Note:* For information about changing the system default values at IPL of some of the OCC commands with the \$CNFIG program, see *IBM System/3 Model 15 System Control Programming Concepts and Reference Manual*, GC21-5162.

## CANCEL Command

### Functions

- This command takes effect immediately.
- Cancels spooling.
- Cancels the reader queue or one or more jobs on the reader queue.
- Cancels the print queue, one or more jobs on the print queue, or one or more job steps on the print queue.
- Cancels the punch queue, one or more jobs on the punch queue, or one or more job steps on the punch queue.

*Note:* The preceding functions are valid only for systems that support spooling.

- Cancels a program that is executing in a partition.

### Format

Operation	Operand
CANCEL (CN)	SPOOL (SP)
	RDRQ, { jobname } (RQ) { characters** }
	PRTQ, { jobname } [ ,stepname ] (WQ) { characters** } [ ,characters** ]
	PCHQ, { jobname } [ ,stepname ] (PQ) { characters** } [ ,characters** ]
	*RDRQ (*RQ)
	*PRTQ (*WQ)
	*PCHQ (*PQ)
	P1 [ $\begin{matrix} 2 \\ . \\ 3 \end{matrix}$ ]
	P2 [ $\begin{matrix} 2 \\ . \\ 3 \end{matrix}$ ]
	P3 [ $\begin{matrix} 2 \\ . \\ 3 \end{matrix}$ ]

## CANCEL Command (Continued)

### Contents

*SPOOL (SP)*: This operand can be specified at IPL prior to spooling being activated. The main storage used by the spooling routine is made available to any partition. (For a partition to use this additional main storage, a SET command must be entered.) IPL must be performed again to activate spooling. Once spooling is activated, it cannot be canceled.

*RDRQ (RQ)*: This operand specifies the queue that contains the job to which the cancel applies.

The jobname operand specifies the job that is canceled from the reader queue. The RDRQ operand is valid only on systems that support input spooling.

*PRTQ (WQ)*: This operand specifies the queue that contains the job or job step to which the cancel applies.

When the jobname operand is used, all steps of the specified job are canceled from the print queue. When both the jobname and stepname are used, only the specified step is canceled. If the job or step you want to cancel is currently being printed, it is terminated immediately; and the next step on the queue is processed.

*PCHQ (PQ)*: This operand specifies the queue that contains the job or job step to which the cancel applies.

When the jobname operand is used, all steps of the specified job are canceled from the punch queue. When both the jobname and stepname are used, only the specified step is canceled. If the job or step you want to cancel is currently being punched, it is terminated immediately; and the next step on the queue is processed. The PCHQ operand is valid only on systems that support punch spooling.

*\*RDRQ (\*RQ)*: This operand cancels the entire reader queue but does not affect the job currently executing or the job currently being placed on the reader queue. The \*RDRQ operand is valid only on systems that support input spooling.

*\*PRTQ (\*WQ)*: This operand cancels the entire print queue but does not affect the job step currently being printed or the output being placed on the queue by an executing program.

*\*PCHQ (\*PQ)*: This operand cancels the entire punch queue but does not affect the job step currently being punched or the output being placed on the queue by an executing program. The \*PCHQ operand is valid only on systems that support punch spooling.

*Note:* \* is part of the command.

## CANCEL Command (Continued)

### Contents (Continued)

*P1, P2, or P3:* This operand cancels the program currently executing in the specified partition (1, 2, or 3). The optional 2 operand causes a controlled cancel to be taken; in this case files in the program are closed. The optional 3 operand causes an immediate cancel. If neither a 2 or 3 is specified, 2 is assumed. The P1, P2, or P3 operand can be used whether or not spooling is supported by the system. P3 is available only for 5704-SC2.

*jobname:* This operand specifies the job to which the cancel applies.

*stepname:* This operand specifies the job step to which the cancel applies.

*characters\*\* (5704-SC2 only):* This operand specifies the jobs and/or job steps to which the cancel applies. Multiple jobs/steps can be referenced by specifying one to seven characters followed by two asterisks (\*\*). All jobs/steps on the queue whose names begin with the specified characters will be canceled.

### Considerations

A job executing in a partition cannot be canceled by specifying its name. It can be canceled only by specifying the partition in which it is executing.

Consider the following example:

```
CANCEL PRTQ,JOBA,STEP1  
or  
CN WQ,JOBA,STEP1
```

STEP1 of JOBA on the print queue is removed from the queue.

## **CANCEL Command (Continued)**

### **Considerations (Continued)**

After the CANCEL command for a partition is entered, CAN NOT ACCEPT is displayed if one of the following conditions exists:

- The copy reader-to-library or modify functions of \$MAINT are being used.
- Job initiation or termination is being processed in the specified partition.
- The 2 option is specified but the partition has a message pending that allows only the 3 option.
- Partition 2 or partition 3 is specified but it is set to zero.
- A START SPOOL command (issued at IPL time) has not been completed.

## CHANGE Card Type Command

**Function** Changes the card type characters associated with one or more jobs or job steps on the punch queue. This command is valid only if spooling is active.

Format	Operation	Operand
CHANGE (G)	CRD,card type,	$\left[ \begin{array}{c} \text{PCHQ} \\ \text{(PQ)} \end{array} \right] \left\{ \begin{array}{c} \text{jobname} \\ \text{characters**} \end{array} \right\} \left[ \begin{array}{c} \text{stepname} \\ \text{characters**} \end{array} \right]$

**Contents** *CRD*: This operand indicates a change in the card type characters for a job or job step on the punch queue.

*card type*: This operand may be any combination of one to three characters (except commas or blanks) to indicate the card type used. These characters are examined by the punch writer when punching spooled output. If the card type differs from that of the previous punch step, the system issues a message indicating the card type to be used.

*PCHQ*: This operand specifies the queue that contains the job to which the change in the card type applies. Since only the punch queue is valid for this function, the queue operand can be omitted as shown in the following example:

```
CHANGE CRD,ABC,,JOB1,STEP1
```

*jobname*: This operand specifies the job to which the change of card type applies.

*stepname*: This operand specifies the job step to which the change of card type applies.

*characters\*\* (5704-SC2 only)*: This operand specifies the jobs and/or job steps to which the change of card type applies. Multiple jobs/steps can be referenced by specifying one to seven characters followed by two asterisks(\*\*). All jobs/steps on the queue whose names begin with the specified characters will have the card type changed.

**Considerations** Unless the CHANGE card type command specifies stepname, all job steps within a job on the punch queue receive the change.

The CHANGE card type command does not affect a punch step that is currently punching.



## CHANGE Copies Command

**Function** Changes the number of output copies produced by one or more jobs on an output queue. This command is valid only if spooling is active.

Format	Operation	Operand
CHANGE (G)	CPY,[number],	$\left. \begin{array}{l} \text{PRTQ} \\ \text{(WQ)} \\ \text{PCHQ} \\ \text{(PQ)} \end{array} \right\} \cdot \left\{ \begin{array}{l} \text{jobname} \\ \text{characters**} \end{array} \right\} \left[ \begin{array}{l} \text{,stepname} \\ \text{,characters**} \end{array} \right]$

**Contents** *CPY*: This operand indicates a change in the number of copies produced by a job on the output queue.

*number*: This operand specifies the number (1-99) of output copies to be produced by the job or job step. If the number of copies is altered while the job step is being punched or printed, the total number of copies produced is the sum of the new number and the number of copies already completed. A default value of one copy is assumed if the operand is not specified.

*PRTQ or PCHQ*: This operand specifies the queue that contains the job or job step to which the change in the number of copies applies.

*jobname*: This operand specifies the job to which the change in the number of copies applies.

*stepname*: This operand specifies the job step to which the change in the number of copies applies.

*characters\*\* (5704-SC2 only)*: This operand specifies the jobs and/or job steps to which the change in the number of copies applies. Multiple jobs/steps can be referenced by specifying one to seven characters followed by two asterisks (\*\*). All jobs/steps on the queue whose names begin with the specified characters will have the number of copies changed.

**Considerations** Unless the CHANGE copies command specifies stepname, all job steps within a job on the output queue receive the change.

## CHANGE Core Command

**Function** Changes the amount of main storage required for one or more jobs on the reader queue. This command is valid only if spooling is active.

Format	Operation	Operand
CHANGE (G)		CORE,size, $\left[ \begin{array}{c} \text{RDRO} \\ \text{(RQ)} \end{array} \right]$ , { jobname characters** }

**Contents** *CORE*: This operand indicates that a job on the reader queue is to have its main storage size requirements changed.

*size*: This operand specifies the amount of main storage required to execute the largest step in the job. (It does not assign main storage to the partition; the SET command must be used for this purpose.) The number (one to three digits) specified can range from 0 to 238K (5704-SC1 only) or from 0 to 488K (5704-SC2 only). If 0 is specified, the current partition size is assumed.

*RDRO*: This operand specifies the queue that contains the job to which the change applies. Since only the reader queue is valid for this command, this operand can be omitted as shown in the following example:

```
CHANGE CORE,8,,SAMPLE
```

*jobname*: This operand specifies the job to which the change of main storage size applies.

*characters\*\* (5704-SC2 only)*: This operand specifies the jobs to which the change of main storage size applies. Multiple jobs can be referenced by specifying one to seven characters followed by two asterisks (\*\*). All jobs on the queue whose names begin with the specified characters will have the storage requirement changed.

**Considerations** You cannot specify stepname to change main storage requirements; jobs on the reader queue can be controlled only on a job basis. If the JOB statement for the job to be changed is in error, the change is not allowed.

## CHANGE Forms Type Command

<b>Function</b>	Changes the forms type characters associated with one or more jobs or job steps on the print queue. This command is valid only if spooling is active.	
<b>Format</b>	<b>Operation</b>	<b>Operand</b>
	CHANGE (G)	FRM,forms type, $\left[ \begin{array}{l} \text{PRTQ} \\ \text{(WQ)} \end{array} \right] \left\{ \begin{array}{l} \text{jobname} \\ \text{characters}^{**} \end{array} \right\} \left[ \begin{array}{l} \text{,stepname} \\ \text{,characters}^{**} \end{array} \right]$

**Contents**

*FRM*: This operand indicates a change in the forms type characters for a job or job step on the print queue.

*forms type*: This operand can be any combination of one to three characters (except commas or blanks) to indicate the forms type used. These characters are examined by the print writer when printing spooled output. If the forms type for the current print step is different from that of the previous print step, the system issues a message indicating the forms type to be used. The response taken to this message determines whether separator pages are to be printed between print steps.

*PRTQ*: This operand specifies the queue that contains the job to which the change in the forms type applies. Since only the print queue is valid for this function, the queue operand can be omitted as shown in the following example:

```
CHANGE FRM,ABC,,JOB1,STEP1
```

*jobname*: This operand specifies the job to which the change of forms type applies.

*stepname*: This operand specifies the job step to which the change of forms type applies.

*characters\*\* (5704-SC2 only)*: This operand specifies the jobs and/or job steps to which the change of forms type applies. Multiple jobs/steps can be referenced by specifying one to seven characters followed by two asterisks (\*\*). All jobs/steps on the queue whose names begin with the specified characters will have the forms type changed.

**Considerations**

Unless the CHANGE forms type command specifies stepname, all job steps within a job on the print queue receive the change.

The CHANGE forms type command does not affect a print step that is currently printing.

## CHANGE Partition Command

**Function** Changes the partition assignment of one or more jobs on the reader queue. This command is valid only if spooling is active.

Format	Operation	Operand
CHANGE (G)	PTN,	$\left[ \begin{array}{c} 1 \\ 2 \\ 3 \\ A \\ B \\ C \\ D \end{array} \right], \left[ \begin{array}{c} \text{RDRQ} \\ \text{(RQ)} \end{array} \right], \left\{ \begin{array}{l} \text{jobname} \\ \text{characters**} \end{array} \right\}$

**Contents** *PTN*: This operand indicates that the partition assignment for a job on the reader queue is to be changed.

$\left[ \begin{array}{c} 1 \\ 2 \\ 3 \\ A \\ B \\ C \\ D \end{array} \right]$	<p>This operand indicates the partition to which the job will be assigned for execution:</p> <ul style="list-style-type: none"> <li>1 Partition 1</li> <li>2 Partition 2</li> <li>3 Partition 3</li> <li>A Partition 1 or 2</li> <li>B Partition 1 or 3</li> <li>C Partition 2 or 3</li> <li>D Partition 1, 2, or 3</li> </ul>
---	--

If A, B, C, or D is used, spool allows a job to be executed in whichever of the specified partitions next requests a job for execution.

*RDRQ*: This operand specifies the queue to which the change applies. Since only the reader queue is valid for this command, the queue operand can be omitted as shown in the following example:

CHANGE PTN,2,,SAMPLE

*jobname*: This operand specifies the job to which the change of partition assignment applies.

*characters\*\* (5704-SC2 only)*: This operand specifies the jobs to which the change of partition assignment applies. Multiple jobs can be referenced by specifying one to seven characters followed by two asterisks (\*\*). All jobs on the queue whose names begin with the specified characters will have the partition assignment changed.

**Considerations** You cannot specify stepname to change partition; jobs on the reader queue can be controlled only on a jobname basis. If the JOB statement for the job to be changed is in error, the change is not allowed.

## CHANGE Priority Command

### Function

Changes the priority of one or more jobs or job steps on a queue. This command is valid only if spooling is active.

### Format

#### Operation

#### Operand

CHANGE (G)	1	}	RDRQ, (RQ)	{ jobname characters** }			
	2						
	3		}	PRTQ, (WQ)	{ jobname characters** }	[,stepname ,characters**]	
	4						
	5					PCHQ, (PQ)	{ jobname characters** }

### Contents

*PTY (Y)*: This operand indicates that the priority of a job or job step on one of the queues is to be changed.

*1, 2, 3, 4, or 5*: This operand is the number of the priority to be assigned to the job or step. The highest priority is 5.

*RDRQ (RQ)*: This operand indicates that the reader queue contains the job for which the priority is to be changed. The jobname parameter identifies the specific job. If the priority of a job on the reader queue is changed, the output from that job has the changed priority assigned to it unless the job steps within the job contain a PRIORITY parameter on a PRINTER or PUNCH statement.

*PRTQ (WQ)*: This operand indicates that the print queue contains the job or step for which the priority is to be changed. When only the jobname parameter is used, the priority of all steps in the job is changed to the same value. When both jobname and stepname parameters are used, the priority of only the specified step is changed.

*PCHQ (PQ)*: This operand indicates that the punch queue contains the job or step for which the priority is to be changed. When only the jobname parameter is used, the priority of all steps in the job is changed to the same value. When both jobname and stepname parameters are used, the priority of only the specified step is changed.

*jobname*: This operand specifies the job to which the change of priority applies.

*stepname*: This operand specifies the job step to which the change of priority applies.

*characters\*\* (5704-SC2 only)*: This operand specifies the jobs and/or job steps to which the change of priority applies. Multiple jobs/steps can be referenced by specifying one to seven characters followed by two asterisks (\*\*). All jobs/steps on the queue whose names begin with the specified characters will have the priority changed.

## CHANGE Priority Command (Continued)

### Considerations

All jobs or job steps are removed from the queue on a first-in, first-out basis within priority. When the priority is changed, the job or step is removed from the queue only after all other jobs (or steps) with the same priority have been removed.

Consider the following example:

```
CHANGE PTY,5,RDRQ,JOBA  
or  
G Y,5,RQ,JOBA
```

Assuming the priority of JOBA was 1, it is changed to 5 and scheduled for execution after all preceding priority 5 jobs had been executed. Output on the print or punch queues for JOBA is also changed from 1 to 5 unless the job steps within JOBA contain the PRIORITY parameter on a PRINTER or PUNCH statement.

## DATE Command

**Function** Sets the system date. When the DATE prompt is ignored during the IPL process, the DATE command may be used in place of a DATE OCL statement.

<b>Format</b>	<b>Operation</b>	<b>Operand</b>
	DATE (DT)	$\left. \begin{array}{l} \text{mm/dd/yy} \\ \text{mmddy} \\ \text{dd/mm/yy} \\ \text{ddmmyy} \end{array} \right\}$

**Contents**

- mm - month
- dd - day
- yy - year

**Considerations**

When the DATE command is entered, all partitions must be at end of job and a rollin cannot be pending. Otherwise, CAN NOT ACCEPT is displayed. The data can be entered in either of the two formats shown, with or without punctuation. Any characters except commas, numbers, or blanks can be used for punctuation. Month, day, and year must be two digits in length; however, leading zeros in month and day can be omitted when punctuation is used. The date format (mm/dd/yy or dd/mm/yy) is set at system generation time.

**This page is intentionally left blank.**



## DISPLAY Command

### Function

- Displays system status information.
- Displays the history of the entire system.
- Displays the history of one to seven tasks (5704-SC2 only).
- Displays the reader, print, and punch queues.

### Format

#### Operation

#### Operand

DISPLAY (D)	[ <table border="0" style="display: inline-table; vertical-align: middle;"> <tr> <td style="padding-right: 5px;">STATUS</td> <td style="border-left: 1px solid black; border-right: 1px solid black; padding: 0 5px;">                             ,P1                              ,P2                              ,P3                              N                         </td> <td style="padding-left: 5px;">]</td> </tr> <tr> <td style="padding-right: 5px;">HISTORY</td> <td style="border-left: 1px solid black; border-right: 1px solid black; padding: 0 5px;">                             [,task]                         </td> <td style="padding-left: 5px;">[,task] ...</td> </tr> </table> (H) RDRQ (RQ) PRTQ (WQ) PCHQ (PQ)	STATUS	,P1 ,P2 ,P3 N	]	HISTORY	[,task]	[,task] ...
STATUS	,P1 ,P2 ,P3 N	]					
HISTORY	[,task]	[,task] ...					

### Contents

*STATUS:* When this operand is specified (or if no operand is specified), the status of the system is displayed on the CRT as follows:

*Note:* The optional entries (,P1 ,P2 ,P3 ,N) are supported by program number 5704-SC2 only.

DISPLAY Command (Continued)

Contents (Continued)

SCP 5704-SC1:

C----- SYSTEM STATUS DISPLAY (P1,P2,SP)	LINE
PART1- <i>nnnK</i> ,RI            PART2- <i>nnnK</i>	1
<i>jobname</i> <i>stepname</i> <i>jobname</i> <i>stepname</i>	2
RDR - <i>dddd</i> (SPOOL) RDR - <i>dddd</i> (SPOOL)	3
PRT - <i>dddd</i> (SPOOL) PRT - <i>dddd</i> (SPOOL)	4
PCH - <i>dddd</i> (SPOOL) PCH - <i>dddd</i> (SPOOL)	5
<i>nnnK</i> AVAILABLE <i>mm/dd/yy</i> <i>hh:mm:ss</i>	6
----- SPOOL STATUS DISPLAY -----	7
RDR - <i>dddd/status</i> UNIT- <i>uuu</i> ,CYL- <i>nnn</i>	8
PRT - <i>dddd/status</i> TKGP SIZE - <i>nn/aaaa</i>	9
PCH - <i>dddd/status</i> TKGPS AVAIL -- <i>nnnn</i>	10
	11

SCP 5704-SC1:

C----- SYSTEM STATUS DISPLAY (P1,P2,SP)	LINE
PART1- <i>nnnK</i> ,RI            PART2- <i>nnnK</i>	1
<i>jobname</i> <i>stepname</i> <i>jobname</i> <i>stepname</i>	2
RDR - <i>dddd</i> (SPOOL) RDR - <i>dddd</i> (SPOOL)	3
PRT - <i>dddd</i> (SPOOL) PRT - <i>dddd</i> (SPOOL)	4
PCH - <i>dddd</i> (SPOOL) PCH - <i>dddd</i> (SPOOL)	5
<i>nnnK</i> AVAILABLE <i>mm/dd/yy</i> <i>hh:mm:ss</i>	6
----- SPOOL STATUS DISPLAY -----	7
SPOOL NOT ACTIVE	8
	9
	10
	11

SCP 5704-SC2:

----- SYSTEM STATUS DISPLAY -----	LINE
SYSTEM REL <i>nn</i> <i>mm/dd/yy</i> <i>hh:mm:ss</i>	1
	2
	3
TASK PRIORITY-( <i>xx,xx,xx=xx</i> )    SHA- <i>x</i>	4
SHARE AREA- <i>nnK</i>	5
MAX PROG SIZE- <i>nnnK</i>	6
<i>nnnK</i> AVAILABLE	7
----- SPOOL STATUS DISPLAY -----	8
RDR - <i>dddd/status</i> UNIT- <i>uuu</i> ,CYL- <i>nnn</i>	9
PRT - <i>dddd/status</i> TKGP SIZE - <i>nn/aaaa</i>	10
PCH - <i>dddd/status</i> TKGPS AVAIL -- <i>nnnn</i>	11

**DISPLAY Command (Continued)**

**Contents (Continued)**

SCP 5704-SC2:

<pre> ----- SYSTEM STATUS DISPLAY ----- SYSTEM REL nn      mm/dd/yy      hh:mm:ss  TASK PRIORITY-(xx,xx=xx)          SHA-x SHARE AREA-nnK MAX PROG SIZE-nnnK nnnK AVAILABLE ----- SPOOL STATUS DISPLAY ----- SPOOL NOT ACTIVE                 </pre>	<p>LINE</p> <p>1</p> <p>2</p> <p>3</p> <p>4</p> <p>5</p> <p>6</p> <p>7</p> <p>8</p> <p>9</p> <p>10</p> <p>11</p>
--	--

SCP 5704-SC2 displays the status of each partition and the names of all main data areas and simulation areas separately. To move forward through the status display sequence (system, partition 1, partition 2, partition 3, names, system . . .), press ENTER in response to each display; or, to skip forward or backward to a specific display, key the partition number (1, 2, or 3), S (for system), or N (for names) over the cursor and press ENTER. The partition status is displayed as follows:

<pre> ----- SYSTEM STATUS DISPLAY ----- PARTn-nnnK  h  P mm/dd/yy      hh:mm:ss jobname stepname      F1 - ddd RDR - dddd (SPOOL)  R1 - ddd  -SWITCH- PRT - dddd (SPOOL)  F2 - ddd  nnnnnnnn PCH - dddd (SPOOL)  R2 - ddd  ----- SPOOL STATUS DISPLAY ----- RDR - dddd/status  UNIT-uuu,CYL-nnn PRT - dddd/status  TKGP SIZE - nn/aaaa PCH - dddd/status  TKGPS AVAIL -- nnnn                 </pre>	<p>LINE</p> <p>1</p> <p>2</p> <p>3</p> <p>4</p> <p>5</p> <p>6</p> <p>7</p> <p>8</p> <p>9</p> <p>10</p> <p>11</p>
--	--

**DISPLAY Command (Continued)**

**Contents (Continued)**

<pre> ----- SYSTEM STATUS DISPLAY ----- PARTn-<i>nnn</i>K h P <i>mm/dd/yy</i>      <i>hh:mm:ss</i> jobname stepname      F1 - <i>ddd</i> RDR - <i>dddd</i> (SPOOL)  R1 - <i>ddd</i>  -SWITCH- PRT - <i>dddd</i> (SPOOL)  F2 - <i>ddd</i>  <i>nnnnnnnn</i> PCH - <i>dddd</i> (SPOOL)  R2 - <i>ddd</i>  ----- SPOOL STATUS DISPLAY ----- SPOOL NOT ACTIVE                 </pre>	<p>LINE 1 2 3 4 5 6 7 8 9 10 11</p>
--	---

The information on names of areas is updated each time a disk drive becomes ready, so the names displayed are those of the disk packs that were last ready on the respective drives. The format of the display varies, depending on the user's disk drive configuration. The names of areas of a system with 3340 and 3344 disk drives are displayed in a format such as the following:

<pre>           D1-D1D1D1          D2-D2D2D2 1A-F1F1F1 1B-R1R1R1 2A-F2F2F2 2B-R2R2R2 1C-D1CD1C 1D-D1DD1D 2C-D2CD2C 2D-D2DD2D           D3 *31-D31D31*32-D32D32*33-D33D33*34-D34D34 3A-D3AD3A 3B-D3BD3B 3C-D3CD3C 3D-D3DD3D 3E-D3ED3E 3F-D3FD3F 3G-D3GD3G 3H-D3HD3H           D4 *41-D41D41*42-D42D42*43-D43D43*44-D44D44 4A-D4AD4A 4B-D4BD4B 4C-D4CD4C 4D-D4DD4D 4E-D4ED4E 4F-D4FD4F 4G-D4GD4G 4H-D4HD4H                 </pre>	<p>LINE 1 2 3 4 5 6 7 8 9 10 11</p>
---	---

To cancel the system status display for 5704-SC1, press ENTER. To cancel the 5704-SC2 system status displays, key a C over the cursor and press ENTER.

*P1, P2, P3 or N (5704-SC2 only):* This operand specifies the first status to display and bypasses the system status display.

## DISPLAY Command (Continued)

### Contents (Continued)

The following chart provides an explanation of the system status display (5704-SC1):

Line	Characters Displayed	Meaning
1	C	Cancel; if ENTER is pressed, display is canceled.
	SYSTEM STATUS DISPLAY	Identifies information in upper half of display.
	(xx,xx,xx)	Task priority, listed in descending order; for example, P1,P2,SP
2	PART1-nnnK PART2-nnnK	Size of partitions 1 and 2.
	RI	Partition has been rolled out; a rollin is pending.
3	jobname stepname	Identity of jobs running in partitions 1 and 2.
4	RDR – ddddd	Reader, printer, and punch devices assigned to each partition by system generation, OCL statements, or OCC commands.
5	PRT – ddddd	
6	PCH – ddddd	
	(SPOOL)	Displayed if a device is assigned to spooling.
7	nnnK AVAILABLE	Main storage not assigned to partition 1 or 2.
	dd/mm/yy or mm/dd/yy	System date, in format specified during system generation.
8	SPOOL STATUS DISPLAY	Identifies information in lower half of display. Lines 8-11 are blank if spooling is not supported by the system.
9 (10) (11)	RDR – ddddd PRT – ddddd PCH – ddddd	Reader, printer, and punch devices assigned to spooling during system generation.
	/status	Status of the spool queues:  ACT Queue contains jobs or steps to process. EMP Queue is empty. H Queue is held via the HOLD command.
9	UNIT-uuu	Unit containing the disk space used by spool.
	CYL-nnn	Number of cylinders assigned to the spool area during system generation or IPL.
10	TKGP SIZE – nn/aaa	Track group information:  nn Number of tracks per group (1, 2, 4, 5, 10). aaa Total number of track groups within the spool disk space.
11	TKGPS AVAIL – nnnn	Number of track groups currently available.

**DISPLAY Command (Continued)**

**Contents (Continued)**

The following chart provides an explanation of the system status display (5704-SC2):

Line	Characters Displayed	Meaning
1	SYSTEM STATUS DISPLAY	Identifies information in upper half of display.
2	SYSTEM REL nn	Release level of the system program.
	mm/dd/yy or dd/mm/yy	System date, in format specified during system generation.
	hh:mm:ss	Time, in hours, minutes, and seconds.
4	TASK PRIORITY- (xx,xx,xx = xx)	Task priority, listed in descending order; for example, SP,P3,P2,P1, where SP is the highest priority and P1 is the lowest. Where equal priority has been specified in the PTY command, equal signs (=) appear instead of commas.
	SHA-x	System history area status: halt (H)/nohalt (N)/CCP auto (C).
5	SHARE AREA-nnnK	Size of the file share area assigned to the system.
6	MAX PROG SIZE-nnK	Maximum size program that can be run in a partition.
7	nnnK AVAILABLE	Main storage not assigned to a partition or the file share area.
8	SPOOL STATUS DISPLAY	Identifies information in lower half of display. Lines 8-11 are blank if spooling is not supported by the system.
9 (10) (11)	RDR – ddddd PRT – ddddd PCH – ddddd	Reader, printer, and punch devices assigned to spooling during system generation.
	/status	Status of the spool queues:  ACT Queue contains jobs or steps to process. EMP Queue is empty. H Queue is held via the HOLD command.
9	UNIT-uuu	Unit containing the disk space used by spool.
	CYL-nnn	Number of cylinders assigned to the spool area during system generation or IPL.
10	TKGP SIZE – nn/aaaa	Track group information:  nn Number of tracks per group (1, 2, 4, 5, 10) aaaa Total number of track groups within the spool disk space.
11	TKGPS AVAIL – nnnn	Number of track groups currently available.

**DISPLAY Command (Continued)**

**Contents (Continued)**

The following chart provides an explanation of the partition status display (5704-SC2):

Line	Characters Displayed	Meaning
1	SYSTEM STATUS DISPLAY	Identifies information in upper half of display.
2	PARTn- <i>nnn</i> K	Partition number and size.
	h	Halt (H)/nohalt (N) status.
	p	Partition stopped via OCC (P).
	mm/dd/yy or dd/mm/yy	System date, in format specified during system generation.
	hh:mm:ss	Time, in hours, minutes, and seconds.
3	jobname stepname	Identity of job running in this partition.
3	F1 – <i>ddd</i>	Simulation areas assigned as F1, R1, F2, and R2 for this partition.
(4)	R1 – <i>ddd</i>	
(5)	F2 – <i>ddd</i>	
(6)	R2 – <i>ddd</i>	
4	RDR – <i>dddd</i>	Reader, printer, and punch devices assigned to this partition.
(5)	PRT – <i>dddd</i>	
(6)	PCH – <i>dddd</i>	
4	(SPOOL)	Displayed if the reader, printer, or punch device is assigned to spooling.
(5)	(SPOOL)	
(6)	(SPOOL)	
4	–SWITCH–	External indicator switch status.
(5)	<i>nnnnnnnn</i>	
8	SPOOL STATUS DISPLAY	Identifies information in lower half of display. Lines 8-11 are blank if spooling is not supported by the system.
9	RDR – <i>dddd</i>	Reader, printer, and punch devices assigned to spooling during system generation.
(10)	PRT – <i>dddd</i>	
(11)	PCH – <i>dddd</i>	
	/status	Status of the spool queues:  ACT Queue contains jobs or steps to process. EMP Queue is empty. H Queue is held via the HOLD command.
9	UNIT- <i>uuu</i>	Unit containing the disk space used by spool.
	CYL- <i>nnn</i>	Number of cylinders assigned to the spool area during system generation or IPL.

**DISPLAY Command (Continued)**

**Contents (Continued)**

Line	Characters Displayed	Meaning
10	TKGP SIZE – nn/aaaa	Track group information:  nn Number of tracks per group (1, 2, 4, 5, 10). aaaa Total number of track groups within the spool disk space.
11	TKGPS AVAIL – nnnn	Number of track groups currently available.

The format of the names display (5704-SC2) varies, depending on the user's disk drive configuration; the following chart provides an explanation of the sample names display shown previously in this chapter:

Line	Characters Displayed	Meaning
1	D1 – dddddd	Main data area on D1.
	D2 – dddddd	Main data area on D2.
2–3	1A – dddddd 1B – dddddd 1C – dddddd 1D – dddddd	Simulation areas on D1.
	2A – dddddd 2B – dddddd 2C – dddddd 2D – dddddd	Simulation areas on D2.
5	*31 – dddddd . . .	Main data areas on D3.
6–7	3A – dddddd . . . 3E – dddddd . . .	Simulation areas on D3.
9	*41 – dddddd . . .	Main data areas on D4.
10–11	4A – dddddd . . . 4E – dddddd . . .	Simulation areas on D4.



## DISPLAY Command (Continued)

### Contents (Continued)

*HISTORY (H)*: This operand displays the contents of the system history area. The display is on 11 lines of the screen, with lines 2 through 11 used for the actual display.

```
fnn      SYSTEM HISTORY DISPLAY  
  
display line 2  
  
display line 3  
      .  
      .  
      .  
  
display line 11  
  
ENTER DISPLAY REQUEST MSG NOT RSP mm
```

*Note:* The top line controls the direction of the display:

f =  $\left. \begin{array}{l} (F) \\ (B) \\ (C) \end{array} \right\}$  Forward  
Backward  
Cancel the display

nn applies to the F and B functions and specifies how many lines to roll each time the ENTER key is pressed. nn can range from 1 to 99.

**DISPLAY Command (Continued)**

**Contents (Continued)**

*task (5704-SC2 only):* One to seven of the following operands specify that the history of a single task or of a combination of tasks is to be displayed.

<b>Task Operand</b>	<b>Displays</b>
P1	History of partition 1
P2	History of partition 2
P3	History of partition 3
S	System messages
SP	Spool messages
OCC	Operator control commands
CCP	History of all CCP tasks
CCU	History of all CCP <i>user</i> tasks (group 1 below)
CCS	History of all CCP <i>system</i> tasks (group 2 below)
Cxx	History of one or more of these individual CCP tasks:

**Group 1**

C44	C99	CVV
C55	CEE	CWW
C66	CGG	CXX
C77	CHH	CYY
C88	CUU	CZZ

**Group 2**

CCC	(communications manager)
CDD	(display format facility—DFF)
CMM	(communications scheduler)
CPP	(command processor)
CTT	(termination task)

## DISPLAY Command (Continued)

### Contents (Continued)

The task operands are separated by commas, as in the following examples:

```
DISPLAY HISTORY,P1,P2,S,SP,OCC,CCU,CDD  
or  
D H,S,SP,CCP
```

When task operands are specified, the history of the tasks is displayed as follows:

```
fnn          SHA-task1,task2,task3,...  
  
display line 2  
  
display line 3  
.  
.  
.  
  
display line 11  
  
ENTER DISPLAY REQUEST  MSG NOT RSP  mm
```

*RDRQ (RQ)*: This operand is used to display information about the reader queue (see *Considerations*).

*PRTQ (WQ)*: This operand is used to display information about the print queue (see *Considerations*).

*PCHQ (PQ)*: This operand is used to display information about the punch queue (see *Considerations*).

## DISPLAY Command (Continued)

### Considerations

#### Queue Display Format

The format of the display is:

```
fnn qqg QUEUE      (h)
display line 2
display line 3
      }
display line 11

ENTER DISPLAY REQUEST MSG NOT RSP mm
```

You use line 1 to control scrolling of the display. To change the display, key the control codes into the appropriate positions, then press the ENTER key.

The meanings of the positions in line 1 are:

- f Enter F to roll the queue display, enter C to cancel the display. If neither F nor C is entered, F is assumed.
- nn Specifies the number of new lines to be added to the next display when the ENTER key is pressed.
- qqg Indicates which queue is being displayed.
- (h) Is H when the queue is currently being held. A queue is held by specifying it in the HOLD command. Lines 2 through 11 display the contents of the queue.

If, after displaying the contents of one queue, you want to display the contents of another, you can do so without entering another DISPLAY command. Enter the operand (RDRQ, RQ, PRTQ, WQ, PCHQ, or PQ) for the next queue you want to display in the first two or four positions of line 1 and press the ENTER key.

## DISPLAY Command (Continued)

### Considerations (Continued)

*Reader Queue Display:* The following is an example of a reader queue display containing the jobname, stepname, position on the queue, priority number, the amount of storage required, and the partition the job will be executed in. The storage required is displayed only if it was specified on the JOB OCL statement or through the CHANGE core command. For 5704-SC2, jobs placed on the reader queue by \$QCOPY under CCP will have the terminal name displayed in the stepname position.

```
F10      RDR QUEUE (H)      POS  PR  CORE  PT
---PRIORITY LIMIT 3---
FIRST                                1  A5   10K   1
JOB-E                                2   5                   1
JOB-F                                3 HQ4    3K   2
JOB-J                                4  H4                   2
JOB-L  TERM01                       5  H3   24K   3
JOB-I  TERM02                       6 KA2                   2
JOB-M                                7  K1                   1
ACCOUNTS                             8   1  136K  3N

                                END OF QUEUE
ENTER DISPLAY REQUEST          MSG NOT RSP 01
```

An (H) on the first line of the display indicates that the entire reader queue is held via the HOLD command.

For 5704-SC2, if the priority limit for jobs placed on the reader queue by \$QCOPY under CCP is less than five, the limit is displayed on the second line of the display.

One or two of the following characters can precede the priority number in the display:

- A — Indicates that the job is currently executing in the partition shown in the *PT* column (5704-SC2 only)
- H — Indicates that the job is being held via the HOLD command
- K — Indicates that the job is in a keep state via the KEEP command (5704-SC2 only)
- Q — Indicates that the job is being copied by \$QCOPY (5704-SC2 only)

For 5704-SC2, an N following the partition number indicates that QCOPY-NO was specified on the JOB OCL statement.

## DISPLAY Command (Continued)

### Considerations (Continued)

*Print Queue Display:* The following is an example of a display of the print queue containing the jobname, stepname, position on the queue, job priority, forms type, the number of copies to be printed, and the number of pages within each copy.

An (H) on the first line of the display indicates that the entire print queue is held via the HOLD command.

One or two of the following characters can precede the priority number in the display:

- A — Indicates that the job step is currently being printed
- H — Indicates that the job or job step is being held via the HOLD command
- K — Indicates that the job or job step is in a keep state via the KEEP command (5704-SC2 only)
- Q — Indicates that the job or job step is being copied by \$QCOPY (5704-SC2 only)
- R — Indicates that the job step was partially canceled with a REUSE command and is no longer being printed (5704-SC2 only )

For 5704-SC2, an N after the number of copies indicates that QCOPY-NO was specified on a PRINTER OCL statement.

An asterisk (\*) after the number of copies indicates that the job step is currently executing and that a PRINTER statement with DEFER-NO was specified for the job step. (A job step that is executing without DEFER-NO specified is not displayed.)

**DISPLAY Command (Continued)**

**Considerations (Continued)**

The active forms type will be displayed in the message:

nnn IS ACTIVE FORMS TYPE

If the print writer was started using a forms type:

```
F10  PRT QUEUE(H) POS  PR  FRM  CPY  PAGES
      ---BCD IS ACTIVE FORMS TYPE---
JOB-E  PRINT          1  H5  SPC  99     3
      PUNCH          2  KA5 BCD   1    407
ACCOUNTS DUE         3  K4  BCD   1    22
      PAYABLE        4  R4  BCD   2   115
PAYROLL CHECKS       5   1  CKS  1N   432
      REGISTER       6  KQ1 BCD   1   432
      YTDMASR       7   1  BCD  1*    71
      END OF QUEUE

ENTER DISPLAY REQUEST          MSG NOT RSP 01
```

## DISPLAY Command (Continued)

### Considerations (Continued)

*Punch Queue Display:* The following is an example of a punch queue display containing the jobname, stepname, position on the queue, priority, card type, the number of copies to be punched, and the number of cards within each copy.

An (H) on the first line of the display indicates that the entire punch queue is held via the HOLD command.

One or two of the following characters can precede the priority number in the display:

- A — Indicates that the job step is currently being punched
- H — Indicates that the job or job step is being held via the HOLD command
- K — Indicates that the job or job step is in a keep state via the KEEP command (5704-SC2 only)
- Q — Indicates that the job or job step is being copied by \$QCOPY (5704-SC2 only)
- R — Indicates that the job step was partially canceled with a REUSE command and is no longer being punched (5704-SC2 only)

For 5704-SC2, an N after the number of copies indicates that QCOPY-NO was specified on a PUNCH OCL statement.

An asterisk (\*) after the number of copies indicates that the job step is currently executing and that a PUNCH statement with DEFER-NO was specified for the job step. (A job step that is executing without DEFER-NO specified is not displayed.)

F03	PCH	QUEUE (H)	POS	PR	CRD	CPY	CARDS
JOB-D		STEP-2	4	H5	BCD	3	54
JOB-E		PUNCH	5	H5	BCD	1	53
JOB-F		PUNCH	6	KA4	BCD	1	50
PAYROLL		CHECKS	7	K3	CKS	7	198
ACCOUNTS		YTDMASTR	8	1	BCD	1	27
		PAYABLE	9	1	BCD	1N	33
TIMECARD		PLANT	10	Q1	PLT	1	71
		LAB	11	R1	LBT	1	3
		SUMMARY	12	1	BCD	2*	82
END OF QUEUE							
ENTER DISPLAY REQUEST MSG NOT RSP 01							



## DUMP Command

### Function

Produces a main storage dump of a partition or of the total system.

### Format

#### Operation

#### Operand

DUMP  
(K)

$$\left( \begin{array}{l} P1 \left[ \begin{array}{l} 2 \\ 3 \end{array} \right] \\ P2 \left[ \begin{array}{l} 2 \\ 3 \end{array} \right] \\ P3 \left[ \begin{array}{l} 2 \\ 3 \end{array} \right] \\ \text{SYSTEM [,DISK]} \\ (S) \end{array} \right)$$

### Contents

*P1, P2, or P3:* This operand specifies the storage allocated to that partition and any areas of the supervisor associated with the partition are to be dumped.

Job processing can be resumed after the dump is complete.

*2 or 3:* This operand specifies the option for a cancel associated with the dump. When the 2 option is selected, files used by the job step executing when the dump is requested reflect all activity up to the point of the dump. If the 3 option is selected, the disposition of the files depends on the function being performed at the time the dump is requested:

- New files being created are not retained.
- Old files being deleted are retained.
- If SHARE-YES was specified, old files being added to will reflect the additions that have been written to the disk up to the point at which the DUMP command occurred.
- Old files being added to do not reflect the additions if SHARE-NO was specified on the FILE statement.
- Old files being updated reflect the updates that have been written to the disk at the point at which the DUMP command is entered.

The end-of-step message issued after either dump has taken place indicates that the job step was canceled. If the program executing when the DUMP command is entered is a step of a job or a procedure in a nested procedure, all remaining job steps in the job or all remaining procedures in the nested procedure are canceled. Spooled output data files that belong to the canceled job step are saved and may be printed or punched. If the printed output for the partition being dumped is being spooled, the dump output is also spooled. This dump terminates in normal end of step, and job processing can be resumed in the partition by responding to the end-of-step message.

*Note:* If neither the 2 nor 3 option is requested when you enter the DUMP command, the 2 option is assumed.

## DUMP Command (Continued)

### Contents (Continued)

*SYSTEM* specifies a total storage dump of the system. The dump includes all communication regions except the transient area. A PL halt appears on the message display unit when the dump is complete. You must press START on the system control panel to continue.

*DISK (5704-SC2 only)*: This operand specifies that the following are to be written to a user-provided disk file called \$SYSDUMP (see Appendix F):

- Entire contents of main storage
- Scheduler work areas for P1, P2, and P3
- Saved transient area, if available<sup>1</sup>
- Part of the system history area
- System and CCP configuration records (5704-SC2 only)
- PTF log sectors from system and CCP packs (5704-SC2 only)
- 3340, BSCC, and display adapter microcode levels (5704-SC2 only)
- Outboard and statistical error recording data (5704-SC2 only)
- Disk and tape error recording data (5704-SC2 only)

The contents of \$SYSDUMP can be printed at a later time if you run the \$CPRNT program (see Appendix G).

### Considerations

After the DUMP command has been entered, CAN NOT ACCEPT is displayed if one of the following conditions exists:

- The copy reader to library or modify functions of \$MAINT are being used.
- Job initiation or termination is being processed in the specified partition.
- The 2 option is specified but the partition has a message pending that allows only the 3 option.
- Partition 2 or partition 3 is specified but it is set to zero.
- A START SPOOL command issued at IPL time has not been completed.

<sup>1</sup>The transient area is included only if a process check occurs in a nonsystem program executing in the transient area, and if the DUMP command is entered before end of job for that partition.

## HALT Command

### Function

Causes the partition to halt with an EJ or ES message after the current job step is complete; or causes the system to halt or \$HACCP to be automatically invoked before unprinted system history area entries are overlaid.

### Format

#### Operation

#### Operand

HALT  
(HT)

P1
P2
P3
SHA [,CCP] [,tracks]

### Contents

*P1, P2, or P3:* This operand specifies the partition in which you want to suspend job processing when end of job or end of job step occurs. If no operand is specified, P1 is assumed.

*SHA:* This operand indicates that you want the system to halt with a message when entries are about to overlay system history area entries that have not been printed.

*CCP (5704-SC2 only):* This operand specifies that, when unprinted system history area entries are about to be overlaid, \$HACCP is to be automatically invoked under CCP to copy the system history area to a disk file.

*tracks (5704-SC2 only):* This operand defines the SHA warning point. The value entered specifies the number of tracks between the warning point and the first unprinted entry. The tracks operand can be any number from 0 through 10 that does not exceed half the SHA size. If you specify 0 tracks, the warning point is set at approximately 50 records. (A tracks operand of 0 is not valid in combination with the CCP operand.)

### Considerations

With this command, you can override the nohalt mode established by a NOHALT OCL statement or the nohalt mode established by the system. This override is in effect in the specified partition until a NOHALT command is entered or until you perform the IPL process again.

To resume processing in the partition, you respond to the end of job step message.

The message THE SHA IS FULL is not displayed unless the HALT SHA command is entered. After this command is entered, the message is displayed whenever entries are about to overlay unprinted system history area entries. This command remains in effect until the NOHALT SHA command is entered. After the message has been issued, it is not displayed again until the \$HIST or \$HACCP program has been executed to print or copy the contents of the system history area.

If you enter HALT SHA,CCP, no message appears unless \$HACCP cannot be loaded under CCP; \$HACCP is automatically invoked at the warning point specified by the tracks operand.

*Note:* The \$HACCP (System History Area Copy) program is used with CCP only. The program is described in the *IBM System/3 Model 15 Communications Control Program System Operator's Guide*, GC21-7619.

**HIPTY Command (5704-SC2 only)**

<b>Function</b>	Limits the priority of jobs placed on the active spool file reader queue by \$QCOPY (spool file copy program) under CCP. This command is valid only for 5704-SC2 systems that support spooled reading and only when spooling is active.	
<b>Format</b>	<b>Operation</b>	<b>Operand</b>
	HIPTY (HP)	high-priority
<b>Contents</b>	<i>high-priority:</i> This operand can be any value from 0 through 5; it specifies the high-priority limit of jobs placed on the active spool file reader queue by \$QCOPY under CCP. For example, if you specify 3 as the high-priority operand, the highest priority allowed for jobs placed in the reader queue by \$QCOPY under CCP is 3. If you specify 0, the priority is limited to 1 and held.	
<b>Considerations</b>	A job with a JOB statement error will be placed on the queue with priority 5, regardless of the HIPTY limit.  A job being placed on the queue at the time the HIPTY command is entered will not be affected by the limit specified.  The limit specified remains in effect until another HIPTY command is entered or until an IPL is performed. After an IPL, the limit in effect is 5 unless otherwise specified by \$CNFIG.	

## HOLD Command

### Function

Prevents one or more jobs or job steps from being scheduled for input or output or prevents the entire contents of a queue from being scheduled for input or output. This command is valid only if spooling is active. The job or job step is held on the queue until you release it by a RELEASE command or cancel it with a CANCEL command. If the entire queue is held, it remains held until you release it with a RELEASE command.

### Format

Operation	Operand
HOLD (H)	$\left. \begin{array}{l} \text{RDRQ } [ \text{,jobname} ] \\ \text{(RQ)} [ \text{,characters}^{**} ] \\ \\ \text{PRTQ } [ \text{,jobname} \quad [ \text{,stepname} ] \\ \text{(WQ)} [ \text{,characters}^{**} \quad [ \text{,characters}^{**} ] ] \\ \\ \text{PCHQ } [ \text{,jobname} \quad [ \text{,stepname} ] \\ \text{(PQ)} [ \text{,characters}^{**} \quad [ \text{,characters}^{**} ] ] \end{array} \right\}$

### Contents

*RDRQ (RQ)*: This operand prevents the execution of any job from the reader queue; however, jobs can continue to be placed in the reader queue. Using the optional jobname parameter, only a particular job is held.

*PRTQ (WQ)*: This operand prevents any output from being removed from the print queue; however, output from executing jobs or steps can continue to be placed in the print queue. Using the optional jobname parameter, all steps of the specified job are held. Using the jobname and stepname parameters, only a particular step is held.

*PCHQ (PQ)*: This operand prevents any output from being removed from the punch queue; however, output for executing jobs or steps can continue to be placed in the punch queue. Using the optional jobname parameter, all steps of the specified job are held. Using the jobname and stepname parameters, only a particular step is held.

*jobname*: This operand specifies the job to be held.

*stepname*: This operand specifies the job step to be held.

*characters\*\* (5704-SC2 only)*: This operand specifies the jobs and/or job steps to be held. Multiple jobs/steps can be referenced by specifying one to seven characters followed by two asterisks (\*\*). All jobs/steps on the queue whose names begin with the specified characters will be held.

### Considerations

The job or job step is held on the queue until released by a RELEASE command or canceled by a CANCEL command. If the entire queue is held, it remains held until released by a RELEASE command.

Holding a job on the reader queue has the same effect as specifying PRIORITY-0 on the JOB statement. The RELEASE command is required to remove a job from the hold state.

**This page is intentionally left blank.**

## HOLD Command (Continued)

### Considerations (Continued)

When a job that is still executing is held by jobname on the print or punch queue, only those steps of the job that are on the queue at the time of the HOLD commands are held. Subsequent steps of the job placed on the queue are not held.

When used to hold jobs or steps, the HOLD command takes effect immediately. When used to hold an entire queue, the command does not take effect immediately. Consider the following examples:

1. HOLD PRTQ,JOBA  
or  
H WQ,JOBA

If this command is entered while JOBA is being printed, the writer immediately terminates printing JOBA and continues with the next job on the queue. When JOBA is released, it is printed from the beginning, or from the beginning of the interrupted copy if multiple copies were requested. (This action also occurs for holding steps, as well as jobs, on the print and punch queues.)

2. HOLD PRTQ  
or  
H WQ

When the entire queue is held, the step currently printing is completed before the queue is held. If multiple copies are requested, the queue is held when the current copy is complete. When the queue is released, printing begins with the next copy.

## **IDELETE Command**

### **Function**

Causes the system to automatically delete information (I) type messages that have not been responded to. Normally a response is required to remove these messages.

### **Format**

<b>Operation</b>	<b>Operand</b>
IDELETE (I)	None

### **Considerations**

Information (I-type) messages are usually kept in the response queue and the system history area until they are responded to. After the IDELETE command is entered, the oldest information message is automatically deleted when the tenth message occurs on the response queue.



## KEEP Command (5704-SC2 only)

**Function** Causes one or more jobs or job steps to be placed back on the queue in a hold state after being printed, punched, or executed. This command is valid only if spooling is active.

Format	Operation	Operand
	KEEP (KP)	$\left\{ \begin{array}{l} \text{RDRQ, } \left\{ \begin{array}{l} \text{jobname} \\ \text{characters}^{**} \end{array} \right\} \\ \text{(RQ)} \\ \\ \text{PRTQ, } \left\{ \begin{array}{l} \text{jobname} \\ \text{characters}^{**} \end{array} \right\} \left[ \begin{array}{l} \text{,stepname} \\ \text{,characters}^{**} \end{array} \right] \\ \text{(WQ)} \\ \\ \text{PCHQ, } \left\{ \begin{array}{l} \text{jobname} \\ \text{characters}^{**} \end{array} \right\} \left[ \begin{array}{l} \text{,stepname} \\ \text{,characters}^{**} \end{array} \right] \\ \text{(PQ)} \end{array} \right\}$

**Contents** *RDRQ, PRTQ, or PCHQ:* This operand specifies the queue that contains the job or job step to be kept.

*jobname:* This operand specifies the job to be kept.

*stepname:* This operand specifies the job step to be kept.

*characters\*\* (5704-SC2 only):* This operand specifies the jobs and/or job steps to be kept. Multiple jobs/steps can be referenced by specifying one to seven characters followed by two asterisks (\*\*). All jobs/steps on the queue whose names begin with the specified characters will be kept.

**Considerations** The KEEP command cannot be used unless the job or job step is on the queue and is not executing. The job or job step is kept in the queue until it prints, punches, or executes; or until it is released by a RELEASE command or canceled by a CANCEL command.

## NOHALT Command

### Function

Changes the processing mode from halt to nohalt or prevents an informational message when unprinted entries in the system history area are about to be overlaid by additional entries.

### Format

#### Operation

#### Operand

NOHALT  
(NHT)

P1
P2
P3
SHA

### Contents

*P1, P2, or P3:* This operand specifies the partition that is to be changed to nohalt mode. If no operand is specified, P1 is assumed.

*SHA:* This operand indicates that you do not want any action taken when additional entries to the system history area are about to overlay unprinted entries.

### Considerations

The NOHALT command overrides the halt mode established by the HALT command. When NOHALT  $\left\{ \begin{matrix} P1 \\ P2 \\ P3 \end{matrix} \right\}$  is specified, the partition does not stop when an end of job or end-of-job step occurs. The partition remains in nohalt mode until altered by the HALT command or the HALT OCL statement.

The command NOHALT SHA has no effect unless the command HALT SHA was entered previously.

## KEEP Command (5704-SC2 only)

**Function** Causes a job or job step to be placed back on the queue in a hold state after it has been printed, punched, or executed. This command is valid only if spooling is active.

Format	Operation	Operand
	KEEP (KP)	$\left\{ \begin{array}{l} \text{RDRQ,jobname} \\ \text{(RQ)} \\ \\ \text{PRTQ,jobname[,stepname]} \\ \text{(WQ)} \\ \\ \text{PCHQ,jobname[,stepname]} \\ \text{(PQ)} \end{array} \right\}$

**Contents** *RDRQ, PRTQ, or PCHQ:* This operand specifies the queue that contains the job or job step to be kept.

*jobname:* This operand specifies the job to be kept.

*stepname:* This operand specifies the job step to be kept.

**Considerations** The KEEP command cannot be used unless the job or job step is on the queue. The job or job step is kept in the queue until it prints, punches, or executes; or until it is released by a RELEASE command or canceled by a CANCEL command.

## NOHALT Command

### Function

Changes the processing mode from halt to nohalt or prevents an informational message when unprinted entries in the system history area are about to be overlaid by additional entries.

### Format

Operation	Operand
NOHALT (NHT)	$\left[ \begin{array}{c} P1 \\ P2 \\ P3 \\ SHA \end{array} \right]$

### Contents

*P1, P2, or P3:* This operand specifies the partition that is to be changed to nohalt mode. If no operand is specified, P1 is assumed.

*SHA:* This operand indicates that you do not want the informational message THE SHA IS FULL displayed when additional entries to the system history area are about to overlay unprinted entries.

### Considerations

The NOHALT command overrides the halt mode established by the HALT command. When NOHALT  $\left\{ \begin{array}{c} P1 \\ P2 \\ P3 \end{array} \right\}$  is specified, the partition does not stop when an end of job or end-of-job step occurs. The partition remains in nohalt mode until altered by the HALT command or the HALT OCL statement.

The command NOHALT SHA has no effect unless the command HALT SHA was entered previously.

## **NODELETE Command**

**Function** Causes the system to stop deleting I-type messages that have not been responded to.

<b>Format</b>	<b>Operation</b>	<b>Operand</b>
	NODELETE (NI)	None

**Considerations** If the system does not automatically delete I-type messages that have not been responded to, you must respond to them when the response queue is full. Otherwise, the system cannot continue processing.

## PTY Command

### Function

Changes the priority of the following tasks in the system control program:

Spooling (reader, print writer, punch writer)  
Partition 1  
Partition 2  
Partition 3

The priority of these tasks determines the order in which they receive the services of the system control program. The spooling task refers to the spooled reader and/or writer. The PTY command can be entered at any time.

At IPL, the priority of these tasks is SPOOL, P3, P2, P1, with SPOOL having the highest priority. If SPOOL is not used, the priority is P3, P2, P1, with P3 having priority over P2 and P1. If SPOOL is not used and P3 is not supported (5704-SC1), the priority is P2, P1, with P2 having priority over P1.

### Format

#### Operation

#### Operand

PTY  
(Y)

$\left. \begin{array}{l} \text{SPOOL} \\ \text{(SP)} \\ \text{P1} \\ \text{P2} \\ \text{P3} \end{array} \right\} \left\{ \begin{array}{l} \text{=} \\ \text{-} \end{array} \right\} \dots$

### Contents

*SPOOL*: This operand specifies the spooling task for a priority change.

*P1, P2, or P3*: These operands specify the partition to which the priority change applies.

### Considerations

The order of the operand indicates the requested priority: the leftmost operand has the highest priority; the rightmost operand has the lowest. Two or more tasks can be given equal priority by specifying an equal sign (=) or a dash (–) instead of a comma (,) between the operands (5704-SC2 only).

The following rules apply to the operands on the PTY command:

1. Each operand can be specified only once.
2. SPOOL is an invalid operand if spooling is not supported or is canceled.
3. All operands must be specified; there are no defaults.

The following examples illustrate the first three rules:

#### 5704-SC1

SP,P2,P1  
P1,P2

#### 5704-SC2

P1,P2,P3,SP  
P1,P2,P3  
P1=P2=P3  
P1–P2–P3  
SP,P2,P1  
P1,P2

## PTY Command (Continued)

### Considerations (Continued)

4. Only one group of operands may be equated. For example:

`SP=P3,P2=P1`

is not valid, but:

`SP=P3=P2=P1` and `SP,P3=P2=P1`

are valid.

5. The task that contains the communications control program (CCP) cannot be given equal priority with another task. For example:

`P3=SP,P2,P1`

is not valid if CCP is executing in P3, but:

`P3,SP=P1=P2`

is valid.

To improve the throughput of nonspooling tasks, the priority of the spooling tasks can be lowered if:

- The spooled output (print or punch) is of low volume.
- Turnaround time is not important.

Changing the priority can increase the performance of one task at the expense of another task.

For example, to cause the spooling task to have a lower priority in the system control program than P1 or P2, but higher than P3, the following command can be entered:

`PTY P2,P1,SPOOL,P3`

or

`Y P2,P1,SP,P3`

## READER Command

**Function** Changes the system input device for a partition.

**Format**

Operation	Operand
READER (RDR)	$\left[ \begin{array}{c} P1 \\ P2 \\ P3 \end{array} \right], \text{ device}$

**Contents** *P1, P2, or P3:* This operand specifies the partition for which you want to change the system input device. If no partition is specified, P1 is assumed.

*Device:* Specifies which device to assign:

MFCU1	Primary hopper of the MFCU
MFCU2	Secondary hopper of the MFCU
MFCM1	Primary hopper of the MFCM
MFCM2	Secondary hopper of the MFCM
1442	1442 Card Read Punch
2501	2501 Card Reader
CONSOLE	CRT/Keyboard
3741	Data Station or Programmable Work Station

**Considerations** When this command is entered, the specified partition must be at end of job or end-of-job step, and must not yet have a system input device assigned to it. The assigned device remains as the system input device until changed by another READER command or READER OCL statement, or until an IPL is performed. You can change the system input device in a spooled job stream; however, jobs are scheduled for execution from the reader queue only when the system input device is the spooled reader.



## RELEASE Command

### Function

Releases a queue or one or more jobs or job steps that were placed in a hold state by the HOLD command or assigned a PRIORITY-0 on a JOB, PRINTER, or PUNCH statement. This command is valid only if spooling is active.

### Format

Operation	Operand
RELEASE (R)	$\left. \begin{array}{l} \text{RDRQ } [ \text{,jobname} \\ \text{(RQ)} \quad [ \text{,characters}^{**} ] \\ \\ \text{PRTQ } [ \text{,jobname} \quad [ \text{,stepname} \\ \text{(WQ)} \quad [ \text{,characters}^{**} \quad [ \text{,characters}^{**} ] ] \\ \\ \text{PCHQ } [ \text{,jobname} \quad [ \text{,stepname} \\ \text{(PQ)} \quad [ \text{,characters}^{**} \quad [ \text{,characters}^{**} ] ] \end{array} \right\}$

### Contents

*RDRQ (RQ)*: This operand releases the reader queue. Any jobs on the queue that are in a hold state continue to be held. Using the optional jobname parameter, only a particular job is released. The RDRQ operand is valid only on systems that support input spooling.

*PRTQ (WQ)*: This operand releases the print queue. Any jobs or steps on the queue that are in a hold state continue to be held. Using the optional jobname parameter, all steps of the specified job are released. Using the jobname and stepname parameters, only a particular step is released.

*PCHQ (PQ)*: This operand releases the punch queue. Any jobs or steps on the queue that are in a hold state continue to be held. Using the optional jobname parameter, all steps of the specified job are released. Using the jobname and stepname parameters, only a particular step is released. The PCHQ operand is valid only on systems that support punch spooling.

*jobname*: This operand specifies the job to be released.

*stepname*: This operand specifies the job step to be released.

*characters\*\* (5704-SC2 only)*: This operand specifies the jobs and/or job steps to be released. Multiple jobs/steps can be referenced by specifying one to seven characters followed by two asterisks (\*\*). All jobs/steps on the queue whose names begin with the specified characters will be released.

## RELEASE Command (Continued)

### Considerations

A released job or job step that was previously held by a HOLD command retains the priority assigned to it.

A job that was held by jobname is not released by using only a RDRQ, PRTQ, or PCHQ operand; it must be released by jobname.

A step that was held by jobname and stepname is not released by using only a RDRQ, PRTQ, or PCHQ operand; it must be released by jobname and stepname.

The RELEASE command does not always void all functions of the HOLD command. If a job step that was being printed or punched is held and then released while the writer is waiting or stopped, the writer acts like the job step is still held when it starts. This causes the first available job step on the queue to be printed or punched.

Consider the following example:

```
RELEASE RDRQ  
or  
R RQ
```

This command releases the reader queue previously held by a HOLD RDRQ command.

## RESTART Command

### Function

Restarts a job step's printed or punched output if entered while the print or punch writer is active. If entered when the writer is not active, the RESTART command causes the writer to start with the job step that was stopped, if one was stopped, or from the beginning of the queue if no job steps were previously stopped.

### Format

Operation	Operand
RESTART (T)	$\left[ \begin{array}{l} \frac{\text{PRT}}{\text{(W)}} \left[ \begin{array}{l} \text{,PAGE} \\ \text{(PG)} \\ \text{,number} \end{array} \right] \\ \\ \text{PCH} \\ \text{(P)} \end{array} \right]$

### Contents

*PRT (W)*: This operand causes the output of the step currently being printed to be restarted. If an operand is not specified for the RESTART command, PRT is assumed.

*PAGE (PG)*: This operand causes the print writer to restart at the beginning of the current page if entered when the print writer is active. If entered when the print writer is not active, this operand causes the print writer to start printing from the beginning of the first page not previously finished. This operand is not accepted after page 65,535 has been printed. If PAGE is specified when starting the print writer after IPL, PAGE is ignored and page 1 is started.

*number*: This operand specifies the number (1 to 65,535) of the page to be started. If the number specified is higher than any page in the job step, spool issues an error message or waits for the specified page if the job step is still executing.

*PCH (P)*: This operand causes output from the step currently being punched to be restarted from the beginning.

This page is intentionally left blank.

## RESTART Command (Continued)

### Considerations

When the RESTART PRT or RESTART PCH command is entered, the printing or punching of the current job step is immediately terminated. Depending on the command entered, the message PRT RESTART PENDING or PCH RESTART PENDING is displayed. The message allows the operator to correct any situation that may have caused the RESTART to be entered. Response to the message initiates the restart.

A STOP command is not required before a RESTART command is issued; however, a RESTART command can be entered following a STOP command.

When the print writer is restarted to a page, the restart may not occur immediately. The length of time required to find the page in the spool file will vary depending on the page number required, the priority of the spool print writer in relation to the program partitions, and the track group size used in the spool file.

If the print or punch writer is producing output for a job step that is currently executing and a RESTART writer command is entered while the writer is waiting for more data from the job step, the writer is not restarted until the job step produces the required data for the writer or until the job step completes.

You should respond to any I/O error messages before entering the RESTART PRT or RESTART PCH command. The RESTART command is not executed until you have responded to these I/O error messages.

Consider the following example:

```
RESTART  
or  
T
```

This command causes the print writer to immediately stop printing the current job step. When the operator responds to the message PRT RESTART PENDING, the print writer prints the job step's output starting with the first page.

## REUSE Command (5704-SC2 only)

**Function** Frees space in the spool file from the currently printing or punching job step before that job step has completed printing or punching. This command is valid only if spooling is active.

Format	Operation	Operand
REUSE (RU)		$\left. \begin{array}{l} \text{PRTQ} \\ \text{(WQ)} \end{array} \right\} \text{,jobname[,stepname]}$ $\left. \begin{array}{l} \text{PCHQ} \\ \text{(PQ)} \end{array} \right\} \text{,jobname[,stepname]}$

**Contents** *PRTQ* or *PCHQ*: This operand specifies the queue that contains the currently printing or punching job step to which the reuse applies.

*jobname*: This operand specifies the job to which the reuse applies.

*stepname*: This operand specifies the job step to which the reuse applies.

## Considerations

The REUSE command is most useful when the SPOOL FILE FULL message is displayed. The REUSE command frees space from the current step that is printing or punching. This freed space can be used for any spooled input or output from any partition.

If spool has been stopped after space has been freed from a print step, then that print step can be restarted only if you enter a RESTART command with a number of a page that is still in the queue (less than 65,535).

If spool has been stopped after space has been freed from a punch step, then that punch step cannot be restarted; so do not stop spool if REUSE has been entered for a punch step and that step is still punching.

When a REUSE command is entered, the number of copies for the job step is set to one and cannot be changed at a later time. A HOLD command is not allowed for a job step if the step is still being printed or punched.

After a REUSE command has been entered for a job step, the spool file that contains that step can be used only by SCP 5704-SC2 (release 2 or later).

Consider the following example:

```
REUSE PRTQ,JOBA  
or  
RU WQ,JOBA
```

If this command is entered while JOBA is being printed, it will be accepted, and disk space in the spool file will be made available for use by other spooled input or output.

## ROLLOUT Command

**Function** Interrupts a rollout-evoking program to allow another program to be loaded and executed. This command applies only to programs executing in partition 1. For more information on using ROLLOUT, see *Interrupting an Object Program* in *Chapter 19. Object Program Execution*.

<b>Format</b>	<b>Operation</b>	<b>Operand</b>
	ROLLOUT (RO)	None

**Contents** None

**Considerations** This command is valid only on systems that support the rollout/rollin type of inquiry feature (program 5704-SC1 only). If a ROLLOUT command is entered when a program is currently rolled out, the second ROLLOUT command is not accepted.

## SET Command

**Function** Overrides the partition size or the file share area size specified during system generation.

**Format**

Operation	Operand
SET	$\left[ \begin{array}{c} P1 \\ P2 \\ P3 \\ SH \end{array} \right], \text{size}$

**Contents** *P1, P2, P3, or SH:* Specifies the partition or the file share area in which you want to change the storage size. If P1, P2, P3, or SH is not specified, P1 is assumed.

*SH:* This operand must be at least 2K, and sizes greater than 2K must be specified in multiples of 2K (5704-SC2 only).

*Size:* A 3-digit number specifying the new storage size in units of 1K. If the storage size specified by this operand is not a multiple of 2K, it is rounded up to the next higher 2K increment.

## Considerations

CAN NOT ACCEPT will be displayed if the given partitions are not at end of job or end of job step for the specified partition or file share area as follows:

- For P1, partition 1 must be at end of job or end-of-job step.
- For P2, partition 2 must be at end of job or end-of-job step.
- For P3, partition 2 and partition 3 must be at end of job or end-of-job step.
- For SH, partition 1, partition 2, and partition 3 must be at end of job or end-of-job step.

When this command is entered, CAN NOT ACCEPT is displayed if system generation is being performed or if rollin is pending. If the specified partition is at end-of-job step but not end of job, the partition size may not be decreased to less than:

- The size specified in the CORE parameter of the JOB OCL statement.
- The size of the partition at the start of the job, if the CORE parameter is not specified in the JOB OCL statement.

The minimum partition size for partition 1 is 8K. Partition 2 and partition 3 can be set to zero if you want to run the system with only one partition.

When partition 2 and partition 3 are set to zero, the CANCEL and DUMP commands are not accepted for these partitions. Partition 2 or partition 3 can be reactivated with another SET command specifying 8K or more. The maximum partition size that can be specified is the system storage size, minus the size of the supervisor. If you must decrease the size of one partition in order to increase the other, you must do the decrease operation first.



## SIMULATE Command

**Function** Allows drive D2 to be treated as a removable pack on a 3340 Direct Access Storage Facility and controls support for R2 and F2 (5704-SC1 only).

<b>Format</b>	<b>Operation</b>	<b>Operand</b>
	SIMULATE (SM)	{ ON } { OFF }

**Contents** *ON*: This operand indicates that R2 and F2 are supported and simulated on drive 2 of a 3340. Disallows functions calling for the removal of D2.

*OFF*: This operand indicates that R2 and F2 are not supported. (Allows D2 to be treated as a removable data module.)

**Considerations** The SIMULATE command is valid only if:

- Program number 5704-SC1 is used.
- The 3340 is supported.
- Both partitions are at end of job.
- Neither partition is using nested procedures.
- A rollin is not pending.

## START Command

### Functions

- Activates spooling immediately after IPL.
- Starts the input spooling routine (reader), print writer, or punch writer.
- Starts spooling in a partition that has had spooling stopped by the STOP command.

*Note:* The preceding functions are valid only for systems that support spooling.

- Starts program execution in a partition (5704-SC2 only).

### Format

Operation	Operand														
START (S)	<table><tr><td>SPOOL (SP)</td><td>[ ,P1 ,P2 ,P3 [,NEW] [,unit] [,size] [,track group size]</td></tr><tr><td>RDR (R)</td><td>[,ROLL]</td></tr><tr><td>PRT (W)</td><td>[,forms type]</td></tr><tr><td>PCH (P)</td><td></td></tr><tr><td>P1</td><td></td></tr><tr><td>P2</td><td></td></tr><tr><td>P3</td><td></td></tr></table>	SPOOL (SP)	[ ,P1 ,P2 ,P3 [,NEW] [,unit] [,size] [,track group size]	RDR (R)	[,ROLL]	PRT (W)	[,forms type]	PCH (P)		P1		P2		P3	
SPOOL (SP)	[ ,P1 ,P2 ,P3 [,NEW] [,unit] [,size] [,track group size]														
RDR (R)	[,ROLL]														
PRT (W)	[,forms type]														
PCH (P)															
P1															
P2															
P3															

## START Command (Continued)

### Contents

*SPOOL (SP)*: This operand activates spooling at IPL or starts spooling after it was stopped in a partition. If used with the *NEW*, *unit*, *size*, and/or *track group size* parameters, the *SPOOL* operand can be entered only at IPL prior to initiation of the first job. If any of these values is omitted, the value specified during system generation is used. Once spooling is activated by the *START* command, spooling remains active until you enter a *STOP* command.

*P1, P2, or P3*: This optional parameter of the *SPOOL* operand is used to start spooling in a partition in which spooling was stopped by a *STOP* command. The *START* command specifying a partition can be entered only after the spooling function has been activated. If the *START* command with the partition parameter is entered at the end of a job when the system input device has been released, spooling for the partition begins immediately. If it is entered during the execution of a job, it takes effect at the next end of job (not end of step) that releases the system input device.

*NEW*: This optional parameter of the *SPOOL* operand causes the spooling area on disk to be reformatted. Previous input or output in this area is lost. When *NEW* is specified and data is found in the spool file, the message *THE SPOOL FILE CONTAINS DATA* warns that data will be destroyed if a *continue* option is taken. Options to the message allow the operator to *continue* or *cancel* the *START SPOOL,NEW* request. If *NEW* is not specified, existing data in the spooling area is not lost. If no data exists, the area is reformatted.

*Unit*: This optional parameter of the *SPOOL* operand changes the disk unit on which spooled records are written. The *unit* parameter can be *D1, D2, D3, D31, D32, D33, D34, D4, D41, D42, D43, or D44*. The specified disk unit overrides the unit specified during system generation and remains in effect until the next IPL. If the same spool file is to be used after the next IPL, the *unit* parameter must again be specified.

## START Command (Continued)

### Contents (Continued)

*Size:* This optional parameter specifies the size of the spooling area, in number of cylinders. The maximum size that may be specified is 199 for a 5445, 166 for a 3340 main data area, and 186 for a 3344 main data area. This parameter overrides the value specified during system generation only when NEW is specified, and it remains in effect until that spooling disk area is reformatted or a new area is built on the disk pack. Whenever size is specified, NEW must also be specified.

*Track Group Size:* This optional parameter of the SPOOL operand changes the size of the track groups within the spooling disk area. Valid sizes that can be specified at IPL are 1, 2, 4, 5, and 10. This parameter overrides the value specified during system generation only when NEW is specified, and it remains in effect until that spooling disk area is reformatted or a new area is built on the disk pack. Whenever track group size is specified, NEW must also be specified.

*RDR (R):* This operand activates the input spooling routine that reads from the spooled reader and places the jobs in the reader queue. This operand is used to start the spooled reader following IPL or after the reader has been terminated. Spooling must be active prior to entering a START RDR command and the punch writer must not be active.

*ROLL:* The optional ROLL parameter allows cards read on the MFCU to be placed in each of the four stackers before operator intervention is required. Stopping the reader with the STOP RDR command and then restarting without the ROLL parameter causes all the cards read to be placed in only one stacker.

*PRT (W):* This operand activates the print writer so printing of spooled records from the print queue can begin when the spooled printer is available. The PRT operand starts the print writer following IPL or after the print writer has been terminated. If used after a STOP command, printing begins at the point at which the writer was terminated. Spooling must be active prior to entering a START PRT command.

*Forms Type:* When the forms type operand is supplied, the print writer prints only those job steps in which the forms type matches that given in the START command. For example, START PRT,ABC causes only those job steps in which the forms type is ABC to be printed. To change the forms type, the print writer must be terminated (STOP PRT), and a new START command specifying different forms type must be entered. If the print writer is started without the forms type operand, it prints job steps in the order in which they occur on the print queue.

*PCH (P):* This operand activates the punch writer so punching of spooled records from the punch queue may begin when the spooled punch device is available. This operand starts the punch writer following IPL or after the punch writer has been terminated. When used after a STOP command, punching begins at the point in which the writer was terminated. Spooling must be active prior to entering a START PCH command, and the reader must not be active.

*P1, P2, or P3 (5704-SC2 only):* These operands are used to start program execution in a partition in which execution was stopped by a STOP command. The START Px command can be entered at any time and takes effect immediately.

## START Command (Continued)

### Considerations

If the START SPOOL command is not entered following IPL, the system activates spooling according to the specifications given during system generation. This command is valid only on systems that support spooling.

If START PRT or START PCH is entered while the respective writer is active, the START command is ignored.

Once a disk drive has been specified as the spool unit, the disk pack on that drive should not be removed (unless an IPL procedure is to be performed) even though all of the spooling functions have been terminated.

Consider the following examples:

1. START SPOOL,NEW,D1,50,5  
or  
S SP,NEW,D1,50,5

This command, given at IPL, reformats the spool area on disk. Existing data in the spool file is lost. The spool data area is built on drive 1, is 50 cylinders in size, and has a track group size of 5 tracks. The operator will be informed by the display if previous data exists in the spool file.

2. START SPOOL,,D1  
or  
S SP,,D1

If there is any data in the spool queues, this command, given at IPL, does not reformat the spool area on disk; the number of cylinders used for spooled data is not changed. If there is no data in the spool queues, the spool area is reformatted, and the number of cylinders and track group size are the values specified during system generation. In either case, the disk unit is D1.

3. START SPOOL,P2  
or  
S SP,P2

If spooling is stopped in partition 2, this command starts spooling in partition 2 after the next end of job (not end of step).

## STOP Command

### Function

- Terminates spooling in a partition.
- Terminates the reader, print writer, or punch writer.

*Note:* The preceding functions are valid only for systems that support spooling.

- Stops program execution in a partition (5704-SC2 only).

### Format

Operation	Operand
STOP (P)	SPOOL {,P1 (SP) {,P2 {,P3
RDR (R)	
PRT (W)	[,STEP (ES) ,PAGE (PG)]
PCH (P)	[,STEP (ES)]
P1 P2 P3	

### Contents

**SPOOL (SP):** This operand causes spooling to be terminated in the specified partition: partition 1 (P1), partition 2 (P2), or partition 3 (P3). After IPL, the STOP SPOOL command can be entered at any time following initiation of spooling. The command takes effect at the next end of job (not end of job step) when the system input device is released. The command takes effect immediately if it is entered at end of job. Spooling remains stopped in that partition until a START SPOOL command is entered in the partition. When spooling has been stopped, jobs execute in the same manner as in a system without spool support; that is, the jobs use the unit-record devices directly.

**RDR (R):** This operand causes the input spooling routine (reader) to terminate immediately, releasing the input device for other use. The job currently being spooled is not put on the reader queue.

**PRT (W):** This operand causes the print writer to terminate, releasing the printer for other use. The job step currently being printed is kept on the queue; it can be continued from the point of interruption using a START PRT command, or the print writer can be started from the beginning of any page using a RESTART command.

**STEP (ES):** This operand causes the print writer to delay termination until the current step or copy is completed and removed from the queue. If the print writer is already at the end of a step, it ignores this operand and terminates immediately.

## STOP Command (Continued)

### Contents (Continued)

*PAGE (PG):* This operand causes the print writer to delay termination until the current page is completed. If the print writer is at the end of a print step, it ignores this operand and terminates immediately.

*Note:* If neither the STEP nor the PAGE operand is entered, the print writer terminates immediately.

*PCH (P):* This operand causes the punch writer to terminate, releasing the punch device for other use. The job step currently being punched is kept on the queue; it can be continued from the point of interruption using a START PCH command, or it can be started from the beginning using a RESTART PCH command.

*STEP (ES):* This operand causes the punch writer to delay termination until the current step or copy is completed and removed from the queue. If the punch writer is already at the end of a step, it ignores this operand and terminates immediately. If this operand is not entered, the punch writer terminates immediately.

*P1, P2, or P3 (5704-SC2 only):* These operands are used to stop program execution in a partition. This command cannot be entered for the partition in which the communications control program (CCP) is executing or when a partition is using certain system resources, such as the system interlocks. This command takes effect immediately. A START command is required to resume program execution after it has been stopped.

*Note:* The STOP Px command can also cause the spool writers to stop execution if they are printing or punching data from the job step when it is stopped. They will resume printing or punching after execution has been started in the partition.

### Considerations

Once a disk drive has been specified as the spool unit, the disk pack on that drive should not be removed (unless an IPL procedure is to be performed) even though all of the spooling functions have been terminated.

If the print or punch writer is producing output for a job step that is currently executing and a STOP writer command is entered while the writer is waiting for more data from the job step, the writer is not stopped until the job step produces the required data for the writer or until the job step completes.

You should respond to any I/O error messages before entering the STOP RDR, STOP PRT, and STOP PCH commands. The STOP command is not executed until you have responded to these I/O error messages.

Consider the following example:

```
STOP SPOOL,P1  
or  
P SP,P1
```

This command causes spooling to be terminated when partition 1 is at end of job (not end-of-job step).

## TIME Command

### Function

Sets the system time. The system time is set to 00:00:00 after the IPL procedure unless this command is entered.

### Format

Operation	Operand
TIME (TM)	{ hh:mm:ss } { hhmmss }

### Contents

*hh*: This operand specifies the hour. The hour must be two characters from 00 through 23.

*mm*: This operand specifies the minute. The minute must be two characters from 00 through 59.

*ss*: This operand specifies the second. The second must be two characters from 00 through 59.

### Considerations

All partitions must be at end of job and a rollin cannot be pending when this command is entered, or CAN NOT ACCEPT is displayed. The time can be entered with or without punctuation. Punctuation can be any characters except numbers, commas, or blanks.

When the system time passes 23:59:59: the system date is automatically updated to the next date. See the *IBM System/3 Model 15 System Control Programming Reference Manual*, GC21-5077 (5704-SC1), or the *IBM System/3 Model 15 System Control Programming Concepts and Reference Manual*, GC21-5162 (5704-SC2), for considerations when using the system date in your programs.



## TLOG Command

### Function

Activates or deactivates the transaction logging function.

### Format

Operation	Operand
TLOG (TL)	{ ON } { OFF }

### Contents

*ON*: If transaction logging is inactive, this operand causes header labels to be written on the newly mounted tape and activates transaction logging.

*OFF*: If transaction logging is active, this operand writes trailer labels, rewinds the current tape, and deactivates the transaction logging function.



- Responding to System Messages
- Using the Register Display Unit
- Stopping a Job Before Completion
- Dumping Main Storage
- Turning System Power Off
- Restoring System Power

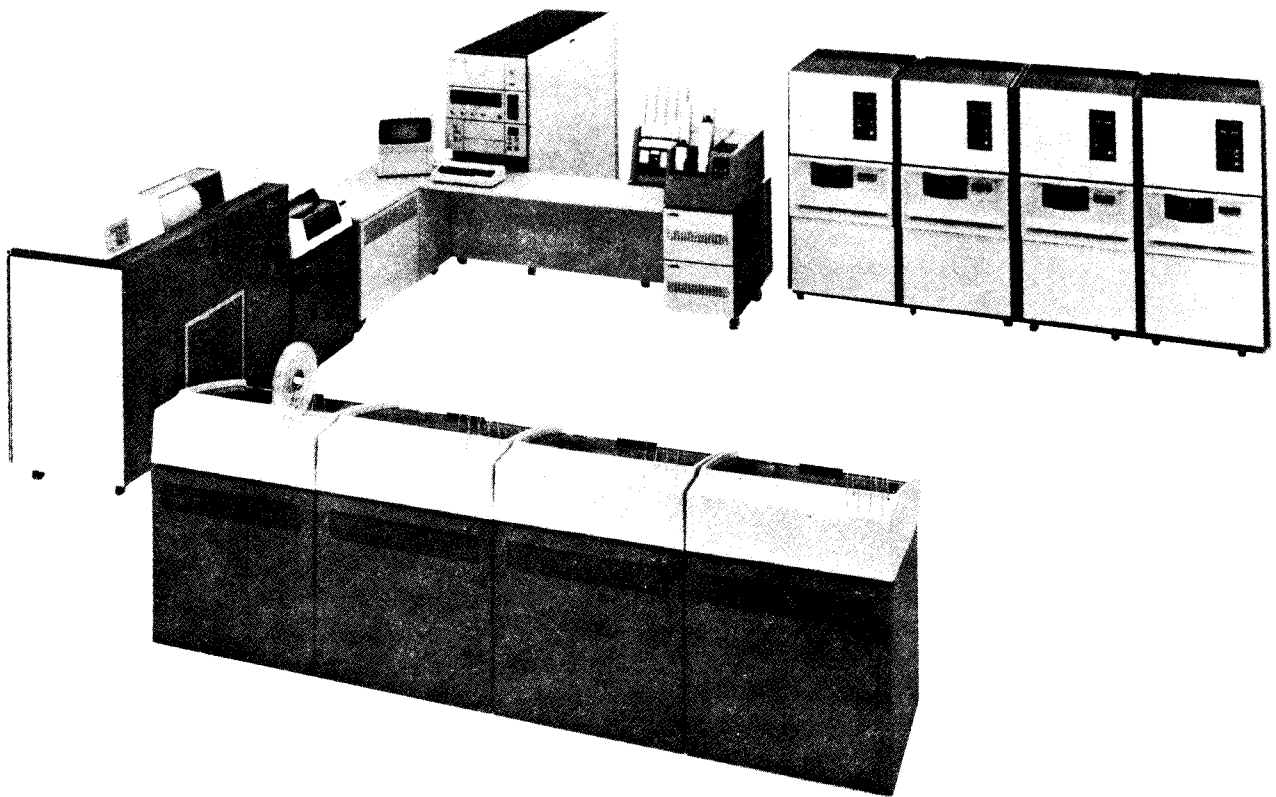

## RESPONDING TO SYSTEM MESSAGES

System/3 Model 15 displays messages on the CRT screen to indicate incorrect program operation, machine errors, or information or instructions to tell you what is needed next. Information messages normally do not require any response other than pressing ENTER to remove the message from the screen. Any other messages should be responded to as quickly as possible to ensure that processing continues in all partitions. Failure to respond to a system message issued by one partition can cause the other partitions to become inactive due to the unavailability of a system resource.

Messages contain a message code, related information codes, and possibly message text. The message is displayed on one or more lines on the CRT screen, depending on the information presented.

When the message requires a decision or action, you respond via the keyboard. Your response is displayed on the CRT screen and the message and your response are stored in the system history area on disk. For more information about system messages and individual explanations of all the system messages, see *IBM System/3 Model 15 System Messages*, GC21-5076.

1. Perform any action required to satisfy the condition causing the message.
2. Press the PF12 key.
3. Position the cursor to the response area for the proper message (if the cursor is not already correctly positioned).

*Note:* If the message you are responding to does not contain options, you do not have to perform step 4. Any character specified will be allowed by the system when you press ENTER. Check your program run sheet for a response that might be expected by the program.

4. Enter the option desired.
5. Press the ENTER key.

*Note:* If an invalid response is entered, a question mark (?) is displayed briefly in the response position. You must then enter a correct response. If two or more messages are pending for the same partition and one of these messages allows only a 3 option, you must respond to one of the messages for that partition with a 3 option. If you enter any other option, the number sign (#) is displayed briefly and you must respond with a 3 option.

## Forced Responses

A forced response situation occurs when 10 messages have been issued on the screen to which you have not responded. At this time, ENTER RESPONSE is prompted and you must respond to one of the messages before any more messages can be displayed. This situation can usually be avoided by entering the IDELETE command before 10 unresponded-to messages have been displayed.

## Scrolling System Messages

Follow this procedure to scan previously displayed system messages.

1. Press PF12. The cursor is positioned at the latest message on the first page of messages.
2. Press PF12 again to scan the next page of messages (if more exist).

When the last page of messages has been displayed, pressing PF12 again displays the first page of messages again.

## USING THE REGISTER DISPLAY UNIT

When an error occurs, or when the programmer requests it, you will have to record the system status information from the register display unit lights on the system control panel. The *Messages* manual or the program run sheet will indicate when this is necessary and what information to record.

To display the status information, set the rotary switch at the left of the register display unit and the LSR DISPLAY SELECTOR on the CE panel at the top of the processing unit to the appropriate positions, as described in the Error Log Sheet (Figure 43). Then, record the lighted positions.



**SYSTEM/3 S415 MODEL B  
ERROR LOG SHEET**

Date: \_\_\_\_\_ Time: \_\_\_\_\_  
 Operator: \_\_\_\_\_  
 Job Name: \_\_\_\_\_

Use this sheet to record console display at any unrecognizable halt or processor check

1. Press the STOP key.
2. X all console lights that are on.
3. X any console switch settings requested.
4. X any MFCU lights that are on.
5. Set LSR display selector to NORM. Set console display selector to "1 SAR HI". X all insert blocks with corresponding indicators (P6421) on. Repeat for positions 2 through 8.
6. Set LSR display selector to ARR. Set console display selector to "2 LSR HI". X any indicators that are on.
7. Set LSR display selector to IAR. Set console display selector to "2 LSR HI". X any indicators that are on.

Comments: \_\_\_\_\_

(Continue on back)

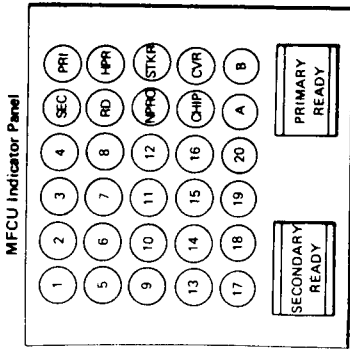

Processing Unit Serial Number: \_\_\_\_\_

Enter Meter Reading: \_\_\_\_\_

LSR DISPLAY SELECTOR

ADDRESS COMPARE CHECK

I/O CHECK

(NORM) (IAR) (ARR) (XR1) (XR2)

All of the above switches are normally in the down position. X any switch that is in the up position.

CONSOLE DISPLAY SELECTOR Note: X block if corresponding indicator is on

1 SAR HI	7 P	0	1	2	3	4	5	6	7	P	0	1	2	3	4	5	6	7	SAR LO	1
2 LSR HI	7 P	0	1	2	3	4	5	6	7	P	0	1	2	3	4	5	6	7	LSR LO	2
3 OP REG	P	0	1	2	3	4	5	6	7	P	0	1	2	3	4	5	6	7	O REG	3
4 B REG	P	0	1	2	3	4	5	6	7	DIG	RE	ADD	SUB	TEMP	AND	OR	ALU CTRL	4		
5 A REG	P	0	1	2	3	4	5	6	7	P	0	1	2	3	4	5	6	7	ALU OUT	5
6 ATT	P	0	1	2	3	4	5	6	7	BIN	TE	DEC	HI	LO	EO	COND	REG	6		
7 CS ASNMT	P	0	1	2	3	4	5	6	7	INT	INT	INT	EA	1	0	STOR	MASK	7		
8 PROC CHK	I/O	LSR	SAR	MSAR	INVT	STOR	ADDR	PROT	SDBI	SDBO	CAR	DBI	AB	ALU	OP	OP	OP	OP	OP	OP

Set LSR DISPLAY SELECTOR to ARR

2 LSR HI	7 P	0	1	2	3	4	5	6	7	P	0	1	2	3	4	5	6	7	LSR LO	2
----------	-----	---	---	---	---	---	---	---	---	---	---	---	---	---	---	---	---	---	--------	---

Set LSR DISPLAY SELECTOR to IAR

2 LSR HI	7 P	0	1	2	3	4	5	6	7	P	0	1	2	3	4	5	6	7	LSR LO	2
----------	-----	---	---	---	---	---	---	---	---	---	---	---	---	---	---	---	---	---	--------	---

MACHINE CYCLE CLOCK

(I/O) (OP) (IR) (XR) (INT) (IL) (XZ) (HZ) (LZ) (EA) (EB) (I/O) (INT) (LEV) (PWR) (CHK)

Enter ADDRESS/DATA switch setting in circle

SIOC

MLTA BUSY

MLTA

MLTA CHECK

BSCA-1

BSCA-2 DISPLAY SELECT

Program Load

Processor Check

ON PWR OFF

I/O ATTENTION

START

STOP

DISK1 F1

DISK1 R1

ALTERNATE

G229-8092-0

Figure 43 (Part 2 of 3). Model 15B Error Log Sheet (G229-8092)

SYSTEM/3 5415 MODELS C AND D  
ERROR LOG SHEET

Date: \_\_\_\_\_ Time: \_\_\_\_\_  
Operator: \_\_\_\_\_  
Job Name: \_\_\_\_\_

Use this sheet to record console display at any unrecognizable halt or processor check.

1. Press the STOP key.
2. X all console lights that are on.
3. X all console switch settings requested.
4. X any MFCU lights that are on.
5. Set LSR display selector to NORM. Set console display selector to "1 SAR HI". X all insert blocks with corresponding indicators (PB21) on. Repeat for positions 2 through 8.
6. Set LSR display selector to ARR. Set console display selector to "2 LSR HI". X any indicators that are on.
7. Set LSR display selector to IAR. Set console display selector to "2 LSR HI". X any indicators that are on.

Comments: \_\_\_\_\_  
\_\_\_\_\_  
\_\_\_\_\_  
\_\_\_\_\_ (Continue on back)

MFCU Indicator Panel

1	2	3	4	SEC	PRI
5	6	7	8	RD	HPR
9	10	11	12	NPRO	STKR
13	14	15	16	CHIP	CVR
17	18	19	20	A	B

SECONDARY READY      PRIMARY READY

Processing Unit Serial Number: \_\_\_\_\_

Enter Meter Reading: \_\_\_\_\_

DT SET READY  
BSCA ATTN  
BSCA2 ATTN  
TSM MODE  
TSM CLEAR MODE  
RECEIVE CHAR MODE  
RECEIVE INT'L MODE  
DIS-PROL MODE  
ACT SWP DISK

DT SET READY  
TSM TEST SW  
TSM CLEAR MODE  
RECEIVE CHAR MODE  
RECEIVE INT'L MODE  
DIS-PROL MODE  
ACT SWP DISK

MLTA ATTN  
MLTA BSY  
MLTA CHECK

BSCA-1 DISPLAY SELECT

BSCA-2 DISPLAY SELECT

ADDRESS I/O CHECK  
COMPARE CHECK

IAR NORM XRI XP2  
ARR

LSR DISPLAY SELECTOR

All of the above switches are normally in the down position. X any switch that is in the up position.

1 SAR HI	5 6 7	P 0 1	2 3 4 5 6 7	P 0 1	2 3 4 5 6 7	SAR LO 1
2 LSR HI	5 6 7	P 0 1	2 3 4 5 6 7	P 0 1	2 3 4 5 6 7	LSR LO 2
3 OP REG		P 0 1	2 3 4 5 6 7	P 0 1	2 3 4 5 6 7	Q REG 3
4 B REG		P 0 1	2 3 4 5 6 7	DIG RE ADD SUB CAR COMP	TEMP AND OR	ALU CTRL 4
5 A REG		P 0 1	2 3 4 5 6 7	P 0 1	2 3 4 5 6 7	ALL OUT 5
6 ATT		P 0 1	2 3 4 5 6 7	BIN TE DSC OVF HI LO EQ	COND REG 6	
7 CS ASMT		P 0 1	2 3 4 5 6 7	IO EA I PRIV I O STOR MASK INT PMR 7	PROT INT	
8 PROC CHK		P 0 1	2 3 4 5 6 7	I/O SAR MSAR INV STOR ADDR PROT SOB SDBO CAR DBI AIB ALU CPU OP INV CHAN INV PROC CHK 8	OP DBO O	

Set LSR DISPLAY SELECTOR to ARR

2 LSR HI	5 6 7	P 0 1	2 3 4 5 6 7	P 0 1	2 3 4 5 6 7	LSR LO 2
----------	-------	-------	-------------	-------	-------------	----------

Set LSR DISPLAY SELECTOR to IAR

2 LSR HI	5 6 7	P 0 1	2 3 4 5 6 7	P 0 1	2 3 4 5 6 7	LSR LO 2
----------	-------	-------	-------------	-------	-------------	----------

SAR/LSR HI Extended: 5 6 7

MACHINE CYCLE: IOP IO IR IX1 IH1 IL1 IX2 IH2 IL2 EA EB

CLOCK: 0 1 2 3 4 5 6 7 8 9

SIOC

Enter ADDRESS/DATA switch setting in circle

BSCC

BSCC 1 BSCC 2

HALF HALF BSCC 1 BSCC 2

DT TERM READY  
SEND/REC DATA  
TSM MODE  
RECEIVE MODE

EXT TEST SW  
CLEAR TO SEND  
RECEIVE INITIAL  
UNIT CHECK

Figure 43 (Part 3 of 3). Model 15C-D Error Log Sheet (G229-8091)

## STOPPING A JOB BEFORE COMPLETION

You can stop a job before it reaches end of job by:

- Responding to a system message with either a 2 or 3 option (if these are valid for the particular message).
- Entering the CANCEL command, specifying the partition in which the job is executing.
- Entering the DUMP command, specifying the partition in which the job is executing.

### Entering a Cancel Option

Three types of cancel procedures are available when using a cancel option in response to a system message. The controlled cancel is indicated by the 2 option. It causes control to be returned to the program which may then close files and perform other end-of-job functions before canceling the program.

The 3 option causes an immediate cancel. Control is given to the system, which cancels the job. For most messages where option 2 or 3 is selected, the job or job step is canceled with no further action being taken. The message indicates the corrective action the programmer should take before the job or job step is resubmitted.

If a 2 or 3 option is taken to a system message during a \$MAINT run, the library or library entries involved in the function might be destroyed.

The D option causes an immediate cancel with a dump of the associated partition. This option can be substituted for the 3 option for any message associated with partition 1, partition 2, or partition 3.

### Considerations When Selecting 2 Option

*Job Mode:* When the 2 option is selected in response to a system message and the partition is in job mode, all remaining steps in the job are also canceled. On systems that support input spooling, job processing in the partition resumes with the next job on the reader queue. On systems where spooling is not active, the system job stream is read but not processed until a JOB or /. OCL statement is read. If output spooling is supported on the system, spooled output created by the job is saved.

*Step Mode:* When the 2 option is selected to a system message and the partition is in step mode (spooling is not active), only the current job step is canceled. The system input job stream is read but not processed until a JOB, LOAD, CALL, /., or /& OCL statement is read.

When a message is displayed during the execution of a job step and the 2 option is selected, the disk files reflect all activity up to the point when the message occurred and the 2 option was selected. However, if the system message occurs during a \$MAINT run, the selection of the 2 option does not cause the library or library entries involved in the function to be retained.

### Considerations When Selecting the 3 Option

*Job Mode:* When the 3 option is selected and the partition is in job mode, all remaining steps in the job are canceled. On systems that have input spooling, job processing in the partition resumes with the next job on the input queue. On systems where input spooling is not active, the system input job stream is read but not processed until a JOB or /. OCL statement is read. If output spooling is supported on the system, spooled output created by the job is saved.

*Step Mode:* When the 3 option is selected to a system message and the partition is in step mode, only the current job step is canceled. The system input stream is read but not processed until a JOB, LOAD, CALL, /., or /& OCL statement is encountered.



When a message occurs during the execution of a job step and the 3 option is selected, the status of the disk files being used by the program depends on the operations being performed. The possible dispositions of the disk files are:

- New files being created are not retained.
- Old files being deleted are retained.
- If SHARE-YES was specified, old files being added to will reflect the additions that have been written to the disk up to the point at which the CANCEL command occurred.
- Old files being added to do not reflect the additions if SHARE-NO was specified on the FILE statement.
- Old files being updated reflect the updates that have been written to the disk at the point at which the message occurred.

### Entering the CANCEL Command

At times, you may determine that it is necessary to cancel an executing job or job step even though no system message has been displayed that allows cancellation. In this case, you enter the CANCEL command specifying the partition in which the job or job step is executing.

$$\text{CANCEL (CN)} \left\{ \begin{array}{l} \text{P1} \left[ \begin{array}{l} .2 \\ \hline .3 \end{array} \right] \\ \text{P2} \left[ \begin{array}{l} .2 \\ \hline .3 \end{array} \right] \\ \text{P3} \left[ \begin{array}{l} .2 \\ \hline .3 \end{array} \right] \end{array} \right\}$$

*P1, P2, or P3:* This operand indicates the partition in which the job or job step is executing. (P3 is for 5704-SC2 only.)

*2 or 3:* This operand specifies the cancel option to be used. These cancel options cause the same results as entering a 2 or 3 option in response to a system message, except that control is not returned to the program to perform end-of-job functions. (See the previous discussion.) If neither option is specified, the 2 option is assumed and a controlled cancel occurs.

### DUMPING MAIN STORAGE

When a dump of main storage is necessary, you enter the DUMP command. With this command, you can dump the contents of either partition or the entire system. The program executing in the area that is dumped is canceled according to the option you specify. If you dump all of main storage, a PL halt appears on the message display unit when the dump is complete. You must press START on the system control panel to continue. Figure 44 shows an example of the output from the DUMP command.

The format of the DUMP command is:

$$\text{DUMP (K)} \left\{ \begin{array}{l} \text{P1} \left[ \begin{array}{l} .2 \\ \hline .3 \end{array} \right] \\ \text{P2} \left[ \begin{array}{l} .2 \\ \hline .3 \end{array} \right] \\ \text{P3} \left[ \begin{array}{l} .2 \\ \hline .3 \end{array} \right] \\ \text{SYSTEM } [.,\text{DISK}] \\ \text{(S)} \end{array} \right\}$$

*P1, P2, or P3:* This operand specifies a partition to be dumped. (P3 is for 5704-SC2 only.)

*2 or 3:* This operand indicates the cancel option to be used. All the functions of the cancel options, as explained under *Stopping A Job Before Completion*, apply to the DUMP command.

*SYSTEM:* This operand indicates that the entire contents of main storage are to be dumped. The output from this operation cannot be spooled.

*DISK (5704-SC2 only)*: This operand specifies that the following are to be written to a user-provided disk file called \$SYSDUMP (see Appendix F):

- Entire contents of main storage
- Scheduler work areas for P1, P2, and P3
- Saved transient area, if available
- Part of the system history area
- System and CCP configuration records (5704-SC2 only)
- PTF log sectors from system and CCP packs (5704-SC2 only)
- 3340, BSCC, and display adapter microcode levels (5704-SC2 only)
- Outboard and statistical error recording data (5704-SC2 only)
- Disk and tape error recording data (5704-SC2 only)

The contents of \$SYSDUMP can be printed at a later time if you run the \$CPRINT program (see Appendix G).

*Note:* If unable to use the procedure described above:

- Press SYSTEM RESET.
- Set leftmost address switch to F.
- Press START.

This dumps all of main storage to the printer. Refer to *IBM System/3 Model 15 System Data Areas and Diagnostic Aids*, SY21-0032 for 5704-SC1 or SY21-0052 for 5704-SC2, for other CEFE dump procedures.

The IPL process must be performed again to continue processing.

PARTITION 1 STORAGE DUMP } Identifies the contents of the dump (partition 1, partition 2, or partition 3).  
 EJ COMPLETION CODE - 0000 } Identifies the cause of the dump. See Part 2 of this figure.  
 TCB ADDRESS - 1FD4 } Provides the address of the Task Control Block.

TASK CONTROL BLOCK

PRB  
 20EF40C0 00430000 1B000000 1FD44220 00780124 41754106 451E93D0 00850000  
 C0000000 00031651 0E000000 001FD42A 29282726 25242322 21201F1E 1D1C1B1A  
 19181716 15141307 06050400 00000084 2C2CC040 40404040 4040405B D4C1C9D5  
 E3F0F15B D4C1C9D5 E33BC7B9 00FFFFF0 98000198 00400000 0093D02F 80000000  
 00A90010 F0F5F1F3 F7F60232 CC100202 00A90880 00004000 00000000 00000000  
 84010000 0000268C 00268C00 26900000 00842C26 80001EB9 F0E1E8E9 00000000  
 00C08098 00000000 00000000 00000000 00000000 00000000 00000000 00000000  
 00000000 00000000 00000000 00C02694 00269400 00000000 00000000 00000000  
 00000000 00000000 00000000 00000000 00000000 00000040 404040FF FF01FF40

DUMP TRANSIENT RB

1C400080 1FD40D0F 00681004 1B1D1A40 09F53304 0703D400 00000000 001A4000 } Request block for system  
 FF000000 00000000 0000001A 7C422000 78012441 75410645 1E000000 00000001 } dump transient (\$\$STCO).

ERROR MESSAGE RB

1CC00080 1FD4091C 00680202 1FD41FD4 097C4030 07D4C000 00000000 001BC000 } Request block for error  
 00000000 00000000 00000000 00000000 00000000 00000000 00000000 00000000 } message transient (\$\$SPEE).

EJ TRANSIENT RB

1FD40080 1FD408B6 00680121 1CDD1FD4 00368794 07C08400 00000000 00403006 } Request block for EJ  
 08001C08 00038000 01071200 001FD400 38FB4207 0000E4FC 001C4241 75C0DF08 } transient (\$\$SPEJ).

ACTIVE RB AT EJ IS PRB Storage location in hexadecimal.

PRB IAR-4220 PMR-0078 PSR-0124 XR2-4175 XR1-4106 ARR-451E } Register contents.

0000 35200013 F4100000 F06F7F01 F06F6C00 01106FFE 3F1D0000 00000000 00000000  
 0020 00000000 00000000 0002571F D41FD400 4555F410 00C4F410 00088F43 000000C2  
 0040 00D40036 2109379B 00000002 A41A40FF FF1B0000 00400040 0068801D 57000000  
 0060 001A7C00 0000EE00 00000000 00010000 00004000 C010384B 00691FD4 384B38A3  
 0080 5A6E581E 00400000 00000000 15000000 52000800 84110100 00000019 150000F4  
 00A0 30683540 00AC3520 00AB0800 36F43070 C0870000 F43079C0 870000F4 3070C087  
 00C0 00003408 00D3F430 09C08746 26F43079 C0870000 F430093A 80002FC0 873F1D00  
 00E0 00000000 00000000 F00000F0 5D6F3000 00F33401 00EA0C00 00EC00EA C08700E8  
 0100 00000000 00000000 00000000 00000000 1FD41EB9 1D004BAA 002B0000 00070000  
 0120 002680A9 2F80F0F5 F1F3F7F6 738000B8 379B379B 39AA38FB 01830320 1F000FFE  
 0140 400001E8 00807F00 00000000 00000000 00000000 00000007 7B408090 80800080  
 0160 80808000 00000000 00000000 00009800 43D00001 50F503F8 00004D5C 1D9E0000  
 0180 00000000 EE00EE01 9201BC2A 00200000 005A018D 018D018D 018D018D 018D018D  
 01A0 018D018D 018D018D 018D018D 018D1CAC 018D02C5 018D018D 018DFFFF 00000000  
 01C0 00000000 00000000 00000000 00000000 00000000 00000000 1C800000 00000000  
 01E0 00000000 FFFF01E8 00EE00D4 1A4000E8 0000037B 00000000 00000000 00000000  
 0200 00000000 00000000 00000000 00000000 00000000 00000000 00000000 00000000

DUPLICATE LINES

Hex representation of storage. The user program usually begins at location 4000.

Figure 44 (Part 1 of 2). Sample Dump Output

**This page is intentionally left blank.**

## EJ Completion Codes

1st Byte		2nd Byte	
Contents	Meaning	Contents	Meaning
X'80'	Dump requested.	X'0E'	INVALID SIMULATION ACCESS TO MDA.
X'40'	System code (see byte 2).	X'0D'	INVALID 3340 ACCESS TO SIMULATION AREA.
X'20'	Reserved.	X'0C'	INVALID 5444 SECTOR.
X'10'	Dump called by a DUMP command.	X'0B'	INVALID 5444 CYLINDER.
X'08'	System code (see byte 2).	X'0A'	INVALID 5444 OPERATION.
X'04'	Reserved.	X'09'	INVALID FREE REQUEST.
X'02'	Insufficient storage.	X'08'	RELOCATING BUT NO RLD'S FOUND.
X'01'	Program check.	X'07'	EXIO TO INVALID DEVICE.
X'00'	Normal completion.	X'06'	INVALID SETON/SETOFF SVC.
		X'05'	LOAD ABOVE PARTITION END ADDRESS.
		X'04'	LOAD BELOW PARTITION START ADDRESS.
		X'03'	I/O PROTECT VIOLATION.
		X'02'	INVALID DEQU SVC.
		X'01'	INVALID ENQU SVC.
		X'00'	No secondary error code.

Figure 44 (Part 2 of 2). Sample Dump Output

## TURNING SYSTEM POWER OFF

Before you turn system power off, an end-of-job message should be displayed on the CRT screen for all partitions. The spool reader, print writer, and punch writer should also be stopped. Perform the following procedures to turn system power off:

1. Press console STOP.
2. Set START/STOP switches on the disk panels to STOP.
3. Clear cards from the card reader.
4. Press RESET and UNLOAD REWIND on all tape units.
5. When the OPEN lights on the disk panel are on and tapes have been rewound, set the console POWER switch to OFF.

*Note:* The 3741 directly attached to System/3 has its own power supply and is powered on and off independently of the system. The 3741 should not be powered off until an end-of-job message is displayed on the CRT screen. The 3741 should be powered on when the system is powered on. To turn the 3741 on or off while a program is running, the system could be temporarily stopped and then restarted by pressing the STOP and START keys on the CPU.

If system power is turned off before the disk panel START/STOP switches are set to STOP, perform the following procedures:

1. Set the console POWER switch to ON and wait for the READY lights to turn on.
2. Set START/STOP switches on the disk panel to STOP and wait for the OPEN lights to turn on.
3. Set console POWER switch to OFF.

## RESTORING SYSTEM POWER

System/3 Model 15 can turn off as a result of internal or external power loss, or overheated equipment (thermal check) condition in the processing unit or printer electronics. The recovery procedure depends on the status of the TH CHK (thermal check) and PWR CHK (power check) lights on the processing unit display panel.

### PWR CHK Light Only

Power off was caused by voltage loss or overvoltage in the system. To restore power:

1. Turn the console POWER switch to OFF.
2. Press CHECK RESET on the CE control panel.
3. Turn the console POWER switch to ON.

If power cannot be restored, call IBM for hardware support.

### PWR CHK and TH CHK Lights

Power off was caused by a thermal condition or a temporary external voltage loss. If there are any objects (such as boxes, papers, or coats) on or around the processing unit, remove them because they may be interfering with air circulation in the machine. To restore power:

1. Turn the console POWER switch to OFF. The PWR CHK light goes off immediately. The TH CHK light should turn off when the internal temperature in the processing unit lowers to a safe operating level.
2. If the TH CHK light turns off within five minutes, turn the console POWER switch to ON. If it does not turn off within five minutes or if the TH CHK light turns on again soon, call IBM for hardware support.

### No Lights

Check that line voltage is available to the system. Check that the EMERGENCY PULL switch is in the normal (in) position. If the EMERGENCY PULL switch is pulled, call IBM for hardware support.

- Job Mode and Step Mode
- Nonspoiled Operation
- Spooled Operation
- System Input Device Considerations
- Multiprogramming Operating Procedures

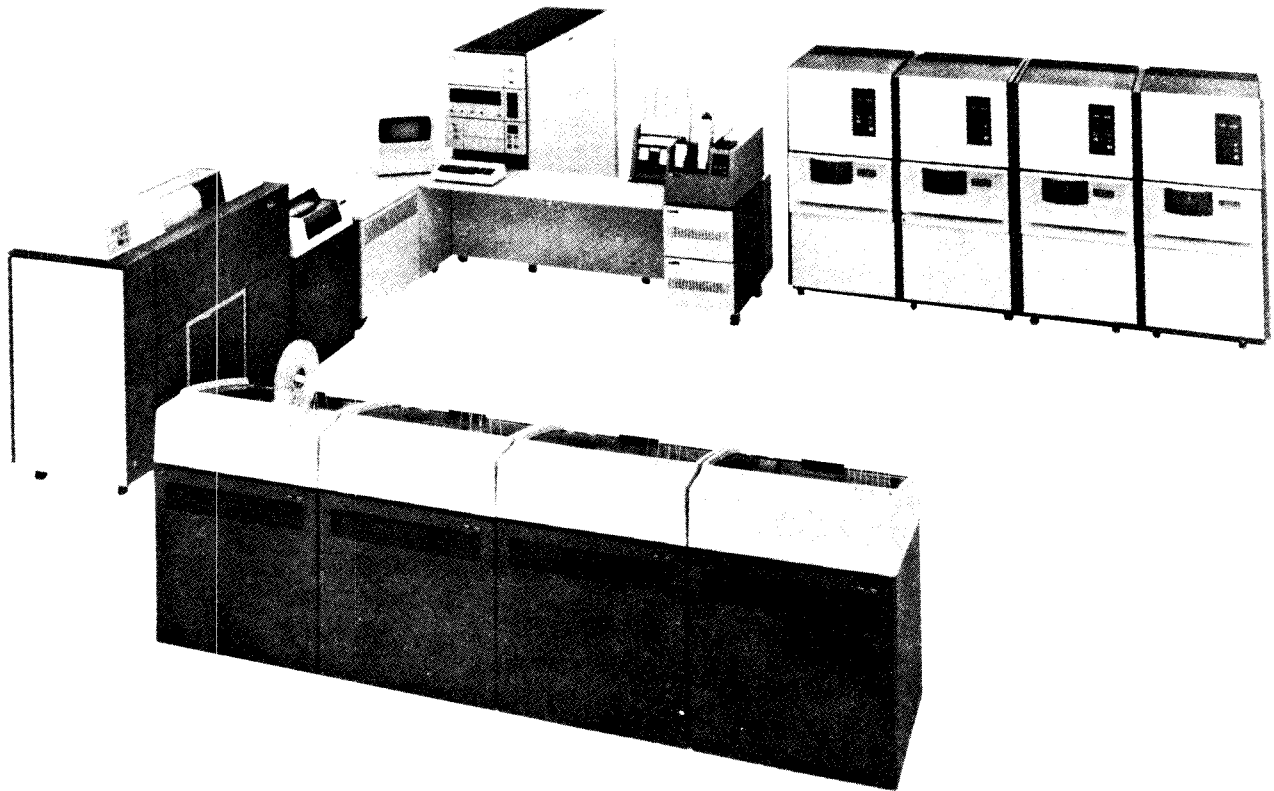

## JOB MODE AND STEP MODE

Your input stream can be in one of two modes: step mode or job mode. Both modes can be used in the multiprogramming environment (all partitions running concurrently) or when only one partition is in use. One partition can be running in job mode while another is in step mode. Only job mode can be used in a partition with active spooling. The OCL you use determines whether or not you are using job mode. A JOB statement indicates the beginning of job mode, and continues until the next JOB or /. OCL statement is encountered.

## NONSPOOLED OPERATION

### Using Job Mode

- OCL statements for all partitions must be entered from separate system input devices unless the CRT/keyboard is used with Program Number 5704-SC2.
- Input and output devices required by the programs must be available. Only the 5444 disk, 5445 disk, 3340 disk, and 3344 disk can be shared by all partitions. Therefore, careful scheduling of jobs is important.
- The system input device assigned to a partition remains assigned to that partition for the duration of the job, even if the job step that is executing does not use the system input device, except when the CRT/keyboard is being used with Program Number 5704-SC2. (See *System Input Device Considerations* later in this chapter.)

When you use job mode, you must place JOB statements in the input stream to define your jobs. A JOB statement indicates to the system that job mode is active and that the system input device assigned to the partition is not released until job mode is terminated. By processing in job mode, you ensure that a group of programs are executed sequentially, in the correct partition, and in a partition that has sufficient main storage to accommodate all steps of the job. You are responsible for initiating the job in the correct partition. When the job is initiated, the system checks the PARTITION and CORE parameters, if specified, on the JOB statement to ensure that the job is initiated in the correct partition and that enough main storage is allocated to the partition to satisfy the CORE parameter. If either of these conditions is not met, the system issues a diagnostic and the job must be canceled. Job mode on nonspooling systems or on systems that do not have input spooling, requires the dedication of a system input device to the partition being run in job mode except the CRT/keyboard being used with Program Number 5704-SC2.

When you want to end job mode and return to step mode, you must place a /. OCL statement in your input stream. A /. OCL statement indicates to the system that job mode is to be terminated and the system input device dedication is no longer required.

### Using Step Mode

- All partitions can share the same system input device; however, only one partition can receive OCL statements and data from the device at any one time.
- Input and output devices required by the programs that are executing must be available. Only the 5444 disk, 5445 disk, 3340 disk, and 3344 disk can be shared, so careful scheduling of jobs is important.
- The system input device assigned to a partition may be available for use by another partition once the OCL statements for a job step are read. The CRT/keyboard is available for use by all partitions prior to reading the OCL statements for a job step when being used with Program Number 5704-SC2.

*Note:* Some programs, such as the RPG II Compiler and Disk Sort, require a dedicated system input device while they execute. Therefore, the system input device is not available to another partition until these programs release it.

When running in step mode, no JOB statements are used to group job steps together. Each set of LOAD/RUN or CALL/RUN statements is processed independently. The system input device is released after the RUN statement is processed and the program is executing. Step mode is not supported in partitions that have spooling support active.

## SPOOLED OPERATION

When you use spooling support, job mode is required. Spooling schedules the jobs to be executed in each partition according to the priority assigned to the various jobs and produces the output from the jobs on the priority basis. You can change the priority of a job on the input queue or the priority of job step output by using the CHANGE priority command.



When operating in the spooled environment, remember:

- With input spooling you can load programs into all partitions from one system input device by using the **PARTITION** parameter in the **JOB** statement. This system input device remains assigned to spooling until the termination of spooled input (see *System Input Device Considerations* later in this chapter).
- You do not have to ensure that spooled input and output devices are available when the programs are executing. The use of these devices is scheduled by spooling.

When the spooling routines encounter a **JOB** statement in the input stream, it indicates the beginning of a new job. The spooling routines use the information on the **JOB** statement when building the input and output queues on disk. The **JOB** statement includes the jobname, which is used by the system to qualify system messages and by you to monitor the job. When input spooling is active, the spooling routines handle job scheduling and job initiation. Jobs are scheduled for execution based upon the priority specified on the **JOB** statement. Spooling ensures that jobs are executed in the requested partition, and that all job steps are executed sequentially in the same partition.

## SYSTEM INPUT DEVICE CONSIDERATIONS

During system generation, you assign a system input device to each partition. When program loading is initiated in a partition, **OCL** statements are read from the system input device assigned to that partition. The system input device for a partition can be changed by a **READER** statement or a **READER** command.

When running in step mode, the system input device is assigned to a partition while the **OCL** statements are being processed. After the **OCL** statements are processed, the system input device may be allocated to any partition. When an error condition occurs during a program and a 2 or 3 option is taken, the job stream in the system input device is read but not processed until a **LOAD**, **CALL**, **JOB**, **/.**, or **/&** **OCL** statement is found. Unless a **/.** or **/&** **OCL** statement is found, the system input device is not released. The **CRT**/keyboard is available for use by all partitions prior to reading the **OCL** statements for a job step when being used with Program Number 5704-SC2.

*Note:* Some programs, such as the **RPG II** compiler and **Disk Sort**, require a dedicated system input device while they execute.

When running in job mode with spooling inactive, the system input device is assigned to a partition for the duration of a job. Once a **JOB** statement is processed in a partition, the system input device for that partition remains assigned to the partition until a **/.** **OCL** statement is encountered.

When running in job mode with spooling active, one input device is assigned as the spooled device, from which all input is read for all spooled partitions. This device can be the same as the system input device assigned to one of the partitions.

When **nohalt** mode is used with job mode, the system input device is not released until halt mode is established and end of job occurs.

## MULTIPROGRAMMING OPERATING PROCEDURES

These procedures also apply to running a dedicated system except that you would only be starting execution in one partition.

### Nonspooled Operating Procedures

1. Perform the **IPL** process.
2. If spooling support is included in your system, cancel spooling by entering the **CANCEL SPOOL** command and set partitions to the desired size if needed.
3. Provide the system date by entering the **DATE** command or using the **DATE** statement if you did not respond to the **DATE** prompt during the **IPL** process.
4. Enter the time of day if the interval timer was specified during system generation.
5. Be sure all necessary **I/O** devices are started.
6. Load the job streams for all partitions in the appropriate system input device (unless one of the system input devices is the **CRT**/keyboard).
7. Respond to the **EJ** message for each partition.

### Spooled Operating Procedures

1. Perform the IPL process.
2. Be sure that the I/O devices required by spooling are started.
3. Provide the system date by entering the DATE command if you did not respond to the DATE prompt during the IPL process.
4. Enter the time of day if the interval timer was specified during system generation.
5. Start any spooling functions that do not have the autostart function by entering the appropriate START commands.
6. Start any I/O devices that are required by the initial programs in the job stream.
7. Respond to the EJ message for each partition.

### System Date Considerations

The date you provide in response to the date prompt, through the DATE statement or through the DATE command, is also used as the program partition date. If time-of-day support is specified during system generation, the system date is automatically updated to the next date when the timer passes 23:59:59. The partition date is reset to the system date whenever the partition is started. Therefore, if the interval timer passes 23:59:59 while a partition is active, that program partition date is not the same as the system date. This is true until the partition reaches end of job and another job is initiated on the partition.

### **Part 3. Program Operation**



This section is an overview of the OCL statements for the Model 15. Figure 45 shows the statements, their functions, and their placement in a job stream or procedure. Figure 46 gives a short description of the parameters for the OCL statements. Complete descriptions for all the OCL statements are provided in *IBM System/3 Model 15 System Control Programming Reference Manual*, GC21-5077 (5704-SC1), or *IBM System/3 Model 15 System Control Concepts and Reference Manual*, GC21-5162 (5704-SC2).

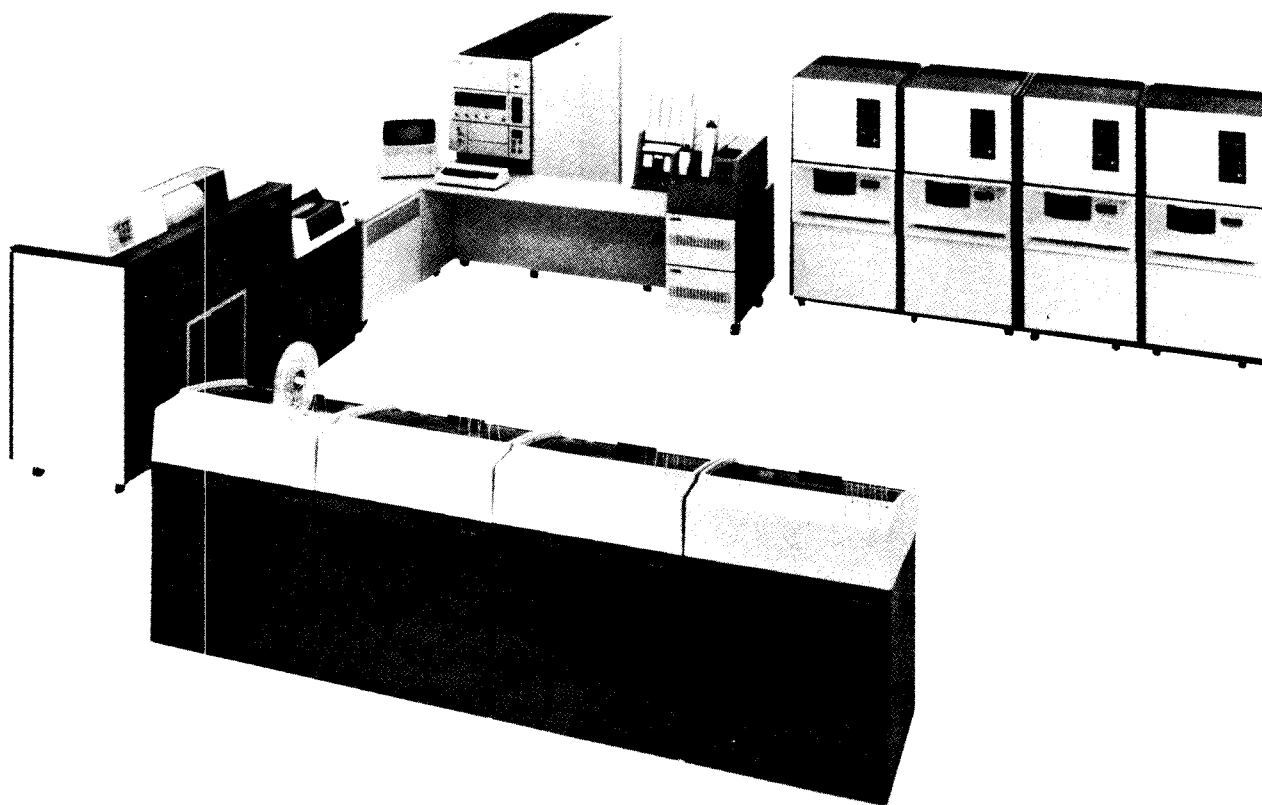

Statement	Function	Placement		Coding Notes
		Statement Appears In Job Stream	Statement Appears In A Procedure	
// ASSIGN	Allows the assignment of a 5444 unit code (R1, F1, R2, F2) to a simulation area (5704-SC2 only).	Anywhere among the OCL statements.	Must precede the RUN statement (if RUN is used).	System pack (R1 or F1) cannot be re-assigned.
// BSCA	Changes the BSCA line number.	Must follow LOAD or CALL statement and precede the RUN statement.	Must follow the LOAD statement and precede the RUN statement (if RUN is used).	None.
// CALL	Identifies procedure to be merged into job stream and disk containing the source library from which to read the procedure.	Must precede the RUN statement. On spooled systems, must follow the JOB statement. Must not be between LOAD and RUN or CALL and RUN.	Indicates chained procedures.	Can be no more than nine levels of nested chained procedures.
// COMPILE	Tells the system where the source program to be compiled is located, and where to place the object program and the link-edit address.	Must follow LOAD or CALL statement and precede the RUN statement.	Must follow the LOAD statement and precede the RUN statement (if RUN is used).	Only one COMPILE statement allowed per job step.

Figure 45 (Part 1 of 5). OCL Statements

Statement	Function	Placement		Coding Notes
		Statement Appears In Job Stream	Statement Appears In a Procedure	
// DATE	1. Change system date and partition dates.	Before first JOB, CALL, or LOAD.	Not allowed.	None.
	2. Change partition date for job.	After the JOB statement and before a LOAD statement (before first step or between steps).	Before LOAD statement.	None.
	3. Change partition date for step.	Must follow the LOAD or CALL statement and precede the RUN.	After LOAD and before RUN.	Cannot be entered if DATE was used to change partition date for job.
// FILE	Supplies information about the file to the system.	Must follow LOAD or CALL statement and precede the RUN statement.	Must follow the LOAD statement and precede the RUN statement (if RUN is used).	Required for every new file created and for existing files being used.
// HALT	Instructs system to halt when program ends; cancels the effect of nohalt mode.	Anywhere among the OCL statements.	Must precede the RUN statement (if RUN is used).	None.
// IMAGE	Tells the system to replace the chain-image area with characters indicated in the data cards that follow or characters keyed in or read from source library.	Anywhere among the OCL statements.	Must precede the RUN statement (if RUN is used).	Required if the printer chain has been changed.
// INCLUDE	Identifies the member in the source library that contains the OCL to be merged into the job stream.	Anywhere among the OCL statements.	Must precede the RUN statement (if RUN is used).	Nested INCLUDE statements are not allowed. Included procedure cannot contain a CALL statement.

Figure 45 (Part 2 of 5). OCL Statements

Statement	Function	Placement		Coding Notes
		Statement Appears In Job Stream	Statement Appears In A Procedure	
//jobname JOB	Allows you to run related job steps together to ensure they are run sequentially.	Must be first OCL statement for a job. Must precede the first LOAD or CALL statement for a job.	Cannot be used in a procedure.	Puts a partition in job mode. Required when using spooling.
// LOAD —or— //stepname LOAD	Identifies the program to be run and indicates the disk that contains the object library from which it is to be loaded.	Must precede the RUN statement when operating in step mode. Must follow the JOB statement when operating in job mode.	Must precede the RUN statement.	None.
// LOAD * —or— //stepname LOAD *	Indicates that the object program will be loaded from the system input device following the RUN statement.	Must precede the RUN statement when operating in step mode. Must follow the JOB statement when operating in job mode.	Must precede the RUN statement. Object program will be read from the system input device.	Cannot run two LOAD * programs concurrently in both partitions (5704-SC1 only). Cannot run a second LOAD * program after a LOAD * program using overlays has been loaded in another partition (5704-SC2 only).
// LOG	Changes the device used for displaying system messages and controls printer ejects before ES messages and before and after EJ messages.	Anywhere among the OCL statements.	Must precede the RUN statement (if RUN is used).	None.
// NOHALT	Instructs system to continue without stopping when a program ends and/or sets the severity level of halts.	Anywhere among the OCL statements.	Must precede the RUN statement (if RUN is used).	None.

Figure 45 (Part 3 of 5). OCL Statements



Statement	Function	Placement		Coding Notes
		Statement Appears In Job Stream	Statement Appears In A Procedure	
// PAUSE	Causes OCL processing to stop in order to give the operator time to perform a function. Operator must restart OCL processing.	Anywhere among the OCL statements.	Must precede the RUN statement (if RUN is used).	This is the only OCL statement displayed on the CRT screen.
// PRINTER	Enables you to describe the functions performed by the system print device and to control options related to spooling.	Anywhere among the OCL statements.	Must precede the RUN statement (if RUN is used).	None.
// PUNCH	Enables you to describe system punch device functions and to control options related to spooling.	Anywhere among the OCL statements.	Must precede the RUN statement (if RUN is used).	None.
// READER	Changes the system input device.	Must precede LOAD or CALL statement or follow the RUN statement and the /* statement (if data cards are present) and must precede the next LOAD or CALL statement.	Must precede the LOAD statement (if LOAD is used).	When used in a procedure, the system input device is changed when the READER statement is processed; but OCL statements are not read from the new system input device until the procedure is completely executed.

Figure 45 (Part 4 of 5). OCL Statements

Statement	Function	Placement		Coding Notes
		Statement Appears In Job Stream	Statement Appears In a Procedure	
// RUN	Indicates the end of the OCL statements for a job step and tells system to run the program.	Must follow the LOAD or CALL statement and be the last OCL statement for a job step.	If used, must follow the LOAD statement and be the last OCL statement in the procedure.	Required in the job stream for each job step which is to be run.
// SWITCH	Used to set one or more external indicators on or off or to leave the indicator as it is.	Must follow LOAD or CALL statement and precede the RUN statement.	Must follow the LOAD statement and precede the RUN statement (if RUN is used).	Only one SWITCH statement allowed per job step.
/&	Acts as a delimiter between job steps.	Recommended as the last OCL statement of a job step.	Not allowed in a procedure.	Not allowed in a procedure.
/.	1. Acts as a delimiter between jobs.	Recommended as the last OCL statement of a job.	Not allowed in a procedure.	Not allowed in a procedure.
	2. With spooling active, two consecutive /. statements indicate end of spooled input.	Last two OCL statements.	Not allowed in a procedure.	Not allowed in a procedure.
	3. With spooling inactive, indicates end of job mode.	Last OCL statement.	Not allowed in a procedure.	Not allowed in a procedure.
*(comment)	Used to explain the job or to give the operator instructions; does not affect program operation.	Anywhere among the OCL statements.	Anywhere among the OCL statements.	Comments are not displayed on the CRT screen.

Figure 45 (Part 5 of 5). OCL Statements

Statement	Parameter	Code	Meaning of Code
// ASSIGN	R1- R2 F1 F2 AREA PACK	D1A, D1B, D1C, D1D, D2A, D2B, D2C, D2D, D3A, D3B, D3C, D3D, D3E, D3F, D3G, D3H, D4A, D4B, D4C, D4D, D4E, D4F, D4G, D4H  AREA-name  PACK-name	Assign (by partition) a 5444 unit code to a simulation area code. (Refer to <i>ASSIGN Statement</i> .)    Name of simulation area to be assigned.  Name of main data area associated with simulation area.
// BSCA	LINE	LINE-1 2	Change all BSCA DTF line codes to the line number specified.
// CALL	procedure name  unit  switch characters	name   5444 unit code  xxxxxxxx	Name that identifies the procedure in the source library.  Specifies the simulation area that contains the procedure.  Unit code for simulation area. Possible codes are R1, F1, R2, F2.  Specifies 8 switch characters that are compared with the eight external indicators. Possible characters are 0, 1, or X.
// COMPILE	SOURCE UNIT  OBJECT  LINKADD  ATTR	SOURCE-name UNIT-5444 unit code  OBJECT-5444 unit code  LINKADD- $\frac{4000}{8000}$  ATTR-MRO  MOV	Name of source program. Specifies the simulation area that contains the source library. Possible codes are R1, F1, R2, F2.  Specifies the simulation area that is to receive the object program. Possible codes are R1, F1, R2, F2.  Linkage Editor: start address (hexadecimal).  Requests that the object program be link-edited to use REMAP mode, memory resident overlays.  Requests that the object program be link-edited to use MOVE mode, memory resident overlays.
// DATE	date	mmddy ddmmy	System date or partition date (domestic date format). System date or partition date (World Trade date format).

Figure 46 (Part 1 of 7). Parameters for OCL Statements

Statement	Parameter	Code	Meaning of Code
// FILE (disk files)	NAME UNIT	NAME-filename	Name the program uses to refer to the file.
		UNIT-5444 unit code	Specifies the simulation area that contains or will contain the file. Possible codes are R1, F1, R2, F2.
	PACK LABEL	UNIT-main data area code	Specifies the main data area that contains or will contain the file. Possible codes are D1, D2, D3 or D31, D32, D33, D34, D4 or D41, D42, D43, D44.
		PACK-name LABEL-filename	Name of area that contains or will contain the file. Name by which your file is identified or will be identified on disk.
	RECORDS or TRACKS LOCATION	RECORDS-number or TRACKS-number	Approximate number of records for the file. Number of tracks required by the file.
		LOCATION-track number	Track number on which file begins or is to begin (simulation area only).
		LOCATION-cylinder number	Cylinder number on which file begins or is to begin. Track assumed zero (main data area only).
		LOCATION-cylinder number/ track number	Cylinder number, track number on which file begins or is to begin (main data area only).
	RETAIN	RETAIN-T	Temporary file.
		S	Scratch file.
		P	Permanent file.
	DATE	DATE-mmddyy ddmmyy	Tells the system the date the file was created.
HIKEY	HIKEY 'highest unpacked key fields allowed'	List of highest unpacked key fields allowed on each pack of an indexed multivolume file (main data area only).	
	-or- HIKEY-P 'highest packed keyed fields allowed'	List of highest packed key fields allowed on each pack of an indexed multivolume file (main data area only).	
VERIFY	VERIFY-YES	Verify disk write operations for this file (main data area only).	
SHARE	NO	Do not verify disk write operations for this file.	
	SHARE-YES	Allow file sharing between partitions if access methods are compatible.	
	NO	Do not allow file sharing. Multiple references to the same file within one program are not allowed if SHARE-NO is specified. If parameter is omitted, SHARE-YES is assumed.	

Figure 46 (Part 2 of 7). Parameters for OCL Statements

Statement	Parameter	Code	Meaning of Code
// FILE (tape file)	NAME UNIT	NAME-filename	Name the program uses to refer to the file.
		UNIT-T1	Where the tape that contains or will contain the file is mounted.
		T2	
		T3	
	REEL	T4	
		REEL-nnnnnn	Name of the labeled tape that contains or will contain the file.
		NL	The tape is not labeled.
		NS	The tape contains non-standard labels (input only).
		BLP	A standard labeled tape is mounted. Bypass label processing (input only).
	LABEL	LABEL-name or LABEL- 'character string'	Name by which your file is identified on tape.
	DATE	DATE-mmddyy ddmmyy	The date the file was created.
	RETAIN	RETAIN-nnn	The number of days a file should be retained before it expires.
	BLKL RECL RECFM	BLKL-block length	The number of bytes in a physical block on tape.
		RECL-record length	The number of bytes in a logical record.
		RECFM-F	Fixed length, unblocked records.
		V	Variable length, unblocked records.
		D	Variable length, unblocked D-type ASCII records.
		FB	Fixed length, blocked records.
	END	VB	Variable length, blocked records.
		DB	Variable length, blocked, D-type ASCII records.
		END-LEAVE	The tape remains in position after the file is processed.
UNLOAD		The tape is rewound and unloaded after processing.	
REWIND		The tape is rewound after processing.	
DENSITY	DENSITY-200	The tape will be written at 200 bpi (bits per inch) density.	
	556	The tape will be written at 556 bpi density.	
	800	The tape will be written at 800 bpi density.	
	1600	The tape will be written at 1,600 bpi density.	
		Default for 7-track is 800 bpi.	
ASCII	ASCII-YES <u>NO</u>	An ASCII file is being processed or created.	
DEFER	DEFER-YES <u>NO</u>	An EBCDIC file is being processed or created.	
CONVERT	CONVERT-ON	The tape volume will be mounted later.	
	<u>OFF</u>	The tape is presently mounted.	
TRANSLATE		Data read from or written to a 7-track tape file will be converted.	
	<u>OFF</u>	Data read from or written to a 7-track tape file will not be converted.	
	TRANSLATE-ON	Data read from or written to a 7-track tape file will be translated.	
	<u>OFF</u>	Data read from or written to a 7-track tape file will not be translated.	

Figure 46 (Part 3 of 7). Parameters for OCL Statements

Statement	Parameter	Code	Meaning of Code
// FILE (tape) (continued)	PARITY	PARITY-EVEN  <u>ODD</u>	The 7-track tape file will be read or written in even parity. The 7-track tape file will be read or written in odd parity.
	SEQNUM	SEQNUM-nnnn X	File sequence number can be 0001 to 9999. Prepositioned file.
// FILE (device independent card, diskette, or printer files)	NAME	NAME-filename	Name the program uses to refer to the file.
	UNIT	UNIT-MFCU1 MFCU2 MFCM1 MFCM2 1442 2501 3741 1403 3284 READER PRINTER PUNCH	Primary hopper of 5424 MFCU. Secondary hopper of 5424 MFCU. Primary hopper of 2560 MFCM. Secondary hopper of 2560 MFCM. 1442 Card Read Punch. 2501 Card Reader. 3741 Data Station/Programmable Work Station. 1403 Printer. 3284 Printer. Use the partition's assigned system input device. Use the partition's assigned system print device. Use the partition's assigned system punch device.
	PRINT	PRINT- <u>YES</u> NO	Interpreting is to be done on punch files. Interpreting is not to be done on punch files.
	RECL	RECL-record length	Number of bytes in a logical record (3741 only).
// HALT	None		
// IMAGE	format	HEX  CHAR	Characters from system input device are in hexadecimal form. Characters from system input device are in EBCDIC form.
	number	MEM	Characters are from the source library.
	name	value	Number of new characters.
	unit	name	Identifies the source member containing the characters in the source library.
		5444 unit code	Specifies the simulation area that contains the source library. Possible codes are R1, F1, R2, F2.
// INCLUDE	procedure name	name	The name of the procedure that contains the OCL to be merged.
	unit	5444 unit code	Specifies the simulation area that contains the procedure. Possible codes are R1, F1, R2, F2.
	switch characters	xxxxxxxx	Specifies 8 switch characters that are compared with the eight external indicators. Possible characters are 0, 1, X.

Figure 46 (Part 4 of 7). Parameters for OCL Statements

Statement	Parameter	Code	Meaning of Code
//jobname JOB	PRIORITY  CORE  SPOOL  PARTITION   QCOPY	PRIORITY-0 <u>1</u> 2 3 4 5  CORE-size  SPOOL- <u>YES</u> NO PARTITION- <u>1</u> <u>2</u> 3 A B C D  QCOPY- <u>YES</u> NO	Specifies a job's priority on the reader queue and on the output queues unless overridden by a PRIORITY parameter on a PRINTER or PUNCH statement.  Specifies amount of main storage required to execute the largest step of a job. Indicates whether spooling can or cannot be used for the job. Default is YES. Specifies the partition in which a spooled job should be executed. A means 1 or 2; B means 1 or 3; C means 2 or 3; D means 1, 2, or 3.  Allows (QCOPY-YES) or disallows (QCOPY-NO) the spool file copy program (\$QCOPY) to access this job on the reader queue.
// LOAD or //stepname LOAD	asterisk program-name unit switch characters	* name main data area code xxxxxxx	Program is to be loaded from the system input device. Identifies the file that contains the object program. Specifies the main data area that contains the file. Specifies 8 switch characters that are compared with the eight external indicators. Possible characters are 0, 1, X.
// LOAD or //stepname LOAD	program-name  unit  switch characters	name  5444 unit code  xxxxxxx	Name of program that is to be loaded from an object library on disk. Specifies the simulation area that contains the program. Possible codes are R1, F1, R2, F2. Specifies 8 switch characters that are compared with the eight external indicators. Possible characters are 0, 1, X.
// LOG	device   mode	CONSOLE 1403  3284  <u>EJECT</u> <sup>1</sup> NOEJECT <sup>1</sup>	Log to CRT and system history area on system pack. Log to CRT, the 1403 printer, and the system history area on the system pack. Log to CRT, the 3284 printer, and the system history area on the system pack. Eject a page before ES and EJ and after EJ. Do not eject a page before ES and EJ and after EJ.
<sup>1</sup> When you use the spool print writer, an eject occurs at the start of every job step, regardless of the mode specified in the LOG statement.			

Figure 46 (Part 5 of 7). Parameters for OCL Statements

Statement	Parameter	Code	Meaning of Code
// NOHALT	SEVERITY	SEVERITY-1 2 4 8	Tells the system to select default options for error halts.
// PAUSE	None		
// PRINTER	DEVICE LINES FORMSNO COPIES DEFER CLOSE QCOPY ALIGN PRIORITY	DEVICE-1403 3284 LINES-number FORMSNO-forms type COPIES-number DEFER- <u>YES</u> NO CLOSE- <u>YES</u> NO QCOPY- <u>YES</u> NO ALIGN- <u>YES</u> NO PRIORITY-0 1 2 3 4 5	1403 Printer is used as the system print device. 3284 Printer is used as the system print device. Specifies the number of print lines per page. Informs the operator which forms type should be mounted on the printer, and determines the forms type of the spooled printed output. With spooling active, allows you to obtain more than one copy of each job step's printed output. Allows you to begin printing a job step's spooled output before the job step completes execution (DEFER-NO). Default is DEFER-YES. Allows you to control when print spool will close an intercepted job step on the spool file. Allows you to prevent spool file print records from being copied by the spool file copy program. Allows you to perform forms alignment for spooled printed output (ALIGN-YES). Default is ALIGN-NO. Specifies a job step's priority on the spool print queue. Default is the priority of the job at the time it is executed.
// PUNCH	DEVICE CARDNO COPIES DEFER QCOPY PRIORITY	DEVICE-MFCM1 MFCM2 MFCU1 MFCU2 1442 3741 CARDNO-card type COPIES-number DEFER- <u>YES</u> NO QCOPY- <u>YES</u> NO PRIORITY-0 1 2 3 4 5	Primary hopper of 2560 MFCM. Secondary hopper of 2560 MFCM. Primary hopper of 5424 MFCU. Secondary hopper of 5424 MFCU. 1442 Card Read Punch. 3741 Data Station/Programmable Work Station. Tells the operator which card type to use for punching. With spooling active, allows you to obtain more than one copy of each job step's punched output. Allows you to begin punching a job step's spooled output before the job step completes execution (DEFER-NO). Default is DEFER-YES. Allows you to prevent spool file punch records from being copied by the spool file copy program. Specifies a job step's priority on the spool punch queue. Default is the priority of the job at the time it is executed.

Figure 46 (Part 6 of 7). Parameters for OCL Statements



Statement	Parameter	Code	Meaning of Code
// READER	code	CONSOLE MFCU1 MFCU2 MFCM1 MFCM2 1442 2501 3741	CRT/keyboard. Primary hopper of 5424 MFCU. Secondary hopper of 5424 MFCU. Primary hopper of 2560 MFCM. Secondary hopper of 2560 MFCM. 1442 Card Read Punch. 2501 Card Reader. 3741 Data Station/Programmable Work Station.
// RUN	None		
// SWITCH	indicator- settings	0 1 X	Set external indicator off. Set external indicator on. Leave external indicator as it is.
/&	None		
/.	None		
* (Comment)	None		
* TIME			Write a time stamp to the SHA (system history area).

Figure 46 (Part 7 of 7). Parameters for OCL Statements



- Executing an Inquiry Program
- Interrupting an Object Program
- RPG II Telecommunications Program

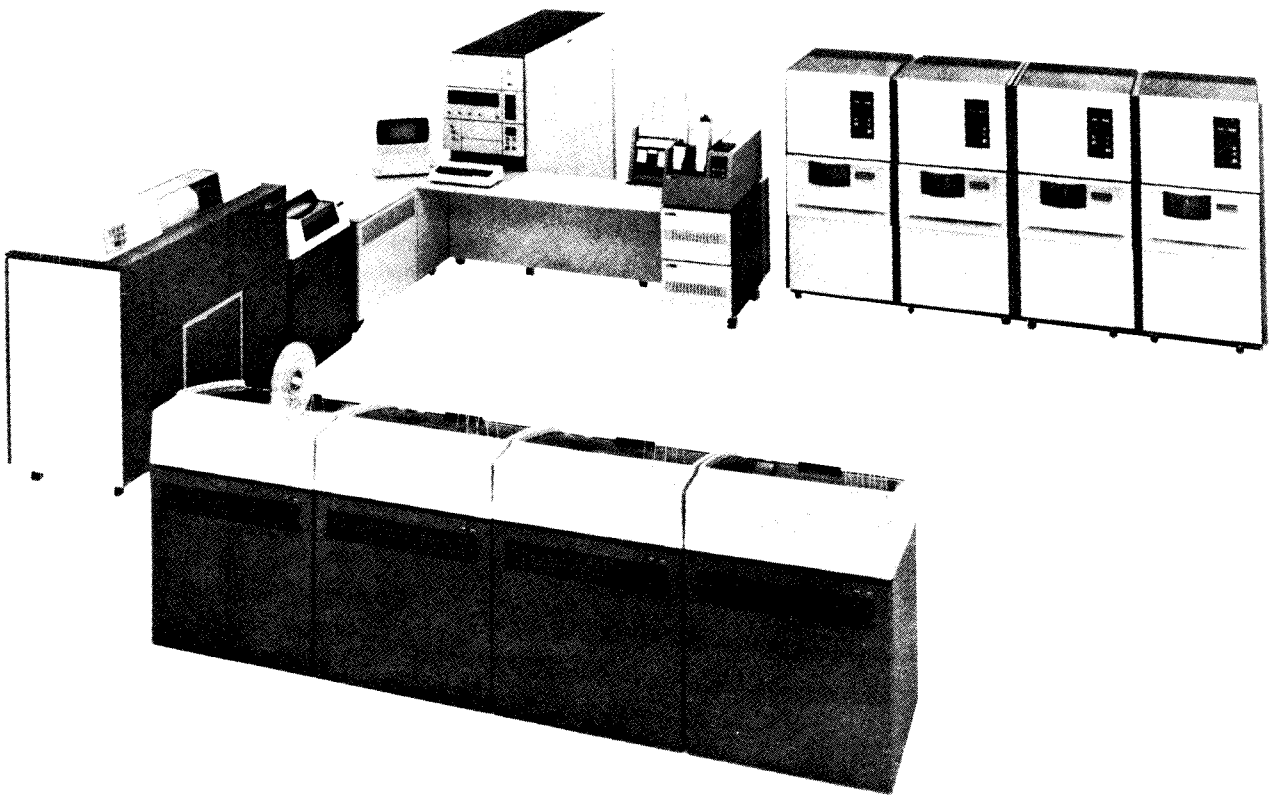

During object program execution, a number of messages can occur; some are system messages and others are program messages (messages produced by the program). If responses are required to program messages, they are explained on the program run sheet. System messages are explained in *IBM System/3 Model 15 System Messages*, GC21-5076.

## EXECUTING AN INQUIRY PROGRAM

An inquiry program is an RPG II or FORTRAN program with a CRT/keyboard input file that is identified as an I-type program. I-type programs can be executed only by an inquiry request (pressing the PA1 key on the keyboard). An I-type program cannot be interrupted. I-type programs are most efficient in a multiprogramming environment but can also be used on a dedicated system.

### Executing an I-type Program That Uses the CRT/Keyboard for Input

1. Mount the disk cartridge as specified on the program run sheet and ready the disk drives.
2. Key OCL statements via the keyboard. When the program is loaded, WAITING FOR REQUEST  $\left\{ \begin{matrix} P1 \\ P2 \\ P3 \end{matrix} \right\}$  is displayed on the CRT screen.

*Note:* The OCL statements can be on cards. If so, it should be indicated on the program run sheet.

Place the OCL statements in the hopper, start the reader, and start the partition.

3. When you are ready to enter a record, press the PA1 key. ENTER DATA  $\left\{ \begin{matrix} P1 \\ P2 \\ P3 \end{matrix} \right\}$  is displayed.
4. Key the data record. The data record is processed, then the prompt WAITING FOR REQUEST  $\left\{ \begin{matrix} P1 \\ P2 \\ P3 \end{matrix} \right\}$  is displayed.
5. Repeat steps 3 and 4 for each record.
6. When no more records are to be processed, press the PA1 key and key in /\*. The end-of-job message is then displayed. If other halts occur, see *IBM System/3 Model 15 System Messages*, GC21-5076.

## INTERRUPTING AN OBJECT PROGRAM (ROLLOUT/ROLLIN) (5704-SC1 ONLY)

Some programs can be interrupted during execution. For a description of programs that can be interrupted by rollout, see *IBM System/3 Model 15 System Control Programming Reference Manual*, GC21-5077. When the interrupt is initiated, the program in storage is placed on disk (rolled out). A new job can then be loaded into storage and executed.

Perform the following procedures to interrupt an object program:

1. Enter the ROLLOUT command. The job in storage is now placed out on disk by the system.
2. When the JY message is displayed, check the program run sheet to see if the interrupted program is using a card reader. Perform the following steps as required. If the MFCU, MFCM, or 3741 is not being used, proceed to step 6. If the interrupted program is using tapes, do not rewind or dismount the tapes. These tape units are not available for use by the new program being loaded.

*Note:* If the card reader is not needed by the new job, do not run cards out of the machines. When the J' message occurs, select the option to bypass card repositioning.

If the 3741 is the input device for the interrupted program and will be used by the new program being loaded, record the current diskette address (tt0ss) displayed on the 3741 status line. Save this address for use when the program is rolled in. Take the 3741 offline. For online/offline operation, refer to *IBM System/3 3741 Reference Manual*, GC21-5113.

If the 3741 is the output device for the interrupted program and will be needed by the new program, press FUNCT SEL (upper), press T, and take the 3741 offline. If the 3741 is not used by the interrupting program, it can be kept online.

3. Remove cards from the stackers and set them aside.
4. Remove cards from the hoppers. Note which hoppers these cards came from because you will have to use them later.

5. Press NPRO on MFCU or MFCM. Place cards from the primary hopper fed into stacker 1 in front of cards removed from primary hopper. Place cards fed into stacker 5 (4 if MFCM Model A2) in front of any cards removed from secondary hopper. This ends the procedure on the MFCU or MFCM.
6. Check the program run sheet to see if the interrupted program is using the 1442 or the 2501. If not, proceed to step 10.
7. Remove cards from the 1442 or 2501 stackers and set them aside. They are not used again by this job.
8. Remove cards from the hopper. You have to use these cards later.
9. Press NPRO on 1442 or 2501. Place cards fed into the stackers in front of cards removed from the hopper.
10. Place cards for new job in hoppers or insert the proper diskette as indicated on the program run sheet.
11. Start the card reader. Put the 3741 online.
12. Mount disk cartridge and tape reels as specified on the program run sheet for the new program, and ready the disks and tape units. If the IPL process was performed from a removable disk, that disk must not be removed.

*Note:* If the other partition is active and is using one of the disk or tape units required by the new program, do not remove the disk cartridge, data module, or tape reel until the other partition has finished.<sup>1</sup>

13. Ready the printer.
14. Respond to the JY message with option 0 to allow the job to execute, or with option 2 to cancel the rollout request. If you reply with option 2, proceed to step 19.

15. When the prompt ENTER READER DATA P1 is displayed, enter the OCL statements for the interrupting program via the keyboard. If the OCL is to be read from a card reader or the 3741, you need enter only the READER OCL statement.

*Note:* Only one OCL sequence (LOAD/RUN or CALL/RUN) may be entered from the system input device following a rollout request. More than one program may be executed during a rollout request only when a nested procedure is used.

16. The job begins execution. When the job is complete, J' message is displayed. You must now restore the conditions that existed before the previous job was interrupted. If the 3741 is taken offline, the following steps restore it for use by the program being rolled in:
  - a. Insert the correct diskette in drive 1.
  - b. Select the correct data set.
  - c. If the 3741 is an input device for the interrupted program, use the record address (ttOss that you recorded in step 2) for *Searching for a Record by its Address* (refer to *IBM 3741 Data Station Operator's Guide*, GA21-9131).
  - d. Select the mode and put the 3741 online.
  - e. If the 3741 is an output device for the interrupted program, find the last record in the data set by *Searching End of Data* (refer to *IBM 3741 Data Station Operator's Guide*, GA21-9131).

If a card reader was used by the interrupting job, you must prepare any card devices used by the interrupted program for card repositioning. If a card device was not used and the cards were left in the machines, proceed to step 20.

17. Clear cards from the card reader.
18. Remove cards from the stacker.
19. If any cards for the interrupted program were removed from the reader, replace them in the appropriate hoppers.
20. Start the card reader.
21. Remount the disk cartridge used by the interrupted job and ready the disk drives.

*Note:* Again make sure the other partition is not using the disk unit before remounting the disk cartridge or data module.

<sup>1</sup> Respond to the JY message with option 2 and retry the rollout after the other partition has gone to end of job.

22. Ready the printer.
23. Respond to the J' message with option 0 to continue processing the interrupted program and to indicate that card repositioning is necessary. Respond with option 1 to continue the program if card repositioning is not necessary. Respond with option 2 to cancel the interrupted program.

### Using Rollout with Spooling (5704-SC1 Only)

Rollout can be used on a system that supports spooling. However, if devices needed by the interrupting program are being used by spooling, these spooled devices will have to be stopped via the STOP command to make the device available.

To use rollout when spooling, follow this procedure:

1. Enter the ROLLOUT command. The job executing in partition 1 is placed on disk.
2. When the JY message is displayed, respond with option 0 to continue the rollout operation or with option 2 to cancel the rollout request.
3. Check the program run sheet to see whether the interrupting program requires any of the spooled devices. If so, enter the STOP command for each device needed. The prompt ENTER READER DATA P1 is displayed.
4. Enter the OCL for the interrupting job from the keyboard. If the OCL is on cards, enter just the READER OCL statement.

**Note:** The job stream for the interrupting job must not contain a JOB OCL statement or two consecutive /. OCL statements.

5. The interrupting program is executed. The program's output is not spooled. At the completion of the job, the interrupted program is rolled back into main storage. The message J' is displayed.
6. Respond to the J' message with option 0 to continue processing the interrupted job. Respond with option 2 to cancel the interrupted job.
7. Enter the START commands necessary to start the spooled devices that were being used. If the spooled printer was stopped, the RESTART command can be entered.

## RPG II TELECOMMUNICATIONS PROGRAM

This section gives the requirements for executing an RPG II program that contains specifications for telecommunications. Any messages that occur are listed in the *IBM System/3 Model 15 System Messages*, GC21-5076.

A schedule must be established to ensure that each BSCA station loads its program at the correct time. On a leased network, the receiving station must start first; on a multi-point network, the System/3 terminal must start first. These programs will wait; a transmit program will not wait for the receiving program to be started. On a switched network, the answering terminal must be ready first.

### Nonswitched Networks

1. Mount the disk cartridges and tape reels specified on the program run sheet and ready the disk and tape units.
2. Clear cards from the card reader.
3. Remove cards from stackers.
4. Place OCL statements, object deck (if any), and data cards (if any) in hoppers as specified on program run sheet.
5. Start the card reader.
6. Ready the printer.
7. Start the partition. The programs are loaded and transfer of data occurs. Transmission is complete when the end-of-job message is displayed.

## Switched Networks

The procedures you use when your system is on a switched network depend on whether you are initiating the call and whether the initiation of the call is being made manually or automatically.

### *Initiating a Call Manually*

1. Mount the disk cartridges and tape reels specified on the program run sheet and ready the disk and tape units.
2. Clear cards from the card reader.
3. Remove cards from the stacker.
4. Place OCL statements, object deck (if any), and data cards (if any) in hoppers as specified on program run sheet.
5. Press START on the card reader.
6. Ready printer.
7. Initiate the appropriate partition. The program is loaded and execution begins.
8. When message Y7 occurs, do the following:
  - a. Press TALK on DATA-PHONE.
  - b. Respond to the Y7 message with a 0 option.
  - c. Wait for I/O ATTENTION and BSCA ATTN lights to turn on.
  - d. Pick up receiver and dial digits in proper sequence.
  - e. Talk with the operator on the other system; or, if AUTO is pressed on the DATA-PHONE of the other system, wait for a high-pitched tone.
  - f. Press DATA on the DATA-PHONE.
  - g. Place receiver back on phone.
9. Transmission is complete when end-of-job message is displayed.

### *Initiating a Call Automatically*

1. Mount the disk cartridges and tape reels specified on the program run sheet and ready the disk and tape units.
2. Press AUTO on DATA-PHONE.
3. Clear cards from the card reader.
4. Remove cards from stackers.

5. Place OCL statements, object deck (if any), and data cards (if any) in the hoppers specified on the program run sheet.
6. Start the card reader.
7. Ready the printer.
8. Start the partition. When the operator or the other system answers, data is transmitted. Transmission is complete when the end-of-job message is displayed.

### *Answering a Call Manually*

1. Mount the disk cartridges and tape reels as specified on the program run sheet and ready the disk and tape units.
2. Clear cards from the card reader.
3. Remove cards from stackers.
4. Place OCL statements, object deck (if any), and data cards (if any) in the hoppers specified on the program run sheet.
5. Start the card reader.
6. Ready the printer.
7. Start the partition. The program is loaded and execution begins.
8. When the Y8 message occurs, do the following:
  - a. Press TALK on DATA-PHONE and wait for incoming call.
  - b. Respond to the Y8 message with a 0 option.
  - c. Wait for RECEIVE INITIAL light on BSCA panel to turn on.
  - d. Lift receiver and talk with the operator of the other system, or wait for a high-pitched tone if AUTO CALL is used by the calling station.
  - e. Press DATA on your DATA-PHONE.
  - f. Place receiver back on phone. Data is transmitted.
9. Transmission is complete when the end-of-job message is displayed on the CRT screen.

### Answering a Call Automatically

1. Mount the disk cartridges and tape reels as specified on the program run sheet and ready the disk and tape units.
2. Press AUTO on the DATA-PHONE.
3. Clear cards from the card reader.
4. Remove cards from stackers.
5. Place OCL statements, object deck (if any), and data cards (if any) in the hoppers specified on the program run sheet.
6. Start the card reader.
7. Ready the printer.
8. Start the partition. When the connection is made, data is transmitted. Transmission is complete when the end-of-job message is displayed on the CRT screen.

### Device Counter Logout Program

The primary purpose of the Device Counter Logout program is to report information about errors that were recorded during execution of a binary synchronous communications (BSC) program that contained the programming support to update these counters. You should run the Device Counter Logout program immediately after every such BSC program.

The Device Counter Logout program prints the counters for adapter 1 (and adapter 2 if available on the system). The contents of the terminal statistics table, MLTERFIL, which is a permanent file on F1 and contains counters for multipoint control stations only, is printed following the counters. If MLTERFIL does not contain any entries for an adapter, the following message is printed in place of the contents of MLTERFIL:

TERMINAL STATISTICS TABLE (MLTERFIL) EMPTY

If MLTERFIL does not exist, the following message is printed:

TERMINAL STATISTICS TABLE (MLTERFIL) NOT FOUND

Adapter 2 information is printed on a separate page.

The contents of the counters will be displayed on the device assigned as the system LOG.

### Operating Procedure

1. Place the following OCL cards in the card reader:

```
// LOG { 1403 }  
      { 3284 }  
      { CONSOLE }
```

```
// LOAD $$BSDL,F1 (Use R1 if your system pack  
is mounted there.)
```

```
// RUN
```

2. Start the card reader.
3. Ready the system LOG device.
4. Start the partition. The device counters will be printed in the following format:



BSCA LOG mm/dd/yy

ADAPTER 1

COUNTER DESCRIPTION	TOTAL	LAST JOB
TEXT BLOCKS SENT	nnnn	nnnn
TEXT BLOCKS RECEIVED	nnnn	nnnn
NAKS RECEIVED	nnnn	nnnn
DATA CHECKS	nnnn	nnnn
FORWARD ABORTS	nnnn	nnnn
ABORTS	nnnn	nnnn
ADAPTER CHECKS ON TRANSMIT	nnnn	nnnn
ADAPTER CHECKS ON RECEIVE	nnnn	nnnn
INVALID REPLIES	nnnn	nnnn
ENQS RECEIVED	nnnn	nnnn
LOST DATA COUNT	nnnn	nnnn
DISCONNECT TIMEOUTS	nnnn	nnnn
TIMEOUTS DURING RECEIVE DATA	nnnn	nnnn

TERMINAL ADDRESS	UNSUCCESSFUL I/O OPERATIONS	SUCCESSFUL I/O OPERATIONS
Address 1	nnnn	nnnn
Address 2	nnnn	nnnn
Address 3	nnnn	nnnn
Address 4	nnnn	nnnn
Address 5	nnnn	nnnn
Address 6	nnnn	nnnn
Address 7	nnnn	nnnn
Address 8	nnnn	nnnn
Address 9	nnnn	nnnn
Address 10	nnnn	nnnn

ADAPTER 2

COUNTER DESCRIPTION	TOTAL	LAST JOB
TEXT BLOCKS SENT	nnnn	nnnn
TEXT BLOCKS RECEIVED	nnnn	nnnn
NAKS RECEIVED	nnnn	nnnn
DATA CHECKS	nnnn	nnnn
FORWARD ABORTS	nnnn	nnnn
ABORTS	nnnn	nnnn
ADAPTER CHECKS ON TRANSMIT	nnnn	nnnn
ADAPTER CHECKS ON RECEIVE	nnnn	nnnn
INVALID REPLIES	nnnn	nnnn
ENQS RECEIVED	nnnn	nnnn
LOST DATA COUNT	nnnn	nnnn
DISCONNECT TIMEOUTS	nnnn	nnnn
TIMEOUTS DURING RECEIVE DATA	nnnn	nnnn

TERMINAL ADDRESS	UNSUCCESSFUL I/O OPERATIONS	SUCCESSFUL I/O OPERATIONS
Address 1	nnnn	nnnn

The entries have the following meaning:

- BSCA LOG      Heading to identify the printout.
- mm/dd/yy      Date stored in the system communication area.

- ADAPTER      Identifies adapter being used.
- TEXT BLOCKS SENT      Number of blocks of data transmitted successfully from this terminal to a remote terminal.
- TEXT BLOCKS RECEIVED      Number of blocks of data received successfully by this terminal from a remote terminal.
- NAKS RECEIVED      Number of negative responses received by this terminal in response to data transmitted by this terminal.
- DATA CHECKS      Number of text blocks received with invalid error check bits.
- FORWARD ABORTS      Number of times a remote terminal has terminated transmission abnormally while transmitting data.
- ABORTS      Number of times a remote terminal has terminated transmission abnormally while receiving data.
- ADAPTER CHECKS ON TRANSMIT      Number of times the following errors occurred while the terminal was transmitting data:
  1. Parity check within the adapter.
  2. Cycle steal overrun.
  3. Local storage register or control register check.
- ADAPTER CHECKS ON RECEIVE      Number of times the following errors occurred while the terminal was receiving data:
  1. Parity check within the adapter.
  2. Cycle steal overrun.
  3. Local storage register or control register check.
- INVALID REPLIES      Number of abnormal responses (including no responses) from the remote terminal.
- ENQ'S RECEIVED      Number of requests for retransmission of this terminal's last acknowledgement after the acknowledgement has already been sent.
- LOST DATA COUNT      Number of text blocks received which do not fit into the receive area.
- DISCONNECT TIMEOUTS      Number of times the data set has dropped ready status after that status was set on.
- TIMEOUTS DURING RECEIVE DATA      Number of times this terminal expected to receive text but did not receive anything for 3.25 seconds.



## Chapter 20. Running System Service Programs and Utility Programs

- System Service Programs
- Disk Sort Program
- Tape Sort Program
- Disk Resident Card Utility Programs

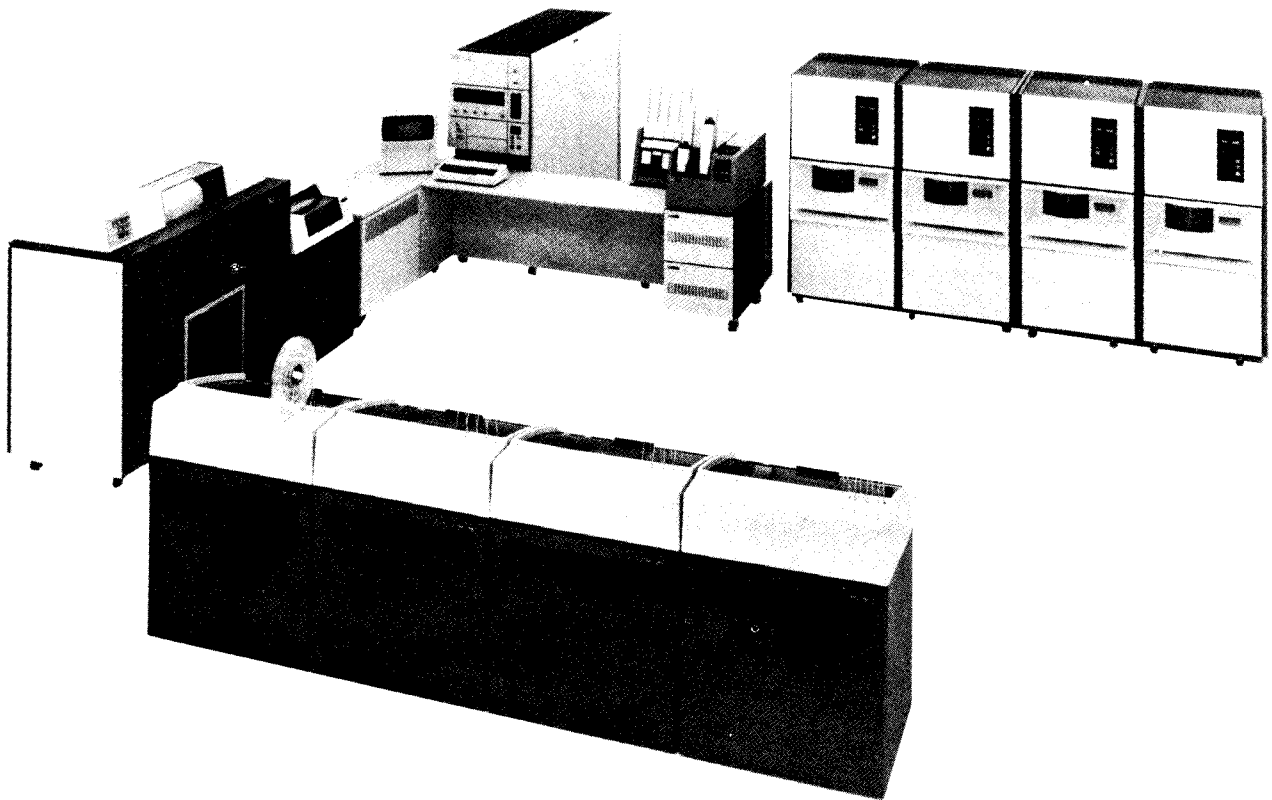

## SYSTEM SERVICE PROGRAMS

The system service programs provided with your system perform a variety of jobs, such as preparing disks for use or adding a new or changed program to the system. This section provides procedures for running the following system service programs:

- **\$ALT (Alternate Track Assignment)**—assigns alternate tracks to disk tracks that become defective after they are initialized. The data on the defective track is transferred to the alternate track.
- **\$BUILD (Alternate Track Rebuild)**—corrects data that could not be transferred to an alternate track or was transferred in error.
- **\$CNFIG (Configuration Record Program—5704-SC2 only)**—changes the assignment of 5444 unit codes to simulation areas that were made during system generation or during a previous execution of this program. This program also changes the catalog option that was made during system generation or during a previous execution of this program. New configuration record program assignments become effective when the next IPL is performed.
- **\$COPY (Copy/Dump)**—copies the contents of one disk to another disk, copies a data file from one location (disk, diskette, tape, or cards) to another location (disk, diskette, tape, cards, or printer), and prints all or part of a data file. **\$COPY** allows the recovery of data by physical address (the new data file can have a different record length than the old data file). It also allows the user to create direct output files from sequential input files (files may have different record lengths) and to create new files from old files (the new files can have a new record length).
- **\$DCOPY (Dump/Restore)**—copies the contents from a disk to tape or the contents of a tape to disk. This program also allows the user to copy a 5444 disk or a simulation area to a diskette or to copy a diskette to a 5444 disk or simulation area.
- **\$DELETE (File Delete)**—deletes files from a disk and the file references from the VTOC, deletes only the file reference in the VTOC from a disk without deleting the data, or frees space that has been allocated on a disk but does not actually contain data.
- **\$FCOMP (File Compress)**—copies all the files from one main data area to another main data area; or moves all the files to a low-order or high-order address on the same main data area.
- **\$HACCP (System History Area Copy—5704-SC2 only)**—under control of CCP, copies the system history area to a main data area disk file.
- **\$HIST (System History Area Display)**—prints the contents of the system history area or copies the contents of the system history area to a file on a device supported by device independent data management.
- **\$INIT (Disk Initialization)**—prepares a disk for use. This program must be run before a new disk is used for the first time or when the contents of a disk can be erased.
- **\$KLEAN (Chain Cleaning Program)**—allows the user to clean an IBM 1403 Printer chain or train.
- **\$LABEL (File and Volume Label Display)**—prints the contents of an area on disk called the volume table of contents (VTOC). This area contains information on all data files and libraries on disk.
- **\$MAINT (Library Maintenance)**—builds, maintains, and services disk-resident source and object libraries.
- **\$QCOPY (Spool File Copy)**—accesses the spool queues from a program partition—either batch or CCP. The user can copy **\$SPOOL** file to disk or tape; copy jobs into the reader queue from a file, terminal, or system input device; copy print or punch steps to a file; copy reader queue job streams to a file; copy selected jobs or job steps from one spool file to another; restore print or punch steps from a file to the print or punch device or to the spool queues; copy the spool queue status display to a file or terminal; assign class numbers to programs; maintain the **\$QCOPY** authorization file.

- **\$RINDX** (Recover Index Program)—allows the user to recover records that were added to a file after the program was abnormally terminated. Recovery is performed only on indexed files.
- **\$RSALT** (Reassign Alternate Track)—reassigns alternate tracks on a 3340 data module. The data module can then be used by a System/360 or a System/370. This program enables a 3340 data module initialized in System/3 format to be initialized by System/360 or System/370 direct access storage device initialization programs.
- **\$SCOPY** (Simulation Area Program)—copies a 5444 simulation area on a 3340/3344 data module to another area on the same or different data module.
- **\$TINIT** (Tape Initialization)—prepares tapes for use. Checks labeled tapes for a volume label and unexpired files, writes IBM standard volume labels on the tapes, and displays the volume and header labels.

*Note:* User labels are not checked by System/3 tape data management and cannot be written as part of the label group.

**This page is intentionally left blank.**

- **\$TVES (Tape Error Summary)**—prints a summary by tape volume and tape unit of certain tape errors. Counters of these errors are recorded on the tracks reserved for the IBM Customer Engineer on disk unit F1.
- **\$VTOC (5445 Data Interchange)**—reformats the volume table of contents on a 2316 disk cartridge so it can be used with a System/360 or System/370. The 5445 Data Interchange program must be run before a disk pack is used on System/360 or System/370 and must be run again before the disk is used again on the System/3.
- **\$WVTOC (1000-File VTOC Conversion)**—expands file capacity by converting a 50-file VTOC to a 5445 1000-file VTOC retaining active files and moving the labels of these files to the beginning of the VTOC for improved performance in file access time. This program also converts a 5445 1000-file VTOC to a 50-file VTOC capacity.

Each system service program to be run has OCL statements followed by control statements. The OCL statements consist of a LOAD statement, in some cases one or more FILE statements, and a RUN statement. The LOAD statement has the name of the system service program to be run. The FILE statement provides the system with information about files. The RUN statement tells the system service program to begin.

Control statements follow the OCL statements. These control statements are read by the system service program. They tell the program what to do. The last statement of the control statements is END, which tells the program that there are no more control statements.

For more information on the system service programs and their OCL and control statements, see the *IBM System/3 Model 15 System Control Programming Reference Manual*, GC21-5077 (5704-SC1), or the *IBM System/3 Model 15 System Control Programming Concepts and Reference Manual*, GC21-5162 (5704-SC2).

### Operating Procedures

Operating procedures for the system service programs are the same, except for the copy/dump and library maintenance programs. Procedures for copy/dump, dump/restore, and library maintenance are discussed later in this section.

### *Operating Procedures for System Service Programs Except Copy/Dump, Dump/Restore, and Library Maintenance*

1. Mount the disk cartridge or data module, if one is specified on the program run sheet, and ready the disk device.
2. Mount the tape reels as specified on the program run sheet and ready the tape units.
3. Clear cards from the reader if used.
4. Place OCL statements and control statements in reader if the reader is used.
5. Start the card reader if used.
6. Ready the printer.
7. Start the partition. The program performs the functions indicated on the control statements. An end-of-job message appears on the CRT screen when the program is completed. See the *IBM System/3 Model 15 System Messages*, GC21-5076, for other programmed messages and how to respond to them.

### *Operating Procedures for Copy/Dump Program*

Operating procedures for copy/dump are the same as for the other system services programs except when you have to mount several different cartridges on the same drive during the running of the program. The program run sheet indicates when this type of copy/dump program is being run.

1. Mount the disk cartridges or data module and tape reels and load the data cards into the card reader as specified on the program run sheet and ready the I/O devices.
2. Clear cards from the reader if used.
3. Place OCL statements and control statements in the reader if the reader is used.
4. Start the card reader if used.
5. Ready the printer.
6. Start the partition.

If the program is going to copy a pack from one removable disk on R1 to another removable disk on R1, you will be required to mount different cartridges at different times. Program messages indicate when to do this.

If the preceding steps 1 through 6 have been performed and you have mounted the proper cartridge on R1, continue with the procedure as follows:

1. After the program has copied data to the fixed disk or 5445 work file, a message of UC37TP occurs. At this time you must mount the cartridge the program is going to copy the data to. Keep the cartridge you removed handy, you may have to mount it again in step 3.
2. Start the partition by taking the 0 option to the message. If you mounted the wrong cartridge, a message of UC38WP occurs. To correct this, mount the correct cartridge, and restart the partition by taking the 1 option to the message.
3. When the data has been copied, another program message of UP37FP occurs. At this time you must remount the cartridge you removed in step 1.
4. Start the partition by taking the 0 option to the message.
5. Perform steps 1 through 3 as many times as necessary to get all the data copied onto the removable cartridge.
6. When the program is completed, the end-of-job message is displayed on the CRT screen.

### *Operating Procedures for Dump/Restore Program*

The dump/restore program copies (dumps) the entire contents of a disk onto tape and copies (restores) the information from the tape back to the same or a comparable disk.

#### *Copying a Disk to Tape (Dump)*

1. Mount and make ready the disk cartridge or data module if specified on the program run sheet.
2. Clear cards from reader if used.
3. Mount tape to be copied to.
4. Place OCL statements and control statements in the reader if the reader is used.
5. Start the card reader or put the 3741 online, positioned to the proper data set.
6. Ready the printer.
7. Start the partition. A dump/restore program can be executed in either partition (a dedicated system is not required).

After a successful copy, the copy program prints a message:

COPYPACK IS COMPLETE.

If an end-of-job message is not printed, the tape may be unusable.



*Tape Considerations*

The following table indicates the partitions and tape lengths required for the various combinations indicated:

Disk Unit	BLKL	CPU Partition	7-Track			9-Track	
			200	556	800	800	1600
5444 (Full capacity)	3072	8K	1416' (431.6m)	541' (164.9m)	391' (119.18m)	296' (90.22m)	168' (51.21m)
	6144	8K	1390' (423.67m)	516' (157.28m)	366' (111.56m)	276' (84.12m)	148' (45.11m)
	12288	14K	1378' (420.01m)	503' (153.31m)	354' (107.9m)	266' (81.08m)	138' (42.06m)
5445	2560	8K	11879 <sup>1</sup> (3620.72m)	4593 <sup>1</sup> (1399.95m)	3345 <sup>1</sup> (1019.56m)	2534 <sup>1</sup> (772.36m)	1467' (447.14m)
	5120	8K	11629 <sup>1</sup> (3544.52m)	4343 <sup>1</sup> (1323.75m)	3095 <sup>1</sup> (943.36m)	2334' (711.4m)	1267' (386.18m)
	10240	12K	11504 <sup>1</sup> (3506.42m)	4218 <sup>1</sup> (1285.65m)	2970 <sup>1</sup> (905.26m)	2234' (680.92m)	1167' (355.7m)
3340 (Main data area)	3072	8K	23647 <sup>1</sup> (7207.61m)	9035 <sup>1</sup> (2753.87m)	6530 <sup>1</sup> (1990.34m)	4944 <sup>1</sup> (1506.93m)	2806 <sup>1</sup> (855.27m)
	6144	8K	22521 <sup>1</sup> (6864.4m)	8359 <sup>1</sup> (2547.82m)	5929 <sup>1</sup> (1807.16m)	4609 <sup>1</sup> (1404.82m)	2471 <sup>1</sup> (753.16m)
	12288	14K	22118 <sup>1</sup> (6741.57m)	8020 <sup>1</sup> (2444.5m)	5811 <sup>1</sup> (1771.19m)	4442 <sup>1</sup> (1353.92m)	2304' (702.26m)
	24576	28K	21972 <sup>1</sup> (6697.07m)	7832 <sup>1</sup> (2387.19m)	5752 <sup>1</sup> (1753.21m)	4359 <sup>1</sup> (1328.62m)	2221' (676.96m)
3344 (Main data area)	3072	8K	26484' (8072.33m)	10119' (3084.28m)	6621' (2018.09m)	5537' (1687.68m)	3143' (957.99m)
	6144	8K	25223' (7687.98m)	9362' (2853.54m)	6306' (1922.07m)	5162' (1573.38m)	2767' (843.39m)
	12288	14K	24772' (7550.51m)	8982' (2737.72m)	6193' (1887.63m)	4975' (1516.38m)	2587' (788.52m)
	24576	28K	24608' (7500.52m)	8771' (2673.41m)	6152' (1875.13m)	4882' (1488.04m)	2487' (758.04m)

<sup>1</sup> Does not fit on a 2400' (731.52m) reel of tape.

More than one tape may be required to copy one disk. When this is the case, a new tape must be mounted. For proper procedure, see *Mounting a Reel* in Chapter 10 of this manual.

#### *Copying a Tape to Disk (Restore)*

1. Mount the tape to be copied from.
2. Mount and make ready the disk cartridge or data module if specified on the program run sheet.
3. Clear cards from reader if used.
4. Place OCL statements and control statements in the reader if used.
5. Start the card reader or put the 3741 online, positioned to the proper data set.
6. Ready the printer.
7. Start the partition.

When using the \$DCOPY program, the contents of the disk being copied to tape and the contents of the disk which later is copied from tape will be the same except for the disk names and alternate track information which may be different. The volume table of contents (VTOC) will be the same. The volume label will be the same except for pack name and volume identification (ID). Error statistics that are normally on cylinder 0 will not be transferred, nor will information in cylinder 0 be destroyed when restoring a pack. Initial program load (IPL) records will be copied if present.

If a permanent error occurs, the following message is printed at the time of error:

```
n TRACKS NOT RESTORED AT { CCC/SS }  
                           { CCC/HH/RR }
```

At completion of the job, the following message is printed if tape errors have occurred:

```
nn TAPE ERRORS OCCURRED. PACK IS NOT  
COMPLETELY RESTORED.
```

The copy program prints the following message whether it was a successful copy or a copy with error messages.

```
COPYPACK IS COMPLETE
```

If an end-of-job message is not printed, the disk may be unusable.

### *Operating Procedures for Library Maintenance Program*

1. Mount the disk cartridge or data module as specified on the program run sheet and ready the disks.
2. Clear the cards from the card reader if used.
3. Place OCL statements, control statements, and data statements (if any) in the reader if used.
4. Place blank cards in the hopper of the system punch device if the job is not spooled and if specified on the program run sheet, or put the 3741 online, positioned to the proper data set.
5. Start the reader.
6. Ready the printer.
7. Start the partition.
8. End-of-job message is displayed when the job is completed.
9. Remove any cards punched from the stacker.

If program halts occur while the program is running, see *IBM System/3 Model 15 System Messages, GC21-5076*, for recovery procedures.

#### **DISK SORT PROGRAM**

1. Mount disk cartridges or data modules and tape reels as specified on the program run sheet. Ready disks and tape units.
2. Ready the printer.
3. Start the partition. Various program messages can occur while the disk sort program is running. See the *IBM System/3 Model 15 System Messages, GC21-5076*, for the action you are to take.

4. Enter the required OCL statements and sort sequence specifications through the system input device. (If the sort specifications are in a procedure on disk, only the OCL statements are required to run the job.) When the sort specifications are on cards, enter them in this order:
  - a. OCL statements
  - b. Header specification
  - c. Optional alternate collating sequence specifications
  - d. Separator card
  - e. Record type and field specification cards
  - f. End-of-file card

When the job is complete, the end-of-job message is displayed on the CRT screen.

#### **TAPE SORT PROGRAM**

1. Mount the disk cartridges or data modules and tape reels as specified on the program run sheet. Ready the disk and tape units.
2. Ready the printer.
3. Start the partition. Various program messages can occur while the tape sort program is running. See *IBM System/3 Model 15 System Messages, GC21-5076*, for the action you are to take.
4. Enter the required OCL statements and sort sequence specifications by means of the system input device. The OCL, the sort sequence specifications, or both, may be copied from the source library on disk. If both are entered on cards, the proper sequence is:
  - a. OCL statements
  - b. Header specification
  - c. Optional alternate collating sequence specifications
  - d. Separator card
  - e. Record type specifications
  - f. Field specifications
  - g. End of file or END statement

When the job is complete, the end-of-job message is displayed.

## DISK RESIDENT CARD UTILITY PROGRAMS

This section describes the operating procedures for the following card utility programs:

- Sort/Collate
- List
- Reproduce/Interpret
- Gangpunch

### Sort/Collate Program

This program can be executed only with the MFCU or the MFCM, and must be run in a system where spooling is not activated. The following steps are required for all sort/collate jobs:

1. Mount the disk cartridge, if specified on the program run sheet, and ready the disk drive.
2. Clear cards from system input device.
3. Place OCL and specification cards in the system input device. The order of the cards is:
  - a. OCL cards
  - b. Header card
  - c. Optional alternate collating cards
  - d. Separator cards (if alternating collating cards are used)
  - e. Sort/collate specifications
  - f. End-of-job card (/\*)
4. Start the card device.
5. Ready the printer, if printing is specified.
6. Start the partition to load the program. When the program is loaded, it reads the specification cards and lists them on the system printer, if printing is specified.

The partition halts with one of the following messages displayed:

- EE (ready to go). This message signifies that the program is successfully loaded. Read the operating procedure for the job you are doing for further instructions.
- EL (condition message). Check the message on the system printer (if used) to determine cause (all sort/collate messages are described in *IBM System/3 Sort/Collate and Card Utilities Reference Manual*, SC21-7529. Read the operating procedure for the job you are doing for further instructions.
- EA (terminal message). This message indicates that something is wrong with the specification deck. The job must be canceled. To determine the cause of the error, check the message on the system printer (if used). The sort/collate program must be reloaded after the error is corrected. If the message display unit contains a message other than EE, EL, or EA, check the list of program messages in the *IBM System/3 Model 15 System Messages*, GC21-5076.

### Sort Operating Procedure

A complete file can be sorted or a file can be sorted after selected card types are removed. The first method is a simple sort; the second is a sort with omits.

#### Sort (No Omits):

1. Clear cards from the MFCU or MFCM.
2. Divide the card deck to be sorted. Place approximately one-half of the card deck in the primary hopper and the remaining cards in the secondary hopper.
3. Be sure that an end-of-file (/\*) card is behind cards in each hopper.
4. Press MFCU or MFCM START.

5. Start the partition by selecting option 0.
6. Cards are read in from both hoppers and selected into four stackers. If a stacker fills before the hoppers are empty, take the cards from the stacker and set them aside.
7. When the pass is completed, the partition issues an EP message. If printing is specified, a message indicating the number of passes remaining and the action required for the next pass is printed on the system printer.

*Note:* It is recommended that you allow the messages to be printed until you are familiar with the placement of cards for the next pass.

8. Clear the I/O device and remove the end-of-file cards. Place the cards for the next pass in the hoppers using the printed messages as a guide. Place any cards set aside when stacker 1 was filled in front of the cards from stacker 1. The same procedure applies for stackers 2, 3, and 4. (See Note 2 following this procedure.)
9. Place end-of-file cards behind the decks in both hoppers.
10. Press MFCU or MFCM START.
11. Start the partition by taking the 0 option.
12. The second pass of the sort is run and the partition again issues an EP message.
13. Repeat steps 8 through 12 until all cards are routed into stacker 1. At this time, the sort is complete.

*Notes:*

1. If a message other than EP or EJ occurs during the sort run, check the list of program messages in *IBM System/3 Model 15 System Messages*, GC21-5076.
2. If you forget to remove one of the end-of-file cards (/\*) from under the cards after a pass (step 8), the following procedure can save an extra pass:
  - a. Remove end-of-file cards from behind cards in both hoppers and let the pass continue.
  - b. Wait for the I/O device not ready message. One hopper is empty and the other hopper has cards in it. The cards remaining in the hopper are there because the system has read the misplaced end-of-file card and does not expect any more cards from that hopper, but is looking for more cards from the empty hopper.

- c. Remove remaining cards from the hopper and place them in the empty hopper.
- d. Place the end-of-file card after the cards in the hopper.
- e. Press MFCU or MFCM START. Continue with the pass.

*Sort (With Omits):*

1. Clear cards from the MFCU or MFCM.
2. Divide the card deck to be sorted. Place approximately one-half of the card deck in the primary hopper and the remaining cards in the secondary hopper.
3. Be sure there is an end-of-file (/\*) card behind the cards in each hopper.
4. Press MFCU or MFCM START.
5. Start the partition by selecting option 0.
6. Cards are read from both hoppers and selected into four stackers. If a stacker fills before hoppers empty, take the cards from the stacker and set them aside.
7. When the pass is completed, the partition issues the EO message. If printing is specified, a message indicating the number of passes remaining and the action required for the next pass is printed on the system printer.
8. Clear the I/O device and remove the end-of-file (/\*) cards.
9. Take the cards from stackers 2 and 4 and set them aside. These are the omitted cards.

10. Place any cards that were set aside when stacker 1 filled (step 6) in front of the cards from stacker 1 and place these cards in the primary hopper.
11. Place cards from stacker 3 in the secondary hopper, using the procedure in step 10 if cards were set aside when stacker 3 filled.
12. Place end-of-file (/\*) cards behind the decks in both hoppers.
13. Press MFCU or MFCM START.
14. Start the partition by taking the 0 option.
15. The second pass of the sort is run and the partition issues the EP message.
16. Repeat steps 8-13 of the procedure under *Sort (No-Omits)*.

*Note:* It is recommended that you allow the messages to be printed until you are familiar with the placement of cards for the next pass.

*Note:* If you forget to remove one of the end-of-file cards (/\*) from under the cards after a pass, you can save yourself an extra pass by doing the following:

1. Remove end-of-file cards from behind cards in both hoppers and let the pass continue.
2. Wait for the I/O device not ready message. One hopper is empty and the other hopper has cards in it. The cards remaining in the hopper are there because the system has read the misplaced end-of-file card. It does not expect any more cards from that hopper, but is looking for more cards from the empty hopper.
3. Remove remaining cards from hopper and place them in empty hopper.
4. Place end-of-file card after cards in hopper.
5. Press MFCU or MFCM START. Continue to pass.

*Merge:* Merge is a one-pass operation.

1. Clear cards from the MFCU or MFCM.
2. Place the primary file in the primary hopper. The last card must be an end-of-file card (/\*).
3. Place the secondary file in the secondary hopper. The last card must be an end-of-file card (/\*).
4. Press MFCU or MFCM START.
5. Start the partition by taking option 0.
6. Cards are read in from both hoppers, merged and routed to stacker 1.

A sequence error causes the system to issue the E1 (primary hopper) or E2 (secondary hopper) message. The recovery procedures for these errors are included in the list of program messages in the *IBM System/3 Model 15 System Messages*, GC21-5076. Any omit cards from the primary hopper go to stacker 2; any omit cards from the secondary hopper go to stacker 4.

When the pass is complete and a message other than end of job is displayed, check the list of program halts in *IBM System/3 Model 15 System Messages*, GC21-5076.

*Match:* The program run sheet should indicate which type of output appears in which stacker.

1. Clear cards from the MFCU or MFCM.
2. Place the primary file in the primary hopper. The last card must be an end-of-file card (/\*).
3. Place the secondary file in the secondary hopper. The last card must be an end-of-file card (/\*).
4. Press MFCU or MFCM START.
5. Start the partition by taking option 0.
6. Cards are routed to any or all stackers.

A sequence error causes the partition to issue the E1 (primary hopper) or E2 (secondary hopper) message. The recovery procedures for these errors are included in the list of program messages in *IBM System/3 Model 15 System Messages*, GC21-5076.

When the pass is completed and a message other than end of job is displayed, check the list of program messages in the *IBM System/3 Model 15 System Messages*, GC21-5076.

*Select:*

1. Clear cards from the MFCU or MFCM.
2. Place the file in the primary hopper. The last card must be an end-of-file card (/ \*).
3. Press MFCU or MFCM START.
4. Start the partition by taking option 0.
5. Cards are routed to the stackers as follows:
  - a. Nonselected cards to stacker 4.
  - b. Selected cards to any or all of the remaining stackers (1, 2, and 3).

A sequence error in a sequenced file causes the partition to issue the E1 message. The recovery procedure for this error is in *IBM System/3 Model 15 System Messages*, GC21-5076.

When the pass is completed and a message other than end of job is displayed, check the list of program messages in *IBM System/3 Model 15 System Messages*, GC21-5076.

**List Program**

The list program can be used with any of the card input devices.

1. Mount the disk cartridge, if one is specified on the program run sheet, and ready the disk device.
2. Clear cards from the card reader.
3. Place OCL statements and the cards to be listed in the system input device in the following order:
  - a. OCL statements
  - b. The deck to be listed
  - c. Two end-of-file cards (/ \*)
4. Start the card reader.
5. Ready the printer.

6. Start the partition. After the program is loaded, the partition issues a CU message. If CU is not displayed, check the list of program messages in *IBM System/3 Model 15 System Messages*, GC21-5076.

The following options can be selected when you respond to the message. See the program run sheet for the desired option:

Option	Meaning
0	Card count only; no listing
1	Single space with card count
2	Double space with card count
3	Triple space with card count

Any option other than 0 through 3 selects the double-space-with-card-count option (same as 2).

7. Start the partition by selecting the desired option. All the cards go into stacker 1. When the end-of-file cards (/ \* ) are read, the partition issues the 52 message. If there are no more list jobs to run, proceed to step 8. If more list jobs are to be run, follow the steps under *Restart Procedure*.
8. Start the partition by selecting option 2. The program ends.

*Restart Procedure:*

1. Start the partition by taking option 1. The message changes to CU.
2. Place the cards needed for this run in the system input device (if they are not already there) and ready the reader.
3. Repeat operating procedure starting at step 7.

## Reproduce/Interpret Program

This program can be used with the MFCU, MFCM or 1442/2501 combination. If you are using the same file for input and output, spooling cannot be used.

1. Mount the proper disk cartridge, if one is specified on the program run sheet, and ready the disk devices.
2. Clear cards from the card device.
3. Place OCL statements, followed by cards required for the job, in the primary hopper of the MFCU or MFCM or in the 2501 hopper. Be sure two end-of-file (/\*) cards are at the end of the deck. Several reproduce and interpret jobs can be placed in the device at the same time. Place the cards in the following order:
  - a. OCL statements.
  - b. Reformat data cards with a /\* card at the end
  - c. The cards to be reformatted (if applicable) or the cards to be reproduced or interpreted.
  - d. Two end-of-file cards (/\*) .
4. Place blank cards (if necessary) in the secondary hopper of the MFCU or MFCM, or in the 1442 hopper if the 1442/2501 combination is used.
5. Start the card devices.

6. Start the partition. After the program is loaded, the partition issues the CU message. If this message is not displayed, check the list of program messages in *IBM System/3 Model 15 System Messages*, GC21-5076.

The following program options can be entered with your message response. See the program run sheet for the desired option:

Option	Meaning
0	Read and interpret (print as punched)
1	Reproduce (punch a new card deck)
2	Reproduce and interpret (punch and print on cards)
3	Reproduce with reformatting
4	Reproduce and interpret with reformatting

Any program option other than 0 through 4 selects the reproduce and interpret option (option 2) when the MFCU or MFCM is used. When the 2501/1442 is used, the default is option 1. If the device used does not support printing, any requested printing is ignored.

7. Start the partition selecting the desired option. Cards from the primary hopper (or 2501) and secondary hopper (or 1442) go to their respective default stackers. When two consecutive end-of-file (/\*) cards are read, the partition issues the 52 message.
8. If there are no more reproduce and interpret jobs to run, start the partition by taking option 2. The program ends. If more reproduce and interpret jobs are to be run, follow the steps under *Restart Procedure*.



**Restart Procedure:**

1. Start the partition by taking option 1. The CU message is displayed.
2. Place cards needed for this run in proper hoppers (if they are not already there) and ready the device.
3. Repeat operating procedure starting at step 7.

**Reformat Data Card**

If reformatting is needed, reformat data cards must be punched to indicate the format of the new deck. A reformat unit of six card columns is required to reformat a field. Up to 100 reformat units can be used. (A field is one or more columns on a card that contains the same or related information.) Several reformat units may be placed on one card or each unit can be placed on a separate card.

Figure 47 shows the format of a reformat data card. When reformatting is specified, all cards are reformatted except those with a /\* in columns 1 and 2; these cards are reproduced in their original format.

1	2	3	4	5	6	7	8
0	1	0	4	0	8		
a	a	b	b	c	c		
These six columns make one reformat unit							
A field beginning in column 01 (aa)		and ending in column 04 (bb) is being reproduced.				It will be reformatted so that in the new deck it will end in column 08 (cc). Therefore, the reformatted field will begin in column 05 in the new deck.	

**Figure 47. Reformat Data Card Format**

**Moving Fields:** In this example, we want to switch fields 1 and 2. Figure 48 shows the format of the cards to be reformatted, the reformat data card, and the format of the new deck.

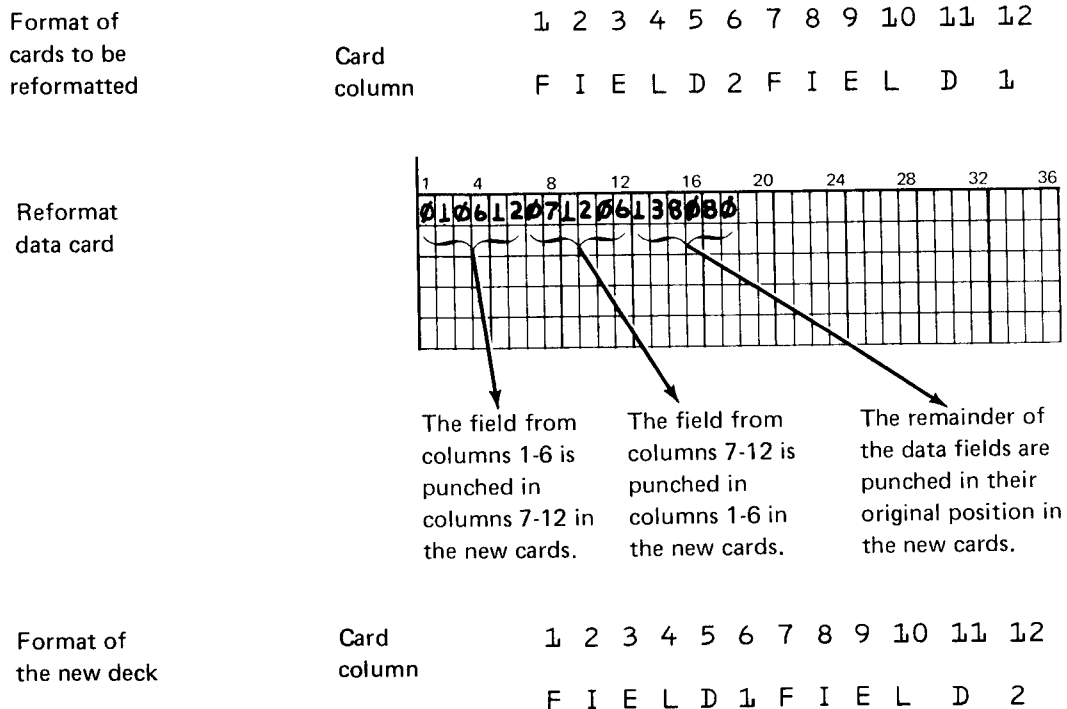

**Figure 48. Moving Fields**

*Deleting a Field:* In this example, we want to delete Field 6. Figure 49 shows the deck to be reformatted, the reformat data card, and the format of the new deck. Note that columns 57-62 (field 6) are not punched on the new cards because these columns are not included in the format data card.

Deck to be reformatted

Card column

```

51 52 53 54 55 56 57 58 59 60 61 62 63 64 65 66 67 68
F I E L D 5 F I E L D 6 F I E L D 7

```

Reformat data card

0	1	5	6	5	6	6	3	8	0	8	0						
a	a	b	b	c	c	a	a	b	b	c	c						
All fields from columns 1-56 are punched in the same position in the new cards.						All fields from columns 63-80 are punched in the same position in the new cards.											

Format of new deck

Card column

```

51 52 53 54 55 56 57 58 59 60 61 62 63 64 65 66 67 68
F I E L D 5                               F I E L D 7

```

Figure 49. Deleting a Field

## Gangpunch Program

This program is used to punch information obtained from one card (a master card) into subsequent cards (detail cards). The information to be punched can also come from a counter or a constant specified in the specification cards. If the same file is used for input and output or if stacker selection is specified, spooling cannot be used.

### *Interspersed Master-Card Gangpunching*

This type of gangpunching can only be done using the MFCU, MFCM, or 1442.

1. Mount the disk cartridge, if one is specified on the program run sheet, and ready the disk device.
2. Clear cards from the reader.
3. Place OCL statements and the gangpunching control statements in the system input device in the following order:
  - a. OCL statements
  - b. Header control statement
  - c. Field definition control statement(s)
  - d. /\* card
4. Place the deck of master and detail cards in the reader hopper (primary hopper if using the MFCU or MFCM).
5. Place two end-of-file cards (/\*) after the last detail card.
6. Start the card reader.
7. Ready the printer.
8. Start the partition. The program performs the requested functions.

See *IBM System/3 Model 15 System Messages*, GC21-5076, for any programmed messages and how to respond to them.

## *Count-Controlled Gangpunching*

Count-controlled gangpunching can be done using the MFCU, MFCM, or 2501/1442 combination.

1. Mount the disk cartridge, if one is specified on the program run sheet, and ready the disk device.
2. Clear cards from the readers.
3. Place the OCL statements and the gangpunch control statements in the system input device in the following order:
  - a. OCL statements
  - b. Header control statement
  - c. Field definition control statements
  - d. /\* card
4. Place the master cards, followed by two /\* cards, in one of the following, as applicable:  
  
MFCU secondary hopper  
MFCM secondary hopper  
2501 hopper
5. Place the detail cards, followed by two /\* cards, in one of the following, as applicable:  
  
MFCU primary hopper  
MFCM primary hopper  
1442 hopper
6. Start the card device(s).
7. Ready the printer.
8. Start the partition. The program performs the requested functions.

See *IBM System/3 Model 15 System Messages*, GC21-5076, for any programmed messages and how to respond to them.

### *Match Field Gangpunching*

This type of gangpunching can be done using the MFCU, MFCM, or 2501/1442 combination.

1. Mount the disk cartridge, as specified on the program run sheet, and ready the disk device.
2. Clear cards from the readers.
3. Place OCL statements and gangpunch control statements in the system input device in the following order:
  - a. OCL statements
  - b. Header control statements
  - c. Field definition control statement
  - d. /\* card
4. Place the master cards, followed by two /\* cards, in one of the following, as applicable:
  - MFCU secondary hopper
  - MFCM secondary hopper
  - 2501 hopper
5. Place the detail cards, followed by two /\* cards, in one of the following, as applicable:
  - MFCU primary hopper
  - MFCM primary hopper
  - 1442 hopper
6. Start the card readers.
7. Ready the printer.
8. Start the partition. The program performs the requested functions.

See *IBM System/3 Model 15 System Messages*, GC21-5076, for any programmed messages and how to respond to them.

- Removing Cards Prior to Restarting a Checkpoint Program
- Restarting a Checkpoint Program
- Intervening programs

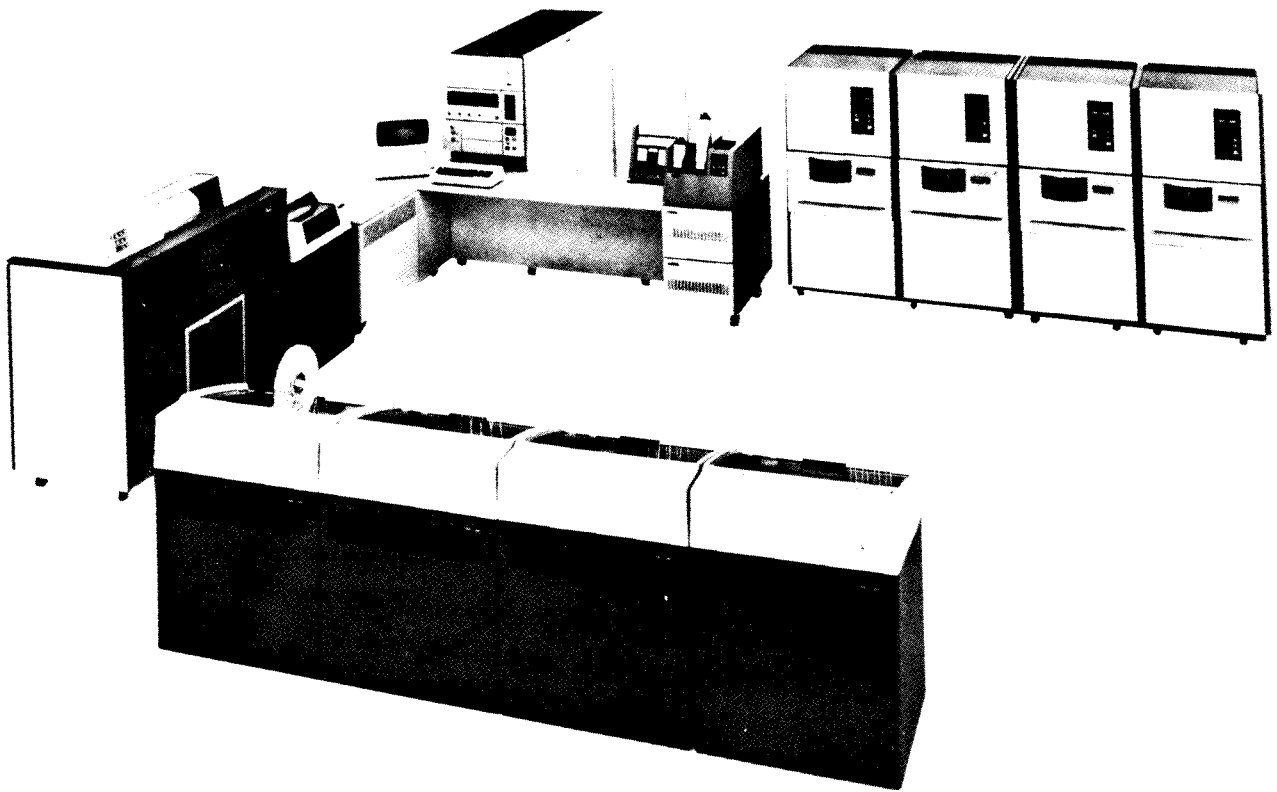

Checkpoint is a means of recording the status of a program at desired intervals. Restart is the facility to resume the execution of the checkpoint program from the last checkpoint rather than from the beginning, if processing is terminated for any reason (except controlled cancel) before the normal end of job. For example, some malfunctions such as a power failure may cause an interruption to the program execution. By using restart, you can begin execution of the interrupted program at the point of the last previous checkpoint. No intervening program executions are allowed between the failure and the restart. The checkpoint request is accepted only if the checkpoint program is executed in partition 1 and file sharing is not being used (5704-SC2 only). If the partition size is equal to or greater than 48K when using Program Number 5704-SC2, an HH48 message is issued, which requires the user to respond by taking a recovery option 0 or 3. Recovery option 0 sets the checkpointed partition at 48K and recovery option 3 ignores the checkpoint request.

*Note:* Compilers and the overlay linkage editor should not run in partition 2 in conjunction with a LOAD \* checkpoint program or temporary checkpoint program.

If the checkpoint program is terminated (immediate cancel) and if another program is cataloged, the checkpoint program may be deleted before restart.

When message HY is displayed on the CRT screen, perform the following procedures before the checkpoint request is accepted (the program run sheet for the checkpoint program should provide repositioning aids).

1. If the MFCU or MFCM is being used, remove cards from stackers and set them aside. They will not be used again by this job.
2. If the printer is being used, record the number of the line printed so the paper in the printer can be repositioned to this line if the program must be restarted. If a special print chain is used for the job, make note of it.
3. If the 2501 or 1442 is being used, remove the cards from the stackers and set them aside. They will not be used again for this job.
4. If tape is being used, record the external label information so the proper tape reel can be remounted and rewound if the program must be restarted.
5. If disk is being used, record the pack identifications so the correct packs can be remounted if the program must be restarted.

6. If the 3741 is being used as an input device, record the current disk address so the diskette can be repositioned if the program must be restarted.
7. If the 3741 is being used as an output device, (1) take the 3741 offline, (2) search to EOD and record advance, and (3) record the current disk address. This must be done so the diskette can be repositioned if the program must be restarted.
8. Respond to the HY message with the 0 option to allow the checkpoint program to continue.

#### REMOVING CARDS PRIOR TO RESTARTING A CHECKPOINT PROGRAM

1. Check the program run sheet to determine if the MFCU or MFCM was being used. If not, proceed to step 7.
2. Remove cards from the primary hopper. Note that these cards came from the primary hopper. You will have to use these cards later.
3. Press NPRO on the MFCU or MFCM. Place cards fed into stacker 1 in front of cards removed from the primary hopper.
4. Remove cards from the secondary hopper. Note that these cards came from the secondary hopper. You will have to use these cards later.
5. Press NPRO on the MFCU or MFCM. Place cards fed into stacker 2 in front of cards removed from the secondary hopper.
6. Remove any cards from stackers and place them in the proper order in front of the cards for the appropriate hopper.

*Note:* Be sure the sequence in which the cards in the stackers were originally processed is maintained to ensure that they are reprocessed in the same sequence.

7. Check the program run sheet to determine if the checkpoint program was using the 2501 or 1442. If so, remove the cards from the hopper. Press NPRO on the 1442 or 2501. Place all the cards from the stackers in front of the cards removed from the hopper.

*Note:* Be sure the sequence in which the cards from the stackers were processed is maintained to ensure that they are reprocessed in the same sequence.

8. Remove disk cartridges or packs or tapes as specified on program run sheet.

## RESTARTING A CHECKPOINT PROGRAM

Spooling must be inactive in partition 1 or must be stopped via the STOP command.

1. Enter the following OCL statements:

```
//RSTRT JOB PARTITION-1
// LOAD $$RSTR,unit
// RUN
```

*Note:* In order to guarantee the required minimum size for partition 2, a SET command may be required. Also, to reestablish the proper log device, a LOG statement may be required.

2. One of the following messages may be displayed on the CRT screen:

H~~B~~AC—attempted restart without an active checkpoint.

H~~B~~CS—reserved storage with the SET command required by the checkpoint program. Proceed to step 9 to cancel.

H~~B~~SP—attempted restart with spooling active in partition 1. Proceed to step 9 to cancel.

H~~B~~nn—where nn is the number of the required checkpoint. You may:

- a. Cancel and proceed to step 9.
- b. Control cancel to delete the active checkpoint and immediate cancel. Proceed to step 9.
- c. Check the program run sheet to determine if the checkpoint program was using the MFCU or MFCM. If not, proceed to step 4.

3. Place cards back in appropriate hoppers of the MFCU or MFCM and start the device.
4. Check the program run sheet to determine if the checkpoint program was using the printer. If the printer was not being used, proceed to step 6.
5. Reposition the paper in the printer to the line that was being printed when the last checkpoint was accepted. Make sure the proper print chain is mounted:
  - a. Disengage the manual feed clutch.
  - b. Position the forms using the vertical adjustment knob until the crease between the forms is aligned with the upper scribe line on the forms guide.
  - c. Press CARRIAGE RESTORE.
  - d. Engage the manual feed clutch.
  - e. Press the CARRIAGE SPACE key until the paper is at the line at which the checkpoint was accepted.
  - f. Press printer START.

6. Check the program run sheet to determine if the checkpoint program was using the 2501 or 1442. If not, proceed to step 8.

7. Place cards back in the hopper of the 2501 or 1442 and start the device.

8. Mount disk cartridges or packs and tape reels, as recorded at the checkpoint, on the appropriate drives and ready them.

9. If the 3741 was being used, reposition the diskette to the address of the record being processed when the last checkpoint was accepted and make the 3741 ready.

10. Select option 0 to the H~~B~~ message to allow the job to restart. Select option 2 to deactivate the checkpoint and immediate cancel, or option 3 to cancel the job.

11. If you canceled the job via the 3 option, go to step 1.
12. If HØ occurs again:
  - a. If the program uses tape files, you may have to mount a different tape reel or rewind the reel that is on the tape unit. When the proper tape reel is mounted, select option 1 to allow the job to continue or option 3 to cancel the job. If the message recurs for the same tape unit, the file label or volume sequence number of the mounted tape does not match the file label or volume sequence number of the tape mounted at the last checkpoint. Mount the correct tape and select the appropriate option as in the preceding paragraph. If volumes of a multireel file were processed out of sequence, select option 0.
  - b. You may have mounted the wrong disk cartridge. After you have checked that the correct cartridge is mounted, select option 1 to allow the job to continue or option 3 to cancel the job.

If any other messages occur during the preceding procedures, refer to the *IBM System/3 Model 15 System Messages, GC21-5076*, for recovery procedures.

## INTERVENING PROGRAMS

Programs can be executed prior to the restart of a checkpoint program. The following list should be observed because there is no system protection provided:

- The checkpoint program must have been permanently cataloged. (LOAD \* must not be used.)
- If any tapes are processed by the basic tape access method (BTAM) or by direct call to tape IOS in the checkpoint program, they must be dismounted to allow the intervening program to use the tape units. The user's restart routine must reposition the tapes to the status at the active checkpoint.
- \$MAINT must not be executed during the time between failure and restart of the checkpoint program.
- The RPG II, FORTRAN, and COBOL compilers, the assembler, and the overlay linkage editor can be executed if the object program is punched or cataloged to a pack other than the program (load) pack of the checkpoint program. Anything with the same name as the checkpoint program cannot be cataloged on the program pack of the checkpoint program.
- Intervening programs must not access disk volumes used by the active checkpoint program for new or scratch files.
- Disk files used by the checkpoint program should not be modified by an intervening program if the user's restart routine restores selected records in the files. This destroys the updates of the intervening program.
- The disk packs online at restart must be the same packs as those used by the checkpoint program at the last checkpoint.
- Intervening and active checkpoint programs must not add to the same file.

*Note:* The checkpoint must be deactivated before loading a rollout evoking program or loading a checkpoint program into partition 1. Rollout is not supported by System Control Program Number 5704-SC2.

- The \$DELET function (FORMAT statement) must not be used to deallocate space that does not contain files, libraries, or system areas on any packs used by the checkpoint program.







**HN Print Chain**

F1	F2	F3	F4	F5	F6	F7	F8	F9	F0	7E	7D	61	E2	E3	E4	E5	E6	E7	E8	E9	50	6B	4D
1	2	3	4	5	6	7	8	9	0	=	'	/	S	T	U	V	W	X	Y	Z	&	,	(

D1	D2	D3	D4	D5	D6	D7	D8	D9	60	5B	5C	C1	C2	C3	C4	C5	C6	C7	C8	C9	4E	4B	5D
J	K	L	M	N	O	P	Q	R	-	\$	*	A	B	C	D	E	F	G	H	I	+	.	)

**AN Print Chain**

F1	F2	F3	F4	F5	F6	F7	F8	F9	F0	7B	7C	61	E2	E3	E4	E5	E6	E7	E8	E9	50	6B	6C
1	2	3	4	5	6	7	8	9	0	#	@	/	S	T	U	V	W	X	Y	Z	&	,	%

D1	D2	D3	D4	D5	D6	D7	D8	D9	60	5B	5C	C1	C2	C3	C4	C5	C6	C7	C8	C9	4E	4B	4C
J	K	L	M	N	O	P	Q	R	-	\$	*	A	B	C	D	E	F	G	H	I	+	.	∩

**PN Print Chain**

F1	F2	F3	F4	F5	F6	F7	F8	F9	F0	E7	E8	61	E2	E3	E4	E5	E6	4F	7A	6D	7F	6B	7E
1	2	3	4	5	6	7	8	9	0	X	Y	/	S	T	U	V	W		:	_	"	,	=

D1	D2	D3	D4	D5	D6	D7	D8	D9	60	E9	4D	C1	C2	C3	C4	C5	C6	C7	C8	C9	4E	4B	5D
J	K	L	M	N	O	P	Q	R	-	Z	(	A	B	C	D	E	F	G	H	I	+	.	)

6C	5B	5C	7B	50	7C	4C	5E	5F	7D	6F	6E
%	\$	*	#	&	@	<	;	~	'	?	>



To determine a malfunctioning device or program, and who should correct it, you can follow a prescribed procedure called *problem determination*. Problem determination does not give you the precise cause of malfunction nor correct it, but it can reduce the amount of system down time if performed prior to calling IBM.

### PERFORMING PROBLEM DETERMINATION

In the following discussion, the meanings of indicators that show various types of failures are included. Also, when possible, you are told whether the failure is the result of a machine or user error.

#### Messages

Messages displayed on the CRT screen indicate incorrect program operation, machine errors, or in some cases information or instructions. All error codes and messages are logged to the system history area. Whenever a programmed message occurs, take the action indicated in the *IBM System/3 Model 15 System Messages*, GC21-5076.

#### Program Checks

Program checks are caused by programming malfunctions. They include:

- Invalid address
- Invalid op (operation) code
- Invalid Q byte
- Storage violation
- Privileged op (operation) violation

Program checks are indicated by a red light on the system control panel or by the message VF 04 PC being displayed on the CRT screen.

#### Error Message

If the error message VF 04 PC is displayed on the CRT screen, the program check occurred in the job executing in the partition identified in the message. The job is terminated. You can dump the contents of the partition in which the program check occurred by responding to the message with the D option. After you have responded to the message (and after the dump if you respond with the D option), you can continue processing by initiating a job in the partition.

## Processor Checks

A processor check is indicated when the PROCESSOR CHECK light on the system control panel turns on. A processor check is the result of an abnormal condition in the processing unit. The system stops. The cause of the processor check is indicated by position 8 on the register display unit on the processing unit display panel. A processor check can be caused by:

1. A program check in interrupt levels 1 through 6.
2. An invalid op program check in interrupt level zero.
3. An invalid Q-byte program check in interrupt level zero.
4. A hardware malfunction in the processing unit.

When the system stops with a processor check caused by items 1, 2, or 3, the following information needed for problem determination is retained by the system:

- Type of check
- Contents of the local storage registers (LSRs)

This information is not retained if the processor check is caused by a hardware malfunction. More detail about how and where this information is retained is in *IBM System/3 Model 15 System Data Areas and Diagnostic Aids*, SY21-0032 (5704-SC1), or the *IBM System/3 Model 15 System Data Areas and Diagnostic Aids*, SY21-0052 (5704-SC2).

## Operator Procedures for Processor Checks

Use this procedure to obtain the information needed for problem determination. Information on how to use the register display unit is contained in *Chapter 16. Terminating System/Program Operation*.

1. Set the register display unit to position 8 (PROC CHK) and record the type of check.
2. If the type of check does not indicate a hardware error, go to step 3. Otherwise, retry the job. If the error persists, contact IBM for assistance.
3. Record all information available from the register display unit.
4. Execute a storage dump by setting the ADDRESS DATA switches to F, pressing SYSTEM RESET, and pressing START. The contents of the index registers and storage are printed.
5. When halt 50 occurs in the message display unit, perform the IPL process.
6. Have a program listing, program output, dump output, and the information you recorded in step 3 available. Contact IBM for assistance.

It is the programmer's responsibility to determine the cause of a program loop. He should thoroughly examine the logic of his program to make sure he did not code a loop. If his program appears to be coded correctly, he should have the information you supplied available and contact IBM for assistance.

There may be times when you need to operate your Model 15 as though it were a Model 10. This allows you to run jobs developed for use on a Model 10. To do this, you must perform the IPL process using a system pack for IBM System/3 Model 10 Disk System (Program Number 5702-SC1) version 10, modification 00 or later.

### CONSIDERATIONS

When you use your Model 15 as a Model 10, certain features may not be used because of incompatibilities between the systems. The following items must be noted:

- A Model 10 DPF (dual programming feature) system cannot use program level 2 on the Model 15.
- Model 10 support for RPO devices cannot be used on the Model 15.
- After the Model 10 IPL process, the system is in halt mode.
- The I/O configuration chosen during the Model 10 system generation must match or be equivalent to the Model 15 configuration. Note the following devices:
  - The CRT/keyboard cannot be used after the Model 10 IPL process.
  - The 5203 Printer Dual Carriage Feature is not available on the Model 15.
  - The 5471 Printer-Keyboard is not supported on the Model 15.
  - The 1270 Optical Character Reader (World Trade only) cannot be used on the Model 15.

### PROCEDURES

Use the following procedure to use Model 10 programming support on your Model 15.

1. Wait until both partitions are at end of job.
2. Turn off the power for the CRT/keyboard.
3. Load the appropriate disk packs.
4. Perform the IPL process from the disk pack containing the Model 10 programming support.
5. Run the Model 10 programs.

When you use the Model 10 programming support, any halts that occur are displayed in the message display unit on the system control panel. The START key on the system control panel must be pressed to reset any halts.

To return to normal Model 15 operation:

1. Wait until the end-of-job halt is displayed.
2. Turn on the power for the CRT/keyboard.
3. Load the appropriate disk packs.
4. Perform the IPL process from the disk pack containing the Model 15 programming support.
5. Run the Model 15 programs.





## Appendix D. Procedures for Applying Program Temporary Fixes (PTFs)

Before PTFs can be applied, the system should reside on disk unit F1. This system should contain the library maintenance program (\$MAINT). The program or modules to be fixed should have been copied to the unit specified on the HDR statement if they are not already there. For 5704-SC2 only, the unit specified on the HDR statement can be changed to allow patching of the module where it currently resides. PTFs can then be applied.

1. Mount the user distribution disk cartridge (PID pack) on R1 if required. This pack contains the PTF installation programs and procedures. If the PTF installation programs are on F1, then change the LOAD or CALL statement's unit parameter from R1 to F1. For 5704-SC1 only, add the following procedure override LOAD statement for every CALL statement:

```
// LOAD ,F1
```

2. Perform an IPL from F1 if required.
3. Load the PTF deck into a card reader. The PTF deck contains the replacement or additional information for a module. The PTF deck also includes all the OCL statements necessary to apply the PTF to the module(s).
4. Use the library maintenance program (\$MAINT) to copy the updated module(s) to other user packs as required, unless the PTF was applied using \$SGPVR. If the PTF was applied using \$SGPVR, the module(s) patched should not be copied to other user packs because they may contain support for different system or program configurations.

### Considerations

The operator should examine the comment cards in each PTF deck before actually applying the PTF. This check ensures that the PTF is the one required to fix the program.

When \$SGPTF is used to apply a PTF to a module, six tracks of work space are required on the 5444 disk pack or simulation area that contains the module to be patched.

If there is not enough space available for the \$WORK file used by \$SGPTR or \$SGPVR, a procedure override file statement can be used to change the file to any other supported disk drive.

Support personnel should not punch a module containing PTFs, or copy it to a file. When the module is copied back to the library, all the PTF logs for that module, except the last one, are removed.

The second procedure must be called for all \$SGPTR PTFs to copy the module(s) back to the library from the \$WORK file.

If an LM68DF or LM68LF message is issued during the second procedure for a \$SGPTR patch, be sure to take a 3 option to prevent the loss of both the \$WORK file and the module in the library.

*Note:* Since the PTF log sector may not hold all PTFs applied, support personnel should keep a log of all PTFs applied to the current release of a system. (See *PTF List Program* in this section.)

### PTF List Program

The PTF list program, \$SGLOG, is used to list all modules in the object library that have had a PTF applied to them.

To produce this list the following OCL statements must be prepared:

```
// LOAD $SGLOG, unit  
// RUN
```

The OCL statements are followed by these control statements:

```
// PTFLIST UNIT-unit  
// END
```

The unit can be any 5444 disk pack or simulation area. Any number of PTFLIST control statements can be supplied.

The list produced includes the library, name, and release level of the module. It also includes the PTF log number if one can be found in the PTF log sectors. If this number is the one reserved for \$SGFIX, then \$SGFIX is printed instead of the number.

Example:

```
// LOAD $SGLOG,R1
// RUN
// PTFLIST UNIT-R1
// PTFLIST UNIT-F1
// END
```

This example produces a list of all modules that have a PTF in the object libraries from R1 and F1.

## Appendix E. Operator Control Commands (OCC) Summary

Operator control commands (OCC) allow the operator to communicate with the system. All OCCs are entered from the CRT/keyboard. By using OCC, the operator can communicate with the system before, during, or after job execution.

The following conventions are used to illustrate the commands:

1. Uppercase letters and punctuation marks (except as described in items 3 and 4) must be entered exactly as shown.
2. Lowercase letters and terms represent variable information you supply depending on the operation you want performed.
3. Items in brackets [ ] are optional. You include or omit these items as required by the operation.
4. Items in braces { } indicate alternatives. You must enter one of the items.
5. Optional items that are underlined indicate the default value. If none of the items are entered, the default value is used.
6. Abbreviations, if applicable, are enclosed in parentheses ( ) below the operation or operand. These abbreviations can be entered in place of the keywords.
7. All operands are positional. Operands must be entered in the order shown. If any operand except the last is omitted, a comma must be entered in its place.

**Command**

**Operands**

**Function**

CANCEL  
(CN)

SPOOL  
(SP)

RDRQ, { jobname  
(RQ) characters\*\* }

PRTQ, { jobname  
(WQ) characters\*\* } [ stepname  
,characters\*\* ]

PCHQ, { jobname  
(PQ) characters\*\* } [ stepname  
,characters\*\* ]

\*RDRQ  
(\*RQ)  
 \*PRTQ  
(\*WQ)  
 \*PCHQ  
(\*PQ)

P1 [ .,2  
,3 ]

P2 [ .,2  
,3 ]

P3 [ .,2  
,3 ]

Cancels spooling support (at IPL only).

Cancels a job or a job step, or multiple jobs or job steps. (characters\*\* operand is for 5704-SC2 only.)

Cancels an entire queue.

Cancels program execution in a partition. The 2 or 3 following the P1, P2, or P3 indicates the option of the cancel. (P3 operand is for 5704-SC2 only.)

Command	Operands	Function
CHANGE (G)	CORE,size, $\left[ \begin{array}{c} \text{RDRQ} \\ \text{(RQ)} \end{array} \right], \left\{ \begin{array}{c} \text{jobname} \\ \text{characters**} \end{array} \right\}$	Changes the main storage requirements, number of copies, card type, forms type, partition assignment, or priority of a job or job step or multiple jobs or job steps. (characters** operand is for 5704-SC2 only.)
	CPY,[number], $\left\{ \begin{array}{c} \text{PRTQ} \\ \text{(WQ)} \\ \text{PCHQ} \\ \text{(PQ)} \end{array} \right\}, \left\{ \begin{array}{c} \text{jobname} \\ \text{characters**} \end{array} \right\} \left[ \begin{array}{c} \text{,stepname} \\ \text{,characters**} \end{array} \right]$	
	CRD,card type, $\left[ \begin{array}{c} \text{PCHQ} \\ \text{(PQ)} \end{array} \right], \left\{ \begin{array}{c} \text{jobname} \\ \text{characters**} \end{array} \right\} \left[ \begin{array}{c} \text{,stepname} \\ \text{,characters**} \end{array} \right]$	
	FRM,forms type, $\left[ \begin{array}{c} \text{PRTQ} \\ \text{(WQ)} \end{array} \right], \left\{ \begin{array}{c} \text{jobname} \\ \text{characters**} \end{array} \right\} \left[ \begin{array}{c} \text{,stepname} \\ \text{,characters**} \end{array} \right]$	
	PTN, $\left[ \begin{array}{c} 1 \\ 2 \\ 3 \\ \text{A} \\ \text{B} \\ \text{C} \\ \text{D} \end{array} \right], \left[ \begin{array}{c} \text{RDRQ} \\ \text{(RQ)} \end{array} \right], \left\{ \begin{array}{c} \text{jobname} \\ \text{characters**} \end{array} \right\}$	
DATE (DT)	PTY (Y) $\left\{ \begin{array}{c} (1) \\ (2) \\ (3) \\ (4) \\ (5) \end{array} \right\}, \left\{ \begin{array}{c} \text{RDRQ,} \\ \text{(RQ)} \\ \text{PRTQ,} \\ \text{(WQ)} \\ \text{PCHQ,} \\ \text{(PQ)} \end{array} \right\}, \left\{ \begin{array}{c} \text{jobname} \\ \text{characters**} \end{array} \right\} \left[ \begin{array}{c} \text{,stepname} \\ \text{,characters**} \\ \text{,stepname} \\ \text{,characters**} \end{array} \right]$	Sets the system and partition dates.
	$\left\{ \begin{array}{c} \text{mm/dd/yy} \\ \text{mmdyy} \\ \text{dd/mm/yy} \\ \text{ddmmyy} \end{array} \right\}$	

**Command**

**Operands**

**Function**

DISPLAY  
(D)

STATUS

[,P1  
,P2  
,P3  
,N]

HISTORY[,task] [,task] . . .  
(H)

SVAID  
(SV)

CORE

RDRQ  
(RQ)

PRTQ  
(WQ)

PCHQ  
(PQ)

Displays the system status, partition status, and area names.

Pn and N operands are for 5704-SC2 only.

Displays the history of the entire system or of one to seven tasks.

Task operands<sup>1</sup> are for 5704-SC2 only.

Displays service aids options.

Displays main storage.

Displays the contents of the spooling queues.

<sup>1</sup>Possible task operands are P1, P2, P3, S, SP, OCC, CCP, CCS, CCU, C44, C55, C66, C77, C88, C99, CCC, CDD, CEE, CGG, CHH, **CMM**, CPP, CTT, CUU, CVV, CWW, CXX, CYY, CZZ.

Command	Operands	Function
DUMP (K)	$\left( \begin{array}{l} P1 \left[ \begin{array}{l} .2 \\ .3 \end{array} \right] \\ P2 \left[ \begin{array}{l} .2 \\ .3 \end{array} \right] \\ P3 \left[ \begin{array}{l} .2 \\ .3 \end{array} \right] \\ \text{SYSTEM}[,DISK] \\ (S) \end{array} \right)$	Causes a dump of any partition or all of main storage to a printer; or dumps main storage, SWA, saved transient area, part of SHA, configuration records, PTF log sectors, microcode levels, and error recording data to \$SYSDUMP file. (P3 and DISK operands are for 5704-SC2 only.)
HALT (HT)	$\left[ \begin{array}{l} P1 \\ P2 \\ P3 \\ \text{SHA}[,CCP] [,tracks] \end{array} \right]$	Causes the partition to halt with an EJ or ES message after the current job step is complete.  Causes the system to halt or \$HACCP to be automatically invoked under CCP before unprinted system history area entries are overlaid. (CCP and tracks operands are for 5704-SC2 only.)
HIPTY (HP)	high-priority	Limits the priority of jobs placed on the active spool file reader queue by \$QCOPY under CCP (5704-SC2 only).
HOLD (H)	$\left( \begin{array}{l} \text{RDRQ} \left[ \begin{array}{l} ,jobname \\ ,characters** \end{array} \right] \\ \text{(RQ)} \\ \text{PRTQ} \left[ \begin{array}{l} ,jobname \\ ,characters** \end{array} \right] \left[ \begin{array}{l} ,stepname \\ ,characters** \end{array} \right] \\ \text{(WQ)} \\ \text{PCHQ} \left[ \begin{array}{l} ,jobname \\ ,characters** \end{array} \right] \left[ \begin{array}{l} ,stepname \\ ,characters** \end{array} \right] \\ \text{(PQ)} \end{array} \right)$	Prevents a job, a job step, multiple jobs or job steps or an entire queue from being scheduled for input or output. (characters** operand is for 5704-SC2 only.)
IDELETE (I)	--	Causes the system to automatically delete I-type (informational) messages that are unresponded to when messages must be responded to.
KEEP (KP)	$\left( \begin{array}{l} \text{RDRQ}, \left\{ \begin{array}{l} jobname \\ characters** \end{array} \right\} \\ \text{(RQ)} \\ \text{PRTQ}, \left\{ \begin{array}{l} jobname \\ characters** \end{array} \right\} \left[ \begin{array}{l} ,stepname \\ ,characters** \end{array} \right] \\ \text{(WQ)} \\ \text{PCHQ}, \left\{ \begin{array}{l} jobname \\ characters** \end{array} \right\} \left[ \begin{array}{l} ,stepname \\ ,characters** \end{array} \right] \\ \text{(PQ)} \end{array} \right)$	Keeps single or multiple printed, punched, or executed jobs and/or job steps on the queue (5704-SC2 only).
NOHALT (NHT)	$\left[ \begin{array}{l} P1 \\ P2 \\ P3 \\ \text{SHA} \end{array} \right]$	Changes the processing mode of a partition from halt to nohalt, or allows system history area entries to be overlaid without operator notification.

**This page is intentionally left blank.**



Command	Operands	Function
NODELETE (NI)	---	Causes the system to cease automatic deletion of I-type messages that are unresponded to.
PTY (Y)	$\left. \begin{array}{l} \text{SPOOL} \\ \text{(SP)} \\ \text{P1} \\ \text{P2} \\ \text{P3} \end{array} \right\} \left\{ \begin{array}{l} \cdot \\ = \\ - \end{array} \right\} \dots$	Changes the priority for the system tasks: spooling (reader, print writer, punch writer), partition 1, partition 2, and partition 3.
READER (RDR)	$\left[ \begin{array}{l} \text{P1} \\ \text{P2} \\ \text{P3} \end{array} \right] \text{,device}$	Changes the system input device for a partition.
RELEASE (R)	$\left. \begin{array}{l} \text{RDRQ} \left[ \begin{array}{l} \text{,jobname} \\ \text{,characters**} \end{array} \right] \\ \text{(RQ)} \\ \\ \text{PRTQ} \left[ \begin{array}{l} \text{,jobname} \\ \text{,characters**} \end{array} \right] \left[ \begin{array}{l} \text{,stepname} \\ \text{,characters**} \end{array} \right] \\ \text{(WQ)} \\ \\ \text{PCHQ} \left[ \begin{array}{l} \text{,jobname} \\ \text{,characters**} \end{array} \right] \left[ \begin{array}{l} \text{,stepname} \\ \text{,characters**} \end{array} \right] \\ \text{(PQ)} \end{array} \right\}$	Releases single or multiple jobs or job steps, or an entire queue, from the hold state. (characters** operand is for 5704-SC2 only.)
RESTART (T)	$\left[ \begin{array}{l} \text{PRT} \left[ \begin{array}{l} \text{,PAGE} \\ \text{(PG)} \\ \text{,number} \end{array} \right] \\ \text{(W)} \\ \\ \text{PR1} \left[ \begin{array}{l} \text{,PAGE} \\ \text{(PG)} \\ \text{,number} \end{array} \right] \\ \text{(W1)} \\ \\ \text{PR2} \left[ \begin{array}{l} \text{,PAGE} \\ \text{(PG)} \\ \text{,number} \end{array} \right] \\ \text{(W2)} \\ \\ \text{PCH} \\ \text{(P)} \end{array} \right]$	Restarts a job step's printed or punched output from the beginning. PR1 (W1) and PR2 (W2) are for 5704-SC2 only.
REUSE (RU)	$\left. \begin{array}{l} \text{PRTQ} \left[ \begin{array}{l} \text{,jobname} \\ \text{,stepname} \end{array} \right] \\ \text{(WQ)} \\ \\ \text{PCHQ} \left[ \begin{array}{l} \text{,jobname} \\ \text{,stepname} \end{array} \right] \\ \text{(PQ)} \end{array} \right\}$	Frees space in the spool file from the currently printing or punching job step (5704-SC2 only).
ROLLOUT (RO)		Interrupts a rollout evoking program to allow another program to be loaded and executed (5704-SC1 only).
SET	$\left[ \begin{array}{l} \text{P1} \\ \text{P2} \\ \text{P3} \\ \text{SH} \end{array} \right] \text{,size}$	Overrides the partition and file share size specified during system generation.
SIMULATE (SM)	$\left\{ \begin{array}{l} \text{ON} \\ \text{OFF} \end{array} \right\}$	Enables or disables 5444 simulation on 3340 drive 2 (5704-SC1 only).

Command	Operands	Function
START (S)	SPOOL (SP) [ ,P1 ,P2 ,P3 [,NEW] [,unit] [,size] [,track-group-size]	Restarts spooling in the designated partition.
	RDR[,ROLL] (R)	Starts spooling at IPL.
	PRT[,forms type] (W)	Starts the spooled reader, print writer, or punch writer. PR1 (W1) and PR2 (W2) are for 5704-SC2 only.
	PR1 [,forms type] (W1)	
	PR2 [,forms type] (W2)	
	PCH (P)	
	P1 P2 P3	Restarts program execution in a partition (5704-SC2 only).

## Appendix F. Dump to Disk Program

You must ensure that a file labeled \$SYSDUMP is on the main data area of the IPL pack before you use the dump-to-disk option of the OCC dump program. If more than one \$SYSDUMP file exists, the dump will be written to the file with the most recent date.

The minimum size of \$SYSDUMP depends on the main storage size of the system to be dumped. The following table will help you determine the size of \$SYSDUMP:

Main Storage Size in Bytes	Tracks
96K	21
128K	23
160K	26
192K	28
224K	31
256K	34
384K	44
512K	55

The following OCL and control statements can be used to create the \$SYSDUMP file using the \$COPY system service program:

```
// LOAD $COPY,unit  
// FILE NAME-COPYO,PACK-name,UNIT-name,  
//   RETAIN-P,LABEL-$SYSDUMP,TRACKS-nn  
// FILE NAME-COPYIN,UNIT-unit  
// RUN  
// COPYFILE OUTPUT-DISK  
// OUTDM DATAMGMT-DIRECT  
// END
```

A /\* record (end of file) must then be read by the input device listed as UNIT on the COPYIN statement.



## Appendix G. Print \$SYSDUMP File and System Configuration Record to Printer (\$CPRNT)

The contents of the \$SYSDUMP file can be printed by the print program \$CPRNT. The following OCL is required to run \$CPRNT without operator intervention; it prints the entire \$SYSDUMP file on the printer:

```
// LOAD $CPRNT,unit  
// FILE NAME-$SYSDUMP,UNIT-unit,PACK-name  
// RUN
```

The following OCL is required to run \$CPRNT with operator intervention and a choice of options. It allows the operator to select portions of the \$SYSDUMP file to be printed.

```
// LOAD $CPRNT,unit  
// SWITCH XXXXXXXX  
// FILE NAME-$SYSDUMP,UNIT-unit,PACK-name  
// RUN
```

The SWITCH statement indicates operator intervention requested without altering the existing set switch.

You should not run \$CPRNT and use the OCC dump-to-disk command simultaneously, because the printout of the \$SYSDUMP file will be invalid.

For a complete description of what is printed and how information is selected, see *IBM System/3 Model 15 System Data Areas and Diagnostic Aids*, SY21-0032 (for 5704-SC1) or SY21-0052 (for 5704-SC2).



## Bibliography

### SYSTEM CONTROL PROGRAMMING

*IBM System/3 Model 15 System Control Programming Concepts and Reference Manual*, GC21-5162 (for 5704-SC2)

*IBM System/3 Model 15 System Control Programming Macros Reference Manual*, GC21-7608

*IBM System/3 Model 15 System Control Programming Reference Manual*, GC21-5077 (for 5704-SC1)

*IBM System/3 Model 15 System Generation Reference Manual*, GC21-7616

*IBM System/3 Model 15 System Messages*, GC21-5076

*IBM System/3 Model 15 User's Guide to Spooling*, GC21-7632

### Communications

*IBM System/3 CCP Terminal Operator's Guide*, GC21-7580

*IBM System/3 Model 15 CCP System Operator's Guide*, GC21-7619

*IBM System/3 Multiline/Multipoint Binary Synchronous Communications Reference Manual*, GC21-7573

### PROGRAM PRODUCTS

*IBM System/3 Basic Assembler Reference Manual*, SC21-7509

*IBM System/3 COBOL Reference Manual*, GC28-6452

*IBM System/3 Disk Sort Reference Manual*, SC21-7522

*IBM System/3 FORTRAN IV Reference Manual*, SC28-6874

*IBM System/3 RPG II Reference Manual*, SC21-7504

*IBM System/3 Sort/Collate and Card Utilities Reference Manual*, SC21-7529

*IBM System/3 Tape Sort Reference Manual*, SC21-7572

### OTHER REFERENCES

*IBM System/3 Disk Concepts and Planning Guide*, GC21-7571

*IBM System/3 Model 15 Introduction*, GC21-5094

*IBM System/3 Model 15 Master Index*, GC21-5202

*IBM System/3 Model 15 3340 Direct Access Storage Facility Reference Manual*, GC21-5111

*IBM System/3 Models 8, 10, 12, and 15 Components Reference Manual*, GA21-9236

*IBM System/3 Overlay Linkage Editor Reference Manual*, GC21-7561

*IBM System/3 3741 Reference Manual*, GC21-5113

*IBM 3741 Data Station Operator's Guide*, GA21-9131





## Index

- /. OCL statement summary 220
- / & OCL statement summary 220
- \$\$BSDL (device counter logout program) 234
- \$ALT (alternate track assignment) program summary 238
- \$BUILD (alternate track rebuild) program summary 238
- \$CNFIG (configuration record) program summary 238
- \$COPY (copy/dump) program summary 238
- \$CPRINT (print program) description 277
- \$DCOPY (dump/restore) program summary 238
- \$DELET (file delete) program summary 238
- \$FCOMP (file compress) program summary 238
- \$HACCP (system history area copy) program summary 238
- \$HACCP, automatically invoking 173
- \$HIST (system history area display) program summary 238
- \$INIT (disk initialization) program summary 238
- \$KLEAN (chain cleaning) program summary 238
- \$LABEL (file and volume label display) program summary 238
- \$MAINT (library maintenance) program summary 238
- \$QCOPY (spool file copy) program summary 238
- \$RINDEX (recover index) program summary 238.1
- \$RSALT (reassign alternate track) program summary 238.1
- \$SCOPY (simulation area) program summary 238.1
- \$\$SGFIX 266
- \$\$SGLOG (PTF list program) 265
- \$\$SGPTF 265
- \$\$SGPTR 265
- \$\$SYSDUMP file
  - creation 275
  - print program 277
- \$TINIT (tape initialization) program summary 238.1
- \$TVES (tape error summary) program summary 239
- \$VTOC (5445 data interchange) program summary 239
- \$\$WVTOC (1000-file VTOC conversion) program summary 239
- \* (comment) OCL summary 220
- \*PCHQ operand, CANCEL command 149
- \*PQ (see \*PCHQ)
- \*PRTQ operand, CANCEL command 149
- \*RDRQ operand, CANCEL command 149
- \*RQ (see \*RDRQ)
- \*TIME comment 146
- \*WQ (see \*PRTQ)
  - > 128K ADDR BIT switch, 5415 12
  - > 64K ADDR BIT switch, 5415 12
- action, message 200
- ACU PWR (autocall unit power) OFF light, 5415 10
- ADDR (address) BIT switches, 5415 12
- ADDR INCREM (address increment) switch, 5415 13
- ADDRESS COMPARE light/switch, 5415 13
- ADDRESS/DATA switches, 5415 6
- adjustment knobs
  - 1403 Models 2 and 5 75
  - 1403-N1 print 92
- alter storage switch, CE control panel 13
- alternate track assignment program (\$ALT) summary 238
- alternate track rebuild program (\$BUILD) summary 238
- AN print chain image 259
- answer
  - automatic 234
  - manual 233
- area names display 159
- ASSIGN OCL statement
  - parameters 221
  - summary 216
- ATTENTION key
  - 3340 131
  - 3344 131
- ATTENTION light
  - MFCM 42
  - 2501 68
- ATTENTION, clearing I/O 140
- autocall request light 10
- autocall unit power off light 10
- automatic
  - answer 234
  - call 233
  - invocation of \$HACCP 173
  - message deletion 176

- back tab key, 3277 19
- backspace key, 3277 20
- bibliography 279
- binary synchronous communications adapter  
(see BSCA)
- brightness adjustment, CRT 16
- BRUSH INLK (interlock) light
  - 1403 Model N1 90
  - 1403 Models 2 and 5 73
- BSCA ATTN light, 5415 9
- BSCA LOCAL TEST switch, 5415 13
- BSCA OCL statement
  - parameters 221
  - summary 216
- BSCA panel, 5415 4,9
- BSCA STEP key, 5415 13
- BUSY light, 5415
  - BSCA panel 10
  - LCA panel 12
- call
  - automatic 233
  - manual 233
- CALL OCL statement
  - parameters 221
  - summary 216
- CALL REQUEST light, 5415 10
- CAN NOT ACCEPT message 70, 146, 196
- CANCEL command
  - description 148
  - summary 268
  - to terminate operations 205
- cancel key, 3277 23
- cancel options 204
- card clearing 138
- card jam
  - MFCM 44
  - MFCU 29
  - 1442 62
  - 2501 70
- card path
  - MFCM 44,45,47
  - MFCU 29
  - 1442 62
- card read punch (see 1442)
- card reader (see 2501)

- card removal
  - MFCM
    - cornering position 54
    - preprint position 51
    - primary input station 47
    - primary preread station 47
    - print station 51
    - punch station 49
    - punch station, special procedures 50
    - read station 48
    - secondary preread station 48
  - MFCU
    - corner station 32
    - hopper station 30
    - postprint position 54
    - print unit 32
    - punch unit 31
    - stacker area 33
    - stacker transport arm 55
  - 1442 62
  - 2501 70
- card type operand, CHANGE card type  
command 152
- card utilities operating procedures 244
- carriage control keys
  - 1403 Model N1 88
  - 1403 Models 2 and 5 73
- carriage control tape
  - 1403 Model N1 96
  - 1403 Models 2 and 5 79
- CARRIAGE RESTORE key
  - 1403 Model N1 88
  - 1403 Models 2 and 5 73
- CARRIAGE SPACE key
  - 1403 Model N1 88
  - 1403 Models 2 and 5 73
- CARRIAGE STOP key
  - 1403 Model N1 88
  - 1403 Models 2 and 5 72
- cartridge
  - 1403 Model N1 print train 100
  - 1403 Models 2 and 5 print chain 82
  - 3284 print ribbon 108
- CCP operand, HALT command 173
- CE aids, MFCU 29
- CE key, CE control panel 13
- CE MODE SELECTOR switch, 5415 13
- CE panel
  - description 12
  - indicator lights 13
  - location 4
  - selector switches 13
  - use 204
- chain cartridge, 1403 print 80
- chain cleaning program (\$KLEAN)
  - summary 238
- chain images, print 258

CHANGE commands  
  card type 152  
  copies 153  
  core 154  
  forms type 155  
  partition 156  
  priority 157  
  summary 269  
CHAR (character) PHASE light, 5415  
  BSCA panel 10  
  LCA panel 11  
CHAR parameter, IMAGE OCL statement 257  
character insert key, 3277 22  
characters\*\* operand  
  CANCEL command 150  
  CHANGE card type command 152  
  CHANGE copies command 153  
  CHANGE core command 154  
  CHANGE forms type command 155  
  CHANGE partition command 156  
  CHANGE priority command 157  
  HOLD command 174.1  
  KEEP command 177  
  RELEASE command 183  
check bits display switch, 5415 12  
CHECK light  
  MFCM 46  
  1442 60  
check lights  
  MFCM 42  
  2501 68  
  5415 208  
check parity switch, 5415 13  
CHECK RESET key  
  CE control panel 13  
  1403 Model N1 88  
  1403 Models 2 and 5 73  
checkpoint/restart operation 253  
chip box emptying  
  MFCM 58  
  MFCU 39  
  1442 65  
CHIP BOX light, 1442 60  
CHIP light, MFCU 28  
clamp arms, 5444 123  
clarity adjustment, CRT 16  
cleaning, tape head 114  
cleaning, type face  
  1403 Model N1 102  
  1403 Models 2 and 5 85  
CLEAR key, 3277 20  
CLEAR TO SEND light, 5415  
  BSCA panel 10  
  LCA panel 11  
CLOCK lights, 5415 6  
clutch control knob, 1403 feed 91  
clutch light, 1442 feed 61  
CN (see CANCEL)  
CNCL (cancel) key, 3277 23  
codes, EJ completion 207  
collate/sort (see sort)  
commands (see OCC)  
comment OCL statement summary 220  
compare address switch/light, CE control panel 13  
COMPILE OCL statement  
  parameters 221  
  summary 216  
completion codes, EJ 207  
configuration record printing 277  
configuration record program (\$CNFIG) summary 238  
considerations  
  job mode cancel 204  
  system input device 211  
  tape 241  
console  
  (see also system console) 4  
  input device assignment 182  
contrast adjustment, CRT 16  
control keys  
  (see also controls)  
  console 7  
  MFCM 43  
  MFCU 31  
  1403 Model N1 88  
  1403 Models 2 and 5 73  
  1442 64  
  2501 69  
  3410/3411 112  
CONTROL MODE light, 5415 10  
control panel, system 5  
control tape (see carriage control tape)  
control, print quality  
  1403 Model N1 102  
  1403 Models 2 and 5 85  
controlled cancel (2) option 204  
controls  
  MFCM 42  
  MFCU 28  
  system 4  
  1403 Model N1 88  
  1403 Models 2 and 5 72  
  2501 68  
  3277 16  
  3284 104  
  3340 131  
  3344 131  
  3410/3411 112  
  5445 126  
conventions, OCC format 147  
copies, changing number of output 153  
copy control lever, 3284 104  
core dump command 171  
CORE operand, CHANGE core command 154  
core storage size, changing 154  
core storage, dumping 205

corner station card removal, MFCU 32  
 cornering position card removal, MFCM 54  
 count-controlled gangpunching  
   procedures 251  
 cover light, MFCU 28  
 COVER LOCKED indicator light, 3340 131  
 COVER LOWER key, 1403 Model N1 88  
 COVER RAISE key, 1403 Model N1 88  
 covers  
   machine vii  
   MFCM 46  
   MFCU 30  
   1403 Models 2 and 5 74  
   3340/3344 133  
 CPY operand, CHANGE copies command 153  
 CRD operand, CHANGE card type command 152  
 CRT  
   (see also screen, display, 3277)  
   formats 24  
   screen 16  
 CRT/keyboard input device assignment 182  
 cursor control keys, 3277 18  
 cursor, CRT 16  
 customer engineer (see CE)  
 CVR (cover) light, MFCU 28  
 cycle control display 6

data enter key, 3277 22  
 data interchange program (\$VTOC)  
   summary 239  
 data management screen format 25  
 DATA MODE light, 5415  
   BSCA panel 10  
   LCA panel 12  
 data module (3348)  
   loading/mounting 132  
   removal/unloading 133  
 data set ready light, 5415  
   BSCA panel 9  
   LCA panel 11  
 data station input device assignment 182  
 DATA switches, 5415 6  
 data terminal line in use light, 5415 BSCA  
   panel 10  
 data terminal ready light, 5415  
   BSCA panel 9  
   LCA panel 11  
 DATE command  
   description 158.1  
   summary 269  
 date considerations 212  
 DATE OCL statement  
   parameters 221  
   summary 217  
 date prompt 139

DEL (delete) key, 3277 22  
 deletion, information messages 176  
 density lever, 1403 print 78  
 density, print  
   1403 Model N1 102  
   1403 Models 2 and 5 85  
 device counter logout program  
   (\$BSDL) 234  
 device operand, READER command 182  
 DIGIT PRESENT light, 5415 10  
 DISABLE/ENABLE switch, 3410/3411 112  
 disk cartridge, 5440  
   mounting 121  
   removal 118  
 disk initialization program (\$INIT)  
   summary 238  
 DISK operand, DUMP command 172, 206  
 disk pack, 2316  
   mounting 129  
   removal 127  
 disk panel, 5415 4,8  
 disk resident card utility programs  
   operating procedures 244  
 disk sort program operating  
   procedures 243  
 disk storage drive  
   5444 117  
   5445 125  
 DISPLAY CHK BITS switch, 5415 12  
 DISPLAY command  
   description 159  
   summary 270  
 display formats 24  
 display panel, 5415 processing unit 6  
 display screen format 25  
 DISPLAY SELECT switch, 5415  
   BSCA panel 10  
   LCA panel 12  
 display selector switch (LSR), 5415 13  
 display storage switch, CE control  
   panel 13  
 display unit, 5415  
   cycle control 6  
   message 5  
   possible displays 201  
   register 6  
   use of 200  
 display, prompt 26  
 documentation, job vii  
 DT (data terminal) LINE IN USE light,  
   5415 10  
 DT (see DATE)  
 DT SET (data set) READY light, 5415  
   BSCA panel 9  
   LCA panel 11  
 DT TERM (data terminal) READY light, 5415  
   BSCA panel 9  
   LCA panel 11

dump (D) option 204  
DUMP command  
  description 171  
  summary 270.1  
  to terminate operations 205  
dump output sample 206.1  
dump/restore program (\$DCOPY)  
  operating procedures 240  
  summary 238  
dump to disk program 275  
dump, main storage 205  
D2 support on 3340 189

EJ (see end-of-job)  
emergency power off 7  
EMERGENCY PULL switch 7  
ENABLE/DISABLE switch, 3410/3411 112  
end-of-field erase key, 3277 20  
END OF FORMS light  
  1403 Model N1 89  
  1403 Models 2 and 5 72  
end-of-IPL display 139  
end-of-job completion codes 207  
end-of-job message 173, 178  
end-of-step message 173, 178  
end-of-tape marker 113  
end-of-tape marker indicator 112  
ENTER COMMAND prompt 26, 146  
ENTER DATA Pn prompt 25  
ENTER DISPLAY REQUEST prompt 25  
ENTER key, 3277 22  
ENTER READER DATA Pn prompt 26  
ENTER RESPONSE prompt 26, 200  
ENTER SYSTEM DATE prompt 139  
EOT (see end-of-tape)  
equal priority specification 180  
ERASE EOF (end of field) key, 3277 20  
ERASE INPUT key, 3277 20  
error log sheets 201  
ES (see end-of-step, STEP)  
execution, program  
  I-type 230  
  inquiry 230  
  object 229  
  starting 190  
  stopping 194  
  telecommunications 232  
EXT TEST SW (external test switch) light,  
  5415  
  BSCA panel 9  
  LCA panel 11

FEED CHECK light  
  MFCM 43,46  
  2501 69  
FEED CLU (clutch) light, 1442 61  
feed clutch control knob  
  1403 Model N1 91  
  1403 Models 2 and 5 75  
file and volume label display program  
  (\$LABEL) summary 238  
file compress program (\$FCOMP)  
  summary 238  
file delete program (\$DELET) summary 238  
FILE OCL statement  
  device independent file parameters 224  
  disk file parameters 222  
  summary 217  
  tape file parameters 223  
FILE PROTECT light, 3410/3411 112  
file share area size override/change 188  
file space, freeing spool 186  
FILE WRITE switch, CE control panel 12  
forced response to message 200  
formats  
  screen 25  
  system date 158.1  
formatting conventions, OCC 147  
FORMS CHECK light  
  1403 Model N1 89  
  1403 Models 2 and 5 72  
forms loading  
  1403 Model N1 97  
  1403 Models 2 and 5 80  
  3284 106  
forms stacking  
  1403 Model N1 98  
  1403 Models 2 and 5 81  
  3284 106  
forms thickness adjustments  
  1403 Model N1 102  
  1403 Models 2 and 4 85  
forms-thickness lever, 1403 Model N1 95  
forms type operand  
  CHANGE forms type command 155  
  START command 192  
forms type, changing 155  
FORTRAN inquiry program 230  
FRM operand, CHANGE forms type  
  command 155  
full SHA message 173, 178  
function keys  
  program 23  
  3277 17  
F2 support on 3340 189

G (see CHANGE)  
 gangpunch program operating  
   procedures 251  
 GATE INLK (interlock) light  
   1403 Model N1 90  
   1403 Models 2 and 5 73  
 G229-4098, Model 15A error log sheet 201  
 G229-8091, Model 15C-D error log  
   sheet 203  
 G229-8092, Model 15B error log sheet 202

H (see HISTORY, HOLD)  
 HALT command  
   description 173  
   summary 270.1  
 HALT OCL statement summary 217  
 handling, magnetic tape 115  
 head cleaning, tape 114  
 header labels, writing 197  
 HEX parameter, IMAGE OCL statement 257  
 hhmss operand, TIME command 196  
 high-priority operand, HIPTY command 174  
 high-speed data set test switch, CE control  
   panel 13  
 HIPTY command  
   description 174  
   summary 270.1  
 history area (see system history area)  
 history display 159  
 HISTORY operand, DISPLAY command 167  
 HN print chain image 259  
 HOLD command  
   description 174.1  
   summary 270.1  
 hopper check lights, MFCM 42  
 hopper input device assignment 182  
 hopper lights, MFCU 28  
 hopper misfeed card removal, 1442 62  
 hopper station card removal, MFCU 30  
 HOPR (hopper) light, 1442 61  
 horizontal positioning key, 3277 19  
 HPR (hopper no-feed) light, MFCU 28  
 HS (high-speed) START light  
   1403 Model N1 90  
   1403 Models 2 and 5 73  
 HS (high-speed) STOP light  
   1403 Model N1 90  
   1403 Models 2 and 5 73  
 HT (see HALT)

I (see IDELETE)  
 I/O ATTENTION light, 5415 5  
 I/O ATTENTION, clearing 140, 142  
 I/O CHECK light/switch, 5415 13  
 I/O OVERLAP switch, 5415 12

I-type message  
   deletion 176  
   response 200  
   retention 179  
 I-type program execution 230  
 IDELETE command  
   description 176  
   summary 270.1  
 IMAGE OCL statement  
   description 257  
   parameters 225  
   summary 217  
 immediate cancel (3) option 204  
 INCLUDE OCL statement  
   parameters 225  
   summary 217  
 incorrect response to message 200  
 increment storage address switch, CE  
   control panel 13  
 indicator lights  
   CE control panel 13  
   MFCM 42  
   processing unit 6  
   1403 Model N1 89  
   1403 Models 2 and 5 72  
   1442 60  
   2501 68  
   3277 24  
   3340 131  
   3344 131  
   3410/3411 112  
   5445 126  
 indicator panel lights  
   1403 Model N1 90  
   1403 Models 2 and 5 73  
 indicators  
   (see also indicator lights)  
   system console 4  
   1403 Model N1 88  
   1403 Models 2 and 5 72  
   1442 60  
   2501 68  
   3277 24  
   3340 131  
   3344 131  
   3410/3411 112  
   5445 126  
 information (I-type) messages  
   deletion 176  
   response 200  
   retention 179  
 initial program load (see IPL)  
 input device changing 182  
 input device considerations 211  
 input erase key, 3277 20  
 INPUT INHIBITED indicator light, 3277 24  
 input mode 210  
 inquiry program execution 230  
 INS (insert) MODE key, 3277 22  
 insert character key, 3277 22

INSERT MODE indicator light, 3277 24  
INT LEV (interrupt level) light, 5415 6  
interlock lights, 1403 Models 2 and 5 73  
interpret (see reproduce/interpret)  
interrupt level indicator light, 5415 6  
interruption, object program 230  
interruption, rollout-evoking program 187  
interspersed master-card gangpunching  
procedures 251  
intervening programs 256  
invoking \$HACCP 174  
IPL (initial program load) 138  
IPL unit selection 8

job

canceling 148  
documentation vii  
holding 174.1  
keeping on queue 177  
releasing 183  
stopping 173, 204

job mode

cancel considerations 204  
description 210

JOB OCL statement

parameters 225  
summary 218

job priorities, limiting 174

job step

canceling 148  
keeping on queue 177  
releasing 183  
restarting output 184.1

jobname operand

CANCEL command 150  
CHANGE card type command 152  
CHANGE copies command 153  
CHANGE core command 154  
CHANGE forms type command 155  
CHANGE partition command 156  
CHANGE priority command 157  
HOLD command 174.1  
KEEP command 177  
RELEASE command 183  
REUSE command 186

K (see DUMP)

KEEP command

description 177  
summary 270.1

keyboard, 3277 17

keys

CE control panel 13  
MFCM 43  
system console 5  
1403 Model N1 88  
1403 Models 2 and 5 73  
1442 60  
2501 69  
3340 131  
3344 131  
3410/3411 112

KP (see KEEP)

label writing, tape 197

LAMP TEST key, 5415 6

last card procedures

MFCM 44  
1442 61  
2501 69

lateral print adjustment lever

1403 Model N1 93  
1403 Models 2 and 5 77

lateral print vernier knob

1403 Model N1 93  
1403 Models 2 and 5 77

LC print chain image 258

LCA ATTN light, 5415 11

LCA panel switches, 5415 12

LCA panel, 5415 4, 11

LCA STEP key, 5415 13

library maintenance program (\$MAINT)

operating procedures 243  
summary 238

lights

system console 5  
1403 Model N1 89  
1403 Models 2 and 5 72  
1442 60,61  
2501 68  
3340 131  
3344 131  
3410/3411 112  
5445 126

limiting job priorities 174

line feed selector lever, 3284 105

list program operating procedures 247

LOAD key (see PROGRAM LOAD key)

LOAD OCL statement

parameters 225  
summary 218

load point marker 113

LOAD REWIND key, 3410/3411 112

loading, data module 132

local communications adapter (see LCA)

LOCK/SHIFT keys, 3277 18

**LOG OCL statement**  
     parameters 226  
     summary 218  
 log sheets, error 201  
 logging, transaction 197  
 logout, device counter 234  
 lower cover key, 1403 Model N1 88  
**LS (low-speed) START light**  
     1403 Model N1 90  
     1403 Models 2 and 5 73  
**LS (low-speed) STOP light**  
     1403 Model N1 90  
     1403 Models 2 and 5 73  
**LSR DISPLAY SELECTOR switch, 5415 13**

**MACHINE CHECK light, MFCM 42**  
**MACHINE CYCLE lights, 5415 6**  
 machine safety vii  
 magnetic tape (see tape, 3410/3411)  
 main data area names display 159  
 main register display 6  
 main storage dump command 171  
 main storage size, changing 154  
 main storage, dumping 205  
 manual call/answer 233  
 manual controls  
     1403 Model N1 90  
     1403 Models 2 and 5 74  
 marker, load point 113  
 master-card gangpunching procedures,  
     interspersed 251  
 match field gangpunching 252  
**MEM parameter, IMAGE OCL statement 258**  
**message**  
     deletion 176  
     display unit 5  
     response 200  
     retention 179  
     scanning 200  
 messages, error 261  
 meter (see usage meter)  
**MFCM**  
     (see also 2560)  
     card path 44  
     input device assignment 182  
**MFCU**  
     (see also 5424)  
     card paths 29  
     input device assignment 182  
**MLTERFIL (terminal statistics) table 234**  
**mode**  
     job and step 210  
     selector switch 13  
 mode change, processing 178

**MODE 1/2 printer switch, 3284 104**  
**Model 10 programming support 263**  
**Model 15A error log sheet 201**  
**Model 15B error log sheet 202**  
**Model 15C-D error log sheet 203**  
**mounting**  
     data module 132  
     2316 disk pack 129  
     5440 disk cartridge 121  
**MSAR display selection 12**  
**MSG NOT RSP nn message 26**  
 multi-function card machine (see MFCM,  
     2560)  
 multi-function card unit (see MFCU, 5424)  
**multiprogramming**  
     operating procedures 211  
     system date considerations 212

**N (names) operand, DISPLAY command 162**  
**name parameter, IMAGE OCL statement 258**  
**names display, area 159**  
**networks**  
     nonswitched 232  
     switched 233  
**new line key, 3277 18**  
**NEW operand, START command 192**  
**NHT (see NOHALT)**  
**NI (see NODELETE)**  
**NOHALT command**  
     description 178  
     summary 270.1  
**NOHALT OCL statement**  
     override 173  
     parameters 226  
     summary 218  
**NODELETE command**  
     description 179  
     summary 271  
 non-process runout (see NPRO)  
 nonspooled operating procedures 211  
 nonswitched networks 232  
**NPRO (non-process runout) key**  
     MFCM 43  
     MFCU 28  
     1442 60  
     2501 69  
**NPRO (non-process runout) light, MFCU 28**  
 number of output copies, changing 153  
**number operand**  
     CHANGE copies command 153  
     RESTART command 184.1  
**number parameter, IMAGE OCL statement 257**



- object program execution 230
- OCC (operator control commands)
  - conventions 147
  - definition 146
  - entry 146
  - functions 146
  - summary 267
- OCL (operation control language)
  - overview 215
  - statement parameters 221
- OFF operand
  - SIMULATE command 189
  - TLOG command 197
- ON operand
  - SIMULATE command 189
  - TLOG command 197
- OPEN lights, 5415 disk panel 9
- operating procedures
  - card utilities 244
  - copy/dump 239
  - disk sort 243
  - dump/restore 239
  - library maintenance 243
  - list program 247
  - Model 10 programming support 263
  - multiprogramming 210
  - reproduct/interpret program 248
  - sort/collate program 244
  - system service programs 239
  - tape sort 243
- operation
  - nonspooled 210
  - program 213
  - spooled 210
  - system 135
- operation control language (see OCL)
- operator control commands (see OCC)
- operator keyboard (3277) 17
- operator panel
  - MFCU 28
  - 1403 Model N1 89
  - 1403 Models 2 and 5 72
  - 1442 60
  - 2501 68
  - 3284 104
  - 3340 131, 133
  - 3344 131
  - 3410/3411 112
  - 5445 126
- option operand, DUMP command 205
- output copies, changing number of 153
- output, restarting 184.1
- override
  - file share area size 188
  - NOHALT OCL 173
  - partition size 188
- OVERRUN light, 1442 61
- overview, system operating procedures 141

- P (see PCH, STOP)
- PAGE operand
  - RESTART command 184.1
  - STOP command 195
- panel
  - CE 12
  - MFCM 42
  - MFCU 28
  - processing unit display 6
  - system console control 4
  - 1403 Model N1 89
  - 1403 Models 2 and 5 70
  - 1442 60
- paper advance knob
  - 1403 Model N1 91
  - 1403 Models 2 and 5 75
  - 3284 104
- PARITY CHECK switch, 5415 13
- partition
  - assignment, changing 156
  - input device, changing 182
  - priority, changing 180
  - program execution, starting 190
  - program execution, stopping 194
  - size, overriding/changing 188
- PAUSE OCL statement summary 219
- PA1 key, 3277 21
- PA2 key, 3277 23
- PCH operand
  - RESTART command 184.1
  - START command 192
  - STOP command 195
- PCHQ operand
  - CANCEL command 150
  - CHANGE card type command 152
  - CHANGE copies command 153
  - CHANGE priority command 157
  - DISPLAY command 168.1
  - HOLD command 174.1
  - KEEP command 177
  - RELEASE command 183
  - REUSE command 186
- PF keys, 3277 23
- PF10 key for OCC 146
- PG (see PAGE)
- platen removal, MFCM 52
- PN print chain image 259
- positioning keys, 3277 19
- postprint position card removal, MFCM 54
- power check indicator light, 5415 6
- power check light, 5415 208
- power off, emergency 7
- POWER ON light
  - MFCM 43
  - 1403 Model N1 89
  - 1442 60
  - 2501 69
  - 5445 126
- power on procedures
  - 1442 61
  - 2501 69
  - 3284 105

**POWER switch**  
 3277 16  
 3284 104  
 3340/3344 132  
 5415 5  
 5445 126  
 power, stopping/restoring system 208  
 preprint position card removal, MFCM 51  
 PRI (primary hopper) light, MFCU 28  
 PRIMARY HOPPER CHECK light, MFCM 42,46  
 primary hopper input device  
   assignment 182  
 primary input station card removal,  
   MFCM 47  
 primary preread station card removal,  
   MFCM 47  
 PRIMARY READY light  
   MFCM 43  
   MFCU 28  
 print adjustment knobs/levers, 1403 Model  
   N1 92  
 print chain cartridge, 1403  
   Models 2 and 5 82  
 print chain images 258  
 PRINT CHECK light  
   1403 Model N1 89  
   1403 Models 2 and 5 72  
 print density adjustments  
   1403 Model N1 102  
   1403 Models 2 and 5 85  
 print density control knob, 1403  
   Model N1 95  
 print density lever, 1403  
   Models 2 and 5 78  
 print head setting, MFCM 57  
 print-line indicator  
   1403 Model N1 92  
   1403 Models 2 and 5 76  
 print output, restarting 184.1  
 print program (\$CPRNT) 277  
 print quality control  
   1403 Model N1 102  
   1403 Models 2 and 5 85  
 print queue  
   canceling 148  
   display example 170  
   displaying 159  
 PRINT READY light  
   1403 Model N1 89  
   1403 Models 2 and 5 72  
 print ribbon changing  
   MFCM 56  
   MFCU 34  
   1403 Model N1 99  
   1403 Models 2 and 5 81  
   3284 108  
 print station card removal, MFCM 51  
 print timing dial, 1403 Models 2 and 5 79  
 print train cartridge, 1403 Model N1 100  
 print unit card removal, MFCU 32  
 print-unit release lever, 1403  
   Models 2 and 5 75  
 print writer (spool)  
   changing priority 180  
   starting 190  
   stopping 194  
 printer (see also 1403, 3284)  
 printer control keys  
   1403 Model N1 88  
   1403 Models 2 and 5 73  
 PRINTER OCL statement  
   parameters 226  
   summary 219  
 printer ribbon changing  
   (see also print ribbon)  
   1403 Model N1 99  
   1403 Models 2 and 5 81  
   3284 108  
 PRINTER switches, 3284 104  
 printing, display screen contents 25  
 printing, restarting 184.1  
 priorities, limiting job 174  
 priority change 157, 180  
 problem determination 261  
 procedures  
   (see also operating procedures)  
   cancel 204  
   multiprogramming 211  
   1442 61  
   2501 69  
 processing mode change 178  
 processing mode selector switch, CE control  
   panel 13  
 processing unit display panel 6  
 processing unit display panel, 5415 4  
 processing, stopping 173  
 PROCESSOR CHECK light, 5415 5  
 processor checks 262  
 program access key, 3277 21  
 program cancel 148  
 program checks 261  
 program execution (see execution, program)  
 program function (PF) keys, 3277 23  
 program interruption, rollout-evoking 187  
 PROGRAM LOAD key, 5415 5  
 PROGRAM LOAD SELECTOR switch, 5415 8  
 program load, initial (see IPL)  
 program operation 213  
 program operation termination 199  
 program run sheet  
   sample viii  
   use of vii  
 program temporary fixes (PTFs) 265  
 programmable work station input device  
   assignment 182  
 prompts, displaying 26  
 prompts, 3277 25  
 PRT operand  
   RESTART command 184.1  
   START command 192  
   STOP command 194

- PRTQ operand
  - CANCEL command 149
  - CHANGE copies command 153
  - CHANGE forms type command 155
  - CHANGE priority command 157
  - DISPLAY command 168.1
  - HOLD command 174.1
  - KEEP command 177
  - RELEASE command 183
  - REUSE command 186
- PTFs (program temporary fixes) 265
- PTN operand, CHANGE partition command 156
- PTSHA entry 25
- PTY command
  - description 180
  - summary 271
- PTY operand, CHANGE priority command 157
- punch (see also MFCM, MFCU, 1442, 2560, 5424)
- PUNCH CHECK light, MFCM 43
- PUNCH light, 1442 61
- PUNCH OCL statement
  - parameters 227
  - summary 219
- punch output, restarting 184.1
- punch priority, changing 180
- punch queue
  - canceling 148
  - display example 170.2
  - displaying 159
- PUNCH STA (station) light, 1442 61
- punch station card removal, MFCM 49
- punch unit card removal, MFCU 31
- punch writer (spool)
  - changing priority 180
  - starting 190
  - stopping 194
- PWR CHK (power check) light, 5415 6
  - description 6
  - procedures 208
- P1 operand
  - CANCEL command 150, 205
  - DISPLAY command 162
  - DUMP command 171, 205
  - HALT command 173
  - NOHALT command 178
  - PTY command 180
  - READER command 182
  - SET command 188
  - START command 191
  - STOP command 195
- P1403 entry 25
- P2 operand
  - CANCEL command 150, 205
  - DISPLAY command 162
  - DUMP command 171, 205
  - HALT command 173
  - NOHALT command 178
  - PTY command 180
  - READER command 182
  - SET command 188
  - START command 191
  - STOP command 195
- P3 operand
  - CANCEL command 150, 205
  - DISPLAY command 162
  - DUMP command 171, 205
  - HALT command 173
  - NOHALT command 178
  - PTY command 180
  - READER command 182
  - SET command 188
  - START command 191
  - STOP command 195
- P3284 entry 25
- quality control, 1403 print 85
- queue
  - canceling 148
  - display example 168.2
  - displaying 159
  - keeping job/jobstep on 177
  - releasing 183
- R (see RDR, RELEASE)
- R/W (read/write) switch, 3344 132
- raise cover key, 1403 Model N1 88
- RATE SELECT switch, 5415 10
- RD (ready check) light, MFCU 28
- RDR operand
  - START command 192
  - STOP command 194
- RDRQ operand
  - CANCEL command 149
  - CHANGE core command 154
  - CHANGE partition command 156
  - CHANGE priority command 157
  - DISPLAY command 168.1
  - HOLD command 174.1
  - KEEP command 177
  - RELEASE command 183
- READ CHECK light
  - MFCM 43
  - 2501 68
- read only function, 3340 134
- READ ONLY indicator light, 3340 131
- READ REG (register) light, 1442 61
- READ STA (station) light, 1442 61
- read station card removal, MFCM 48
- READ switch, 3344 132
- reader (see also 2501)
- reader (spool)
  - changing priority 180
  - starting 190
  - stopping 194
- READER command
  - description 182
  - summary 271
- READER OCL statement
  - parameters 227
  - summary 219
- reader queue
  - canceling 148
  - display example 169
  - displaying 159

**READY light**  
 1442 60  
 2501 68  
 3340 131  
 3344 131  
 3410/3411 112  
 5415 9  
 5445 126  
**ready procedures**  
 1442 61  
 2501 69  
**READY prompt** 26  
**reassign alternate track program (\$RSALT)**  
 summary 238.1  
**RECEIVE INITIAL light, 5415**  
 BSCA panel 10  
 LCA panel 12  
**RECEIVE MODE light, 5415**  
 BSCA panel 10  
 LCA panel 11  
**RECEIVE TRIGGER light, 5415**  
 BSCA panel 10  
 LCA panel 11  
**recover index program (\$RINDX)**  
 summary 238.1  
**reel, tape**  
 mounting 113  
 removal 113  
**reformat data card** 249  
**register display unit** 6  
 description 6  
 use of 200  
**release button, 5440 disk cartridge** 121  
**RELEASE command**  
 description 183  
 summary 271  
**release lever, 1403 print unit** 91  
**removal**  
 data module 33, 133  
 information message 176  
 2316 disk pack 127  
 5440 disk cartridge 118  
**reproduce/interpret program operating**  
 procedures 248  
**RESET key**  
 3277 21  
 3410/3411 112  
**reset keys, CE control panel** 13  
**reset switch, 3340/3344** 132  
**response, system message** 200  
**restart/checkpoint (see checkpoint/restart)**  
**RESTART command**  
 description 184.1  
 summary 271  
**restore carriage key, 1403 Model N1** 88  
**REUSE command**  
 description 186  
 summary 271  
**rewind, tape** 197  
**ribbon changing**  
 1403 Model N1 99  
 1403 Models 2 and 5 81  
 3284 108  
**ribbon shield**  
 1403 Model N1 92  
 1403 Models 2 and 5 76  
**right-hand tractor vernier knob**  
 1403 Model N1 93  
 1403 Models 2 and 5 78  
**RO (see ROLLOUT)**  
**ROLL operand, START command** 192  
**ROLLOUT command**  
 description 187  
 summary 271  
**rollout/rollin function** 230  
**rollout with spooling** 232  
**RPG II inquiry program** 230  
**RPG II telecommunications program** 232  
**RQ (see RDRQ)**  
**RU (see REUSE)**  
**RUN OCL statement summary** 220  
**run sheet (see program run sheet)**  
**R2 support on 3340** 189  
  
**S (see START)**  
**safety, machine** vii  
**sample dump output** 206.1  
**SAR (storage address register) DISPLAY**  
 switch 12  
**scanning, system message** 200  
**screen formats** 24  
**screen, CRT** 16  
**SEC (secondary hopper) light, MFCU** 28  
**SECONDARY HOPPER CHECK light, MFCM** 42,46  
**secondary hopper input device**  
 assignment 182  
**secondary preread station card removal**  
 MFCM 48  
**SECONDARY READY light**  
 MFCM 43  
 MFCU 28

**select display switch, 5415**  
  BSCA panel 10  
  LCA panel 12  
**SELECT light, 3410/3411 112**  
**SELECT LOCK light, 5445 126**  
**select transmission rate switch, 5415 BSCA**  
  panel 10  
**selector switches, CE control panel 13**  
**sense lights, 1442 61**  
**service programs 238**  
**SET command**  
  description 188  
  summary 271  
**SH operand, SET command 188**  
**SHA (see also system history area)**  
**SHA full message 178**  
**SHA operand**  
  **HALT command 173**  
  **NOHALT command 178**  
**SHIFT INLK (interlock) light**  
  1403 Model N1 90  
  1403 Models 2 and 5 73  
**SHIFT/LOCK keys, 3277 18**  
**SIMULATE command**  
  description 189  
  summary 271  
**simulation area names display 159**  
**simulation area program (\$SCOPY)**  
  summary 238.1  
**SINGLE CYCLE key**  
  1403 Model N1 88  
  1403 Models 2 and 5 73  
**size operand**  
  **CHANGE core command 154**  
  **SET command 188**  
  **START command 192**  
**size override/change**  
  file share area 188  
  partition 188  
**slide bars, tractor**  
  1403 Model N1 94  
  1403 Models 2 and 5 77  
**SM (see SIMULATE)**  
**sort/collate program operating**  
  procedures 244  
**sort programs operating procedures 243**  
**SP (see SPOOL)**  
**space bar, 3277 18**  
**space carriage key, 1403 Model N1 88**  
**space, freeing in spool file 186**  
**special punch station procedures, MFCM 50**  
**spool file copy program (\$QCOPY)**  
  summary 238  
**spool file space, freeing 186**  
**SPOOL operand**  
  **CANCEL command 149**  
  **PTY command 180**  
  **START command 191**  
  **STOP command 194**  
**spooling**  
  canceling 148  
  changing priority 180  
  operating procedures 212  
  rollout with 232  
  starting 190  
  stopping 194  
**stacker area card removal**  
  MFCM 55  
  MFCU 33  
**stacking, forms**  
  1403 Model N1 98  
  1403 Models 2 and 5 81  
**stand-alone programs, IPL for 140**  
**START command**  
  description 190  
  summary 272  
**START key**  
  MFCM 43  
  MFCU 28  
  system console (5415) 5  
  1403 Model N1 88  
  1403 Models 2 and 5 73  
  1442 60  
  2501 69  
  3410/3411 112  
**START PRINT switch, 3284 104**  
**START/STOP switch**  
  disk panel, 5415 8,9  
  3340 131  
  3344 131  
  5445 126  
**status display 159**  
**status indicators, system 6**  
**status lights, 1442 60**  
**status line, 3277 26**  
**STATUS operand, DISPLAY command 159**  
**step (job) cancel 148**  
**step mode 210**  
**step mode cancel considerations 204**  
**STEP operand, STOP command 195**  
**step release 183**  
**stepname operand**  
  **CANCEL command 150**  
  **CHANGE card type command 152**  
  **CHANGE copies command 153**  
  **CHANGE forms type command 155**  
  **CHANGE priority command 157**  
  **HOLD command 174.1**  
  **KEEP command 177**  
  **RELEASE command 183**  
  **REUSE command 186**  
**STKR (stacker full) light, MFCU 28**  
**stop carriage key, 1403 Model N1 88**  
**STOP command**  
  description 194  
  summary 273

**STOP key**  
 MFCM 43  
 MFCU 28  
 system control panel (5415) 5  
 1403 Model N1 88  
 1403 Models 2 and 5 73  
 1442 60  
 2501 69  
**STOP switch**  
 3340 131  
 3344 131  
 5445 126  
 stopping, job processing 173  
 storage address register switch 12  
 storage dump command 171  
 storage size, changing 154  
 STORAGE TEST switch, 5415 13  
 storage, dumping 205  
 string switch feature, 3340/3344 132  
**SWITCH OCL statement**  
 parameters 227  
 summary 220  
 switched networks 233  
**switches**  
 BSCA panel 10  
 CE control panel 12  
 disk panel 8  
 LCA panel 12  
 system console 5  
 3284 104  
 3340 131  
 3344 131  
**SYNC (synchronization) CHECK light**  
 1403 Model N1 89  
 1403 Models 2 and 5 73  
 syntax, OCC 147  
**SYSTEM AVAILABLE indicator light, 3277 24**  
 system configuration record print 277  
 system console, 5415 4  
 system control panel 5  
 system date  
 considerations, multiprogramming 212  
 entering 139  
 setting 158.1  
 system format, screen 25  
 system history area (SHA)  
 display 159  
 display program (\$HIST) summary 238  
 PTSHA entry 25  
 system history area copy program (\$HACCP)  
 summary 238  
 system history area copy program (see  
 \$HACCP)  
 system input device  
 changing 182  
 considerations 211  
 system message response/scanning 200  
**SYSTEM operand, DUMP command 172, 205**  
 system operation  
 general 132  
 procedures summary 141  
 termination 199  
 system power, restoring/stopping 208  
**SYSTEM RESET key, 5415 13**  
 system service programs  
 operating procedures 239  
 summary descriptions 238  
 system status display 159  
 system time, setting 196  
 System/3 Model 15 error log sheets 201  
  
**T (see RESTART)**  
 tab keys, 3277 19  
 tape considerations 241  
 tape control keys 112  
 tape error summary program (\$TVES)  
 summary 239  
 tape handling 115  
 tape head cleaning 114  
 TAPE INDICATE light, 3410/3411 112  
 tape initialization program (\$TINIT)  
 summary 238.1  
 tape labels, writing 197  
 tape length 241  
 tape markers 113  
 tape reel  
 mounting 113  
 removal 113  
 tape rewind 197  
 tape sort program operating  
 procedures 243  
 tape subsystem (see 3410/3411) 104  
 task history display 159  
 task operand, DISPLAY command 168  
 task priority change 180  
 telecommunications program execution 232  
**TERMINAL STATISTICS TABLE (MLTERFIL) EMPTY**  
 message 234  
**TERMINAL STATISTICS TABLE (MLTERFIL) NOT**  
 FOUND message 234  
 termination, system/program operation 199  
**TEST MODE light, 5415**  
 BSCA panel 9  
 LCA panel 11  
**TEST REQ key, 3277 21**  
 test storage switch, CE control panel 13  
 TEST switch, 3284 104  
 TH CHK (thermal check) light, 5415 6, 208  
 THE SHA IS FULL message 173  
 THER INLK (thermal interlock) light  
 1403 Model N1 90  
 1403 Models 2 and 5 73