

**IBM System/3  
RPG II Additional Topics  
Programmer's Guide**

**Program Numbers:**

5702-RG1 (Model 10)  
5704-RG1 (Model 15)  
5704-RG2 (Model 15)  
5705-RG1 (Model 12)







**IBM System/3  
RPG II Additional Topics  
Programmer's Guide**

**Program Numbers:**

**5702-RG1 (Model 10)**

**5704-RG1 (Model 15)**

**5704-RG2 (Model 15)**

**5705-RG1 (Model 12)**



### Third Edition (July 1974)

This is a major revision of, and obsoletes, GC21-7567-1. Information concerning IBM System/3 Model 15 has been added and numerous corrections have been made. Changes to text and illustrations are indicated by a vertical line to the left of the change; new or extensively revised illustrations are denoted by the symbol ● at the left of the caption.

This edition applies to the following IBM System/3 RPG II program products:

Version	Modification	Program Number	System/3 Model
15	00	5702-RG1	8 and 10 Disk
6	00	5704-RG1	15A, B, C
2	00	5704-RG2	15D
4	00	5705-RG1	12

Changes are periodically made to the information herein; before using this publication in connection with the operation of IBM systems, refer to the latest *IBM System/3 Bibliography*, GC20-8080, for the editions that are applicable and current.

This publication contains examples of data and reports used in daily business operations. To illustrate them as completely as possible, the examples include the names of individuals, companies, brands, and products. All of these names are fictitious and any similarity to the names and addresses used by an actual business enterprise is entirely coincidental.

Use this publication only for the purposes stated in the *Preface*.

Publications are not stocked at the address below. Requests for copies of IBM publications and for technical information about the system should be made to your IBM representative or to the IBM branch office serving your locality.

This publication could contain technical inaccuracies or typographical errors. Use the Reader's Comment Form at the back of this publication to make comments about this publication. If the form has been removed, address your comments to IBM Corporation, Publications, Department 245, Rochester, Minnesota 55901. Comments become the property of IBM.



This manual presents advanced RPG II programming topics for application programmers and students, who must code programs for IBM System/3:

- Model 6
- Model 8
- Model 10 (Card System)
- Model 10
- Model 12
- Model 15

The System/3 Model 8 is supported by System/3 Model 10 control programming and program products. The facilities described in this publication for the Model 10 are also applicable to the Model 8, although the Model 8 is not referred to. Note that not all devices and features that are available on the Model 10, are available on the Model 8. Therefore, Model 8 users should be familiar with the contents of the *IBM System/3 Model 8 Introduction*, GC21-5144.

#### PREREQUISITES

This manual assumes that you have coded and tested some basic RPG II programs that include listing records on a printer, simple calculations, group totals, and the use of more than one record type. You may have gained this experience through IBM education courses, programmed instruction courses, or previous data processing experience. *Introduction to RPG II*, GC21-7514, contains some of this basic information.

#### ORGANIZATION OF THE MANUAL

This publication has eleven chapters. Chapters 1-6 cover information that is basic to most data processing jobs: RPG II program logic, detailed information about writing input, output, and calculation specifications and the concepts and specifications involved in multifile processing. Additional programming topics that you may require for your job are presented in Chapters 7-11: controlling input and output during calculation time, tables, arrays, data structure, and the DEBUG operation.

#### RELATED PUBLICATIONS

There are numerous IBM System/3 publications containing further information on RPG II. The following are the related reference manuals:

- *IBM System/3 Card System RPG II Reference Manual*, SC21-7500
- *IBM System/3 RPG II Reference Manual*, SC21-7504 (Model 10, Model 12 and Model 15)
- *IBM System/3 Model 6 RPG II Reference Manual*, SC21-7517

If you are programming on a disk system, it would be helpful if you would understand the disk concepts and disk file processing information in the following books before reading this book:

- *IBM System/3 Disk Concepts and Planning Guide*, GC21-7571
- *IBM System/3 RPG II Disk File Processing Programmer's Guide*, GC21-7566







This publication is a *programmer's guide*; it is not intended to serve the same purpose as a reference manual of language specifications and does not replace a reference manual.

RPG II programming topics are approached and organized according to their normal use in a data processing job, using examples whenever possible. Unlike a reference manual, individual chapters are self-contained units of information, intended to be read from beginning to end. However, if you desire information about a specific topic, you may go directly to that topic by using the index or the table of contents. If an individual chapter has a special prerequisite topic, that topic is clearly identified on the title page of the chapter.

Although the chapters are complete units, there is a logical progression of topics through chapters 1-6. Therefore, you may wish to read them consecutively. If you have read the *RPG II Programming Fundamentals* Programmed Instruction course, you do not need to read chapters 1-6 consecutively.

For ease of illustration, many of the examples in this book use card-like figures to represent records. This does not imply that a card device must be used for input or output in these situations. Any of several input/output devices might be used, depending on which System/3 model and configuration you are using.

### Review Questions

Review questions and answers are provided at the end of each chapter. Where chapters contain several related topics, these questions are grouped by subtopic. If you wish, you may turn to the end of the chapter after you complete each subtopic, to answer the review questions and reinforce what you have learned, before continuing the chapter.





## Contents

<b>HOW TO USE THE MANUAL</b> . . . . .	iii	<b>CHAPTER 3. CONTROLLING PRINTER OUTPUT</b> . . . . .	3-1
<b>CHAPTER 1. RPG II LOGIC</b> . . . . .	1-1	Introduction . . . . .	3-2
Introduction . . . . .	1-2	Using Overflow and Fetch Overflow To Control Page Formatting . . . . .	3-2
Basic Data Processing Logic . . . . .	1-2	Overflow Indicators . . . . .	3-2
Basic RPG II Logic . . . . .	1-4	Specifications for Using Overflow Indicators . . . . .	3-4
Specific Steps in Basic RPG II Logic . . . . .	1-6	Preventing Records From Printing Over The Perforation . . . . .	3-6
First Program Cycle . . . . .	1-7	Fetch Overflow . . . . .	3-8
Summary of Basic RPG II Logic . . . . .	1-7	Aligning Forms . . . . .	3-12
RPG II Logic Related To Indicators . . . . .	1-7	Editing . . . . .	3-12
1P (First Page) Indicators . . . . .	1-13	Methods of Editing . . . . .	3-12
Last Record Indicator (LR) . . . . .	1-16	Editing and End Position . . . . .	3-19
Record Identifying Indicators (01-99) . . . . .	1-19	Using *PLACE To Print Duplicate Information . . . . .	3-19
Field Indicators (01-99) . . . . .	1-25	Specifications For Using *PLACE . . . . .	3-22
Resulting Indicators (01-99) . . . . .	1-31	Formation Of Print Lines . . . . .	3-22
Halt Indicators (H1-H9) . . . . .	1-35	Printing A Field Several Times On The Same Line . . . . .	3-26
Overflow Indicator (OA-OG, OV) . . . . .	1-41	Using Two Printer Output Files in One Program . . . . .	3-27
Matching Records Indicator (MR) . . . . .	1-42	Model 10 Card and Disk Systems . . . . .	3-28
Setting Indicators . . . . .	1-43	Model 6 . . . . .	3-28
<b>REVIEW 1</b> . . . . .	1-45	File Description Specifications . . . . .	3-28
<b>ANSWERS TO REVIEW 1</b> . . . . .	1-46	Output Format Specifications . . . . .	3-29
<b>CHAPTER 2. DESCRIBING AND USING INPUT</b> . . . . .	2-1	Example: End-of-the-Month Billing . . . . .	3-31
Introduction . . . . .	2-2	<b>REVIEW 3</b> . . . . .	3-33
Control Fields . . . . .	2-2	Overflow and Fetch Overflow . . . . .	3-33
Split Control Fields . . . . .	2-5	Forms Alignment . . . . .	3-34
Checking the Sequence of Record Types . . . . .	2-6	Editing . . . . .	3-34
Order of Record Types Within a Group . . . . .	2-6	*PLACE . . . . .	3-35
Checking the Order of Record Types in a Group . . . . .	2-12	Dual Printer Output Files . . . . .	3-35
Incorrect Records Within a Group . . . . .	2-12	<b>ANSWERS TO REVIEW 3</b> . . . . .	3-36
Sequenced and Unsequenced Record Types in a Group . . . . .	2-14	<b>CHAPTER 4. CARD OUTPUT OPERATIONS</b> . . . . .	4-1
Unexpected or Unused Records Within a Group . . . . .	2-14	Introduction . . . . .	4-2
Field Record Relation Indicators . . . . .	2-15	Punching And Printing On Cards . . . . .	4-2
OR Relationship . . . . .	2-15	Punched Output . . . . .	4-2
OR Relationship With Field Record Relation Entries . . . . .	2-16	Printing On Cards . . . . .	4-2
Field Record Relation with Control Fields . . . . .	2-18	Using One File For Both Input And Output . . . . .	4-8
Field Record Relation with Split Control Fields . . . . .	2-18	Punching Into The Same Card That Is Read . . . . .	4-8
Conditioning Use of Input Files (External Indicators) . . . . .	2-19	Punching Into A Blank Card In The File . . . . .	4-11
Using One Program to do More Than One Job . . . . .	2-19	When To Specify A Combined File . . . . .	4-14
Ending The Program Before Processing All Files Completely . . . . .	2-22	Stacker Selection . . . . .	4-14
<b>REVIEW 2</b> . . . . .	2-25	Input And Combined File Cards . . . . .	4-15
<b>ANSWERS TO REVIEW 2</b> . . . . .	2-28	Stacker Selecting Output File Cards . . . . .	4-17
<b>CHAPTER 3. CONTROLLING PRINTER OUTPUT</b> . . . . .	3-1	Merging Input And Output File Cards . . . . .	4-19
Introduction . . . . .	3-2	<b>REVIEW 4</b> . . . . .	4-21
Using Overflow and Fetch Overflow To Control Page Formatting . . . . .	3-2	Punching and Printing On Cards . . . . .	4-21
Overflow Indicators . . . . .	3-2	Using One File For Both Input And Output . . . . .	4-21
Specifications for Using Overflow Indicators . . . . .	3-4	Stacker Selection . . . . .	4-23
Preventing Records From Printing Over The Perforation . . . . .	3-6	<b>ANSWERS TO REVIEW 4</b> . . . . .	4-25
Fetch Overflow . . . . .	3-8		
Aligning Forms . . . . .	3-12		
Editing . . . . .	3-12		
Methods of Editing . . . . .	3-12		
Editing and End Position . . . . .	3-19		
Using *PLACE To Print Duplicate Information . . . . .	3-19		
Specifications For Using *PLACE . . . . .	3-22		
Formation Of Print Lines . . . . .	3-22		
Printing A Field Several Times On The Same Line . . . . .	3-26		
Using Two Printer Output Files in One Program . . . . .	3-27		
Model 10 Card and Disk Systems . . . . .	3-28		
Model 6 . . . . .	3-28		
File Description Specifications . . . . .	3-28		
Output Format Specifications . . . . .	3-29		
Example: End-of-the-Month Billing . . . . .	3-31		

<b>CHAPTER 5. CONTROLLING OPERATIONS IN AN RPG II PROGRAM</b>	<b>5-1</b>
Introduction	5-2
Additional Uses of Indicators To Control Calculations and Output	5-2
Preventing Operations From Being Done When An Error Occurs	5-2
Controlling Which Operations Are Done for a Specific Program Run	5-7
Controlling Calculations When Overflow Occurs	5-11
Performing Calculations On The Basis of the Results Of Other Calculations	5-12
Controlling Operations on the Basis of the Next Record In A File	5-17
Processing Card or Disk Files	5-17
Checking For Duplicates	5-20
Doing Special Operations When There Is Only One Record In A Group	5-26
Doing Special Operations For The Last Record In A Group	5-28
Additional Points To Consider About Look Ahead	5-28
Moving Data	5-28
Specifications For Moving Data	5-29
Saving Information From A Field By Move Operations	5-31
Separating One Field Into Two Parts	5-33
Changing Field Type (Alphameric or Numeric)	5-34
Branching In Calculations	5-36
Bypassing Calculations	5-36
Branching Backward	5-42
Using Subroutines in Calculations	5-44
Using Subroutines To Do The Same Calculations Several Times in One Cycle	5-45
Controlling Overlay by Using Subroutines	5-54
RPG II Linkage Editor	5-54
Linkage Editor Map	5-55
Simple Overlays	5-56
Special Open	5-56.1
Overlay Starting Addresses	5-56.1
Fitting Available Storage	5-56.3
RPG II Logic and Function Shifting	5-56.3
Special Uses of Control Level Indicators	5-56.4
Internal Control Level Indicator LO	5-56.4
Using Control Level Indicators As Calculation Conditioning Indicators	5-59
Group Printing	5-59
Binary Field Operations (Controlling Switches)	5-67
BITON Operation Code	5-67
BITOF Operation Code	5-67
TESTB Operation Code	5-68
Example	5-69
Increasing The Speed of Operations (Dual I/O Areas)	5-69
Dual Input Areas	5-69
Dual Output Areas	5-71

<b>REVIEW 5</b>	<b>5-73</b>
Additional Uses Of Indicators	5-73
Controlling Operations On The Basis of the Next Record In A File	5-74
Moving Data	5-74
Branching In Calculations	5-75
Using Subroutines In Calculations	5-75
Special Uses Of Control Level Indicators	5-76
Binary Field Operations	5-76
Dual Input/Output Areas	5-76

<b>ANSWERS TO REVIEW 5</b>	<b>5-77</b>
----------------------------	-------------

<b>CHAPTER 6. MATCH FIELDS AND MULTIFILE PROCESSING</b>	<b>6-1</b>
Introduction	6-2
Checking Sequence Of Records Within A File	6-2
File Containing Only One Record Type	6-2
File Containing More Than One Record Type	6-6
Using Match Fields With Field-Record Relation for More Than One Record Type in a File	6-8
Match Fields The Same For All Record Types	6-8
Match Fields Differ Between Record Types	6-9
Matching Records: One Record Type in Each File	6-12
Processing Order: More Than One Matching Record In A Secondary File	6-12
Processing Order: More Than One Matching Record In The Primary File	6-20
Matching Records: Records Which Have No Match In The Other File	6-20
Matching Records: More Than One Record Type In A File	6-26
Match Fields In Different Locations In The Same File	6-26
Processing Records Which Do Not Have Match Fields	6-29
Matching Records: When All Records In One File Have Been Processed	6-30
Use of Match Fields and Control Fields In the Same File	6-34
Determining Whether Files Should Be Primary or Secondary	6-38

<b>REVIEW 6</b>	<b>6-41</b>
Review Problem	6-44

<b>ANSWERS TO REVIEW 6</b>	<b>6-46</b>
Solution To The Review Problem	6-49

**CHAPTER 7. PROGRAMMED CONTROL OF INPUT AND OUTPUT . . . . . 7-1**  
 Introduction . . . . . 7-2  
 Altering The Order of Processing Files (Force Operation) . . . . . 7-2  
     Specifying The Next File To Process . . . . . 7-2  
     Alternating Processing Between Two Files . . . . . 7-4  
     Forcing A Number of Records From a File . . . . . 7-7  
     Look-Ahead To Determine Whether A File Is To Be Forced . . . . . 7-15  
 Processing Demand Files (Read Operation) . . . . . 7-22  
     Considerations For Using READ and Demand Files . . . . . 7-26  
 Repetitive Output (Except Operation) . . . . . 7-26  
     Using EXCPT and \*PLACE . . . . . 7-26  
     Conditioning The Use of EXCPT Operation . . . . . 7-29

**REVIEW 7 . . . . . 7-31**  
 FORCE . . . . . 7-31  
 READ . . . . . 7-32  
 EXCPT . . . . . 7-33

**ANSWERS TO REVIEW 7 . . . . . 7-34**

**CHAPTER 8. TABLES . . . . . 8-1**  
 Introduction . . . . . 8-2  
     Searching a Single Table . . . . . 8-4  
     Designing Table Input Records . . . . . 8-4  
     Describing Table Input Records With Extension Specifications . . . . . 8-5  
     Coding The Table Lookup Operation (LOKUP) . . . . . 8-7  
 Two Table Search . . . . . 8-8  
     Designing Table Input Records For Two Tables . . . . . 8-11  
     Describing Two Tables With Extension Specifications . . . . . 8-13  
     Coding The Table Lookup Operation (LOKUP) . . . . . 8-14  
 Using Table Data In Calculations and Output . . . . . 8-14  
     Conditioning Operations On The Basis of a Table Lookup . . . . . 8-14  
     Referencing Data Following A Successful Search . . . . . 8-16  
     Searching For Low, High, or Equal Conditions . . . . . 8-19  
     Moving Data In A Table Entry . . . . . 8-21  
     Modifying The Contents Of A Table . . . . . 8-22  
 Loading Tables . . . . . 8-25  
     Compile Time Tables . . . . . 8-25  
     Pre-execution Time Tables . . . . . 8-25  
     Loading Pre-execution Time Tables . . . . . 8-26  
 Output of an Entire Table . . . . . 8-28

**REVIEW 8 . . . . . 8-29**  
 Review Problem . . . . . 8-30

**CHAPTER 9. ARRAYS . . . . . 9-1**  
 Introduction . . . . . 9-2  
 When To Use an Array Instead of a Table . . . . . 9-2  
 Defining An Array . . . . . 9-2  
 Referencing All Elements In An Array . . . . . 9-4  
     Array to Array Calculations . . . . . 9-4  
     Calculations Using Arrays and Single Fields (Or Constants) . . . . . 9-7  
     Adding All Elements Within An Array . . . . . 9-8  
     Output of an Entire Array . . . . . 9-9  
     Accumulating Groups Of Totals . . . . . 9-14  
 Referencing Individual Elements of an Array . . . . . 9-19  
     Indexing An Array . . . . . 9-20  
     Output of Individual Elements of An Array . . . . . 9-22  
     Referencing Only Part of a Field . . . . . 9-23  
 LOKUP Of An Array . . . . . 9-27  
     Searching An Array For A Particular Element . . . . . 9-27  
     Searching An Array For More Than One Element . . . . . 9-32  
     Output During An Array Search . . . . . 9-34  
 Loading Arrays . . . . . 9-35  
     Compile Time Arrays . . . . . 9-35  
     Pre-execution Time Arrays . . . . . 9-36  
     Storing Input Data Into Execution Time Arrays . . . . . 9-38  
     Array Data Consecutive On More Than One Record (Model 6, Model 10 Disk System, and Model 15) . . . . . 9-44

**REVIEW 9 . . . . . 9-53**

**ANSWERS TO REVIEW 9 . . . . . 9-55**

**CHAPTER 10. WORKING WITH DATA STRUCTURE . . . . . 10-1**  
 Character Structure . . . . . 10-2  
     Representation Of Characters On 96-Column Cards . . . . . 10-2  
     Representation Of Negative Numbers . . . . . 10-3  
     Representation of Characters In Storage . . . . . 10-4  
     Difference Between Character Representation on Cards and In Storage . . . . . 10-4  
     Identifying Bit Combinations With Numerical Values . . . . . 10-13  
     Assigning Numerical Values to Zone and Digit Portions . . . . . 10-16  
     Saving Disk Storage Space . . . . . 10-19  
 Collating Sequence of Characters . . . . . 10-21  
     Collating By Zone or Digit . . . . . 10-25  
 Altering the Collating Sequence . . . . . 10-28  
     Specifying Changes In Collating Sequence . . . . . 10-28  
     Coding Characters To Be Equal . . . . . 10-33  
     Recording Specifications For The Altered Sequence . . . . . 10-38



Altering The Structure of Characters . . . . .	10-39
How Move Zone Operations Work . . . . .	10-39
Coding a Move Zone Operation . . . . .	10-39
Differences In The Move Zone Operations . . . . .	10-40
Field Format and Move Zone Operations . . . . .	10-41
Example of a Move Zone Operation . . . . .	10-41
Choosing the Model Character For Factor 2 . . . . .	10-42
Translating Characters . . . . .	10-44
Need For File Translation . . . . .	10-44
Specifying File Translation . . . . .	10-44
Recording Specifications For The Translation Table . . . . .	10-48
<b>REVIEW 10 . . . . .</b>	<b>10-49</b>
Character Structure . . . . .	10-49
Collating Sequence of Characters . . . . .	10-49
Altering The Collating Sequence . . . . .	10-50
Altering The Structure of Characters . . . . .	10-50
Translating Characters . . . . .	10-50
<b>ANSWERS TO REVIEW 10 . . . . .</b>	<b>10-51</b>

<b>CHAPTER 11. DEBUG . . . . .</b>	<b>11-1</b>
Introduction . . . . .	11-2
Using The DEBUG Function . . . . .	11-2
Specifications For DEBUG . . . . .	11-2
Format of Records Created By DEBUG . . . . .	11-4
Getting Results From DEBUG . . . . .	11-5
Placement of DEBUG . . . . .	11-5
Making Your Program Work For All Cases . . . . .	11-5
<b>REVIEW 11 . . . . .</b>	<b>11-7</b>
<b>ANSWERS TO REVIEW 11 . . . . .</b>	<b>11-8</b>
<b>INDEX . . . . .</b>	<b>X-1</b>

**CHAPTER 1 DESCRIBES:**

Basic RPG II logic.

RPG II logic related to indicators.

**AFTER READING THIS CHAPTER YOU SHOULD BE ABLE TO DESCRIBE:**

Basic three-step logic of a data processing job.

Detail time and total time.

Specific steps in a basic RPG II job that includes detail and total operations.

RPG II logic related to the following indicators: 1P, LR, record identifying indicators, field indicators, resulting indicators, halt indicators (H1-H9), overflow indicators (OA-OG, OV), matching records indicator (MR).

*Note:* You can use the review questions contained in *Review 1* at the end of this chapter to test your comprehension of the chapter. Answers follow the review questions.

## INTRODUCTION

What procedures do you follow if you are preparing bills to send to customers? Before you can do anything you need some information. You have to know three things: (1) the customer's balance at the beginning of the month; (2) his purchases; and (3) his payments. Once you have gathered this information, you can perform the necessary calculations to find the amount due. Finally you record this amount on the bill. You go through these same procedures for each customer.

This is a type of job you can easily have your computer do for you. To do the job, however, the computer must know the same things you know. You must, therefore, tell it exactly what information to expect, what to do with the information, and what to give you as a result. This you do through specifications you write: File Description; Extension; Line Counter; Input; Calculation; and Output-Format.

To do this billing job, you do things in a logical order. You read information first. You do calculations second. Finally, as a result of the calculations, you record the amount owed. Then you begin to do the same things in the same order for the next customer.

The computer must also do things in a logical order. The information you supply through specifications doesn't give the computer the logic it needs to do your job; the RPG II Compiler supplies this. RPG II logic supplied by the compiler is the framework for your job. When your source program is compiled, your source statements are fitted into the framework of RPG II program logic to make a complete program. The generated program then has all the information it needs to do your job in a logical manner.

What happens if, in doing your billing job, you find that a customer paid more than he owed? You know immediately that he has a credit balance and indicate so on the invoice. How does the RPG II program recognize this situation? And how does it know what to do when such a situation occurs?

The RPG II program uses signals which tell it when a particular situation occurs and what to do when that situation does occur. These signals are known as indicators. There are many different kinds of indicators which signal many different situations. You, as a programmer, must know how to specify the indicators so that they signal to the computer what you want them to.

RPG II logic is built around these indicators. Their status (on or off) affects the sequence of the program's operations. The logic is set up to test the status of various indicators at specific times. By testing indicators, the program knows what to do next.

RPG II program logic is designed to take care of all types of jobs. You must understand this logic to write specifications which make correct use of it.

Because the logic is a rather complex topic, it is described segment by segment. However, when you have finished reading this section, you will have a picture of how the complete RPG II program logic works.

## BASIC DATA PROCESSING LOGIC

Usually, all records in a file of input records are not read at once. Your computer probably is not large enough to store and work with information from all records at the same time. Therefore, records are read one at a time. Three steps, as shown in Figure 1-1, are done for each record read.

The phrase *program cycle* refers to all the operations performed from the time one record is read until the next record is read. One program cycle is therefore one revolution around the circle used to illustrate the program logic. Since one program cycle (one revolution) is needed for each record read, many program cycles are required for every job.

Consider how the three step logic shown in Figure 1-1 works for a job which requires a detailed listing of purchases made by each customer. The input file is in ascending order by customer number. Each record contains customer name (NAME), number (NUM), and charge (CHRG). Information from the record is merely transferred to the printed page. One line is printed for each record read. Each record read is known as a detail record and each line printed is a detail line.

The job begins: the first record is read. No calculations are performed. A record is then printed. This ends the first program cycle. The second begins with the reading of another record. Figure 1-2 shows the input and output of the detail printing job.

Suppose, however, instead of merely listing the charges made by each customer you also wish to find the total charges for each customer, as shown in Figure 1-3.



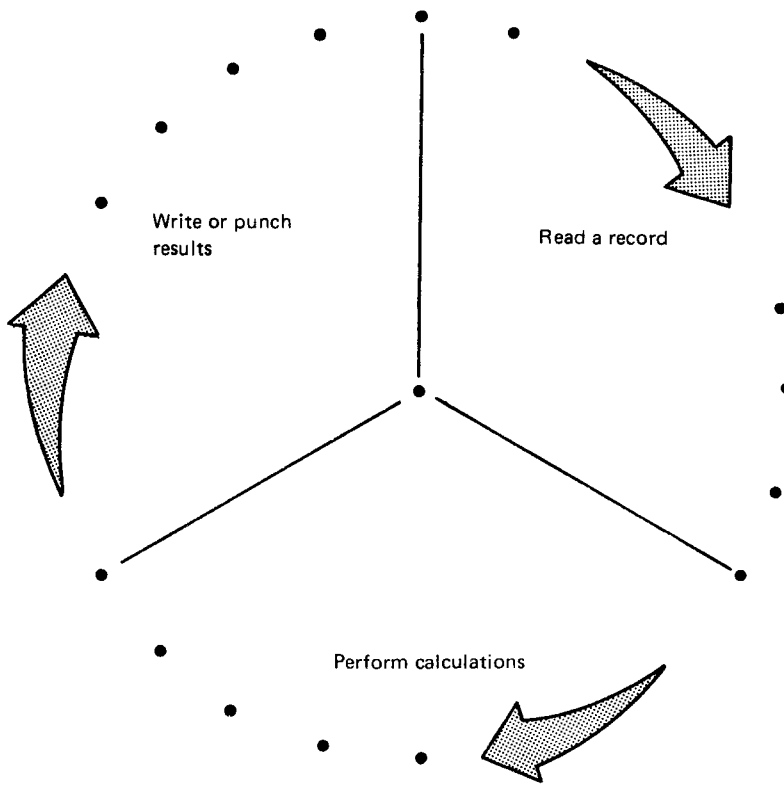

Figure 1-1. Basic Logic of a Data Processing Job

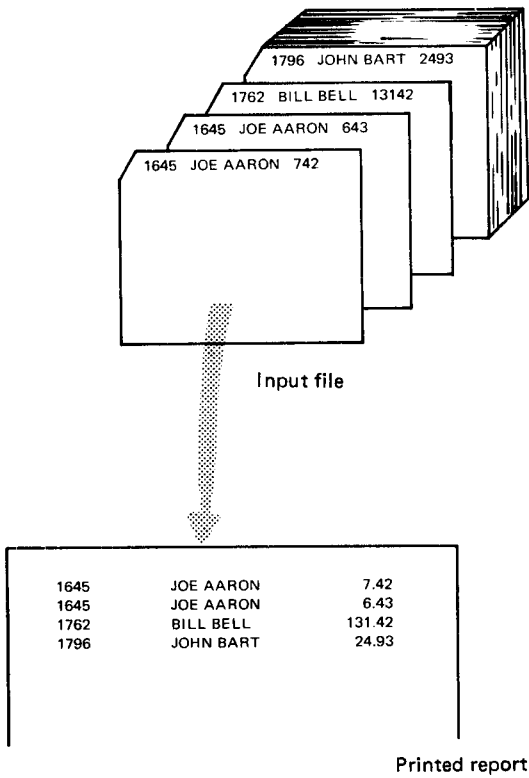

Figure 1-2. Detail Printing Job

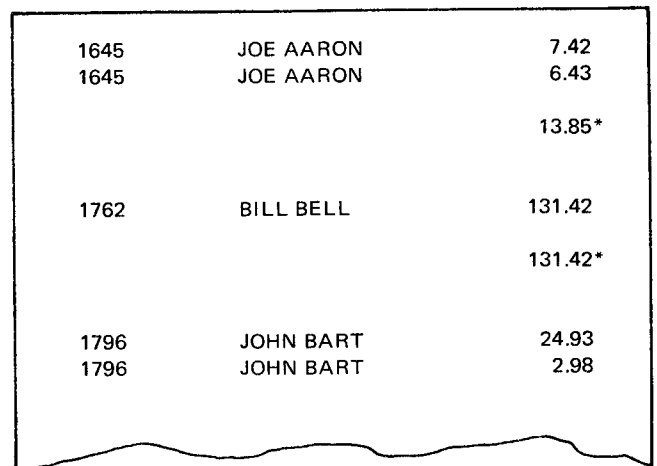

Figure 1-3. Calculating and Printing Totals

To do this, you must do calculations to accumulate a total in addition to printing out individual (detail) records. But when do you print out the total you have calculated? The total for a customer, of course, should be printed after all detail records for that customer have been printed (Figure 1-3). However, in the three-step logic discussed so far, there is no provision for printing a total record. Neither is there a way to distinguish between individual input records in order to determine when all records for a customer have been read.

If the RPG II program used only the three-step logic, it would not be able to do this job and many others like it. It could adequately work with information from only one record at a time, as in the detail printing job. It could not correctly do operations to accumulate data from several records.

## BASIC RPG II LOGIC

RPG II logic, therefore, is an extended version of this 3-step logic. It calls for calculations and output operations to be done at two different times in one program cycle (see Figure 1-4). The names *detail* and *total* have been given to the times at which calculation and output operations are performed. Total time, as the name suggests, is the time in which total operations are done on data accumulated from a group of related records. The printing of total charges for Joe Aaron (Figure 1-3) is an example of a total time operation. Detail time is the time in which operations are performed for individual records. An example of a detail time operation is the printing of an individual charge for Joe Aaron. Remember, detail operations are done for every record read, but total operations are done only after a certain group of records are read (see Figure 1-5).

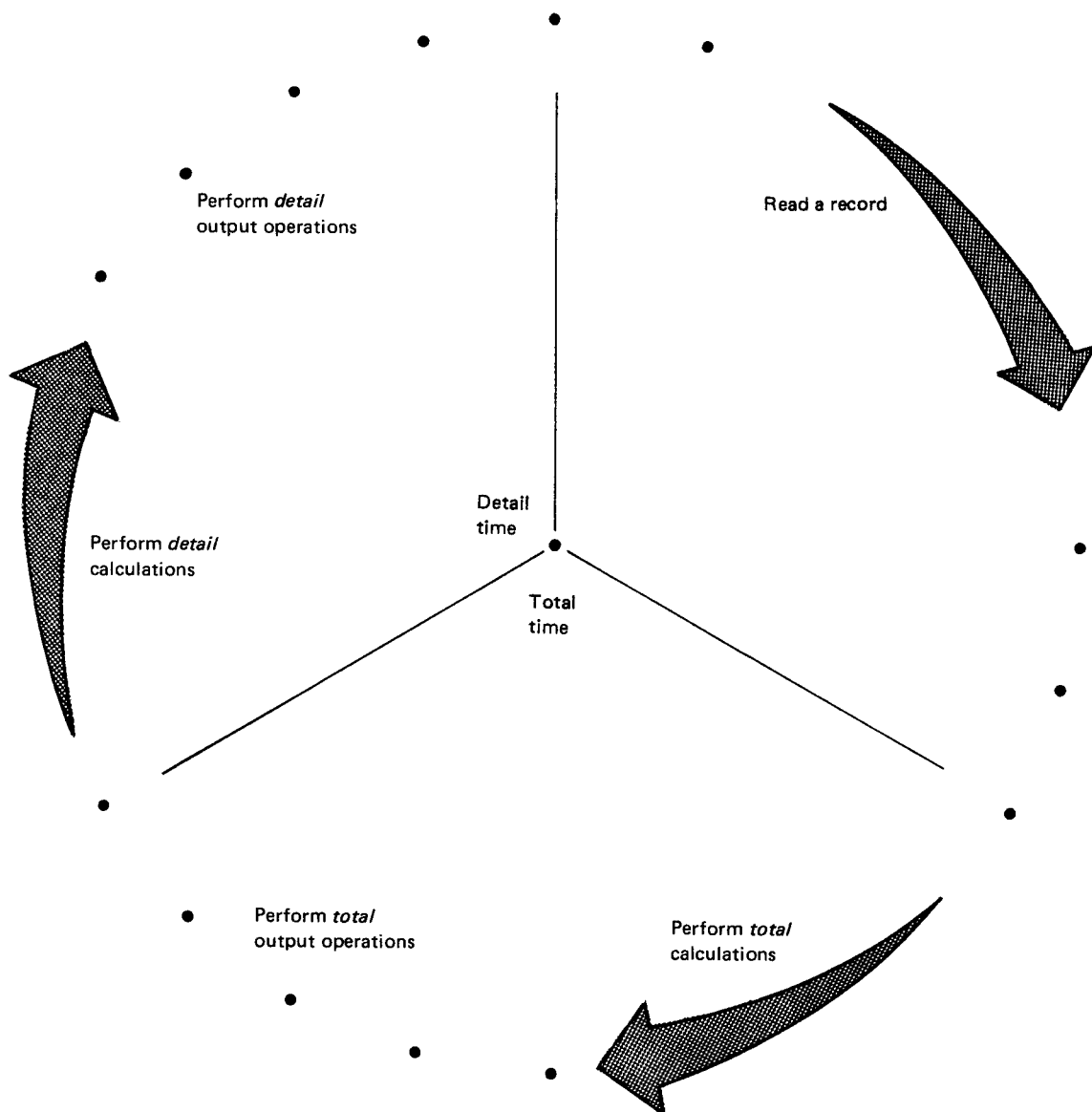

Figure 1-4. Basic RPG II Logic

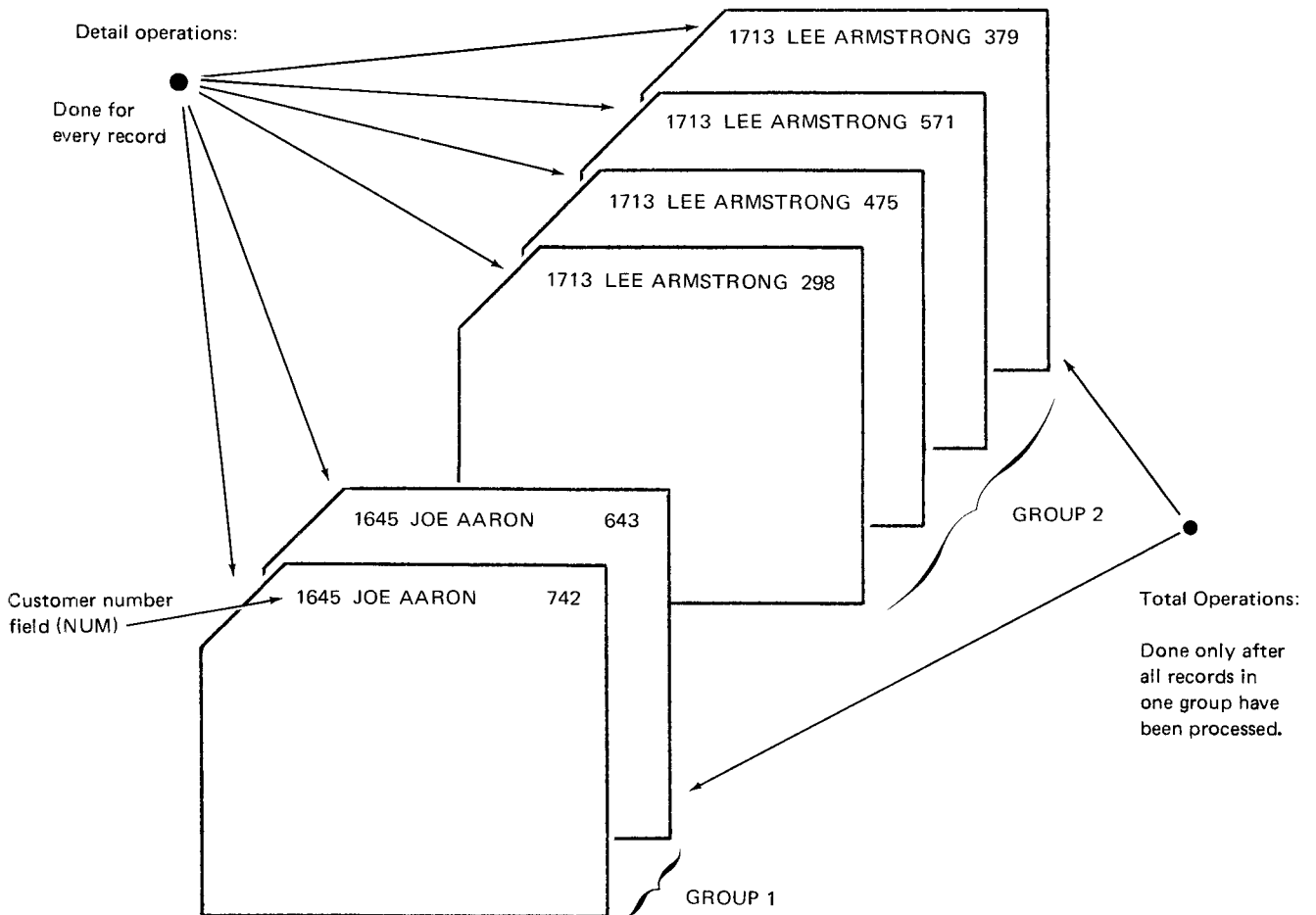

Figure 1-5. Detail Versus Total Operations

Because this basic RPG II logic is only a framework for your job, you have to supply additional information so that your job will be complete. Only then will your program work correctly. For example, the RPG II compiler supplies your program with the logic framework which enables it to do detail and total operations. But you must tell it *when* total operations should be done and which calculation and output operations are to be done at detail time and which are to be done at total time.

Remember that the only way you can tell the program what to do in certain situations is to use indicators. Control level indicators are used to tell the program:

1. When to do total operations.
2. What operations are total operations.

If you were finding total monthly charges for each customer, how would you know when to record totals for each customer? When you encounter a record with a dif-

ferent customer number in the NUM field, you know that you have gathered all the information for one customer. (You could use the NAME field to tell you this, but there is a chance that two customers may have the same name.) You would then record that total before gathering information for the next customer.

Any field used to control and direct processing is known as a *control field*. You indicate to the compiler program which field is a control field by assigning one of the control level indicators (L1-L9) to the field in columns 59-60 of the Input sheet. You also use this same control level indicator to tell the program which calculations are total calculations by entering the indicator in columns 7-8 of the Calculation sheet. Those calculations that are not conditioned by a control level indicator (in columns 7-8) are detail calculations. Control level indicators are not used in the Output-Format sheet to indicate detail and total records. Rather a T is used in column 15 to indicate a total output operation; and H or D is used to indicate an operation done at detail time.

### Specific Steps in Basic RPG II Logic

Figure 1-4 shows very generally the sequence of events in an RPG II program cycle. The RPG II logic actually consists of definite steps taken during the cycle. When you do a job you mentally ask yourself questions such as, "Do I do this now? Do I have all my information? What should I do next?" RPG II logic also asks questions. It uses your program to find the answer and thus determines what to do next. The questions, and specific steps taken based on the answers to the questions, are shown in Figure 1-6.

According to RPG II logic, after a record is read the program checks to see if information in the control field of the record just selected is different from the control field information in the previous record. (The program always saves the control field information so that it can make a comparison.) If there is a change, the proper control level indicator (the one you assigned) is turned on. This means that all records from one group have been read. All total operations can then be performed. Control level indicators are always turned off before the next record is read.

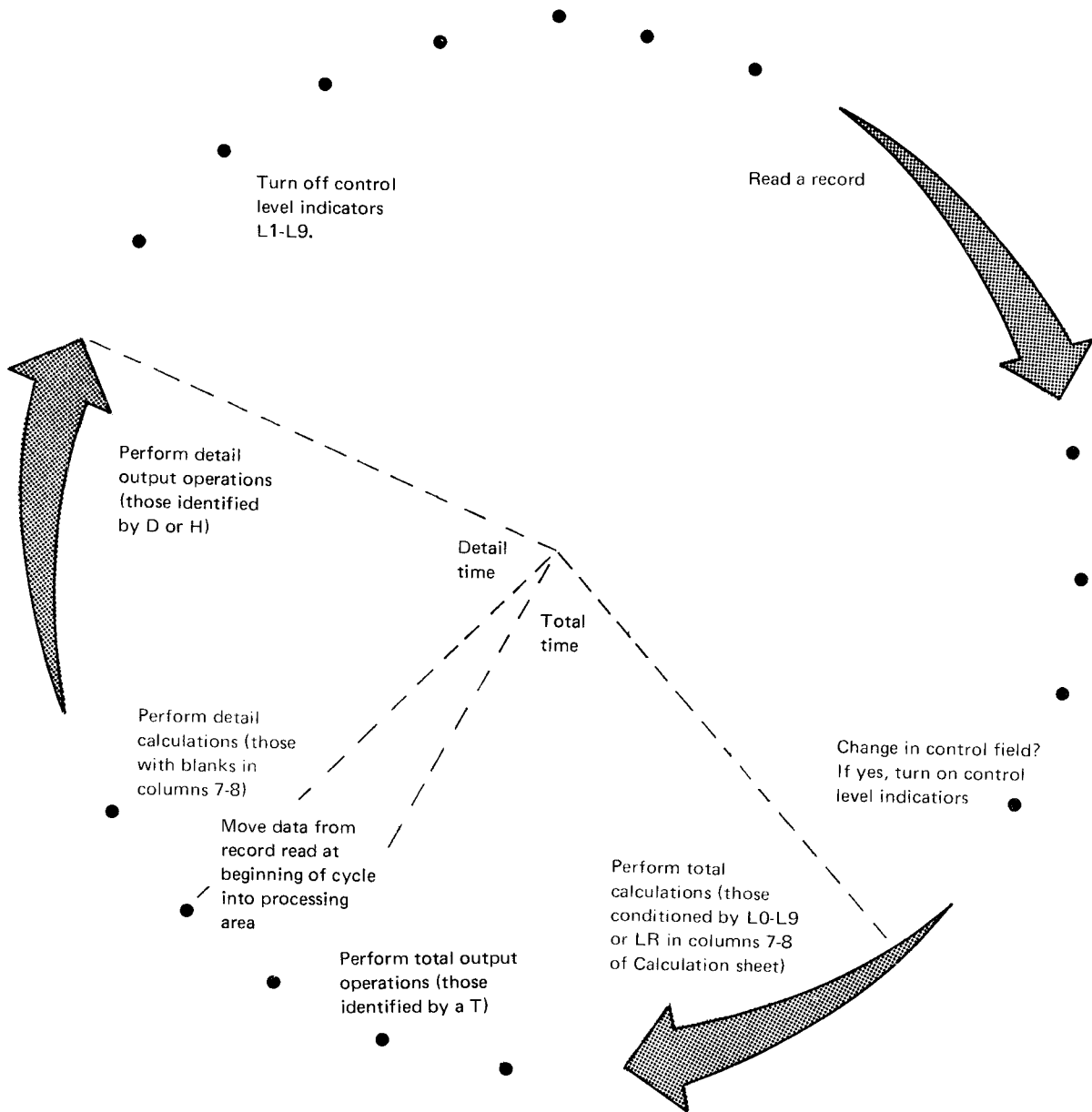

Figure 1-6. Steps in RPG II Total and Detail-Time Logic



Notice the step between total and detail time. Here data from the record read at the beginning of the cycle is moved into a processing area and becomes available to use in calculations and output. Data from this record is not available at total time. Total operations are performed only on data accumulated from previous records. Detail operations on the record which caused the control level indicator to be turned on are done only after total operations for previous records.

Why are total operations done before detail operations? Think of what would happen if the record which caused the control level indicators to be turned on were processed. Information on this record would be added to information from records in the previous group. As a result, the totals printed would be in error since they contained information from one record in the next group (the record just read). To prevent data from the first record in a new control group from being accumulated in the totals for the previous group, total operations are done before detail operations.

### First Program Cycle

When control fields are specified for a record, the first program cycle may be slightly different from the others.

Control level indicators are turned on by the first record containing control fields. This happens because contents of the control fields on this record are different from the blank control field areas that were in main storage before the record was read. To prevent printing of blank totals on the first cycle, RPG II logic causes total operations to be bypassed on the first cycle.

*Note:* If the initial input records do not contain a control field, total calculations and total output operations are bypassed on each program cycle through and including the first cycle in which a record with control fields is read.

## Summary of Basic RPG II Logic

Figure 1-7 shows specifications for the group printing job previously discussed and the logic for the first four program cycles. Follow the logic involved in each program cycle step by step. Remember, the cycle repeats itself from the time the program is started until the last record is processed.

Be sure you understand this basic logic before proceeding further.

## RPG II LOGIC RELATED TO INDICATORS

It was previously stated that RPG II logic is built around indicators. This section discusses how logic related to indicators fits into the basic RPG II detail and total time logic shown in Figure 1-4.

In your specifications, you use indicators to tell the program what to do and when to do it. Although you use indicators, you do not set them. Naturally the indicators don't turn on and off by themselves. The compiler supplies logic which is needed to control the setting of indicators.

Indicators are set to signal various conditions that occur during the execution of a program. In addition to setting indicators, RPG II logic also causes tests to be made for various indicators at certain times in the program cycle. Specific operations are performed as a result of these tests.

It is very easy to think that an indicator is on when it really is off or vice versa. It is extremely important that you know when indicators are on and when they are off in the program cycle. Many programs fail just because the programmer did not understand RPG II logic concerning indicators. The following paragraphs will discuss the time in the program cycle at which indicators are set and the time at which they are tested.

**IBM** International Business Machine Corporation  **RPG INPUT SPECIFICATIONS**  GX21-9094 U/M 050\*  
Printed in U.S.A.

Program					Punching Instruction					Graphic					Card Electro Number				
Programmer					Date					Punch									

Page 1 of 2 Program Identification 75 76 77 78 79 80

Line	Form Type	Filename	Sequence Number (L-N)	OR AND	Record Identifying Indicator or Division (OI)	Record Identification Codes									Field Location		Field Name	Decimal Positions	Field Control Level (L1-L9)	Matching Fields or Chaining Fields	Field Record Relation	Field Indicators		
						1	2	3	4	5	6	7	8	9	10	11						12	13	14
0 1	I	CHARGES	AA														2	5	NUM		LI			
0 2	I																6	25	NAME					
0 3	I																26	322	CHG					
0 4	I																							
0 5	I																							

**IBM** International Business Machine Corporation  **RPG CALCULATION SPECIFICATIONS**  Form GX21-9093  
Printed in U.S.A.

Program					Punching Instruction					Graphic					Card Electro Number				
Programmer					Date					Punch									

Page 1 of 2 Program Identification 75 76 77 78 79 80

Line	Form Type	Control Level (L0-L9)	L1	S1	P1	AND	AND	Indicator	Factor 1	Operation	Factor 2	Result Field Name	Length	Decimal Positions	Half Adjust (H)	Resulting Indicators		Comments
																Plus	Minus	
0 1	C								CHG	ADD	TOTAL	TOTAL	82					
0 2	C																	

**IBM** International Business Machine Corporation  **RPG OUTPUT SPECIFICATIONS**  GX21-9090 U/M 050\*  
Printed in U.S.A.

Program					Punching Instruction					Graphic					Card Electro Number				
Programmer					Date					Punch									

Page 1 of 2 Program Identification 75 76 77 78 79 80

Line	Form Type	Filename	OR AND	Type (H/D/T/E)	Space	Skip	Output Indicators									Field Name	Edit Codes B/A/C/I/S/R	End Position in Output Record	P/B/L/R	Constant or Edit Word	
							And	And	Not	Not	Not	Not	Not	Not	Not						Not
0 1	O	PRINT																			
0 2	O																				
0 3	O													NUM		10					
0 4	O													NAME		40					
0 5	O													CHG	1	60					
0 6	O	T 23																			
0 7	O													TOTAL	18	60					
0 8	O															61					
0 9	O																				
1 0	O																				

Figure 1-7 (Part 1 of 5). Illustration of Detail and Total Time

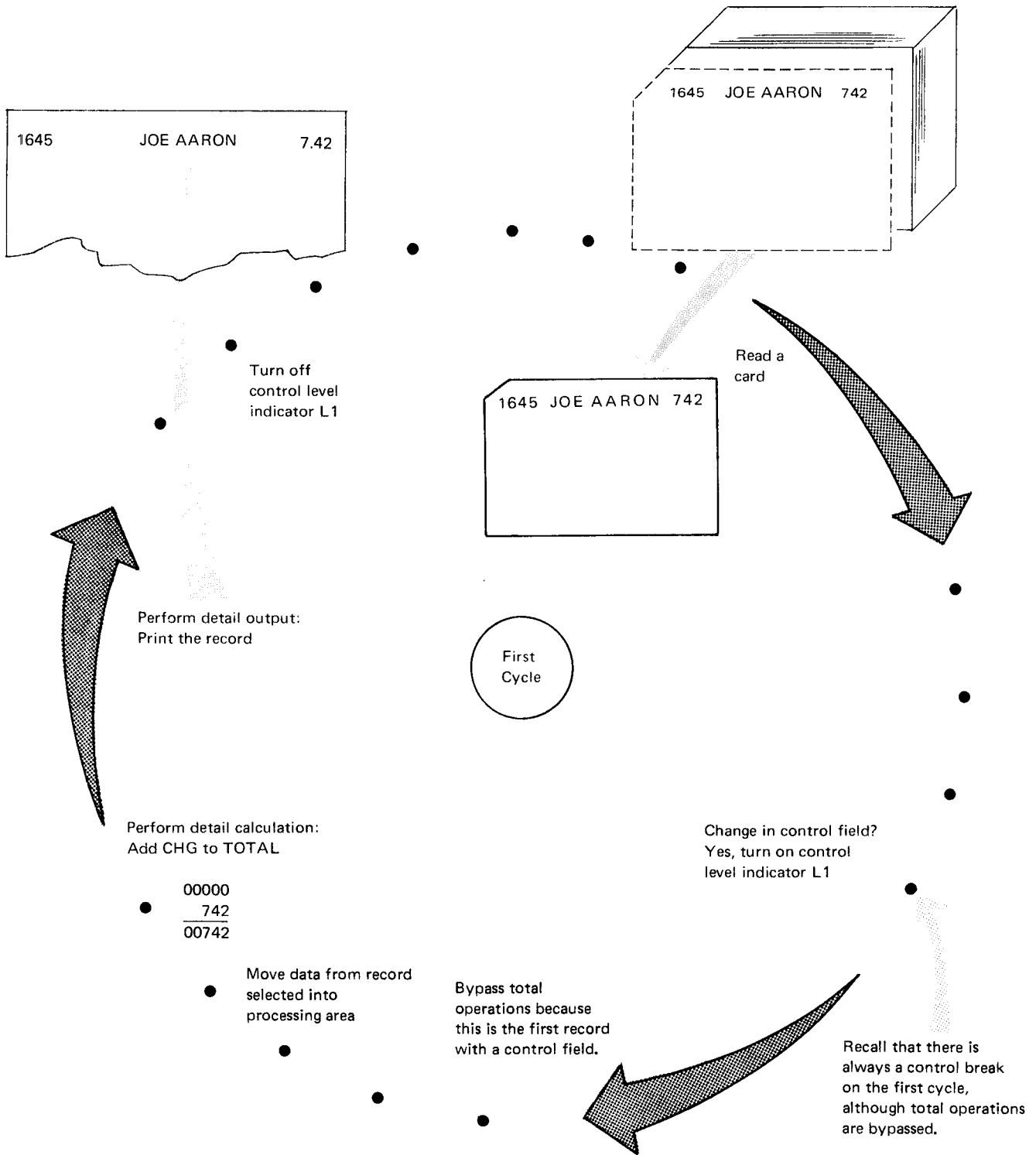

Figure 1-7 (Part 2 of 5). Illustration of Detail and Total Time

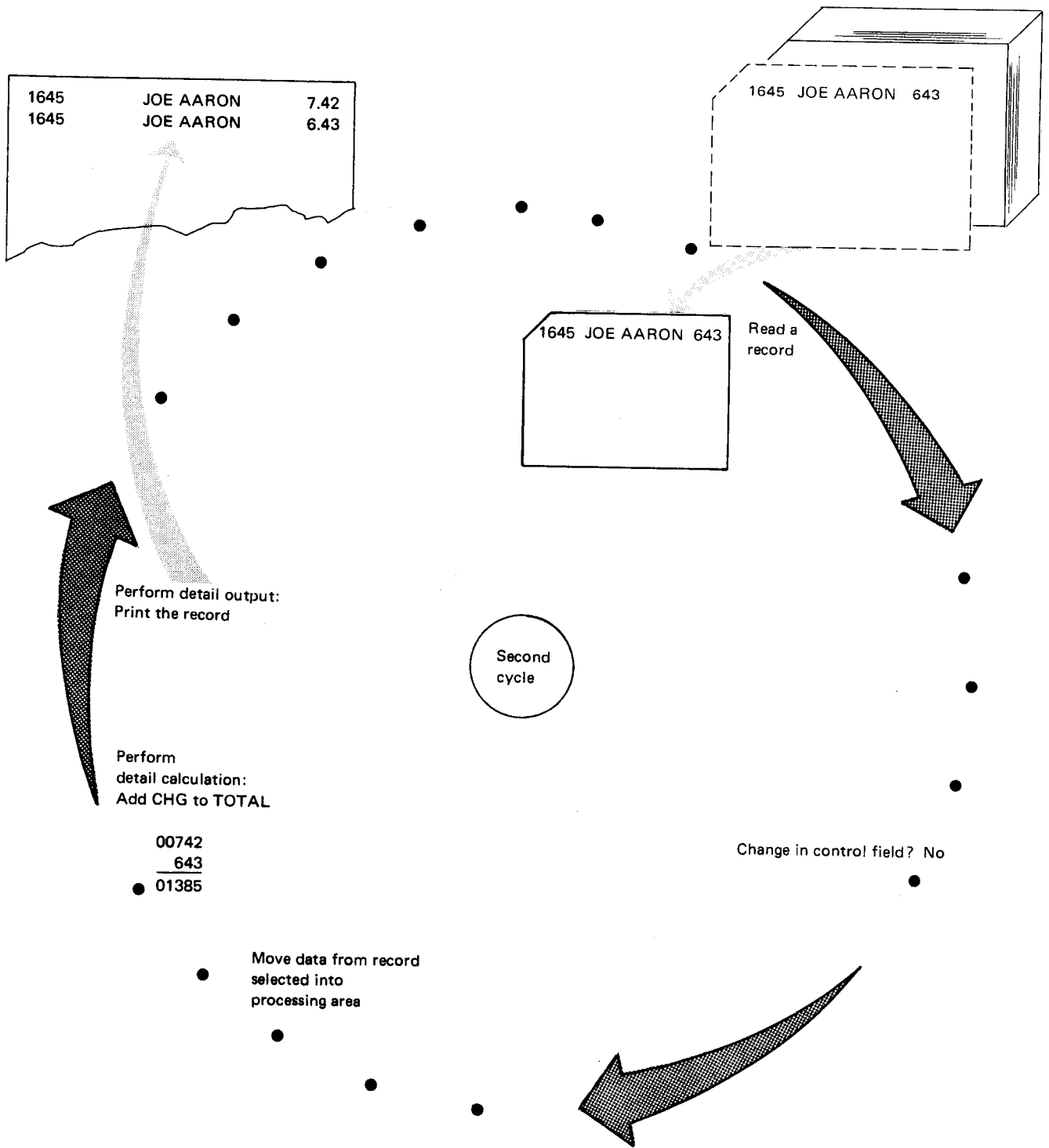

Figure 1-7 (Part 3 of 5). Illustration of Detail and Total Time

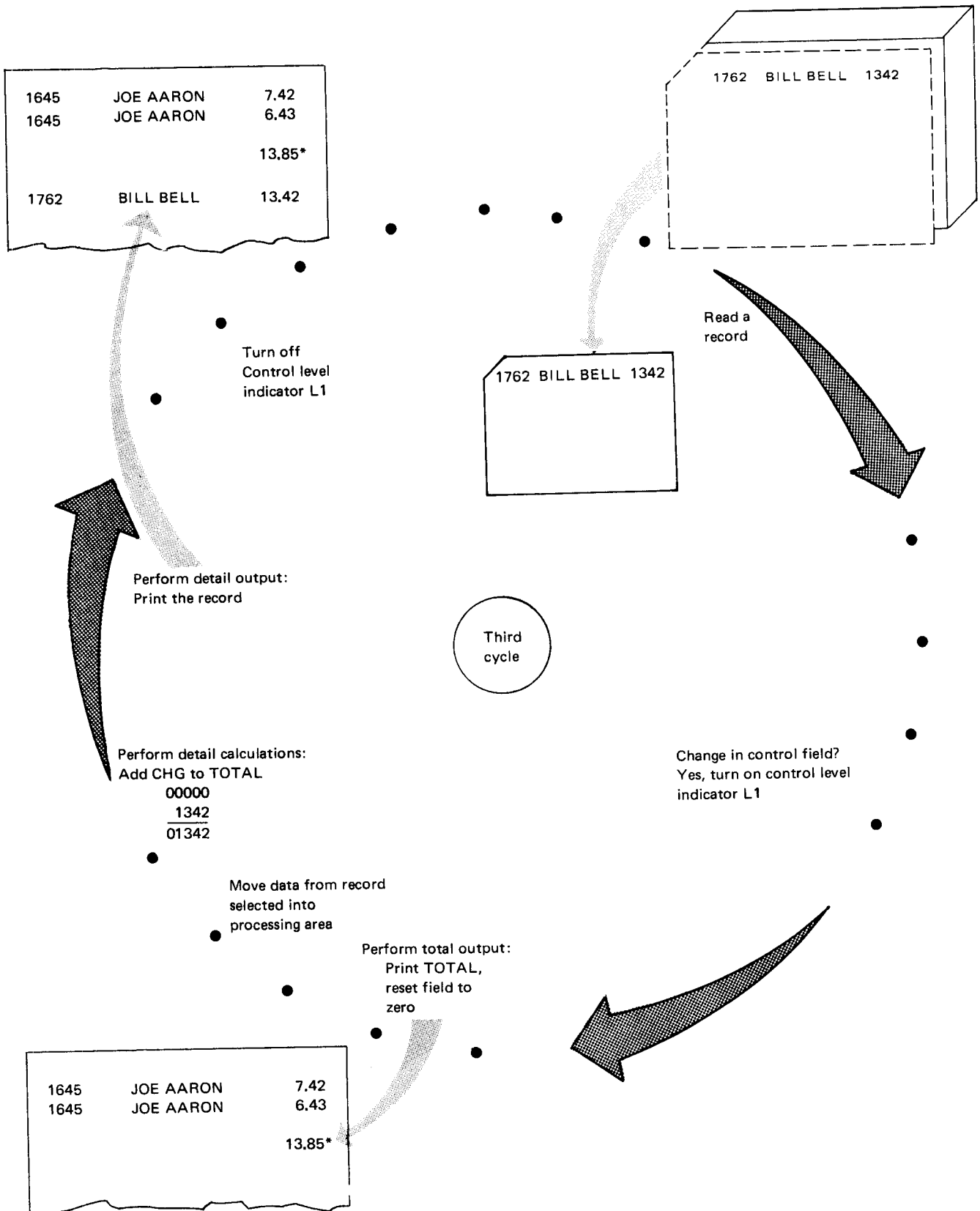

Figure 1-7 (Part 4 of 5). Illustration of Detail and Total Time



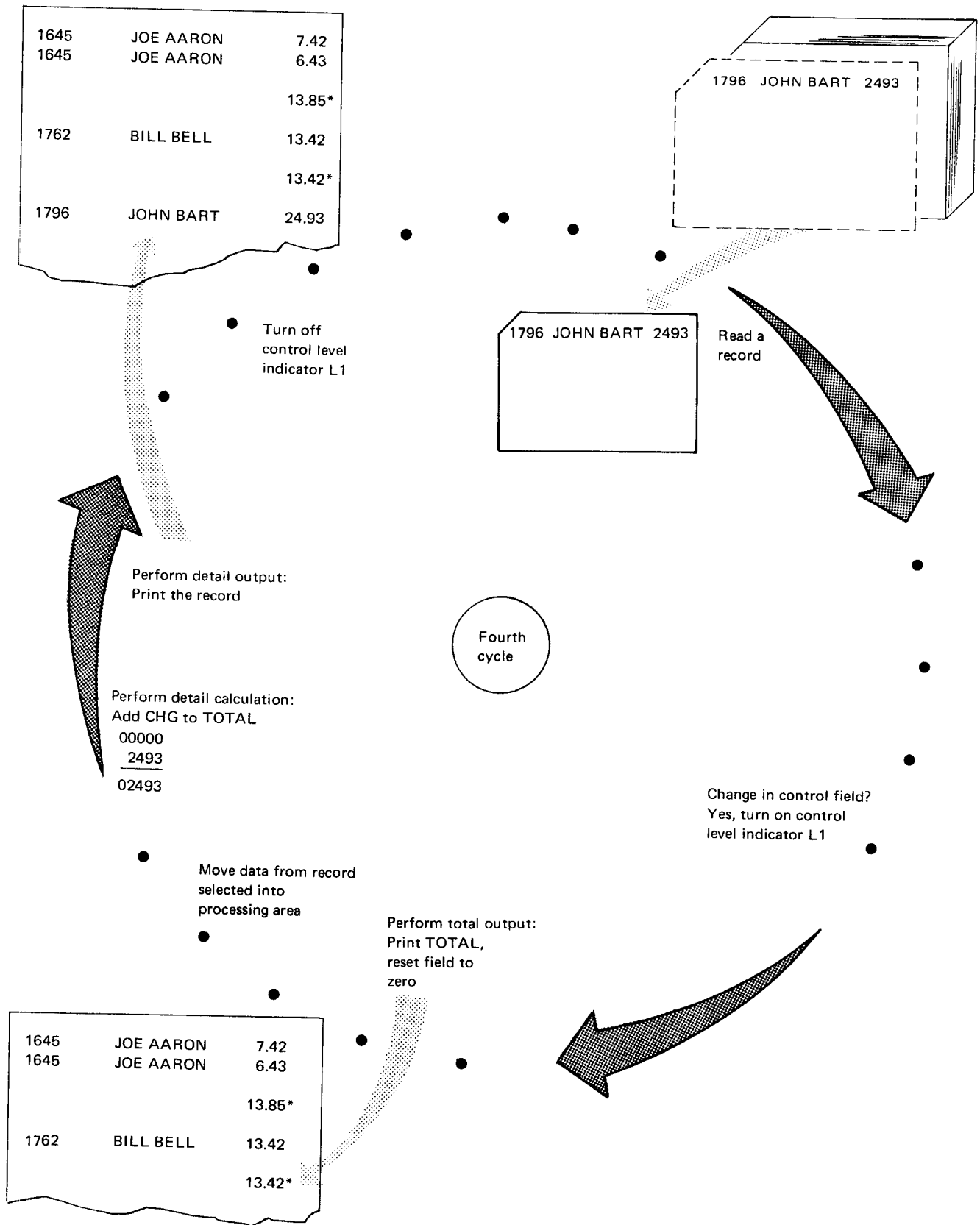

Figure 1-7 (Part 5 of 5). Illustration of Detail and Total Time

## 1P (First Page) Indicators

It was stated before that the first program cycle is slightly different from the others because total operations are bypassed on the first cycle. Another difference in the first cycle is that the first page indicator (1P) is on during the beginning of the cycle. Any records conditioned by the 1P indicator are printed *before* the first record is read.

This indicator is used to condition records which are to be printed on the first page of a report. These records are usually headings used to identify information found on the page, but may also be detail lines.

The 1P indicator is turned on only for the beginning of the first cycle. It is turned off before a record is read and is never used again during the program (see Figure 1-8).

Notice in Figure 1-8 that the program performs 1P output and other heading and detail output *first* when it is started. *This is always true.* In any program, 1P output and any other heading or detail output for which specified conditions have been met is performed before the first record is read. On succeeding cycles, however, it is usually easier to think of reading a record as the first step in the cycle.

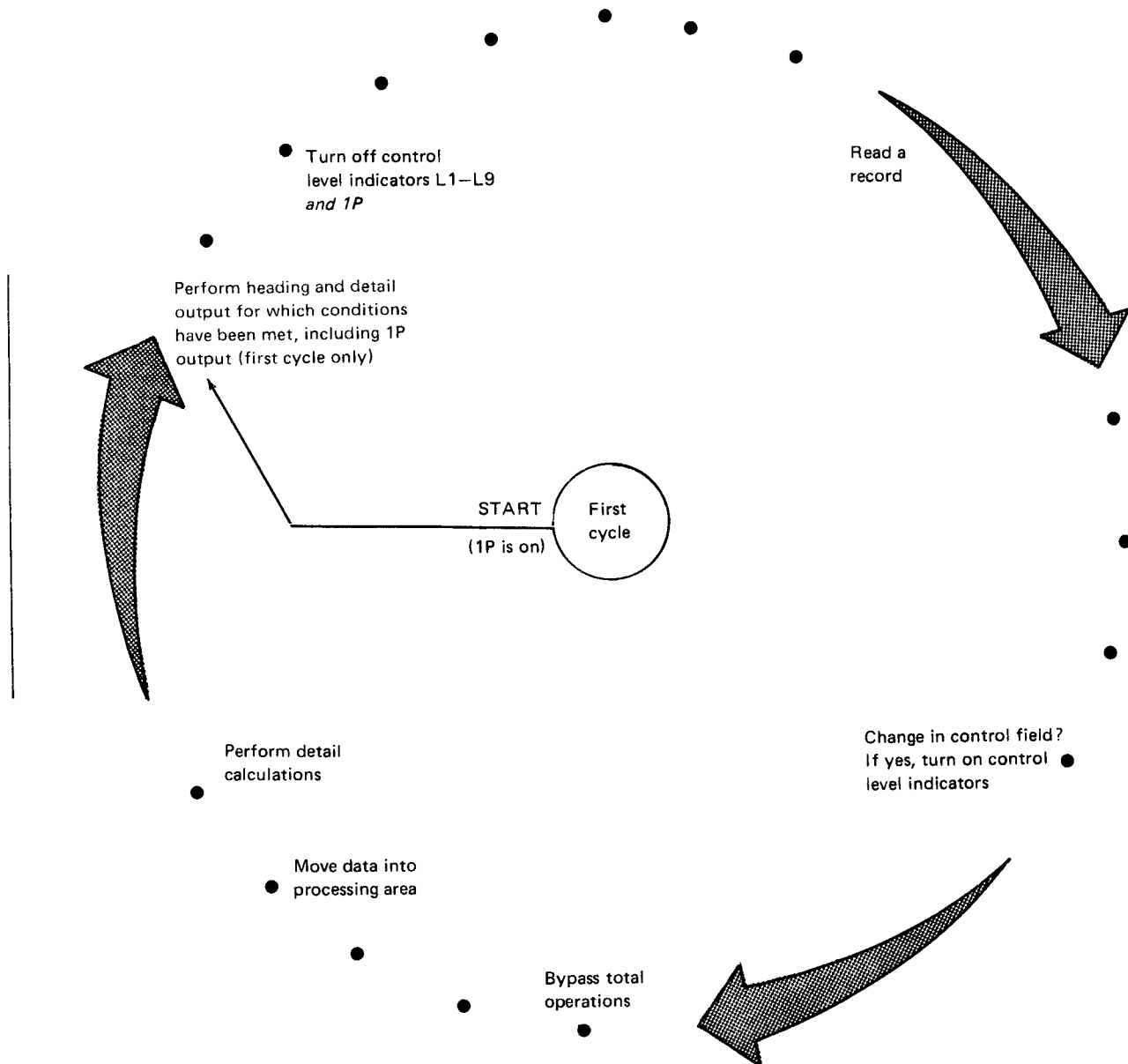

Figure 1-8. Logic for the First Page (1P) Indicator

Assume that a heading is desired on the report created by the previous example (Figure 1-7). The heading should be printed on the first page before any records are printed. Thus the heading line is conditioned by 1P (see Figure 1-9). Figure 1-10 shows what happens in the first cycle according to RPG II logic.

**RPG OUTPUT SPECIFICATIONS**

IBM International Business Machine Corporation GX21-9090 U/M 050\*  
Printed in U.S.A.

Program		Punching Instruction		Graphic		Card Electro Number	
Programmer	Date						

Page 1 of 2 Program Identification 75 76 77 78 79 80

Line	Form Type	Filename	Type (H/D/T/E)		Space	Skip		Output Indicators			Field Name	Edit Codes B/A/C/I S/R	End Position in Output Record	P/B/L/R	Constant or Edit Word	
			Shifter # (Frac/E)	Before		After	Not	And	And	Not						Commas
01	O	PRINT	H	32				1P								
02	O												10		'NUMBER'	
03	O												30		'NAME'	
04	O												60		'CHARGES'	
05	O		D	L				01					10		NUM	
06	O												40		NAME	
07	O												60		CHG	

Yes	Yes	1	A	J	X
Yes	No	2	B	K	Y
No	Yes	3	C	L	Z
No	No	4	D	M	

X - Remove Plus Sign  
Y = Date Field Edit  
Z = Zero Suppress

Figure 1-9. Heading Line Conditioned by the First Page Indicator

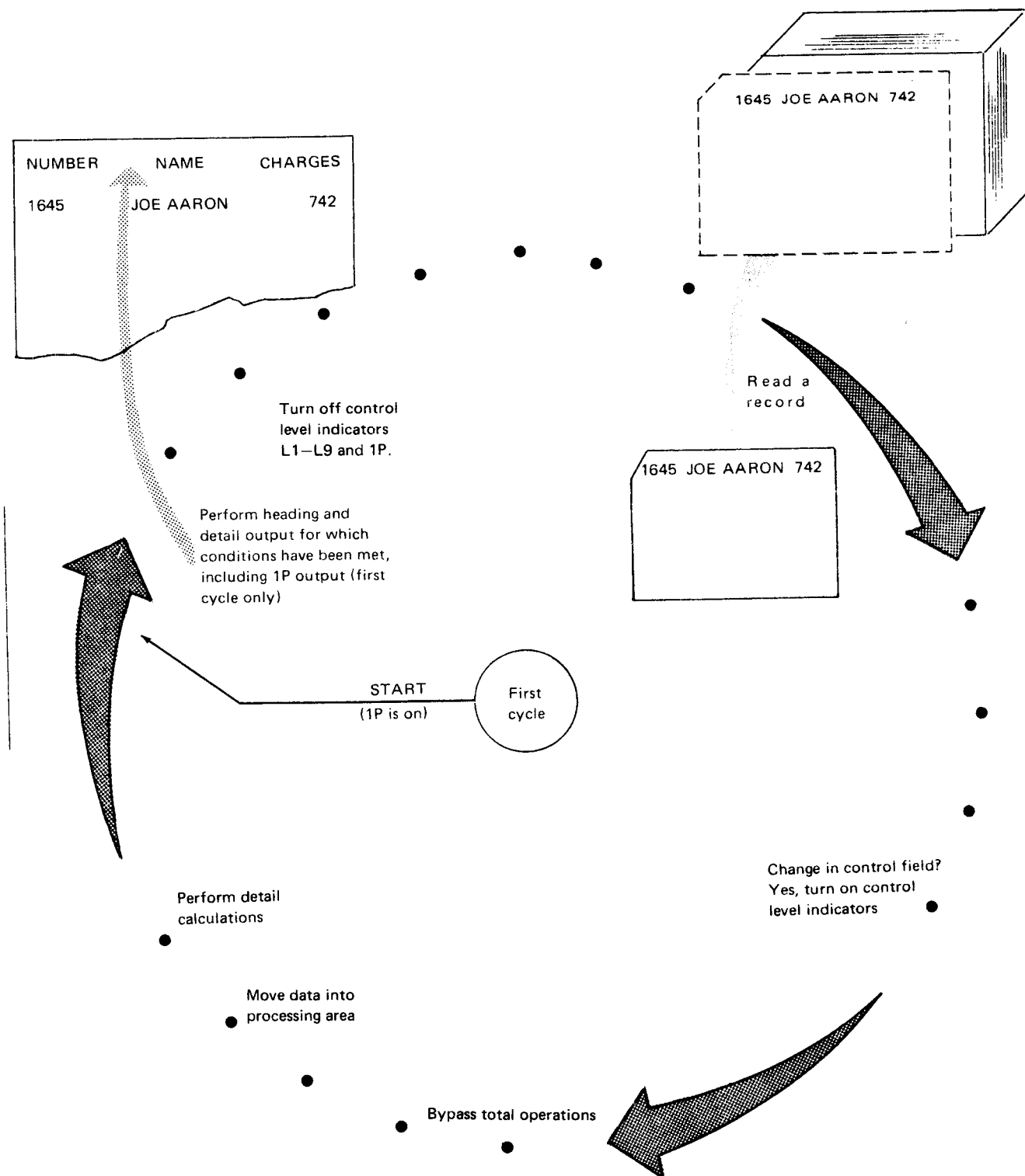

Figure 1-10. Program Cycle Illustrating the 1P Indicator

## Last Record Indicator (LR)

The last program cycle is also a little different from the others. When the record with a /\* in positions 1 and 2 is read, the LR (last record) indicator is turned on. Since the /\* record has no data on it, detail operations need not be performed. Thus RPG II logic is set up so that detail operations are not done when LR is on (see *Note*). Total operations are done. The program then ends.

When the last record indicator is turned on, all control level indicators are also turned on. Thus all total operations conditioned by L1-L9 and LR are performed. See Figure 1-11 for specific steps in the end of job logic.

You use LR to condition all operations done at the end of the job. These usually include the calculating of totals for all records and/or writing or punching summary information. Suppose the previous example (Figure 1-7), which found total charges for each customer, required the statement *List Complete as of \_\_\_\_\_* (date job was run). Since this is to print out after all records have been processed, it is conditioned by LR (see Figure 1-12). Figure 1-13 shows what happens during the last program cycle according to RPG II logic.

*Note:* Detail operations are done if LR has been turned on during calculations, rather than by reading a /\* record. However, when LR is turned on in calculations, the other control level indicators are not turned on.

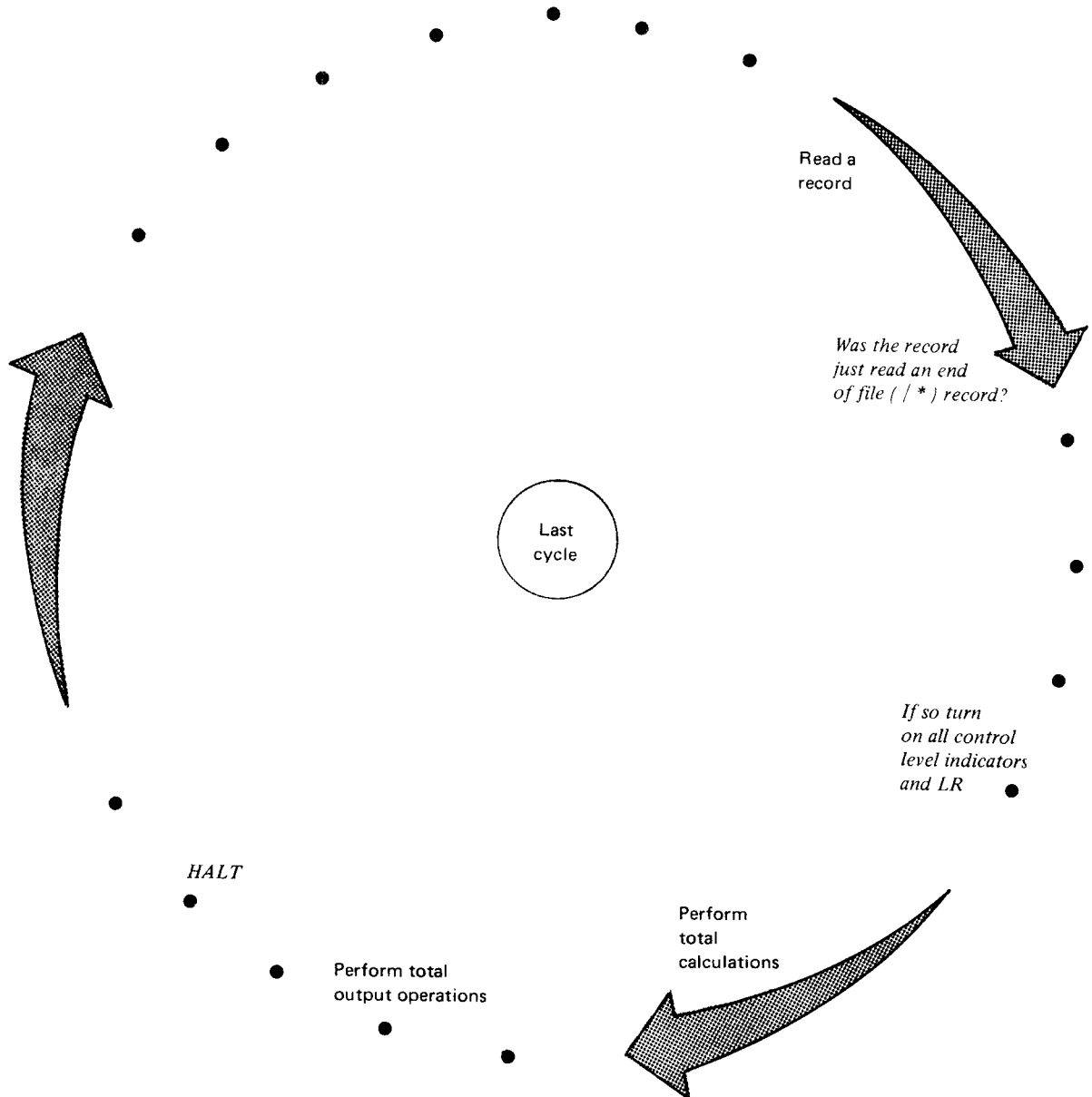

Figure 1-11. Logic for the Last Record (LR) Indicator

RPG OUTPUT SPECIFICATIONS

GX21 9090 LHM 0507  
 Printed in U.S.A.



Program	Date	Punching Instruction	Graphic	Card Electro Number
Programmer			Punch	

Page 1 of 2      Program Identification 75 76 77 78 79 80

Line	Form Type	Filename	Type (H/D/T/E)			Space		Skip			Output Indicators			Field Name	Edit Codes B/A/C/T/S/R	End Position in Output Record	P/B/L/R	Commas	Zero Balances to Print	No Sign	CR	-	X	Remove Plus Sign				
			A	D	E	Before	After	Before	After	Not	And	And	Y												Date	Field Edt	Zero	Suppress
			O	R					Not	And	And		Z															
01	O																											
07	O																											
08	O																											
09	O																											
10	O																											
11	O																											
12	O																											

Commas	Zero Balances to Print	No Sign	CR	-	X	Remove Plus Sign
Yes	Yes	1	A	J	Y	Date
Yes	No	2	B	K		Field Edt
No	Yes	3	C	L		Zero
No	No	4	D	M		Suppress

Constant or Edit Word

\*AUTO

UPDATE Y

51 '\*'

53 'LIST COMPLETE AS OF'

62

Figure 1-12. Total Lines Conditioned by LR

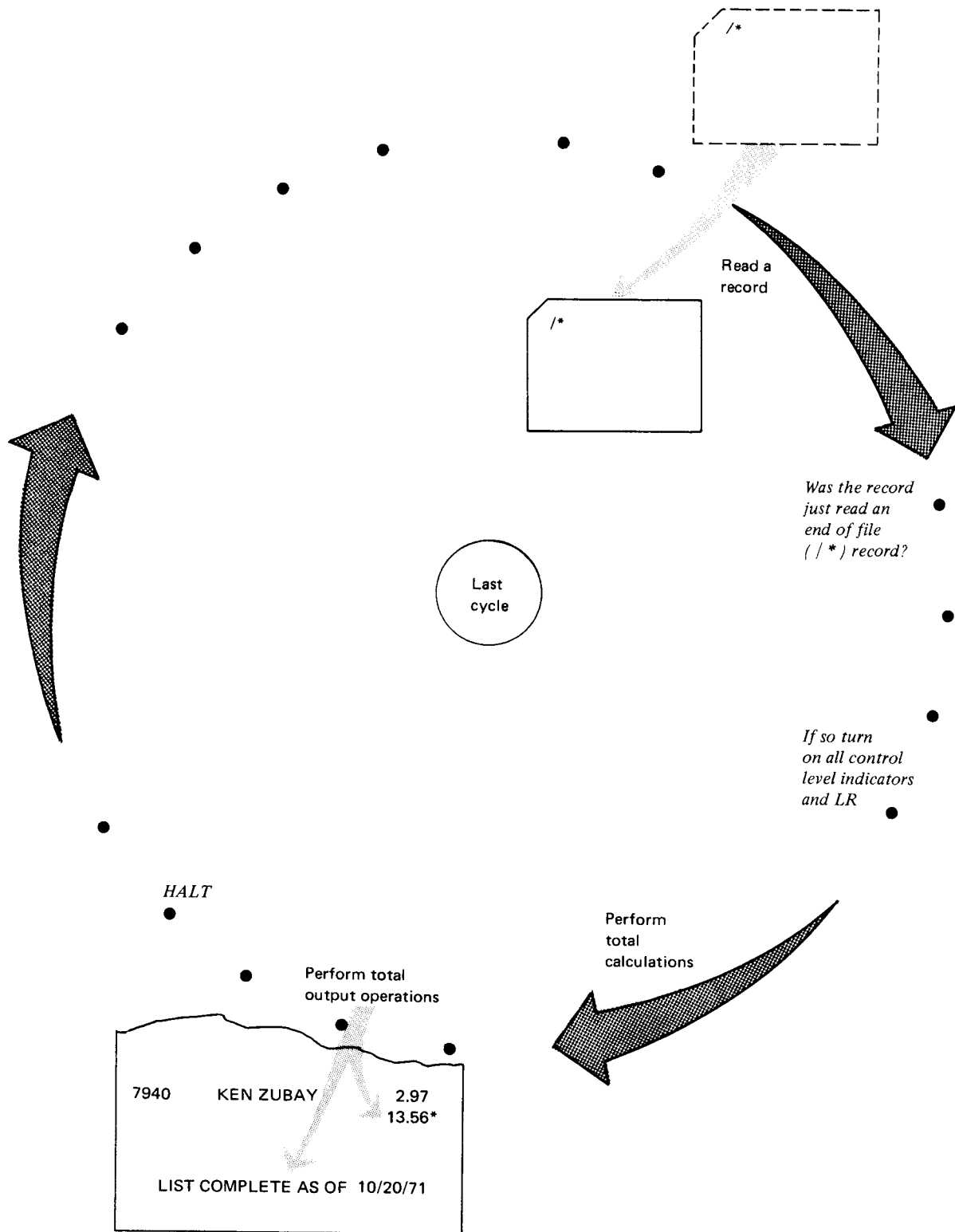

Figure 1-13. Program Cycle Illustrating the LR Indicator

### Record Identifying Indicators (01-99)

You assign a record identifying indicator to each type of record in the input file. If certain operations are to be performed for one record type only, you may condition those operations by the appropriate record identifying indicator. By this method you can tell the RPG II program what operations to perform when it processes a specific record type.

After the program has selected the next record to process, it turns on the record identifying indicator which you assigned to that record type. This indicator is turned off only at the end of each program cycle; thus it is on during both detail and total operations. Detail and total operations conditioned by the record identifying indicator, currently on, will then be performed.

Figure 1-14 shows specific steps in the RPG II logic related to record identifying indicators.

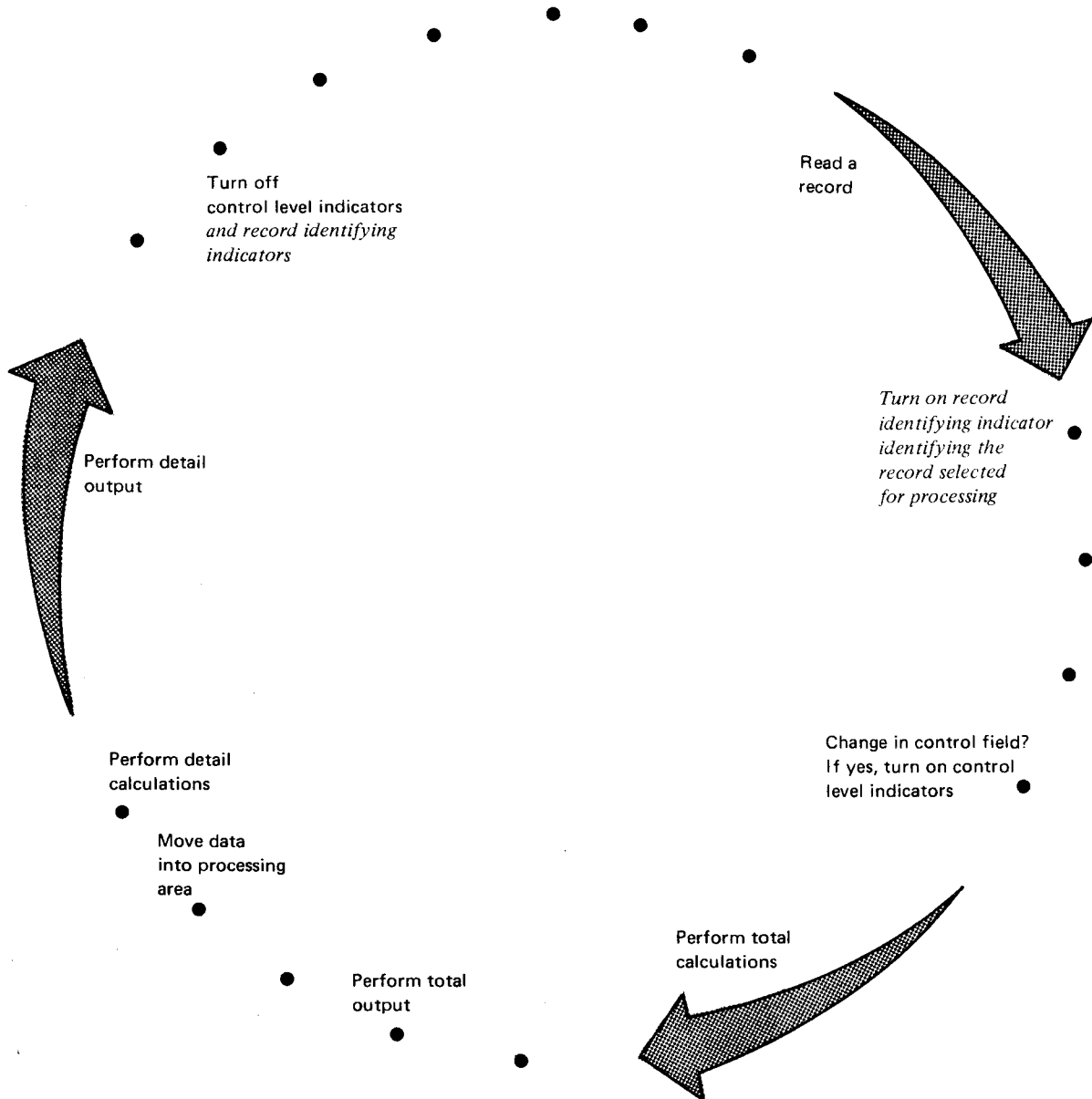

Figure 1-14. Logic for Record Identifying Indicators





### RPG CALCULATION SPECIFICATIONS

Form GX21-9093  
Printed in U.S.A.

Program		Punching Instruction	Graphic	Card Electro Number
Programmer	Date	Punch		

Page 1 of 2 Program Identification 75 76 77 78 79 80

Line	Form Type	Control Level (L/O/L)	Indicators				Factor 1	Operation	Factor 2	Result Field		Resulting Indicators			Comments
			And	And	Not	Not				Name	Length	Plus	Minus	Zero	
01	C		20				BALFOR	ADD	PURCHS	BALFOR					
02	C		30				BALFOR	SUB	PAYMNT	BALFOR					
03	C														
04	C														

### RPG OUTPUT SPECIFICATIONS

Form GX21-9090 UJM 050\*  
Printed in U.S.A.

Program		Punching Instruction	Graphic	Card Electro Number
Programmer	Date	Punch		

Page 1 of 2 Program Identification 75 76 77 78 79 80

Line	Form Type	Filename	Type (H/D/T/E)				Space	Skip	Output Indicators			Field Name	End Position in Output Record	P/B/L/R
			Before	After	Not	Not			Not					
01	O	REPORT	D			306								
02	O										NUM	15		
03	O										NAME	45		
04	O										BALFORA	60		
05	O		D			1					PURCHS1	20		
06	O													
07	O		D			1					PAYMNT1	40		
08	O													
09	O		T			12					BALFORA	60		
10	O													
11	O											61	*	

Commas	Zero Balances to Print	No Sign	CR	-	X = Remove Plus Sign
Yes	Yes	1	A	J	Y = Date
Yes	No	2	B	K	Z = Zero Suppress
No	Yes	3	C	L	
No	No	4	D	M	

Constant or Edit Word

Figure 1-16 (Part 2 of 2). Billing Job Specifications Using Record Identifying Indicators

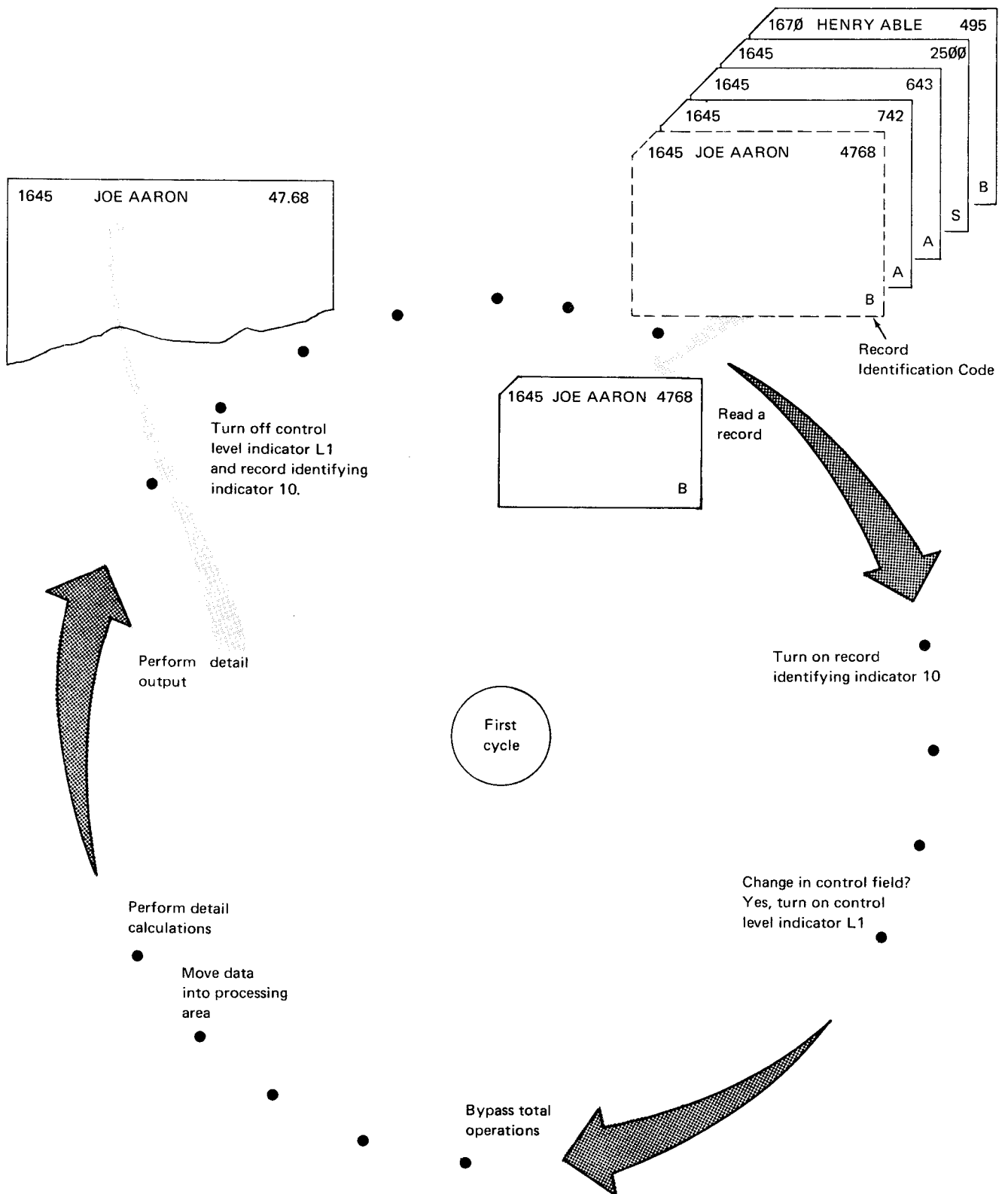

Figure 1-17 (Part 1 of 3). Program Cycle Illustrating Use of Record Identifying Indicators

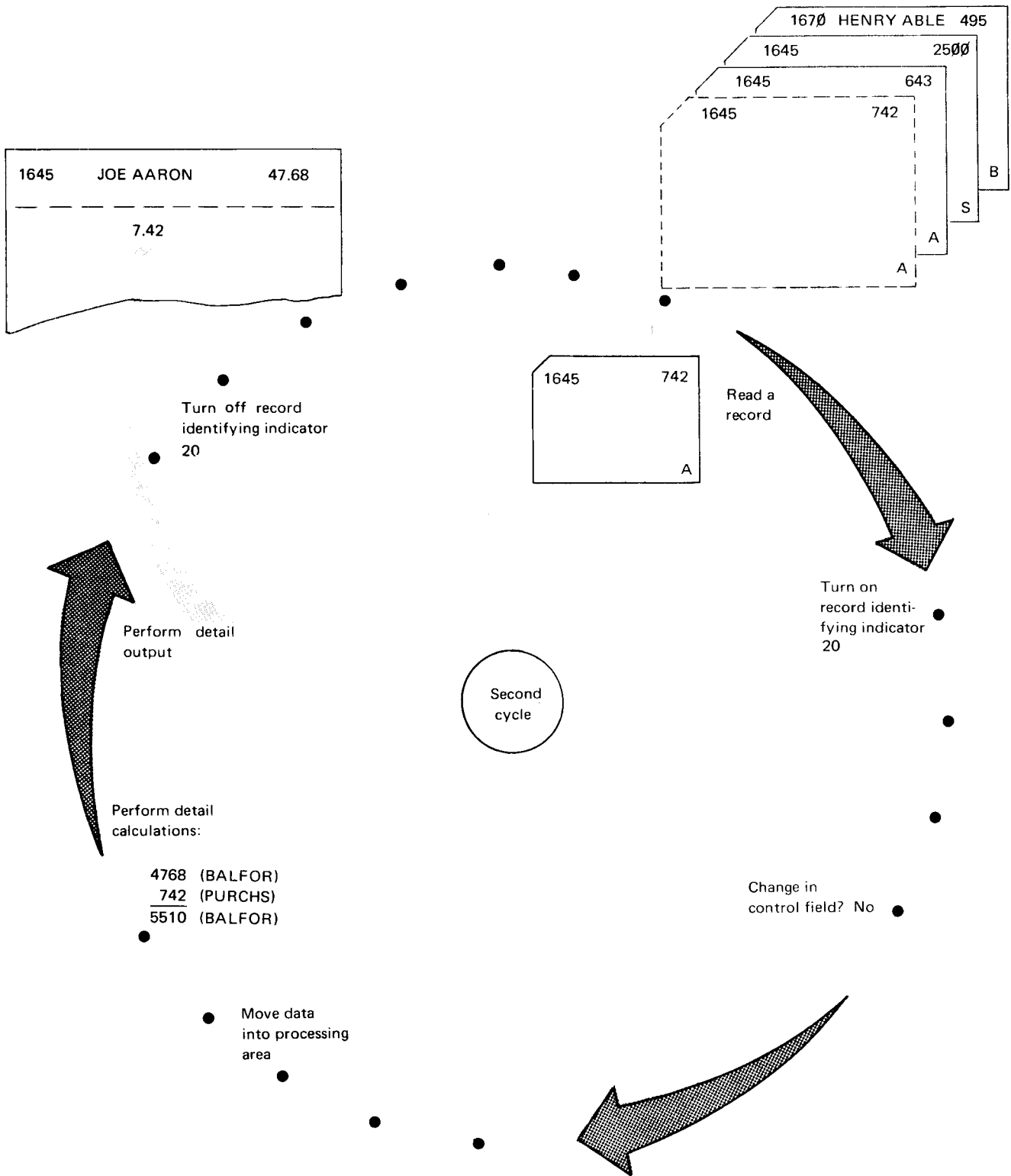

Figure 1-17 (Part 2 of 3). Program Cycle Illustrating Use of Record Identifying Indicators

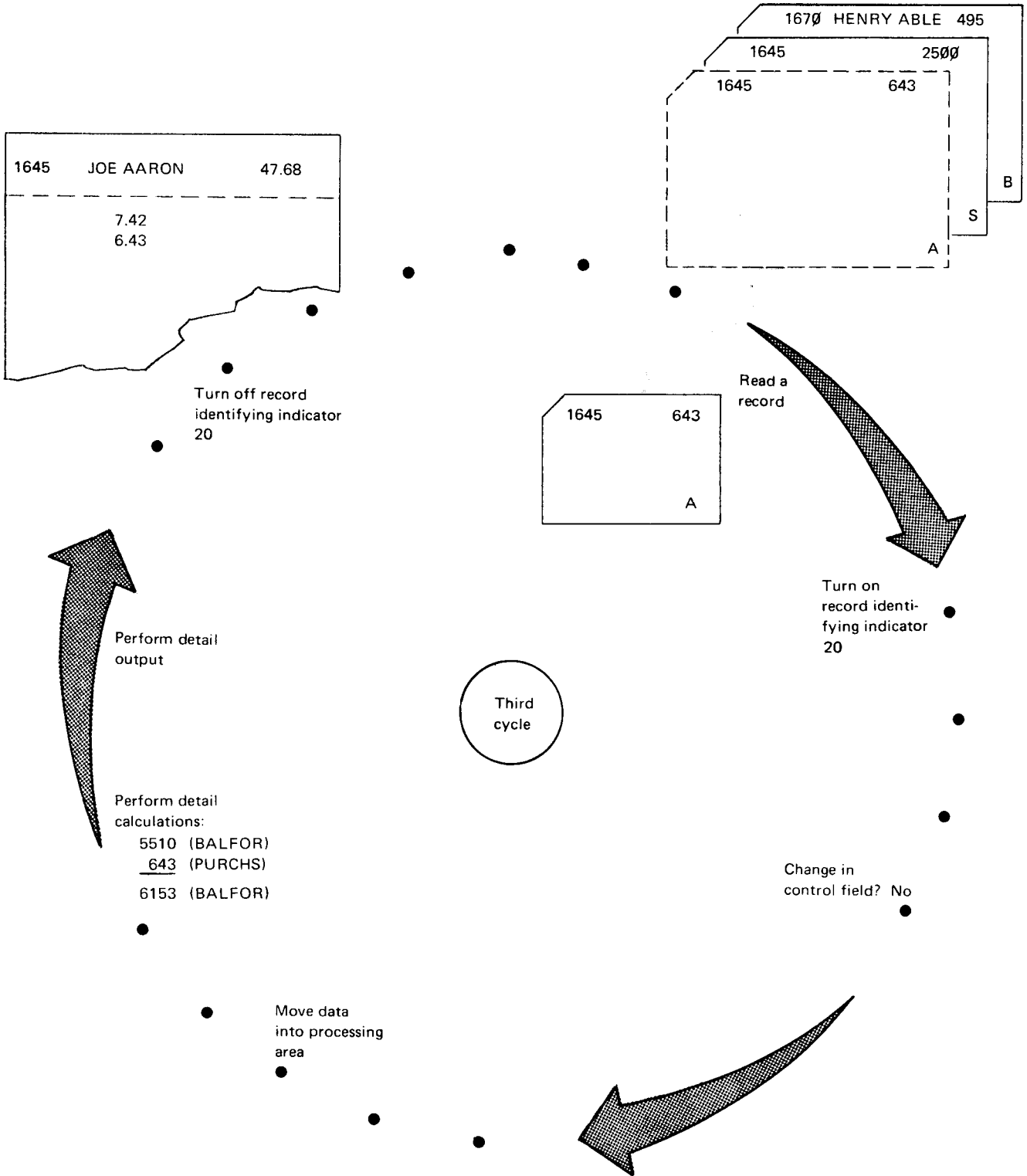

Figure 1-17 (Part 3 of 3). Program Cycle Illustrating Use of Record Identifying Indicators

**Field Indicators (01-99)**

Field indicators are used to test a field on an input record for a plus, minus, zero or blank value. Any operations that are to be performed only when a numeric field is plus, minus, or zero or when an alphameric field is blank may be conditioned by the appropriate field indicator.

*Note:* A numeric field that is all blanks will turn on an indicator specified for all zeros. However, if an alphameric field is all zeros, the field will not turn on an indicator specified for all blanks.

Field indicators are turned on or off after data from the record to be processed has been moved into the processing area. Figure 1-18 shows the RPG II logic related to field indicators.

For each program cycle, field indicators are set to reflect the result of the test on a field. If the condition tested for is satisfied, they are turned on; if the condition is not satisfied, they are turned off. A field indicator that is set as the result of a test retains its setting until another test is made using the same indicator.

When the indicator is on, any detail and total operations conditioned by the field indicator may be performed before testing of a field again resets the indicator. Remember that at total time, however, the field indicator will have the setting established in the *previous* cycle.

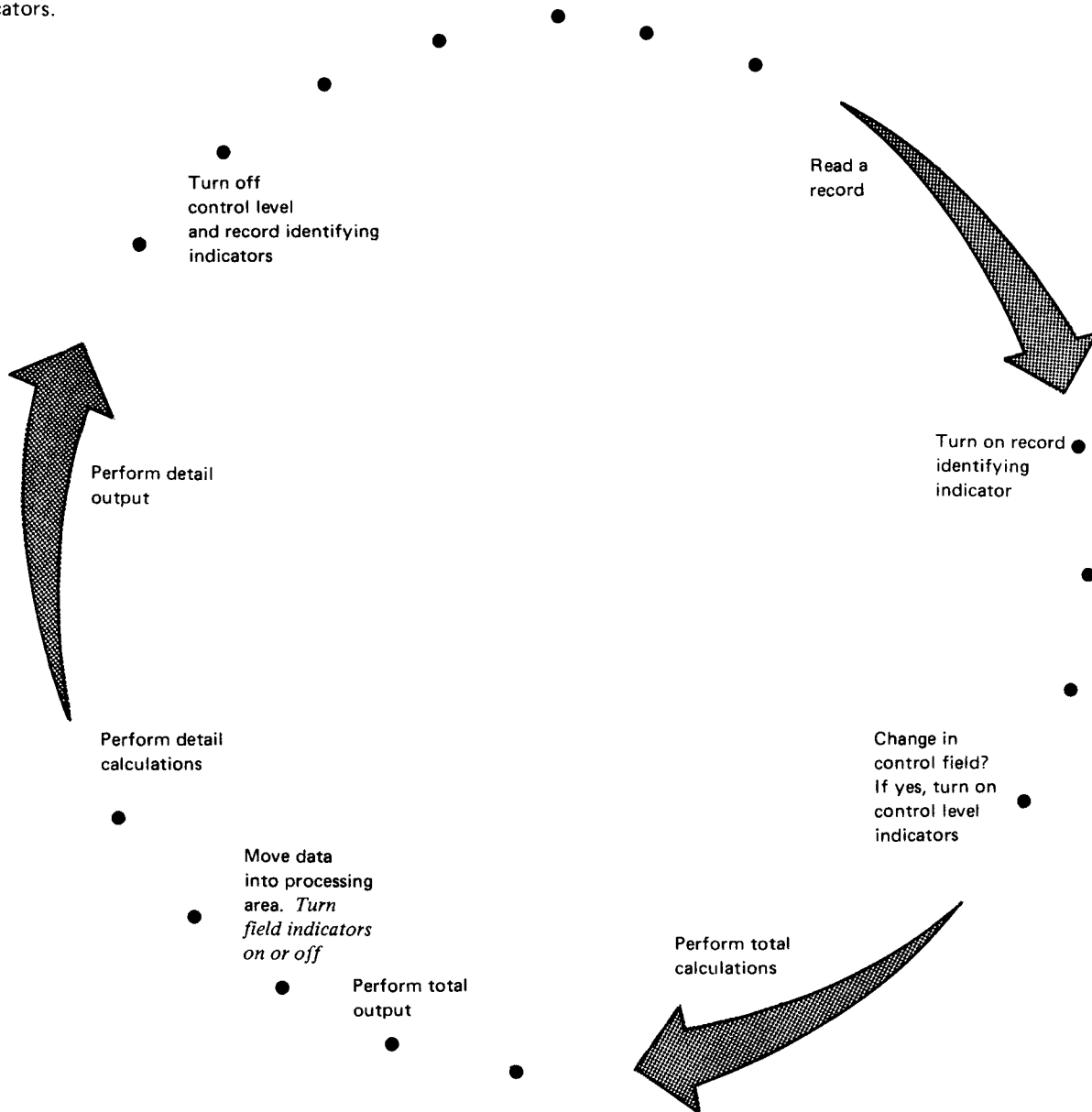

**Figure 1-18. Logic for Field Indicators**

Consider the use of field indicators in the billing job previously described. The same record types are used as in the previous job. The only difference is the additional field, discount (DISCRT), in columns 39-40 on the balance forward record.

Each time a record with a B in position 96 is read, DISCRT must be tested. Only when it contains a positive value should discount be calculated. Figure 1-19 shows the input, calculation, and output-format specifications for this job.

All employees receive a discount on everything they buy. The rate of discount they receive is recorded in the DISCRT field. All accounts other than employee accounts have a zero in the discount field since they receive no discount.

Use these specifications to help you follow, step by step, the logic for each program cycle shown in Figure 1-20.

I		Form Type		Sequence		Number (LN)		Date (O)		Record Identifying Indicator		Record Identification Codes			Field Location		Field Name		Control Level (L,L,L)		Matching Fields or Chaining Fields		Field Record Relation		Field Indicators		
Line												1	2	3	From	To							Plus	Minus	Zero or Blank		
01	I	B	I	L	L	I	0	1	0						1	7	NUM										
02	I														8	30	NAME										
03	I																										
04	I														31	382	BAL FOR										
05	I														39	402	DISCRT						99				
06	I																										
07	I														1	7	NUM										
08	I														8	30	NAME										
09	I																										
10	I														31	382	PURCHS										
11	I																										
12	I														1	7	NUM										
13	I														8	30	NAME										
14	I														31	382	PAYMNT										

Figure 1-19 (Part 1 of 2). Billing Job Specifications Using Field Indicators

**IBM** International Business Machine Corporation Form GX21-9093  
Printed in U.S.A.

**RPG CALCULATION SPECIFICATIONS**

Program		Punching Instruction		Graphic		Card Electro Number		Page 1 2 of		Program Identification 75 76 77 78 79 80	
Programmer		Date		Punch							

Line	Form Type	Indicators			Factor 1	Operation	Factor 2	Result Field		Comments
		And	And	Not				Name	Length	
0 1	C	99	20		PURCHS	MULT	DISCRT	DISC	42H	
0 2	C	99	20		PURCHS	SUB	DISC	PURCHS		
0 3	C		20		BALFOR	ADD	PURCHS	BALFOR		
0 4	C		30		BALFOR	SUB	PAYMNT	BALFOR		

**IBM** International Business Machine Corporation Form GX21-9090 U/M 050\*  
Printed in U.S.A.

**RPG OUTPUT SPECIFICATIONS**

Program		Punching Instruction		Graphic		Card Electro Number		Page 1 2 of		Program Identification 75 76 77 78 79 80	
Programmer		Date		Punch							

Line	Form Type	Filename	Space		Output Indicators			Field Name	End Position in Output Record
			Before	After	And	And	Not		
0 1	O	REPORT	D	306			10		
0 2	O						NUM	15	
0 3	O						NAME	45	
0 4	O						BALFORA	60	
0 5	O		D	1					
0 6	O						PURCHSL	20	
0 7	O		D	1					
0 8	O						PAYMNTL	40	
0 9	O		T	12					
1 0	O						BALFORA	60	

Figure 1-19 (Part 2 of 2). Billing Job Specifications Using Field Indicators



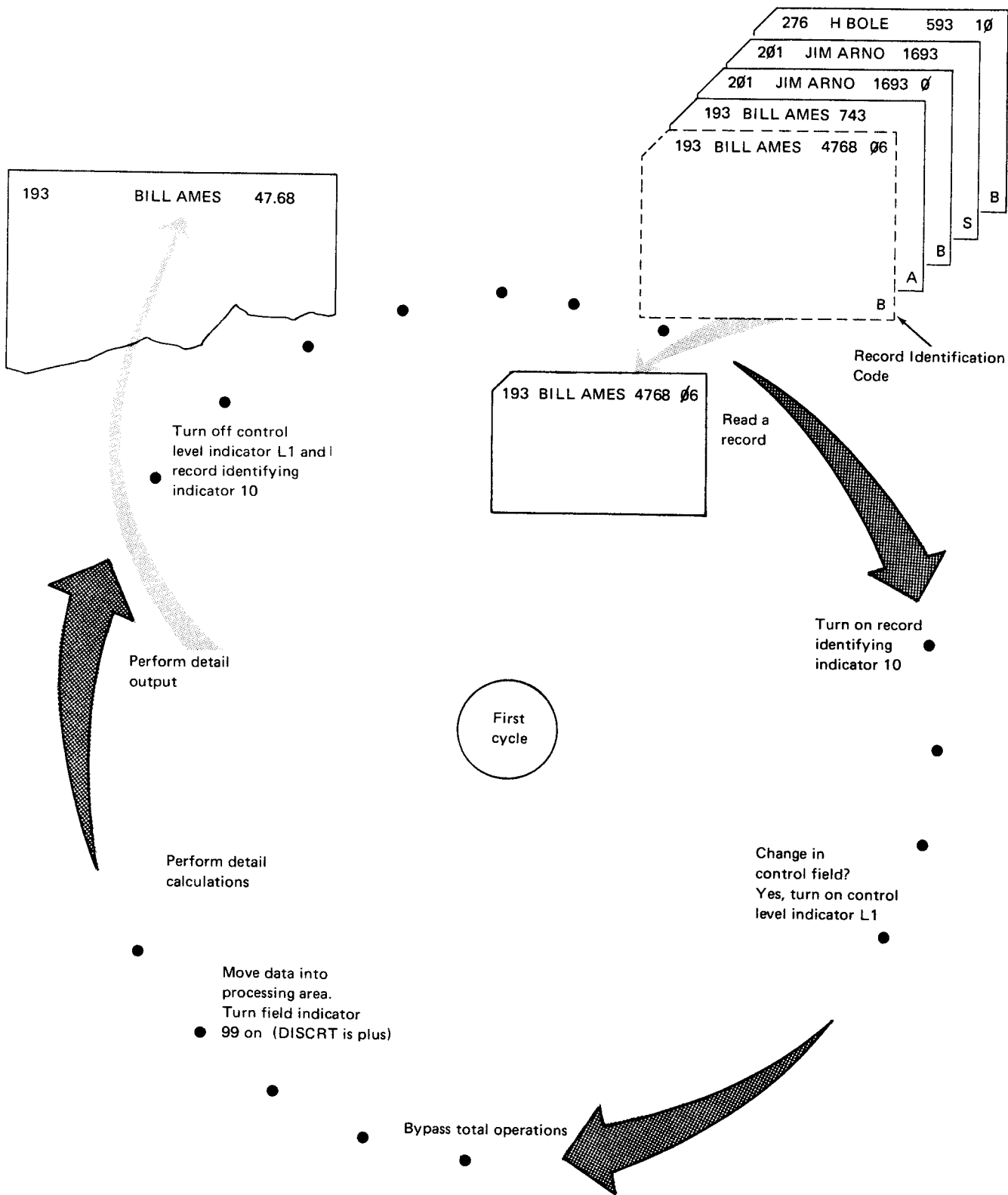

Figure 1-20 (Part 1 of 3). Program Cycles Illustrating Use of Field Indicators

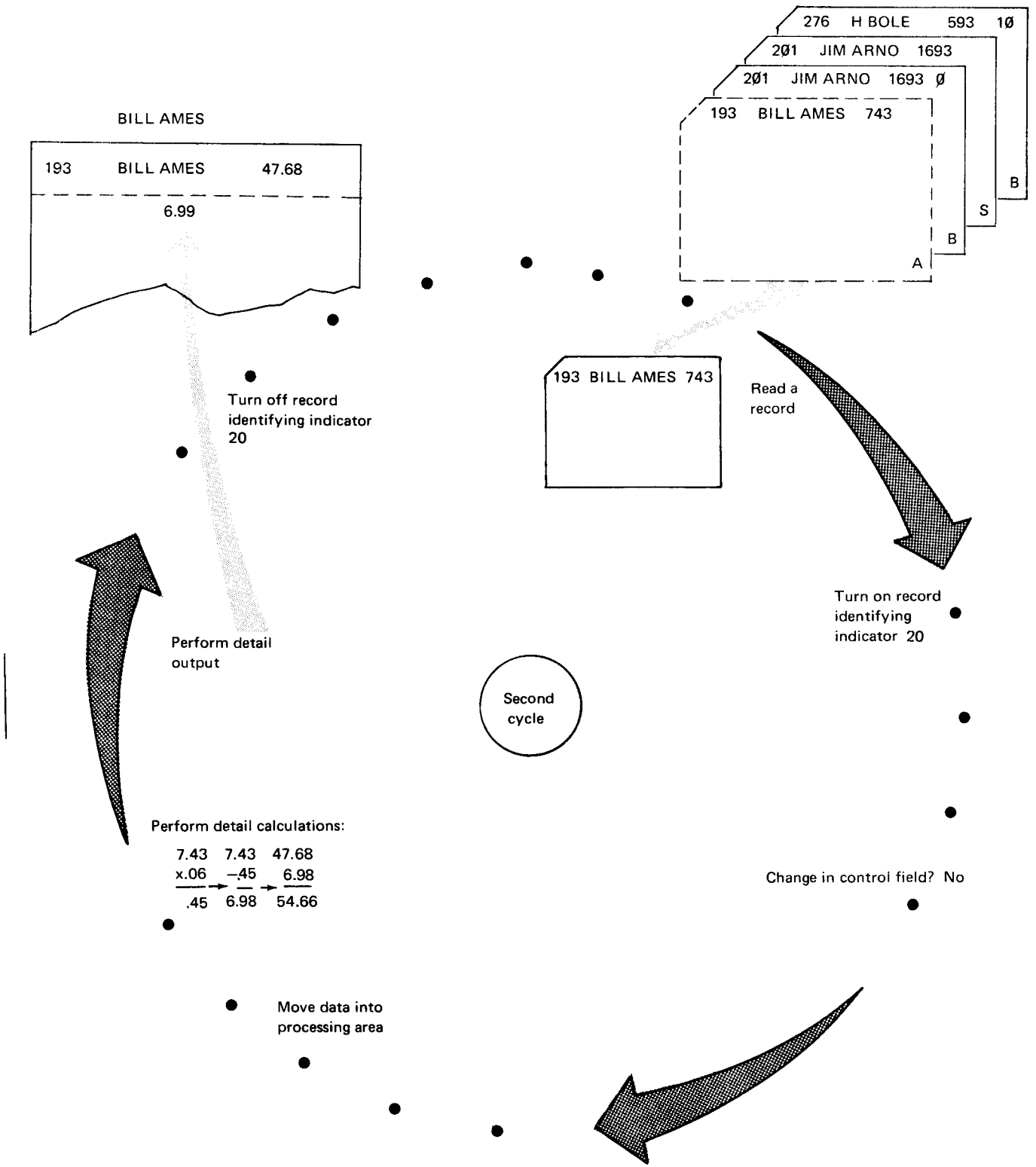

Figure 1-20 (Part 2 of 3). Program Cycles Illustrating Use of Field Indicators

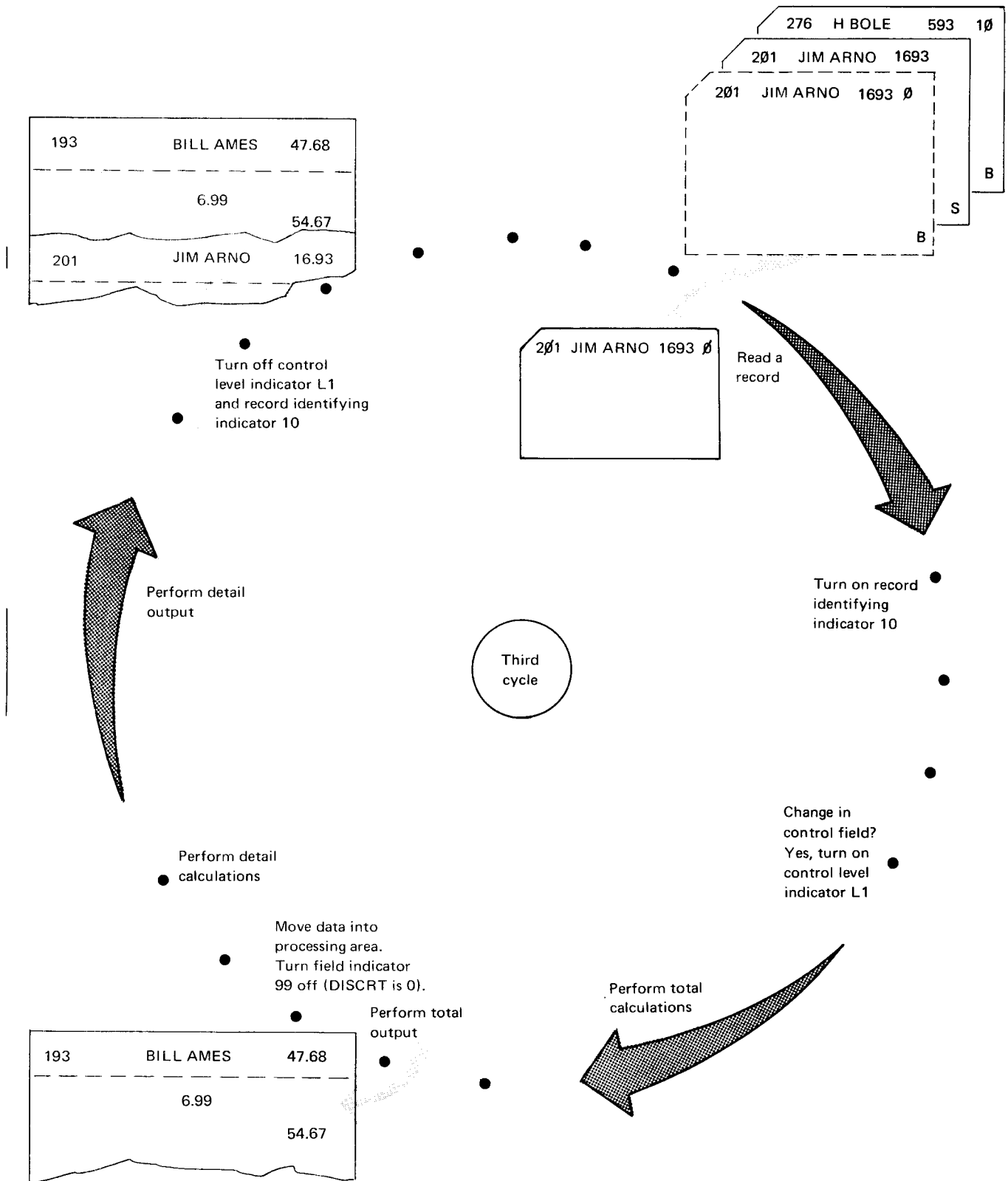

Figure 1-20 (Part 3 of 3). Program Cycles Illustrating Use of Field Indicators

**Resulting Indicators (01-99)**

Resulting indicators are assigned to signal something about the result of a calculation operation. Any operation which is dependent upon the result of the calculation can then be conditioned by a resulting indicator.

Resulting indicators may be turned on or off at either detail or total calculation time. An indicator which is set as a result of the calculation operation retains this setting until the next time a calculation is done for which the same indicator is a resulting indicator and the condition is not satisfied. Figure 1-21 shows the RPG II logic related to resulting indicators.

A resulting indicator may change status in the same cycle. This happens when *one* indicator is assigned to signal the result of both a total and detail calculation. The total calculation could turn it off and the detail calculation could turn it on, or vice versa. The indicator will not, however, be reset to show that a field is blank or zero after being blanked out by the Blank After function (B in column 39 of the Output-Format sheet).

The use of resulting indicators is demonstrated by an inventory job which determines whether an item needs to be reordered. After inventory has been taken, the quantity on hand is recorded for each item. If the quantity on hand is 100 or less, reorder should be immediate. If the quantity

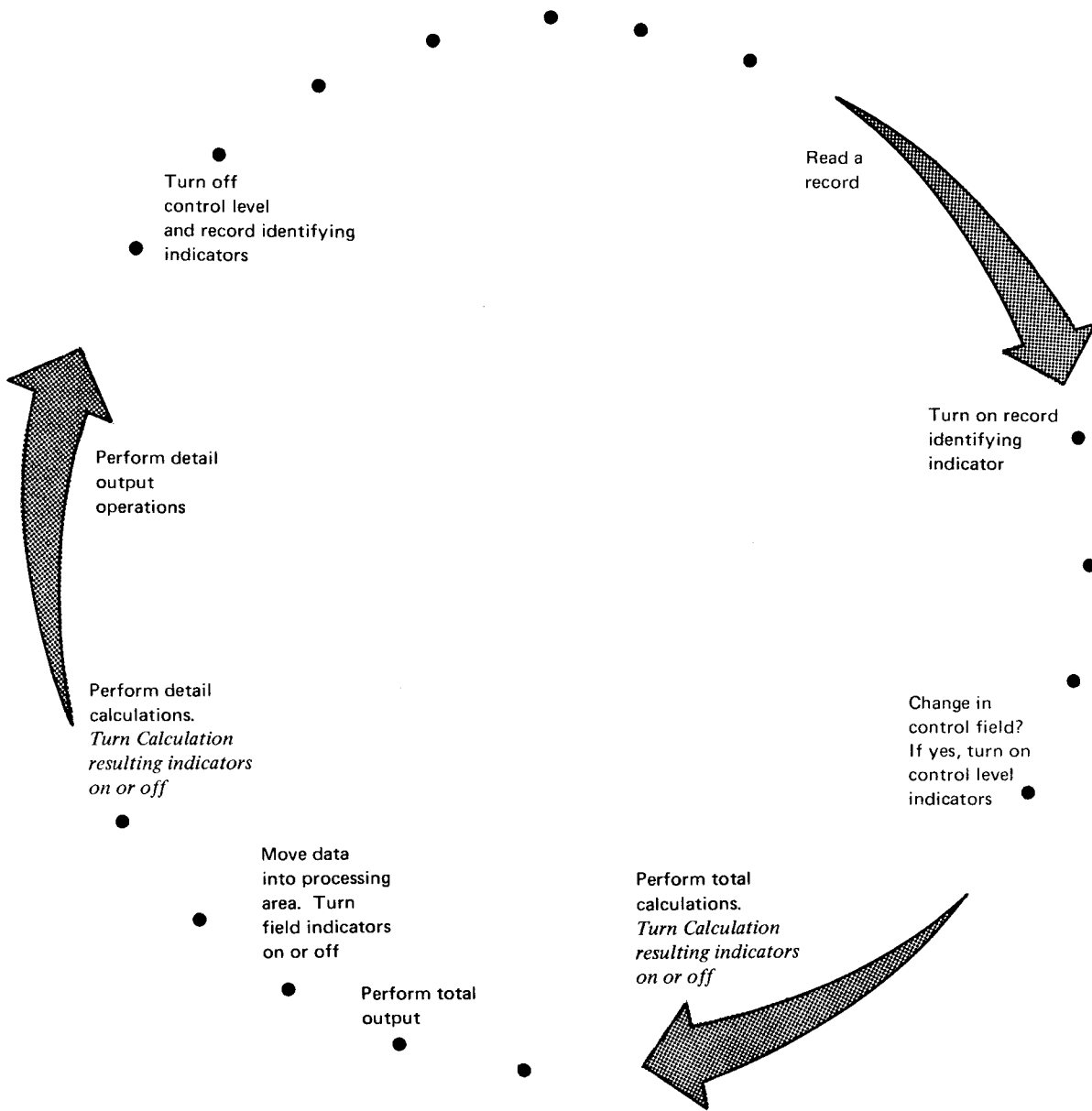

Figure 1-21. Logic for Resulting Indicators

is over 100, the item need not be reordered at this time. A list of all items is printed. All items to be reordered are indicated with a double asterisk. Figure 1-22 shows the specifications for the job. Use these specifications to help you follow the program cycles shown in Figure 1-23.

### RPG INPUT SPECIFICATIONS

GX21-9094 U/M 050\*  
Printed in U.S.A.

Program		Punching Instruction	Graphic	Card Electro Number	Page 1 2 of	Program Identification
Programmer		Date	Punch			75 76 77 78 79 80

Line	Form Type	Filename	Sequence Number (1,N)	Option (D)	Record Identifying Indicator	Record Identification Codes									Field Location		Field Name	Control Level (1,1,9)	Matching Fields or Chaining Fields	Field Record Relation	Field Indicators			
						1	2	3	4	5	6	7	8	9	10	11					12	From	To	Plus
01	I	INVEN	AB	01												1	10	ITEM						
02	I															11	31	DESC						
03	I															32	35	QTY						
04	I																							
05	I																							

### RPG CALCULATION SPECIFICATIONS

Form GX21-9093  
Printed in U.S.A.

Program		Punching Instruction	Graphic	Card Electro Number	Page 1 2 of	Program Identification
Programmer		Date	Punch			75 76 77 78 79 80

Line	Form Type	Indicators	Factor 1	Operation	Factor 2	Result Field		Resulting Indicators	Comments
						Name	Length		
01	C		QTY	COMP	L00			36	
02	C								

### RPG OUTPUT SPECIFICATIONS

GX21-9090 U/M 050\*  
Printed in U.S.A.

Program		Punching Instruction	Graphic	Card Electro Number	Page 1 2 of	Program Identification
Programmer		Date	Punch			75 76 77 78 79 80

Line	Form Type	Filename	Type (H/D/T/E)	Space	Skip	Output Indicators			Field Name	End Position in Output Record	Constant or Edit Word
						And	And	And			
01	O	LIST	D	2					*AUTO	14	***
02	O									25	
03	O									50	
04	O										
05	O										

Figure 1-22. Inventory Job Specifications Using Resulting Indicators

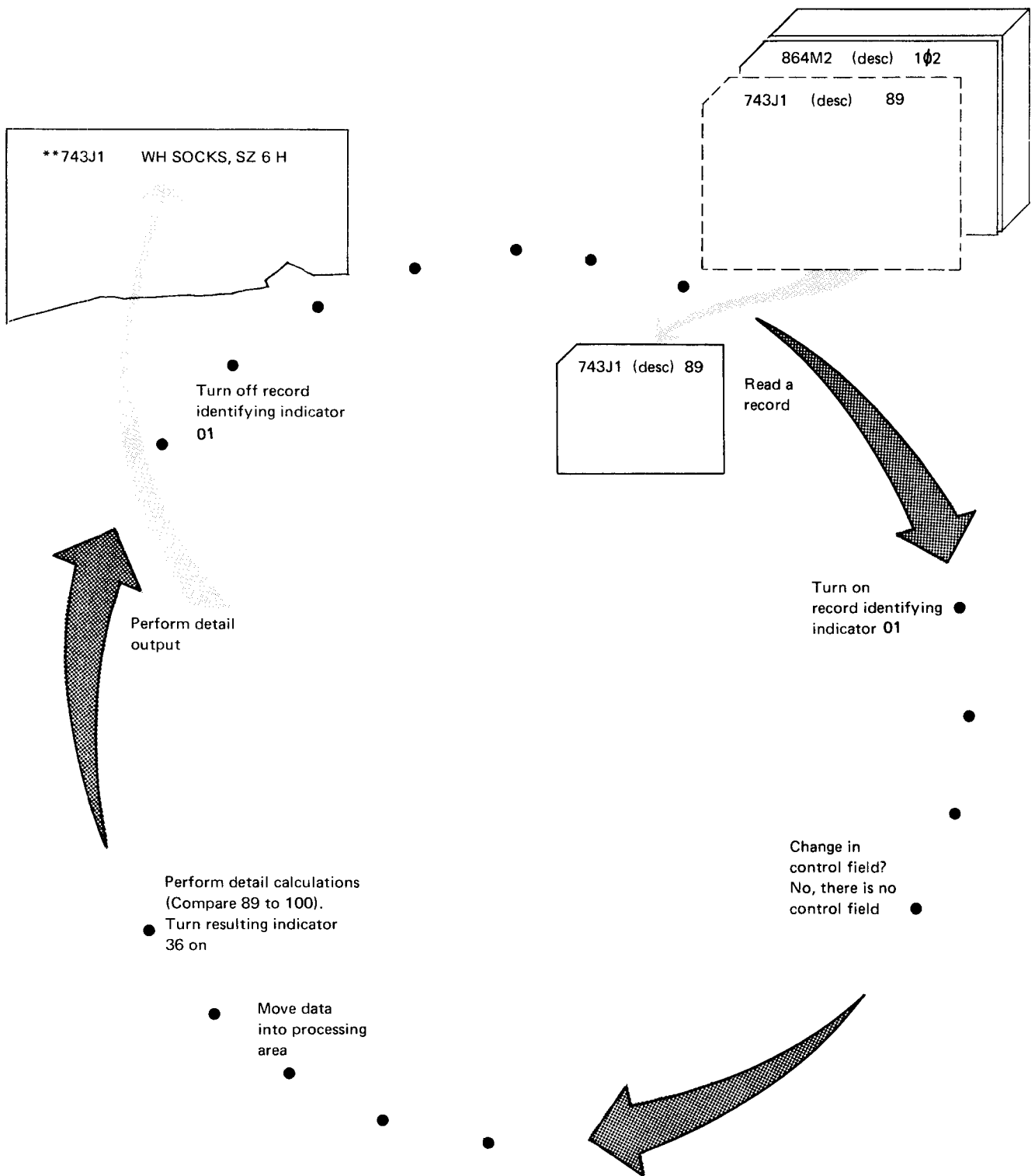

Figure 1-23 (Part 1 of 2). Program Cycles Illustrating Use of Resulting Indicators

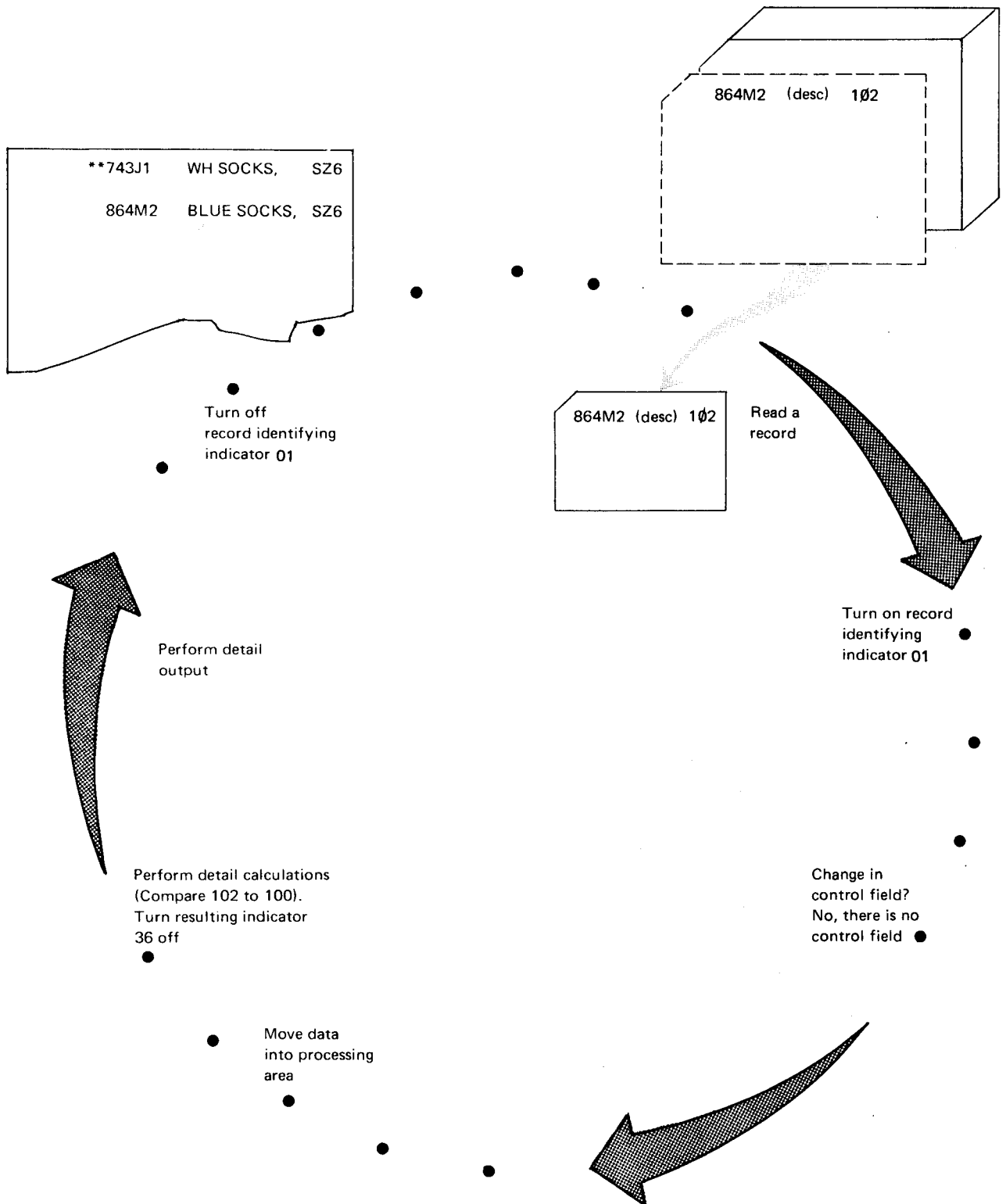

Figure 1-23 (Part 2 of 2). Program Cycles Illustrating Use of Resulting Indicators

## Halt Indicators (H1-H9)

Halt indicators are used to stop the program when a specified condition is satisfied. Halt indicators may be used as record identifying, field, or resulting indicators. When halt indicators are used as record identifying indicators, a halt will be caused by a specific type of record; when used as field indicators, a halt will be caused by erroneous input data; when used as resulting indicators, a halt will be caused by erroneous results from calculations.

A halt indicator may be turned on at one of four different times (see Figure 1-24). Its use, of course, will determine when it is turned on. The program does not halt immediately when a halt indicator is turned on. All total and detail operations remaining in the cycle are performed first; then the program halts. This means that processing will still be completed on information from the record that caused the error condition.

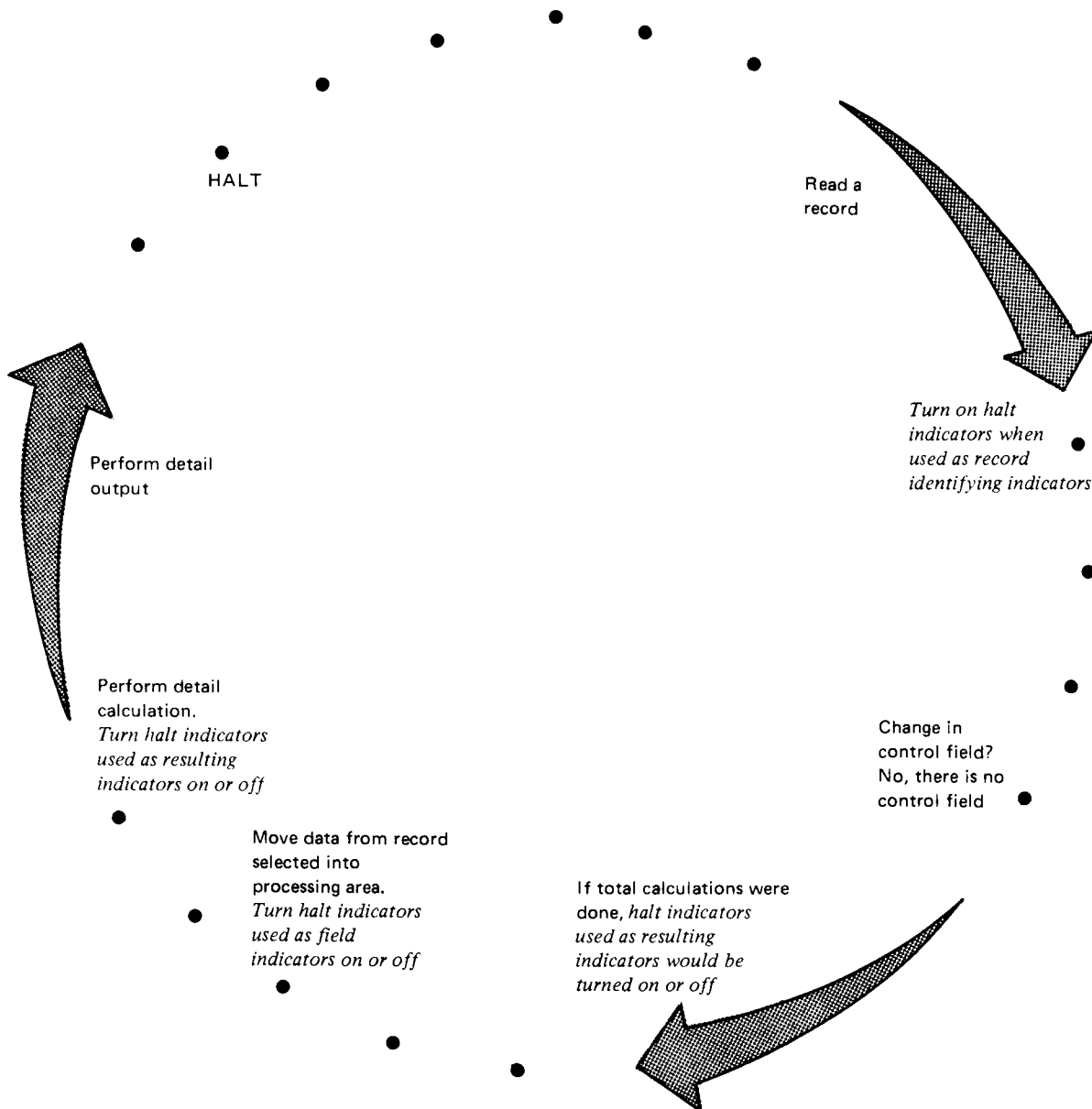

Figure 1-24. Logic for Halt Indicators







Figure 1-26 shows the three program cycles. In the first cycle there is no error. In the second, a halt occurs because of a blank number field. The third begins with another record being read.

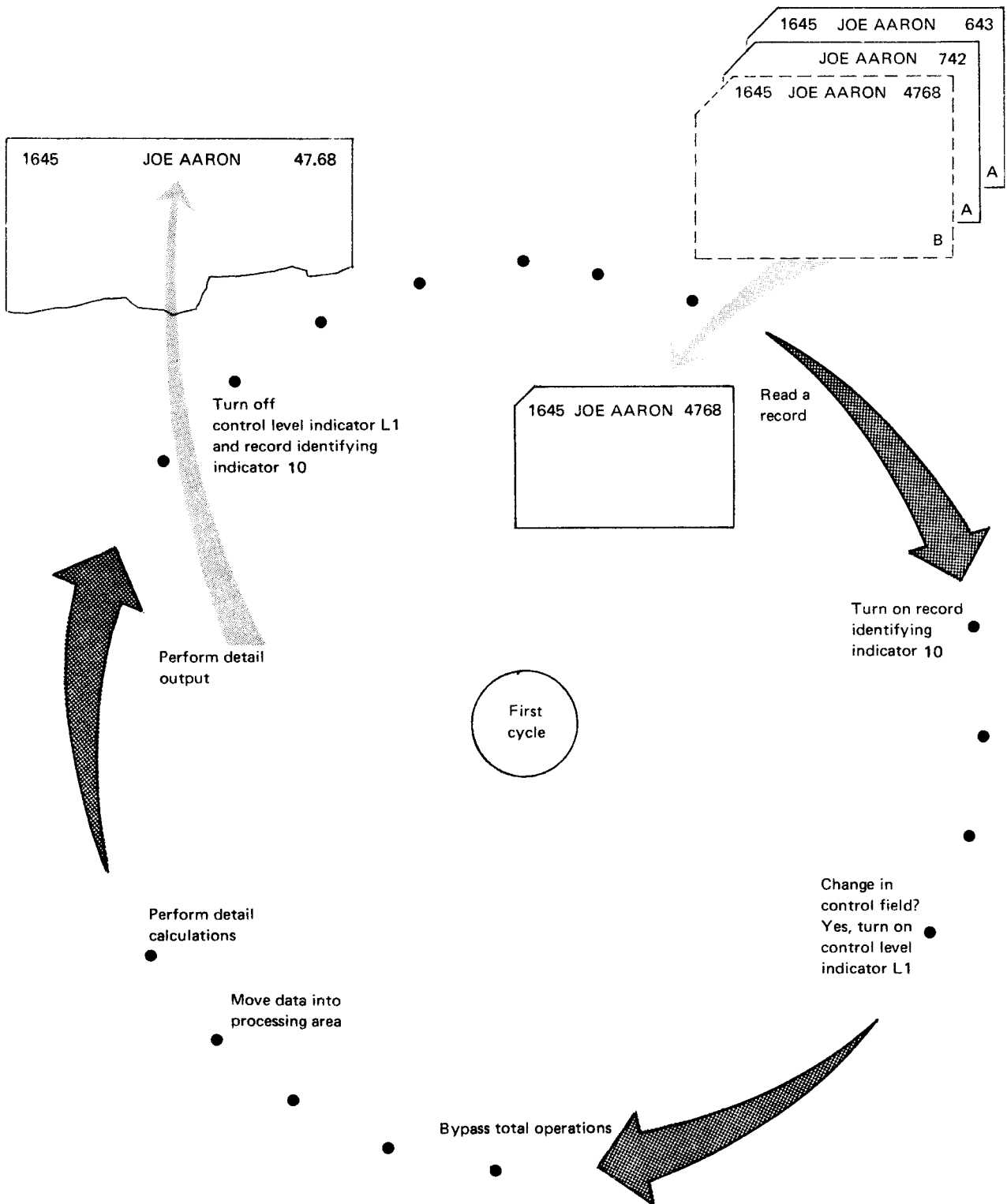

Figure 1-26 (Part 1 of 3). Program Cycles Illustrating Use of Halt Indicators

The second cycle shows that operations are performed on the record that contains the blank NUM field. The record containing an amount of 742 has a blank account number field. Thus it is not known whether this record really belongs to Joe Aaron. But Joe is charged 742, regardless,

since detail operations are performed before the halt occurs. In order to prevent processing data which could be in error, you must write specifications which will bypass operations when an error occurs. This will be discussed later in the chapter titled *Controlling Operations in an RPG II Program*.

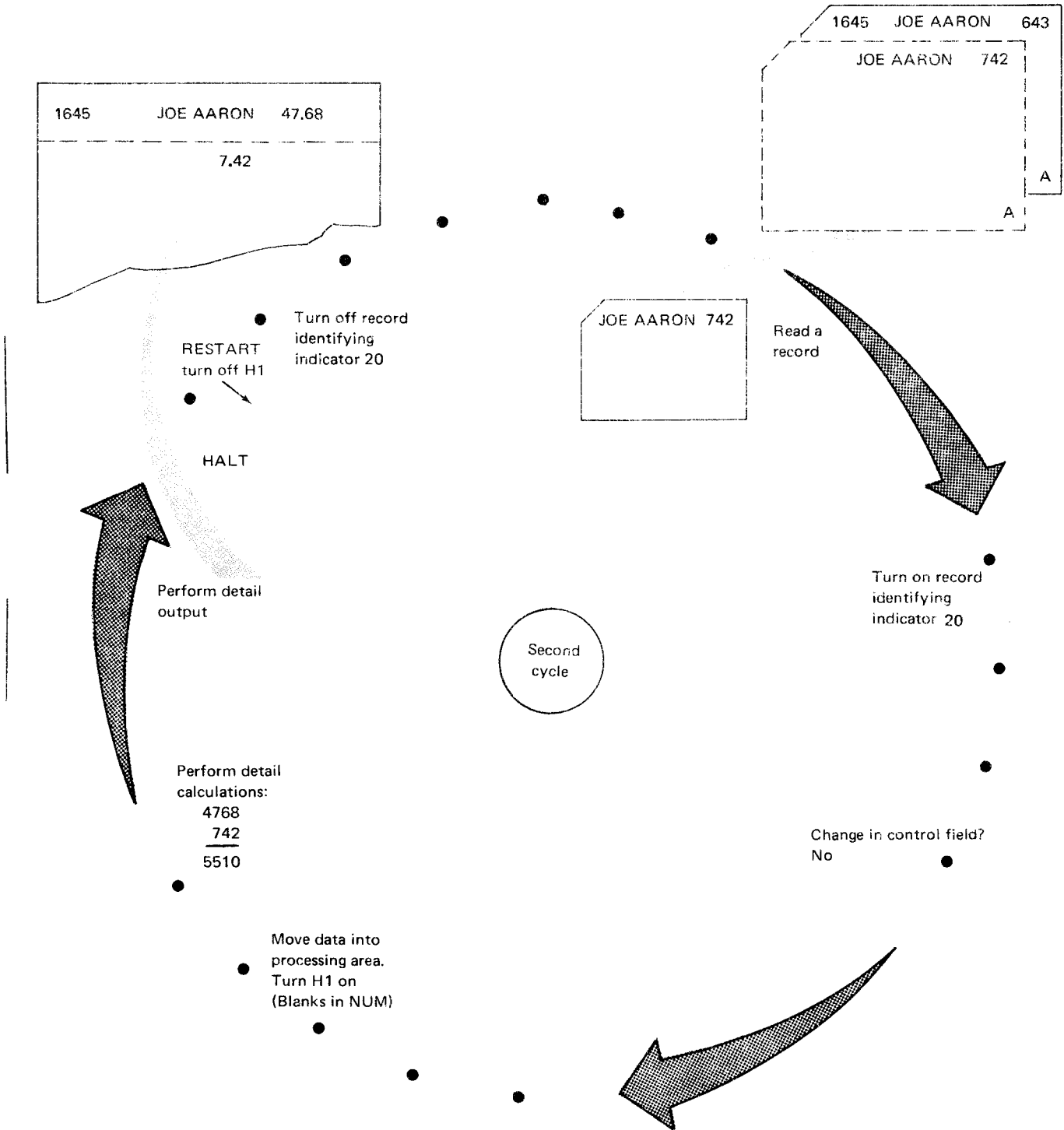

Figure 1-26 (Part 2 of 3). Program Cycles Illustrating Use of Halt Indicators

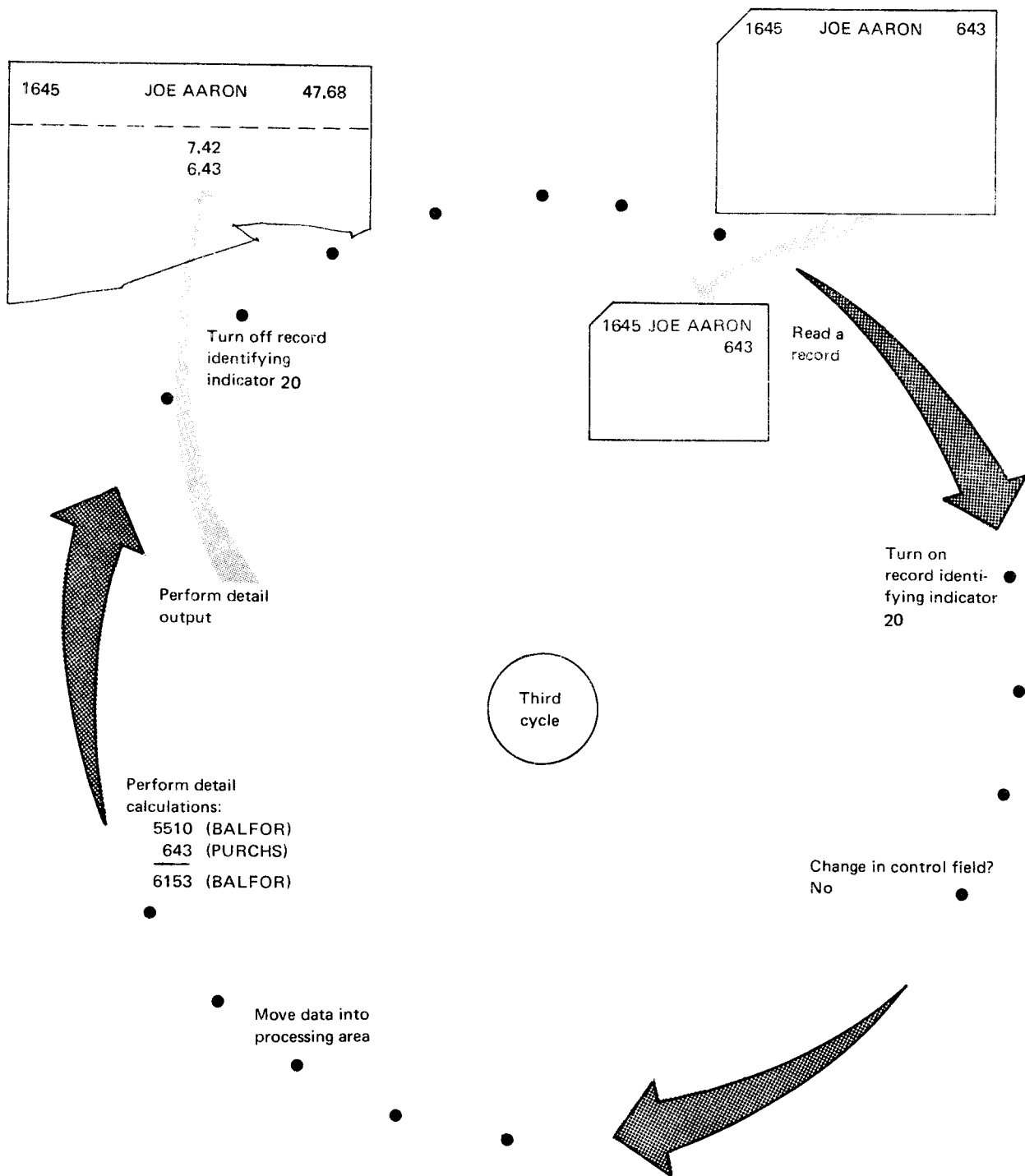

Figure 1-26 (Part 3 of 3). Program Cycles Illustrating Use of Halt Indicators

**Overflow Indicator (OA-OG, OV)**

Overflow indicators are used to signal when the end of a printed page has been reached. They are assigned to the printer file and turn on when the overflow line is printed. This could be either at detail or total output time. Those lines which you wish to print at the end of one page or at the beginning of another are conditioned by the overflow indicator.

Figure 1-27 shows RPG II logic related to overflow indicators. A more detailed discussion of the purpose and use of overflow indicators can be found in the chapter titled *Controlling Printer Output*.

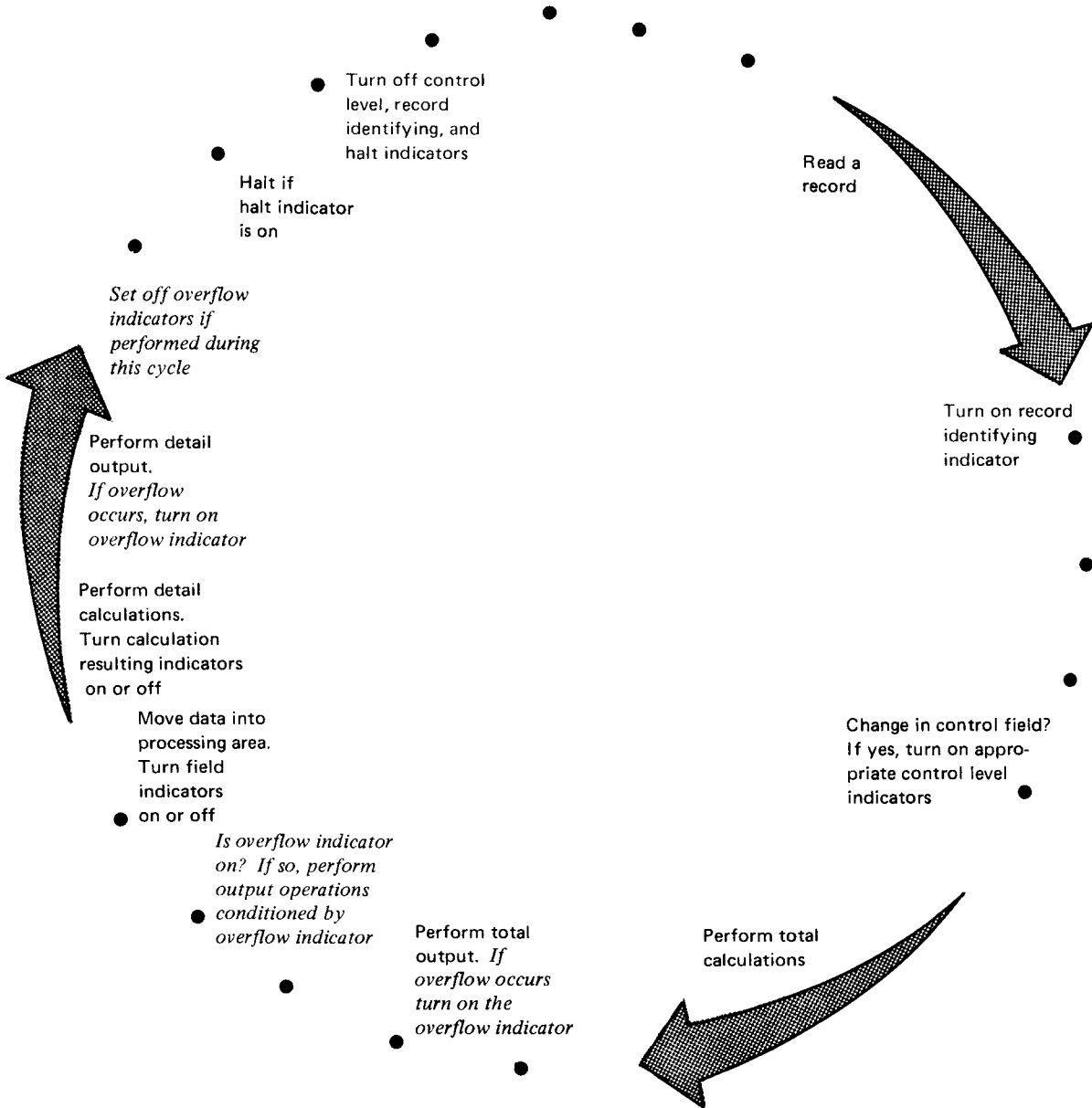

Figure 1-27. Logic for Overflow Indicators

## Matching Records Indicator (MR)

Thus far, you have been concerned with only one input file. According to RPG II logic discussed so far, a record is read from the input file, then processed. Another is read and processed and so on. Suppose you have more than one input file; from which file is a record read?

RPG II logic has been designed so that your program can select the next record for processing. Figure 1-28 shows general steps in the logic (multifile logic) required when more than one input file is used.

The matching record indicator (MR) is used only when you are processing more than one input file. It indicates when fields on records from different files match. MR is set only after total operations are performed. Thus, at detail time, MR always signals the matching status of the record just selected for processing; at total time, it reflects the matching status of the previous record.

Specific steps in the multi-file logic are described in the chapter titled *Match Fields and Multifile Processing*. At this time, it is sufficient to know at what point in the program cycle records are selected for processing and at what point MR is turned on.

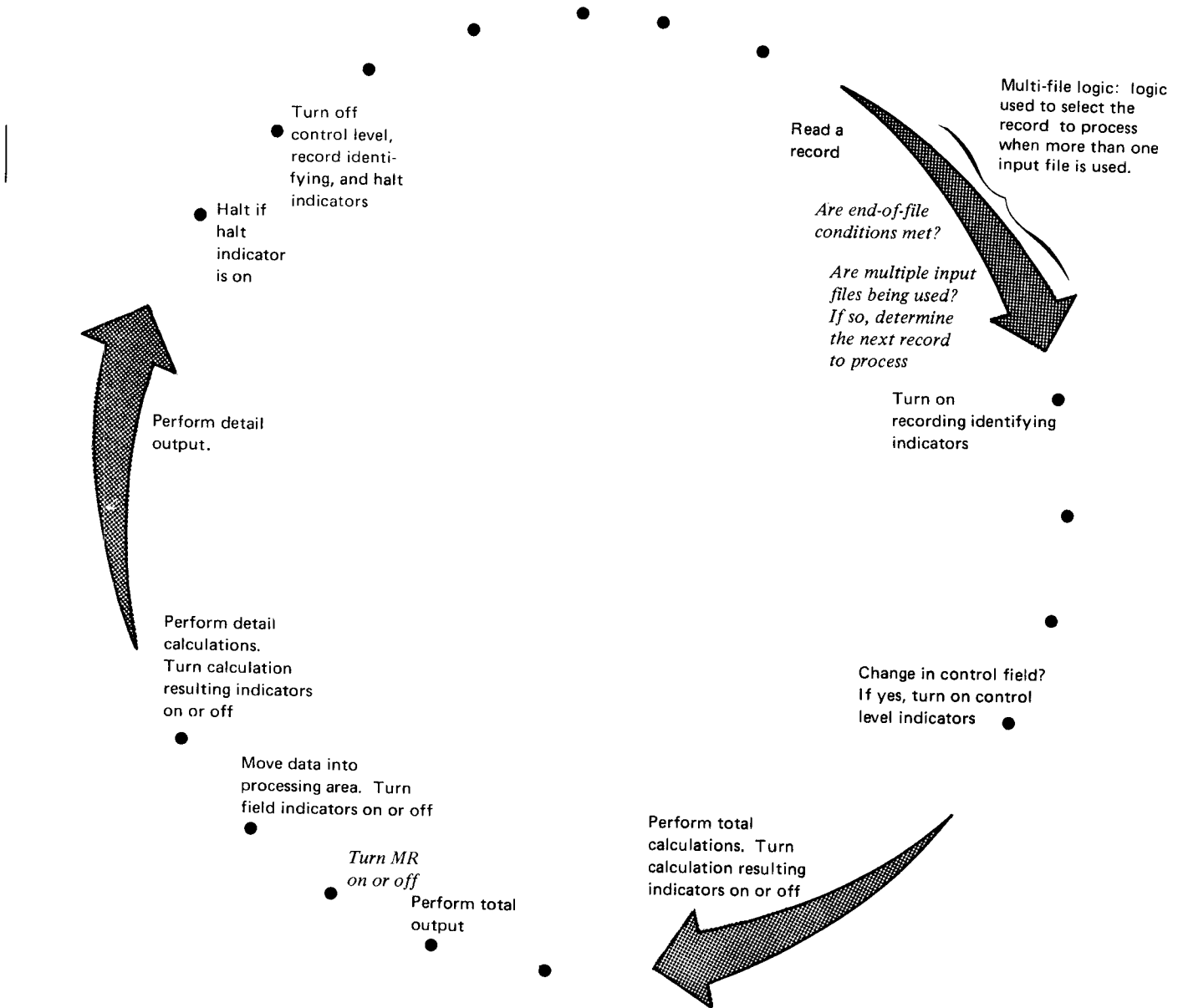

Figure 1-28. Simplified Matching Record Logic

## Setting Indicators

You have just seen the normal setting of indicators according to RPG II logic. You, in your program, can alter this setting by turning any indicator (except 1P) on or off through use of the operation codes SETON and SETOF (see Figure 1-29). An indicator may be set during either detail or total time. It will be set at the time the SETON or SETOF code is executed and will retain the setting you give it until it is reset according to the program logic. (Refer to the logic for the various indicators, earlier in this section, to determine when they are set on and off in the logic cycle.)

Indicators of various types may be used anywhere in the program. For example, you can use LR as a record identifying indicator, L1-L9 as resulting indicators, or L1-L9 as record identifying indicators. If you need to set indicators yourself, you should be thoroughly familiar with RPG II program logic so that you will use the indicators correctly in your program.

IBM		International Business Machine Corporation		RPG CALCULATION SPECIFICATIONS																																	Form GX21-8093 Printed in U.S.A.					
Program					Punching Instruction					Graphic					Card Electro Number					Page 1 2 of		Program Identification 75 76 77 78 79 80																				
Programmer					Date					Punch																																
Line	Form Type	Control Level (L0-L9, L1-SR, AN(O))	Indicators			Factor 1	Operation	Factor 2	Result Field		Decimal Positions Half Adjust (H)	Resulting Indicators			Comments																											
			And	And	And				Name	Length		Arithmetic	Plus	Minus		Zero																										
3																																										
0 1	C						SETON					1012																														
0 2	C																																									
0 3	C	L1					SETOF					99																														
0 4	C																																									
0 5	C																																									

Figure 1-29. Setting Indicators





1. Arrange the following steps in the order they occur in the RPG II logic cycle starting with *Read a record*.
  - a. Read a record
  - b. Total output
  - c. Move data from input area to processing area
  - d. Detail calculations
  - e. Detail output
  - f. Total calculations
2. In the RPG II cycle, total calculations and total output are for data from:
  - a. the record just read
  - b. records read in previous RPG II cycles
3. When is the 1P indicator on? When is it turned off?
4. Which steps are bypassed during the first program cycle?
5. When the LR indicator comes on, the last program cycle ends after \_\_\_\_\_; therefore \_\_\_\_\_ operations are not performed when LR is on (/ \* record read).
6. When are record identifying indicators turned on? When are they turned off?
7. When are field indicators (the indicators which test the contents of an input field) turned on or off?
8. Halt indicators may be turned on at various times depending on how they are used. If a halt indicator is turned on, when does the computer stop?
9. Calculation resulting indicators are turned on during total or detail calculations. When are they turned off?

## Answers To Review 1

1. a, f, b, c, d, e
2. b
3. 1P is on at the beginning of the first program cycle only. It is turned off before the first record is read.
4. total calculations and total output
5. total output, detail
6. Record identifying indicators are turned on right after a record has been read and identified. They are turned off at the end of each RPG II cycle.
7. Field indicators are set just after data is moved from the input area to the processing area.
8. The computer halts after detail output.
9. Resulting indicators remain on until reset by another calculation.

**CHAPTER 2 DESCRIBES:**

Specifying and using control fields and split control fields.

Checking the sequence of record types.

Describing input record types using the OR relationship.

OR records with field record relation.

Field record relation with control fields.

Conditioning use of input files.

**BEFORE READING THIS CHAPTER YOU SHOULD BE ABLE TO DESCRIBE:**

Function and coding of input fields on the Input sheet.

Function of RPG II indicators.

RPG II object program cycle (Chapter 1).

**AFTER READING THIS CHAPTER YOU SHOULD BE ABLE TO DESCRIBE:**

Function and RPG II coding for control fields and split control fields.

How to handle typical record type sequence checking situations.

Function and RPG II coding for field record relation.

Uses for conditioning input files.

Setting external indicators.

*Note:* You can use the review questions contained in *Review 2* at the end of this chapter to test your comprehension of the topics in the chapter. Answers follow the review questions.

## INTRODUCTION

For every RPG II program, you must describe the input information you are processing. This includes describing input files, record types within each file, and fields within each record type. Input files are described on the File Description sheet; record types and fields within each input file are described on the Input sheet.

From previous instruction, reading, and experience, you should already know how to describe and use input files, record types, and fields. You should also know how to use RPG II indicators to condition operations. This chapter describes additional ways to use input with control level indicators, field record relation indicators, and external indicators.

## CONTROL FIELDS

A basic type of report in any data processing installation is a detail list that consists of one line of printing for each record read, such as a transaction listing. Figure 2-1 shows what a detail report would look like.

Because product classes are repeated for each line, the report is cluttered and hard to read. The same report (Figure 2-2) grouped by class is much easier to read. Here, all items from one class are listed together with headings used on each page to identify the information. Since all items on one page apply to the same class, the class is printed only once. Such a report is sometimes referred to as a *group-indicated* report. Group-indication is the printing of control information on one line per group. The date is printed at the bottom.

A *control field* is any field used to indicate when a certain type of processing should be done. Since the CLASS field (Figure 2-3) controls processing, it must be specified as the control field. Each time a record is read, this control field is checked for a change in contents (control break). When a control break occurs, a different type of processing or additional processing is to occur. In this case, a change in the CLASS field indicates:

1. Skip to the bottom of the page.
2. Print the date.
3. Skip to a new page.
4. Print heading.

CLASS	ITEM NO	DESCRIPTION	ON HAND
00124	7657352	SWEATER, V-NK, SZ 32	10
00124	63241B1	SWEATER, V-NK, SZ 34	16
00124	43151CK	CARDIGAN, SZ 36	17
	.	.	
	.	.	
00124	76738K2	CARDIGAN, SZ 40	8
00125	54321K4	T-SHIRT, WH, SZ 30	11
00125	56422K4	T-SHIRT, WH, SZ 32	14
00125	57381J4	T-SHIRT, WH, SZ 40	15
00125	58324B1	T-SHIRT, WH, SZ 42	8
	.	.	
	.	.	
00125	57421C2	T-SHIRT, BK, SZ 46	12
00126	67341B3	WOOL SOCKS, BL 10	11

IN STOCK AS OF 10/30/70

Figure 2-1. Printed Report of all Items in Stock

CLASS	ITEM NO	DESCRIPTION	ON HAND
00124	46732J1	SWEATER, V-NK, SZ 32	10
	63241B1	SWEATER, V-NK, SZ 34	16
	43151CK	CARDIGAN, SZ 36	17
	:	:	
IN STOCK AS OF 10/30/70			
CLASS	ITEM NO	DESCRIPTION	ON HAND
00125	54321K4	T-SHIRT, WH, SZ 30	11
	56422K4	T-SHIRT, WH, SZ 32	14
	57381J4	T-SHIRT, WH, SZ 40	15
	58324B1	T-SHIRT, WH, SZ 42	8
	:	:	
IN STOCK AS OF 10/30/70			
CLASS	ITEM NO	DESCRIPTION	ON HAND
00126	67341B3	WOOL SOCKS, BL 10	11
	67432B3	WOOL SOCKS, GR 10	9
	:	:	
IN STOCK AS OF 10/30/70			

Figure 2-2. Report Group - Indicated by Product Class

CLASS	ITEMNO	DESC	ONHAND	DATE	
1	5 6	12 13	32 33	38 39	44

Figure 2-3. Item Record

### Coding Control Fields

The RPG II specifications for the program are shown in Figure 2-4. The entry L1 on line 02 of the Input Sheet (Figure 2-4, insert A) establishes the CLASS field as a control field. When the information in the control field changes (a control break occurs) L1 is turned on. The L1

indicator is used on the Output-Format Sheet (Figure 2-4, insert B) to condition those operations which should be performed only when a control break occurs. Note that the L1 indicator is used in line 08 to condition the CLASS field in the detail output line. This causes the CLASS field to be printed only for the first record of a new control group. That is, the CLASS field is printed only when it changes.

**IBM** International Business Machine Corporation

Program: \_\_\_\_\_  
 Programmer: \_\_\_\_\_ Date: \_\_\_\_\_

### RPG INPUT SPECIFICATIONS

Punching Instruction: \_\_\_\_\_ Graphic Punch: \_\_\_\_\_ Card Electro Number: \_\_\_\_\_

Page 1 of 2 Program Identification: 75 76 77 78 79 80

GX21 9094 U/M 050\*  
Printed in U.S.A.

Line	Form Type	Filename	Sequence Number (FN) Option (O)	Record Identifying Indicator	Record Identification Codes									Field Location		Field Name	Control Level (L1-L9)	Matching Fields or Chaining Fields	Field Record Relation	Field Indicators				
					1	2	3	Position	From	To	Plus	Minus	Zero or Blank											
01	I	INPUT	AA	01											1	5	CLASS	L1						
02	I														6	12	ITEMNO							
03	I														13	32	DESC							
04	I														33	38	ONHAND							
05	I														39	44	DATE							

**IBM** International Business Machine Corporation

Program: \_\_\_\_\_  
 Programmer: \_\_\_\_\_ Date: \_\_\_\_\_

### RPG OUTPUT SPECIFICATIONS

Punching Instruction: \_\_\_\_\_ Graphic Punch: \_\_\_\_\_ Card Electro Number: \_\_\_\_\_

Page 1 of 2 Program Identification: 75 76 77 78 79 80

GX21 9090 U/M 050\*  
Printed in U.S.A.

Line	Form Type	Filename	Type (H/D/E)	Stacker # / Field (E)	Space Before After	Skip Before After	Output Indicators			Field Name	End Position in Output Record	Constant or Edit Word
							And	And	And			
01	O	OUTPUT	H	20	L				LL			
02	O		OR						QVINLL			
03	O									25	'CLASS'	
04	O									40	'ITEM NO'	
05	O									64	'DESCRIPTION'	
06	O									82	'ONHAND'	
07	O		D	1								
08	O								LL	25	CLASS	
09	O									40	ITEMNO	
10	O									69	DESC	
11	O									81	ONHANDZ	
12	O		T	26	L							
13	O									53	'IN STOCK AS OF'	
14	O									62	DATE Y	

Figure 2-4. Defining and Using a Control Field

### Split Control Fields

Two separate parts of a field or two separate fields can be used as *one* control field known as a split control field. This is done by assigning the same control level indicator to both parts of the field. The compiler will consider the data in the split control fields as *one* continuous field.

Suppose you have a 3-character customer number field in the record and now need a 6-character field. The problem is how to put a larger customer number (such as 100010, 100020) in a 3-character field. You cannot change records easily because there is no room for expansion on either side of the customer number field (Figure 2-5), and to expand the field, the entire record format would have to be changed. All programs using these records would also have to be changed to accommodate the changed record format. This would be considerable work and inconvenience. RPG II provides the split control field feature to meet changing data processing needs with minimum effort.

The solution to the problem is to add a 3-character portion to the customer number field using three columns which are not adjacent to the original customer number field (Figure 2-6). The original three numerals of the customer number remain in the original field. The three additional numbers are put in the new customer number field.

At the end of each month, a report is produced consisting of:

1. Customer number.
2. A description of each purchase.
3. The cost of each purchase.
4. The total cost of all purchases.

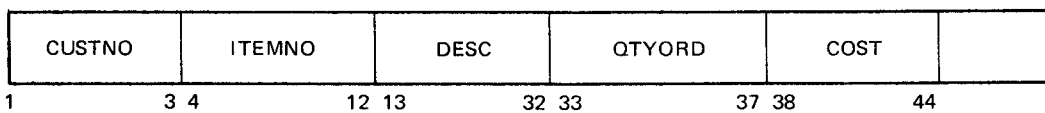

Figure 2-5. Three Digit Customer Field

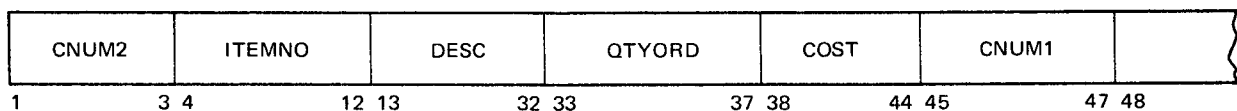

Figure 2-6. One Customer Number Split into Two Parts



The report is group-indicated as shown in Figure 2-7.

The customer number determines when totals would be printed and thus must be used as a control field. However, on each record the customer number is split into two parts (two fields). Both must be used in order to get the correct customer number (Figure 2-8).

### Coding Split Control Fields

Split control fields must be described in specification lines which follow one another (Figure 2-8, insert A).

CNUM1, the field in columns 45-47 of the record, must be specified on the Input sheet before CNUM2, the field in positions 1-3. This is required because the three digits in CNUM1 are the first three digits of the customer number.

Parts of a split control field may be either alphameric or numeric. In this example, they were both defined as numeric (indicated by the entry in column 52). If one of them, however, had been defined as numeric and one as alphameric, they both are considered numeric by the compiler.

## CHECKING THE SEQUENCE OF RECORD TYPES

Many data processing jobs require the use of several kinds of information. Sometimes, this information must be in a special order to produce the correct results.

### Order of Record Types Within a Group

For example, to do end-of-the-month billing, you need several kinds of information. For each account you must know:

1. The balance forward at the beginning of the month.
2. Payments made during the month.
3. Purchases made during the month.

To get the amount due, you subtract payments made from the balance forward and then add new purchases to that amount.

Information concerning balance forward, payments, and purchases is usually on more than one record. Payments are usually recorded as they are received. Purchases are recorded as they are made. The balance forward is also kept on a separate record.

CUSTOMER	PURCHASES	COST	
001249	# 14 NAILS	2.49	
	# 9 NAILS	3.78	
			\$ 6.27 *
001254	HAMMER	1.29	
	ELECTRIC SAW	42.85	
			\$44.14 *
001497	2' X 4's	17.93	
			\$17.93 *
001972	PLYWOOD	7.43	
			\$ 7.43 *
002024	TILE	87.93	
			\$87.93 *

Figure 2-7. Report Group Printed by Customer Number



Thus, to do the billing, three different types of records are necessary for each account. Furthermore, these records must be read in a special order. The balance forward record must come first. The payment and purchase records can be in any order; it makes no difference whether you subtract all payments first, or add all receipts first, or add receipts and subtract payments in any order. However, you must decide on the order of these records for your program and keep them in that order, since the computer will always expect them in a certain order.

Management of a retail store requires all receipts to be listed and subtracted before purchases are listed and added. Thus, the order in which the records must be read is:

1. Balance Forward.
2. Payments.
3. Purchases.

Remember that these three types of records are necessary for *one* account. When they are organized, they are organized according to account. Each record has a name on it. All records with the same name must be grouped together in the file and must be in the order indicated (see Figure 2-9, part A).

What if one of the records accidentally got out of order? Some customer would end up with the wrong amount.

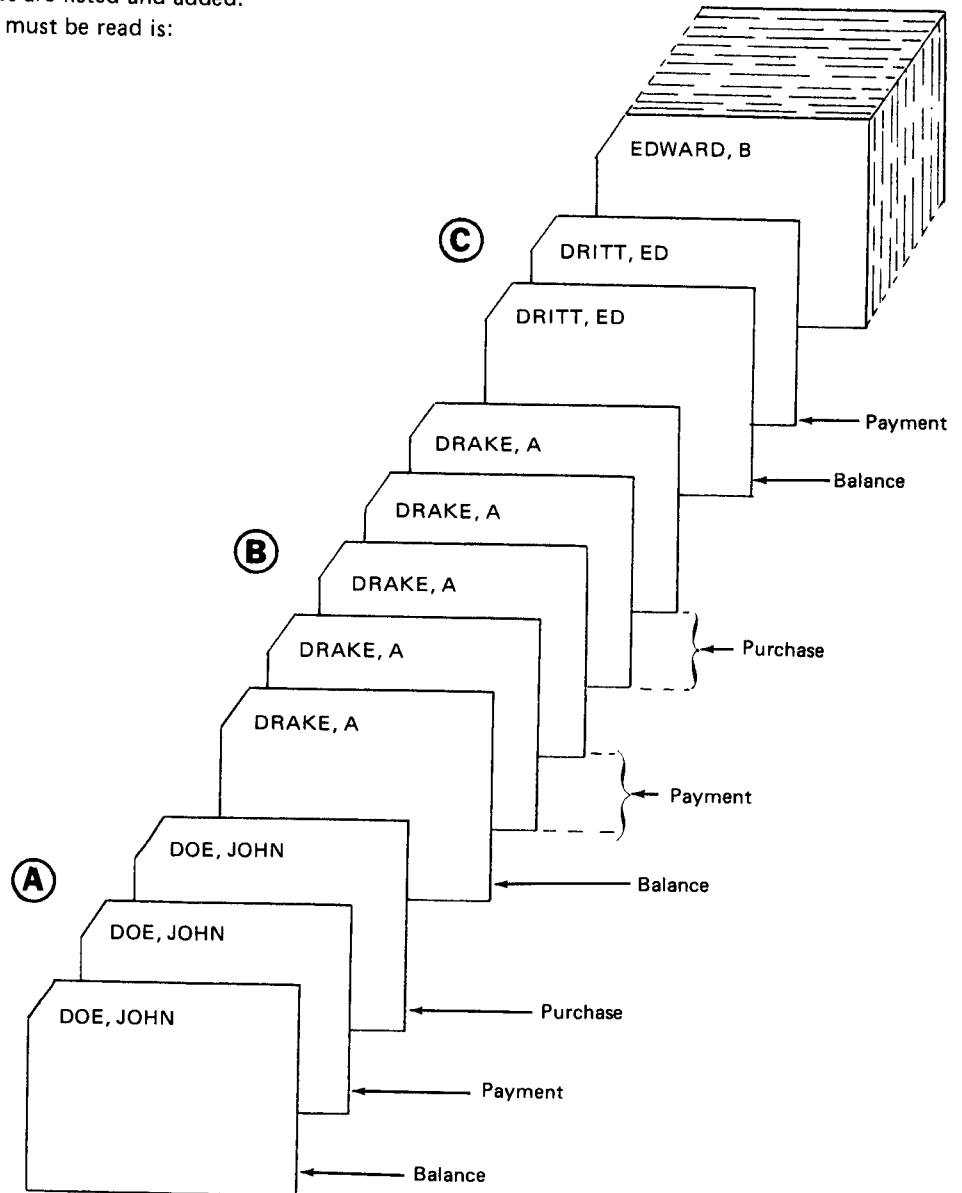

Figure 2-9. Order of Record Types Within a Group

To prevent this, you direct your program to check for record sequence by entries in columns 15-16 on the Input sheet. These columns are titled *Sequence* and are used for indicating the sequence of record types for each account.

These sequence columns are used for *every* program you write. If you are not checking for a special order, these columns must contain alphabetic entries. If you are checking for a special order, these columns must contain numeric entries (01-99).

Since it is first, the Balance record must be given the sequence entry 01 (see Figure 2-10). What sequence entries would the Payment and Purchase records have? Logically, they would be 02 and 03 respectively (Figure 2-10). However, you could have used 09 and 20. You may use any numbers from 01-99 just as long as the numbers used are in ascending order. However, 01 must always be used.

RPG INPUT SPECIFICATIONS																																																															GX21-9094 U/M 050*								
IBM International Business Machine Corporation																																																															Printed in U.S.A.								
Program			Punching Instruction			Graphic			Card Electro Number			Page 1 2 of		Program Identification 75 76 77 78 79 80																																																									
Programmer		Date		Instruction		Punch																																																																	
Line	Form Type	Filename	Sequence		Record Identification Codes									Field Location			Field Indicators																																																						
			O	R	1			2			3			From	To	Decimal Positions	Field Name	Control Level (L1-L9)	Matching Fields or Omitting Fields	Field Record Relation	Plus	Minus	Zero or Blank																																																
3	4	5	6	7	8	9	10	11	12	13	14	15	16	17	18	19	20	21	22	23	24	25	26	27	28	29	30	31	32	33	34	35	36	37	38	39	40	41	42	43	44	45	46	47	48	49	50	51	52	53	54	55	56	57	58	59	60	61	62	63	64	65	66	67	68	69	70	71	72	73	74
01	I	BILLING	0	1	Balance Record																																																																		
02	I		0	2	Payment Record																																																																		
03	I		0	3	Purchase Record																																																																		
04	I																																																																						
05	I																																																																						
06	I																																																																						

Figure 2-10. Record Sequence

Since there are three different types of records, each should be identified by a code so that the computer knows which record type was read. Record identifying indicators should be specified for each record type. All fields in each record type must also be described. Figure 2-11 shows how the records kept by the retail store were described.

How does the entry specifying sequence help you check for record sequence? Suppose a payment record was read after a purchase record. This would be incorrect order. The program knows that a 02 record type doesn't come after a 03 type and will automatically halt because of the mistake.

### More Than One Record Type Per Group

What would happen if two payment records (02 record type) were read in a row? The program would halt because it expects a 03 record type to follow a 02 type. It does not expect two 02 types in a row. But what if a customer actually made two payments during the month? Or what if he bought more than one item during the month? You wouldn't want the program to halt whenever it read more than one payment of purchase record per customer.

You must make another entry to indicate whether the program can expect to read one or more records of the same

type in one group. This entry is made in column 17 (Number) of the Input sheet. A 1 indicates only one record per type; an N indicates one or more records per type. In this example, only one balance record is needed. However, there may be more than one payment record or purchase record. Figure 2-12 shows these entries.

### Optional Record Types in the Group

It is also possible in this example to have no purchase record. A customer might not have purchased anything during the month. If so, a balance record would be read after a payment record for the previous customer (see Figure 2-9, part C). According to the specifications shown, this is incorrect order. The program would halt.

To prevent halting in this situation, you must make another entry, this time in column 18. Place the letter O in column 18 to indicate that the record type is optional (it may or may not be present). If you leave column 18 blank, the computer assumes that the record type *must always* be present.

Of the three record types, which must always be there? The balance forward record should be present. Leave column 18 blank for it. The other two record types are optional. Enter the letter O for each (see Figure 2-13).

IBM		International Business Machine Corporation		RPG INPUT SPECIFICATIONS												GX21-9094 U/M 050*		Printed in U.S.A.	
Program				Punching Instruction		Graphic Punch		Card Electro Number				Page 1 2 of		Program Identification 75 76 77 78 79 80					
Line	Form Type	Filename	Sequence		Record Identification Codes			Field Location		Field Name	Control Level (L,L,C)	Matching Fields or Chaining Fields	Field Record Relation	Field Indicators					
			Number (1-N)	Option (O)	Record Identifying Indicator	Position	Not (N) C/Z/D Character	Position	Not (N) C/Z/D Character					Position	Not (N) C/Z/D Character	From	To	Plus	Minus
0 1	I	BILLING	01		11	96	C1												
0 2	I																		
0 3	I																		
0 4	I																		
0 5	I																		
0 6	I		02		12	96	C2												
0 7	I																		
0 8	I																		
0 9	I		03		13	96	C3												
1 0	I																		
1 1	I																		
1 2	I																		
1 3	I																		

Figure 2-11. Description of Sequenced Record Types

**IBM** International Business Machine Corporation

**RPG INPUT SPECIFICATIONS** GX21-9094 U/M 050\*  
Printed in U.S.A.

Program		Punching Instruction		Graphic		Card Electro Number	
Programmer		Date		Punch			

Page 1 of 2 Program Identification 75 76 77 78 79 80

Line	Form Type	Filename	Sequence	Record Identification Codes						Field Location		Field Name	Control Level (L1-L9)	Matching Fields or Chaining Fields	Field Record Relation	Field Indicators		
				1	2		3	From	To	Plus	Minus					Zero or Blank		
				Position	Not (N) C/Z/D Character	Position	Not (N) C/Z/D Character	Position	Not (N) C/Z/D Character	Stacker Select P/B/L/R	Decimal Positions							
0 1	I	BILLING	Ø	1	1													
0 2	I																	
0 3	I																	
0 4	I																	
0 5	I		Ø2															
0 6	I																	
0 7	I																	
0 8	I																	
0 9	I		Ø3															
1 0	I																	
1 1	I																	

**Annotations:**  
 → 1 indicates only one Balance Record per group.  
 → N indicates one or more Payment Record per group.  
 → N indicates one or more Purchase Records per group.

Figure 2-12. Number of Each Record Type Per Group

**IBM** International Business Machine Corporation

**RPG INPUT SPECIFICATIONS** GX21-9094 U/M 050\*  
Printed in U.S.A.

Program		Punching Instruction		Graphic		Card Electro Number	
Programmer		Date		Punch			

Page 1 of 2 Program Identification 75 76 77 78 79 80

Line	Form Type	Filename	Sequence	Record Identification Codes						Field Location		Field Name	Control Level (L1-L9)	Matching Fields or Chaining Fields	Field Record Relation	Field Indicators		
				1	2		3	From	To	Plus	Minus					Zero or Blank		
				Position	Not (N) C/Z/D Character	Position	Not (N) C/Z/D Character	Position	Not (N) C/Z/D Character	Stacker Select P/B/L/R	Decimal Positions							
0 1	I	BILLING	Ø															
0 2	I																	
0 3	I																	
0 4	I																	
0 5	I		Ø2															
0 6	I																	
0 7	I																	
0 8	I																	
0 9	I		Ø3															
1 0	I																	
1 1	I																	

**Annotations:**  
 → A blank indicates that the Balance Record must be present.  
 → O indicates that the Payment Record is optional.  
 → O indicates that the Purchase Record is optional.

Figure 2-13. Optional Record Types in a Group

### Checking the Order of Record Types in a Group

In summary, three entries must be made to ensure proper checking of the sequence of records in a group.

1. Columns 15-16 must contain a numeral from 01 through 99 that indicates the order in which records must be read.
2. Column 17 must contain an entry that indicates whether or not more than one record of a type can be expected. A 1 indicates that only one record of a type will be accepted. An N indicates that more than one record of a type will be accepted.
3. Column 18 must contain an entry which indicates whether or not the record type is optional. The letter O indicates that the record type is optional. A blank indicates that the record type must be present.

### Incorrect Records Within a Group

The entries for checking the sequence of record types within a group will determine that the records in groups A and B shown in Figure 2-14 are in order. Suppose, however, that the payment records for John Hill and A. James were mixed up (Figure 2-15). The program using the sequence specifications just described would not find this error. The record types are still in proper order, but the records themselves are in the wrong groups. To ensure that records are in the right group other specifications have to be made.

For the end-of-month billing example, the NAME field is used as a control field. A change in the NAME field indicates the end of one group and the start of another. Since the balance record is always the first one in a new group, the balance record type should be the only one that causes a control break. If the records are mixed up, as shown in Figure 2-15, a control break will occur before all records of one group have been read. For example, when the Arnold James' payment record is read after a John Hill balance record, a control break occurs because information in the NAME field changes. There should be no control break at this time. If there is a control break *here*, the results of the report will be inaccurate.

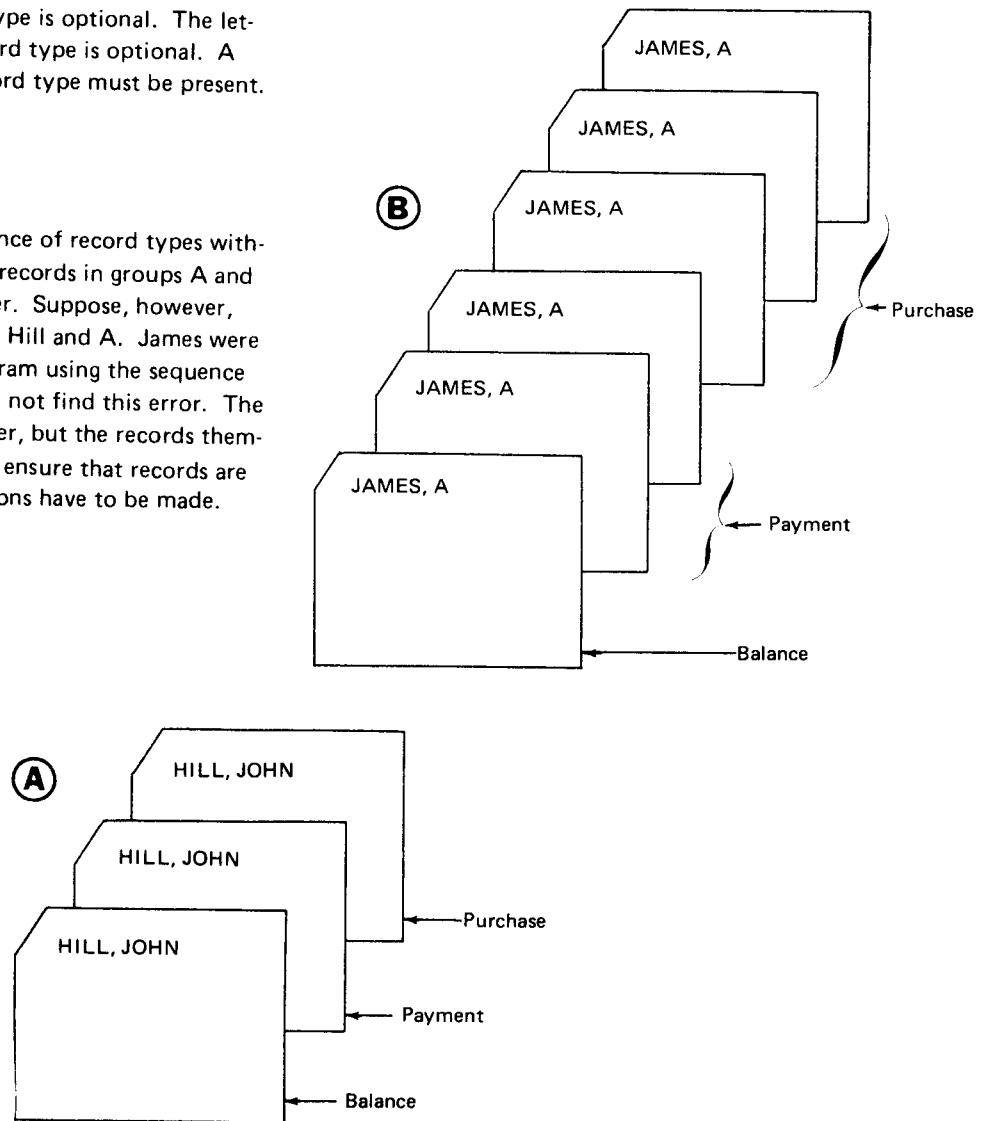

Figure 2-14. Correct Data Records in a Group





Look at the indicators which condition the SETON operation, L1 and N01. A control break (L1 turns on) caused by record type 01 (balance record) is correct. But a control break (L1) caused when any other record type (02 or 03) is read indicates that a record is in the wrong group. This is an error condition. Thus when L1 is on (a control break has occurred) with any record identifying indicator other than 01 (N01), the halt indicator H1 is set on to stop processing.

Halting on an error is one way of handling error conditions. This method allows you to stop, correct the record in error, and start processing over again. This often wastes time since you must restart the computer each time an error is found. Programming to bypass the error is more often done. This will be discussed at a later time.

### Sequenced and Unsequenced Record Types in a Group

So far we have talked about having records in a group which must be in a special sequence. However, you may also have records in the group which need not be in any sequence. In this case, all records which do not need to be in sequence are specified on the Input sheet before those that do. Remember that unsequenced records must have alphabetic entries in columns 15-16, and blanks in columns 17-18.

### Unexpected or Unused Records Within a Group

If the computer reads any record types which are not specified, it will halt. Often you may have several record types within a file, but the job being done requires the use of only a few of the record types. Do you still have to specify each type? No, you don't. But remember each time an undescribed type is found, the program halts. This could result in wasted time. Therefore, to prevent halting and to eliminate a description of each record type, you specify a *catch-all* indicator in addition to specifying all record types needed (see Figure 2-17).

Line		Form Type	Filename	Sequence	Number (N)	Custom (C)	Record Identifying Indicator	Record Identification Codes																																
3	4	5	6	7	8	9	10	11	12	13	14	15	16	17	18	19	20	21	22	23	24	25	26	27	28	29	30	31	32	33	34	35	36	37	38	39	40	41		
				O	R			1			2			3																										
				A	N	D			Position	Not (N)	C/Z/D	Character	Position	Not (N)	C/Z/D	Character	Position	Not (N)	C/Z/D	Character																				
01	I		RECORDS				NS	99	96	N	CA	96	N	CB	96	N	CC																							
02	I																																							
03	I																																							
04	I																																							
05	I																																							
06	I																																							
07	I																																							
08	I																																							
09	I																																							
10	I																																							
11	I																																							
12	I																																							
13	I																																							
14	I																																							

These record types are not described for they are not needed. The catch-all sequence entry causes all to be considered as type 99.

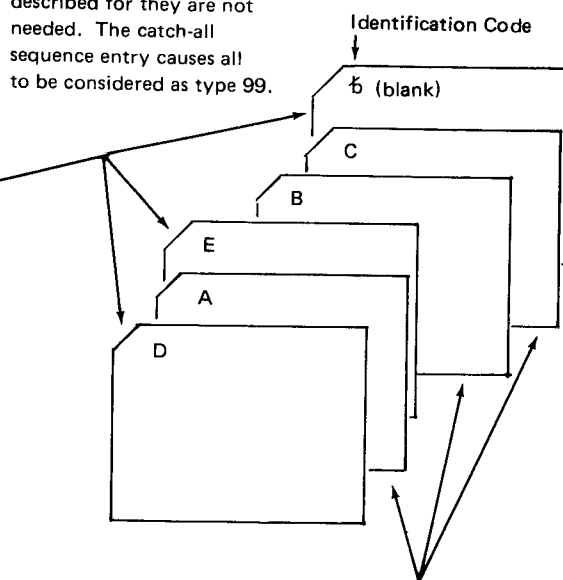

These record types are individually described because they are used for the job.

Figure 2-17. Catch-All Sequence Entry

According to the specifications in Figure 2-17, any record read which does *not* have one of the identification codes specified, is considered to be record type 99. If no operations are conditioned by record identifying indicator 99, none will be done for all records which are considered type 99.

You may also use a catch-all indicator specification to prevent halting when unexpected records (record in wrong file, blank record, etc.) are read. Unwanted card records are normally stacked selected into a special stacker so that they can be removed from the deck at the end of the job.

Figure 2-18 shows specifications that describe three unsequenced record types used in the program and a catch-all indicator which will be assigned to unwanted record types found in the file. When records are not in a special order, (alphabetic entries in columns 15-16), the catch-all indicator is described last with no Record Identification Codes. The catch-all indicator turns on if a card is read which can not be identified by any of the preceding Record Identification Codes.

### FIELD RECORD RELATION INDICATORS

You may have some programs which process several different record types. Two or more record types might contain identical fields. To eliminate coding these identical fields for every record type you may use the OR relationship which indicates that certain fields are found on all record types. Not all fields are identical in different record types, however. You must have some way of specifying those fields found on only specific record types in the OR relationship. Field record relation indicators indicate those fields found on only specific record types.

Field record relation indicators will relate:

- A field to a specific record type in the OR relationship.
- Control fields and split control fields to a specific record type in an OR relationship.
- Match fields for more than one record type (see *Match Fields and Multifile Processing*).

### OR Relationship

You can eliminate duplicate coding by using an OR relationship to describe identical record types. This method also reduces the size of the program.

When using the OR relationship, you need to write the names of identical fields from more than one type of record only once on the Input Sheet. OR relationship specifications indicate that the fields named may be found on all of the record types. The following input specifications are necessary to set up the OR relationship:

1. Record identifying indicators (01-99) for each record type.
2. The letters OR in columns 14-15 for all record types other than the first.
3. Entries describing the record identification code of each record type (columns 21-41).

RPG INPUT SHEET																																							
Programmer														Date										Punching Instruction					Graphic Punch										
I														Record Identification Codes																									
Line	Form Type	Filename	Sequence		Number (I/N)	Out (C)	Record Identifying Indicator	1			2			3			4			5			6			7			8			9			0				
			O	R				Position	Not (N)	Character	Position	Not (N)	Character	Position	Not (N)	Character	Position	Not (N)	Character	Position	Not (N)	Character	Position	Not (N)	Character	Position	Not (N)	Character	Position	Not (N)	Character	Position	Not (N)	Character	Position				
01	I	CARDS	AA		01			96		C1																													
02	I																																						
03	I																																						
04	I		BB		02			96		C2																													
05	I																																						
06	I																																						
07	I																																						
08	I		CC		03			96		C3																													
09	I																																						
10	I																																						
11	I		DD		04																																		
12	I																																						

Figure 2-18. Unsequenced Record Types with Catch-All Sequence Entry



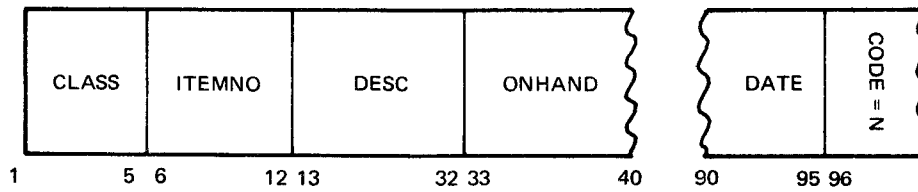

New Item Record

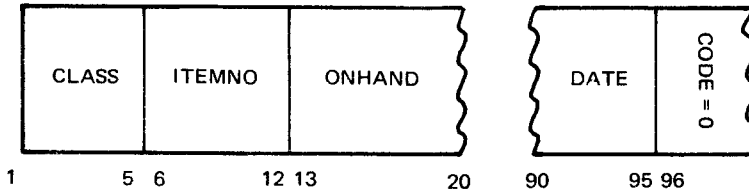

Regular Item Record

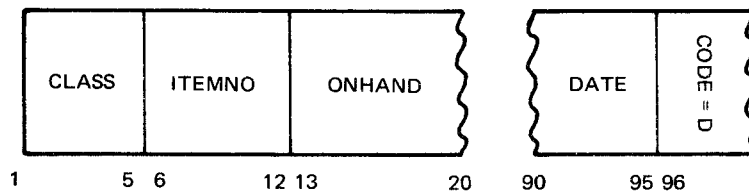

Discontinued Item Record

Figure 2-20. Record Types with Some Identical Fields

**RPG INPUT SPECIFICATIONS**

GX21 9094 U/M 050  
Printed in U.S.A.

---

Program \_\_\_\_\_ Punching Instruction \_\_\_\_\_ Graphic \_\_\_\_\_ Card Electro Number \_\_\_\_\_  
 Programmer \_\_\_\_\_ Date \_\_\_\_\_ Punch \_\_\_\_\_ Page 1 2 of \_\_\_\_\_ Program Identification 75 76 77 78 79 80

Line	Form Type	Filename	Sequence Number (1-N) A N D	Record Identifying Indicator or	Record Identification Codes									Field Location		Field Name	Control Level (L1-L9) Matching Fields or Changing Fields	Field Record Relation	Field Indicators			
					1	2	3	From	To	Plus	Minus	Zero or Blank										
					Position	Not (N) C/Z/D Character	Position	Not (N) C/Z/D Character	Position	Not (N) C/Z/D Character	Position	Not (N) C/Z/D Character	Star/Select P/B/L/R	Decimal Positions								
01	I																					
02	I	INVENTORYAA	01		25	96	27	CN														
03	I		02		25	96	27	CD														
04	I		03		25	96	27	CO														
05	I																					
06	I																					
07	I				1		5	CLASS														
08	I				6		12	ITEMNO														
09	I				90		95	DATE														
10	I																					
11	I				13		32	DESC													01	
12	I				33		40	ONHAND													01	
13	I				13		20	ONHAND													02	
13	I				13		20	ONHAND													03	

● Figure 2-21. Field Record Relation



**CONDITIONING USE OF INPUT FILES (EXTERNAL INDICATORS)**

Thus far, in this chapter, you have read about jobs that require the complete processing of all input files specified. The following topics will illustrate how you can use RPG II to do jobs for which:

1. It is not necessary to process one or more of the files.
2. It is not necessary to process an *entire* file.

**Using One Program to do More Than One Job**

Have you ever thought how useful it would be if, when doing similar jobs, you could use one program to perform more than one function?

Consider, for example, the following jobs. Two types of reports are required each week. One is a sales analysis report showing what items sold during the week. The second is an inventory report showing balance on hand for each item in stock. Notice the similarity in the format of the reports (Figure 2-23).

SALES ANALYSIS		
ITEM NUMBER	AMOUNT SOLD	DATE
46732	7	09/15/70
	8	09/16/70
	2	09/17/70
	1	09/19/70
46739	12	09/15/70
	20	09/16/70
	25	09/17/70
	8	09/18/70
	3	09/19/70

BALANCE FORWARD			
ITEM NUMBER	AMOUNT SOLD	DATE	BALANCE
46732	7	09/15/70	
	8	09/16/70	
	2	09/17/70	
	1	09/19/70	
			150*
46733			
			32*
46739	12	09/15/70	
	20	09/16/70	

Figure 2-23. Two Similar Reports from Two Different Jobs

Two files are available: the MASTER file which contains balance forward records for all items in the store; and a transaction file (TRANS) which contains all the weekly sales for each item (Figure 2-24). Both files are in ascending order by item number.

The sales analysis report merely requires a listing of records found in the transaction file.

The inventory report requires that records from two files be matched. (If you are not familiar with multifile processing using two input files, see the chapter *Match Fields*

and *Multifile Processing*.) When records from both files match, the number sold is subtracted from the balance on hand. The new balance is then printed on the report following the list of transactions.

One report requires two files; the other only one. How could you write one program to produce reports which have such different file requirements? If you had some way of telling the program when to expect the use of one file and when to expect two files, it could be done.

This you can do with external indicators.

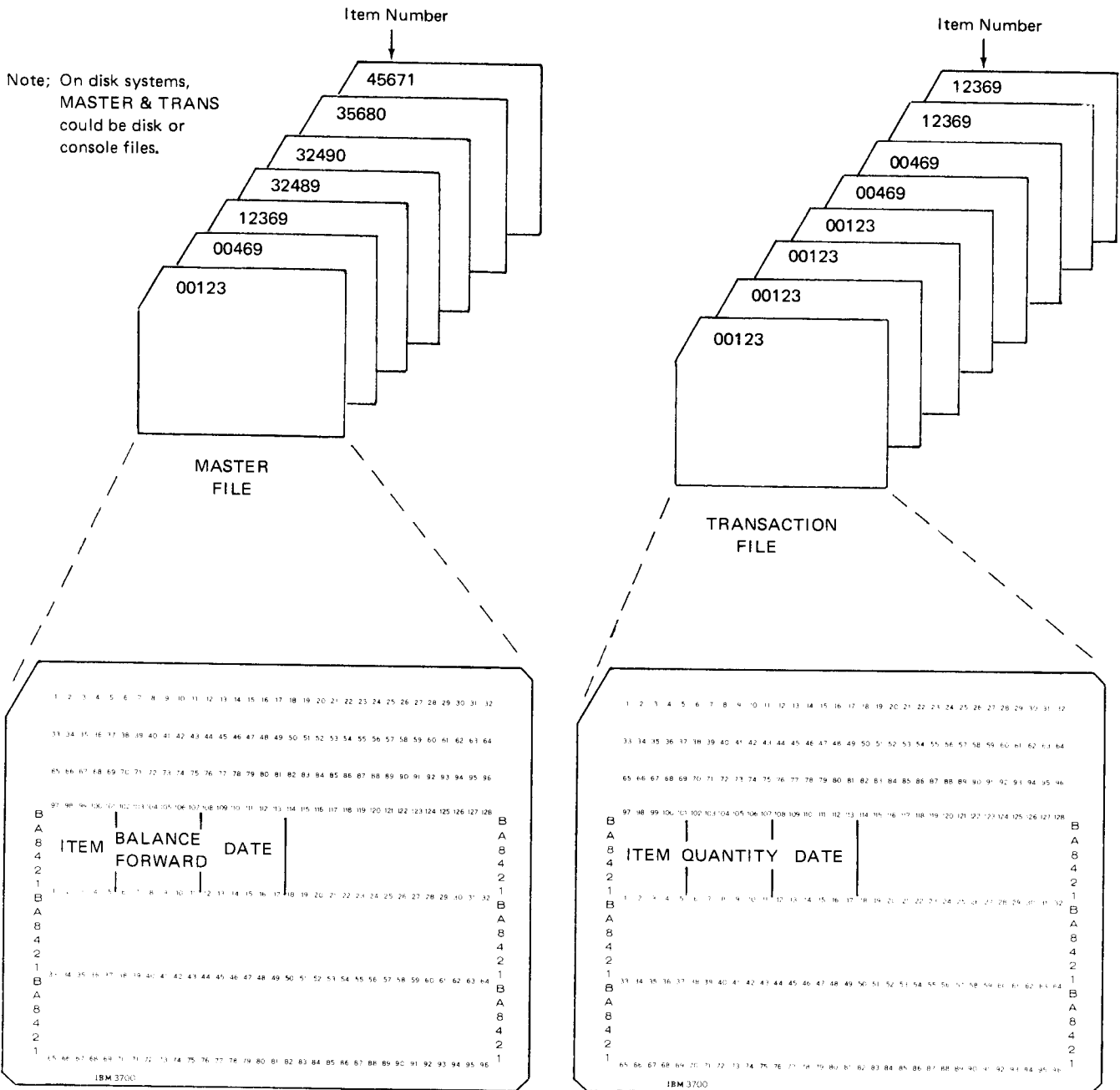

Figure 2-24. Format of Records Used to Produce Sales Analysis and Balance Forward Reports

### Setting External Indicators

You are already familiar with several types of indicators used in the RPG II language. These indicators are used to:

1. Signal the occurrence of a specific condition, such as matching records, control break, or last record.
2. Control when certain operations should be performed; such as only when a control break occurs, or when a specific record type is read.

Most indicators are set by the program on the basis of the conditions which occur during the execution of the program. External indicators, however, are set by you prior to the execution of the program. You do this in one of the following ways, depending on which System/3 model you have:

**Model 10 Card System:** In order to set external indicators in the Card System, enter an Indicator Control Card in the System Initialization Program. The control card must have the following format:

Columns	Entry
1-2	// (two slashes)
3	blank
4-6	IND
7	blank
8-15	One-position entries indicating the setting of U1 through U8. Indicator U1 is set in column 8, U2 in column 9, and so on, as follows:
	1 Indicator is turned on
	0 Indicator is turned off
	⌀ (blank) Indicator remains as it was set in the last job
16-96	blank

Figure 2-25 shows an Indicator Control Card which causes external indicators U1 and U8 to be set on, indicators U2 through U6 to be set off, and indicator U7 to remain as it was in the previous program.

Once an indicator is set, it is not changed during the entire program. The only way the setting may be changed for the next program is by another Indicator Control Card entered in the System Initialization Program.

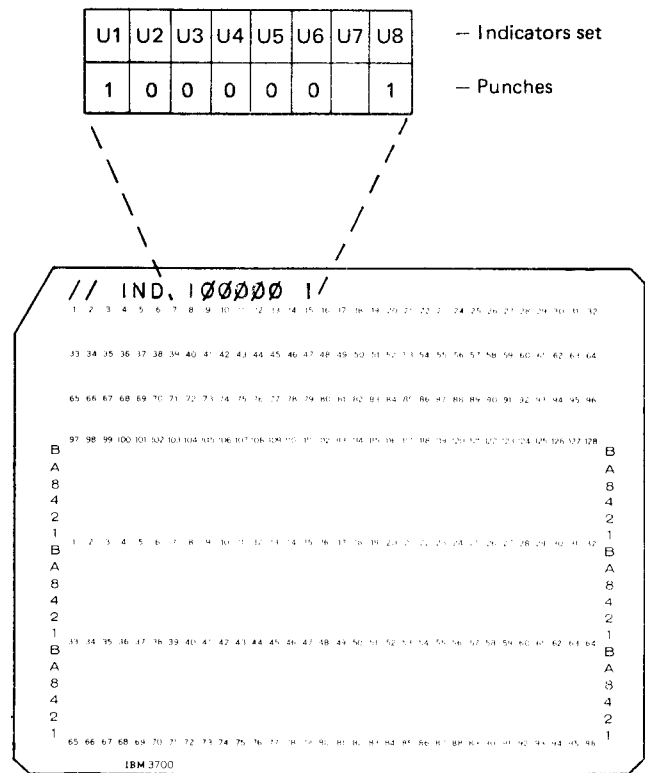

Figure 2-25. Indicator Control Card (Model 10 Card System)

**Model 10 Disk System and Model 15:** Although most indicators are set by the program, you set external indicators prior to the execution of the program. This is done by including a SWITCH statement in your Operational Control Language. The format of the SWITCH statement is:

```
// SWITCH indicator settings
```

- The indicator settings are:
- 1 = indicator is turned on.
  - 0 = indicator is turned off.
  - X = indicator is unaffected.



Figure 2-26 shows a SWITCH statement which sets external indicators U1 and U8 on and indicators U2 through U6 off. Indicator U7 is unaffected.

Once an indicator is set, it is not changed until you provide another SWITCH statement or perform IPL. You cannot use the SETON or SETOF operation codes with external indicators.

On the Model 15, when operating in job mode, SWITCH settings are reset to 0 at end of job.

**Model 6:** The operator sets external indicators prior to execution of the program by responding to the SWITCH keyword displayed by the system. An eight-position response is possible, corresponding to the eight external indicators. Possible entries for each position are:

- 1 = indicator is turned on.
- 0 = indicator is turned off.
- X = indicator remains unchanged.

For example, if the operator keys XXXX10XX in response to the SWITCH keyword:

- Indicator U5 is turned on.
- Indicator U6 is turned off.
- Indicators U1, U2, U3, U4, U7, and U8 remain unchanged.

While displaying the SWITCH keyword, the system displays the previous external indicator setting. If all indicators are to remain unchanged, the operator responds to SWITCH by pressing PROG START.

Indicators set by the SWITCH keyword retain their settings until another SWITCH statement changes them or the next IPL occurs.

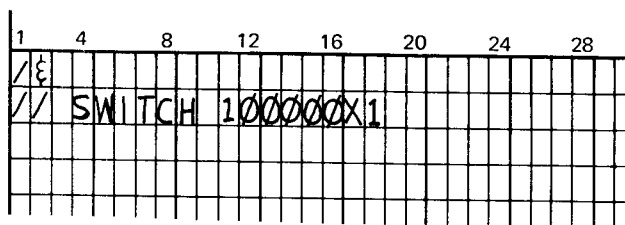

Figure 2-26. SWITCH Control Statement

#### Using an External Indicator to Condition a File

You can assign an external indicator to a file. When the indicator is on, the file is used; when it is off, the file is not

used. This then is how you can tell a program when to expect one file and when to expect two. Consider again the two jobs discussed previously: sales analysis and inventory.

The TRANS file is needed for both jobs, the MASTER file is only needed for the inventory job. Thus, the MASTER file is assigned the U1 indicator. You set the indicator on for the inventory job (MASTER is used here) and off for the sales analysis job (MASTER is not used here).

The U1 indicator is assigned to a file on the File Description sheet in columns 71-72. Any of the eight external indicators (U1-U8) could be used. U1 was arbitrarily chosen for this example (Figure 2-27).

Naturally, the calculations performed and the type of report written out will depend upon which job is being done. Different calculation and output-format specifications are needed for each. In order to determine which specifications to use for a particular run of the program, calculation and output-format specifications must also be conditioned by the external indicator. This topic will be further discussed under *Controlling Operations in an RPG II Program*.

When writing a program which can do two jobs, be certain that the two jobs are very similar. Where the jobs require many different calculations and output operations, it would be easier to write two different programs than to use external indicators.

#### Ending the Program Before Processing All Files Completely

When should end-of-job operations take place? The program would normally end after all records have been processed. When you are reading one file, you usually want to process all records in that file. Normally, you wouldn't want to process a few records and then end the program unless, of course, you found an error condition. The computer also operates under the assumption that all records in the file should be processed before the program ends. The LR (last record) indicator which conditions end-of-job operations is not turned on until the last record has been processed.

Suppose, however, that you are using two files in your program. The computer assumes that all records in both files must be processed before the program ends. If you want the program to end before all records in both files are processed (for example, when the secondary file runs out of records), you can specify this. This is done by placing an E in column 17 of the File Description sheet for the file which will terminate the program.

**File Description Specification**

F		File Type		Mode of Processing		Device	Symbolic Device	Labels S/N/E/M	Name of Label Exit	Extent Exit for DAM		File Addition/Unordered			
Line	Form Type	File Designation		Length of Key Field or of Record Address Field	Record Address Type					Type of File Organization or Additional Area	Overflow Indicator	Key Field Starting Location	Extension Code E/L	Core Index	Number of Tracks for Cylinder Overflow
		End of File	Sequence						File Format						Block Length
0 2	F	MASTER	IP AF				96			MFCU2			UL		
0 3	F	TRANS	CS AF				96			MFCUL					
0 4	F	PRINT	O F				100			PRINTER					
0 5	F														
0 6	F														
0 7	F														
0 8	F														
0 9	F														
1 0	F														
	F														
	F														

**Figure 2-27. Assignment of an External Indicator**

Figure 2-28 shows the File Description sheet used in a billing program that is to end when the last record of the secondary file has been processed. This is indicated by an E in column 17.

**File Description Specification**

F		File Type		Mode of Processing		Device	Symbolic Device	Labels S/N/E/M	Name of Label Exit	Extent Exit for DAM		File Addition/Unordered			
Line	Form Type	File Designation		Length of Key Field or of Record Address Field	Record Address Type					Type of File Organization or Additional Area	Overflow Indicator	Key Field Starting Location	Extension Code E/L	Core Index	Number of Tracks for Cylinder Overflow
		End of File	Sequence						File Format						Block Length
0 2	F	MASTER	IP F				96			MFCUL					
0 3	F	BALDUE	ISE F				96			MFCU2					
0 4	F														
0 5	F														
0 6	F														
0 7	F														
0 8	F														
0 9	F														
1 0	F														
	F														
	F														

**Figure 2-28. End-of-Job Specification**





2. A large warehouse requires a weekly report showing the quantity of each item in stock. Three types of records are found in the file for every item in stock:
- In Stock*, which records the quantity in stock at the beginning of the week. This record must be present, and there can be only one per item. It is identified by a Q in column 96.
  - Receipt*, which records the quantity brought into the warehouse. This record is optional. There may be several per item. It is identified by an I in column 96.
  - Issue*, which records the quantity shipped out of the warehouse. This record is optional. There may be several per item. It is identified by an O in column 96.

ITEMNO	DATE	INSTOK
1 2 3 4 5 6 7 8 9 10 11 12 13 14 15 16 17 18 19 20 21 22 23 24 25 26 27 28 29 30 31		

INSTOCK Record

ITEMNO	DATE	SHIPIN
1 2 3 4 5 6 7 8 9 10 11 12 13 14 15 16 17 18 19 20 21 22 23 24 25 26 27 28 29 30 31		

RECEIPT Record

ITEMNO	DATE	OUT
1 2 3 4 5 6 7 8 9 10 11 12 13 14 15 16 17 18 19 20 21 22 23 24 25 26 27 28 29 30 31		

ISSUE Record

The records are grouped according to item number. All records of one item number must be in the order listed previously. Using the information given, write the Input specifications which are necessary to:

- Check the sequence of the records in each group.
- Prevent halting if unwanted or unused record types are read.















**CHAPTER 3 DESCRIBES:**

RPG II overflow and fetch overflow to control page formatting.

RPG II fetch overflow object program cycle.

Aligning printer forms.

Editing with edit words.

Using the special RPG II word, \*PLACE, to print duplicate information.

Dual printer files.

**BEFORE READING THIS CHAPTER YOU SHOULD BE ABLE TO DESCRIBE:**

The RPG II object program cycle for overflow.

Function of RPG II indicators.

Using edit codes to punctuate numeric data.

**AFTER READING THIS CHAPTER YOU SHOULD BE ABLE TO DESCRIBE:**

RPG II overflow and fetch overflow.

Effects of fetch overflow on the RPG II object program cycle.

Aligning printer forms.

Using edit words.

\*PLACE

Coding for the Dual Feed Carriage Feature on the IBM 5203 Printer and coding for Dual Feed Tractors on the IBM 2222 Printer.

*Note:* You can use the review questions contained in *Review 3* at the end of this chapter to test your comprehension of each topic in the chapter. Questions are grouped according to the topic to which they apply. Answers follow the review questions.

## INTRODUCTION

The most important part of any RPG II program is the result—the output. This chapter describes the RPG II coding necessary to format and punctuate printed output to make it easier to read and understand. Methods are also described for duplicating information on the output record and using dual printer files to print two reports in the same program.

Using the printer, you can create a report consisting of individual lines (records) recorded consecutively on stock paper. You may also use it to record information on your own preprinted forms, such as on bills, invoices, and checks. Regardless of the paper or form you are printing on, you are always interested in obtaining a report that is neat and readable. This means that the format of the report and data on the report must be considered when planning the program.

RPG II coding for the different printers available on System/3 is nearly identical. Differences in coding are noted. The available printers are:

- IBM 5203 Printer (Model 10)
- IBM 1403 Printer (Model 10 Disk System and Model 15)
- IBM 5213 Printer (Model 6)
- IBM 2222 Printer (Model 6)

## USING OVERFLOW AND FETCH OVERFLOW TO CONTROL PAGE FORMATTING

RPG II performs automatic page formatting. With standard 66 line forms, it leaves five blank lines at the top of a page and six at the bottom. (Six lines are printed per inch; eight lines per inch are also possible.) However, automatic page formatting may not always meet your needs. If you want control over page formatting, you can use an overflow indicator (OA-OG, OV). For instance, assume that at the end of every month you prepare an inventory report which consists of a list of the quantity of all items in stock by product class. Items are listed by product class, and each product class should start on a new page (Figure 3-1).

Suppose the heading were to start on line 11 of each page. To have an equal margin (ten spaces) on top and bottom, line 56 should be the last printed line on the page (assuming 66 lines per page). For this report, you must use an overflow indicator to control page format.

### Overflow Indicators

Overflow indicators, like other indicators, are used to do two things:

- Signal a certain condition.
- Control when specific operations (including those which control page format) are performed.

For example, in the monthly inventory report, items in stock are listed by product class. The report consists of 46 lines per page (starting line is 11 and ending line 56). Some product classes are going to have more than 46 different items in stock. For these classes, additional pages (overflow pages) are required to list the items.

Normally, the *overflow line* is the last line you want to print on the page. For this report, the overflow line would be line 56. When this line is printed, the overflow indicator (if one is assigned) is turned on to signal that the last line you wished printed on the page has been reached.

When the overflow indicator is on, you know that the overflow line has been reached. At the end of the page, operations, such as advancing to a new page (the overflow page) and printing headings on the new page, can be performed. By assigning and using overflow indicators, you can print special lines at the bottom of the page and at the top of the new page. Because you do these operations only when the overflow indicator is on, you will have to condition these operations by the overflow indicator.

CLASS	ITEM NO	DESCRIPTION	ON HAND
00124	46732J1	SWEATER, V-NK, SZ 32	10
	63241B1	SWEATER, V-NK, SZ 34	16
	43151CK	CARDIGAN, SZ 36	17
IN STOCK AS OF 10/30/71			
-----			
CLASS	ITEM NO	DESCRIPTION	ON HAND
00125	54321K4	T-SHIRT, WH, SZ 30	11
	56422K4	T-SHIRT, WH, SZ 32	14
	57381J4	T-SHIRT, WH, SZ 40	15
	58324B1	T-SHIRT, WH, SZ 42	8
IN STOCK AS OF 10/30/71			
-----			
CLASS	ITEM NO	DESCRIPTION	ON HAND
00126	67341B3	WOOL SOCKS, BL 10	11
	67432B3	WOOL SOCKS, GR 10	9
IN STOCK AS OF 10/30/71			
-----			

Figure 3-1. End-of-Month Inventory Report



### Line Counter Specifications

Line	Form Type	Filename	1		2		3		4		5		6		7		8		9		10		11		12	
			Line Number	FL or Channel Number	Line Number	OL or Channel Number	Line Number	Channel Number	Line Number	Channel Number	Line Number	Channel Number	Line Number	Channel Number	Line Number	Channel Number	Line Number	Channel Number	Line Number	Channel Number	Line Number	Channel Number	Line Number	Channel Number	Line Number	Channel Number
1	L	PRINT	6	6	5	5																				
2	L																									
3	L																									

Figure 3-3. Line Counter Specifications

### File Description Specifications

You must assign an overflow indicator to the *printer file* when you want to control the format of printed reports. This is done by an entry in columns 33-34 of the File Description sheet (Figure 3-4). You may choose to enter any of the following overflow indicators: OA, OB, OC, OD, OE, OF, OG, or OV. The one you choose, however, must be used throughout the program. *L* must also be entered in column 39 to indicate that line counter specifications are used.

These two entries indicate to the RPG II compiler that it should not provide automatic page formatting, but should format according to your specifications. If you do not make an entry in columns 33-34 of the File Description sheet for a printer file, an automatic skip to line 1 occurs on overflow.

### File Description Specification

Line	Form Type	Filename	File Type				Mode of Processing				Device	Symbolic Device	Labels S/N/E/M	Name of Label Exit		Extent Exit for DAM	File Addition/Unordered									
			I/O/U/C/D	P/S/C/R/T/D	E	A/D	F/V/S/M/D	Block Length	Record Length	L/P				A/P/I/K	I/D/T or 2		Record Address Type	Key Field Starting Location	Key Field Location	Overflow Indicator	Extension Code E/L	Option	Entry	A/U	R/U/N	Number of Tracks for Cylinder Overflow
02	F	CARDS																								
03	F	PRINT	I																							
04	F		O																							
05	F																									
06	F																									
07	F																									
08	F																									
09	F																									
10	F																									
	F																									
	F																									

Different device names could be used here, depending on your system configuration and model. The device name for the Model 6 printer would be TRACTR1.

Figure 3-4. Assigning an Overflow Indicator to the Printer







This is not the best solution, however. Suppose overflow was caused by the second total record instead of the detail record. Only one more total line would be printed before forms advanced. Much of the page is not used in this case since the last line is printed on line 50 (see Figure 3-8). As you see, this is a very uneconomical solution since much paper can be wasted.

### Fetch Overflow

RPG II provides you with a better solution for preventing printing over the perforation than the one previously discussed. This solution uses the RPG II routine known as *fetch overflow*. Fetch overflow specifications allow you to alter the basic RPG II overflow logic (see *Overflow Indicator, Chapter 1*). You can cause forms to advance at the time total or detail records are printed, instead of waiting

for the usual time. Figure 3-9 shows the two additional times when operations conditioned by the overflow indicator may be performed. (Remember that forms advance at this time.)

During the regular program cycle, the RPG II program tests only once to see if the overflow indicator is on; this occurs immediately after total output. By using the fetch overflow specification, you can tell the computer to check if the overflow indicator is on before it prints total or detail records. You do this by simply entering an F in column 16 of the Output-Format sheet for any detail or total record. When an F is encountered, a test is made before that line is printed.

If the overflow indicator is on when the test is made, all operations conditioned by the overflow indicator are immediately performed. These operations usually include forms advancement and the printing of headings. In order for the line to be printed, all other indicator conditions tested for on the same line as the overflow indicator must also be satisfied.

The diagram shows a page with lines numbered 36 to 66. The following table represents the data on these lines:

Line	Value
36	
37	78.45
38	
39	168.17
40	
41	
42	755.67
43	
44	
45	
46	4,989.72
47	
48	
49	
50	13,421.67
51	
52	
53	
54	
55	
56	
57	
58	
59	
60	
61	
62	
63	
64	
65	
66	

An arrow points to line 46, which is labeled "Overflow line".

Figure 3-8. Specifying the Overflow Line High on the Page

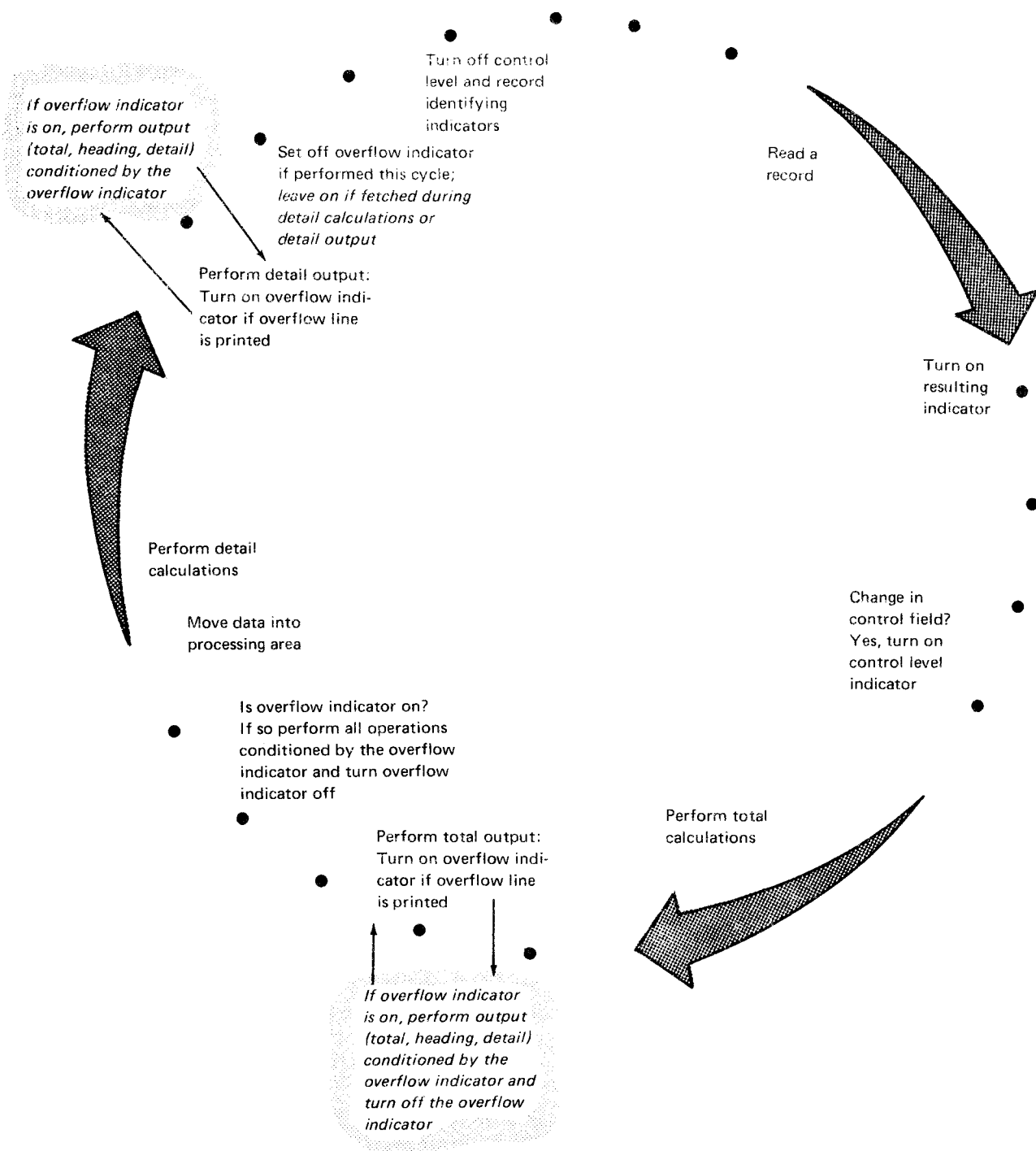

Figure 3-9. Logic for Fetch Overflow

Figure 3-10 shows two fetch overflow specifications (lines 07 and 09). Consider how these operations are performed. When it is time for the specification in line 07 to be done, a test is made to see if the overflow indicator is on. If it is on, the overflow routine is fetched; this causes the following operations to be performed.

1. All total lines conditioned by the overflow indicator are printed.
2. Forms are advanced (provided a skip to a new page has been specified in a line conditioned by the overflow indicator).
3. Heading lines conditioned by the overflow indicator are printed.
4. The overflow indicator is turned off.
5. The record specified in line 07 is printed.

Another test is made to see if the overflow indicator is on because of the specification (F) in line 09. If line 07 causes forms to advance, the overflow indicator would not be on at this time. The total record specified in specification line 09 would be printed normally.

However, if the record specified in line 07 were printed on the overflow line, the overflow indicator would be on and the specification in line 09 would cause the overflow routine to be performed.

Consider again the example as shown in Figure 3-6. When the detail line was printed on the overflow line, all total lines were also printed before forms advanced. As a result, printing occurred over the perforation onto the next page (Figure 3-7).

What records should most logically be printed on an overflow page? Your answer is probably all those records that printed on or over the perforation. It would indeed be nice if all total records could be printed on the next page when a detail record was printed on the overflow line (see Figure 3-11).

If the program knew before it printed the first total record that the overflow line had been reached, forms could be advanced before the total records were printed. By specifying an F in column 16 of the first total specification, you can tell the program to check to see if the overflow indicator is on. If it is on at this time, forms will advance before total records are printed. Specifying an F in column 16 of the first total specifications will cause all total records to be printed on an overflow page.

Would an F for the first total line take care of all situations? Suppose that overflow did not occur until the first total record was printed. The remaining total lines, having no fetch overflow specification in column 16, would not cause the program to check to see if the overflow indicator was on. Thus, they would be printed on the same page (Figure 3-12). Counting the spaces, this would mean the last print line would be eight lines beyond 58 (the overflow line) or on line 66.

If this is feasible for your report, you could allow printing on line 66. If not, you could have the overflow indicator checked at the second total line. In this case, if the first total line caused the overflow indicator to turn on, the second total line would fetch the overflow routine. Thus, the last total records would be printed on the overflow page.

How can you determine on which line to place the F that will fetch the overflow routine (provided the overflow indicator is on)? You should study all possible overflow situations. By counting spaces and lines, you can calculate what would happen if overflow occurred on each detail and total line. This is essentially the method used in the previous discussion.

IBM International Business Machine Corporation																																				
Program																		Punching Instruction			Graphic															
Programmer																		Date			Punch															
Line	Form Type	Filename	Type (M/D/T/E)	Stacker # / Fetch (F)	Space	Skip	Output Indicators	Field Name																												
								And	And																											
					Before	Alter	Before	Alter	Not	Not	Not	Not	Not	Not	Not	Not	Not	Not	Not	Not	Not	Not	Not	Not	Not	Not	Not	Not	Not	Not	Not	Not	Not	Not	Not	*AUTO
01	O	PRINTER	H			ØL																														
02	O		R			2																														
03	O																																			
04	O		D			2																														
05	O																																			
06	O																																			
07	O		F			2																														
08	O																																			
09	O		F																																	
10	O																																			

An F in column 16 causes the computer to test to see if the overflow indicator is on.

Figure 3-10. Fetch Overflow Specifications

54	JOE BROWN	409.10
55		
56		78.40
57		
58		168.17
59		
60		
61		
62		
63		
64		
65		
66		
Page 2		
		755.67
		4,989.72
		13,421.67

Figure 3-11. Printing Total Records on the Overflow Page

		168.17
		755.67
61		
62		
63		4,989.72
64		
65		
66		13,421.67

Figure 3-12. Printing on the Last Line on the Page

## ALIGNING FORMS

Regardless of the type of printing forms you are using, it is always necessary to have the forms aligned so that printing is done *on* the correct line. If printing occurs above or below the line, your report looks messy and is hard to read.

How can you be sure the first line will be printed in the correct position? You can align the forms in the position you feel is correct. But you can never be sure until you try. To try the alignment, the program must be executed; a record must be printed. Suppose the forms are incorrectly aligned, and as a result, the first printing line is incorrectly positioned. In this case, you can stop the computer and realign the forms so that, hopefully, the second line will be correct. This can go on for several tries, however. In the meantime, the first few records printed on the report will have been incorrectly aligned.

RPG II has the facility to print the first line repeatedly until forms are aligned properly. This eliminates printing the first several lines of a report before correct forms alignment is attained. The use of this facility requires two specifications:

1. An output line conditioned by the 1P indicator.
2. The entry of 1 in column 41 of the control card.

When these specifications are made, the first line conditioned by the 1P indicator is printed. All processing then stops. The operator has time to reposition the forms if necessary. When this is done, the operator has the option of having the 1P line printed again or of continuing processing. This he indicates by specific settings of the console switches on the processing unit. (See halt 1P in the *IBM System/3 Models 8 and 10 Halt Guide*, GC21-7540 for a complete description of the alignment process.)

All space and skip entries specified for the 1P line are performed when forms are being aligned. This should be considered in planning for forms alignment.

If spooling printed output on the Model 15, the 1P forms alignment option will be ignored and the user can request alignment by means of the OCL PRINTER statement.

## EDITING

Formatting a printed report is one way of making the report easy to read and understand. Formatting, however, concerns only the spacing and arrangement of data on the printed page. It does not concern the data itself. Data must also be readable before the report can be understood. Editing makes a field readable.

When fields are printed out according to basic specifications they appear exactly as they are inside the computer. This is shown by the following examples:

Type of Field	Field Before Printing	Field After Printing
Alphameric	JOHN T SMITH	JOHN T SMITH
Numeric	004765K	004765K

The alphameric field, when printed, is easy to read and understand, but the numeric field is confusing. How should it be read? What does the K mean? K is actually a combination of a digit and the sign of the field. But in this form, the reader would have to guess what it says (see *Character Structure in Working With Data Structure* for more information).

Editing is the means by which data is made more readable and understandable. Editing a field means punctuating it by removing the sign of the field from the rightmost digit and placing it at the end of the field, adding commas, decimal points, minus signs, dollar signs, or any other constant information.

Only numeric fields need to be edited before they are printed. Notice the difference between the following edited and unedited data taken from the same numeric amount field:

004765K	unedited data
\$476.52CR	edited data

The edited amount field is certainly much more precise and understandable than the unedited field.

### Methods of Editing

A field can be edited by two methods: (1) edit codes and (2) edit words. Several different codes are available. Each code edits in a slightly different way according to a pre-defined pattern. All, however, remove the sign of the field so that the rightmost digit will always print as a number. (See *Character Structure in Working With Data Structure* for more information.) The Y edit code is used for date fields only.

Figure 3-13 shows the edit pattern for all codes. Choose the code which will edit a field the way you want it to appear and enter this code in column 38 of the Output-Format sheet.

Edit Code	Commas	Decimal Point	Sign For Negative Balance			Print Out On Zero Balance *			Zero Suppress
			No Sign	CR	- (Minus)	Domestic and United Kingdom	World Trade /	World Trade J	
1	Yes	Yes	No Sign			.00 or 0	,00 or 0	0,00 or 0	Yes
2	Yes	Yes	No Sign			Blanks	Blanks	Blanks	Yes
3		Yes	No Sign			.00 or 0	,00 or 0	0,00 or 0	Yes
4		Yes	No Sign			Blanks	Blanks	Blanks	Yes
A	Yes	Yes		CR		.00 or 0	,00 or 0	0,00 or 0	Yes
B	Yes	Yes		CR		Blanks	Blanks	Blanks	Yes
C		Yes		CR		.00 or 0	,00 or 0	0,00 or 0	Yes
D		Yes		CR		Blanks	Blanks	Blanks	Yes
J	Yes	Yes			-	.00 or 0	,00 or 0	0,00 or 0	Yes
K	Yes	Yes			-	Blanks	Blanks	Blanks	Yes
L		Yes			-	.00 or 0	,00 or 0	0,00 or 0	Yes
M		Yes			-	Blanks	Blanks	Blanks	Yes
X **									
Y ***									Yes
Z									Yes

\* Zero balances for the World Trade format are written in two ways, depending on the entry made in column 21 of the control card specifications.

\*\* The X code performs no editing.

\*\*\* The Y code is used for date fields. It suppresses the leftmost zero only. The Y code edits a three to six digit field according to the following pattern:

nn/n  
 nn/nn  
 nn/nn/n  
 nn/nn/nn

If a data field of six digits is packed on disk and the Y edit code is used with the data field, an error will occur. To solve this problem, move the data field to another field.

Figure 3-13. Edit Codes



For example, if you wish a field called AMOUNT which has two decimal positions to be zero suppressed and punctuated with decimal points and commas (when needed) but with no sign, you choose the code that will do this. The chart in Figure 3-13 shows that two codes will accomplish this—1 and 2. If you wish a zero balance to print, you would choose the code 1. If you wanted blanks to print when the field is zero, you would use the 2 code.

Using edit codes is a convenient way of editing. However, the codes by themselves can't do everything you might want to do.

**Punctuating With a Dollar Sign**

Suppose you wanted a dollar sign to be printed on the report for the AMOUNT field. An edit code won't put the dollar sign there. You will have to specify this in addition to the edit code you are using.

According to the printer spacing chart (Figure 3-14), the AMOUNT field is six characters long. It begins in column 70 and ends in column 75. However, the minus sign would extend the amount field to column 76, as shown in Figure 3-15 and Figure 3-16. The dollar sign, if printed, should be in column 69. Line 11 in Figure 3-15 shows the specification for editing the AMOUNT field by the edit code J. This code is used so that negative values will print with a minus sign (-) following the field. The dollar sign can be specified as a constant ending in column 69 and must be specified in line 12, the line following the edit code.

Depending upon its contents, the AMOUNT field, when printed out, could look like any of the following (where N is any number):

\$NNN.NN  
 \$ NN.NN  
 \$ N.NN  
 \$ .NN

The blanks between the first digit and the dollar sign are the result of zero suppression. The dollar sign remains in position 69: this is known as a *fixed dollar sign*.

Often, it is desirable, as in writing checks, to eliminate these empty spaces. There are two ways of doing this: (1) moving the dollar sign so that it is always next to the first digit; and (2) filling the spaces with asterisks.

Instead of having blanks between the dollar sign and the first digit, you can cause the dollar sign to print next to the first digit. In this case, the amount field would look like one of the following:

\$NNN.NN  
 \$NN.NN  
 \$N.NN  
 \$.NN

A dollar sign that changes positions is known as a *floating dollar sign*. It is specified by placing the entry 'S' in columns 45-47 on the same specification line as the edit code (see Figure 3-16). Remember that the fixed dollar sign was specified by placing \$ in columns 45-47 of the line following the edit code (Figure 3-15).

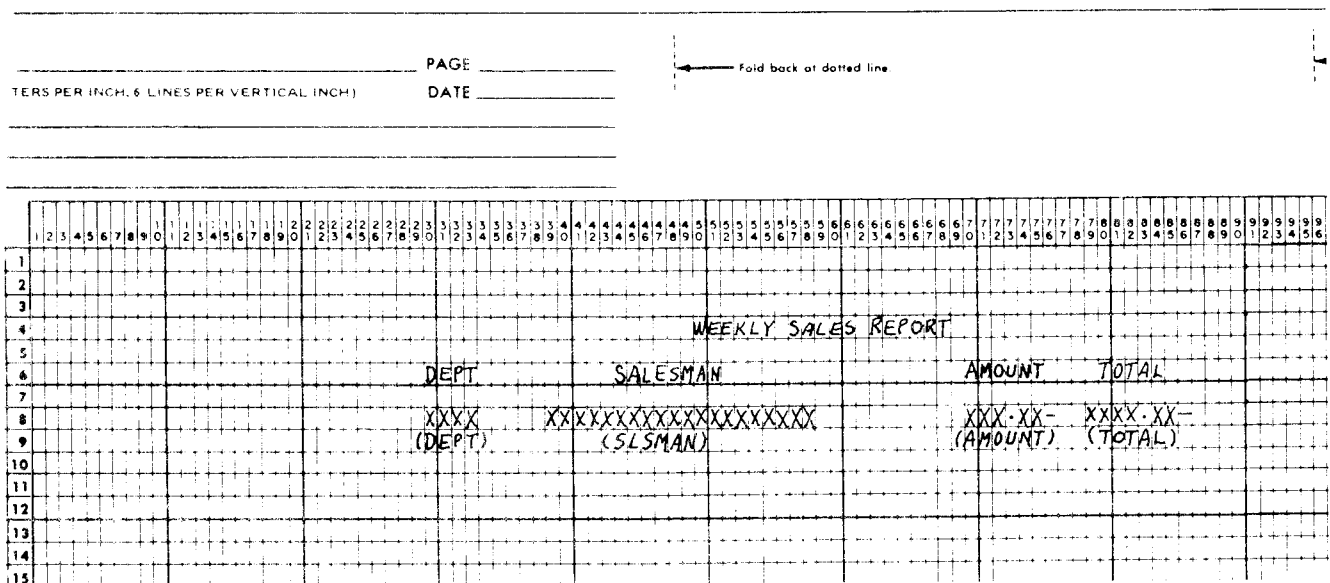

Figure 3-14. Printer Spacing Chart (Editing)



**Punctuating With Asterisks**

To indicate that asterisks should fill the spaces caused by suppression of leading zeros, place the entry '\*' in columns 45-47 of the same specification line as the edit code. If a dollar sign is to appear before the asterisk, it must be specified on the next line. With the specifications shown in Figure 3-17, the AMOUNT field, depending upon its contents, could look like any of the following:

- \$NNN.NN
- \$\*NN.NN
- \$\*\*N.NN
- \$\*\*\*.NN

Refer to the *IBM System/3 RPG II Reference Manual*, SC21 7504 for a more detailed explanation and further considerations.

**Punctuating With Dashes**

What code would you use for the following job? A report listing all employee names, addresses, telephone numbers, and social security numbers, is desired. A file is kept on all employees. Each record includes one employee name, address, telephone number, and social security number among other things.

The telephone number and social security number are entered in the record as one continuous number with no dashes. Remember that fields will print out exactly as they are recorded. Thus the telephone number will appear as 2820804. This is rather hard to read. 282-0804 is much better. How will you get the dash to appear?

A dash is a type of punctuation. So some type of editing must be done. Can you find a code that will edit this way? No, there is none available.

For this case, you will have to set up your own editing pattern. An *edit word* gives a pattern for punctuation. For the phone number you need three digits, a dash, and then four digits. You specify the edit word in columns 45-70 of the Output-Format sheet. The word, like any constant, must be enclosed in quotes. Figure 3-18, line 04, shows how the telephone number field is edited: three blanks, a dash, and four blanks.

Unless the social security field is also edited, it will print out in one long string of numbers, such as 472446357. Form the edit word to make the social security number read: 472-44-6357. It should look like the edit word shown in Figure 3-19, line 05. Notice that a leading 0 (zero) is included in the edit word in addition to the number of places required for the data. This prevents zero suppression when the SOCSEC field is edited.

IBM		RPG OUTPUT SPECIFICATIONS		Page 1 of 5	
Program	Running on this Job	Editable	Card Edit Code	75	26 2 74 29 84
Programmer	Date	Ready		Program	Line Number
0	Label	Special	Skips	Output indicators	Field Name
01	PRINTER	H	204	OV	
02	OR			IP	
03					
04	H		2	OV	68 'WEEKLY SALES REPORT'
05	OR			IP	
06					
07					
08					
09					
10					
11		D	L	OL	
12					
13					
14					
					AMOUNTJ
					75 '*'
					69 '\$'

To fill empty spaces caused by zero suppression with asterisks, place '\*' in columns 45-47 of the same line as the edit code.

Figure 3-17. Punctuating with Asterisks

IBM		RPG OUTPUT SPECIFICATIONS										GX21-9090 U/M 050*			
International Business Machine Corporation												Printed in U.S.A.			
Program										Punching Instruction		Graphic		Card Electro Number	
Programmer										Date		Punch			
										Page 1 2 of		Program Identification 75 76 77 78 79 80			

Line	Form Type	Filename	Type (H/D/T/E)		Space		Skip		Output Indicators			Field Name	Edit Codes	End Position in Output Record	P/B/L/R	Commas	Zero Balances to Print	No Sign	CR	-	X = Remove Plus Sign
			A	N	D	E	Before	After	Before	After	Not										
01	O	PRINTER	D	L																	
02	O											NAME		30							
03	O											ADDR		50							
04	O											TELE		60							
05	O																				

Figure 3-18. Edit Word for Telephone Number

IBM		RPG OUTPUT SPECIFICATIONS										GX21-9090 U/M 050*			
International Business Machine Corporation												Printed in U.S.A.			
Program										Punching Instruction		Graphic		Card Electro Number	
Programmer										Date		Punch			
										Page 1 2 of		Program Identification 75 76 77 78 79 80			

Line	Form Type	Filename	Type (H/D/T/E)		Space		Skip		Output Indicators			Field Name	Edit Codes	End Position in Output Record	P/B/L/R	Commas	Zero Balances to Print	No Sign	CR	-	X = Remove Plus Sign
			A	N	D	E	Before	After	Not	And	And										
01	O	PRINTER	D	L																	
02	O											NAME		30							
03	O											ADDR		50							
04	O											TELE		60							
05	O											SOCSEC		75							

Figure 3-19. Edit Word for Social Security Number

### Punctuating by Leaving Blanks

A company has rather long account numbers. To make them easier to read and handle, blanks are left after every third digit when the number is printed.

Is there a code that will insert blanks? No, again you have to specify your own edit word. In an edit word, blanks indicate where the digits go and *ampersands* indicate where blanks will go. The account field consists of ten digits. The edit word shown in Figure 3-20, insert A, will put blanks after every three digits.

### Punctuating by Adding Constant Information

For shipping purposes, the catalog department of a department store must know the weight of every item it sells. The weight in pounds and ounces is recorded in a 6-digit field. The last two digits are ounces, the first four digits are pounds. When printed out on a report, the constants LBS and OZ must be inserted. Otherwise, the data would not be understandable. Again to do this, an edit word is needed because no edit code will insert LBS and OZ.

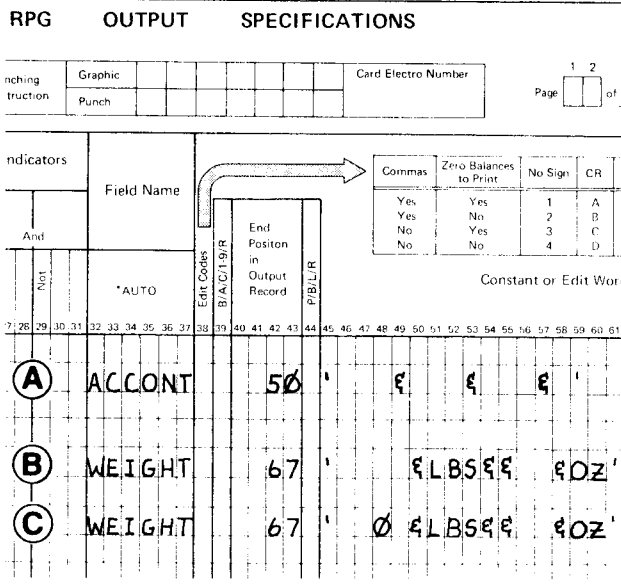

Figure 3-20. Edit Words

The printed field is shown on the printer spacing chart in Figure 3-21. One space is needed between the digit and LBS and between the digit and OZ. Two spaces separate pounds from ounces. Remember in the edit word, blanks are specified for digits, ampersands are specified for blanks; and constant information is inserted where desired. The edit word should be as long as the field shown on the printer spacing chart. Figure 3-20, insert B, shows the correct edit pattern for this field.

ID: \_\_\_\_\_ PAGE \_\_\_\_\_  
 CHARACTERS PER INCH, 6 LINES PER VERTICAL INCH DATE \_\_\_\_\_  
 ← Fold back at dotted line →

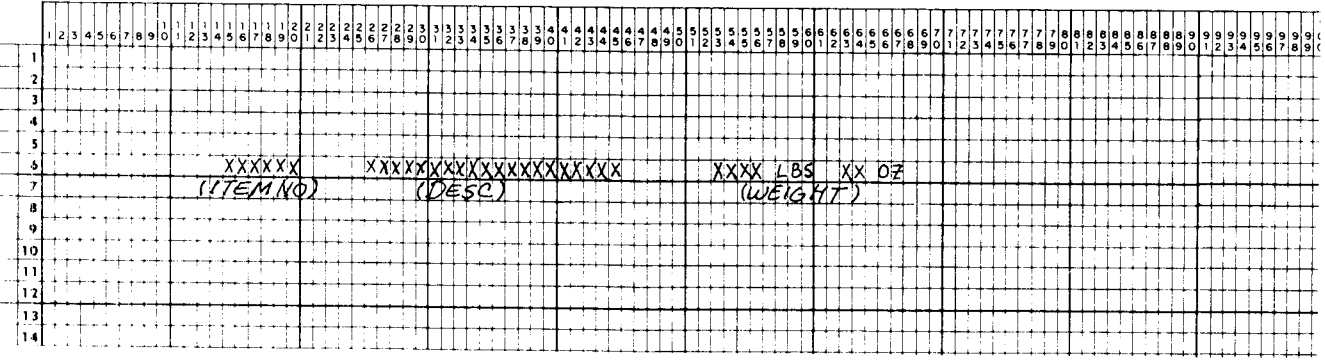

Figure 3-21. Print Chart (Weight Field)

Edit words can do all kinds of editing for you. They can even be set up to do the same thing as the edit codes. All you have to do is *show* where the commas, decimal points, credit signs, etc. should appear. A zero is used to indicate where zero suppression stops. For example in Figure 3-20, insert C, the 0 shows where zero suppression is to end in the WEIGHT field.

Edit codes are a faster and more convenient way of editing than edit words. Therefore, edit words are normally used only when edit codes alone cannot accomplish the job.

### Editing and End Position

When specifying end positions for fields which are to be edited, either by edit words or edit codes, be sure to allow enough room for the edited field. If the field to be edited is six characters long on the input record, do not allow only six positions for it on the printed report. By the time the field is edited, it may contain many more characters than six. For example, the WEIGHT field which is to be punctuated with the constants LBS and OZ is only a 6-character field on the input card. But when printed out after editing it requires 15 spaces. Always specify an end position on the Output-Format sheet (columns 40-43) that takes into account the length of the *edited* field.

### USING \*PLACE TO PRINT DUPLICATE INFORMATION

Using \*PLACE, you can tell the RPG II compiler to print duplicate information. When you specify \*PLACE on the Output-Format sheet, the fields listed above it will be printed in a different position on the same line. This eliminates much duplicate coding.

For example, assume that your distribution firm prepares invoices on their data processing system. The invoice (Figure 3-22) sent to each customer consists of two parts: one part the customer keeps, the other he tears off and sends along with his payment. Many fields are common to both parts of the invoice. For example, NAME and CUSTNO (customer number) are printed on the first line of each part. All fields in the fourth line of the report, except for the description (DESC) fields, and all fields in the total line are found in both parts of the invoice. The second part is almost a duplicate of the first.

<u>NAME</u>	<u>NAME</u>
<u>CUSTNO</u>	<u>CUSTNO</u>
	<u>ADDR</u>
	<u>CITY</u>
<u>ITEM NO</u>	<u>ITEM NO</u>
<u>QTY</u>	<u>DESC</u>
<u>PRICE</u>	<u>QTY</u>
<u>AMT</u>	<u>PRICE</u>
	<u>AMT</u>
TOTAL <u>TOT</u>	TOTAL <u>TOT</u>

Figure 3-22. Invoice Form



**RPG OUTPUT SPECIFICATIONS**

GX21-9090 U/M 050\*  
Printed in U.S.A.

---

Program \_\_\_\_\_ Punching Instruction \_\_\_\_\_ Graphic \_\_\_\_\_ Card Electro Number \_\_\_\_\_  
 Programmer \_\_\_\_\_ Date \_\_\_\_\_ Punch \_\_\_\_\_ Page 1 2 of \_\_\_\_\_ Program Identification \_\_\_\_\_

Line	Filename	Type (H/D/T/E)	Space	Skip	Output Indicators						Field Name	End Position in Output Record	Constant or Edit Word
					And	And	And	And	And	And			
01	INVOICE	D	Ø5			MR	ØL				ØL		
02										NAME	25		
03										CUSTNO	36		
04										NAME	75		
05										CUSTNO	86		
06		D	2			MR	ØL			ADDR	75		
08		D	3			MR	ØL			CITY	75		
10		D	L			MR	ØL			ITEMNO	ØØ		
12										QTY	23		
13										PRICE 3	3Ø		
14										AMOUNT3	38		
15										ITEMNO	5Ø		
16										DESC	72		
17										QTY	8Ø		
18										PRICE 3	87		
19										AMOUNT3	97		

**RPG OUTPUT SPECIFICATIONS**

GX21-9090 U/M 050\*  
Printed in U.S.A.

---

Program \_\_\_\_\_ Punching Instruction \_\_\_\_\_ Graphic \_\_\_\_\_ Card Electro Number \_\_\_\_\_  
 Programmer \_\_\_\_\_ Date \_\_\_\_\_ Punch \_\_\_\_\_ Page 1 2 of \_\_\_\_\_ Program Identification \_\_\_\_\_

Line	Filename	Type (H/D/T/E)	Space	Skip	Output Indicators						Field Name	End Position in Output Record	Constant or Edit Word
					And	And	And	And	And	And			
01		T	32			MR	LL			TOT.	3	38	TOTAL'
03										TOT.	3B	85	TOTAL'
04										TOT.	3B	95	'\$'
05										TOT.	3B	88	'\$'

Figure 3-24. Output-Format Specifications for Invoice (Coding Each Field Twice)



### Specifications for Using \*PLACE

\*PLACE is a special RPG II function which can be used to accomplish duplicate printing with less coding. To the RPG II compiler the specification \*PLACE means: Duplicate that part of the line which has been specified and place the duplicated information in a different position on the same line. \*PLACE means a special function is to be performed. You should not use this specification as a field name, since the RPG II compiler will assume you want the preceding field duplicated. When using \*PLACE you first define, for each record, all the fields which are to be duplicated. Give the end position for each field as you normally do. Then enter the word \*PLACE on the line below the fields which are to be duplicated. Figure 3-25 shows the entries for the first detail line of the invoice.

The compiler does not know where to print unless you specify an end position on the \*PLACE entry. In Figure 3-25, the end position given for the \*PLACE entry was 86.

The \*PLACE specification duplicates not only letters but also blank spaces. It will duplicate all the characters (including blanks) from position 1 to the end position specified for a field. These duplicated characters are then placed so that they end in the end position specified for the \*PLACE entry.

When specifying an end position for the \*PLACE entry, you must know exactly where you wish the fields to print. You must also consider the amount of space needed for the printing of *all* characters to be duplicated. Always specify an end position which allows room for the printing of duplicated fields.

A \*PLACE specification must not be conditioned by indicators in columns 23-31. \*PLACE is automatically conditioned by the same indicators that condition the field or fields to be repeated.

### Formation of Print Lines

When System/3 performs printer output, a whole line is printed at once, regardless of how many fields are in that line. Before printing, the whole line is moved to an area of storage exactly as it is to be printed. Data is placed in this storage area one field at a time.

The sequence in which data enters the storage area depends on the sequence that field names are specified on the RPG II Output-Format sheet. The first field recorded on the Output-Format sheet is entered first, then the second, etc. Each field is inserted into the storage area according to its end-position entry on the Output-Format sheet. If you have made conflicting entries in your specifications (for example, one field overlapping another) the last field mentioned is the one that will print in its entirety.

\*PLACE operates in the same way as normal field names. The operations associated with \*PLACE are performed in the sequence \*PLACE is specified on the Output-Format sheet in relation to other output entries.

IBM International Business Machine Corporation			RPG OUTPUT SPECIFICATIONS			GX21 9090 U/M 050* Printed in U.S.A.		
Program		Punching Instruction		Graphic		Card Electro. Number		
Programmer		Date		Punch		Page 1 2 of Program Identification 75 76 77 78 79 80		
Line	Form Type	Filename	Type (H/D/T/E)	Space	Skip	Output Indicators	Field Name	End Position in Output Record
0 1	O	INVOICE	D	205		MR 01		25
0 2	O						NAME	36
0 3	O						CUSTNO	86
0 4	O						*PLACE	
0 5	O							

Commas	Zero Balances to Print	No Sign	CR	-	X = Remove Plus Sign
Yes	Yes	1	A	J	Y = Date
Yes	No	2	B	K	Field Edit
No	Yes	3	C	L	Z = Zero
No	No	4	D	M	Suppress

Constant or Edit Word

Figure 3-25. Output-Format Specifications for First Line of Invoice (Using \*PLACE to Print Fields Twice)

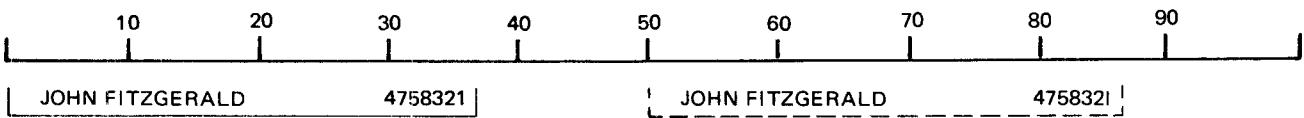

A. Result of field description entries

B. Result of \*PLACE entry

Figure 3-26. Line Formation (First Line of Invoice)

Follow the formation of the first line to be printed on the invoice. According to the specifications in Figure 3-25, the NAME field ends in position 25 and CUSTNO in 36. The first part of the line is completed with these specifications (Figure 3-26, insert A). Because of the way lines are formed, the end position for the \*PLACE entry must be at least two times the higher end position specified for a field that is to be duplicated. This ensures that the last field mentioned will not overlap the field preceding. In this case the same fields are to be printed again on the second part of the same line. Since the end position was 36, the second part of the same line must end at least in position 72 (two times higher than the end position for the field to be duplicated). It is decided they are to end in position 86. The second part of the line is formed by the \*PLACE entry (Figure 3-26, insert B).

Using Different Spacing for Duplicated Fields

The second and third lines of the invoice do not have fields to be duplicated. However, the fourth line of the invoice requires that all fields be duplicated. Notice that different spacing is required for the duplicated fields because a field called DESC must be inserted between ITEMNO and QTY.

Figure 3-27 shows correction specifications. You want to start with ITEMNO since it is the first field. ITEMNO is specified as usual; the end position is given. Then \*PLACE is specified with the correct end position, 50 in this case. These specifications cause the line to look like that in Figure 3-28, insert A.

IBM International Business Machine Corporation			RPG OUTPUT SPECIFICATIONS										GX21 9090 U/M 050* Printed in U.S.A.						
Program		Date		Punching instruction		Graphic		Card Electro Number		Page 1 2 of		Program Identification 75 76 77 78 79 80							
Line	Form Type	Filename	Type I/H/D/T/E	Stacker # / Fetch (F)	Space	Skip	Output Indicators			Field Name	End Position in Output Record	Constant or Edit Word							
			O R A N D	Before After	Before After	Not	And	And				Commas	Zero Balances to Print	No Sign	CR	-	X = Remove Plus Sign	Y = Omit Field Edit	Z = Zero Suppress
												Yes	Yes	1	A	J			
												Yes	No	2	B	K			
												No	Yes	3	C	L			
												No	No	4	D	M			
01	O	INVOICE D								*AUTO									
02	O																		
03	O																		
04	O																		
05	O																		
06	O									ITEMNO	10								
07	O									*PLACE	50								
08	O									QTY	23								
09	O									PRICE 3	30								
10	O									AMOUNT 3	38								
11	O									*PLACE	95								
12	O									DESC	72								

Figure 3-27. Specifications for Fourth Line of Invoice

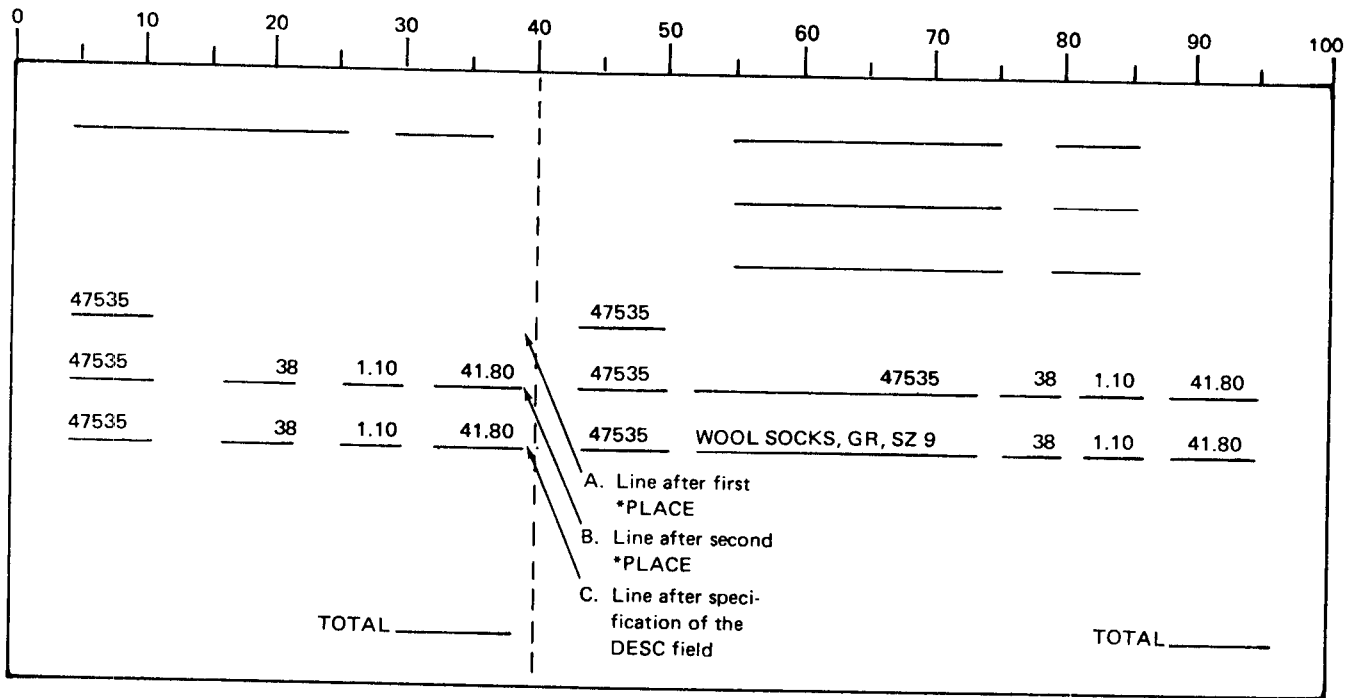

Figure 3-28. Fourth Printed Line

Now, the remaining three fields are specified and an end position is given for each. \*PLACE is entered after them to signify that the above three fields should be duplicated. Remember that when fields are duplicated, all information from position 1 to the highest end position specified for a field is used. In this case, positions 1 through 38 are duplicated and placed so that they end in position 95.

QTY, PRICE, and AMOUNT are in positions 1 through 38, but ITEMNO is also there since it ends in position 10. Thus, all four fields are duplicated and placed so that they end in 96. Figure 3-28, insert B shows resulting formation of the line. ITEMNO now appears three times, once in the DESC field area where it should not be.

In this example, we can specify the field DESC to end in position 75. It will overlay the unwanted ITEMNO field and thus get rid of it. Figure 3-28, insert C shows the line as it will be printed.

For each job you do using \*PLACE, you will have to calculate exactly what happens when lines are formed.

#### Duplicating Constants

\*PLACE can duplicate constants as well as fields. The same specifications are used for both. Figure 3-29 shows the specifications for the last line of the invoice. In this case \*PLACE duplicates a field and two constants. As you can see, using \*PLACE eliminates duplicate coding.

RPG OUTPUT SPECIFICATIONS

GX21-9090 U/M 050\*  
Printed in U.S.A.

**IBM** International Business Machine Corporation

Program	Punching Instruction	Graphic	Card Electro Number
Programmer	Date	Punch	

Page 1 of 2

Program Identification 75 76 77 78 79 80

Line	Form Type	Filename	Type (H/D/E)			Space	Skip	Output Indicators						Field Name	Field Codes	End Position in Output Record	P/B L/R	Constant or Edit Word
			Stacker #	Before	After	Before	Alter	Not	Mix	Run	And	And						
0 1	O	INVOICE D	A	R	D	205		MR										
0 2	O																	
0 3	O																	
0 4	O																	
0 5	O																	
0 6	O																	
0 7	O																	
0 8	O																	
0 9	O																	
1 0	O																	
1 1	O																	
1 2	O																	
1 3	O																	

Commas	Zero Balances to Print	No Sign	CR	-	X	Remove Plus Sign
Yes	Yes	1	A	J	Y	Date Field Edit
Yes	No	2	B	K	Z	Zero Suppress
No	Yes	3	C	L		
No	No	4	D	M		

Figure 3-29. Using \*PLACE to Duplicate Constants (Last Line of Invoice)

### Printing a Field Several Times on the Same Line

\*PLACE can be used to print the same field several times in the line. All you have to do is enter \*PLACE along with an end position for each time you want the fields duplicated. If you want the field duplicated twice, you need two \*PLACE entries.

Assume that periodically a store prepares mailing labels for each customer who has an account with them. They use the labels when they send out special advertisements. The mailing label has only name, address, and zip code on it.

Since the label has to be only a few inches wide, the manager found he could print three labels side by side on his 120-print position printer (Figure 3-30).

You can see that each field needs to be printed three times on each line. In the examples discussed so far, \*PLACE was used to duplicate fields only once.

Figure 3-31 shows the specifications for the first line. NAME needs to be entered three times per line. The original field specification prints it one time: the two \*PLACE entries cause it to be printed two more times.

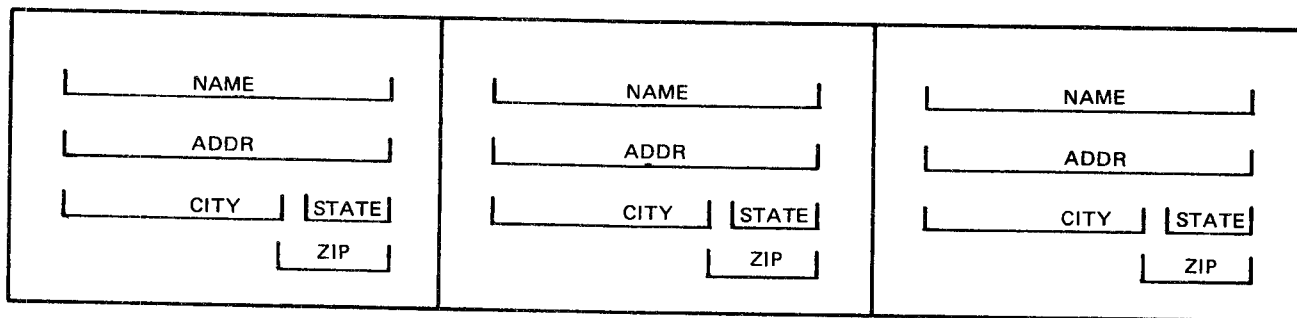
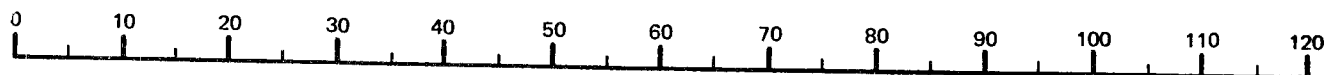

Figure 3-30. Mailing Labels

IBM International Business Machine Corporation			RPG OUTPUT SPECIFICATIONS			GX21-9090 U/M 050*												
Program			Punching Instruction			Card Electro Number												
Programmer			Date			Page 1 2 of												
Program Identification						75 76 77 78 79 80												
Line	Form Type	Filename	Type (H/D/T/E)			Space			Skip			Output Indicators			Field Name	Edit Codes	End Position in Output Record	Constant or Edit Word
			A	D	E	Before	After	Before	After	Not	And	And	Not	Not				
01	O	LABEL		D	32										*AUTO			
02	O														NAME		35	
03	O													*PLACE		75		
04	O													*PLACE		115		

Figure 3-31. Using \*PLACE for Producing Mailing Labels

## USING TWO PRINTER OUTPUT FILES IN ONE PROGRAM

Two System/3 printers, the IBM 5203 Printer on the Model 10 Card and Disk systems and the IBM 2222 Printer on the Model 6 allow you to produce two separate printer output files on the same printer in a program (Figures 3-32 and 3-33). The forms can be narrower than standard forms and are often special forms such as checks or invoices.

A minimum of 17 print positions, between the left carriage tractor and the right carriage tractor, are not available for printing.

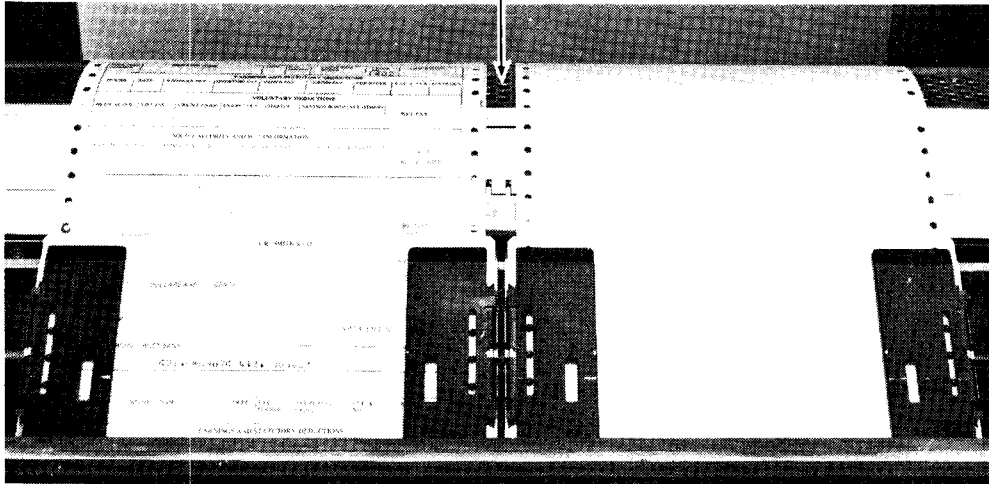

Figure 3-32. 5203 Printer with the Dual Feed Carriage Feature

53958A

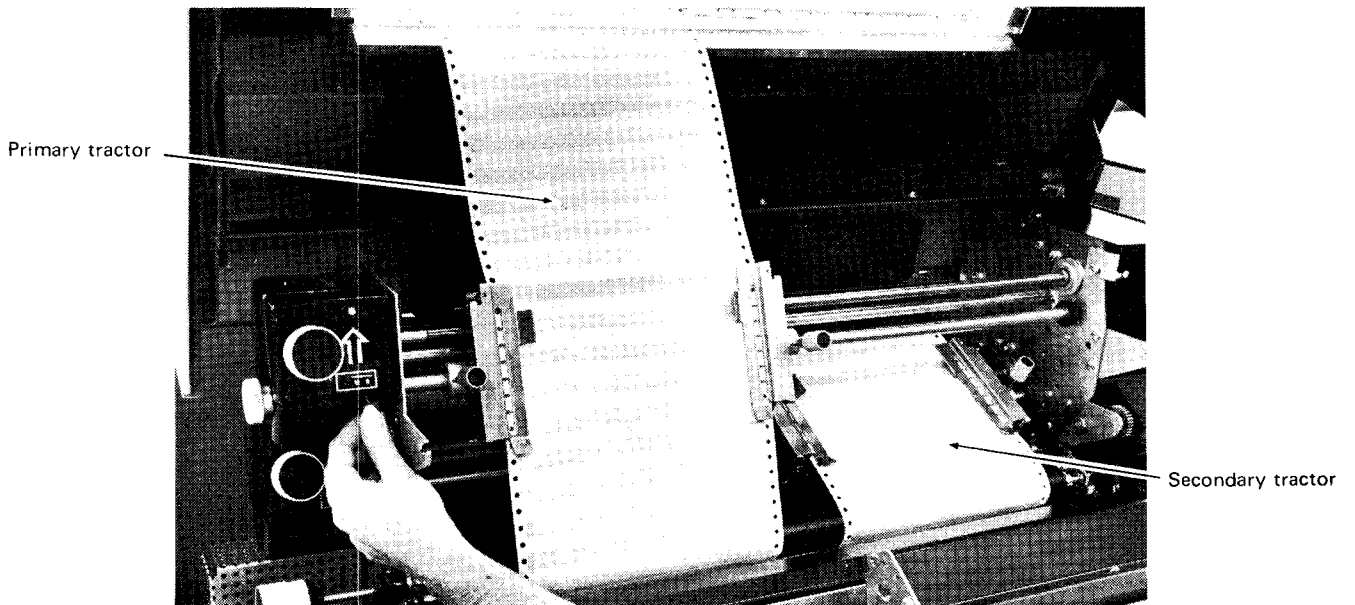

Figure 3-33. 2222 Printer with Dual Feed Tractors

54019A

**Model 10 Card System, Model 10 Disk System, and Model 12**

The feature of the 5203 printer that allows you to produce two separate printer output files is known as the Dual Feed Carriage Feature. The feature is available on 96, 120, and 132 position printers. One form is controlled by the left carriage of the printer and the other form is controlled by the right carriage. There is space between the right and left carriage tractors that contains no form. When you are printing on two forms you lose at least 17 print positions because no forms can be placed in this space (see *Output-Format Specifications*, later in this section).

**Model 6**

The 2222 printer on the Model 6 has dual tractor feeding, a *primary tractor* and a *secondary tractor*. All 220 positions of the printer are available for printing, that is, there need be no positions lost between the primary tractor and the secondary tractor.

The tractors that control the right-hand and left-hand forms on the printer are adjustable. That is, the width of the forms and the starting and ending print positions for each form are variable.

To print two output files for one program, each of the two printer files is considered a separate output file and must be described as such. These output files require special descriptions on the File Description and Output-Format sheets.

**File Description Specifications**

*Model 10 Card System, Model 10 Disk System, and Model 12:* Figure 3-34 is a sample File Description sheet for the Dual Feed Carriage Feature. The two output files to be printed must be assigned to the device names PRINTER and PRINTR2 on the File Description sheet (columns 40-46). PRINTER is the device name for the left carriage of the printer. The right carriage is assigned the device name PRINTR2. Record Length entries (columns 24-27) for the two printer files should be the same. Entries under Block Length (columns 20-23) must be the same as Record Length entries. You are responsible for ensuring that output to the PRINTER device is confined to the left-hand form and output to the PRINTR2 device is confined to the right-hand form. You can easily lay out your two reports using the Printer Spacing Chart.

Line	Form Type	File Type						Mode of Processing				Device	Symbolic Device	Name of Label Exit	Extent Exit for DAM	File Address/Unordered																		
		File Designation	End of File	Sequence	File Format		Length of Key Field or of Record Address Field	Record Address Type	Type of File Organization or Additional Area	Overflow Indicator	Extension Code E/L					Number of Trunks for Cylinder Overflow	Number of Extents		File Condition U1 U8															
					Block Length	Record Length									R/L		A/P/K	I/D/T	R	L	U1	U8												
02	F	INPUT	IP	F	100	100						DISK																						
03	F	OUTPUT1	O	F	132	132						PRINTER																						
04	F	OUTPUT2	O	F	132	132						PRINTR2																						

Figure 3-34. File Descriptions for Two Printer Files on Model 10 Card System, Model 10 Disk System and Model 12 (5203 Printer)

**Model 6:** Figure 3-35 shows the File Description sheet entries for the dual tractors on the 2222 printer. The two printer files are assigned device names TRACTR1 and TRACTR2 on the File Description sheet (columns 40-46). TRACTR1 is the primary tractor (left-hand print unit) and TRACTR2 is the secondary tractor (right-hand print unit). Under Block Length (columns 20-23) for each file enter the *beginning print position* for that file. Under Record Length (columns 24-27) enter the *ending print position* for that file. Print positions for TRACTR1 and TRACTR2 cannot overlap.

**Output-Format Specifications**

Spacing and skipping on the two forms are completely independent. You can specify different spacing and skipping for each output file. Spacing and skipping are entered in columns 17-22 of the Output-Format sheet.

**Model 10 Card System, Model 10 Disk System and Model 12:** Remember, there are 17 print positions you cannot use, because there is a space between the left and right carriage tractors which cannot contain a form. This is important when you are planning where to position your printing on each form. The first character to be printed on the form in the right carriage (PRINTR2) must be *at least* 17 positions away from the last character on the form in the left carriage (PRINTR1). Suppose you decide to use print positions 1 through 80. Because the first character in the right carriage must be at least 17 positions away from the last character in the left carriage, print position 98 is the first available position:

$$80 \text{ (End position of the form in the left carriage)} \\
 + 17 \text{ (Number of print positions you cannot use)} \\
 \hline
 97$$

Therefore, 98 is the first available position. If the length of your print line is 35 characters, the last position for the second form is 132.

File Description Specification																																													
Line	Form Type	Filename	File Type		Mode of Processing										Device	Extent Exit		File Addition/Unordered																											
			File Designation	End of File	Length of Key Field or of Record Address Field		Record Address Type		Type of File Organization or Additional Area		Overflow Indicator		Key Field Starting Location			Extension Code	Number of	Tracks																											
			Sequence	File Format	Block Length	Record Length	L/R	A/P/I/K	I/D/T or 2	Overflow Indicator		Key Field Starting Location		Extension Code	K	Option	Entry	A	U																										
02	F	INPUT	IP	F	100	100																																							
03	F	OUTPUT1	O	F	1	132																																							
04	F	OUTPUT2	O	F	133	220																																							
05	F																																												
06	F																																												
07	F																																												
08	F																																												
09	F																																												
10	F																																												
	F																																												
	F																																												

In this example, TRACTR1 has 132 print positions; the form on the secondary tractor has 88 print positions. All 220 print positions are used in this case, no positions are lost between tractors.

Figure 3-35. File Descriptions for Two Printer Files on Model 6 (2222 Printer)



REYNOLDS INDUSTRIES, INC.  
 111 W. SECOND ST.  
 SAN JOSE, CALIF. 95113

TELEPHONE  
 408-286-9100

CUST. NO.  
 430975

SOLD TO S. W. KINGS  
 498 RIVER STREET  
 SAN JOSE, CALIF. 94067

SHIP TO IMPERIAL DESIGN HOMES  
 DIVISION OF S. W. KINGS  
 8343 BRANCH STREET  
 SUNNYVALE, CALIF. 95117

ORDER DATE	ORDER NO.	SALESMAN	SHIP DATE
7/10/70	13826	G. JONES	7/15/70

QTY.	ITEM NUMBER	DESCRIPTION	UNIT PRICE	EXTENDED AMOUNT
96	391468	OCTAGON BOX 4 INCH	.23	\$ 22.08
40	411116	TWINLITE SOCKET B	.60	24.00
350	411132	SOCKET ADAPTER BRN	.32	112.00
200	411732	SILET SWTCH IVORY	1.20	240.00
175	511117	PULL CORD GOLD	.42	73.50
TOTAL				\$471.58

INVOICE REGISTER  
 7/15/71

INVOICE NO.	CUST. NO.	EXTENDED AMOUNT	DISC. AMOUNT	INVOICE AMOUNT
13826	430975	\$ 471.58	\$	\$ 471.58
13827	431030	238.96	4.78	234.18
13828	432450	57.70		57.70
13829	434960	208.62	4.17	204.45
FINAL TOTALS		\$12,263.97	\$145.29	\$11,118.68

Figure 3-36. Sample Invoice and Invoice Register

**Example: End-of-the-Month Billing**

Assume that your company invoices its customers using your data processing system. It is your responsibility to prepare and print the invoices to be sent to the customers. You are also going to keep an invoice register; a record of every invoice that is sent out. Since you have a dual feed printer, you will print both the invoice and the invoice register at the same time. You might name your two output files INVOICE and INVREG.

The format of your output must be determined. In this case, INVREG will have the standard length of 66 lines, while INVOICE will have a nonstandard form length of 50. Heading information is printed on the top of each report. INVOICE uses a preprinted form for much of its heading information. INVOICE has a 63 print position line and INVREG has a 50 print position line. Figure 3-36, insert A is a sample invoice and Figure 3-36, insert B is a sample invoice register.

Since INVOICE has a nonstandard form length, it must be defined on the Line Counter sheet. You will use line 43 as the overflow line. Figure 3-37 shows a sample Line Counter sheet. (Note that since INVREG has a standard form length, it does not have to be defined on the Line Counter sheet.)

**Line Counter Specifications**

L	Line	Line Type	Filename	1		2		3		4		5		6		7		8		9		10		11		12		
				Line Number	FL or Channel Number	Line Number	OL or Channel Number	Line Number	Channel Number	Line Number	Channel Number	Line Number	Channel Number	Line Number	Channel Number	Line Number	Channel Number	Line Number	Channel Number	Line Number	Channel Number	Line Number	Channel Number	Line Number	Channel Number	Line Number	Channel Number	Line Number
1	1	L	INVOICE	05	01	04	01																					
1	2	L																										
1	3	L																										

**Figure 3-37. Line Counter Specifications for INVOICE**



Overflow and Fetch Overflow

1. When you are not using overflow indicators or line counter specifications, but are allowing RPG II to handle overflow automatically, how many lines are assumed per page? What is the first line printed? What is the overflow line?
2. Code the line counter specifications which are necessary to define a form of 50 lines with the overflow line 8 lines from the bottom. What entries must also be made on the File Description sheet?
3. When is the overflow indicator turned on and when is it tested?
4. Describe a situation where printing can occur below the overflow line.
5. How does the fetch overflow specification alter the normal program cycle?
6. Given the following information, supply the Fetch specifications, for the output shown in Figure 3-40, which will prevent printing records on or over the perforation.
  - Number of printing lines per page is 66. The overflow line is 58.
  - There are seven total lines in all. Since all are conditioned by the same control level indicator, they will all print when a level 1 control break occurs.
  - Overflow should be forced if the overflow line is printed *prior* to beginning total output.
  - Total lines 1, 2, and 3, must print on the same page. Total lines 4 through 7 must print on the same page.

**RPG OUTPUT SPECIFICATIONS** GX21-9090 U/M 650\*  
Printed in U.S.A.

IBM International Business Machine Corporation

Program				Punching Instruction				Graphic				Card Electro Number			
Programmer				Date				Punch				Page 1 2 of Program Identification 75 76 77 78 79 80			

Line	Form Type	Filename	Type (H/D/I/E)		Space	Skip	Output Indicators			Field Name	Edit Codes	End Position in Output Record	P/B/L/R
			O	R			And	And	Not				
01	O	PRINTER	T	3			L			*AUTO			
02	O						L			TOTAL	L	80	
03	O		T	2			L			TOTAL	L	80	
04	O						L			TOTAL	L	80	
05	O		T	12			L			TOTAL	L	80	
06	O						L			TOTAL	L	80	
07	O		T	12			L			TOTAL	L	80	
08	O						L			TOTAL	L	80	
09	O		T	2			L			TOTAL	L	80	
10	O						L			TOTAL	L	80	
11	O		T	2			L			TOTAL	L	80	
12	O						L			TOTAL	L	80	
13	O		T	1			L			TOTAL	L	80	
14	O						L			TOTAL	L	80	

Commas	Zero Balances to Print	No Sign	CR	-	X	Remove Plus Sign
Yes	Yes	1	A	J	Y	Date
Yes	No	2	B	K	Z	Field Edit
No	Yes	3	C	L	Z	= Zero Suppress
No	No	4	D	M		

Constant or Edit Word

● Figure 3-40. Total Specifications (Question 6)

### Forms Alignment

7. Why is accurate forms alignment important?
8. What entries must be made in the RPG II specification sheets to repeat printing the first heading line of a report until the forms have been correctly aligned?

### Editing

9. Choose the correct edit codes for the following punctuation.
  - a. 1,342,650.00CR (for zero balance, print .00)
  - b. 1,246,900– (for zero balance, leave the field blank)
  - c. 1694824.25– (for zero balance, leave the field blank)
  - d. 12/13/71
10. Construct an edit word for a 12-digit account number so that it will print out with the format XXX XXX XXX XX-X.
11. On the Output-Format sheet, specify the edit code and any other entries necessary to print out a dollar amount with the format \$\*\*1,234.56CR. The field must end in position 50. If the field is zero, print 00.

**\*PLACE**

12. What is the function of \*PLACE?
13. In the example shown, is \*PLACE used correctly? If not, why not?

RPG OUTPUT SPECIFICATIONS																														GX21-9090 U/M 050* Printed in U.S.A.						
Program						Punching Instruction						Graphic						Card Electro Number						Page 1 2 of		Program Identification 75 76 77 78 79 80										
Programmer						Date						Punch																								
Line	Form Type	Filename	Type LH/D/TEI		Space	Skip		Output Indicators			Field Name	Edit Codes	End Position in Output Record	P/B/L/R	Commas				Zero Balances to Print		No Sign		CR		-		X = Remove Plus Sign		Y = Date Field Edit		Z = Zero Suppress					
			O	A		Before	After	Not	And	And					Not	Yes	No	1	2	A	J	Yes	No	3	4	C	D	M	Y	Z	Y	Z				
01	O	PRINT	D								*AUTO																									
02	O										NAME		26																							
03	O										ACCTNO		37																							
04	O										*PLACE		70																							

14. Write the output specifications to print two mailing labels in a row using \*PLACE. The first label ends in print position 25, the second in 60. Each mailing label will have three lines and look like this:

```

NAME      (25 characters)
ADDR1     (25)
ADDR2     (18)      ZIPCODE   (5)
    
```

**Dual Printer Output Files**

15. What does the use of the dual feed printer allow you to do?
16. What limitations exist when designing forms for use with the Dual Feed Carriage Feature on the 5203 printer?
17. How do you distinguish between the two feeds on the RPG II specification sheets?

### Answers To Review 3

1. Sixty-six lines are assumed per page. First line printed is 06 and the overflow line is 60.
- 2.

File Description Specification																																																																									
Line 3 4 5	Form Type 6	File Type 7 8 9 10 11 12 13 14							Mode of Processing 15 16 17 18 19 20 21 22 23 24 25 26 27 28 29 30 31 32 33 34 35 36 37 38 39											Device 40 41 42 43 44 45 46	Symbolic Device 47 48 49 50 51 52	Label S/N/E/M 53	Name of Label Exit 54 55 56 57 58 59					Extent Exit for DAM 60 61 62 63 64 65	Core Index 66	File Addition/Unordered 67 68 69 70 71 72 73 74																																											
		V/O/U/C/D 15	P/S/C/R/T/I/D 16	E 17	A/D 18	F/V/S/M/I/D 19	Block Length 20	Record Length 21	L/R 28	A/P/L/I/K 29	I/D/T or 2 30	Record Address Type 31	Type of File Organization or Additional Area 32	Overflow Indicator 33	Key Field Starting Location 34	Extension Code E/L 39	Continuation Lines K	Option 54	Entry 59				A/U 66	Number of Tracks for Cylinder Overflow RU/N 68	Number of Extents Tape Rewind U1 U8 70																																																
0	2	F	PRINT							96											L	PRINTER																																																			

Line Counter Specifications																																																																									
Line 3 4 5	Form Type 6	Filename 7 8 9 10 11 12 13 14												1		2		3		4		5		6		7		8		9		10		11		12																																					
		Line Number 15	F.L or Channel Number 16	Line Number 17	O.L or Channel Number 18	Line Number 19	Channel Number 20	Line Number 21	Channel Number 22	Line Number 23	Channel Number 24	Line Number 25	Channel Number 26	Line Number 27	Channel Number 28	Line Number 29	Channel Number 30	Line Number 31	Channel Number 32	Line Number 33	Channel Number 34	Line Number 35	Channel Number 36	Line Number 37	Channel Number 38	Line Number 39	Channel Number 40	Line Number 41	Channel Number 42	Line Number 43	Channel Number 44	Line Number 45	Channel Number 46	Line Number 47	Channel Number 48	Line Number 49	Channel Number 50	Line Number 51	Channel Number 52	Line Number 53	Channel Number 54	Line Number 55	Channel Number 56	Line Number 57	Channel Number 58	Line Number 59	Channel Number 60	Line Number 61	Channel Number 62	Line Number 63	Channel Number 64	Line Number 65	Channel Number 66	Line Number 67	Channel Number 68	Line Number 69	Channel Number 70	Line Number 71	Channel Number 72	Line Number 73	Channel Number 74												
L	PRINT	05	05	05	05	05	05	05	05	05	05	05	05	05	05	05	05	05	05	05	05	05	05	05	05	05	05	05	05	05	05	05	05	05	05	05	05	05	05	05	05	05	05	05	05	05	05	05	05	05	05	05	05	05	05	05	05	05	05	05	05	05	05	05	05	05	05	05					

- Form length is 50 lines and overflow line is 42. Any overflow indicator OA-OG or OV must be entered in columns 33-34 of the File Description sheet. L must be entered in column 39 to indicate that Line Counter specifications are used.
3. If the printer has printed on the overflow line either during total or detail output, the overflow indicator specified in the File Description sheet is turned on. The overflow indicator is tested and overflow output performed only after total output.
  4.
    - a. When more than one detail or total line is printed during one cycle and a line other than the last total line is printed on the overflow line.
    - b. When the last detail line for a control group prints on the overflow line, the total lines for that group will print below the overflow line.
  5. The overflow indicator is tested prior to printing each line specified with fetch overflow rather than waiting until all total output has occurred. If the indicator is on when tested, overflow output is performed immediately and then the line specified is printed.





- The A edit code will zero suppress and insert commas, decimal points, and the credit sign CR. The asterisk entered in columns 45-47 will cause all places zero suppressed to be filled with asterisks. The dollar sign must be specified on the line following the edit code. When printed in position 38, it will come right before the asterisks.

IBM		RPG OUTPUT SPECIFICATIONS			GX21-9090 U/M 050*		
International Business Machine Corporation		Printed in U.S.A.					
Program		Punching Instruction		Graphic		Card Electro Number	
Programmer		Date		Punch		Page 1 2 of	
						Program Identification 75 76 77 78 79 80	

Line	Form Type	Filename	Type (H/D/T/E)		Space		Skip			Output Indicators			Field Name	Edit Codes	End Position in Output Record	P/B/L/R	Constant or Edit Word
			O	R	A	D	Before	After	Before	After	Not	And					
01	O												*AUTO				
02	O												AMOUNTA		50	'*	
03	O														38	'\$	
04	O																

- The function of \*PLACE is to easily code the printing of duplicate information on the same output line. \*PLACE places information from print position 1, through the highest end position previously defined for a field into the print positions indicated by the end position in the \*PLACE entry.
- It is not correct. The end position in the \*PLACE specification is not high enough. The duplicated information will overlay the field called ACCTNO. The end position on the \*PLACE line should be at least twice the highest end position previously specified for that record.
- Two labels must be printed. Therefore, for each line you must specify the original field and a \*PLACE entry, which will cause the contents of the original field to be duplicated.

**RPG OUTPUT SPECIFICATIONS**

IBM International Business Machine Corporation GX21-9090 U/M 050\*  
Printed in U.S.A.

Program:		Punching Instruction:	Graphic:	Card Electro Number:
Programmer:		Date:	Punch:	

Page 1 of 2      Program Identification 75 76 77 78 79 80

Line	Form Type	Filename	Type (H/D/T/E)				Space		Skip		Output Indicators			Field Name	Edit Codes	End Position in Output Record	P/B/L/R	Constant or Edit Word
			A	D	T	E	Before	After	Not	And	And	Not	Not					
01	O	PRINT	D	L	O	L									25			
02	O												*PLACE		60			
03	O																	
04	O		D	L									*PLACE		25			
05	O														60			
06	O												ADDR1		25			
07	O		D	L									*PLACE		60			
08	O																	
09	O												ADDR2		18			
10	O												ZIPCOD		25			
11	O												*PLACE		60			
12	O																	
13	O																	
14	O																	
15	O																	
16	O																	
17	O																	
18	O																	
19	O																	
20	O																	

- 15. The dual feed carriage allows the printing of two independent reports simultaneously.
  - 16. A minimum of seventeen print positions must be left blank between the two output forms.
  - 17. *Model 10 Card System, Model 10 Disk System, and Model 12:* The only difference is that the device name on the File Description sheet for the left carriage is PRINTER and for the right carriage is PRINTR2.
- Model 6:* The only difference is that the device name on the File Description sheet for the left tractor is TRACTR1 and for the right tractor is TRACTR2.



**CHAPTER 4 DESCRIBES:**

- Punched output.
- Printing on cards.
- Using one file for both input and output.
- Selecting the stacker for output cards.
- Merging input and output file cards.

**BEFORE READING THIS CHAPTER YOU SHOULD BE ABLE TO DESCRIBE:**

- Using the printer to produce a simple listing.
- Using control fields.
- RPG II object program cycle for detail and total operations.

**AFTER READING THIS CHAPTER YOU SHOULD BE ABLE TO DESCRIBE:**

- Coding for punching a combined or output card file; summary punching.
- Formatted printing and unformatted printing (\*PRINT) on cards.
- Uses and coding for combined files.
- Stacker selecting input, combined, and output card files.
- Coding for merging input and output card files.

*Note:* You can use the review questions contained in *Review 4* at the end of this chapter to test your comprehension of each topic in the chapter. Questions are grouped according to the topic to which they apply. Answers follow the review questions.

## INTRODUCTION

Thus far, in this manual, the program output usually has been a printed form or report. Punched cards generally have been used as a source of input data. However, cards can be used for output as well as input. This chapter describes RPG II coding for output operations using the IBM 5424 MFCU, available on the System/3 Models 10 and 15, and the IBM 2560 MFCM, available on the System/3 Model 15 only.

You might want to have card output for many reasons. Perhaps you want to generate a new file or change an input file in some way, such as by reformatting the records, adding data, deleting data, adding new records, or deleting unwanted records. The output you choose might be data punched on the cards, printed on the cards, or both. Information can be printed on cards for identification, interpretation of the punched data, or any other purpose you desire. You can punch and print data on blank cards or on cards that already contain data. You can also direct cards to a specific stacker or more output file cards with cards from an input file.

## PUNCHING AND PRINTING ON CARDS

Punching and printing on individual output cards are controlled separately. Punched cards need not be printed; printed cards need not be punched.

### Punched Output

Punched output can be used to:

- Create a file of cards that is different from the input card file
- Add new records to a card file
- Add fields to input records
- Punch a summary card from a group of input cards

RPG II coding for punched output is similar to coding for printer output. Either the primary hopper (device name MFCU1 or MFCM1) or the secondary hopper (device name MFCU2 or MFCM2) can be used as the output device; the other hopper is used as the input device. In some cases, punching can be done on the input cards themselves (see *Using One File for Both Input and Output*, in this chapter). Remember, however, if only one MFCU hopper is used, it must be MFCU1 (Model 10 Card System only).

On the Output-Format sheet, you can specify heading, detail, and total output, just as you can with a printer file. In some cases, you may want to punch only total records by summing the data on several input records and punching a separate card for the total. This is known as *summary punching*. Do not specify an edit code for punched output unless you want to have punctuation punched into the output cards.

### Printing On Cards

It is advantageous to print the same information on the card as was punched on the card. This way you can easily interpret what information is recorded on the card. Also, printing information on the card makes it easier to recreate a card that is damaged to the extent that it cannot be read by the MFCU or MFCM, or duplicated by the data recorder.

Although you may print the same information on the card that is punched on the card, it is not always necessary to do so. You may print entirely different fields from those that are punched.

The 96-column card has space at the top for four lines of printing (Figure 4-1). Each line can contain 32 printed characters, for a total of 128 print positions.

The 80-column card can be printed only on the MFCM Model A1 with the optional print feature. Up to six print lines can be used. Each line can contain up to 64 printed characters, for a total of 384 print positions.

The MFCM print heads can be set to print in 25 different print line positions, from above the 12-punch position to below the 9-punch positions (Figure 4-2). The print heads, numbered 1 through 6, must remain in sequence from top to bottom, with print head 1 at the top. Therefore, with six print heads installed, print head 1 cannot be set below line 20 and print head 6 cannot be set above line 6. Intermediate line positions are located on and between each row of punch positions. Print-position 5 (between the 11-row and 0-row) should be avoided, if possible, because the feed wheel may cause some smudging of characters printed in that position. In punched fields, printing in even-numbered line positions should be avoided because punching may obliterate some characters.

### Formatted Printing (MFCU)

Using formatted printing, you may print a field or constant in any of the 128 print positions available on a 96-column card. The first three lines are the lines usually printed. The fourth is printed only if necessary because printing on the fourth line increases considerably the amount of time needed to print, and thus increases the time needed to do the job.

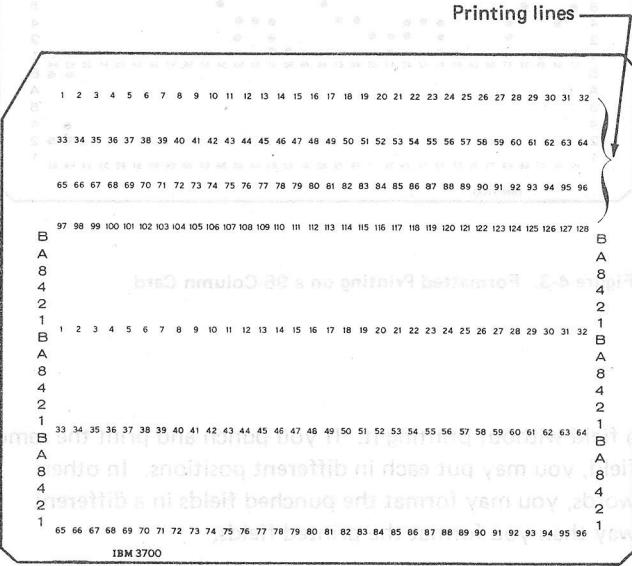

Figure 4-1. Printing Lines on a 96-Column Punch Card

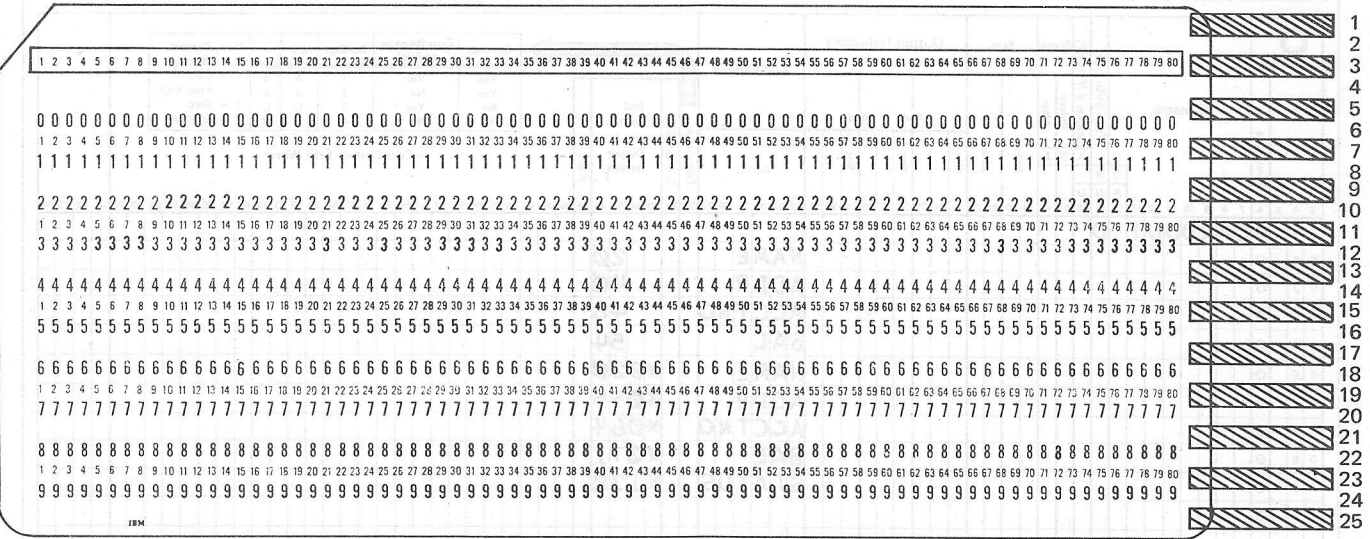

Figure 4-2. Printing Lines on an 80-Column Punch Card

For each field or constant you wish printed by the MFCU, you must make the following specifications on the Output Specifications sheet:

1. If a field is to be printed, enter the field name in columns 32-37.
2. Enter \* in column 40 to indicate that the field is to be printed not punched.
3. Enter any end position from 001 to 128 in columns 41-43.
4. If a constant is to be printed, enter the constant in columns 45-70.

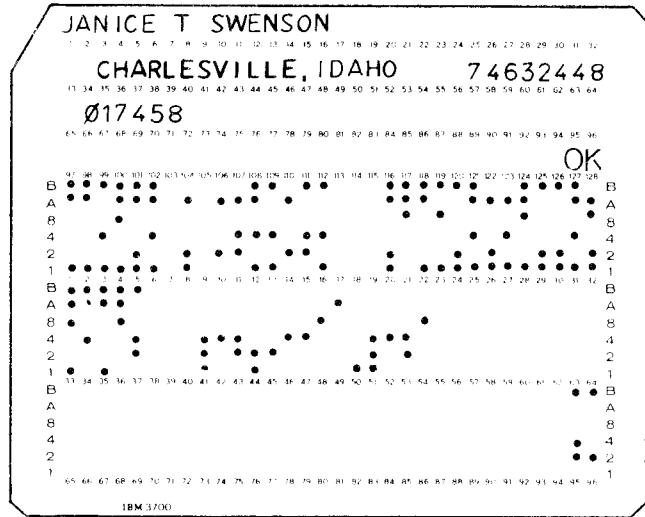

Figure 4-3. Formatted Printing on a 96-Column Card

For example, to print the fields on the card shown in Figure 4-3, the specifications in Figure 4-4 lines 06-10 are necessary. You indicate punching of these fields by specifying an end position without the asterisk (see Figure 4-4, lines 02-05). If you intend to punch fields and print fields, you need two specifications per field. If you have seven fields to be both punched and printed, you need 14 specifications.

Because printing and punching are two separate functions, it is possible to print a field without punching it and punch

a field without printing it. If you punch and print the same field, you may put each in different positions. In other words, you may format the punched fields in a different way than you format the printed fields.

IBM International Business Machine Corporation			RPG OUTPUT SPECIFICATIONS										IBM 3700					
Program		Date		Punching Instruction		Graphic Punch		Card Electro Number		Page 1 of 2		Program Identification		75 76 77 78 79 80				
Line	Form Type	File name	Type (H D T E)		Space		Skip		Output Indicators			Field Name		End Position in Output Record		Constant or Left Word		
			OR	AND	Before	After	NOT	And	And	Field Name	Commas	Zero Balances to Print	No Sign	CR	-	X	Remove Plus Sign	
01	O	CARDOUT	D															
02	O																	
03	O																	
04	O																	
05	O																	
06	O																	
07	O																	
08	O																	
09	O																	
10	O																	
11	O																	
12	O																	
13	O																	
14	O																	

Figure 4-4. Specifications for Punching and Printing on a Card (Formatted Printing – MFCU)

**Formatted Printing – MFCM**

Using formatted printing, you can print a field or constant on any six of the 25 print lines available on an 80-column card. For each field or constant you wish printed by the MFCM, you must make the following specifications on the Output-Format sheet:

1. When printing a field, enter the field name in columns 32-37.
2. Specify a print head number (1-6) in column 41.
3. Specify a print end-position (01-64) in columns 42 and 43. (The leading zero is required when specifying print positions 01-09.)
4. When printing a constant, enter the constant in columns 45-70.

For example, to print the fields shown in Figure 4-5, the specifications shown in Figure 4-6 are necessary. Coding lines 02 through 05 cause the fields to be punched. Coding lines 06 through 10 cause the fields and a constant, BALANCE, to be printed. As you can see, two specifications are required for each field that is to be both punched and printed. In order to obtain the desired printing results, the MFCM print heads must be aligned mechanically prior to running the program.

*Note:* The fourth line of printing also could have been printed using print head 4, with print heads 5 and 6 set to line positions lower on the card.

Because printing and punching are two separate functions, it is possible to print a field without punching it and to punch a field without printing it.

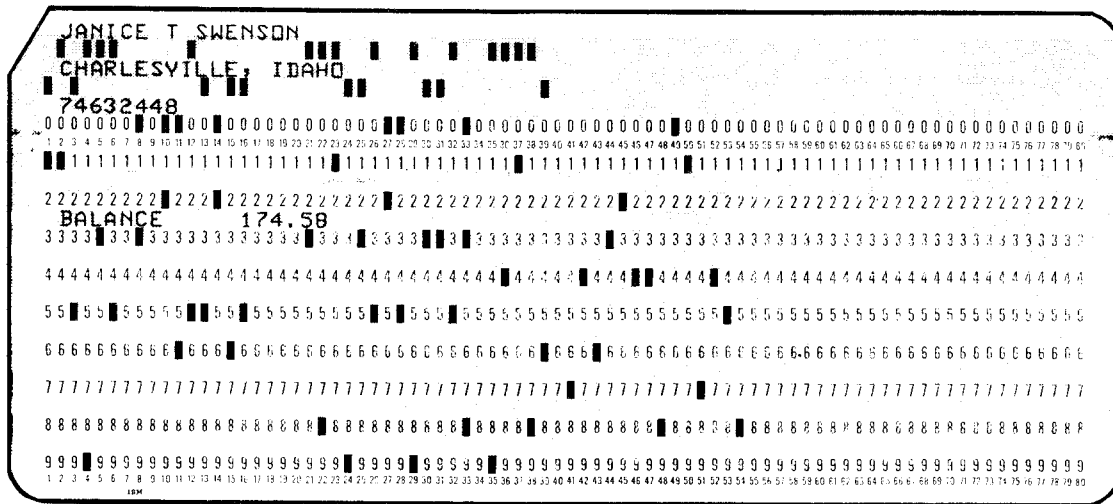

● Figure 4-5. Formatted Printing on an 80-Column Card



**RPG OUTPUT SPECIFICATIONS**

IBM International Business Machine Corporation

GX21-9090 U/M 050\*  
Printed in U.S.A.

Program		Punching Instruction	Graphic				Card Electro Number	Page 1 2 of		Program Identification 75 76 77 78 79 80				
Programmer			Punch											

Line	Form Type	Filename	Type (H/D/E)				Space	Skip	Output Indicators				Field Name	Edit Codes B/A/C/T/S/R	End Position in Output Record	P/B/L/R	Constant or Edit Word
			O	R	A	D			Before	Alter	Not	Not					
01	O	CARDOUT	D														
02	O																
03	O																
04	O																
05	O																
06	O																
07	O																
08	O																
09	O																
10	O																'BALANCE'
11	O																

● Figure 4-6. Specifications for Punching and Printing on a Card (Formatted Printing – MFCM)

**Unformatted Printing (\*PRINT) – MFCU and MFCM**

Using formatted printing, recall that if you wish to both punch and print a field, you must have two entries per field on the Output-Format sheet: a punch entry and a print entry. If you want several fields to be both punched and printed, there is a great deal of coding involved.

RPG II has a special reserved word, \*PRINT, which allows you to punch and print fields and constants with less coding. When \*PRINT is specified, it causes all previous fields described for the record to be printed. Use of \*PRINT is known as unformatted printing.

Figure 4-7 shows the use of the \*PRINT specification. NAME, ADDR, ACCTNO, and BAL are to be punched. Following these field names in columns 32-37 is the entry \*PRINT. This entry causes the previous four fields to also be printed on the card (see Figures 4-8 and 4-9).

Using \*PRINT with the MFCU causes fields and constants to be printed in positions corresponding to the punch positions. For example, ACCTNO is punched in positions 41-48 and also is printed in positions 41-48.

On the MFCM, there is not space to print 80 characters on one line. Therefore, data punched in columns 1-64 is printed in print positions 1-64 by print head 1; data punched in columns 65-80 is printed in positions 49-64 by print head 2 (Figure 4-9).

The word \*PRINT can be used only once for a record and must be entered after the description of all fields that are to be both punched and printed. Suppose, instead of printing all four fields (NAME, ADDR, ACCTNO, and BAL), you want to print only NAME and ACCTNO. In this case, the entry \*PRINT must follow NAME and ACCTNO. ADDR and BAL must be described after the \*PRINT entry (Figure 4-10).

Columns 7-22 and 39-74 must always be left blank on the \*PRINT specification line.

RPG OUTPUT SPECIFICATIONS	
Punching Instruction	Graphic
	Card Electro Number

Output Indicators		Field Name	End Position in Output Record	Commas	Zero Balances to Print
Other	And				
21	22 23 24 25 26 27 28 29 30 31	*AUTO	38	Yes Yes No	Yes Yes No
		NAME	19		
		ADDR	40		
		ACCTNO	48		
		BAL	54		
		*PRINT			

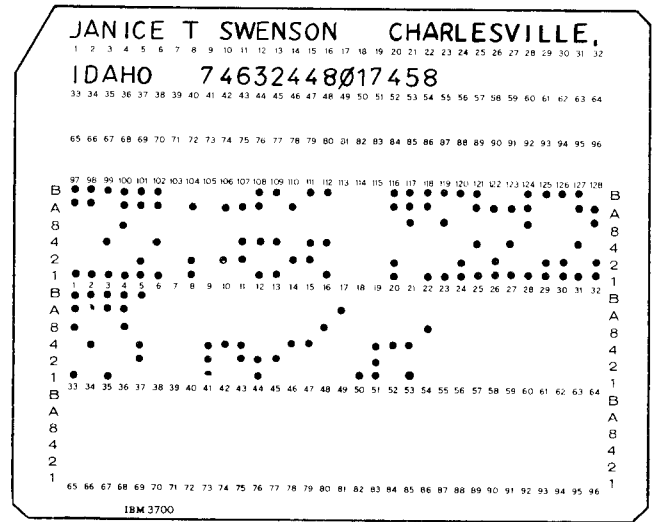

Figure 4-8. Unformatted Printing on a 96-Column Card

Figure 4-7. Punching and Printing on a Card Using \*PRINT (Unformatted Printing)

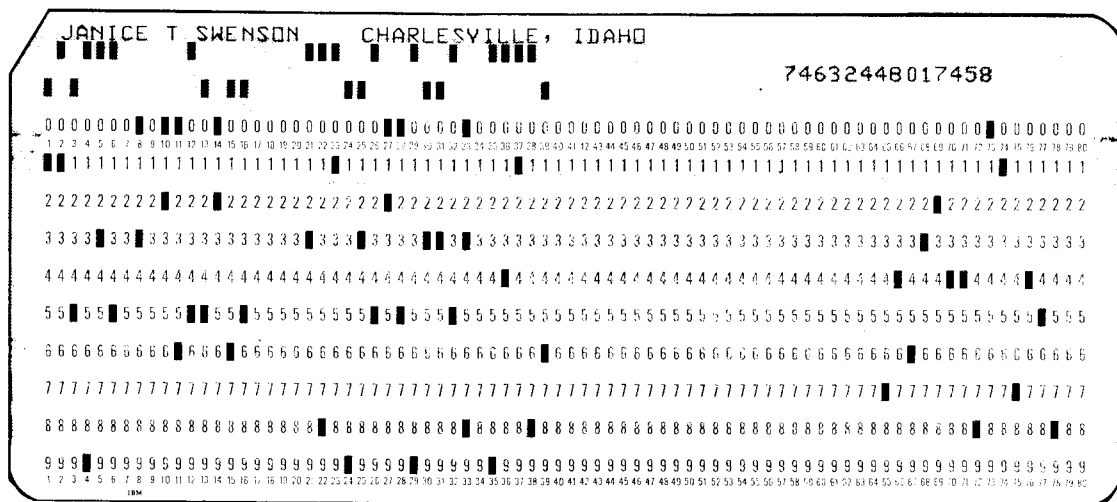

Figure 4-9. Unformatted Printing on an 80-Column Card

RPG OUTPUT SPECIFICATIONS		
Punching Instruction	Graphic Punch	Card Electro Number
Output Indicators		Field Name
And	And	
Not	Not	Not
22	23	24
26	27	28
29	30	31
32	33	34
35	36	37
38	39	40
41	42	43
44	45	46
47	48	49
50	51	52
53	54	55
56		
*AUTO		NAME
		ACCTNO
		*PRINT
		ADDR
		BAL
		20
		48
		40
		54

RPG OUTPUT SPECIFICATIONS		
Punching Instruction	Graphic Punch	Card Electro Number
Output Indicators		Field Name
And	And	
Not	Not	Not
21	22	23
24	25	26
27	28	29
30	31	32
33	34	35
36	37	38
39	40	41
42	43	44
45	46	47
48	49	50
51	52	53
54	55	56
*AUTO		NAME
		ADDR
		TELE
		*PRINT
		20
		50
		60
10	21	

Figure 4-10. Using \*PRINT to Specify Fields When Some are Punched Only

Figure 4-11. Conditioning \*PRINT Entry

You may use any indicator in columns 23-31 to condition the \*PRINT entry. That specification will then be performed only when the condition set by the indicator is met. For example, according to the specification in Figure 4-11, line 05, the fields will be printed only when 10 and 21 are both on at the same time.

#### Editing A Field Printed on the Card

Any field that is to be printed, using either formatted or unformatted printing, can be edited. This, of course, will make the printed field easier to read and understand.

Editing a field to be printed on the card is done in the same way as editing a field to be printed on the printer. However, editing should be kept at a minimum so that the length of the printed field won't be considerably larger than the length of the punched field. Zero suppression or merely removal of the sign are often done since they do make the printing easier to read, but still keep the printing in a one-to-one relationship with the punches.

#### USING ONE FILE FOR BOTH INPUT AND OUTPUT

In your experience with RPG II, you have used card files as input files and output files. Suppose, however, you wanted to punch into the same card that was read into the computer. Is it possible to use input and output files to do this? No, input cards are only read and output cards are only punched or printed. What you need is a combination of the two. The RPG II language allows such a file combination. This type of file is called a *combined file*.

*Note:* In this discussion, only the MFCU is used for reference; unless noted otherwise, the MFCM can be used in the same way.

#### Punching Into the Same Card that is Read

A company keeps a daily record of the amount of each item sold. At the end of the week the daily amount sold for each item is punched into the card in six different fields, one field per day. These cards are then used in a program which totals the daily amount sold for each item and punches that total into the same card that contained the daily amounts.

Figure 4-12 shows the format of the data card which is read. Each card contains the end of the week date (DATE), the item number (ITEMNO) and daily amounts sold (FLD1 through FLD6). Figure 4-13 shows the same card after it has been punched. TOTAL is the field punched after the total amount sold has been calculated.

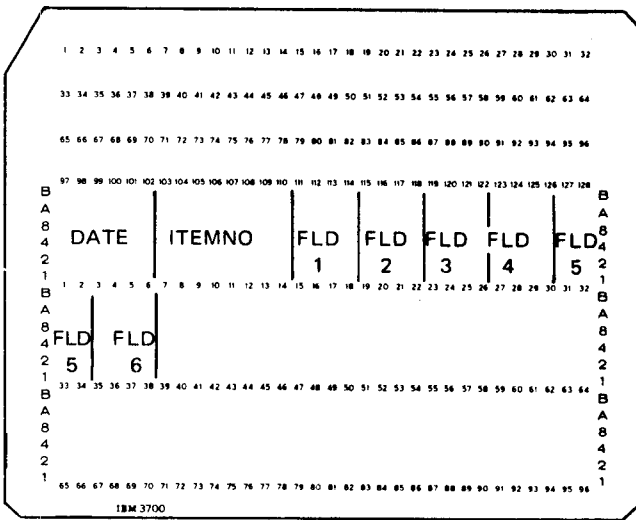

Figure 4-12. Combined File Card Read

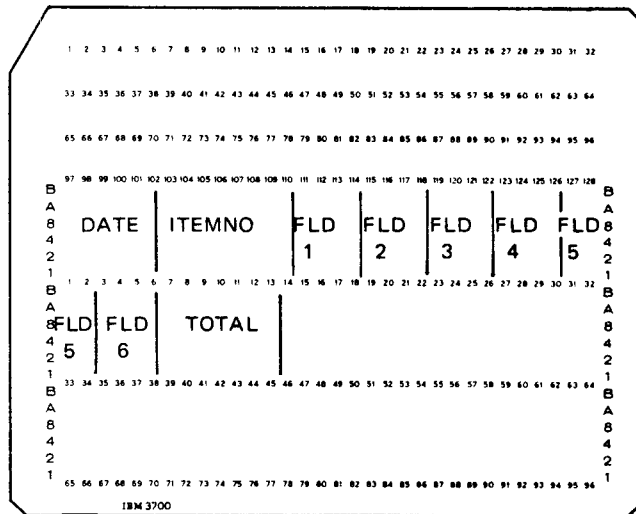

Figure 4-13. Combined File Card After Punching



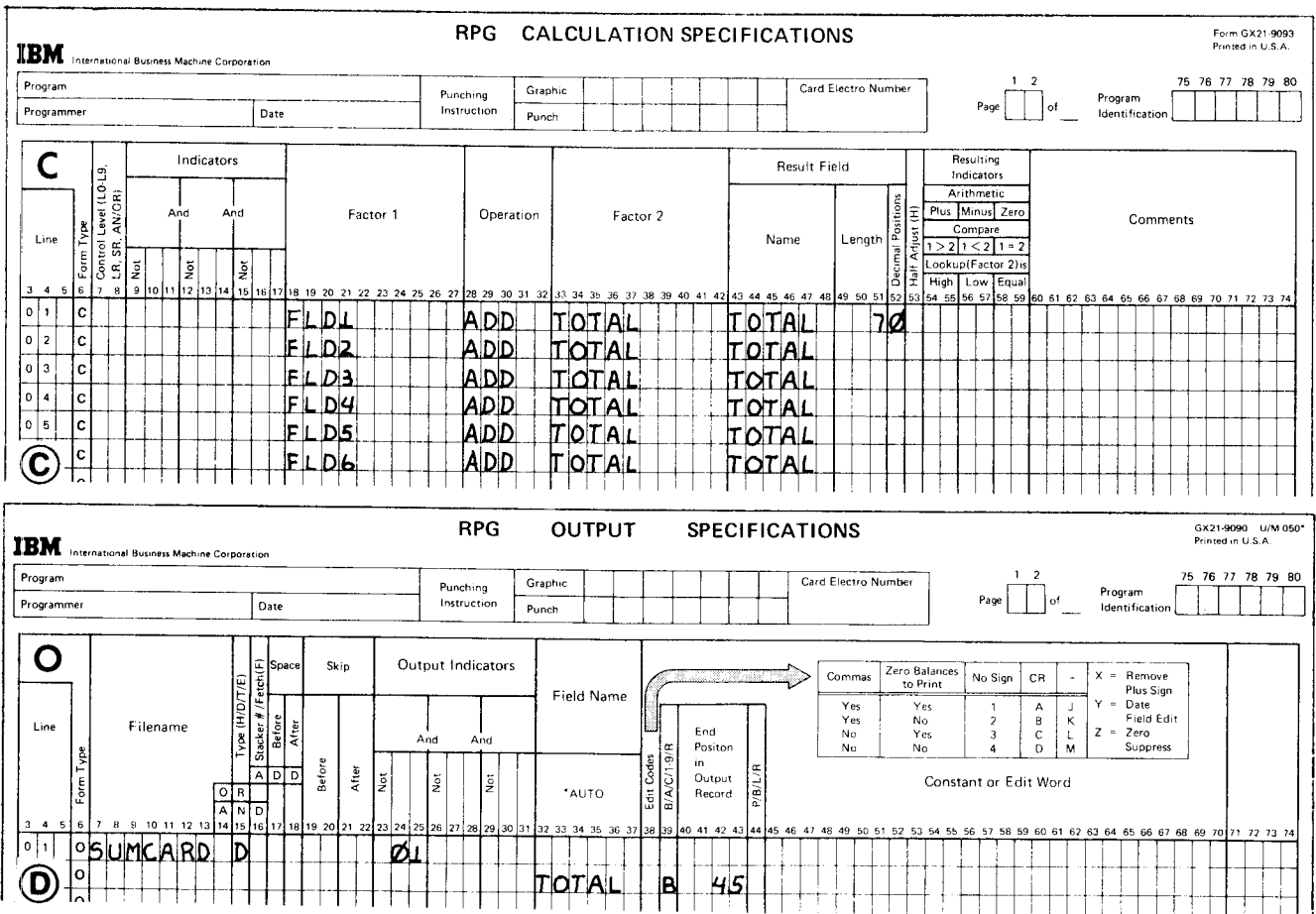

Figure 4-14 (Part 2 of 2). Specifications for Reading and Punching Each Card

**Punching into a Blank Card in the File**

You have just learned how to use a combined file when you wish to read and punch the same card. What if you wish to read several cards and then punch another card in the same file? Remember any time you want to read and punch cards from the *same* file, that file must be defined as a combined file.

Assume that a company which keeps a weekly record of items sold, uses these records at the end of the month to determine the quantity of items on hand. For each item, four different types of cards are read (Figure 4-15).

1. Onhand, which contains the number in stock at the beginning of the month.
2. Issues, which contains the number sold during the month. There is one of these cards for each week.
3. Receipts, which contains the number added to stock through reorder.
4. New Onhand, which is blank. After calculations have been performed to determine the number on hand, this number and the date and a code are punched into the card. This card, when punched, will be used as next month's Onhand card, and will be in the same format as the current Onhand card.

Each of these card types is identified by a code in column 96 (see Figure 4-15). (This code would be column 80 if the MFCM were used.)

1	2	3	4	5	6	7	8	9	10	11	12	13	14	15	16	17	18	19	20	21	22	23	24	25	26	27	28	29	30	31	32
33	34	35	36	37	38	39	40	41	42	43	44	45	46	47	48	49	50	51	52	53	54	55	56	57	58	59	60	61	62	63	64
65	66	67	68	69	70	71	72	73	74	75	76	77	78	79	80	81	82	83	84	85	86	87	88	89	90	91	92	93	94	95	96

97	98	99	100	101	102	103	104	105	106	107	108	109	110	111	112	113	114	115	116	117	118	119	120	121	122	123	124	125	126	127	128	B A 8 4 2 1 B A 8 4 2 1 B A 8 4 2 1 1
ITEMNO											DATE					INSTOK												B A 8 4 2 1				
1	2	3	4	5	6	7	8	9	10	11	12	13	14	15	16	17	18	19	20	21	22	23	24	25	26	27	28	29	30	31	32	B A 8 4 2 1

33	34	35	36	37	38	39	40	41	42	43	44	45	46	47	48	49	50	51	52	53	54	55	56	57	58	59	60	61	62	63	64	B A 8 4 2 1
																												B A 8 4 2 1				
65	66	67	68	69	70	71	72	73	74	75	76	77	78	79	80	81	82	83	84	85	86	87	88	89	90	91	92	93	94	95	96	B A 8 4 2 1 1

IBM 3700

Onhand Card

1	2	3	4	5	6	7	8	9	10	11	12	13	14	15	16	17	18	19	20	21	22	23	24	25	26	27	28	29	30	31	32
33	34	35	36	37	38	39	40	41	42	43	44	45	46	47	48	49	50	51	52	53	54	55	56	57	58	59	60	61	62	63	64
65	66	67	68	69	70	71	72	73	74	75	76	77	78	79	80	81	82	83	84	85	86	87	88	89	90	91	92	93	94	95	96

97	98	99	100	101	102	103	104	105	106	107	108	109	110	111	112	113	114	115	116	117	118	119	120	121	122	123	124	125	126	127	128	B A 8 4 2 1 B A 8 4 2 1 B A 8 4 2 1 1
ITEMNO											DATE					RECPT												B A 8 4 2 1				
1	2	3	4	5	6	7	8	9	10	11	12	13	14	15	16	17	18	19	20	21	22	23	24	25	26	27	28	29	30	31	32	B A 8 4 2 1

33	34	35	36	37	38	39	40	41	42	43	44	45	46	47	48	49	50	51	52	53	54	55	56	57	58	59	60	61	62	63	64	B A 8 4 2 1
																												B A 8 4 2 1				
65	66	67	68	69	70	71	72	73	74	75	76	77	78	79	80	81	82	83	84	85	86	87	88	89	90	91	92	93	94	95	96	B A 8 4 2 1 1

IBM 3700

Receipt Card

1	2	3	4	5	6	7	8	9	10	11	12	13	14	15	16	17	18	19	20	21	22	23	24	25	26	27	28	29	30	31	32
33	34	35	36	37	38	39	40	41	42	43	44	45	46	47	48	49	50	51	52	53	54	55	56	57	58	59	60	61	62	63	64
65	66	67	68	69	70	71	72	73	74	75	76	77	78	79	80	81	82	83	84	85	86	87	88	89	90	91	92	93	94	95	96

97	98	99	100	101	102	103	104	105	106	107	108	109	110	111	112	113	114	115	116	117	118	119	120	121	122	123	124	125	126	127	128	B A 8 4 2 1 B A 8 4 2 1 B A 8 4 2 1 1
ITEMNO											DATE					ISSUES												B A 8 4 2 1				
1	2	3	4	5	6	7	8	9	10	11	12	13	14	15	16	17	18	19	20	21	22	23	24	25	26	27	28	29	30	31	32	B A 8 4 2 1

33	34	35	36	37	38	39	40	41	42	43	44	45	46	47	48	49	50	51	52	53	54	55	56	57	58	59	60	61	62	63	64	B A 8 4 2 1
																												B A 8 4 2 1				
65	66	67	68	69	70	71	72	73	74	75	76	77	78	79	80	81	82	83	84	85	86	87	88	89	90	91	92	93	94	95	96	B A 8 4 2 1 1

IBM 3700

Issues Card

1	2	3	4	5	6	7	8	9	10	11	12	13	14	15	16	17	18	19	20	21	22	23	24	25	26	27	28	29	30	31	32
33	34	35	36	37	38	39	40	41	42	43	44	45	46	47	48	49	50	51	52	53	54	55	56	57	58	59	60	61	62	63	64
65	66	67	68	69	70	71	72	73	74	75	76	77	78	79	80	81	82	83	84	85	86	87	88	89	90	91	92	93	94	95	96

97	98	99	100	101	102	103	104	105	106	107	108	109	110	111	112	113	114	115	116	117	118	119	120	121	122	123	124	125	126	127	128	B A 8 4 2 1 B A 8 4 2 1 B A 8 4 2 1 1
																												B A 8 4 2 1				
1	2	3	4	5	6	7	8	9	10	11	12	13	14	15	16	17	18	19	20	21	22	23	24	25	26	27	28	29	30	31	32	B A 8 4 2 1

33	34	35	36	37	38	39	40	41	42	43	44	45	46	47	48	49	50	51	52	53	54	55	56	57	58	59	60	61	62	63	64	B A 8 4 2 1
																												B A 8 4 2 1				
65	66	67	68	69	70	71	72	73	74	75	76	77	78	79	80	81	82	83	84	85	86	87	88	89	90	91	92	93	94	95	96	B A 8 4 2 1 1

IBM 3700

New Onhand Card

Figure 4-15. Four Card Types





RPG CALCULATION SPECIFICATIONS																														Form GX21-9093 Printed in U.S.A.	
Program _____					Punching Instruction _____					Graphic _____					Card Electro Number _____					Page <u>1</u> of <u>2</u>		Program Identification <u>75 76 77 78 79 80</u>									
C	Line	Form Type	Control Level (LD, LB, LR, SR, ANIOR)	Indicators	Factor 1	Operation	Factor 2	Name	Length	Result Field	Resulting Indicators	Comments																			
				And And							Arithmetic																				
				Not Not Not Not							Plus Minus Zero																				
											Compare																				
											1 > 2   1 < 2   1 = 2																				
											Lookup (Factor 2) is																				
											High Low Equal																				
											Decimal Positions																				
											Half Adjust (H)																				
C	02				INSTOK	SUB	ISSUES	INSTOK																							
C	03				RECPT	ADD	INSTOK	INSTOK																							

RPG OUTPUT SPECIFICATIONS																														Form GX21-9090 U/M 050 Printed in U.S.A.							
Program _____					Punching Instruction _____					Graphic _____					Card Electro Number _____					Page <u>1</u> of <u>2</u>		Program Identification <u>75 76 77 78 79 80</u>															
O	Line	Form Type	Filename	Type (H/D/E)	Stacker # (F)	Space	Skip	Output Indicators	Field Name	Edit Codes	End Position in Output Record	Constant or Edit Word																									
				O R	A	D	D	Before After	And And	B/C/D/T/S/R	P/B/L/R	Commas	Zero Balances to Print	No Sign	CR	-	X = Remove Plus Sign	Y = Date	Z = Zero	M = Suppress																	
				Before After	Not Not Not							Yes	Yes	1	A	J																					
												No	No	2	B	K																					
												No	Yes	3	C	L																					
												No	No	4	D	M																					
D	01	O	MONTHRHP	D3				04																													
	02	O							ITEMNO		8																										
	03	O							UDATE		14																										
	04	O							INSTOK		23																										
											96	'0'																									

For the MFCM, change 96 to 80.

Figure 4-16 (Part 2 of 2). Specifications for Reading and Punching Combined File Cards

On the Output-Format sheet (Figure 4-16, insert D) you must show the fields which are to be punched. Since only the blank card is punched, punching occurs only when 04 is on. Because the card punched will be used as next month's Onhand card, ITEMNO, DATE, INSTOCK and a code must be punched.

#### When To Specify a Combined File

How do you know whether to describe a card file that must be read into the computer as an input or as a combined file? If you remember these basic rules you will have no trouble deciding.

1. If the file contains cards that are to be *both* read and punched, it must be a combined file.
2. If cards in the file are to be stacker selected on some basis other than card type, the file must be described as a combined file (see *Stacker Selection, Selecting on a Basis Other Than Card Type*).

#### STACKER SELECTION

Stacker selection is the means by which you can separate certain cards from all others in the file. If stacker selection entries are not made, all cards automatically fall into specific, predefined stackers:

- MFCU1: Stacker 1
- MFCU2: Stacker 4
- MFCM1: Stacker 1
- MFCM2: Stacker 4 (Model A2) or Stacker 5 (Model A1)

*Note:* Unless stated otherwise, this discussion applies to both the MFCU and the MFCM.

## Input and Combined File Cards

Input file cards are stacker selected by input specifications. Combined file cards can be stacker selected by either input or output specifications.

### *Selecting on the Basis of Card Type*

Stacker selection by input specifications must be on the basis of card type. This means you may separate all cards of one type from the input file by specifying a special stacker into which they should be stacked.

Suppose you want to create a monthly list of all items in a retail store. Three card types are used: one for new items, one for discontinued items, and one for all other items. The manager wants to take all cards describing discontinued items out of his file. He can do this by specifying the stacker into which the card type is to be selected. The specification in Figure 4-17, insert A, line 02, will separate the discontinued item cards (card identified with a D in the last column) from the other cards by putting them in stacker 2.

Notice that the OR relationship was used in describing the three card types. When stacker selection is done with the OR relationship one rule must be kept in mind: each card type will fall into the stacker indicated for it. For example, Figure 4-17, insert A, shows the stacker selection entry 2 for the second card type. The other card types have no stacker selection entry. They are, therefore, stacked in stacker 1 if they were entered in the primary hopper or in stacker 4 or 5 if entered in the secondary hopper. According to Figure 4-17, insert B, card type 02 falls into stacker 2, card type 03 falls into stacker 3. Where does card type 01 fall? It will fall into either stacker 1, 4, or 5 depending upon the device used and the hopper in which the file was entered.

### *Selecting on a Basis Other Than Card Type*

Suppose you wish to stacker select input file cards on some basis other than card type, such as the result of calculations, the results of matching records, or the contents of an input field. For example, assume that the cards which contain information concerning new, discontinued, and available items in the store also contain the amount on hand at the end of the month. In addition to listing all items, records of items which need to be reordered are selected to a separate stacker. The critical reorder point occurs when there are 25 items or less left on hand. (This, of course, does not apply to discontinued items.) Thus, in the calculations, ONHAND is always compared to 25. If the amount is equal or less than 25, the item needs to be reordered. All cards describing items to be reordered are to be separated from the others in the file by stacking them in a special stacker.

Where would you specify the stacker select entry that would do this? There are only two possibilities — Input sheet or Output-Format sheet. Remember that input cards can be stacker selected on the Input sheet on the basis of card type only. In our example, not all cards of any one type will describe items that need to be reordered. Therefore, the selection is not on the basis of card type and cannot be specified for an input card on the Input sheet. This leaves only the Output-Format sheet on which to specify this stacker selection. But since our file is not an output file, how could it be specified on the Output-Format sheet? Remember that a combined file serves for both input and output. Therefore, a file from which cards are to be stacker selected must be defined as a *combined file*.

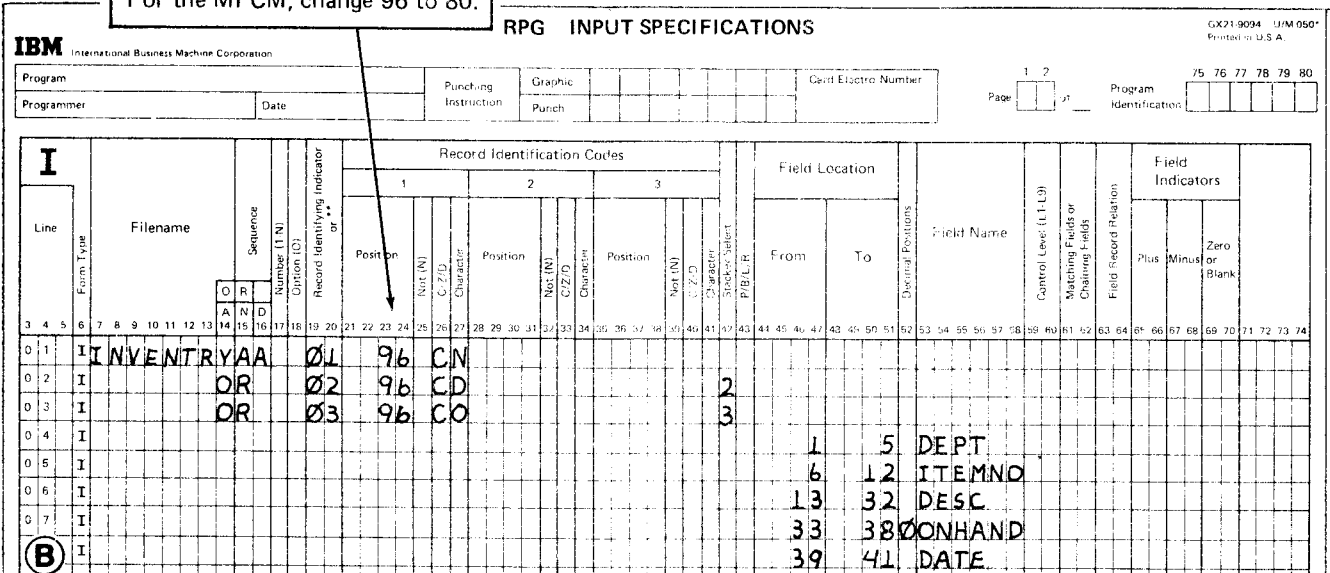
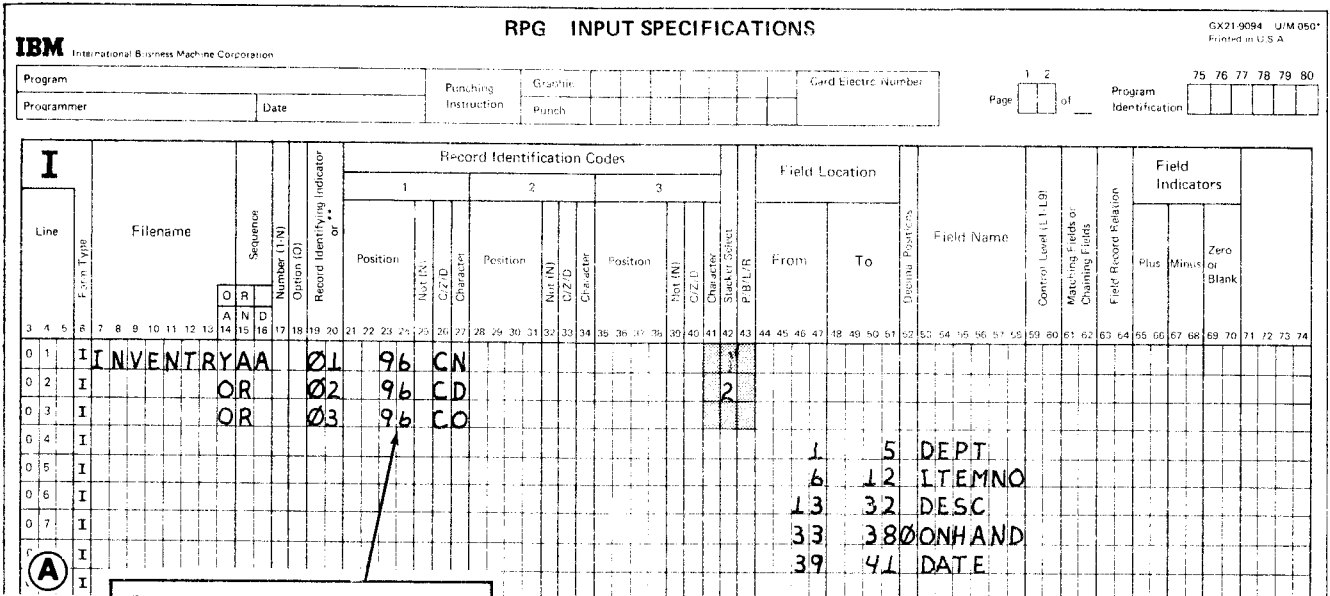

**Figure 4-17. Stacker Selecting Cards in an OR Relationship**

Figure 4-18 shows the entries which are necessary to stacker select all cards (except discontinued) cards) which contain 25 or less in the ONHAND field. The file would be described as a combined file by placing a C in column 15 of the File Description sheet.

Figure 4-18, insert A, shows that the ONHAND field is compared with 25. If the compare is equal or less, indicator 10 turns on to indicate that the item should be ordered. Indicator 10 is then used on the Output-Format sheet to condition the stacker selection entry (Figure 4-18, insert B, line 01). When 10 is on (there are 25 or less of the item left) and the card is not a discontinued item (indicator 02 is not on), the card is selected into stacker 2. All other cards go into stacker 1.

**Rules for Stacker Selecting Cards from a Combined File**

Combined file cards can be stacker selected by both input and output-format specifications. Input stacker selection is based on card type alone; output stacker selection can be on any other basis. In fact, you can stacker select some

card types by input specifications and others by output-format specifications. However, one card type should not have both types of stacker selection specifications. If it does, the input entry is ignored. Furthermore, if you are punching or printing on combined file cards that are also to be stacker selected, the stacker selection entry *must* be on the Output-Format sheet.

**Stacker Selecting Output File Cards**

Output file cards are stacker selected by output specifications. For example, stacker selection by output specifications can be made on the basis of results of calculations, matching records, content of fields, and error conditions. Output stacker selection can be based on card type, but card type selection is usually done with input specifications.

Consider an end-of-the-month inventory program that: (1) finds the balance on hand for each item, (2) determines if and when an item should be reordered; and (3) finds any items that are overstocked.

**IBM** International Business Machine Corporation Form GX21 9093  
Printed in U.S.A.

**RPG CALCULATION SPECIFICATIONS**

Program		Punching Instruction	Graphic Punch	Card Electro Number	Page 1 2 of	Program Identification 75 76 77 78 79 80
Programmer		Date				

Line	Form Type	Control Level (LO, U)	Indicators			Factor 1	Operation	Factor 2	Result Field		Resulting Indicators	Comments
			And	And	And				Name	Length		
01	C					ONHAND	COMP	25			1010	

**IBM** International Business Machine Corporation Form GX21 9090 UJM 0507  
Printed in U.S.A.

**RPG OUTPUT SPECIFICATIONS**

Program		Punching Instruction	Graphic Punch	Card Electro Number	Page 1 2 of	Program Identification 75 76 77 78 79 80
Programmer		Date				

Line	Form Type	Filename	Type (H/D/T/E)	Stacker #	Before	After	Output Indicators			Field Name	Constant or Edit Word
							And	And	And		
01	O	SELECT	D2							AUTO	

Figure 4-18. Stacker Selection on the Basis of Calculations

Two files are used: an input file and an output file. The input file contains three types of cards (Figure 4-19):

1. Inventory Balance cards, which contain the number in stock at the beginning of the month, and the maximum and minimum quantities which should be kept in stock.
2. Issue summary cards, which contain the total number issued during each week. Since this is an end of the month job, there may be several of these.
3. Receipt cards, which contain the number added to stock through reorder.

Each item must have a balance card. The other two cards are optional. The output file contains blank cards.

For each item, the total number in stock will be calculated from information on the input cards and then punched into a blank output file card along with all other fields found on the balance card. The format of the output card must be the same as the input balance card, since this output card is used as the balance card for next month's inventory.

Before the balance on hand is punched into the blank cards, the amount is compared to the maximum and minimum quantities in stock established for each item to determine reorder procedure. As a result of the comparison, four conditions could occur:

1. If the amount in stock is zero or back-ordered, the item should be reordered immediately.
2. If the amount is greater than zero but equal to or below the minimum, normal reordering procedures should be followed.
3. If the amount is between maximum and minimum, the item does not need to be reordered.
4. If the quantity is greater than the maximum, the manager should be notified of the overstocked item.

Instead of putting all newly punched balance cards into one stacker, it would be more convenient, when preparing to reorder, if they were stacked into different stackers: one stacker for items requiring immediate attention (reorder immediately or greatly overstocked), one for items to be reordered normally, and one for items which need not be reordered. To separate them, you specify different stackers they could go into on the basis of the amount in the INSTOK field.

Inventory Balance Card format: A card with 128 columns. Fields are: ITEMNO (columns 1-10), DATE (columns 11-15), INSTOK (columns 16-20), MAX (columns 21-30), and MIN (columns 31-40). The card is punched with 'B A 8 4 2 1' on the left and 'B A 8 4 2 1' on the right, with 'CODE-A' printed vertically on the right side. The IBM 3700 logo is at the bottom.

Inventory Balance Card

Issue Summary Card format: A card with 128 columns. Fields are: ITEMNO (columns 1-10), DATE (columns 11-15), and ISSUES (columns 16-20). The card is punched with 'B A 8 4 2 1' on the left and 'B A 8 4 2 1' on the right, with 'CODE-I' printed vertically on the right side. The IBM 3700 logo is at the bottom.

Issue Summary Card

Receipt Card format: A card with 128 columns. Fields are: ITEMNO (columns 1-10), DATE (columns 11-15), and RECPT (columns 16-20). The card is punched with 'B A 8 4 2 1' on the left and 'B A 8 4 2 1' on the right, with 'CODE-R' printed vertically on the right side. The IBM 3700 logo is at the bottom.

Receipt Card

Figure 4-19. Cards Used for Inventory Job

From which file do cards come that are to be stacker selected? They come from the output file since they are the newly created balance cards. Therefore stacker selection entries must be made on the Output-Format sheet. Stacker selection entries are on the basis of the compare operation. Thus these compare operations must set indicators which will be used on the Output-Format sheet to indicate into which stacker cards must fall. Figure 4-20 shows the program specifications.

Figure 4-20, insert A, lines 01, 02, shows operations used for finding the number in stock. When a control break occurs (a card for a new item is read) the number in stock is compared as many as three times (lines 04-06) to determine into which stacker the cards should fall for reordering purposes. Resulting indicators are set off (line 03), since improper selection could otherwise occur due to multiple indicators set for a single condition.

INSTOK is first compared to zero. If it is equal or below, indicator 10 is turned on. If INSTOK is greater than zero, it is compared to the minimum quantity. When INSTOK is equal to or less than minimum, indicator 20 is turned on. If INSTOK is greater than minimum, it is then compared to maximum. Indicator 10 is turned on if INSTOK is greater than maximum; indicator 30 is turned on if it is equal or less.

Any of these indicators can be set: 10, 20, 30. Since they indicate the amount in the field INSTOK, they also indicate into which stacker cards should fall. (See Figure 4-20, insert B.) If 10 is on (INSTOK is zero or less or greater than maximum) cards go into stacker 4. If 20 is on (INSTOK is greater than zero, but equal to or less than the minimum), cards go into stacker 2. If 30 is on (INSTOK is greater than MIN but less than or equal to MAX) cards go into stacker 3. In all cases, five fields and a constant are punched on each blank card before it is stacked.

#### *Rules for Stacker Selecting Cards From An Output File*

If no stacker selection entry is made for the output file, cards automatically fall into predefined stackers – stacker 1 if the file is in the primary hopper; stacker 4 if the file is in the secondary hopper. You may, however, cause cards to be stacked in any of the four (or five) available stackers merely by entering 1, 2, 3, 4 or 5 (5 for MFCM Model A1) in column 16 of the Output-Format sheet.

*All* cards from the same file will fall into the specified stacker unless indicators are used in columns 23-31. If, as in this example, you want cards to fall into different stackers, you *must* use indicators set by calculation operations to condition the stacker selection specifications.

#### **Merging Input and Output File Cards**

Putting cards from two different files into the same stacker is known as merging cards. Any two files can be merged. To do so, you merely specify the same stacker for each file.

When input and output file cards are merged, the output file card for *each* program cycle is stacked in front of the input file card read at the beginning of the cycle. Why are output cards stacked before input file cards? According to the way the MFCU and MFCM operate:

1. An input card is not stacked until the next input card is read.
2. Any output card that is punched is stacked immediately.

These statements are the key to the order of merging. Consider what this means during a regular program cycle. When an output file card is punched, it is stacked. This could be either at total time or detail time. However, the input card read at the beginning of the cycle is not stacked until the next card is read. This results in the output card being stacked in front of the input card. Most often, however, you would want the merged cards ordered so that input cards precede output cards.

Reversal of the normal stacking order can be accomplished by specifying look ahead fields or dual input areas for the input file. When either of these is specified, input cards are stacked before output cards.

Stacker selection cannot be specified for input files with dual input areas. Therefore, if you wish to merge cards from the input and output file, you must merge the cards into the default stacker for the input file (defined previously – see *Stacker Selection*).

**IBM** International Business Machine Corporation **RPG CALCULATION SPECIFICATIONS** Form GX21-9083 Printed in U.S.A.

Program \_\_\_\_\_ Date \_\_\_\_\_ Punching Instruction \_\_\_\_\_ Graphic \_\_\_\_\_ Card Electro Number \_\_\_\_\_

Programmer \_\_\_\_\_ Date \_\_\_\_\_ Punch \_\_\_\_\_ Page 1 of 2 Program Identification 75 76 77 78 79 80

Line	Form Type	Indicators					Factor 1	Operation	Factor 2	Result Field		Resulting Indicators			Comments
		And	And	Not	Not	Not				Name	Length	Arithmetic	Plus	Minus	
01	C	02					INSTOK	SUB	ISSUES	INSTOK					
02	C	03					RECPT	ADD	INSTOK	INSTOK					
03	C	LL						SETOF							
04	C	LL					INSTOK	COMP	0					102030	
05	C	LLN10					INSTOK	COMP	MIN					1010	
06	C	LLN10N20					INSTOK	COMP	MAX					2020	
07	C													103030	

**IBM** International Business Machine Corporation **RPG OUTPUT SPECIFICATIONS** GX21-9090 UJM 0500 Printed in U.S.A.

Program \_\_\_\_\_ Date \_\_\_\_\_ Punching Instruction \_\_\_\_\_ Graphic \_\_\_\_\_ Card Electro Number \_\_\_\_\_

Programmer \_\_\_\_\_ Date \_\_\_\_\_ Punch \_\_\_\_\_ Page 1 of 2 Program Identification 75 76 77 78 79 80

Line	Form Type	Filename	Space			Skip			Output Indicators			Field Name	End Position in Output Record	PIB/LR	Constant or Edit Word
			Before	After	At	Before	After	Not	Not	Not					
01	O	PUNCH										*AUTO			
02	O												8		
03	O												14		
04	O												23		
05	O												32		
06	O												41		
07	O												9b	'A'	
08	O														
09	O														

For MFCM, change 96 to 80.

Figure 4-20. End-of-Month Inventory Job

**Punching and Printing on Cards**

1. Why is it important to print on a card the same information punched in a card?
2. Using the following information, write the output-format specifications to punch and print the following fields on output cards:

<i>Field</i>	<i>End Position</i>
CUSTNO	5
NAME	26
AMT	32
INVNO	38
DATE	44
2 (constant)	96 (use 64 for MFCM)

The information should be printed in the same relative positions as it was punched. Do not use \*PRINT for this. For the MFCM (Model 15 only), use print head 1 for all fields.

3. Do problem 2 using \*PRINT.

**Using One File For Both Input and Output**

4. When should a file be specified as combined?
5. If all master cards in a file are to be separated from item cards in the same file, the file type should be specified as\_\_\_\_\_.
6. True or False? Both printer files and card files can be combined files.
7. An electric company wishes to find the amount each customer owes for the electricity he used during the past month. The input file consists of three types of records for each customer:
  - READ1 which contains the meter reading at the beginning of the month.
  - READ2 which contains the meter reading at the end of the month. This card will be used as next month's READ1 card. It now contains a blank in the last column, and must therefore be punched with a 1 in the last column.
  - AMOUNT DUE which contains a blank field (AMTDUE) which will be punched with the amount each customer owes.

For each account these three cards must be present and in the order indicated.



1	2	3	4	5	6	7	8	9	10	11	12	13	14	15	16	17	18	19	20	21	22	23	24	25	26	27	28	29	30	31	32						
33	34	35	36	37	38	39	40	41	42	43	44	45	46	47	48	49	50	51	52	53	54	55	56	57	58	59	60	61	62	63	64						
65	66	67	68	69	70	71	72	73	74	75	76	77	78	79	80	81	82	83	84	85	86	87	88	89	90	91	92	93	94	95	96						
97	98	99	100	101	102	103	104	105	106	107	108	109	110	111	112	113	114	115	116	117	118	119	120	121	122	123	124	125	126	127	128						
B	A	8	4	2	1	NAME										ADDR										B	A	8	4	2	1						
B	A	8	4	2	1	1	2	3	4	5	6	7	8	9	10	11	12	13	14	15	16	17	18	19	20	21	22	23	24	25	26	27	28	29	30	31	32
B	A	8	4	2	1	READ1																				B	A	8	4	2	1						
B	A	8	4	2	1	33	34	35	36	37	38	39	40	41	42	43	44	45	46	47	48	49	50	51	52	53	54	55	56	57	58	59	60	61	62	63	64
B	A	8	4	2	1	65	66	67	68	69	70	71	72	73	74	75	76	77	78	79	80	81	82	83	84	85	86	87	88	89	90	91	92	93	94	95	96
B	A	8	4	2	1																					CODE 1	B	A	8	4	2	1					

READ1 Card

1	2	3	4	5	6	7	8	9	10	11	12	13	14	15	16	17	18	19	20	21	22	23	24	25	26	27	28	29	30	31	32						
33	34	35	36	37	38	39	40	41	42	43	44	45	46	47	48	49	50	51	52	53	54	55	56	57	58	59	60	61	62	63	64						
65	66	67	68	69	70	71	72	73	74	75	76	77	78	79	80	81	82	83	84	85	86	87	88	89	90	91	92	93	94	95	96						
97	98	99	100	101	102	103	104	105	106	107	108	109	110	111	112	113	114	115	116	117	118	119	120	121	122	123	124	125	126	127	128						
B	A	8	4	2	1	NAME										ADDR										B	A	8	4	2	1						
B	A	8	4	2	1	1	2	3	4	5	6	7	8	9	10	11	12	13	14	15	16	17	18	19	20	21	22	23	24	25	26	27	28	29	30	31	32
B	A	8	4	2	1	READ2																				B	A	8	4	2	1						
B	A	8	4	2	1	33	34	35	36	37	38	39	40	41	42	43	44	45	46	47	48	49	50	51	52	53	54	55	56	57	58	59	60	61	62	63	64
B	A	8	4	2	1	65	66	67	68	69	70	71	72	73	74	75	76	77	78	79	80	81	82	83	84	85	86	87	88	89	90	91	92	93	94	95	96
B	A	8	4	2	1																					CODE 1	B	A	8	4	2	1					

READ2 Card

1	2	3	4	5	6	7	8	9	10	11	12	13	14	15	16	17	18	19	20	21	22	23	24	25	26	27	28	29	30	31	32						
33	34	35	36	37	38	39	40	41	42	43	44	45	46	47	48	49	50	51	52	53	54	55	56	57	58	59	60	61	62	63	64						
65	66	67	68	69	70	71	72	73	74	75	76	77	78	79	80	81	82	83	84	85	86	87	88	89	90	91	92	93	94	95	96						
97	98	99	100	101	102	103	104	105	106	107	108	109	110	111	112	113	114	115	116	117	118	119	120	121	122	123	124	125	126	127	128						
B	A	8	4	2	1	NAME										ADDR										B	A	8	4	2	1						
B	A	8	4	2	1	1	2	3	4	5	6	7	8	9	10	11	12	13	14	15	16	17	18	19	20	21	22	23	24	25	26	27	28	29	30	31	32
B	A	8	4	2	1	AMTDUE																				B	A	8	4	2	1						
B	A	8	4	2	1	33	34	35	36	37	38	39	40	41	42	43	44	45	46	47	48	49	50	51	52	53	54	55	56	57	58	59	60	61	62	63	64
B	A	8	4	2	1	65	66	67	68	69	70	71	72	73	74	75	76	77	78	79	80	81	82	83	84	85	86	87	88	89	90	91	92	93	94	95	96
B	A	8	4	2	1																					CODE A	B	A	8	4	2	1					

Amount Due Card

The program must:

- Find the number of kilowatt hours (KWH) of electricity used during the month. The reading has two decimal places.
- Multiply the number of kilowatt hours used by rate per kilowatt hour to find amount due. (AMTDUE has 2 decimal places.) Rate is \$.05 per KWH for the first 50 KWH, then \$.02 per KWH for all over the first 50 KWH.
- Punch the amount due on the appropriate card.
- Separate all three card types into different stackers.

Make the necessary entries on the File Description, Input, Calculation, and Output-Format sheets.

### Stacker Selection

8. If stacker selection is specified on the Output-Format sheet during detail output for card 3, which card will be selected? Which card will be selected if stacker selection is specified during total time output after control group A?

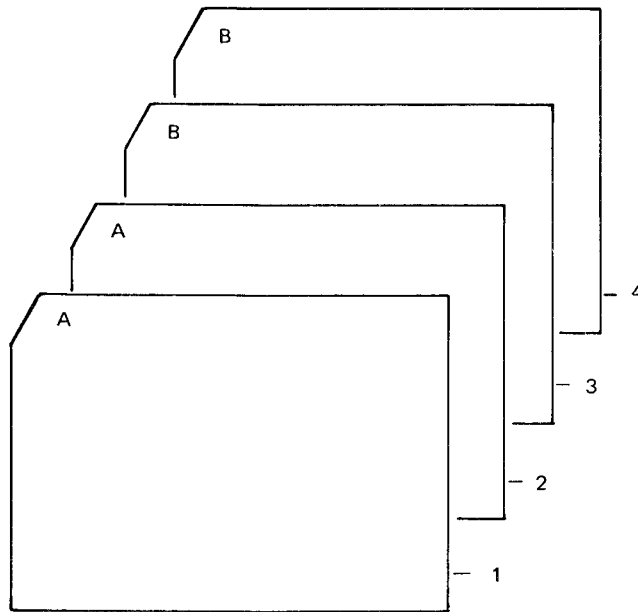

9. At each stop they make, drivers working for a fuel oil company record beginning and ending meter readings and the number of gallons of oil delivered to the customer. Later the account number, meter readings, and gallons delivered are punched into cards.

All regular customers are charged 15¢ per gallon. However hospital and government agencies receive a 2% discount. The code to show which customers receive a discount is in the account field. If the last digit is 0, no discount is given; but if the last digit is 5, the discount is given.

Write the calculation and output-format specifications to:

- Check the driver's calculations in determining gallons delivered to each account by subtracting beginning meter reading from ending meter reading.
- Calculate the amount charged to each account (AMOUNT).
- Find total number of gallons sold for the day (TOTALG) and total amount charged (TOTALA).
- Print a report listing daily transactions and totals. If there is an error in driver's calculations, print the account number, code, and a message, 'CALCULATION ERROR'.
- Stacker select cards for customers receiving discounts into stacker 2. All others go into stacker 3.

The input specifications and the layout of the printed report are as follows:

## RPG INPUT SPECIFICATIONS

GX21 9094 IBM 050  
Printed in U.S.A.

Program		Punching Instruction		Graphic		Card Electro Reader	
Programmer	Date		Punch			Page 1 2 of	Program Identification 75 76 77 78 79 80

Line	Form Type	Filename	Sequence Number (LN)	G R A N D 14 15 16	Record Identifier or ..	Record Identification Codes						Field Location		Field Name	Field Indicators												
						1		2		3		From	To		Plus	Minus	Zero or Blank										
						Position	Character	Position	Character	Position	Character																
0 1	I	CARDS	AA			01	96	C2																			
0 2	I																										
0 3	I																										
0 4	I																										
0 5	I																										
0 6	I																										
0 7	I																										
0 8	I																										
0 9	I																										
1 0	I																										
1 1	I																										
1 2	I																										
1 3	I																										
1 4	I																										
1 5	I																										
1 6	I																										
1 7	I																										
1 8	I																										
1 9	I																										
2 10	I																										

For MFCM, change 96 to 80.

Line	Form Type	Filename	Sequence Number	G R	Record Identifier	Record 1	Record 2	Record 3	Field From	Field To	Field Name	Field Indicators
D						XXXXX.X	XXXXX.X	XXXXX.X	XXXXX.X	XXXXX.XX		
						(ACCTNO)	(BEGIN)	(ENDING)	(GALLON)	(AMOUNT)		
D						XXXXX.X	CALCULATION ERROR					
						(ACCTNO)						
						(CODE)						
T						XXXXXXXXX.X	XXXXXXXXX.XX					
						(TOTALG)	(TOTALA)					

1. Printing the same information that is punched on a card:
  - a. Enables you to easily see what is on the card. You don't have to analyze each punch combination.
  - b. Makes it easier to recreate a card that is damaged to the extent that it cannot be processed.
  
- 2.

IBM		RPG OUTPUT SPECIFICATIONS		GK21 9090 U/M 050* Printed in U.S.A.	
Program				Card Electro Number	
Programmer		Date	Punching Instruction	Page 1 2 of	Program Identification 75 76 77 78 79 80

Line	Form Type	Filename	Type (M/D/T/E)			Space		Skip		Output Indicators					Field Name	Edit Codes	End Position in Output Record	P/B/L/R	Commas	Zero Balances to Print	No Sign	CR	-	X = Remove Plus Sign Y = Date Z = Zero Suppress
			A	D	T	E	Before	After	Before	After	And	And	Not	Not										
01	O	PRINT	D																					
02	O													*AUTO										
03	O													CUSTNO	5									
04	O													NAME	26									
05	O													AMT	32									
06	O													INVNO	38									
07	O													DATE	44									
08	O														96	'2'								
09	O													CUSTNO	*005									
10	O													NAME	*026									
11	O													AMT	*032									
12	O													INVNO	*038									
13	O													DATE	*044									
															*096	'2'								

Solution for MFCU

Line	Form Type	Filename	Type (M/D/T/E)			Space		Skip		Output Indicators					Field Name	Edit Codes	End Position in Output Record	P/B/L/R	Commas	Zero Balances to Print	No Sign	CR	-	X = Remove Plus Sign Y = Date Z = Zero Suppress
			A	D	T	E	Before	After	Before	After	And	And	Not	Not										
01	O	PRINT	D																					
02	O													*AUTO										
03	O													CUSTNO	5									
04	O													NAME	26									
05	O													AMT	32									
06	O													INVNO	38									
07	O													DATE	44									
08	O														64	'2'								
09	O													CUSTNO	105									
10	O													NAME	126									
11	O													AMT	132									
12	O													INVNO	138									
13	O													DATE	144									
14	O														164	'2'								

Solution for MFCM

3.

**IBM** International Business Machine Corporation

**RPG OUTPUT SPECIFICATIONS**

GX21-9090 U/M 050\*  
Printed in U.S.A.

Program		Punching Instruction		Graphic		Card Electro Number	
Programmer		Date		Punch		Page 1 2 of	
						Program Identification 75 76 77 78 79 80	

Line	Form Type	Filename	Type (H/D/T/E)		Space		Skip		Output Indicators				Field Name	End Position in Output Record	P/B/L/R	Constant or Edit Word
			Stacker # / Field #	Field #	Before	After	Before	After	Not	Not	Not	Not				
01	O	PRINT	D										*AUTO			
02	O												CUSTNO	5		
03	O												NAME	26		
04	O												AMT	32		
05	O												INYN	38		
06	O												DATE	44		
07	O													96	'2'	← For MFCM, change 96 to 80.
08	O												*PRINT			

4. A file should be specified as combined if it is both read and punched or if cards from the file are stacker selected on a basis other than card type.
5. Input (stacker selection is on basis of record type here.)
6. False, only card files can be designated as combined files.
- 7.

**File Description Specification**

Line	Form Type	Filename	File Type				Mode of Processing				Device	Symbolic Device	Labels S/N/E/M	Name of Label Exit	Extent Exit for DAM	Core Index	File Addition/Unordered			
			Designation	End of File	Sequence	File Format	Length of Key Field or of Record Address Field	Record Address Type	Type of File Organization or Additional Area	Overflow Indicator							Key Field Starting Location	Extension Code E/L	Number of Tracks for Cylinder Overflow	Number of Extents
02	F	CARDS	CP	E	96	96						MFCU1								
03	F																			

For MFCM, change 96 to 80 and change the device name.

### RPG INPUT SPECIFICATIONS

Form GX21 9094 IBM 9501  
Printed in U.S.A.

Program: \_\_\_\_\_ Date: \_\_\_\_\_ Punching Instruction: \_\_\_\_\_ Graphic: \_\_\_\_\_ Card Electro Number: \_\_\_\_\_  
 Page 1 of 2 Program Identification: 75 76 77 78 79 80

Line	Filename	Sequence Number	Record Identification Codes			Field Location		Field Name	Field Indicators		
			1	2	3	From	To		Plus	Minus	Zero or Blank
01	CARDS	011	01	96	CL						
02							15	NAME			
03							16	ADDR			
04							36	READ1			
05		02L	02	96	C						
06							15	NAME			
07							16	ADDR			
08							36	READ2			
09		03L	03	96	CA						
10							15	NAME			
11							16	ADDR			

For MFCM, change 96 to 80.

### RPG CALCULATION SPECIFICATIONS

Form GX21 9093  
Printed in U.S.A.

Program: \_\_\_\_\_ Date: \_\_\_\_\_ Punching Instruction: \_\_\_\_\_ Graphic: \_\_\_\_\_ Card Electro Number: \_\_\_\_\_  
 Page 1 of 2 Program Identification: 75 76 77 78 79 80

Line	Control Level (LO LB LP, SP, AN, CR)	Indicators			Factor 1	Operation	Factor 2	Result Field		Resulting Indicators	Comments
		And	And	And				Name	Length		
01	C				READ2	SUB	READ1	HOURS	72		
02	C				HOURS	COMP	50			99	
03	C				HOURS	MULT	.05	AMTDUE	72H		
04	C				50	MULT	.05	AMTDUE	H		
05	C				HOURS	SUB	50	HOURS			
06	C				HOURS	MULT	.02	AMT	72H		
07	C				AMT	ADD	AMTDUE	AMTDUE			

IBM		RPG OUTPUT SPECIFICATIONS										GC21-9060 IBM Corp. Printed in U.S.A.		
Program		Date		Punching Instruction		Graphic Function		Card Electro Number		Page 1 2 of Program Identifiers 75 76 77 78 79 80				
Line	Form Input	Filename	Type (H D T E)		Stacker #	Field #	Stacker		Output Indicators		Field Name	Start Position in Output Record	End Position in Output Record	Constant or Edit Word
			A	D			A	D	And	And				
01	O	CARDS	D	2								96	'1'	
02	O													
03	O		D	3										
04	O													
05	O													

For MFCM, change 96 to 80.

Since cards in this file are to be both read and punched the file must be defined as a combined file (C in column 15 of the File Description sheet). The card type identified by a 1 requires no punching, and therefore can be stacker selected on the Input sheet. A 1 was entered in column 42 of the Input sheet to indicate the stacker. Leaving this column blank would also indicate that the card type goes into stacker 1 because cards entered in primary hopper of the MFCU are automatically stacked in stacker 1. Output operations are performed on card types 02 and 03. Stacker selection is, therefore, specified for each on the Output Specifications Sheet in column 16.

8. a. Card 3 — the card that is being processed.  
 b. Card 3 — the card which caused the control break.
- 9.

IBM		RPG CALCULATION SPECIFICATIONS										GC21-9060 IBM Corp. Printed in U.S.A.	
Program		Date		Punching Instruction		Graphic Function		Card Electro Number		Page 1 2 of Program Identifiers 75 76 77 78 79 80			
Line	Form Input	Control Level (LO, LB, LR, SR, AN, OR)	Indicators		Factor 1	Operation	Factor 2	Result Field		Result Indicators	Comments		
			And	And				Name	Length				
01	C		01		CODE	COMP	'5'				02 GIVE DISCOUNT?		
02	C		01		ENDING	SUB	BEGIN	CORREC	6L		CHECK DRIVERS		
03	C		01		CORREC	COMP	GALLON				10 CALCULATIONS		
04	C		10	01	GALLON	MULT	.15	AMOUNT	72H				
05	C		10	02	AMOUNT	MULT	.02	DISC	52H		FIND DISCOUNT		
06	C		10	02	AMOUNT	SUB	DISC	AMOUNT					
07	C		10	01	AMOUNT	ADD	TOTALA	TOTALA	102		ACCUMULATE TOT.		
08	C		10	01	GALLON	ADD	TOTALG	TOTALG	101				
09	C												
10	C												
11	C												
12	C												
13	C												

Program	Punching Instruction	Graphic	Card Electro Number	Page 1 2 of	Program Identification
Programmer	Date	Punch			

Line	Form Type	Filename	TYPE (H/D/T/E)				Space			Skip			Output Indicators			Field Name	End Position in Output Record	Constant or Edit Word
			Stacker # / Fetch(I)	Before		After		Before	After	Not	Not	Not	And	And	And			
				O	R	A	D											
01	O	PRINT	D	I											10 01			
02	O														ACCTNO	7		
03	O														CODE	9		
04	O														BEGIN	1	18	
05	O														ENDINGL	27		
06	O														GALLONL	41		
07	O														AMOUNTL	55		
08	O		D	I											0LN10			
09	O														ACCTNO	7		
10	O														CODE	9		
11	O															27	'CALCULATION ERROR'	
12	O	CARDS	D2												01 02			
13	O		D3												0LN02			
14	O	PRINT	T	2											LR			
15	O														TOTALG1	41		
16	O														TOTALAL	55		
17	O																	
18	O																	
19	O																	
20	O																	

You must be certain to check to see if the code is 5 or 0. The resulting indicator showing the result of the compare is then used on the Output-Format sheet to show into which stacker cards should fall. Stacker selection must be specified as a detail operation so that the correct card will be selected. Any report formatting you choose is acceptable.





## Chapter 5. Controlling Operations In An RPG II Program

### CHAPTER 5 DESCRIBES:

- Additional uses of indicators to control calculations and output.
- Controlling operations on the basis of the next record in a file.
- Manipulating data by moving it from one field to another.
- Saving storage space and coding in calculations by using branching and subroutines.
- Special uses of control level indicators.
- Binary field operations.
- Increasing the speed of RPG II operations.

### BEFORE READING THIS CHAPTER YOU SHOULD BE ABLE TO DESCRIBE:

- General usage of the following indicators: 01-99, MR, L1-L9, LR, 1P, OA-OG, OV.
- The concept of matching records.
- Coding of arithmetic operations in calculations.
- RPG II object program cycle.

### AFTER READING THIS CHAPTER YOU SHOULD BE ABLE TO:

- Control calculations and output using H1-H9, U1-U8, and Resulting Indicators.
- Condition calculations using OA-OG and OV indicators.
- Use the RPG II look ahead feature.
- Code specifications to move data from one field to another.
- Branch in calculations using GOTO and TAG.
- Employ subroutines in calculations using BEGSR, ENDSR, and EXSR.
- Cause an artificial control break and total operations using L0.
- Use control level indicators to perform group printing.
- Control calculations using binary switches.
- State advantages of dual input/output areas and correctly code for them.

*Note:* You can use the review questions contained in *Review 5* at the end of this chapter to test your comprehension of each topic in the chapter. Questions are grouped according to the topic to which they apply. Answers follow the review questions.

## INTRODUCTION

There are many ways that you can control the performance of RPG II operations. You have already learned the basic elements of controlling calculations and output, especially the concept of the RPG II object program cycle and the use of indicators to condition specifications. This chapter supplements those basic concepts by presenting topics that will help you improve the performance of your RPG II programs and do more complex jobs.

## ADDITIONAL USES OF INDICATORS TO CONTROL CALCULATIONS AND OUTPUT

On the Calculation and Output-Format sheets, you describe all the calculations and output to be done in your program. Sometimes, all the calculation and output operations must be performed on every program cycle. More often, however, you want operations done only under certain conditions. For example, you may want to perform a calculation or do some output only when a control break occurs, do an operation only when a certain record type is read, or do certain operations only on certain program runs.

In columns 7-17 (Indicators) of the Calculations sheet and columns 23-31 (Output Indicators) on the Output-Format sheet, you can specify when certain calculation and output operations are to be done. Some of the indicators that can be used, and the conditions they signal, are:

<i>Indicator</i>	<i>Condition</i>
01-99	Operation is done only when a specific record type has been read, or when the result of a calculation or the contents of a field are as desired.
MR	Operation is done only when records match.
L1-L9	Operation is done only when a control break occurs.
LR	Operation is done after all records have been read and processed.
1P	Output record prints only on the first page.
OA-OG; OV	Output record prints only when overflow occurs.

You are probably somewhat familiar with the use of these indicators from previous education, reading, or other topics in this book. However, there are other kinds and uses of indicators with which you may not be so familiar. This section discusses:

1. Halt indicators used to tell what operations should be done on an error condition.
2. External indicators used to tell what operations should be done for a specific program run.
3. Overflow indicators used to tell what *calculations* should be done when overflow occurs.

In addition to these new uses of indicators, this section also describes conditioning of operations based on the results of certain calculations.

### Preventing Operations From Being Done When an Error Occurs

Halt indicators are used to test for an error condition in your data. According to RPG II program logic, a halt does not occur as soon as the error condition is found (as soon as the halt indicator is turned on). Instead, the program cycle is completed before the halt occurs. This means that additional operations may be performed in error unless you specify otherwise.

### Preventing Calculations When an Error Occurs

Specifications shown in Figure 5-1 illustrate the use of H1 to prevent calculations. Tests are made to determine if the INSTOK, TOTAL, or ORDER fields on record types 01, 02, or 03, respectively, are negative. A negative value in any of these fields is an error condition. When an error is found, H1 turns on. Since calculations [normally] are done when 02 and 03 record types are read, conditioning these calculations by NH1 prevents them from being done when data is erroneous.

Halt indicators can also be specified on the Calculation sheet to test for an error. For example, in Figure 5-2, H1 is set on if the result of operation in line 01 is negative. If quantity in stock (INSTOK) is negative after quantity shipped (QTYSH) has been subtracted, an error has occurred. H1 turns on and the system will halt after the current cycle.

### RPG INPUT SPECIFICATIONS

Form GX21-9094 U/M 050\*  
Printed in U.S.A.

IBM International Business Machine Corporation		Card Electro Number		Page 1 of 2		Program Identification 75 76 77 78 79 80	
Program	Date	Punching Instruction	Graphic Punch				
Programmer							

Line	Form Type	Filename	Sequence	Record Identification Codes									Field Location		Field Name	Control Level (L1-L5)	Matching Fields or Chaining Fields	Field Record Relation	Field Indicators		
				Position	Not (N) Character	Position	Not (N) C/Z/D Character	Position	Not (N) C/Z/D Character	From	To	Plus	Minus	Zero or Blank							
01	I	MONTHRPT	Ø11 Ø1	9b CA									1	8	ITEMNOLL						
02	I												9	14	DATE						
03	I												15	23	INSTOK						HI
04	I		Ø2N Ø2	9b CS									7	14	ITEMNOLL						
05	I												39	45	TOTAL						HI
06	I		Ø3NØ3	9b CL									1	8	ITEMNOLL						
07	I												9	14	DATE						
08	I												15	22	ORDER						HI

### RPG CALCULATION SPECIFICATIONS

Form GX21-9093  
Printed in U.S.A.

IBM International Business Machine Corporation		Card Electro Number		Page 1 of 2		Program Identification 75 76 77 78 79 80	
Program	Date	Punching Instruction	Graphic Punch				
Programmer							

Line	Form Type	Control Level (L0-L9)	Indicators			Factor 1	Operation	Factor 2	Result Field		Resulting Indicators				Comments
			And	And	And				Name	Length	Arithmetic	Plus	Minus	Zero	
01	C		Ø2NH1			INSTOK	SUB	TOTAL	INSTOK						
02	C		Ø3NH1			INSTOK	ADD	ORDER	INSTOK						
03	C														

Figure 5-1. Conditioning Calculations by a Halt Indicator

### RPG CALCULATION SPECIFICATIONS

Form GX21-9093  
Printed in U.S.A.

IBM International Business Machine Corporation		Card Electro Number		Page 1 of 2		Program Identification 75 76 77 78 79 80	
Program	Date	Punching Instruction	Graphic Punch				
Programmer							

Line	Form Type	Control Level (L0-L9)	Indicators			Factor 1	Operation	Factor 2	Result Field		Resulting Indicators				Comments
			And	And	And				Name	Length	Arithmetic	Plus	Minus	Zero	
01	C					INSTOK	SUB	QTYSH	INSTOK						HL
02	C														

Figure 5-2. Testing Result Field for Error Conditions

**Preventing an Entire Record From Being Written**

Figure 5-3, line 07, shows an output operation conditioned so that the record specified will be written only when the halt indicator is not on (NH1). When the halt indicator is on (H1), it will be bypassed.

**Preventing Fields From Being Written**

Suppose, however, that you do not want to bypass the writing of the entire record, but want some fields written even when a halt condition occurs. For this case you should use the halt indicator to condition certain fields within the record instead of conditioning the entire record. This way, when an error occurs, some fields will be written and some will not.

Figure 5-4 shows the specifications which will bypass the writing of all fields except DEPT and ITEMNO when an error occurs.

**Doing Output Only When an Error Occurs**

It is also possible to condition records or fields so that they are written only when an error condition occurs. Figure 5-5 shows the specifications which do this.

Using the halt indicator will cause the computer to stop after all operations are completed for the record causing the error. You may restart processing immediately, however, by pressing the start button on the processing unit.

**IBM** International Business Machine Corporation GX21 9090 U/M 050\*  
Printed in U.S.A.

**RPG OUTPUT SPECIFICATIONS**

Program \_\_\_\_\_ Punching Instruction \_\_\_\_\_ Graphic \_\_\_\_\_ Card Electro Number \_\_\_\_\_  
 Programmer \_\_\_\_\_ Date \_\_\_\_\_ Punch \_\_\_\_\_ Page 1 2 of \_\_\_\_\_ Program Identification 75 76 77 78 79 80

Line	Form Type	Filename	Type (H/D/T/E)			Space	Skip		Output Indicators					Field Name	Edit Codes B/A/C/1/9/R	End Position in Output Record	PUBLI/R	Constant or Edit Word
			A	D	T		E	Before	After	Not	Nil	Not	And					
01	O	OUTPUT																
02	O		H															
03	O		OR															
04	O																	
05	O																	
06	O																	
07	O																	
08	O																	
09	O																	
10	O																	
11	O																	
12	O																	
13	O																	
14	O																	
15	O																	

When H1 is on, this record is not written out.

Commas	Zero Balances to Print	No Sign	CR	-	X	Remove Plus Sign
Yes	Yes	1	A	J	Y	Date
Yes	No	2	B	K	Y	Field Edit
No	Yes	3	C	L	Z	Zero Suppress
No	No	4	D	M		

Figure 5-3. Preventing a Record from Printing

<b>RPG OUTPUT SPECIFICATIONS</b>																														GX21-9090 U/M 050* Printed in U.S.A.							
Program _____						Punching Instruction _____			Graphic _____			Card Electro Number _____			Page 1 2 of _____			Program Identification 75 76 77 78 79 80																			
Programmer _____						Date _____			Punch _____																												
Line	Form Type	Filename	Type (H D T E)			Space		Skip		Output Indicators			Field Name	Edit Codes	End Position in Output Record	P/B L/R	Options																				
			Q	A	N	D	Before	After	Before	After	Not	And					And	Not	Commas	Zero Balances to Print	No Sign	CR	-	X	Remove Plus Sign												
1	O	OUTPUT	H			2	0	1			LI																										
2	O	OR									OVNLI				25																						
3	O														40																						
4	O														70																						
5	O														80																						
6	O		D				1				LI				25																						
7	O										NHI				40																						
8	O										NHI				75																						
9	O										LI				80																						
10	O														74																						
11	O		T				2				LI				80																						
12	O																																				
13	O																																				
14	O																																				
15	O																																				
16	O																																				

When H1 is on, these fields are not written out.

Figure 5-4. Preventing Fields from Being Written

<b>RPG OUTPUT SPECIFICATIONS</b>																														GX21-9090 U/M 050* Printed in U.S.A.							
Program _____						Punching Instruction _____			Graphic _____			Card Electro Number _____			Page 1 2 of _____			Program Identification 75 76 77 78 79 80																			
Programmer _____						Date _____			Punch _____																												
Line	Form Type	Filename	Type (H D T E)			Space		Skip		Output Indicators			Field Name	Edit Codes	End Position in Output Record	P/B L/R	Options																				
			Q	A	N	D	Before	After	Before	After	Not	And					And	Not	Commas	Zero Balances to Print	No Sign	CR	-	X	Remove Plus Sign												
1	O	OUTPUT	H			2	0	1			LI																										
2	O	OR									OVNLI				25																						
3	O														40																						
4	O														70																						
5	O														80																						
6	O		D				1				LI				25																						
7	O										NHI				40																						
8	O										NHI				74																						
9	O										NHI				80																						
10	O										LI				80																						
11	O														74																						
12	O		T				2				LI				80																						
13	O																																				
14	O																																				
15	O																																				
16	O																																				

This constant prints only when an error condition occurs.

Figure 5-5. Doing Output When an Error Occurs

*Using Indicators Other Than H1-H9 to Bypass Error Conditions*

If you are not interested in halting when an error condition occurs but still wish to bypass the processing of erroneous data, you may use indicators 01-99 instead. They, like halt indicators, may be assigned to check for error conditions in

data on the Input sheet and are then later used to condition calculations and output operations (see Figure 5-6). They do not cause a halt.

When you do not wish to halt the program for an error condition, you may select cards into a special stacker so that they will not be mixed with valid data cards. Stacker selection may be done based on the use of the indicator for an error condition.

**IBM** International Business Machines Corporation

Program \_\_\_\_\_  
 Programmer \_\_\_\_\_ Date \_\_\_\_\_

**RPG INPUT SPECIFICATIONS**

Page 1 2 of \_\_\_\_\_

GX21 9094 U/M 050  
 Printed in U.S.A.

Program Identification 75 76 77 78 79 80

Line	Filename	Sequence	Record Identification Codes									Field Location		Field Name	Field Indicators					
			1	2	3	4	5	6	7	8	9	From	To		Plus	Minus	Zero or Blank			
01	CARDS	AA	01	96	CC															
02	OR	OR	02	96	CB															
03																				
04																				
05																				
06																				
07																				
08																				

**IBM** International Business Machines Corporation

Program \_\_\_\_\_  
 Programmer \_\_\_\_\_ Date \_\_\_\_\_

**RPG OUTPUT SPECIFICATIONS**

Page 1 2 of \_\_\_\_\_

GX21 9090 U/M 050  
 Printed in U.S.A.

Program Identification 75 76 77 78 79 80

Line	Filename	Form Type	Space	Skip	Output Indicators			Field Name	End Position in Output Record	Constant or Edit Word
					And	And	And			
01	OUTPUT	H	2	01	LL			25	'DEPT'	
02	OR	OR			OVNLL			40	'ITEM NO'	
03								70	'DESCRIPTION'	
04								80	'ONHAND'	
05								25	'DEPT'	
06								40	'ITEM NO'	
07								74	'DESCRIPTION'	
08								80	'ONHAND'	
09								25	'DEPT'	
10								40	'ITEM NO'	
11								74	'DESCRIPTION'	
12								80	'ONHAND'	
13								74	'IN STOCK AS OF'	
14								80	'ONHAND'	
15										

Figure 5-6. Using Indicators 01-99 to Prevent Output

## Controlling Which Operations are Done For a Specific Program Run

The chapter entitled *Describing and Using Input* describes how to condition the use of an input file with an external indicator so that a program can use different input files in different program runs. That chapter also describes how to assign external indicators U1-U8 on the File Description sheet and how to set the indicators.

This section describes how external indicators are used on the Calculation and Output-Format sheets to condition which operations should be done for a specific program run.

## Conditioning Input Files and Related Calculations

Consider for example, calculations done for a sales analysis program. For each item in stock, monthly total sold (SOLD) is calculated and then added to last month's year-to-date total (BALFOR) to find the current year-to-date total (BALNCE). In the first month of a new year, monthly totals should not be added to prior year-to-date totals because totals are not carried over from year to year. This last statement, the year-to-date addition statement, therefore, is not done for all program runs. By conditioning the statement with an external indicator, you can control when the statement is done. In Figure 5-7, the monthly total is added to prior year-to-date only when U1 is on.

When one program is written to do two similar, yet unique, applications, some calculations may be used for both applications, some for only one. Again you may use external indicators to control which calculation specifications are used for each application.

RPG CALCULATION SPECIFICATIONS																																																																						Form GX21-9093 Printed in U.S.A.	
IBM International Business Machine Corporation										Punching Instruction										Graphic										Card Electro Number										Page 1 2 of		Program Identification 75 76 77 78 79 80																													
Program										Punch																																																													
Programmer										Date																																																													
Line	Form Type	Control Level (L, O, L9, LR, SR, AN/OR)	Indicators								Factor 1	Operation	Factor 2	Result Field		Decimal Positions	Resulting Indicators			Comments																																																			
			And	And	Not	Not	Name	Length	Arithmetic	Plus				Minus	Zero																																																								
0 1	C		U1	MR					BALFOR	ADD	SOLD	BALNCE	70																																																										
0 2	C																																																																						

Figure 5-7. Conditioning a Calculation by an External Indicator





Because the results differ slightly for each job, different output operations are required. When two jobs are coded together, you indicate which operations are to be done for each through the use of an external indicator by setting the indicator to signal which files are to be used. You can specify which output operations should be done in the same way—by conditioning them by the same external indicator.

The Output-Format sheet shown in Figure 5-10 shows specifications for both jobs. Appropriate heading and detail lines are given for each. The total record is only for the balance forward job. Unless told otherwise, the computer will try to perform all specifications (provided conditions set by indicators in columns 23-31 are satisfied) in each cycle. You, therefore, have to tell the computer which operations to do for each job.

The file description specifications (Figure 5-9) show that when U1 is on, the MASTER file is used. This means that the inventory job is being done. Thus when U1 is on, only the output specifications to print records for the balance inventory are needed. Condition those output records on U1 (Figure 5-10, lines 01, 05, 10, 12, 15, 22). Condition those for the sales analysis job on NU1 (when U1 is not on the MASTER file is not used).

**Conditioning Output Files and Related Output Operations**

The program just discussed involves the use of a variable number of input files. One program may also require the use of a variable number of output files. In that case, the output file must be assigned an external indicator. When the indicator is on, the file is used. When it is off, the file is not used.

IBM International Business Machine Corporation			RPG OUTPUT SPECIFICATIONS		GX21 9090 U/M 0500 Printed in U.S.A.										
Program		Date		Punching Instruction	Graphic Punch	Card Electro Number									
Programmer						Page 1 2 of 75 76 77 78 79 80									
Line	Form Type	Filename	Type (H/D/T/E)		Space		Skip			Output Indicators			Field Name	End Position in Output Record	Constant or Edit Word
			Stacker # / Fetch (F)	Before	After	Before	After	Not	Not	Not	And	And			
01	O	PRINT	H	3										56	'BALANCE FORWARD'
02	O														
03	O		H	3										56	'SALES ANALYSIS'
04	O														
05	O		H	2										29	'ITEM NUMBER'
06	O													40	'AMOUNT SOLD'
07	O													47	'DATE'
08	O													63	'BALANCE'
09	O														
10	O		D	0											
11	O													25	ITEM
12	O		D	2											
13	O													35	SOLD
14	O													50	DATE
15	O		D	2											
16	O													25	ITEM
17	O		D	2											
18	O		OR	22											
19	O													25	ITEM
20	O													35	SOLD
21	O													50	DATE
22	O		T	3										60	BALNCEZ
23	O													60	
24	O													61	'*'

Figure 5-10. Conditioning Output Operations by an External Indicator

For example, consider a sales analysis job which does the following:

1. Calculates and records the quantity of each item sold during the month.
2. Updates the year-to-date total of the number of each item sold.
3. Creates a new year-to-date record.

the current-year-to-date total is punched. Notice that the new year-to-date summary card is stacker-selected into stacker 1, the default stacker for the primary MFCU hopper (Figure 5-11, line 11 of the Output sheet). Assume that the old summary card is selected into a different stacker by means of an entry in column 42 of the input specifications. Thus, the new summary card is automatically placed into the item file in preparation for the next run of the program, while the old summary card can be easily discarded.

The input file, organized in ascending order by item number, consists of two record types: (1) item cards, and (2) summary YTD cards. Each item card represents an item transaction. During the job, item cards are counted; and, when a control break occurs, amount sold is added to the year-to-date total found on the summary card. The number sold and current year-to-date totals are recorded on the sales analysis report, and a new summary card containing

At the end of the year, new year-to-date summary cards should not be punched because the year-to-date total is not carried over into the next year. In this case, the punching operations should not be done. You can tell the program whether or not to punch by conditioning the output operations and the output file by the same external indicator. Figure 5-11 shows some of the specifications for the job.

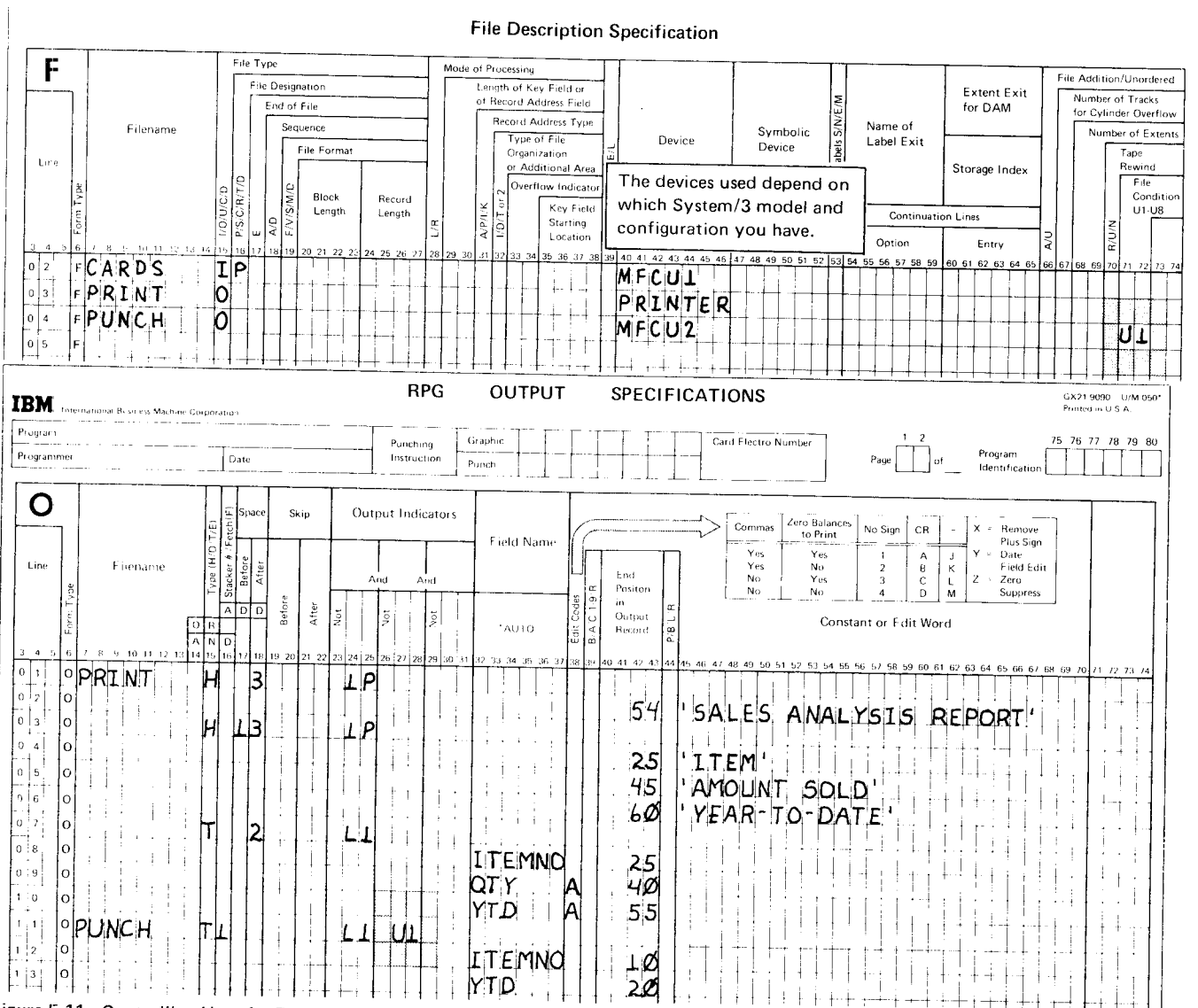

Figure 5-11. Controlling Use of a File

Always be sure to control which calculation and output operations should be done for the job being run by conditioning the operations with the same external indicators that were assigned to the file. When you condition input files by external indicators, you *may* condition output operations if you desire. However when you condition output files, you must use the same external indicator used for conditioning the output operations. If you forget to condition the records for an output file conditioned by an external indicator, an error will occur.

### Conditioning Output Operations Only

So far, you have learned that external indicators condition files and operations related to the use of that file. External indicators need not always condition a *file*; they can condition output operations only. This means that every time the program is run, the same files will be used, but different output operations are done depending upon the setting of the external indicators.

For example, just one specification conditioned by an external indicator can change a group-printed report to a group-indicated report or vice versa. Figure 5-12, part A, shows that a detail line will print for every card. By adding an external indicator, you can control whether or not the detail line will print (Figure 5-12, part B). When U1 is on, the line prints; when U1 is not on, it will not print.

### Controlling Calculations When Overflow Occurs

You normally think of using an overflow indicator to condition total or heading records that must be printed on every page of a report. But you may also use the overflow indicator to condition calculation operations. Any calculation operation so conditioned will be performed only when overflow occurs.

IBM International Business Machine Corporation			RPG OUTPUT SPECIFICATIONS			GX21-9090 U/M 0500 Printed in U.S.A.					
Program	Punching Instruction	Graphic Punch	Card Electro Number	Page 1 of 2	Program Identification	75	76	77	78	79	80
Programmer	Date										
Line	Filename	Output Indicators	Field Name	End Position in Output Record	Commas	Zero Balances to Print	No Sign	CR	-	X	Remove Plus Sign
01	PRINT	D 2	DEPTNO	15	Yes	Yes	1	A	J		
02			ITEM	35	Yes	No	2	B	K	Y	Date
04			DESC	55	No	Yes	3	C	L	Z	Field Edit
05			PRICE	65	No	No	4	D	M		Zero Suppress
06	T 1	L 1	TOTAL	65	Constant or Edit Word						
07											
08	*PRINT	D 2	DEPTNO	15							
09			ITEM	35							
10			DESC	55							
11			PRICE	65							
12			TOTAL	65							
13											
14	T 1	L 1									
15											
16											
17											
18											
19											
20											

Figure 5-12. Using U1 to Condition Output Operations

Assume, for example, that you are preparing an accounts receivable report as shown in Figure 5-13. On each page of the report, you wish to have a total showing the amount of all accounts receivable on that page. You also wish to find the total amount of all accounts receivable on all pages.

Thus at the beginning of each page, you must start accumulating totals for that page. When *overflow* occurs you want to add the amount of the accounts received (page total) to final total, print the page total and then reset the page total to zero so that you can start accumulating totals for the next page. Only the calculations which are to be done when overflow occurs are conditioned by the overflow indicator. See Figure 5-14 for the calculation specifications.

### Performing Calculations on the Basis of the Results of Other Calculations

The value of the contents of a field rather than the occurrence of a certain condition can be used to determine whether or not an operation will be performed. You have worked with such situations already. For example, you have used a field on an input record to determine if processing should be done. If the field was positive, you wanted to do all calculations; if it was negative, you did *no* calculations. (See *Preventing Calculations When an Error Occurs.*)

For the situation just stated the contents of an input field determined what calculations (if any) were done. In this section, however, emphasis will be placed upon how results obtained in a calculation operation can be used to determine whether or not other calculations are performed.

DATE 06/30/0		ACCOUNTS RECEIVABLE REGISTER		PAGE 1
CUST NO	ACCOUNT NAME	INV DATE MO/DY/YR	ACCOUNTS RECEIVABLE	
11886	AABY, SHELLEY	4/18/0	86.40	
12093	ACKER, ALVIN	4/18/0	403.10	
12128	ADAMS, CINDY	4/18/0	345.05	
12206	ADSON, MARION	4/18/0	700.60	
12720	ANTON, MONICA	4/18/0	1,253.40	
12803	AXFORD, JOE	4/18/0	48.52	
12815	BAILEY, MARLYS	4/18/0	107.05	
12900	BALZUM, GERALD	4/18/0	345.10	
13260	BATTEY, ADA	4/18/0	165.35	
13265	BEABOUT, ART	4/18/0	316.05	
12390	BERGERSON, M.	4/18/0	43.60	
14619	BILSTAD, DON	4/18/0	1,129.02	
			4,943.24	PAGE TOTAL

Figure 5-13. Report with Page Totals

C		Form Type Control Level (L, O, L, R, SR, AN, OR)	Indicators						Factor 1	Operation	Factor 2	Result Field		Decimal Positions Half Adjust (H)	Resulting Indicators			Comments
Line			And	Not	And	Not	And	Not				Name	Length		Plus	Minus	Zero	
01	C							PGTOT	ADD	ACCT	PGTOT	82						
02	C	OV						PGTOT	ADD	FINTOT	FINTOT	92						
03	C																	

Figure 5-14. Conditioning a Calculation by an Overflow Indicator

### Using the Results of Arithmetic Operations

Consider how the result of a calculation can be used to determine the need for further calculations in a billing program. For each account, it is necessary to first determine the amount owed by adding charges and payments (payments are recorded as negative numbers) to the balance due at the beginning of the month. For any customer owing money at the end of the month, a service charge of 1-1/2 percent is added to the amount due. If he has credit coming, he must be sent a credit memo instead of a bill. Thus a test must be made on the amount due field to determine if it is plus or minus. If it is plus, the customer owes money and the service charge must be figured before the bill is printed. If it is minus, he has a credit and must be sent a credit memo. The card for the customer with a minus balance is stacked into a special hopper. It is later used in a credit memo run.

How can you cause a test to be made on the data? Remember in Figure 5-1 how you tested for a minus quantity. By entering an indicator (01-99, H1-H9) in columns 54-59, you can test for plus, minus, or zero depending upon where you place the indicator.

For this program, indicator 99 is placed in columns 54-55 to test for a plus condition (see Figure 5-15). When a control break occurs (all transactions for one account are processed) and when 99 is on, the 1-1/2 percent service charge is found and added to amount due (AMTDUE) to find total amount due.

If indicator 99 is off (no amount due) when the control break occurs, these last two operations are not performed.

C		Form Type Control Level (L, O, L, R, SR, AN, OR)	Indicators						Factor 1	Operation	Factor 2	Result Field		Decimal Positions Half Adjust (H)	Resulting Indicators			Comments
Line			And	Not	And	Not	And	Not				Name	Length		Plus	Minus	Zero	
01	C		02						Z-ADDBALANC	AMTDUE	62							
02	C		01					AMTDUE	ADD	TRANS	AMTDUE	9998						
03	C	LI	99					AMTDUE	MULT	.015	CHARGE	62H						
04	C	LI	99					CHARGE	ADD	AMTDUE	AMTDUE							
05	C																	

Figure 5-15. Conditioning Calculations by an Indicator Set as a Result of an Arithmetic Operation







You can use TESTZ to test for any special code you set up by using the zone of a character. This is most often done when you have no space on your records for any other kind of identifying information. For example, when establishing a code for the percentage of commission received by each salesman, you could use the & to indicate 6 percent and the minus (-) sign to indicate 15 percent. You would, of course, have to punch this code in the leftmost position of a numeric field because this is the position tested by the

TESTZ operation. Figure 5-19 shows how the code is placed in the field containing salesman number. However, you must define the field as alphameric since the TESTZ operation can only be performed on an alphameric field.

Figure 5-20 shows the TESTZ used on the SALSNO (salesman number) field, which contains the commission code, in order to find rate of commission. The results of the test determines what other calculations will be done.

SALESMAN -

Whose number is 17657778

Who earns 15% commission

Has 17657778 punched in SALSNO field

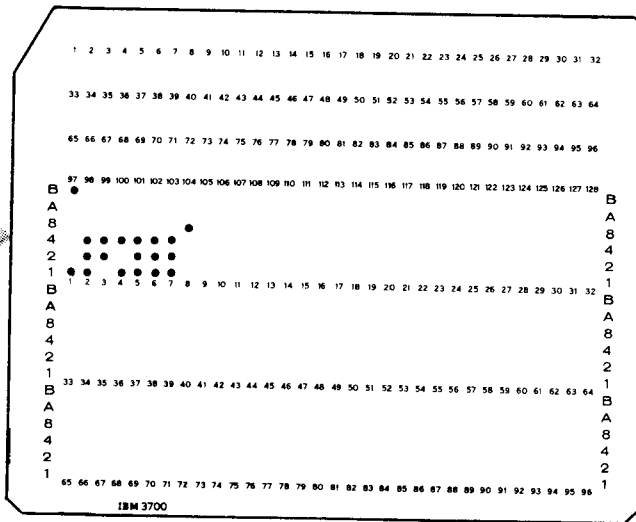

Figure 5-19. Punching a Code

IBM International Business Machine Corporation		RPG CALCULATION SPECIFICATIONS		Form GX21-9093 Printed in U.S.A.					
Program			Punching Instruction	Graphic	Card Electro Number				
Programmer			Date	Punch					
Page 1 of 2 Program Identification 75 76 77 78 79 80									
Line	Form Type	Control	Indicators	Factor 1	Operation	Factor 2	Result Field	Resulting Indicators	Comments
0 1	C	MR 02			TESTZ		SLSNO	IS ZONE E OR -?	
0 2	C	L0 MR 02 SALES			MULT .06		COMM 62H	IF E USE 6%	
0 3	C	L1 MR 02 SALES			MULT .15		COMM 62H	IF - USE 15%	

Figure 5-20. Testing a Field to Determine a Code

## CONTROLLING OPERATIONS ON THE BASIS OF THE NEXT RECORD IN A FILE

Sometimes, calculations to be performed may depend upon information in the next record or on the type of the next record to be processed. For example, in a certain kind of program, you might want to bypass calculations for the current record if you know the next record in the file is identical.

The RPG II language has a special feature called *look ahead*, which extends the basic RPG II logic. It will allow the computer to look at information in the next record to be processed while it is processing the current record. This means that information in record B can be used while record A is being processed. By using this feature, you can write a program that uses information from the next record available for processing.

Look ahead can be used with card, tape, or disk input files. This section discusses look ahead with card (MFCU) and disk files. For MFCM, tape, and other files, the concept is similar.

## Processing Card or Disk Files

**MFCU Files:** (Refer to the representation of the MFCU card path in Figure 5-21 during this discussion.) As Card A is read, data recorded on it is transferred to the input area. The card then moves on to the wait station. According to the RPG II program cycle, information is transferred from the input area to the processing area right before detail time. At detail time, then, calculations can be done on data from the card path which is in the wait station (Card A).

However, when look ahead is specified, another card (Card B) is read before detail time operations are performed in the current cycle. Card A is stacked and information from Card A is moved to the processing area. Then information on Card B just read is transferred to the input area and is available for use while processing Card A, now in the stacker.

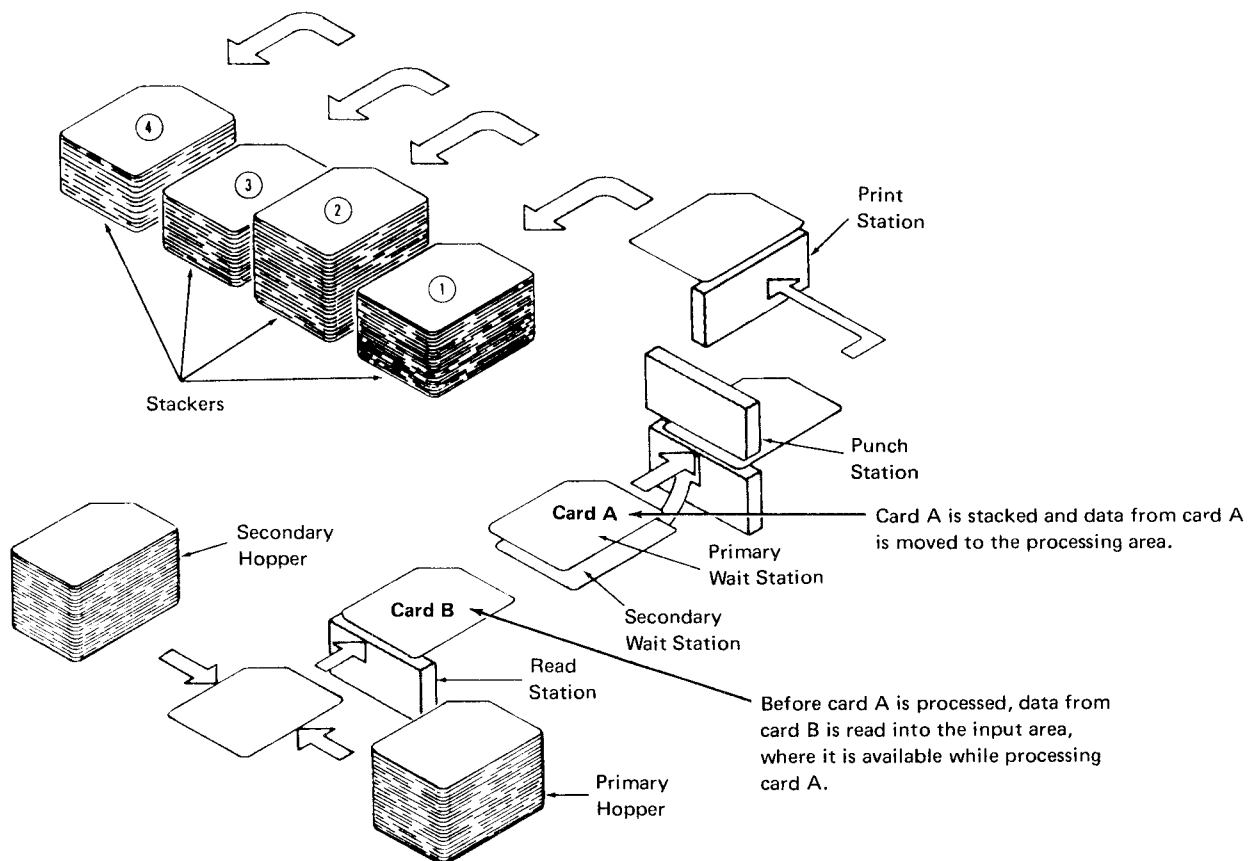
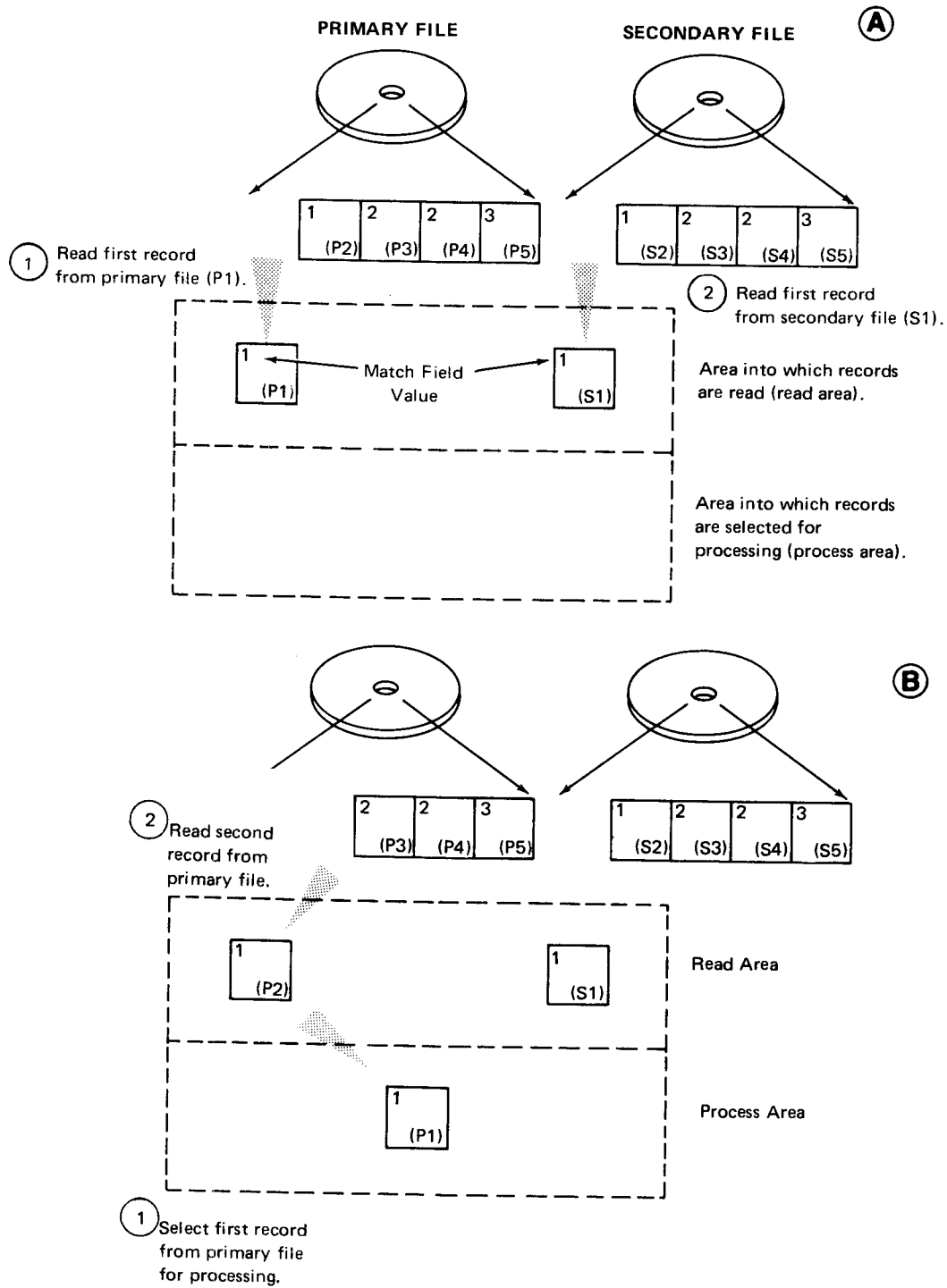

Figure 5-21. The Look Ahead Function with a Card File

**Disk Files:** Figure 5-22 shows processing of three of the records from two disk input files, one primary and one secondary. The records available for look ahead during the processing of these records are:

Record Processed	Records Available
P1	P2 and S1
P2	P3 and S1
S1	P3 and S2



**Figure 5-22 (Part 1 of 2). Records Available for Look Ahead: Two Input Files**

In general, when the record being processed is from an input file, the next record in the input file is available as the records which were read but not processed from the other files.

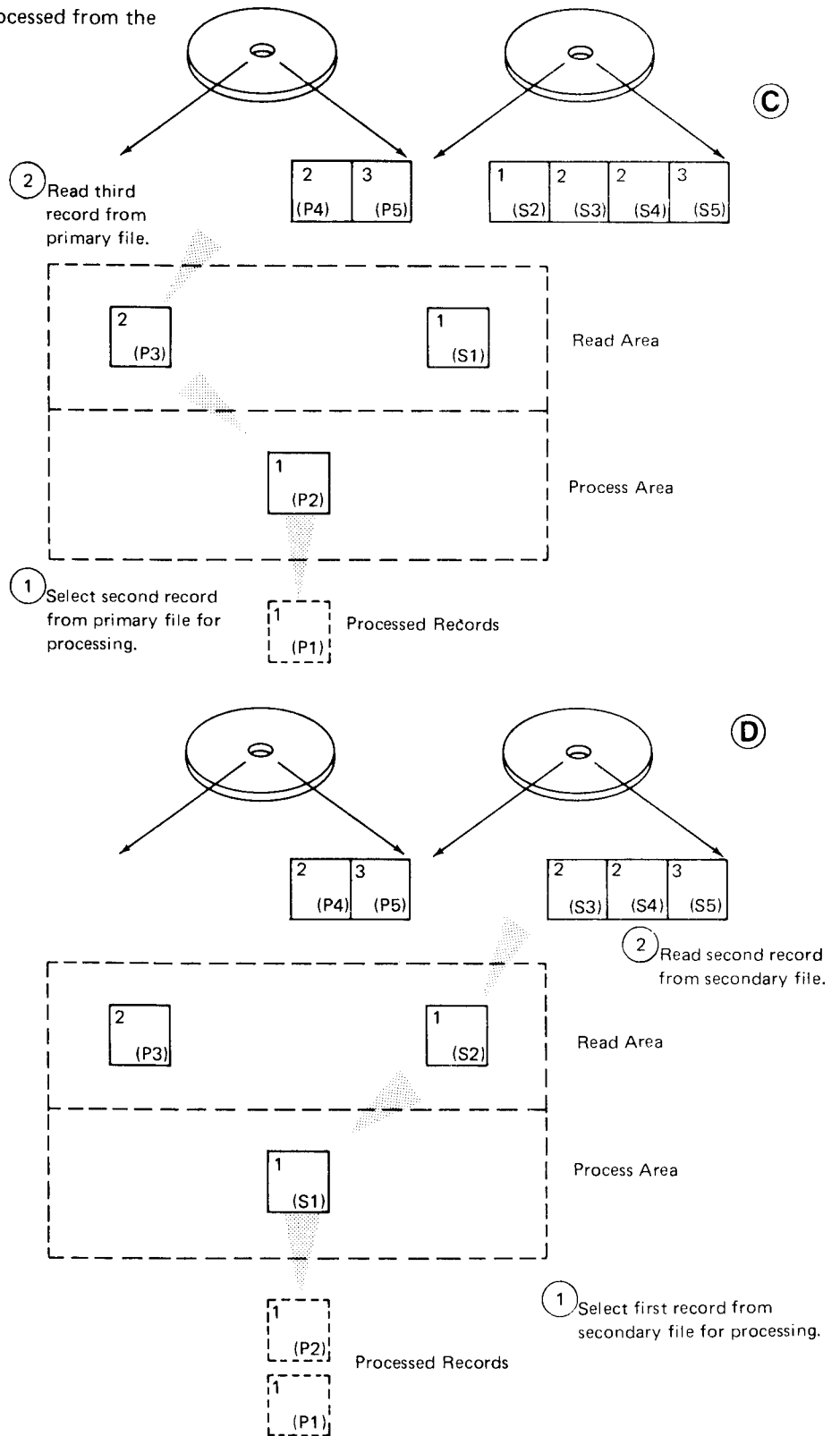

Figure 5-22 (Part 2 of 2). Records Available for Look Ahead: Two Input Files



All look ahead fields must be defined as being in a record type different from the others defined. This is done by using a unique alphabetic sequence entry in columns 15-16. No record identifying indicator (01-99) can be used. A double asterisk (\*\*) is placed in columns 19-20 to specify that the fields described in the following lines are look ahead fields. Field location is also specified for look ahead fields.

Every look ahead field must be named, but the name given must be different than when it was described as a normal input field. The same field is given two names so that you can distinguish between the field on the record being processed and that same field (the look ahead field) on the record that is to be processed next (Figure 5-24).

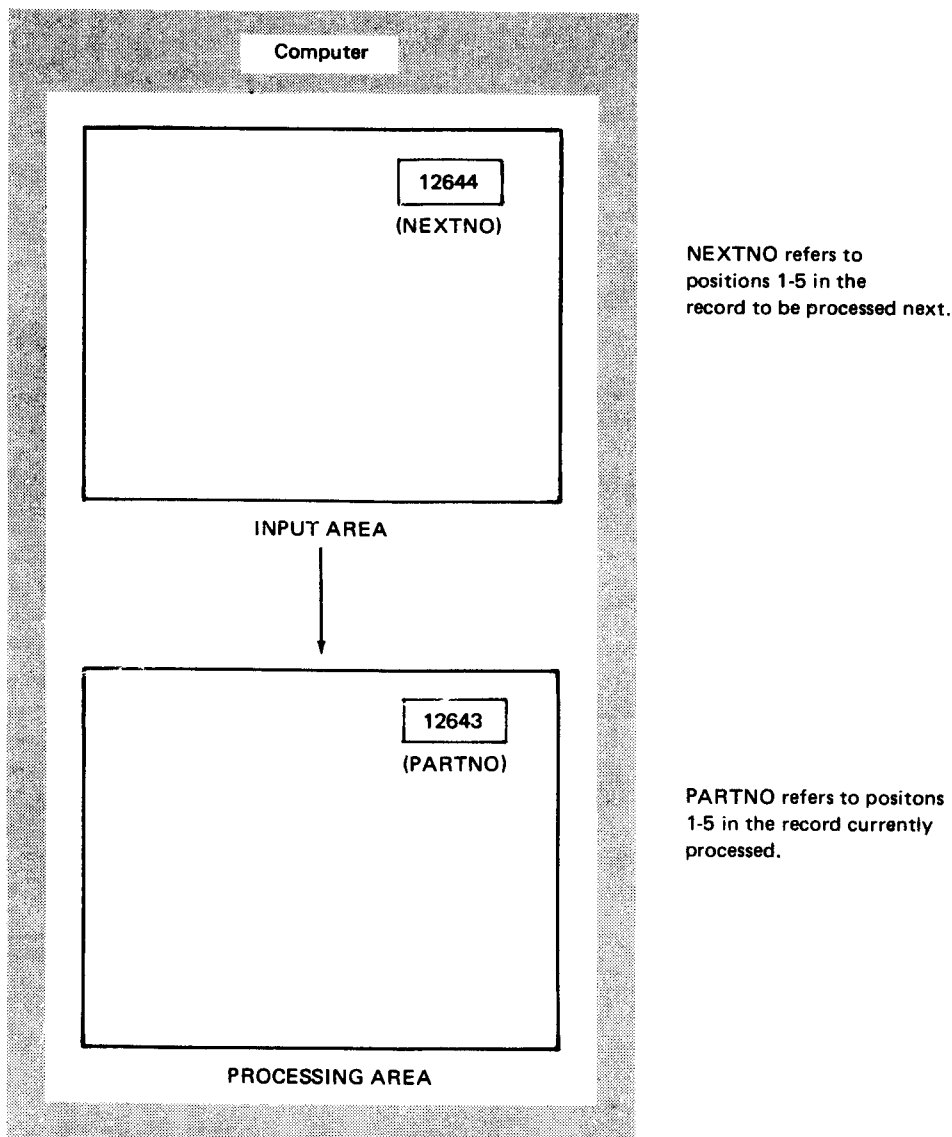

Figure 5-24. Look Ahead Field: A Field with Two Names

**Using Look Ahead Information**

Now that you have specified the look ahead field, you can use it as you would any other field. The only exceptions are that you cannot use it as a result field in calculations, nor can it be blanked after for output.

In the listing program, you have to make a comparison between part numbers from two records. If PARTNO on the record being processing is the same as NEXTNO on the next record to be processed, you wish to print a message indicating duplicate entries. If the PARTNO and NEXTNO fields do not match, there are no duplicates for that part number, and the item is merely listed.

Figure 5-25 shows specifications for the program. The operation in line 01 of the Calculation sheet compares the part number on the record being processed (PARTNO) to the part number on the record coming next (NEXTNO). If

they are equal, indicator 07 is turned on. Notice on the Output-Format sheet that when 07 is on, the word *duplicate* is printed.

The SETON and SETOF operations in lines 02-04 of the Calculation sheet are used so that the computer will indicate a duplicate when the second record having the duplicate part number is processed.

Consider, for example, records A1, A2, and B. The first two records are duplicates; the third is not. When A1 is processed, the program looks ahead to A2 and, by comparing, knows that A2 is the same as A1. When A2 is processed, the program looks ahead to B. The compare will say that A2 is not a duplicate since it does not match B1. But A2 really is a duplicate because it is the same as A1. Thus, when processing A1, you have to set an indicator which will be on when A2 is processed and which will indicate that A2 is a duplicate since it matches the previous record.

IBM		RPG CALCULATION SPECIFICATIONS		Form GX21 9093 Printed in U.S.A.									
Program		Punching Instruction		Card Electro Number									
Programmer		Date		Page 1 2 of Program Identification 75 76 77 78 79 80									
Line	Form Type	Indicators						Factor 1	Operation	Factor 2	Result Field		Comments
		Control Level (L/D/LB)	And	And	Not	Not	Not				Name	Length	
3	C												
01	C						PARTNO	COMP	NEXTNO				
02	C		07					SETON			51	07	
03	C		51	07				SETON			52	07	
04	C		51	52				SETOF			5152		

IBM		RPG OUTPUT SPECIFICATIONS		Form GX21 9090 U/M 0507 Printed in U.S.A.								
Program		Punching Instruction		Card Electro Number								
Programmer		Date		Page 1 2 of Program Identification 75 76 77 78 79 80								
Line	Form Type	Filename	Output Indicators						Field Name	End Position in Output Record	P/B/L/R	Constant or Edit Word
			Type (H/D/T/E)	Space	Skip	And	And	Not				
01	O	PRINT	D	2			01					
02	O							PARTNO	25			
03	O							DESC	60			
04	O						07	ONHANDL	75			
05	O								90		'DUPLICATE'	

**Figure 5-25. Using Information from the Look Ahead Field to Check for Duplicates**

When PARTNO equals NEXTNO, 07 turns on. This, in turn, causes indicator 51, which is used to indicate that a duplicate record is processed, to turn on. During the next program cycle, the compare does not indicate duplicates; therefore 07 is not on. But 51 *is* on, meaning that the record being processed is a duplicate since the part number on it matched the part number on the previous record. Therefore, 07 is set on. Remember 07 conditions those output operations which are to be done for duplicates.

Indicator 52 is set on in line 03 to indicate that the last duplicate record is being processed. Indicator 52 then conditions line 04 so that indicator 51 will be set off and not indicate duplicates in the following cycle. Figure 5-26 shows the program logic for this job.

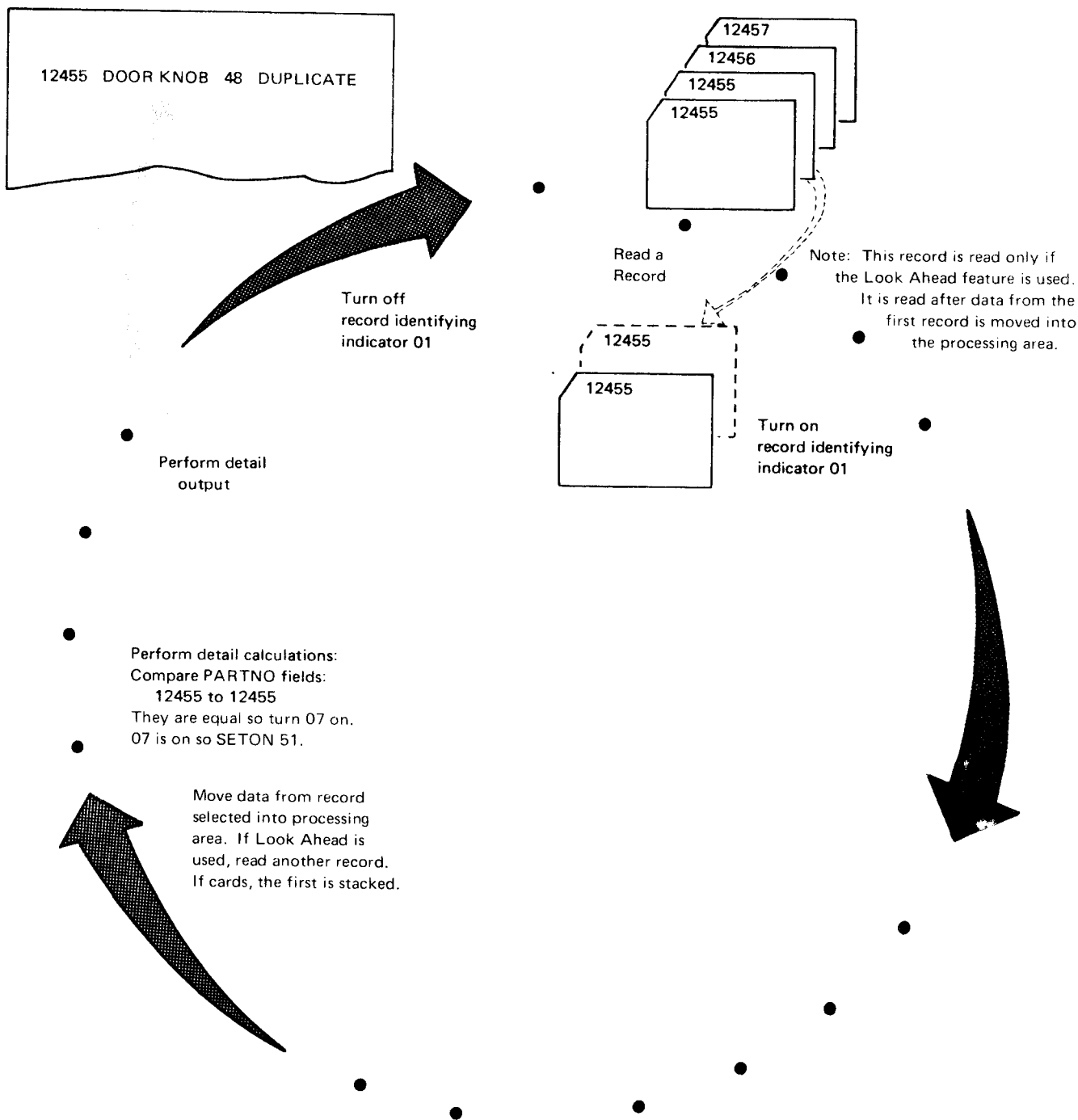

Figure 5-26 (Part 1 of 3). Logic for Look Ahead



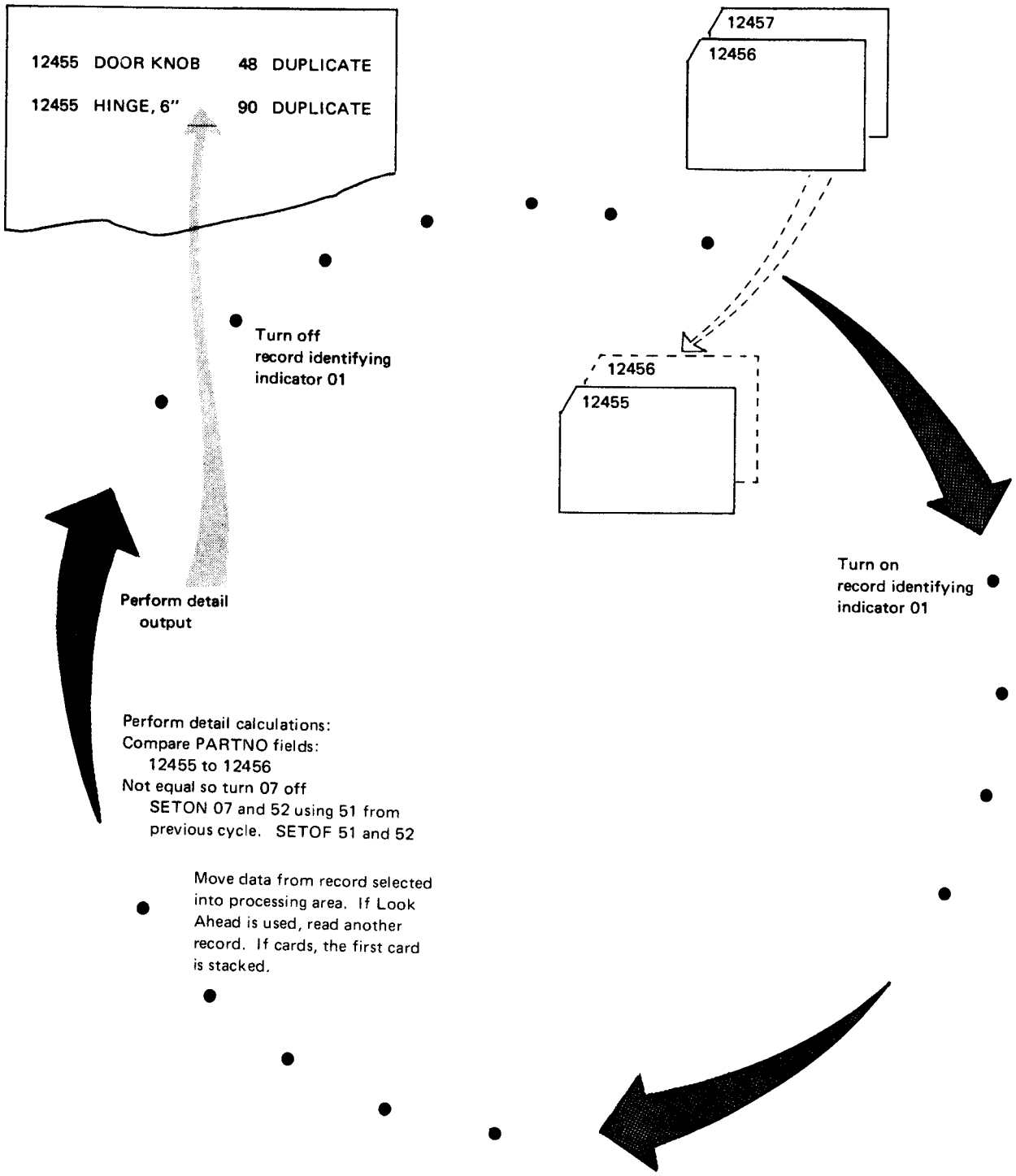
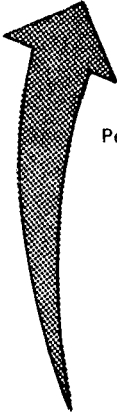
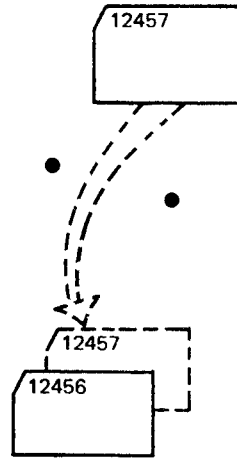

Figure 5-26 (Part 2 of 3). Logic for Look Ahead

12455	DOOR KNOB	48	DUPLICATE
12455	HINGE, 6"	90	DUPLICATE
12456	HINGE, 8"	75	

Turn off  
record identifying  
indicator 01



Perform detail  
output operations

Turn on  
record identifying  
indicator 01

Perform detail calculations:  
Compare PARTNO fields:  
12456 to 12457  
• Unequal so turn 07 off.

Move data from record selected  
into processing area. If Look  
Ahead is specified, read another  
record. If cards, the first card  
is stacked.

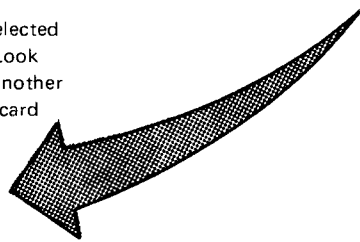

Figure 5-26 (Part 3 of 3). Logic for Look Ahead

## Doing Special Operations When There is Only One Record in a Group

It is often important to know if and when you are processing the only record in a group. The program described in the following paragraphs is such a case.

A report is prepared showing charges made by customers during the month (Figure 5-27). The input file is organized in ascending order by customer number. During the month some customers will have made one charge; others several.

When only one charge is made per customer, the total line is nearly a duplicate of the only detail line. In this case, you do not need to print both the detail and total line because the total line will do.

But how will you know during any one program cycle whether the current record is the only one in a group? You can find out by looking at information on the next record. Remember, any time information from the next record is necessary to determine how to process the current record, you must use the look ahead feature. Account number is established as a look ahead field in this program. Any look ahead field specified applies to all record types. Thus each record read contains information that will be looked at before the record itself is processed. By looking ahead into this field you will know whether or not the next record to be processed is part of a new group.

MONTHLY CHARGES			
ACCT NO	NAME	CHARGE	
47653	JILL ARNDT	4.97	} Detail lines
		5.99	
		23.87	
47653	JILL ARNDT	34.83 *	Total
49832	NANCY BENNET	87.93 *	Total
59821	JOAN BOND	7.42	Detail

Figure 5-27. Format of Monthly Charges Report

Whenever a record is read, the current ACCTNO field is compared to the one coming up. If the fields are equal, you know you are processing a record that is not the only one in a group. Therefore, a detail line should be printed. If the ACCTNO fields are not equal and this is the first time the present account number has been encountered, the current record is the only one in the group, and the detail line should not print. Figure 5-28 shows the specifications for the program.

IBM		RPG INPUT SPECIFICATIONS												GX21-9094 U/M 050*																							
International Business Machine Corporation														Printed in U.S.A.																							
Program												Punching Instruction		Graphic		Card Electro Number				Page 1 2 of		Program Identification 75 76 77 78 79 80															
Programmer												Date		Punch																							
Line	Form Type	Record Identification Codes												Field Location		Field Name	Control Level (L1-L9)	Matching Fields or Chaining Fields	Field Record Relation	Field Indicators																	
		1			2			3			From	To	Decimal Positions	Plus	Minus					Zero or Blank																	
		Sequence	Option (O)	Number (1-N)	Record Identifying Indicator	Position	Not (N)	C/Z/D	Character	Position	Not (N)	C/Z/D	Character	Position	Not (N)	C/Z/D	Character	Stacker Select	P/B/L/R																		
0 1	I	CHARGES	AA	01																																	
0 2	I																																				
0 3	I																																				
0 4	I																																				
0 5	I																																				
0 6	I																																				
0 7	I																																				
0 8	I																																				

Figure 5-28 (Part 1 of 2). Using Look Ahead to Determine When There is Only One Record in a Group

**IBM** International Business Machine Corporation

## RPG CALCULATION SPECIFICATIONS

Form GX21-9093  
Printed in U.S.A.

Program		Punching Instruction		Graphic		Card Electro Number		Page 1 2 of		Program Identification	
Programmer		Date		Punch							

Line	Form Type	Control Level (LD, LR, SR, AN, OR)	Indicators						Factor 1	Operation	Factor 2	Result Field		Resulting Indicators	Comments
			And	And	Not	Not	Not	Not				Name	Length		
01	C		DL					ACCTNO	COMP	NEXTNO			99		
02	C		99	DL					SETON				40		
03	C		DL					CHRG	ADD	TOTCHG	TOTCHG	62			
04	C	LL							SETOF				40		

**IBM** International Business Machine Corporation

## RPG OUTPUT SPECIFICATIONS

GX21-9090 U/M 050\*  
Printed in U.S.A.

Program		Punching Instruction		Graphic		Card Electro Number		Page 1 2 of		Program Identification	
Programmer		Date		Punch							

Line	Form Type	Filename	Type (H/D/T/E)	Space	Skip	Output Indicators						Field Name	End Position in Output Record	Constant or Edit Word
						And	And	Not	Not	Not	Not			
01	O	REPORT	H	3									55	'MONTHLY CHARGES'
02	O												25	'ACCT NO'
03	O												55	'NAME'
04	O												75	'CHARGE'
05	O													
06	O													
07	O		D	2										
08	O								LL		ACCTNO		25	
09	O								LL		NAME		65	
10	O										CHRG A		75	
11	O		T	13					LL					
12	O										ACCTNO		25	
13	O										NAME		65	
14	O										TOTCHGAB		75	
15	O												76	'*'

Figure 5-28 (Part 2 of 2). Using Look Ahead to Determine When There is Only One Record in a Group

## Doing Special Operations for the Last Record in a Group

In some programs, it may be necessary to do special operations on the last record of a control group. This is because, unless the last record in the control group is of a different type (have different record identification), it is impossible to know when you are processing the last record in the group. When all records are of the same type, you have to know what is on the next record before you know whether or not you are processing the last record in the group. To look at information in the next record, you must use the look ahead feature.

Figure 5-29 shows four records which are to be processed. The first three belong to one control group; the fourth is the beginning of the next group. The last record of the group (the third record in this case) requires special processing. In order to know when the last record in the group is to be processed, you must look at the account number in the next record. When it is different, you know that the last record in the group is being processed.

### Additional Points to Consider About Look Ahead

You must consider the following things when you are planning to use look ahead:

- When look ahead is used with a combined or update file, and that file is the only input file in the program, the field looked at is not on the next record, but on the record currently being processed. Therefore, there is little use for look ahead with update or combined files in a single file program. In a program with multiple input-type files, look ahead fields can be useful in update and combined files. For example, if two files with look ahead fields are being processed – an input file and a combined file (or update file) – look ahead fields in the combined file are available as the input file is being processed (see Figure 5-22).
- Look ahead is never used with chained, demand, or output files.
- Only one look ahead record type specification may be used for a file. There may be several fields listed under that one record type specification however.
- Any look ahead fields specified apply to all types of records in the file. Therefore, all records read from the file will be treated as if they have look ahead fields.

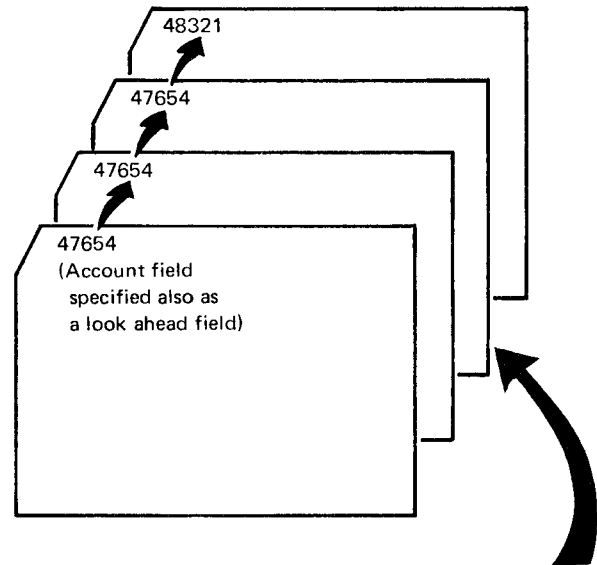

In the processing of this record, the Look Ahead feature shows that the next account number is different. Therefore, this is the last record of a group and as such requires special operations.

Figure 5-29. Using Look Ahead to Find Last Record in a Group

## MOVING DATA

You can instruct the program to manipulate data in many different ways. You can cause data to be added, subtracted, multiplied, compared, tested or divided. You can also cause data to be moved. When data is moved, a copy of the data in one field is transferred to another field. In the process of transfer, it may or may not be changed depending upon your specifications.

You may wish to move data for many reasons, including:

1. To save information from a field.
2. To separate one field into 2 or more parts.
3. To change a numeric field into an alphanumeric field or vice versa.

The preceding topics will be discussed later in this section. First, however, you must learn how to use the move operation codes.

## Specifications for Moving Data

Two operation codes can be used to move data: MOVE or MOVEL. For both operations Factor 2 and the Result Field are always used. Factor 2 may be either a field or constant. Any conditioning indicators may be used. However, Factor 1 and resulting indicators may not be specified.

The MOVE operation code moves a copy of characters starting from the rightmost position of Factor 2 into the rightmost positions of the Result Field. As a result of the move, the contents of the Result Field are changed, but the contents of Factor 2 remain the same. Figure 5-30 illustrates the MOVE operation.

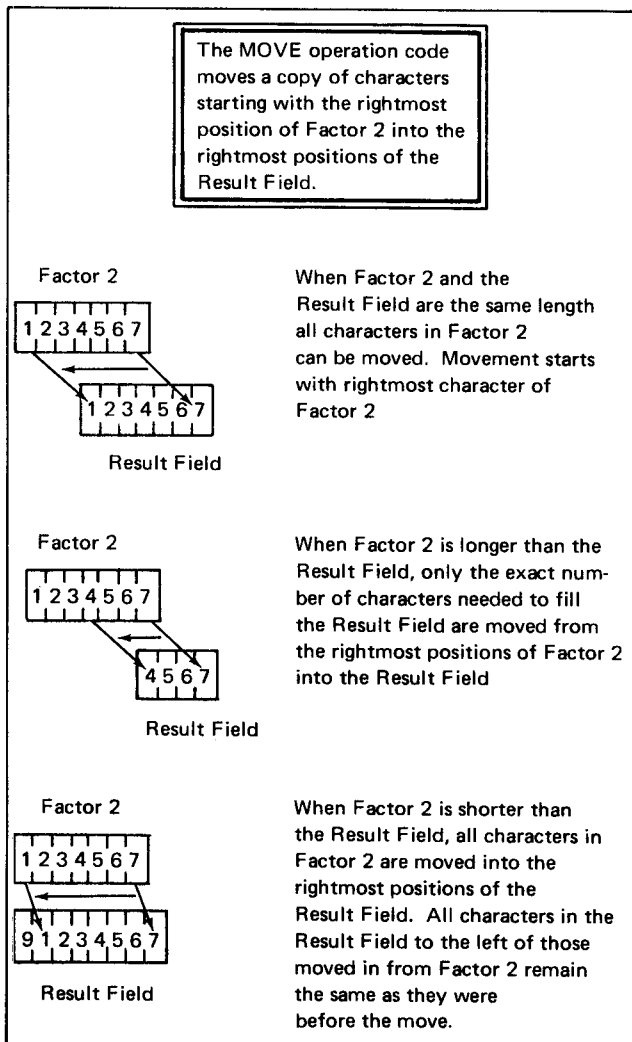

Figure 5-30. MOVE Operation Code

If the Result Field is the same length as Factor 2, all characters in Factor 2 are transferred. However, if the Result Field is shorter than Factor 2, only the number of characters needed to fill the Result Field are transferred. On the other hand, if the Result Field is longer than Factor 2, all characters in Factor 2 are moved to the rightmost positions of the Result Field. The excess leftmost characters of the Result Field remain unchanged.

The MOVEL operation is just the reverse of the MOVE operation; it moves a copy of the characters starting from the leftmost position of Factor 2 into the leftmost positions of the Result Field. Figure 5-31 illustrates the MOVEL operation.

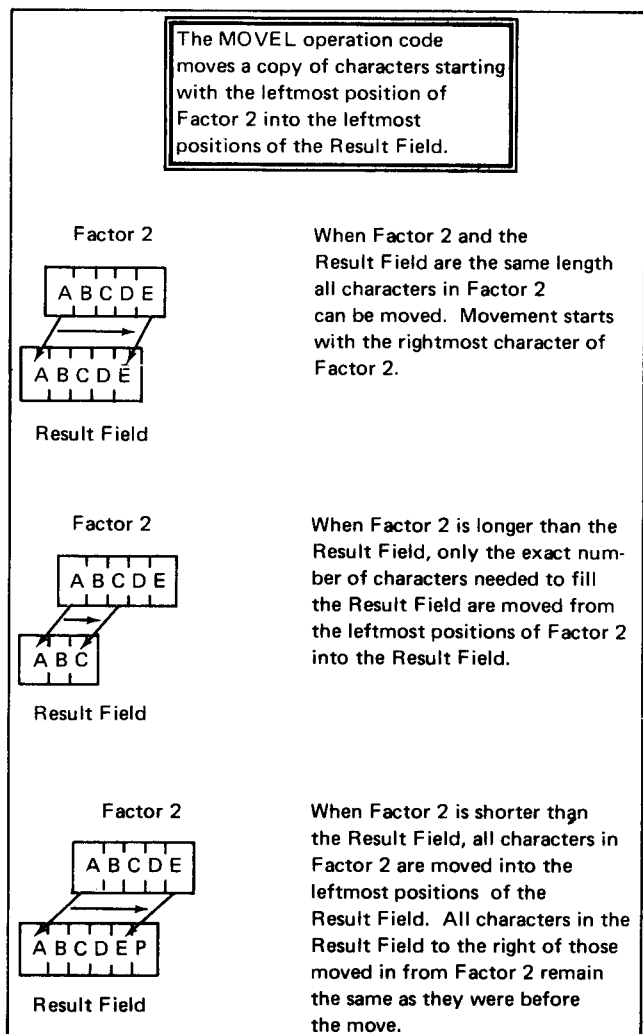

Figure 5-31. MOVEL Operation Code

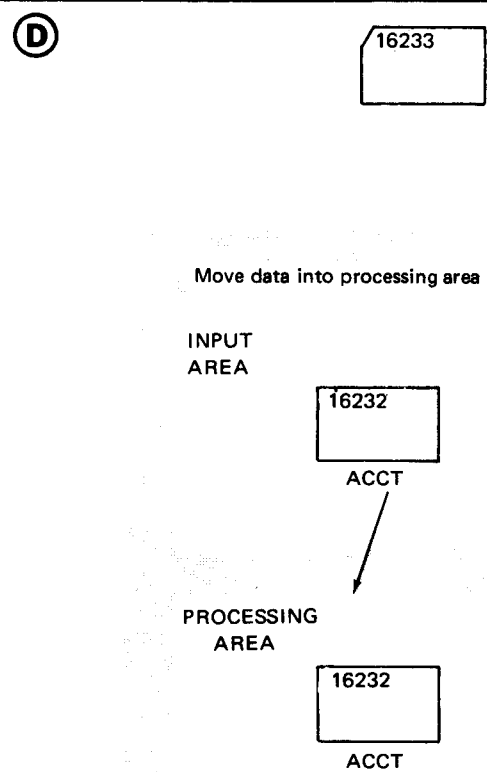
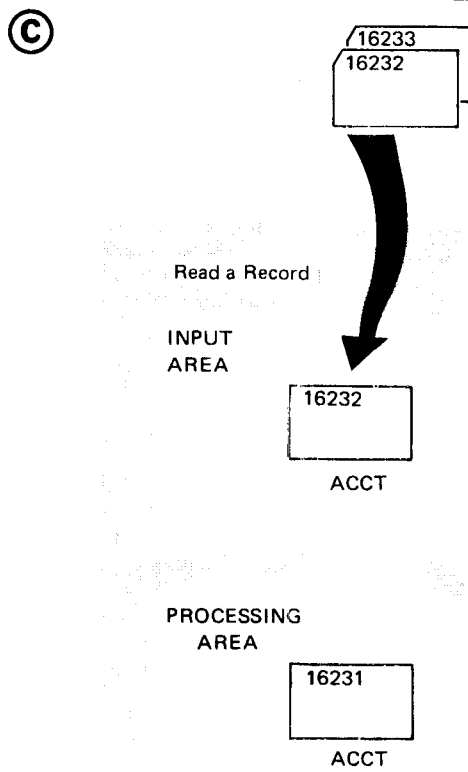
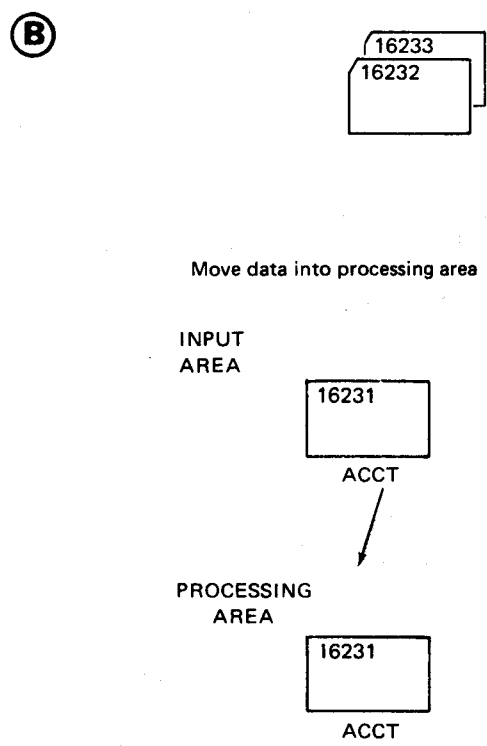
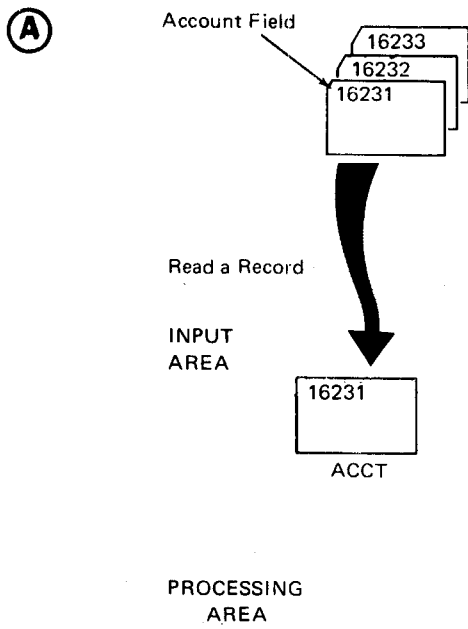

Figure 5-32. Data in Storage

### Saving Information From a Field by Move Operations

Any information in fields specified as input fields is normally only available for one program cycle. Each time a record is read, information from the fields on the new record replaces that which was there from the previous record (see Figure 5-32).

There are times, however, when you wish to save information from a record so that you can have it available in the next program cycle. For instance, you may want to check the contents of a field in order to determine if a file is in proper sequence or if it has duplicate entries. In order to do this, you must have the data from two fields, the field from the record just read and the field from the record read in the previous cycle.

Consider the problem of checking the sequence of, and finding duplicate entries for, the file shown in Figure 5-33. Sequence is to be based on ACCT (account number) and must be ascending. Any duplicate or out-of-sequence records are to be flagged.

The program must compare the ACCT fields from two records: the record currently being processed and the previous record. The current account field should always be higher than the previous account field. Would the specifications in Figure 5-34 do the job? They *would not*, because in one program cycle the field named ACCT always has the same information in it. This information is taken from the record just read. Just because you use the name twice, you won't get two different ACCT fields.

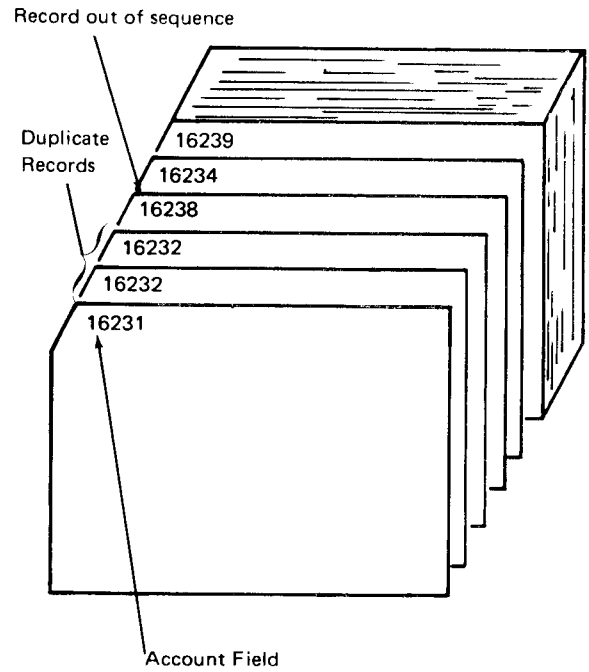

Figure 5-33. Input Field Sequence

C		Indicators		Factor 1		Operation		Factor 2		Result Field		Resulting Indicators		Comments	
Line	Form Type	And	And							Name	Length	Decimal Positions	Plus	Minus	Zero
3	4	5	6	7	8	9	10	11	12	13	14	15	16	17	18
01	C			ACCT		COMP	ACCT						9999		
02	C														
03	C														
04	C														
05	C														

Figure 5-34. Sequence Checking (Incomplete Specifications)



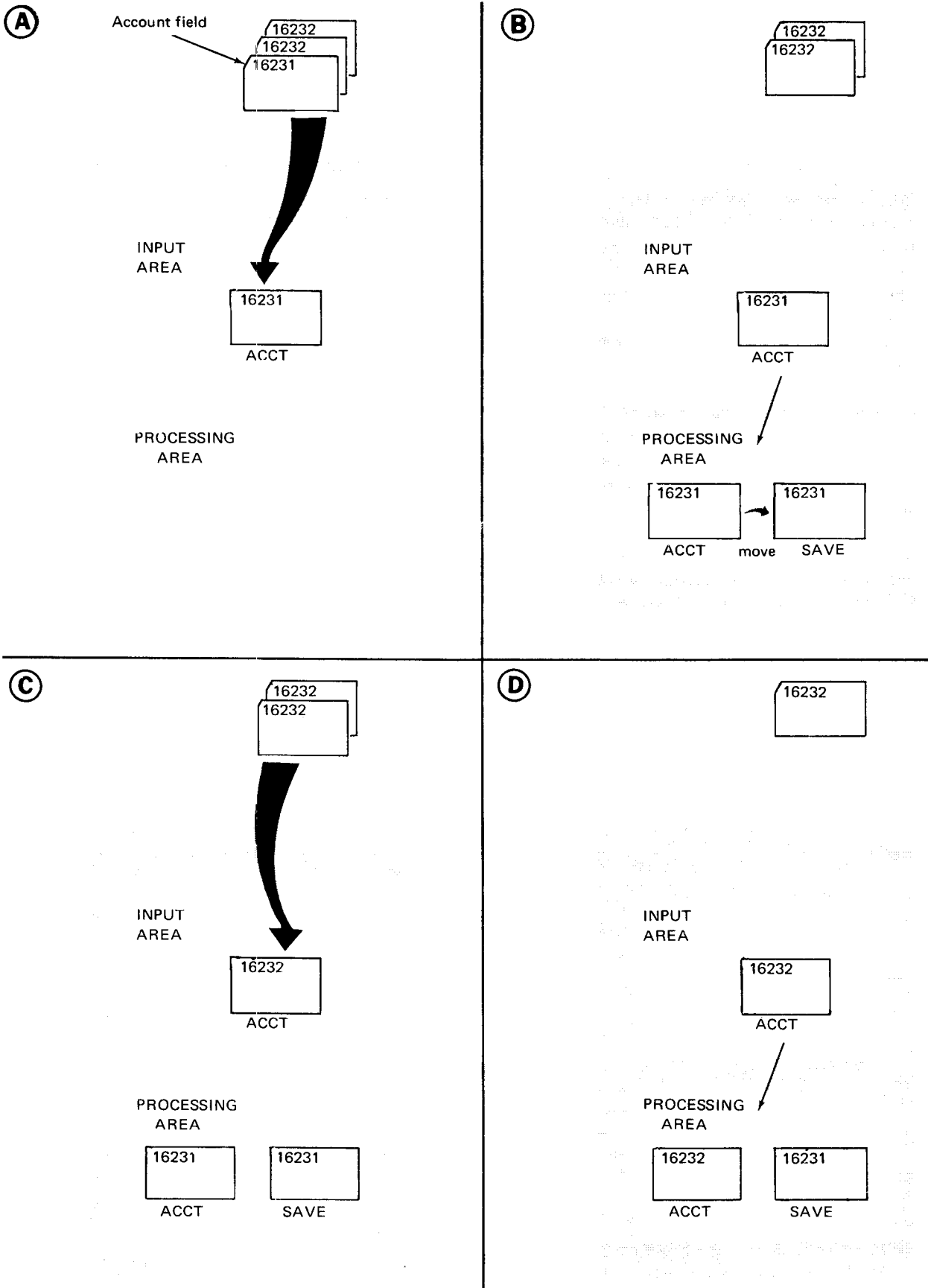

Figure 5-35. Moving Data to Save It

Therefore, each time a record is read, you must save the information from the ACCT field so that it is not destroyed when another record is read. This you can do by moving ACCT into another field. (Figure 5-35 illustrates this concept.)

Figure 5-36 shows the specifications needed to do the job. Assume that you move ACCT into a field called SAVE. The first step is to compare ACCT with SAVE (which contains the previous ACCT data). The second step is to move ACCT into SAVE. In the first program cycle, SAVE will contain all zeros since all numeric fields are set up with zeros before the first record is read. In the next cycle, and all cycles thereafter, SAVE will contain the ACCT field from the previous record.

Maybe you are wondering why you would ever want to sequence check by calculations instead of using the RPG II automatic sequence checking function which is done merely by specifying a match field. The answer is that, with RPG II automatic sequence checking, any out-of-sequence card will cause a *halt*. If you do not wish to halt, but merely wish to indicate out-of-sequence or duplicate cards, then you must do your own sequence checking. You could also use the look ahead feature, since both look ahead and the use of moves in calculations give essentially the same results.

### Separating One Field Into Two Parts

A company has designed its part numbers to contain two different kinds of information. The basic part number is contained in the first three characters. The remaining five characters contain the price. For example, in the part number 65J00498, the basic part number is 65J and the price is \$4.98. When preparing invoices, it is necessary to multiply unit price times quantity to find the total price. You don't

want to multiply the whole part number field times quantity just because the part of the field contains unit price. Somehow, you must separate price from the rest of the field.

To do this you again use a move operation. You cannot move the whole field into another field as was done in the previous example. This merely creates a second field identical to the first. You want only the last five characters. Therefore, you must move the field into a 5-position field. This will limit the move to five characters (see Figure 5-37).

RPG CALCULATION SPECIFICATIONS

Punching Instruction	Graphic									Card Electro Number
	Punch									

Operation	Factor 2	Result Field		Decimal Positions	Half Adjust (H)	Pic
		Name	Length			
MOVE	PARTNO	PRICE	5			

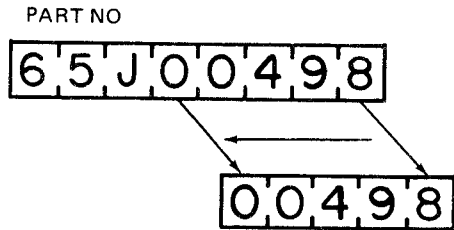

Figure 5-37. Separating the Price from the Part Number (Using MOVE)

IBM International Business Machine Corporation

RPG CALCULATION SPECIFICATIONS

Form GX21-9053 Printed in U.S.A.

Program	Programmer	Date	Punching Instruction	Graphic						Card Electro Number
			Punch							

Line	Form Type	Control Level (L, O, S, LR, SR, AN, D, BR)	Indicators			Factor 1	Operation	Factor 2	Result Field		Decimal Positions	Half Adjust (H)	Resulting Indicators	Comments
			And	And	And				Name	Length				
01	C					ACCT	COMP	SAVE					9999	
02	C						MOVE	ACCT	SAVE	5				

Figure 5-36. Sequence Checking (Correct Specifications)

In this case, the MOVE operation was used. Why wouldn't the MOVE operation work as well? Couldn't you move left into a 3-character field to separate the price from the rest of the part number? Remember that a move leaves the original field as it was before the move. MOVE does not remove the first three characters from the original PARTNO field. It merely copies them. You still would not have the unit cost by itself. But you would have the part number by itself (see Figure 5-38).

RPG CALCULATION SPECIFICATIONS							
anchoring instruction	Graphic	Card Electro Number					
	Punch						
Operation	Factor 2	Result Field					
		Name Length Decimal Positions					
		Half Adjust					
27	28 29 30 31 32	33 34 35 36 37 38 39 40 41 42	43 44 45 46 47 48	49 50 51	52	53	54
	MOVE PART NO	PART		3			

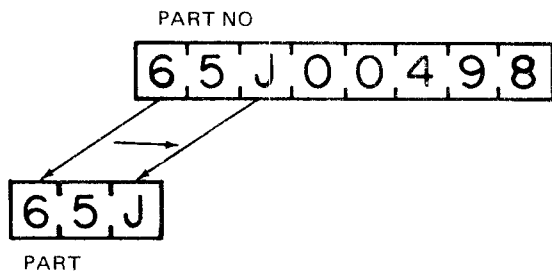

Figure 5-38. Separating the Part from the Part Number (Using MOVE)

### Changing Field Type (Alphanumeric or Numeric)

The part number field contains both numeric and alphabetic characters (see Figure 5-38). If you want the program to work with the zone portion of a character (as it must to get the letter J), you have to define the field as alphanumeric (blank in column 52 of the Input sheet). However, you cannot use an alphanumeric field in arithmetic calculations. To find total cost, you must multiply unit price by quantity. This is an arithmetic operation; thus the field must be numeric.

What do you do if you need one field to be defined as both alphanumeric and numeric? You could define the field twice—once as numeric and once as alphanumeric. Of course, you would have to use two names for the same field since every field defined for one type of record must have a unique name.

You may also use a move operation to change a numeric field into an alphanumeric field or vice versa. You can change fields by:

1. Moving an alphanumeric field named in Factor 2 into a numeric Result Field.
2. Moving a numeric field named in Factor 2 into an alphanumeric Result Field.

Figures 5-39 and 5-40 give the rules for and examples of the various types of moves you can make to change a field type. Figure 5-39 illustrates the MOVE operation and Figure 5-40 the MOVE operation. If you do not understand results obtained in the low order positions, see the chapter entitled *Working With Data Structures*.

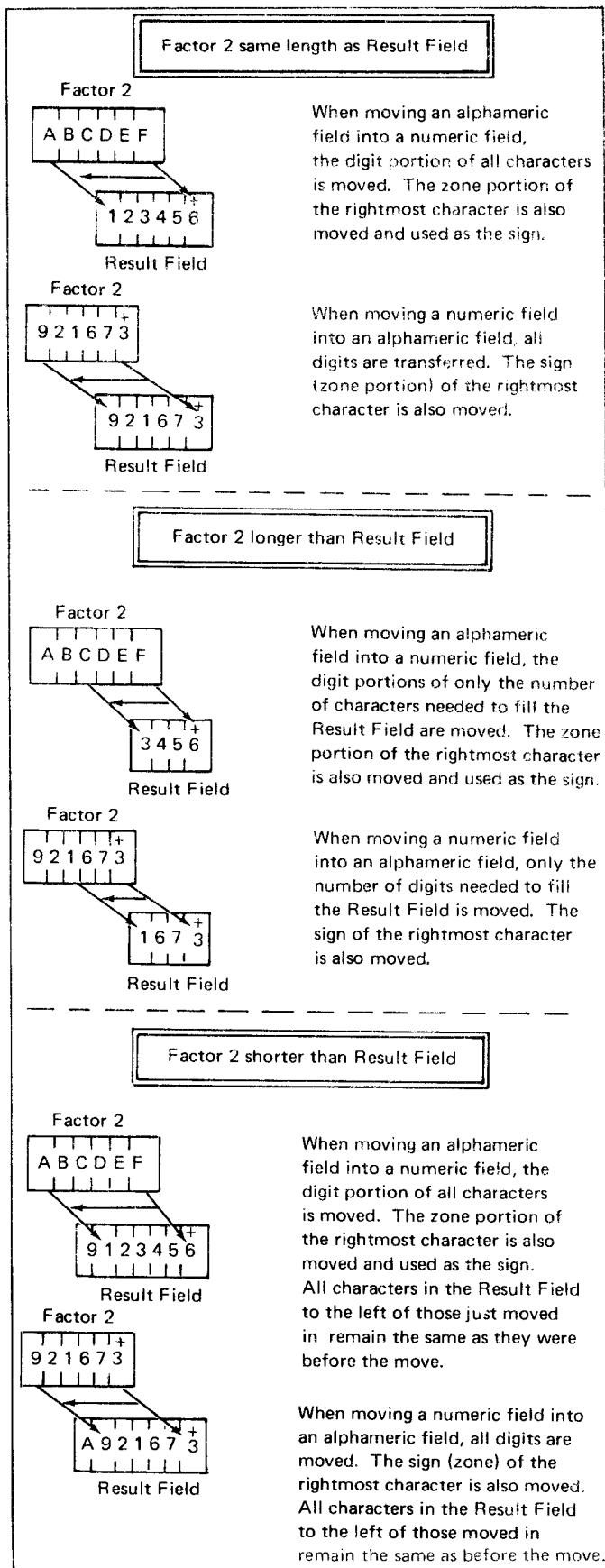

Figure 5.39. MOVE Operations Involving Fields of Various Lengths and Types

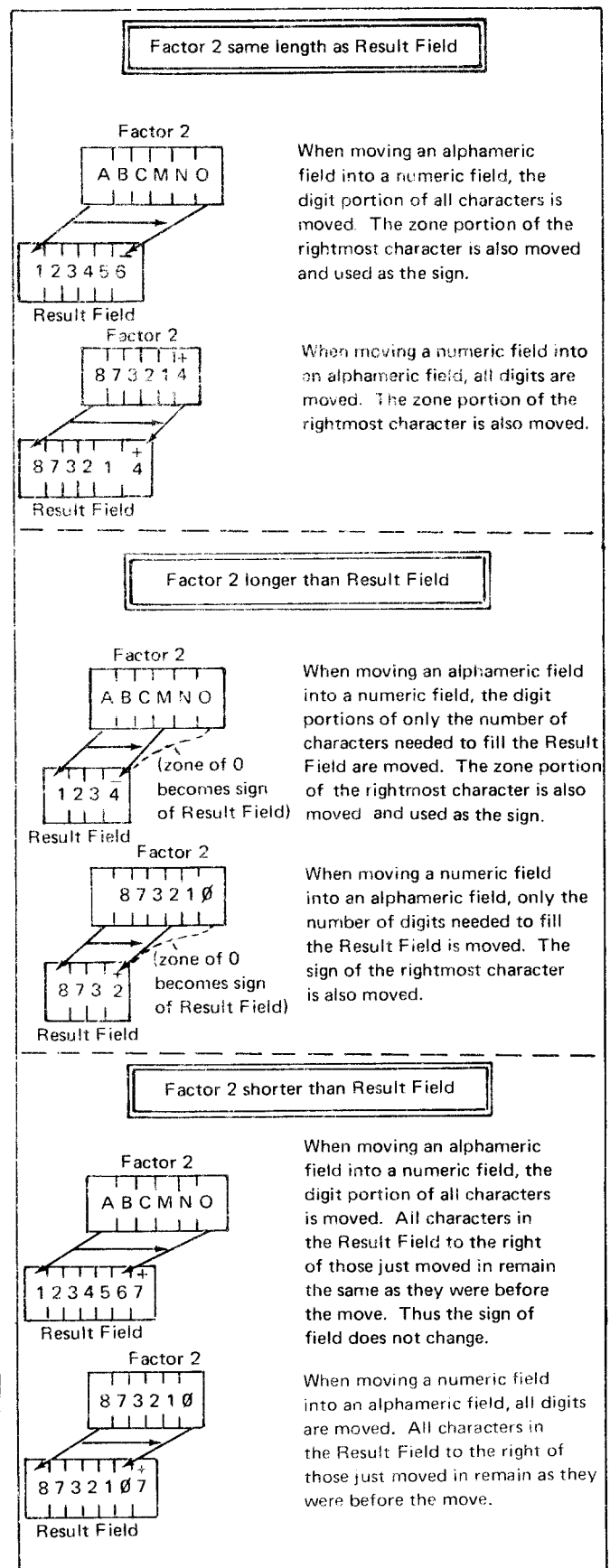

Figure 5.40. MOVE Operations Involving Fields of Various Lengths and Types

In order for the letter in the part number ever to be read, compared, or printed, the field must be defined as alphanumeric. When it is time to multiply price times quantity, the price portion of the field must be numeric. Therefore, when using the MOVE operation to separate the unit cost from the rest of the part number, you should, at the same time, change the alphanumeric unit price into a numeric unit price by moving it into a numeric field. To define a numeric field, you must specify decimal position along with field length (see Figure 5-41).

If the 5-character unit cost had preceded the part number (for example, 0049865J), you would then use the MOVE L operation to get the unit cost alone. Remember, however, that the zone of the rightmost character is used for the sign of the field (see Figure 5-40). The zone of the character J is a minus sign. The price will appear as negative. This you would not want.

The part number field is defined as alphanumeric since no entry has been made in column 52.

Field Location		Decimal Positions	Field Name	Control Level (1, 1, L, 9)												
From	To															
44	45	46	47	48	49	50	51	52	53	54	55	56	57	58	59	60

PG CALCULATION SPECIFICATIONS

The price section of the part number field is changed to a numeric field by moving it into a numeric field. Two decimal places were specified to show the cents portion of the field.

Operation	Factor 2	Result Field	
		Name	Length
28	29	30	31
32	33	34	35
36	37	38	39
40	41	42	43
44	45	46	47
48	49	50	51
			52

Figure 5-41. Changing a Field by the MOVE Operation

When using move operations to change an alphanumeric to a numeric field, keep in mind the kind of sign (plus or minus) each character will give you: a - (minus sign), or J through R gives a minus sign; the rest give a positive sign. If you are aware of this, you will not get unexpected results. Since no sign is involved in an alphanumeric field, you don't need to worry about the sign when changing a numeric to an alphanumeric field.

BRANCHING IN CALCULATIONS

The detail and total operations written on the Calculation sheet are normally executed in the same order as they are written. For each record selected for processing, the detail operations are performed sequentially from beginning to end. If the record selected for processing causes a control break, the total operations are performed, in the order specified, before detail operations.

There are many times, however, when it is necessary that operations not be performed sequentially. For example, in one cycle you may wish to skip some calculations or to do others several times. In this section you will learn to alter the sequential processing of calculations using the most efficient coding.

Bypassing Calculations

So far you have been bypassing operations by the use of indicators. For each calculation conditioned by indicators, a check is made to see if the condition set by the indicators is satisfied. (When several sequential operations are conditioned by the same indicator(s), the test is only made on the first operation.) If the condition is satisfied, the operation is performed. Calculations are bypassed or omitted when conditions are not satisfied. When bypassing calculations in this way, the program has to check the conditions set for the operations to determine whether or not to do them. This requires time and storage space inside the computer.

Another way to bypass calculations is to branch around them. With the latter method, the indicator setting for each operation is not checked. When the branch is taken around operations, the operations are just skipped (see Figure 5-42, insert A).

Two operation codes are used for branching: GOTO and TAG. GOTO is the code which causes a branch to another spot in the calculations. The TAG operation gives the name and location of the spot to which the GOTO operation branches. GOTO causes a branch; the TAG code does nothing but act as a nametag.

Figure 5-42, insert B, shows how GOTO and TAG are specified. GOTO signals a branch to the spot named in Factor 2. This name must also appear in the TAG statement, where it is entered in Factor 1. The rules for forming a name for GOTO and TAG are the same as those for forming any field name.

A GOTO statement can be conditioned by an indicator, but a TAG cannot. When a GOTO is not conditioned, a branch occurs in every program cycle.

In the example shown in Figure 5-42, the GOTO operation is done only when 01 is on. If the condition is satisfied, a branch is taken to that point in the program where the same

NEXT is found. NEXT is the name of the TAG statement. Any operations between the GOTO statement and the TAG statement (those specified in lines 03-05) are skipped. TAG does nothing, so the next operation performed is the SUB instruction in line 07.

If branching were not done, the three operations skipped by the branch would have to be conditioned by NO1 so that they would not be done when 01 turned on. And, of course, a check would have to be made in each program cycle to determine if the operations should be done or not.

There are many situations in which branching will help you write more efficient and effective programs. The following sections will explain more fully the use of GOTO and TAG.



C		Indicators		Factor 1	Operation	Factor 2	Result Field		Resulting Indicators	Comments
Line	Form Type	And	And				Name	Length		
01	C			BALNCE	ADD PURCHS	BALNCE	60			
02	C	01			GOTO NEXT					
03	C									
04	C									
05	C									
06	C			NEXT	TAG					
07	C			BALNCE	SUB PAYMNT	BALNCE				

Figure 5-42. Bypassing Calculations by Branching Around Them

### Branching When Different Record Types Require Different Operations

When doing different operations for different record types, you use the record identifying indicators to show what operations should be done for each record type read (see Figure 5-43). When you have several record types and each type requires several operations, you can see that many conditioning indicators are necessary.

For situations like this, you can branch directly to the set of calculations which should be done for the record type just read. When those calculations are done, you can then branch to the end of all calculations. This eliminates checking operations to see if a set of calculations should be done for the record type being processed. In fact, record identifying indicators do not need to be specified for the individual operations. Figure 5-44 shows the recommended branching structure used for different record types which require different operations. Using this structure not only makes your programs more efficient but also makes them easier to understand and document.

Consider the use of such a branching structure in a sales analysis program. Each day the manager of a retail store wishes to know total cash sales, total charge sales, and total refunds. The input file, arranged in ascending order by account number, contains four different record types:

1. Charge records record total charges and refunds (if any) for a particular account.
2. Payment records record any payments received. They are included in the file, but are not needed in this job.
3. Refund records record any refunds made for an account. No cash and charge sales were made by this customer.
4. Cash sales records record total cash sales and cash refunds (if any) for a particular account.

C		Indicators																	Factor 1		Operation	Factor 2		Result Field		Resulting Indicators			Comments	
Line	Form Type	Control Level (L, O, G, LR, SR, AN, OR)	Not	And	And	Not	Not	Not	Not	Not	Not	Not	Not	Not	Not	Not	Not	Not	Name	Length	Decimal Positions	Plus	Minus	Zero	Compare	High	Low	Equal		
01	C		01																RECEV	ADD	TOTREC	TOTREC	60							These operations are done on record type 01.
02	C		01																RECEV	ADD	FINREC	FINREC	70							
03	C		02																ADJCOD	COMP	'01'								These operations are done on record type 02.	
04	C		02																ADJCOD	COMP	'02'									
05	C		02	91															ADJUST	ADD	ADJHAN	ADJHAN	60							These operations are done on record type 02.
06	C		02	91															ADJUST	ADD	FINADJ	FINADJ	70							
07	C		02	92															ADJUST	ADD	TOTORD	TOTORD	60							This operation is done on record type 03.
08	C		03																ORDER	ADD	TOTORD	TOTORD								
09	C		04																ISSUE	ADD	TOTISS	TOTISS	60							These operations are done on record type 04.
10	C		04																ISSUE	ADD	FINISS	FINISS	70							
11	C		05																REQUIR	ADD	TOTREG	TOTREG								This operation is done on record type 05.
12	C		06																REQBAL	ADD	TOTREG	TOTREG								
13	C		06																ONCRD	ADD	TOTORD	TOTORD								These operations are done on record type 06.
14	C		06																ONHAND	ADD	FINOPN	FINOPN	70							
15	C		06																ONHAND	ADD	NEWHAN	NEWHAN	60							

Figure 5-43. Operations Performed for Different Record Types

RPG CALCULATION SPECIFICATIONS

Form GX21-9093  
Printed in U.S.A.

**IBM** International Business Machine Corporation

Program	Punching Instruction	Graphic	Card Electro Number
Programmer	Date	Punch	

Page 1 2 of Program Identification 75 76 77 78 79 80

Line	Form Type	Indicators						Factor 1	Operation	Factor 2	Result Field		Resulting Indicators			Comments
		Control Level (LD, LR, SR, AN, OR)	And	And	Not	Not	Not				Name	Length	Arithmetic	Plus	Minus	
01	C		01						GOTO	ROUT1						
02	C		02						GOTO	ROUT2						
03	C		03						GOTO	ROUT3						
04	C		04						GOTO	ROUT4						
05	C								GOTO	END						
06	C						ROUT1		TAG							
07	C								{							
08	C								}							
09	C															
10	C								GOTO	END						
11	C						ROUT2		TAG							
12	C								{							
13	C								}							
14	C								GOTO	END						
15	C						ROUT3		TAG							
16	C								{							
17	C								}							
18	C								GOTO	END						
19	C						ROUT4		TAG							
20	C								{							
	C						END		TAG							

Figure 5-44. Recommended Branching Structure



RPG INPUT SPECIFICATIONS

Program	Punching Instruction	Graphic	Card Electro Number
Programmer	Date	Punch	

Page 1 of 2 Program Identification 75 76 77 78 79 80

Line	Form Type	Filename	Sequence Number (1-N)	Record Identifying Indicator or Option (O)	Record Identification Codes									Field Location		Field Name	Control Level (1-L)	Matching Fields or Chaining Fields	Field Record Relation	Field Indicators		
					1	2	3	From	To	Plus	Minus	Zero or Blank										
01	I	DALYTRNSAB		01	95	CC	96	CH				1	8	ACCTNO								
02	I											10	162	CHARGE								
03	I											20	262	CHGREF				10				
04	I		AC	02	96	CP						1	8	ACCTNO								
05	I		AD	03	96	CR						10	162	PAYMNT								
06	I		AE	04	95	CC	96	CA				1	8	ACCTNO								
07	I											10	162	REFUND								
08	I											1	8	ACCTNO								
09	I											10	162	CASH								
10	I											20	262	CASHRF				11				

RPG CALCULATION SPECIFICATIONS

Program	Punching Instruction	Graphic	Card Electro Number
Programmer	Date	Punch	

Page 1 of 2 Program Identification 75 76 77 78 79 80

Line	Form Type	Control Level (L-L9, LR, SP, AN/ON)	Indicators			Factor 1	Operation	Factor 2	Result Field		Resulting Indicators	Comments
			And	And	And				Name	Length		
01	C		01									
02	C		02									
03	C		03									SKIP ALL FOR 02
04	C		04									
05	C				ROUT01	TAG						
06	C		10		CHARGE	SUB	CHGREF	CHARGE				SPECIFICATIONS FOR TYPE 01.
07	C				CHARGE	ADD	TOTCHG	TOTCHG	72			
08	C		10		CHGREF	ADD	TOTREF	TOTREF	72			
09	C											
10	C				ROUT03	TAG						
11	C				TOTREF	ADD	REFUND	TOTREF				SPECIFICATIONS FOR TYPE 03.
12	C											
13	C				ROUT04	TAG						
14	C		11		CASH	SUB	CSHREF	CASH				SPECIFICATIONS FOR TYPE 04.
15	C				CASH	ADD	TOTCSH	TOTCSH	72			
16	C		11		TOTREF	ADD	CSHREF	TOTREF				
17	C				END	TAG						

Figure 5-45. Sales Analysis Job



**Branching at Different Points in the Program**

Within one program you may use any number of GOTO and TAG operation codes. One or more GOTO statements may have the same name (Figure 5-45, insert B, lines 02, 09, and 12). However, each TAG must have a different name. If two TAGs had the same name, your program would not know where to branch.

**Branching at Detail and Total Time**

You may branch from one detail calculation to another detail calculation or from one total calculation to another total calculation. However, you cannot branch from a detail to a total calculation or vice versa.

**Branching Backward**

So far, you have learned only about branching forward in order to skip statements that you do not wish to perform. The GOTO statement can also branch backward. In this way you can go back to statements that were already done in order to do them again.

Doing the same statements over and over again in one program cycle is called *looping*. The statements done several times in one cycle, plus the branching statement, make up the *loop*. Figure 5-49 shows the basic structure of a loop.

When would you want to branch backward? Suppose you want to print out several mailing labels for each customer by using the EXCPT operation code (see *Repetitive Output (EXCPT Operation)* in the chapter, *Programmed Control of Input and Output* for an explanation of the EXCPT operation). EXCPT is used to write several output records in one program cycle. If you want to put out 25 mailing labels for Joe Aaron, you would have to write the EXCPT operation 25 times — one time for each record. However, instead of writing EXCPT 25 times, you could use a loop. One EXCPT code is specified. It is performed and then a backward branch is taken so that EXCPT will be done again.

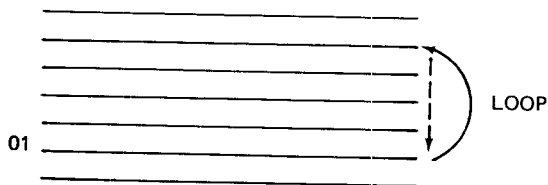

**Figure 5-49. Structure of a Loop**

Look at Figure 5-50. The loop just described is coded here. But look at what will happen: An EXCPT record will be printed; a backward branch will cause the EXCPT to be done again; then another branch, and another EXCPT. When would execution of the statements in the loop end? As coded here, execution of these statements would go on indefinitely.

You want to stop printing mailing labels for Joe Aaron after 25 have been made. Therefore, you have to keep track of the number printed. This is done through the use of a special count field which is constantly updated to reflect the number of times looping has occurred. Figure 5-51 shows the way this is done. At the beginning of each cycle, COUNT, the field used to keep track of the number of records printed, must be zero. Each time a record is put out, 1 is added to COUNT. COUNT is then compared to 25, the number of mailing labels desired. When COUNT equals 25, calculations will be complete for that program cycle, and looping will stop. When COUNT is less than 25 (indicator 10 is on), a branch is taken back to the beginning of the calculations so that they can be done again.

In this example, 25 mailing labels are created each cycle (for each record read). If a *different* number of records are required to be printed or punched for each cycle, you have to compare the COUNT field to another *field* which contains the number of records to be put out in that cycle (see Figure 5-52).

RPG CALCULATION SPECIFIC																																											
1655 Machine Corporation											Date		Punching Instruction		Graphic Punch																												
Indicators				Factor 1										Operation										Factor 2																			
And		Nor																																									
11	12	13	14	15	16	17	18	19	20	21	22	23	24	25	26	27	28	29	30	31	32	33	34	35	36	37	38	39	40	41	42	43	44										
							AGAIN										TAG										EXCPT																
																	GOTO										AGAIN																

**Figure 5-50. An Uncontrolled Loop**

RPG CALCULATION SPECIFICATIONS

Form GX21-9083  
Printed in U.S.A.

IBM International Business Machine Corporation

Program	Punching Instruction	Graphic	Card Electro Number
Programmer	Date	Punch	

Page 1 of 2  
Program Identification 75 76 77 78 79 80

Line	Form Type	Control Level (L0-L9, LR, SR, AN/OR)	Indicators			Factor 1	Operation	Factor 2	Result Field		Resulting Indicators	Comments
			And	And	Not				Name	Length		
01	C					COUNT	SUB	COUNT	COUNT	20		
02	C					AGAIN	TAG					
03	C						EXCPT					
04	C					1	ADD	COUNT	COUNT			
05	C					COUNT	COMP	25			10	
06	C		10				GOTO	AGAIN				
07	C											

Figure 5-51. A Controlled Loop

RPG CALCULATION SPECIFICATIONS

Form GX21-9083  
Printed in U.S.A.

IBM International Business Machine Corporation

Program	Punching Instruction	Graphic	Card Electro Number
Programmer	Date	Punch	

Page 1 of 2  
Program Identification 75 76 77 78 79 80

Line	Form Type	Control Level (L0-L9, LR, SR, AN/OR)	Indicators			Factor 1	Operation	Factor 2	Result Field		Resulting Indicators	Comments
			And	And	Not				Name	Length		
01	C					COUNT	SUB	COUNT	COUNT	20		
02	C					AGAIN	TAG					
03	C						EXCPT					
04	C					1	ADD	COUNT	COUNT			
05	C					COUNT	COMP	NEED			10	NUMBER IN NEED
06	C		10				GOTO	AGAIN				FIELD MAY VARY
07	C											

Figure 5-52. Printing a Various Number of Records in Each Cycle

You can have as many loops in your program as you need. You can even have one loop within another loop (see Figure 5-53, insert A).

Keep in mind, however, that an uncontrolled loop is an endless loop. Each loop you create must be controlled so that it will be performed only a limited number of times. Always set up a condition which when satisfied will cause looping to stop (see Figure 5-53, insert B).

### USING SUBROUTINES IN CALCULATIONS

A routine is something done over and over again. The calculations in your program can be called a routine because the operations are done again and again (on each program

cycle). A *subroutine* is a routine that is part of another routine. That is, a subroutine is a group of operations that can be used by the main routine several times in the same program cycle. A subroutine can also be a sequence of operations that is coded once and included in several different programs.

Subroutines can be used to:

- Eliminate duplicate coding by performing the same calculations several times in the same program cycle or in several different programs.
- Reduce the storage requirements of RPG II programs (see *Controlling Overlay by Using Subroutines* in this chapter).

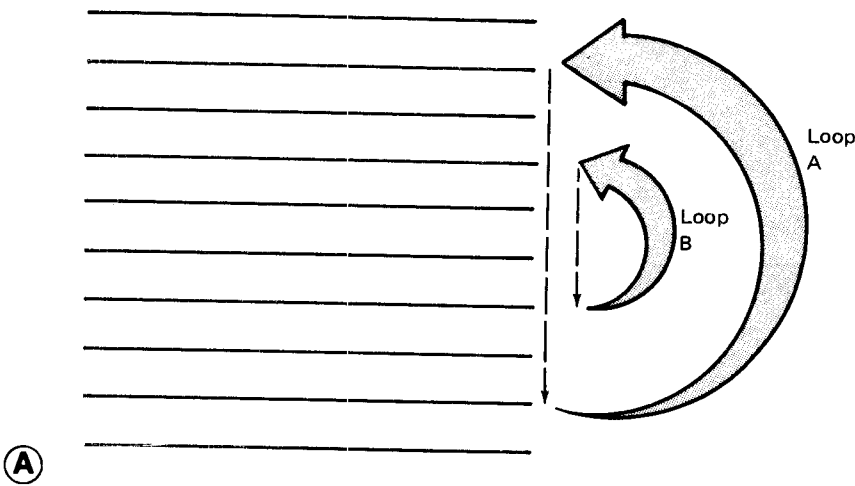

C		Indicators		Factor 1		Operation		Factor 2	
Line	Form Type	And	And						
3	4	5	6	7	8	9	10	11	12
0 1	C								
0 2	C			LOOPA			TAG		
0 3	C								
0 4	C			LOOPB			TAG		
0 5	C								
0 6	C								
0 7	C	II					GOTO LOOPB		
0 8	C								
0 9	C	II					GOTO LOOPA		
1 0	C								
1 1	C								

**B** The backward branches will be done only when conditions are satisfied.

Figure 5-53. A Loop Within a Loop

**Using Subroutines to do the Same Calculations Several Times in One Cycle**

In many of your programs, the same operation(s) may be required several times in one cycle: When coding the job, you can specify the operations as many times as needed. This often involves large amounts of coding, however. If the same operations are to be done several times in succession, you can often use looping to reduce the amount of coding. This was explained in the previous section.

What if the same operations are not done several times in succession, but are performed, instead, at many different points in your program? Creating a loop couldn't work in this case. As an example, consider the job which creates a weekly sales commission report. The report desired (Figure 5-54) shows two things:

1. Total commission earned by each salesman.
2. Total commissions paid in each district.

The area in which all salesmen work is divided into three districts: A, B, and C. Some salesmen work in only one district. Others may work in parts of two or more districts.

For each salesman, the input file contains a record formatted as shown in Figure 5-55. The amounts in the district fields show total weekly sales made by that salesman in each district. If the salesman did not work a district or made no sales in that district, the field contains a zero.

The report must contain the commission earned in each district by each salesman. In addition, total commission must be accumulated for each salesman and for each district. The percentage of commission is:

- 3 percent of the gross sales .01 to 1000.00 dollars.
- Plus 2 percent of the gross sales 1000.01 to 5000.00 dollars.
- Plus 1 percent of the gross over 5000.00 dollars.

COMMISSION REPORT				
Salesman	Dist A	Dist B	Dist C	Total
Joe Arness	41.93	23.16	9.43	74.52 ← ①
Bob Brown		113.16	24.93	138.09
Charles Butler	26.98	449.16	109.38	585.52
	1,998.02 *	986.43 *	1,043.97 * ← ②	

Figure 5-54. Sales Commission Report

SALESMAN	DIST A	DIST B	DIST C	
1 2 3 4 5 6 7 8 9 10 11 12 13 14 15 16 17 18 19 20 21 22 23 24 25	26 27 28 29 30 31 32	33 34 35 36 37 38 39	40 41 42 43 44 45 46	47 48 49 50 51 52 53 54 55 56 57 58 59 60

Figure 5-55. Input Record for Sales Commission Report

Figure 5-56 shows the calculations needed to find the information required for the report. You first compare the contents of each district field to zero to find out if the salesman sold anything in that district. If it is not zero, you calculate the commission (COMM) earned. You then add commission earned to total commission for the salesman (MANTOT) and to total commission paid in each district (TOTALA, TOTALB, or TOTALC).

The calculations needed to find commission earned are the same for each district (Figure 5-56, inserts A, B, C, lines 3-16). Why code these calculations three times? Why not code them once and branch to them each time they are needed? (See Figure 5-57.)

Using the branching you have learned about so far, the branching that uses GOTO and TAG, you could easily branch to the calculations needed to find commission. But since you could branch to them from *three* different places, it would be difficult to determine to which point in the calculations you should return. You could return to the point where totals are accumulated for district A, the point they are accumulated for district B, or the point they are accumulated for district C. Imagine the number of indicators and SETON and SETOF operations necessary to do this. Wouldn't it be nice if the program would automatically go back to the point from which it branched?

RPG II can do this through the use of a subroutine. Your entire program is the main routine. The operations to be performed several times in the program cycle make up a subroutine. In this case, the main program uses the subroutine to find commission earned.

C		Indicators		Factor 1	Operation	Factor 2	Result Field		Resulting Indicators			Comments	
Line	Form Type Control Level (L, O, L, B, or LP, SR, AN/OR)	And	And				Name	Length	Decimal Positions Half Adjust (H)	Arithmetic	Plus		Minus
01	C			DISTA	COMP	0							
02	C	99			GOTO	B							
03	C			DISTA	COMP	1000.00							
04	C	L0		DISTA	MULT	.03	COMMA	62H					
05	C	L0			GOTO	TOTALA							
06	C			DISTA	COMP	5000.00							
07	C	L1		DISTA	SUB	1000.00	OVER	62					
08	C	L1		OVER	MULT	.02	COMMA	H					
09	C	L1		30.00	ADD	COMMA	COMMA						
10	C	L1			GOTO	TOTALA							
11	C	L2		DISTA	SUB	5000.00	OVER						
12	C	L2		OVER	MULT	.01	COMMA	H					
13	C	L2		110.00	ADD	COMMA	COMMA						
14	C			TOTALA	TAG								
15	C			COMMA	ADD	MANTOT	MANTOT	62					
16	C			COMMA	ADD	TOTALA	TOTALA	72					
17	C			B	TAG								

Calculations required to find commission earned.

Figure 5-56 (Part 1 of 2). Calculations for Sales Commission Program

RPG CALCULATION SPECIFICATIONS

Form GX21-9093  
Printed in U.S.A.

IBM International Business Machine Corporation

Program \_\_\_\_\_ Punching Instruction \_\_\_\_\_ Graphic \_\_\_\_\_ Card Electro Number \_\_\_\_\_  
 Programmer \_\_\_\_\_ Date \_\_\_\_\_ Punched \_\_\_\_\_ Punch \_\_\_\_\_

Page 1 2 of \_\_\_\_\_ Program Identification 75 76 77 78 79 80

Line	Form Type	Control Level (LD,LR,LR,SR,AN/OR)	Indicators			Factor 1	Operation	Factor 2	Result Field		Resulting Indicators	Comments
			And	And	And				Name	Length		
01	C					DISTB	COMP 0				99	
02	C		99				GOTO C					
03	C					DISTB	COMP 1000.00				1010	
04	C		10			DISTB	MULT .03	COMMB	62H			
05	C		10				GOTO TOTALB					
06	C					DISTB	COMP 5000.00				1211111	
07	C		11			DISTB	SUB 1000.00	OVER				
08	C		11			OVER	MULT .02	COMMB	H			Calculations required to find commission earned.
09	C		11			30.00	ADD COMMB	COMMB				
10	C		11				GOTO TOTALB					
11	C		12			DISTB	SUB 5000.00	OVER				
12	C		12			OVER	MULT .01	COMMB	H			
13	C		12			110.00	ADD COMMB	COMMB				
14	C					TOTALB	TAG					
15	C					COMMB	ADD MANTOT	MANTOT	62			
16	C					COMMB	ADD TOTALB	TOTALB	72			
17	C					C	TAG					

RPG CALCULATION SPECIFICATIONS

Form GX21-9093  
Printed in U.S.A.

IBM International Business Machine Corporation

Program \_\_\_\_\_ Punching Instruction \_\_\_\_\_ Graphic \_\_\_\_\_ Card Electro Number \_\_\_\_\_  
 Programmer \_\_\_\_\_ Date \_\_\_\_\_ Punched \_\_\_\_\_ Punch \_\_\_\_\_

Page 1 2 of \_\_\_\_\_ Program Identification 75 76 77 78 79 80

Line	Form Type	Control Level (LD,LR,LR,SR,AN/OR)	Indicators			Factor 1	Operation	Factor 2	Result Field		Resulting Indicators	Comments
			And	And	And				Name	Length		
01	C					DISTC	COMP 0				99	
02	C		99				GOTO END					
03	C					DISTC	COMP 1000.00				1010	
04	C		10			DISTC	MULT .03	COMM	62H			
05	C		10				GOTO TOTALC					
06	C					DISTC	COMP 5000.00				1211111	
07	C		11			DISTC	SUB 1000.00	OVER				
08	C		11			OVER	MULT .02	COMMC	H			Calculations required to find commission earned.
09	C		11			30.00	ADD COMMC	COMMC				
10	C		11				GOTO TOTALC					
11	C		12			DISTC	SUB 5000.00	OVER				
12	C		12			OVER	MULT .01	COMMC	H			
13	C		12			110.00	ADD COMMC	COMMC				
14	C					TOTALC	TAG					
15	C					COMMC	ADD MANTOT	MANTOT	62			
16	C					COMMC	ADD TOTALC	TOTALC	72			
17	C					END	TAG					

Figure 5-56 (Part 2 of 2). Calculations for Sales Commission Program



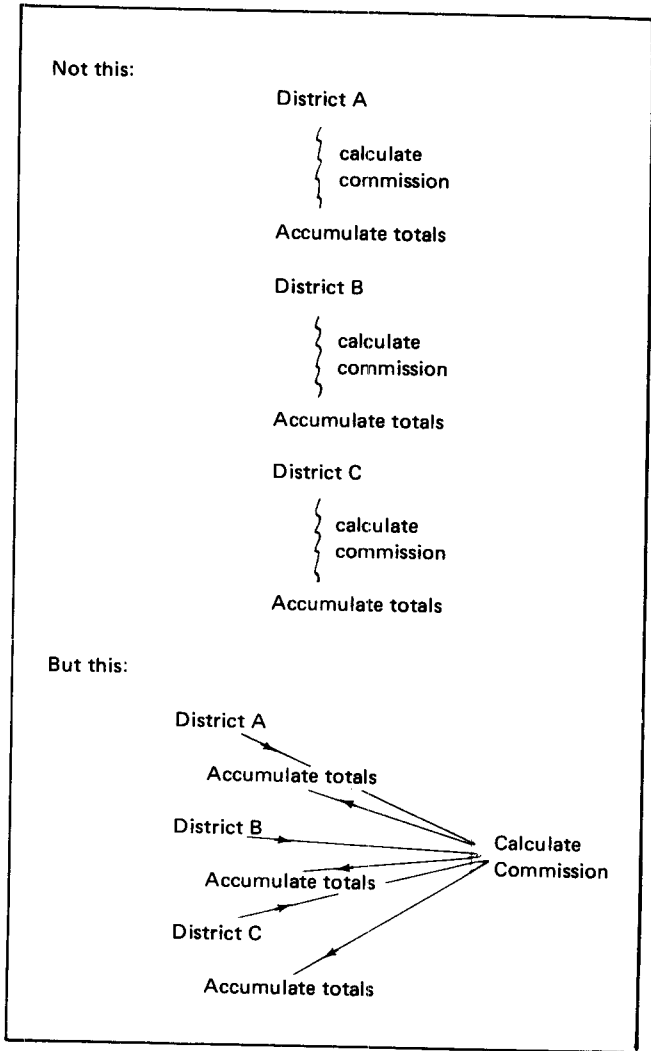

Figure 5-57. Branching to Similar Calculations

### Specifications for Coding a Subroutine

Subroutines are specified on the Calculation sheet after all detail and total operations. Every statement in the subroutine must be identified as part of the subroutine by the letters SR in columns 7-8. (See Figure 5-58.) In addition, two operation codes, BEGSR and ENDSR, are needed to establish the beginning and end of the subroutine.

Every subroutine used in the program must have a unique name. The rules for forming a subroutine name are the same as those for forming a field name. The name must appear in Factor 1 on the same line as the BEGSR operation code.

RPG CALCULATOR

IBM International Business Machine Corporation

Program		Punching Instruction		Graphic	
Programmer		Date		Punch	

Line	Form Type	Control Level (LD, L3, LR, SR, AN, OR)	Indicators			Factor 1	Operation	Factor 2
			And	And	Not			
0 1	C							
0 2	C							
0 3	C							
0 4	C							
0 5	C							
0 6	C							
0 7	C	SR			SUB	BEGSR		
0 8	C	SR						
0 9	C	SR						
1 0	C	SR						
1 1	C	SR						
1 2	C	SR				ENDSR		
1 3	C							

Figure 5-58. Structure of a Subroutine

### Calling the Subroutine

When using GOTO and TAG, you use a GOTO operation code to branch to the next operation to be performed. When you do the operations in a subroutine, you do not branch to the subroutine; you *call* it.

When you call a subroutine, you use the execute subroutine (EXSR) operation code. This operation code can be placed anywhere in the calculation operations. Whenever the EXSR operation code is encountered, all operations in the subroutine will be performed. After the subroutine has been executed, RPG II branches back to the main program and continues execution with the next statement after the EXSR statement (Figure 5-59).

Factor 2 must contain the name of the subroutine to be executed. This same name must appear on a BEGSR instruction.



### RPG CALCULATION SPECIFICATIONS

Program	Punching Instruct	Graphic	Card Electro Number	Page <span style="border: 1px solid black; padding: 0 5px;">1</span> of <span style="border: 1px solid black; padding: 0 5px;">2</span>
Programmer	Date	Punch		Program Identification <span style="border: 1px solid black; padding: 0 5px;">75</span> <span style="border: 1px solid black; padding: 0 5px;">76</span> <span style="border: 1px solid black; padding: 0 5px;">77</span> <span style="border: 1px solid black; padding: 0 5px;">78</span> <span style="border: 1px solid black; padding: 0 5px;">79</span> <span style="border: 1px solid black; padding: 0 5px;">80</span>

C	Line	Form Type 7 8	Indicators						Factor 1	Operation	Factor 2	Result Field		Decimal Positions S: Half Adjust (H)	Resulting Indicators			Comments
			And		And		Name	Length				Arithmetic	Plus		Minus	Zero		
			9	10	11	12						13	14		15	16	17	
	0 1	C								DIS TA		COMP 0					99	
	0 2	C										GOTO B						
	0 3	C										Z-ADD DISTA		SALES		72		
	0 4	C										EXSR SALSUB						
	0 5	C								COMM		ADD MANTOT		MANTOT		62		
	0 6	C								COMM		ADD TOTALA		TOTALA		72		
	0 7	C										Z-ADD COMM		COMMA		62		
	0 8	C								B		TAG						
	0 9	C								DIST B		COMP 0						
	1 0	C										GOTO C						98
	1 1	C										Z-ADD DISTB		SALES				
	1 2	C										EXSR SALSUB						
	1 3	C								COMM		ADD MANTOT		MANTOT				
	1 4	C								COMM		ADD TOTALB		TOTALB		72		
	1 5	C										Z-ADD COMM		COMMB		62		
	1 6	C								C		TAG						
	1 7	C								DIST C		COMP 0						
	1 8	C										GOTO END						97
	1 9	C										Z-ADD DISTC		SALES				
(B)		C										EXSR SALSUB						

Figure 5-60 (Part 2 of 4). Sales Commission Program (Using a Subroutine)

*Using Subroutines in the Sales Commission Report Example*

Now that you have learned how subroutines are used, defined, and executed, see how they are used in the sales commission report program. All specifications are shown in Figure 5-60.

First a record is read. Now commission earned in each district must be calculated.

1. DISTA is compared to zero to see if the salesman sold anything in that district. If the field is greater than zero, commission must be calculated. If the field is zero, a branch is taken to B, where another comparison is made.
2. Before the subroutine can be called, it must be supplied with the correct amount of sales. Thus, the contents of DISTA are moved into SALES.

3. The subroutine is called by the EXSR operation code.
4. The commission is calculated by operations specified in the subroutine.
5. The subroutine is finished when ENDSR statement is executed. The instruction following EXSR is executed. The commission found by the subroutine is added to the total commission earned by the salesman (MANTOT) and to the total commission paid in the district (TOTALA).
6. Now DISTB is compared to zero to see if commission earned should be calculated. If so, information from the field DISTB is moved to SALES, and the subroutine is called. The next steps are basically the same as those already described. Follow the rest of the program.

RPG CALCULATION SPECIFICATIONS

Form GX21-9093  
Printed in U.S.A.

IBM International Business Machine Corporation

Program	Punching Instruction	Graphic	Card Electro Number
Programmer	Date	Punch	

Page 1 of 2  
Program Identification 75 76 77 78 79 80

Line	Form Type	Control Level (L0 L1, L2, L3, SR, AN/OR)	Indicators			Factor 1	Operation	Factor 2	Result Field		Resulting Indicators	Comments				
			And	And	Not				Name	Length			Arithmetic	Plus	Minus	Zero
01	C					COMM	ADD	MANTOT	MANTOT							
02	C					COMM	ADD	TOTALC	TOTALC	72						
03	C						Z-ADD	COMM	COMM	62						
04	C					END	TAG									
05	SR					SALESUB	BEGSR									
06	SR					SALES	COMP	1000.00			1010					
07	SR	10				SALES	MULT	.03	COMM	62H						
08	SR	10					GOTO	FINISH								
09	SR					SALES	COMP	5000.00			1211111					
10	SR	11				SALES	SUB	1000.00	OVER	62						
11	SR	11				OVER	MULT	.02	COMM	H						
12	SR	11				30.00	ADD	COMM	COMM							
13	SR	11					GOTO	FINISH								
14	SR	12				SALES	SUB	5000.00	OVER							
15	SR	12				OVER	MULT	.01	COMM	H						
16	SR	12				110.00	ADD	COMM	COMM							
17	SR					FINISH	ENDSR									
18	C															
19	C															
20	C															
	C															
	C															
	C															
	C															
	C															

Figure 5-60 (Part 3 of 4). Sales Commission Program (Using a Subroutine)

Program	Punching Instruction	Graphic	Card Electro Number
Programmer	Date	Punch	

Page 1 2 of Program Identification 75 76 77 78 79 80

Line	Form Type	Filename	Type IND/TEL			Space		Skip		Output Indicators			Field Name	End Position in Output Record	Constant or Edit Word
			O	R	A	N	D	Before	After	Before	After	And			
01	O	REPORT	H								LP				
02	O													68	'COMMISSION REPORT'
03	O		H								LP				
04	O		OR								OV				
05	O														
06	O													35	'SALESMAN'
07	O													55	'DIST A'
08	O													65	'DIST B'
09	O													75	'DIST C'
10	O													LL0	'TOTAL'
11	O		D								OL				
12	O													45	NAME
13	O													55	COMMA LB
14	O													65	COMMB LB
15	O													75	COMMC LB
16	O													LL0	MANTOTLB
17	O		T								LR				
18	O													55	TOTALA
19	O													56	'*'
20	O													65	TOTALB
	O													66	'*'
	O													75	TOTALC
	O													76	'*'

Figure 5-60 (Part 4 of 4). Sales Commission Program (Using a Subroutine)

Using Valid Subroutine Operations

Any operation code that can be used in calculations can be used in a subroutine except BEGSR and ENDSR. This means that you can use all arithmetic, compare and testing, move look-up, EXSR, and branching operations.

There are limitations on some of the operations:

1. You may only branch to another statement *in the subroutine* when using the GOTO statement (Figure 5-61, insert A).
2. You may branch to the ENDSR statement if you put a name in Factor 1 of the ENDSR statement.

3. You may not branch to a statement outside of the subroutine (Figure 5-61, insert B).
4. You cannot branch to a TAG within the subroutine from a GOTO outside of the subroutine (Figure 5-61, insert C).
5. You cannot have a subroutine coded within another subroutine. However, one subroutine can call another subroutine. This means that within one subroutine you may have an EXSR statement (Figure 5-62). A subroutine, however, cannot call itself and cannot call the subroutine which called it.

Line	Form Type	Control Level	Indicators						Factor 1	Operator	Exit
			And	And	And	And	And	And			
0											
0.5	C										
0.6	C										
0.7	C										
0.8	C										
0.9	C										
1.0	C										
1.1	C	SR						SUBA	BEGSR		
1.2	C	SR									
1.3	C	SR	01						GOTO END		
1.4	C	SR									
1.5	C	SR						END	ENDSR		

(A)

Line	Form Type	Control Level	Indicators						Factor 1	Operator	Exit
			And	And	And	And	And	And			
0											
0.6	C										
0.7	C										
0.8	C										
0.9	C										
1.0	C										
1.1	C	SR									
1.2	C	SR									
1.3	C	SR									
1.4	C	SR									
1.5	C	SR									
1.6	C	SR									

(B)

Line	Form Type	Control Level	Indicators						Factor 1	Operator	Exit
			And	And	And	And	And	And			
0.6	C										
0.7	C										
0.8	C										
0.9	C										
1.0	C										
1.1	C	SR									
1.2	C	SR									
1.3	C	SR									
1.4	C	SR									
1.5	C	SR									
1.6	C	SR									

(C)

Figure 5-61. Branching Within a Subroutine

IBM		RPG CALCULAT																																																	
Program		Punching Instruction														Graphic																																			
Programmer		Date														Punch																																			
Line	Form Type	Indicators												Factor 1	Operation	Fac																																			
		Control Level (LD, LB, LR, SR, AN, OR)				And		And		Not		Not																																							
3	4	5	6	7	8	9	10	11	12	13	14	15	16	17	18	19	20	21	22	23	24	25	26	27	28	29	30	31	32	33	34	35	36																		
DO THIS: Use one subroutine to call another subroutine																																																			
0 4	C																																																		
0 5	C																																																		
0 6	C																																																		
0 7	C	SR																																																	
0 8	C	SR																																																	
0 9	C	SR																																																	
1 0	C	SR																																																	
1 1	C	SR																																																	
1 2	C	SR																																																	
1 3	C	SR																																																	
1 4	C	SR																																																	
1 5	C	SR																																																	
1 6	C	SR																																																	
1 7	C	SR																																																	
1 8	C																																																		

Conditioning Subroutine Statements

Any indicator which is valid in columns 9-17 can be used to condition an operation within the subroutine. That operation will then be performed only when the conditions established by the indicators are satisfied. The BEGSR and ENDSR operation code, however, cannot be conditioned by any indicators.

The EXSR statement can also be conditioned by indicators. In this case, the *entire* subroutine will be performed only when conditions for the EXSR statement are met. For example, in Figure 5-63, insert A, the subroutine will be performed only if MR is on.

Control level indicators cannot be used to condition statements within a subroutine since SR must appear in columns 7-8. The indicators used on the EXSR statement determine whether the *entire* subroutine is performed at detail time or at total time (Figure 5-63, insert B).

RPG II LINKAGE EDITOR

The output of the RPG II compiler becomes input to the linkage editor, which builds the load (object) module for later execution. The module can be cataloged into the library, punched into cards, or written to diskette.

The linkage editor combines the translated RPG II source code with the system library modules necessary to complete the program. The map of the linkage editor's output is printed following the compiler diagnostic messages (if present). The map also indicates the amount of internal storage used by portions of a program.

The RPG II compiler used on Models 4, 6, 8, 10, or 12 includes its own linkage editor, called the RPG II Linkage Editor. On Model 15, the RPG II compiler uses the overlay linkage editor that is part of the SCP. The following refers to the RPG II Linkage Editor, although conceptually, it is identical to the overlay linkage editor.

IBM		RPG CALCULAT																																																					
Program		Punching Instruction														Graphic																																							
Programmer		Date														Punch																																							
Line	Form Type	Indicators												Factor 1	Operation	Fac																																							
		Control Level (LD, LB, LR, SR, AN, OR)				And		And		Not		Not																																											
3	4	5	6	7	8	9	10	11	12	13	14	15	16	17	18	19	20	21	22	23	24	25	26	27	28	29	30	31	32	33	34	35	36																						
NOT THIS: Code a subroutine within another subroutine																																																							
0 4	C																																																						
0 5	C																																																						
0 6	C																																																						
0 7	C	SR																																																					
0 8	C	SR																																																					
0 9	C	SR																																																					
1 0	C	SR																																																					
1 1	C	SR																																																					
1 2	C	SR																																																					
1 3	C	SR																																																					
1 4	C	SR																																																					
1 5	C																																																						

Figure 5-62. Using EXSR Within a Subroutine

IBM		RPG CALCULATION SPECIFICATIONS															Form GC21-9093 Printed in U.S.A.			
Program		Punching Instruction					Graphic					Card Electro Number					Page 1 2 of		Program Identification 75 76 77 78 79 80	
Programme		Date					Punch													
Line	Code	Control Level (LO LG LR SR AM/OR)	Indicators						Factor 1	Operation	Factor 2	Result Field		Resulting Indicators			Comments			
			And	And	Not	Not	Not	Name				Length	Decimal Positions	Plus	Minus	Zero				
01	C																			
02	C		MR						EXSR	SUBA									SUBA will be executed at detail time if MR is on.	
03	C																			
04	C																			
05	C																			
06	C		LL						EXSR	SUBB									SUBA will be executed at total time.	
07	C																			

Figure 5-63. Conditioning Calculations Within a Subroutine

### Linkage Editor Map

Figure 5-63.1 illustrates the information available on the RPG II Linkage Editor map.

The *Start Addr* column gives the physical location in storage of each module. Figure 5-63.1 shows the modules in ascending sequence by address (which may not always be the case). The root section indicates the beginning of the program just after the system supervisor (0E00, in this case). The root section is 1,000 hexadecimal bytes long (see *Code Length* column); therefore, the next available location is 1E00. Note that the next higher address in the example is 1E00 for the input mainline section.

Start Addr	Name if Overlay	Code Length	Name	Title
0E00		1000	RGROOT	Root
1E00		0100	RGMAIN	Input Mainline
1F00		0100	RGSUBS	Record ID
2000		0050	RGSUBS	Input ctrl rtn
2050		0010	RGSUBS	Subseg
2060		0020	\$\$CSIP	5444 consec input
2080		0080	RGMAIN	Input fields
2100		0050	RGMAIN	Detail calcs
2150		0100	\$\$PGLC	Lokup routine
2250		0200	RGMAIN	Detail output
2450		0B00	RGSUBS	Constants

Figure 5-63.1. Linkage Editor Map

The *Code Length* column gives the storage requirements in hexadecimal. The *Name* column gives the name of system (and user) modules and designates the compiler-created segments (which begin with RG). The functions of modules are described, where practical, in the title column.

The root section contains I/O buffers, constants, and variables required to run RPG II programs. Subseg is a section that has functions that are not easily describable by the compiler. For example, a calculation subroutine is called a subseg.

The RGMAIN sections are the basic RPG II functions, such as input, detail calculations, total output, and so on. RGSUBS designates functions within the RGMAIN functions. The modules are listed in functional sequence; the subsections follow the main function. In Figure 5-63.1, the lokup routine follows the detail calcs section because a table look-up was performed in detail calculations. Similarly, the constants section, because it follows the detail output section, was defined on the output specifications for detail (or heading) lines.



**Simple Overlays**

An overlay structure begins if the load (object) module built by the linkage editor is larger than the available main storage in a machine (the size is specified on the H-card or is assumed to be that of the machine used for compilation). The linkage editor begins with low-usage modules such as execution time table dump and load routines, file open and close, LR calculations and output, and so on. It allocates an overlay fetch area large enough to hold the largest of the selected routines (or groups of routines) and calls for an overlay fetch routine, which will load into that overlay area the selected routines as they are needed. The overlay fetch routine checks to see if a requested overlay is already in the overlay area before going to the disk library to load it. This action saves time by avoiding unnecessary loads from disk.

With overlays, the root section occupies the lowest position in storage as before. It is followed by the overlay fetch routine. The overlay fetch area comes next, followed by the secondary root routine, or root 2. Root 2 is made up of those routines that do not have to be overlaid.

All the overlaid routines are given names in the *Name If Overlay* column. The names are \$###nnn, where nnn is a three-digit overlay number.

Figure 5-63.2 shows a storage map of a program and Figure 5-63.3 shows a library map of the same program. Figure 5-63.4 is a diagram that illustrates the maps shown in Figures 5-63.1 and 5-63.2. The library map indicates the overlay size in the # *Text Sectors* column. You can see in Figure 5-63.3 that overlay #2 (\$###002) is the largest, occupying seven sectors; this is equivalent to 0700 bytes in hexadecimal (all storage requirements will be stated in four hexadecimal digits). The storage map shows the overlay fetch area of 0700 bytes. It also indicates that overlay #2 contains the total calculations and is actually only 0630 bytes long (0600 for total calcs, 0020 for constants, and 0010 for exception output). Therefore, overlay #2 occupies seven sectors: six are full and the seventh has only 0030 bytes of code in it. If the user wants to reduce the size of the program's overlay area, he would first try to reduce the size of total calculations.

Start Addr	Name if Overlay	Code Length	Name	Title
0E00		1000	RGROOT	Root
1E00		0100	RGSUBS	Overlay fetch routine
1F00		0700	RGSUBS	Overlay fetch area
2600		0100	RGMAIN	Input mainline
2700		0100	RGMAIN	Input fields
1F00	###001	0200	RGMAIN	Detail calcs
2100	###001	00A0	RGSUBS	Constants
1F00	###002	0600	RGMAIN	Total calcs
2500	###002	0020	RGSUBS	Constants
2520	###002	0010	RGSUBS	Exception

Figure 5-63.2. Storage Map

Overlay Name	Relative Start C/T/S	#Text Sectors	Start Address
###001	00 00 16	03	1F00
###002	00 01 02	07	1F00
###003	00 01 0A	06	1F00
###004	00 01 11	04	1F00

Figure 5-63.3. Library Map

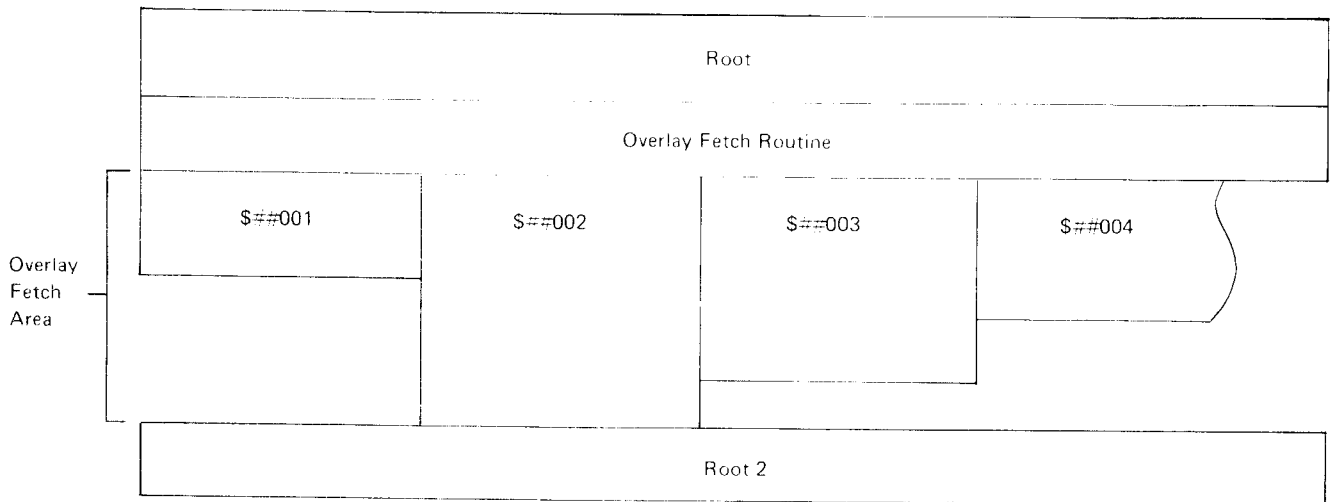

Figure 5-63.4. Diagram of Linkage Editor Map and Storage Map

The *Relative Start C/T/S* column gives relative library locations in cylinder, track, and sector for the overlays. This information does not pertain to this discussion.

### Special Open

Sometimes a storage map will not list an overlay #1 but will have other overlays starting with \$##002. This indicates that the special open has been implemented. The user cannot directly cause this to happen. The linkage editor provides this feature when it reduces a program's storage requirements. Special open does not affect throughput.

When the open/close overlay is the largest one, special open is implemented, rather than having that code increase the storage required for the rest of the program. Special open causes some of the unoverlaid code in root 2 to overlay the open routine after the files have been opened; it overlays some of root 2 with close at end-of-job.

### Overlay Starting Addresses

As the maps in Figure 5-63.5 show, there are two starting addresses for overlays. The main starting address for the illustration is 1F00. The starting address for the suboverlay is always higher; in this case, it is 2300.

### Storage Map

Start Addr	Name if Overlay	Code Length	Name	Title
1F00	\$##002	0200	RGMAIN	Detail calcs
2100	\$##002	0100	RGSUBS	Transfer vector
2200	\$##002	0002	RGSUBS	Contants
2300	\$##003	0100	\$\$PGRI	Reset Resulting indr
2400	\$##003	0100	RGSUBS	Subseg
2300	\$##004	0300	RGSUBS	Exception

### Library Map

Overlay Name	Relative Start C/T/S	#Text Sectors	Start Address
\$##001		07	1F00
\$##002		04	1F00
\$##003		02	2300
\$##004		03	2300
\$##005		03	1F00
\$##006		04	2300
\$##007		02	2300

Figure 5-63.5. Storage and Library Maps

\$\$\$002 is a main overlay with suboverlays. There are two indications of this: first, it includes a module RGSUBS (which is titled transfer vector), and second, it is followed on the maps by overlays with higher starting addresses.

The size of the overlay fetch area is the larger of (1) the largest overlay with suboverlays plus the largest suboverlay, or (2) the largest overlay without suboverlays. In Figure 5-63.5, the size of the overlay fetch area is equal to the sum of the sizes of \$\$\$002 and \$\$\$006. This is not obvious from the maps, but the block diagram (Figure 5-63.6) drawn from the maps makes this clear. Overlay 2 is the largest main overlay with suboverlays, so it determines the starting address for all suboverlays. Overlay 6 is the largest suboverlay. Together, overlays 2 and 6 require 8 sectors or 0800 bytes, which is greater than the 7 sectors (or 0700 bytes) for overlay 1.

If a user wants to reduce the size of the overlay fetch area, he could reduce the size of either \$\$\$002 or \$\$\$006. One sector, however, is all the user can expect to save because \$\$\$001 is just one sector smaller than the overlay fetch area.

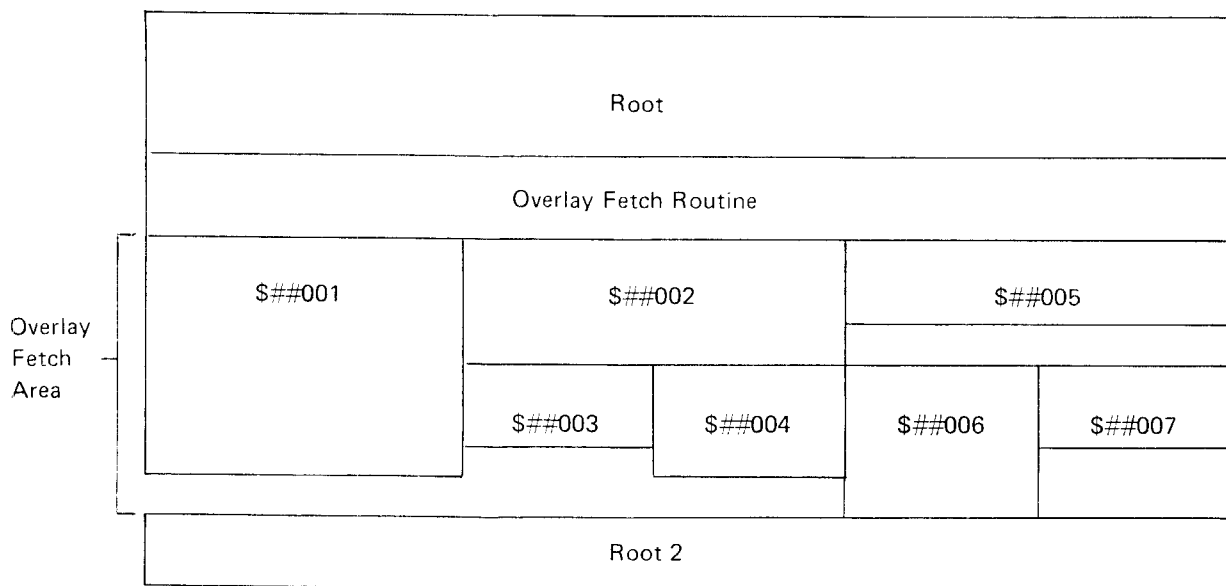

Figure 5-63.6. Diagram of Storage and Library Maps

### Fitting Available Storage

The linkage editor removes modules from root 2, placing them into the overlay structure until the program fits into available storage (or until there are no more modules to overlay, which means the program is too large to fit). After a fit is obtained, there may be unused space in storage. If there is, an attempt is made to find small modules that can be removed from the overlay structure and placed back into that free space.

This process of moving overlaid modules back into main storage might give you a *missing overlay*, that is, a suboverlay without a main overlay. In the storage map, you can sometimes notice unoverlaid modules among the overlays. This is a result of moving modules from main storage to an overlay and back again.

The linkage editor moves code rather than allowing available storage go unused. Having code moved back to main storage can improve speed of execution, but is not under the control of the user. The linkage editor moves the code when it can.

### RPG II Logic and Function Shifting

The basic functional areas of RPG II logic are summarized in the following sequence:

1. Detail Output—Detail and heading output (except for overflow lines) are performed.
2. Physical Input—Records are read from primary and secondary files, as necessary, and the ID indicator is set.
3. Total Calculations—All calculations with L and a number in columns 7 and 8 are performed. This includes all exception output specifications if EXCPT is performed, or all required input specifications for READs or CHAINs performed, or any user subroutines called with EXSR.
4. Total Output—Total output (except for overflow lines) is performed. You should note that total calculations and output are attempted on every cycle.
5. Overflow Output—All output lines with overflow indicators conditioning them are performed.
6. Logical Input—Data read in Step 2 is moved to the fields named on the input sheet, and the corresponding field indicators are set.
7. Detail Calculations—All calculations without L and a number in columns 7 and 8 are performed. See Step 3 for more information.

These functional areas can be identified by the titles of routines in the storage map. A user can reduce the size of any of these areas by one of three methods:

- Removing function from the program
- Using more efficient coding
- Shifting function from one general area to another

The removal of function from a program often results in a second program being written to perform those functions. Some system designs include luxuries that are not essential to the job. These functions may be removed from the program.

Functions that cannot be removed can often be moved to another area. Some total calculations can be moved easily to detail calculations.

The following multiply statement could be moved to detail calculations by conditioning it with the 01 indicator, just like the add, and deleting the L1 indicator on the MULT statement. The results will be identical. Similarly, some calculations can be moved from detail to total; however, a new record ID indicator will be on so the user may have to use an extra indicator.

C	01	AMT	ADD	TOTAL	TOTAL
CL1		TOTAL	MULT	RATE	DISCNT

Primary and secondary input are done at input time. READ and CHAIN are performed during calculations. If calculations are too big, a file processed with the CHAIN operation code might be first sorted and then matched as a secondary file against the primary. If input is too big, a secondary file could be made a demand file and processed with the READ operation code during calculations.

Output, like calculations, can be shifted between detail and total calculations. Even overflow output can be moved to the following detail or total calculations by using a numeric indicator, which is SETON conditioned by the overflow indicator. EXCPT is output performed during calculations. Some output functions may be moved from output to calculations (either detail or total).

Any calculation overlay or suboverlay that does an EXCPT will contain all E output specifications. If a suboverlay has EXCPT in it and is too large, that operation can usually be moved to another subroutine. If the subroutines are large, they can usually be divided into several smaller subroutines.

Calculation sections cannot be divided by the linkage editor to be separate overlays; subroutines can. They will become suboverlays to the main detail or total calculations overlay. If one subroutine calls another subroutine, both will appear in the same suboverlay. To divide them up, the first subroutine must return to regular calculations from which the second subroutine can be called.

Using shared I/O for disk files can save a great deal of space in some programs. With the resulting smaller overlay structure, performance may be improved. Alternatively, larger disk file buffers and double buffering could be specified. These two techniques use extra storage (resulting in more overlays) but may still perform faster because of the speed improvement in disk operations they provide. Selection between larger disk I/O buffers or shared buffers must be made by trial for each program.

Information about the overlay linkage editor can be found in the *IBM System/3 Overlay Linkage Editor Reference Manual*, GC21-7561.

## SPECIAL USES OF CONTROL LEVEL INDICATORS

At this time, you should be familiar with the normal use of control level indicators, L1-L9. You know that by assigning them on the Input sheet and using them on the Calculation and Output Specifications sheets you can do total operations.

In this section, you will learn to work with a special internal control level indicator L0. You will also learn to use L1-L9 indicators to condition calculations and to perform group printing.

### Internal Control Level Indicator L0

L0 is a unique control level indicator which is always on. You cannot assign it to a field, as you do L1-L9, by entering it in columns 59-60 of the Input sheet. But, you can use it to condition a calculation or output operation. The operation so conditioned will be done at total time for every program cycle, since L0 is always on.

The main purpose of the L0 indicator is to allow you to specify total operations when indicators L1-L9 are not available or when they cannot accomplish the job.

Suppose you want to print the report shown in Figure 5-64. The report is a listing of items a company has sold in each of its two districts. The report includes total sales for each district (DISTOT) and a grand total of sales in both districts (GDTOT). The input records are grouped by district with District 1 records preceding District 2. Each record contains an item number field (ITEM), an item description (DESCR), and an item cost field (COST), as shown in Figure 5-65.

A record identification code in position 1 indicates in which district the item was sold. Normally, the field containing the record identification code could be used as a control field in the printing of district totals. However, each district has more than one record identification code. District

1 uses either a 1 or an M as an identifier and District 2 uses either a 2 or an N. Since the contents of the record identification field can change without actually having a change in district, this field cannot be used as a control field. Neither, of course, can the ITEM, DESCR, or COST fields be used as control fields.

#### Artificial Control Breaks

When it is necessary to do total operations but no control fields are available to cause a control break, you can use L0 to cause an artificial control break. Figure 5-66, insert B, shows the use of L0 to permit total calculation operations.

34J261	PORTABLE COMPRESSOR	623.21	
46F419	PORTABLE GENERATOR, 30KW	1,459.95	
21P006	HYDRAULIC JACK	260.00	
		⋮	← Additional items
	DISTRICT TOTAL	87,347.16*	
34J261	PORTABLE COMPRESSOR	623.21	
16A300	PORTABLE SPRAYER	930.00	
80D610	PORTABLE GENERATOR, 50KW	3,016.50	
		⋮	← Additional items
	DISTRICT TOTAL	131,219.04*	
	GRAND TOTAL	218,566.20**	

Figure 5-64. Format of District Sales Listing

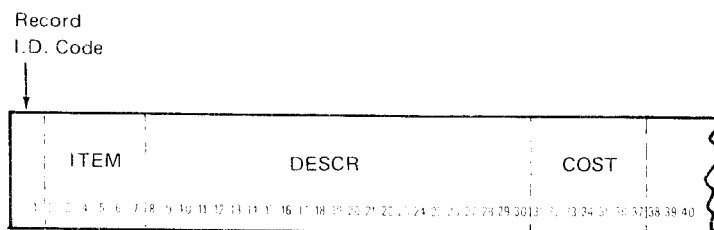

Figure 5-65. Format of Sales Record

This page is intentionally left blank.

# RPG INPUT SPECIFICATIONS

GX21-9094 U/M 050\*  
Printed in U.S.A.

**IBM** International Business Machine Corporation

Program		Punching Instruction		Graphic		Card Electro Number	
Programmer		Date		Punch			

Page 1 of 2 Program Identification 75 76 77 78 79 80

Line	Form Type	Filename	Sequence Number (1-N)		Record Identifying Indicator or Option (O)	Record Identification Codes									Field Location			Field Name	Control Level (L-H)	Matching Fields or Chaining Fields	Field Record Relation	Field Indicators																
			O	R		A	N	1			2			3			From					To	Decimal Positions	Plus	Minus	Zero or Blank												
								Position	Not (N)	C/Z/D Character	Position	Not (N)	C/Z/D Character	Position	Not (N)	C/Z/D Character																						
																											Stacker Select	P/B/L/R										
01	I	INPUT	AA	ØL	ØL	L	C	L																														
02	I		OR	ØL	ØL	L	C	M																														
03	I														2	7																						
04	I														8	30																						
05	I														31	37																						
06	I		BB	ØR	ØR	L	C	R																														
07	I		OR	ØR	ØR	L	C	N																														
08	I														2	7																						
09	I														8	30																						
(A)	I														31	37																						
10	I																																					

# RPG CALCULATION SPECIFICATIONS

Form GX21-9093  
Printed in U.S.A.

**IBM** International Business Machine Corporation

Program		Punching Instruction		Graphic		Card Electro Number	
Programmer		Date		Punch			

Page 1 of 2 Program Identification 75 76 77 78 79 80

Line	Form Type	Control Level (L-O, L9, L8, SR, AN, ØR)						Indicators		Factor 1	Operation	Factor 2	Result Field		Resulting					
		L	Ø	9	SR	AN	ØR	And	And				Name	Length		Decimal Positions	Half Adjust (H)			
																		Not	Not	Not
01	C		Ø1						COST	ADD	DISTOT	DISTOT	Ø2	Indicator 21 is used to signal a change in record type. This technique only works for two record types.						
02	C		Ø2					COST	ADD	DISTOT	DISTOT									
03	C								SETOF				21							
04	C		Ø1						SETON				21							
05	C		ØØ	Ø2	Ø1				DISTOT	ADD	GDTOT	GDTOT	92							
06	C		ØR						DISTOT	ADD	GDTOT	GDTOT								
(B)	C																			
08	C																			

Figure 5-66 (Part 1 of 2). Calculations Using an Artificial Control Break (L0 Indicator)



Program	Date	Punching Instruction	Graphic	Card Electro Number
Programmer				

Page 1 2 of Program Identification 75 76 77 78 79 80

Line	Form Type	Filename	Type (H/D/T/E)		Stack # / Position	Space		Skip			Output Indicators			Field Name	Edit Codes	End Position in Output Record	P/B/L/R	Constant or Edit Word
			Before	After		Before	After	Not	And	And	Not							
01	O	OUTPUT	D	L														
02	O		OR															
03	O																	
04	O																	
05	O																	
06	O		T	RR														
07	O		OR															
08	O																	
09	O																	
10	O																	
11	O		T	2														
12	O																	
13	O																	
14	O																	
15	O																	
16	O																	

Figure 5-66 (Part 2 of 2). Calculations Using an Artificial Control Break (L0 Indicator)

Assume that the following five records are read:

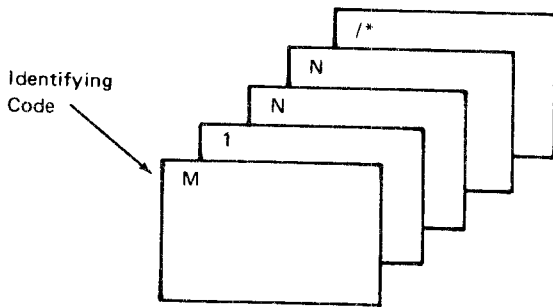

The operations performed on these five records are as follows:

<i>Record</i>	<i>Indicators On</i>	<i>Operations Performed</i>
(1)	L0	01 turns on. No total operations are performed because conditions in lines 5-6 (Calculations sheet) are not met. (Remember that operations conditioned by control level indicators in columns 7-8 are performed first, but are bypassed on the first RPG II cycle.) COST is added to DISTOT. 21 is set on. ITEM, DESCR, and COST are printed out. 01 is turned off. 21 remains on.
(2)	L0, 21	01 is turned on. No total operations are performed. COST is added to DISTOT. ITEM, DESCR, and COST are printed out. 01 is turned off. 21 remains on.
(3)	L0, 21	02 turns on. DISTOT is added to GDTOT. (Conditions for the total operation in line 5 have been met.) DISTOT is printed out. COST is added to DISTOT. 21 is set off. ITEM, DESCR, and COST are printed out. 02 is turned off.
(4)	L0	02 is turned on. No total operations are performed. COST added to DISTOT. ITEM, DESCR, and COST are printed out. 02 is turned off.
(5)	LR	DISTOT added to GDTOT (LR indicator is on). DISTOT and GDTOT printed out.

## Using Control Level Indicators as Calculation Conditioning Indicators

Control level indicators are normally entered in columns 7-8 of the Calculation sheet where they specify which calculations are to be done at total time. They may, however, be used in columns 9-17 also where they indicate which detail operations are to be done on the first record of a control group.

Control level indicators are turned on near the beginning of the program cycle if the contents of the control field on the record just read are different from the contents of the previous control field. Since the indicator is not turned off until the end of the cycle, it is on during total and detail time. Thus, it is available to use as a conditioning indicator during detail time as well as total time.

When an operation is not conditioned by control level indicators specified in columns 7-8 of the Calculation sheet, the operation is done at detail time. If the operation is conditioned by a control level indicator specified in columns 9-17, and not in 7-8 the operation is still done at detail time, but only when the control level indicator is on. And when is the control level indicator on? Only during the processing of the first record in a control group as only the first record in a new group causes a control break.

### Group Printing

In group printing, data from groups of input records is summarized and printed as totals on a report. Sometimes, a field on each record in an input file is accumulated and only the final total is printed. At other times, subtotals are created by adding the contents of a field from a certain group of records and printing the result.

### Printing Only the Final Totals

It is possible to add the contents of a field from all data records, and print only the total accumulated. You may want to do this when you are not interested in any of the detail information, but you do need a summation of that information.

Figure 5-67 shows the coding for a program that finds the totals for two fields of information and prints only those totals. Notice, when printing only totals, the Input sheet need only contain those fields that will be used in the calculations or in the printing. The Output-Format sheet shows only a total line (T in column 15). That line is not printed until the last record has been processed (LR in columns 24-25). Then, one line is printed, containing the total quantity, total cost, and a constant (see insert on Output-Format sheet).

File Description Specification

Line	Form Type	Filename	File Type		Mode of Processing		Device	Symbolic Device	Name of Label Exit	Extent Exit for DAM	File Addition/Unordered	
			File Designation	End of File	Length of Key Field or of Record Address Field	Record Address Type					Number of Tracks for Cylinder Overflow	Number of Extents
0 2	F	SUMMING IP										
0 3	F	TOTALS D					MFCUL					PRINTER

RPG INPUT SPECIFICATIONS

Line	Form Type	Filename	Sequence	Record Identifying Indicator	Record Identification Codes			Field Location		Field Name	Field Indicators
					1	2	3	From	To		
0 1	I	SUMMING AA									
0 2	I							5		QTY	
0 3	I							9		L2COST	

RPG CALCULATION SPECIFICATIONS

Line	Form Type	Indicators	Factor 1	Operation	Factor 2	Result Field		Resulting Indicators	Comments
						Name	Length		
0 1	C		QTY	ADD	TOTQTY	TOTQTY	60		
0 2	C		COST	ADD	TOTCOS	TOTCOS	82		

RPG OUTPUT

Line	Form Type	Filename	Output Indicators	Field Name	End Position in Output Record	Constant or Edit Word					
						No	No	4	D	M	Suppress
0 1	O	TOTALS									
0 2	O										
0 3	O										
0 4	O										
0 5	O										

1363 178.35 TOTALS FOR QTY AND COST

Figure 5-67. Group Printing — Printing Only the Final Totals

### *Group Printing of Subtotals*

Figure 5-68 shows group printing of subtotals. The input records for the program contain item, quantity, and cost fields; they were previously sorted by like items.

Figure 5-69 shows the coding to produce the report. Since a subtotal is to be calculated for each different type of item, the field ITEM is designated as a control field on Input specifications. The calculations show that, as each input record is read, the values in the QTY and COST are accumulated into subtotal fields. At each control break, the subtotal fields, SUBQTY and SUBCOS, are accumulated into final total fields.

The Output-Format sheet in Figure 5-69 shows coding for three different types of printed lines:

- A detail line, which is printed for each input record read. Note the use of a control level indicator on the ITEM field. This causes the field to be printed only for the first record of each control group (see Figure 5-68), making the report less cluttered and easier to read. This is known as *group indication* (see index entry).
- A total line, conditioned by L1, which is printed only after each complete group of like items was read, that is, after each control break.
- A final total line, conditioned by LR, which is printed only once, after all records were processed.

If you want the subtotals to be the sums of only the quantities and cost in one section (for instance, only those quantities and costs under item ABCD), it is necessary to set those fields back to zero after they have been printed and added into the final totals. This process is indicated in column 39. The B entries indicate that the totals, SUB QTY and SUBCOS, are to be blanked out, or zeroed out, after they are printed, when the control field (ITEM) changes. They are set back to zero so that they can correctly accumulate the quantities and costs for the next item.



RPG CALCULATION SPECIFICATIONS

Form GX21-9093  
Printed in U.S.A.

IBM International Business Machine Corporation

Program	Date	Punching Instruction	Graphic	Card Electro Number
Programmer		Punch		

Page 03 of 75 76 77 78 79 80  
Program Identification

Line	Form Type	Control Level (L, L, L, L, L, SR, AM, OR)	Indicators			Factor 1	Operation	Factor 2	Result Field		Decimal Positions High Adjust (H) Low Adjust (L)	Resulting Indicators			Comments
			And	And	And				Name	Length		Plus	Minus	Zero	
01	C					QTY	ADD	SUBQTY	SUBQTY	60					
02	C					COST	ADD	SUBCOS	SUBCOS	62					
03	C	LL				SUBQTY	ADD	FINQTY	FINQTY	80					
04	C	LL				SUBCOS	ADD	FINCOS	FINCOS	82					

RPG OUTPUT SPECIFICATIONS

GX21-9090 U/M 090\*  
Printed in U.S.A.

IBM International Business Machine Corporation

Program	Date	Punching Instruction	Graphic	Card Electro Number
Programmer		Punch		

Page 04 of 75 76 77 78 79 80  
Program Identification

Line	Form Type	Filename	Type (H/D/T/E)		Space	Skip	Output Indicators			Field Name	End Position in Output Record	P/B/L/R	Constant or Edit Word
			Stacker # / Fetch (F)	Before			After	And	And				
01	O	OUTPUT	D	I	O								
02	O								LI	ITEM	4		
03	O									QTY	3	13	
04	O									COST	3	23	
05	O	T 21							LI				
06	O									SUBQTY	3B	13	
07	O									SUBCOS	3B	23	
08	O											35	'SUBTOTALS'
09	O	T 20							LR				
10	O									FINQTY	3	13	
11	O									FINCOS	3	23	
12	O											38	'FINAL TOTALS'

Commas	Zero Balances to Print	No Sign	CR	-	X = Remove Plus Sign
Yes	Yes	1	A	J	Y = Date
Yes	No	2	B	K	Field Edit
No	Yes	3	C	L	Z = Zero Suppress
No	No	4	D	M	

● Figure 5-69 (Part 2 of 2). Group Printing – Printing Subtotals

### *Group Printing with Two Control Level Indicators*

Certain programs require two or more control levels. Nine levels (L1-L9) are possible. This program uses two of these, L1 and L2, to produce the report shown in Figure 5-70.

Each record in the input file contains the part number of an item, the quantity of items sold, and a number to identify the salesman who sold those items. The file has been previously arranged by salesman number. That is, all records for salesman number 12 are together, all records for salesman number 13 are together, and so forth. Records are also grouped by item number within each salesman group.

On the printed report, the salesman number is to be printed once; part numbers are in the next column with the sums of quantities for each part number in the rightmost column. Subtotals are printed for each salesman and a final total is printed at the end of the report.

Figure 5-71 shows the coding to produce the report. Since the PARTNO field changes most frequently (there are several part numbers for each salesman) that field is the lowest level control field and is assigned indicator L1 on the

Input sheet. The next higher level control field, which does not change as frequently, is SLSNUM; therefore, SLSNUM is assigned indicator L2. The calculation on the first line (01 indicator specified) occurs for every record that is read. QTY is added to a total, QTYSUM. Line 2 occurs only when the control field, PARTNO, changes, because L1 (columns 7 and 8) controls this calculation. So, when L1 is on, QTYSUM is added to another total, SUBTOT. The third line describes the calculation of a final total, FINOT. This calculation occurs when L2 is on (when the control field, SLSNUM, changes).

When the higher level control level indicator (L2) is on, the lower level indicator (L1) is also on. As shown on the Output-Format sheet, when L1 is on, PARTNO and QTYSUM are printed (lines 03 and 04). However, the field SLSNUM is conditioned by L2, so it is printed only for the first record of each L2 control group. When L2 is on, SUBTOT and the constant SUBTOTAL are printed (lines 05-07). When LR is on, FINTOT and the constant FINAL are printed.

The two subtotals, QTYSUM and SUBTOT, are zeroed after printing by entering a B in column 39 (lines 04 and 06). Detail lines need never be blanked after, nor does a final total (regulated by the LR indicator).

SALESMAN NUMBER                      PART NUMBER

1.2	A235	375		
1.2	B124	100		
1.2	C140	200		
		675	SUBTOTAL	
1.3	A235	50		
1.3	C140	400		
		450	SUBTOTAL	
1.4	B124	600		
1.4	C140	325		
1.4	D896	110		
1.4	E091	370		
		1405	SUBTOTAL	
		2530	FINAL	

Figure 5-70. Group Printing — Report Produced Using Two Control Level Indicators

### File Description Specification

Line	Form Type	Filename	File Type				Mode of Processing				Device	Symbolic Device	Labels S/M/E/M	Name of Label Exit	Extent Exit for DAM		File Addition/Unordered			
			I/O/U/C/D	P/S/C/R/T/D	E	A/D	F/V/S/M/D	Sequence	File Format	Block Length					Record Length	L/R	A/P/I/K	I/D/T or 2	Type of File Organization or Additional Area	Overflow Indicator
0 2		ITEMTOT IP																		
0 3		SLSRPREPTO																		

### RPG INPUT SPECIFICATIONS

GX21-9094 U/M 050\*  
Printed in U.S.A.

Program	Punching Instruction	Graphic	Card Electro Number
Programmer	Date	Punch	

Page 02 of 75 76 77 78 79 80  
 Program Identification

Line	Filename	Sequence	Record Identification Codes									Field Location			Field Indicators		
			1	2	3	4	5	6	7	8	9	From	To	Decimal Positions	Plus	Minus	Zero or Blank
0 1	ITEMTOT AA	01															
0 2																	
0 3																	
0 4																	
0 5																	

Figure 5-71 (Part 1 of 2). Group Printing with Two Control Level Indicators



### RPG CALCULATION SPECIFICATIONS

Form GX21-9093  
Printed in U.S.A.

Program		Punching Instruction	Graphic	Card Electro Number	Page 1 of 2	75 76 77 78 79 80
Programmer	Date		Punch		Page 03 of	Program Identification

Line	Form Type	Indicators						Factor 1	Operation	Factor 2	Result Field		Resulting Indicators		Comments
		And	And	And	And	And	And				Name	Length	Arithmetic	Plus Minus Zero	
01	C							QTY	ADD	QTYSUM	QTYSUM	60			
02	C	L1						QTYSUM	ADD	SUBTOT	SUBTOT	60			
03	C	L2						SUBTOT	ADD	FINTOT	FINTOT	80			
04	C														

### RPG OUTPUT SPECIFICATIONS

GX21-9090 U/M 050\*  
Printed in U.S.A.

Program		Punching Instruction	Graphic	Card Electro Number	Page 1 of 2	75 76 77 78 79 80
Programmer	Date		Punch		Page 04 of	Program Identification

Line	Form Type	Filename	Space				Skip			Output Indicators			Field Name	End Position in Output Record	Constant or Edit Word	
			Before	After	Before	After	Before	After	Before	After	Before	After				
01	O	SLSRPT														
02	O													2		
03	O													10		
04	O													17		
05	O		T	2L										17		
06	O													17		
07	O													27	'SUBTOTAL'	
08	O		T	30										17		
09	O													17		
10	O													24	'FINAL'	

Figure 5-71 (Part 2 of 2). Group Printing with Two Control Level Indicators



## TESTB Operation Code

Figure 5-74 is a sample Calculation sheet with the TESTB operation code. This operation code causes specified bits identified in Factor 2 to be tested for an off or on condition. Resulting indicators in columns 54-59 are set depending upon the conditions. At least one resulting indicator must be used with the TESTB operation, and as many as three can be named for one operation. Two indicators may be the same for one TESTB operation, but not three. Resulting indicators in these columns have the following meanings:

- Columns 54-55: An indicator in these columns is turned on if all the bits in Factor 2 are off (set to 0).
- Columns 56-57: An indicator in these columns is turned on if two or more bits were tested and found to be of mixed status, some bits on and other bits off.
- Columns 58-59: An indicator in these columns is turned on if all the bits in Factor 2 are on (set to 1).

In Figure 5-74, bits 4, 5, and 6 in the binary field named CODE are tested. Resulting indicator 66 is turned on if bits 4, 5, and 6 are off. If some are on and others off, resulting indicator 77 is turned on. If they are all on, resulting indicator 88 is turned on.

All other specifications are the same as those specified under *BITON Operation Code*. However, you need not define the Result Field as one position in length, since this is done when the field is used in a BITON or BITOF operation code.

IBM		RPG CALCULATION SPECIFICATIONS		Form GX21-9093 Printed in U.S.A.								
Program		Punching Instruction		Card Electro Number								
Programmer		Date		Page 1 2 of Program Identification 75 76 77 78 79 80								
Line	Form Type	Control Level (LD, LG, LR, SR, AN, OR)	Indicators			Factor 1	Operation	Factor 2	Result Field		Resulting Indicators	Comments
			And	And	Not				Name	Length		
0 1	C											
0 2	C							BITOF '034'	CODE	1		

Note: The shaded columns are not used. Leave them blank.

Figure 5-73. The BITOF Operation Code

IBM		RPG CALCULATION SPECIFICATIONS		Form GX21-9093 Printed in U.S.A.								
Program		Punching Instruction		Card Electro Number								
Programmer		Date		Page 1 2 of Program Identification 75 76 77 78 79 80								
Line	Form Type	Control Level (LD, LG, LR, SR, AN, OR)	Indicators			Factor 1	Operation	Factor 2	Result Field		Resulting Indicators	Comments
			And	And	Not				Name	Length		
0 1	C											
0 2	C							TESTB '456'	CODE		66 77 88	

Figure 5-74. The TESTB Operation Code

## Example

Fields are sometimes present in customer master files to indicate particular types of customers. When such a master file is created, each of the conditions indicating a particular customer type is represented in a record by a one-position field. Since each position occupies one byte of storage, four positions indicating customer types will be stored in four bytes of storage. You can use binary field operations to convert each one-byte record position to one bit of information on disk. Therefore, four bytes of information can be reduced to four bits of information on disk.

For example, assume you have a customer master file on cards. You have four columns containing the following information:

- Whether the customer is a wholesaler or retailer.
- If the customer is entitled to a discount.
- If orders should be checked by the credit department.
- If due to a bad payment history, the shipment should be sent cash on delivery.

Now you want to place the card file on disk, and the information from the four columns in four bits in a binary field labeled CHECK. The four columns will be labeled WHLSE, DSCT, CREDIT, and COD respectively. The following operations should be performed:

1. If WHLSE is equal to 1, turn on bit 0 in CHECK.
2. If DSCT is equal to 1, turn on bit 1 in CHECK.
3. If CREDIT is equal to 1, turn on bit 2 in CHECK.
4. If COD is equal to 1, turn on bit 3 in CHECK.

Figure 5-75 shows correct coding for this problem. Remember that before setting up data in a binary field, the binary field should be set to binary zero. This can be done by the BITOF instruction (Line 1, Figure 5-75).

## INCREASING THE SPEED OF OPERATIONS (DUAL I/O AREAS)

During the normal RPG II cycle, a record is read, calculations are performed, and output is produced. The cycle is repeated for each record.

The speed at which the cycle is done depends upon the speed at which records are read and output produced. Calculations take less time than reading, printing, writing to disk, or punching. The speed of doing output can be increased by using dual input/output areas.

### Dual Input Areas

When dual input areas are used, the program cycle is changed. First a record is read. At the same time, calculations are being performed on this record, another record is being read. Thus, the contents of two records are in the computer at the same time. Figure 5-76 shows how the records are processed when two input areas are used.

Dual input areas can be specified for sequential disk files or direct disk files processed sequentially, for card files designated as input files, or for tape input files. No stacker selection can be specified for card files. Dual input areas cannot be specified for combined or update files, table, or demand files. When shared input/output is specified in the header card, all devices which can use shared input/output are automatically excluded from use of dual input areas. *(Note to Model 6 Programmers: Dual input areas can be used for data recorder input files. Dual input areas cannot be assigned to disk, data recorder, or ledger card device files using a shared input/output area, specified in column 48 of the Control sheet.)*

IBM		International Business Machine Corporation		RPG CALCULATION SPECIFICATIONS															Form GX21 9093 Printed in U.S.A.	
Program				Punching Instruction				Graphic				Card Electro Number				Page 01 of 75 76 77 78 79 80				
Programmer				Date				Punch								Program Identification				
C Line	Form Type	Control Level (1-9)	Indicators			Factor 1	Operation	Factor 2	Result Field		Decimal Positions Half Adjust (H)	Resulting Indicators			Comments					
			And	And	Not				Name	Length		Arithmetic	Plus	Minus		Zero				
01	C																			
02	C				WHSLE	BITOF	'01234567'	CHECK	1											
03	C				DSCIT	COMP	1									10				
04	C				CREDIT	COMP	1									11				
05	C				COD	COMP	1									12				
06	C		10			BITON	'0'	CHECK								13				
07	C		11			BITON	'1'	CHECK												
08	C		12			BITON	'2'	CHECK												
09	C		13			BITON	'3'	CHECK												
10	C																			

Figure 5-75. Example of Binary Field Operations

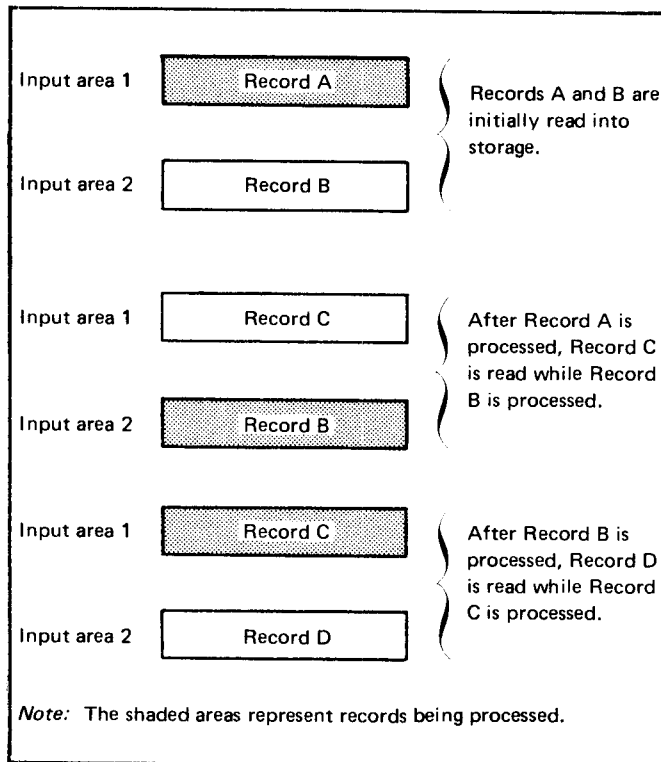

Figure 5-76. Dual Input Areas

Dual input areas require more computer storage space than one input area, because two records are in storage during each cycle. If you have a large program, you might not have enough storage space to accommodate two input areas. The effect of dual input areas can be determined only if you have knowledge of a program's processing requirements and experience in RPG II programming. In some cases, you can only make a final determination by actual experimentation. (Note to Disk Programmers: If your program plus two input areas require more space than is available, certain RPG II object cycle routines remain on disk during execution and are called into storage as needed. If too many routines remain on disk, the performance of your program may be decreased by the use of dual input areas rather than increased.)

### Specifications

One entry on the File Description sheet is required to specify dual input areas: any digit (1-9) in column 32 assigns dual input areas for the specified file. Figure 5-77 shows the file MASTER has been assigned dual input areas.

File Description Specification																																																																									
Line	Form Type	File Type														Mode of Processing												Device	Symbolic Device	Label S/I/E/M	Name of Label Exit	Extent Exit for DAM		File Address/Unordered																																							
		File Designation														Record Address Field																Core Index	Number of Tracks for Cylinder Overflow																																								
		End of File														Record Address Type																	Number of Extents						Tape Rewind																																		
3	4	5	6	7	8	9	10	11	12	13	14	15	16	17	18	19	20	21	22	23	24	25	26	27	28	29	30	31	32	33	34	35	36	37	38	39	40	41	42	43	44	45	46	47	48	49	50	51	52	53	54	55	56	57	58	59	60	61	62	63	64	65	66	67	68	69	70	71	72	73	74		
0 2	F	MASTER IP F														256 128												2				01		01																																							
0 3	F																																																																								
0 4	F																																																																								
0 5	F																																																																								
0 6	F																																																																								
0 7	F																																																																								
0 8	F																																																																								
0 9	F																																																																								
1 0	F																																																																								
	F																																																																								
	F																																																																								

Specification of dual input areas for card files is also done with a digit in column 32.

Figure 5-77. Specifying a Dual Input Area

### Dual Output Areas

When dual output areas are used, the program cycle is changed. A record is written or punched out at the same time calculation and output operations are being done internally to produce the next record. (Calculation operations are not done at the same time as writing or punching when only one output area is used.) Figure 5-78 shows how output records are produced using dual output areas.

Dual output areas, like dual input areas, require more computer storage. Consequently, the same space considerations that apply to dual input areas also apply to dual output areas. Dual output areas can be used for sequential and direct disk output files, Model 10 printer files (5203 printer), tape files, and card output files. Dual output areas cannot be specified for combined or update files. Also, dual output areas cannot be assigned to Model 6 data recorder, disk or ledger card device files and Model 10 or Model 15 disk files that use a shared input/output area.

### Specifications

One entry is required on the File Description sheet to specify dual output areas: any digit (1-9) can be entered in column 32 for an output file. Figure 5-79 shows the file PRINT has been assigned dual output areas.



**Additional Uses of Indicators**

1. What effect do halt indicators have on System/3 operations? How can you use halt indicators to handle error situations?
2. Describe a method to eliminate an output file for one program run without having to rewrite specifications and recompile the program.
3. When conditioning a calculation specification with an indicator, what happens when the indicator is on? What happens when it is off?
4. Describe what the TESTZ operation does.
- 5.

Factor 1	Operation	Factor 2	Result Field		Decimal Positions	Half Adjust (H)	Resulting Indicators					
			Name	Length			Arithmetic	Plus	Minus	Zero		
							1 > 2	1 < 2	1 = 2			
							Lookup(Factor 2) is	High	Low	Equal		
18 19 20 21 22 23 24 25 26 27	28 29 30 31 32	33 34 35 36 37 38 39 40 41 42	43 44 45 46 47 48	49 50 51	52	53	54	55	56	57	58	59
	TESTZ		TEST				93	94	95			

Using this TESTZ specification, tell what the status of indicators 93, 94, and 95 will be when the field TEST contains:

- a. ABC
- b. &/\*
- c. JOH
- d. 789

6.

Factor 1	Operation	Factor 2	Result Field		Decimal Positions	Half Adjust (H)	Resulting Indicators					
			Name	Length			Arithmetic	Plus	Minus	Zero		
							1 > 2	1 < 2	1 = 2			
							Lookup(Factor 2) is	High	Low	Equal		
18 19 20 21 22 23 24 25 26 27	28 29 30 31 32	33 34 35 36 37 38 39 40 41 42	43 44 45 46 47 48	49 50 51	52	53	54	55	56	57	58	59
FIRST	COMP	SECOND					96	97	98			



Using this COMP specification, tell what the status of indicators 96, 97, and 98 will be when the fields FIRST and SECOND contain:

- |    |              |               |
|----|--------------|---------------|
|    | <i>First</i> | <i>Second</i> |
| a. | 16942        | 17942         |
| b. | 16000        | 15000         |
| c. | 19645        | 19645         |
| d. | 18921        | 18931         |

### Controlling Operations on the Basis of the Next Record in a File

7. Basically, what does the look ahead facility allow you to do? What limitations apply to its use?
  
8. To the input specifications given add those which will allow you to look ahead in order to read the next part number (PARTNO) and next code in column 96.

<b>IBM</b> International Business Machine Corporation		<b>RPG INPUT SPECIFICATIONS</b>												GX21-9094 U/M 050 Printed in U.S.A.																										
Program _____						Punching Instruction _____						Graphic _____						Card Electro Number _____																						
Programmer _____						Date _____						Page 1 2 of _____						Program Identification 75 76 77 78 79 80																						
I	Line	Form type	Filename	Sequence	OR	Number (1-N)	Options (O)	Record Identifying Indicator	Record Identification Codes									Field Location		Field Name	Control Level (L1-L9)	Matching Fields or Chaining Fields	Field Record Relation	Field Indicators																
									1			2			3			From	To					Plus	Minus	Zero or Blank														
									Position	Not (N)	C/Z/D	Character	Position	Not (N)	C/Z/D	Character	Position	Not (N)	C/Z/D					Character	Stagger Select	P/B/L/R	Decimal Positions	Plus	Minus	Zero or Blank										
0 1	I		INPUT	AA				L0	96	C9																														
0 2	I																1	6	PARTNO																					
0 3	I																7	32	DISC																					
0 4	I																33	37	QTYOH																					
0 5	I																																							

### Moving Data

9. With MOVE, which position of Factor 2 is moved first and where is it positioned in the Result Field?
  
10. What happens in a MOVE operation if Factor 2 is larger than the Result Field? What happens if it is smaller?
  
11. With MOVE, which position of Factor 2 is moved first and where is it positioned in the Result Field?
  
12. What sign does a numeric Result Field have after a MOVE operation?



### **Special Uses of Control Level Indicators**

22. When would you use the L0 indicator?
23. How can you specify calculations to be performed only on the first card of a group?
24. When should you specify blank after (B in column 39 of the Output-Format sheet) for an output field?

### **Binary Field Operations**

25. What are bit switches used for?
26. Code the calculation specification to:
  - a. Set on bits 4 and 7 in a field called TESTER.
  - b. Set off bits 1, 2, and 3 in TESTER.
  - c. Test to see whether bits 1, 2, and 3 in TESTER are all on or all off. Set on indicator 01 if they are all on and set on indicator 02 if they are all off.

### **Dual Input/Output Areas**

27. For which device and file types can you specify dual input/output areas on your system?

## Answers To Review 5

1. Halt indicators may be turned on as record identifying indicators, as a result of a test on a field, or as a result of calculations. When they are on, they cause the system to halt after all calculations and output operations have been performed for that program cycle.

Because a program cycle is completed before the system halts, operations may be performed on erroneous data. Halt indicators, when used as conditioning indicators, allow you to bypass calculations and output operations which would usually be done. They also allow you to print error messages and stacker select any cards with erroneous information.

2. Use an external indicator (U1-U8) to condition the output file and operations specified for that file. When the indicator is on the file is used; when it is off, the file is not used. The file is conditioned by an external indicator specified in columns 71-72 of the File Description sheet. The output specifications should be conditioned by that same external indicator entered in columns 23-31 of the Output Specifications Sheet.
3. If the indicator is on, the step will be executed. If the indicator is off, the step will not be executed.
4. TESTZ examines the zone portion of the leftmost character in an alphanumeric field. If that position contains & or A-I, the plus indicator will turn on. If that position contains -, {, or J-R, the minus indicator turns on. For all other characters, the zero indicator turns on.
5.

	93	94	95
a.	on	off	off
b.	on	off	off
c.	off	on	off
d.	off	off	on
6.

	96	97	98
a.	off	on	off
b.	on	off	off
c.	off	off	on
d.	off	on	off
7. Look ahead allows you to use data on the next record to be processed. Normally only the data on the record currently being processed is available to the RPG II program. Look ahead is most often used with input files. If it is used with combined or update files, information in the look ahead field while the combined or update file is being processed will be from the record currently being processed, not from the next record in the file.
8. \*\* must be specified in columns 19-20 to indicate that the fields listed are to be looked at in the next card available for processing. Look ahead fields must be given different field names than those used when describing the file. Any alphabetic characters may be used in columns 15-16.

IBM		RPG INPUT SPECIFICATIONS										Date: _____				
Program: _____		Function: _____		Language: _____		Card Layout Number: _____		Page: _____		Revision: _____		Date: _____				
I	Line	Field Name	Sequence	Record Identification Codes						Field Location		Field Name	Field Indicators			
				Position	Position	Position	Position	Position	Position	From	To		Indicator	Indicator		
01	I	INPUT	AA	10	96	C9										
02	I															
03	I															
04	I															
05	I		AA	**												
06	I															
07	I															
08	I															
09	I															
10	I															
11	I															
12	I															
13	I															
14	I															
15	I															
16	I															
17	I															
18	I															
19	I															
20	I															
21	I															
22	I															
23	I															
24	I															
25	I															
26	I															
27	I															
28	I															
29	I															
30	I															
31	I															
32	I															
33	I															
34	I															
35	I															
36	I															
37	I															
38	I															
39	I															
40	I															
41	I															
42	I															
43	I															
44	I															
45	I															
46	I															
47	I															
48	I															
49	I															
50	I															

9. The righthand, low-order position of Factor 2 is moved first, to the righthand, low-order position of the Result Field.
10. If Factor 2 is larger, the number of positions moved will be equal to the size of the Result Field. If Factor 2 is smaller, the whole field will be moved and the lefthand positions of the Result Field will be unchanged.
11. With MOVE, the leftmost position of Factor 2 is moved first to the leftmost position of the Result Field.
12. The sign of the Result Field after a MOVE operation is performed will be the same as that of the low-order character of Factor 2 unless Factor 2 is smaller than the Result Field in which case the sign is unchanged.
13. a. 87653456<sup>+</sup>  
b. 8765<sup>-</sup>  
c. 4321<sup>+</sup>  
d. 34564321<sup>-</sup>
14. Branching alters the sequence in which calculations are executed. It allows you to:
  - a. Skip calculation operations.
  - b. Execute operations in an order other than the normal sequential order.
  - c. Perform the same calculations several times in one cycle.
15. Branching in RPG II is specified by the operations GOTO and TAG. GOTO tells the computer to branch to a location indicated in Factor 2 of the instruction. The TAG statement is placed at the point in your program to which you want to branch. The name in Factor 1 of the TAG statement is the same as the name in Factor 2 of the appropriate GOTO. Every GOTO requires a TAG or the program will not know where to branch to. Several GOTO statements may branch to the same TAG, but the name on each TAG statement must be unique.

16. Condition several GOTO statements with the various record type indicators. Write the set of specifications for each record type separately and include them in the program. The set of specifications for each record type will begin with a TAG statement and end with a GOTO statement which branches to the end of all calculations. The program will test the record type and branch to the correct set of specifications. At the end of the set of specifications, it will branch around all other specifications to the end of the calculation section.
17. If a program has a loop, there must be some way to stop the looping. The branch back instruction must be conditioned so that when certain conditions have been met, the statement will not be executed. If this condition is not specified or cannot be met, the program will go into an endless loop.
18. A subroutine can be used whenever the same calculations must be executed at several different places in a program.
19. The first line of a subroutine must have the BEGSR operation code in columns 28-32 with the subroutine name in Factor 1. The last line in a subroutine must have ENDSR operation code in columns 28-32. This line can have a name in Factor 1, and this name can then be referenced by a GOTO statement. Every subroutine line must have SR in columns 7-8.
20. No branches can be made from a GOTO statement within a subroutine to a TAG statement outside that subroutine. No branches can be made from outside the subroutine to a TAG statement within the subroutine.
21. All subroutines must appear on the Calculation sheet after all detail and total calculations.
22. L0 would be used if you need to perform some calculation steps at total calculation time and there is no normal control level indicator (L1-L9) available. A common use of this is to set on the other control level indicators when control fields are not available.
23. Detail calculations are distinguished from total calculations by the fact that columns 7-8 of the Calculation sheet are left blank for detail calculations. Since the control level indicator stays on through detail calculations it can be used like any other indicator in columns 9-17 to control detail calculations. The control level indicator will be on for only the first card of a new control group.
24. Blank after should be used to reset a field to zero that is used to accumulate and print a total for each control group. This allows the field to start with a zero value for the new control group.
25. Bit switches are used to code and test for specified situations. With System/3 Model 10 Disk System and Model 6, they are stored in one-byte alphameric fields in storage and on disk. One example is credit information in an accounts receivable file. The first bit might mean a COD only; the second, payment due in 30 days; the third, credit limit \$1000; etc. When these conditions are coded as bit switches they take up less disk space than single character codes that might be used in the same way.
26. See coding sheet.



*Model 6:*

- DISK input files (sequential and direct only; no shared I/O)
- DISK output files (sequential and direct only; no shared I/O)
- DATA96 input files

*Model 15:* Same as Model 10 Disk System, plus:

- 2501 input files
- MFCM input files (no stacker select; no table or demand files)
- MFCM output files (no stacker select)





**CHAPTER 6 DESCRIBES:**

How to assign match fields to one or more files.

Use of match fields to sequence check records in a file.

Using matching records to control the processing of multiple input files.

**BEFORE READING THIS CHAPTER YOU SHOULD BE ABLE TO DESCRIBE:**

How to identify input record types on the Input sheet.

How to use field-record relation.

How to specify stacker selection on the MFCU.

RPG II object program cycle.

**AFTER READING THIS CHAPTER YOU SHOULD BE ABLE TO DESCRIBE:**

Checking the sequence of records within a file using match fields.

Using match fields with field-record relation for more than one record type in a file.

Matching records when there is only one record type in a file.

RPG II logic for processing files by matching records.

Matching records when there are more than one record type in a file.

Matching records when all of the records in one of the files have been processed.

Using match fields and control fields in the same file.

How to determine whether a file should be primary or secondary.

*Note:* You can use the review questions contained in *Review 6* at the end of this chapter to test your comprehension of the topics in the chapter. Answers follow the review questions.

## INTRODUCTION

*Match fields* are data fields on separate records that are compared to establish a relationship between the records. Match fields have two functions, depending on whether the related records are the same input type file or in separate input type files. (An input type file can be an input, update, or combined file.)

Within a file, match fields are used to *check the sequence of records* on which they appear. The sequence checking is accomplished by comparing match fields in one record with the match fields in the next record *of the same file*. When two or more input type files are used by a program, the sequence of each file can be checked just as sequence was checked for a single file. All files that are sequence checked by match fields must be in the same sequence, either ascending or descending.

In addition to sequence checking records within a file, match fields can also be used to establish a relationship between records that are in separate files. That is, match fields can be used to *match records from two or more input type files* to determine which record is to be processed on the current cycle. If two files are used in the same job and you do not specify the order of processing, the primary file is completely processed first. Only then are records from secondary files processed. By specifying that the order of processing is to be determined by comparing the contents of match fields, however, you can cause records from secondary files that are related to a record in the primary file to be processed before the next primary record.

The processing of more than one input type file, with or without match fields, is termed *multifile processing*. Selection of records from more than one file based on the contents of match fields is known as multifile processing by *matching records*.

Multifile processing is commonly used in applications where data files are set up to contain only a certain type of information. For example, a master payroll file might contain data which does not change often, such as an employee's pay rate. Another payroll file, which would consist of new records every week, might contain data such as the number of hours an employee worked in the week. To produce a paycheck or other report, information from both files must be used. Furthermore, the records from the two files must be processed in a particular order. Matching records can be used both to determine which record to process on each program cycle and to sequence check the records within each file.

*Note to Disk Programmers:* For ease of depicting input records and files, card-like records are shown in illustrations throughout this chapter. This does not imply that the processing must be done using card files. The files can be read from any System/3 device that can be used as an input device. Also, throughout the chapter, two input-type files are used in examples to illustrate RPG II logic for matching records. RPG II logic and the rules for record selection do not change when more than two files are used. See the RPG II reference manual for your system for examples using more than two files.

## CHECKING SEQUENCE OF RECORDS WITHIN A FILE

### File Containing Only One Record Type

As you know, an A or D entry made in column 18 of a file description specification indicates that the records in the file described are to be in sequence. If you specify that the file EMPLOYEE is to be in ascending (A) sequence, which employee records in Figure 6-1 are in the correct order? Actually all three arrangements show the file in ascending order: the first is sequenced by department number, the second by name, and the third group by employee number.

As you can see then, before the program can check the sequence of records in a file, you must specify the field or fields which are to determine the order. The fields on which the sequence is to be checked (called match fields) are identified on the Input sheet by coding one of the entries M1-M9 in columns 61-62 (see Figure 6-2).

Records within a file may be sequenced on the basis of one or more data fields. Up to nine fields may be used by assigning one of the entries M1-M9 to each match field. Entering M1 on the same line as you describe the DEPT field (Figure 6-2) causes the records to be sequence checked according to department number. Thus, this file should be in ascending order as shown in the first group of Figure 6-1.

When you specify more than one match field to check sequence, the program considers all the match fields to be one continuous field, even though the fields may not be adjacent in a record. For this reason, all match fields assigned to a particular record type are considered to have the same type of data (alphameric or numeric). The individual fields are checked in order according to the level of the match field entry assigned to the field. M1 is the lowest level; M9 is considered the most important.

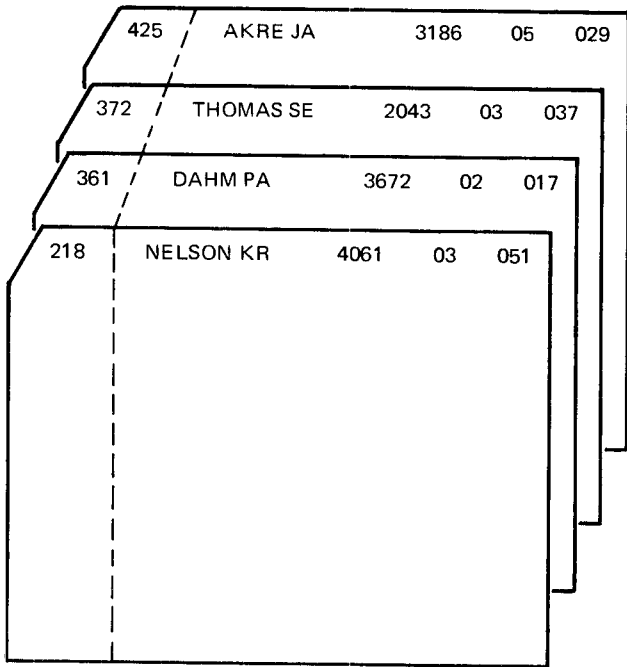

DEPARTMENT  
NUMBER

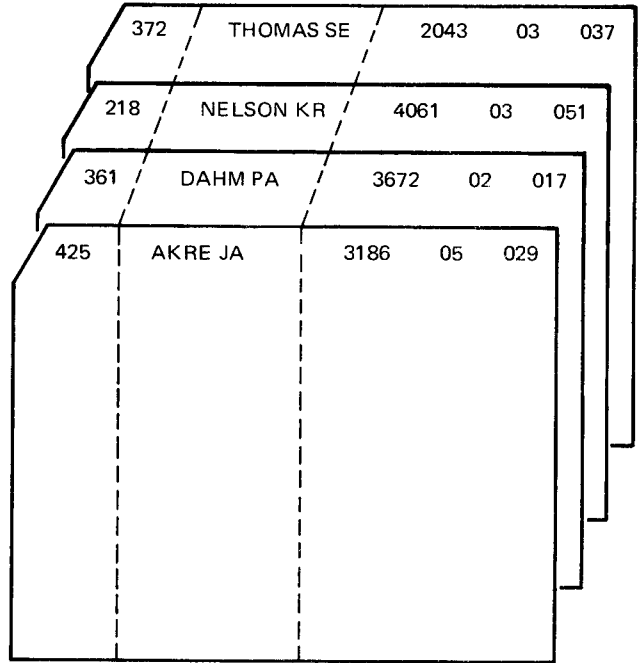

EMPLOYEE  
NAME

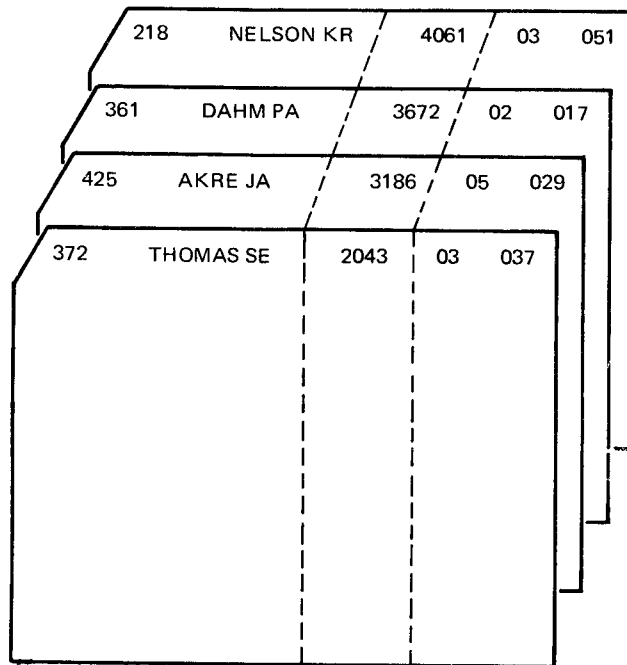

EMPLOYEE  
NUMBER

Figure 6-1. Sequenced Files

I		Filename	Sequence Number (L/N) Option (O)	Record Identifying Indicator or A	Record Identification Codes															Field Location		Field Name	Control Level (L-Lg)	Matching Fields or Chaining Fields	Field Record Relation	Field Indicators				
Line	Form Type				Position	Not (N) C/Z/D	Character	Position	Not (N) C/Z/D	Character	Position	Not (N) C/Z/D	Character	Position	Not (N) C/Z/D	Character	Position	Not (N) C/Z/D	Character	From	To					Plus	Minus	Zero or Blank		
0 1	I	EMPLOYEEENS	Ø	Ø																										
0 2	I																													
0 3	I																	1	3	DEPT		ML								
0 4	I																	5	13	NAME										
0 5	I																	16	19	NUMBER										
0 6	I																	22	23	REGION										
0 7	I																	26	28	DSTRCT										

Figure 6-2. Assigning a Match Field for Sequence Checking

The input specifications shown in Figure 6-3 show that three fields on an EMPLOYEE record are to be used for sequence checking. Since all records in a particular region are to be together, the REGION field is assigned the highest (M3) match field entry and, thus, is checked first. DSTRCT is the next match field (M2), and DEPT is the last (M1).

Figure 6-4 shows three records from the EMPLOYEE file. The three match fields shown would be considered one field. If the file is specified to be in ascending order (on the File Description sheet), the records are in order since 03037372 is lower than 03051218, which is lower than 05029425. However, if the file is to be in descending sequence, record 1 and record 3 must be switched.

I		Filename	Sequence Number (L/N) Option (O)	Record Identifying Indicator or A	Record Identification Codes															Field Location		Field Name	Control Level (L-Lg)	Matching Fields or Chaining Fields	Field Record Relation	Field Indicators				
Line	Form Type				Position	Not (N) C/Z/D	Character	Position	Not (N) C/Z/D	Character	Position	Not (N) C/Z/D	Character	Position	Not (N) C/Z/D	Character	Position	Not (N) C/Z/D	Character	From	To					Plus	Minus	Zero or Blank		
0 1	I	EMPLOYEEENS	Ø	Ø																										
0 2	I																													
0 3	I																	1	3	DEPT		ML								
0 4	I																	5	13	NAME										
0 5	I																	16	19	NUMBER										
0 6	I																	22	23	REGION		M3								
0 7	I																	26	28	DSTRCT		M2								

Figure 6-3. Assigning More than One Match Field for Sequence Checking

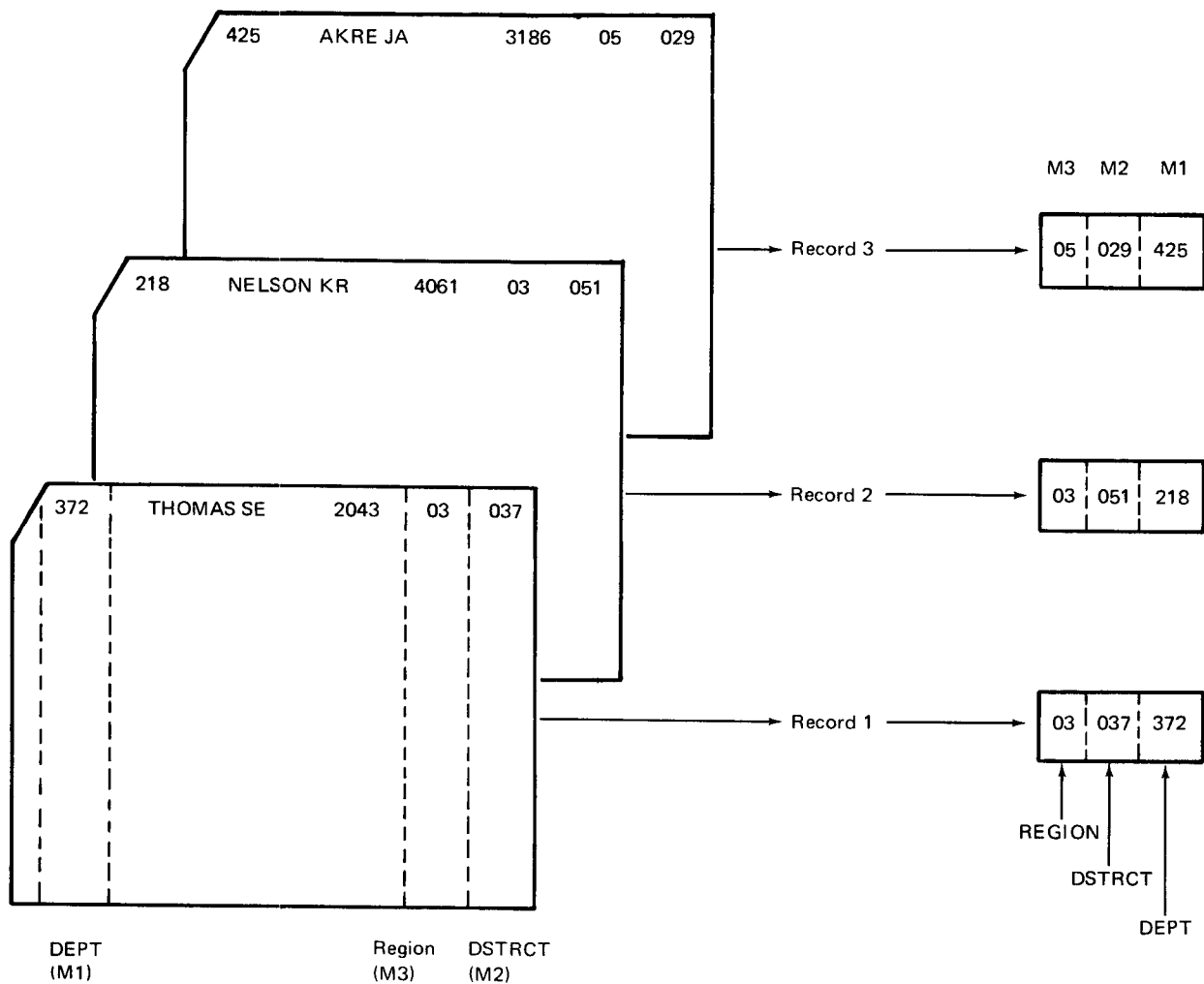

Figure 6-4. Match Fields Checked According to Level Assigned

Processing halts when the first record out of sequence is read. You can then correct the order of the records to continue processing. Note, however, that only an error in the direction of the sequence is detected. When sequence checking a file with match fields, RPG II does not cause the processing to stop when a duplicate match field is read. This can be accomplished, however, by coding the sequence check using calculation specifications.

In the last example, all records in the EMPLOYEE file were the same record type; that is, they contained the same type of information in the same location on each record. Therefore, a particular match field could always be found in certain positions for every record in the file.



For this particular program, you want a list of all employees, in ascending sequence according to district. Furthermore, the records within a district are to be in sequence according to department and employee numbers. To ensure the sequence of the file, three fields on each record must be checked, as shown in Figure 6-6. DISTRCT is the most important category and, therefore, is assigned the highest match field entry.

Since there are two different record types, a particular match field may not always be in the same record positions. For instance, DISTRCT is in positions 15-16 on salesman records, and in positions 20-21 on records for other employees. You must tell the program where to locate the match fields for each record type (Figure 6-7). Once the program determines the record type by checking the code in position 96, it then looks at the appropriate match field positions for that record type.

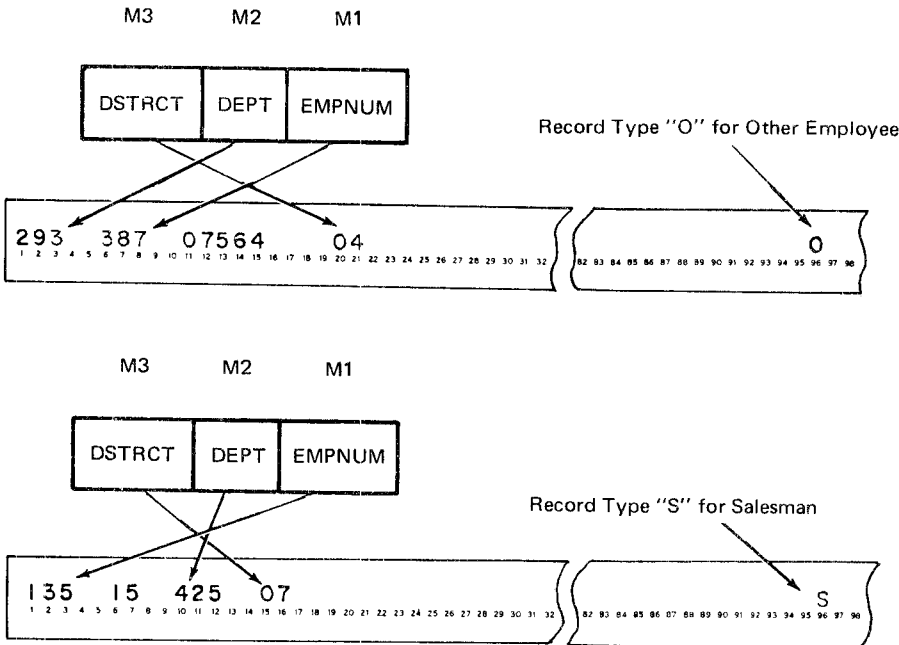

Figure 6-6. Match Fields in Different Locations on Two Records

IBM International Business Machine Corporation		RPG INPUT SPECIFICATIONS										GX21-9094 U/M 050*		Printed in U.S.A.				
Program		Punching Instruction		Graphic		Card Electro Number		Page 1 of 2		Program Identification		75 76 77 78 79 80						
Line	Form Type	Filename	Sequence	Number (LN) Option (O)	Record Identifying Indicator	Record Identification Codes			Field Location		Field Name	Control Level (L1-L9)	Matching Fields or Chaining Fields	Field Record Relation	Field Indicators			
						Position	Not (N) C/Z/D Character	Position	Not (N) C/Z/D Character	Position					Not (N) C/Z/D Character	From	To	Plus
01	I	EMPLOYEEAA	01			96	CS											
02	I																	
03	I																	
04	I																	
05	I																	
06	I	BB	02			96	CO											
07	I																	
08	I																	
09	I																	
10	I																	

Figure 6-7. Assigning Match Fields to Different Record Types



Fields from different record types which have been assigned the same match value may have the same name. As shown in Figure 6-7, M2 has been assigned both to the DEPT field on salesman records and to the DEPT field on other employee records.

If match fields are assigned to more than one record type in a program, all of the records (with match fields) must be assigned the same number of match fields. Furthermore, all match fields (on different record types) which are given the same value (M1-M9) must be the same length. Thus, all M1 fields must be the same length, all M2 fields must be the same length, and so on. This, of course, means that the total length of the match fields must be the same for each of the records.

In this example, the EMPLOYEE file contains only two types of records and both are assigned match field entries. However, match fields need not be specified for all record types in a file. Record types which do not contain match fields are processed in the order they are read. The sequence check, then applies only to the record types to which match field entries have been assigned.

### USING MATCH FIELDS WITH FIELD-RECORD RELATION FOR MORE THAN ONE RECORD TYPE IN A FILE

In the last example, each of the record types in the EMPLOYEE file is described with a separate set of input specifications. Since all of the fields to be used for matching are in different columns on the different record types, the same match field entries are assigned once for each record type.

### Match Fields the Same for All Record Types

Often, however, you may find that although there are different record types in a file, many of the fields are the same on all record types. That is, many fields have the same name, contain the same type of data, and are always found in particular positions of any record type in the file. For example, salesmen records and other employee records might be organized as shown in Figure 6-8. For both record types, all fields are the same except the COMM and SALARY fields and the record identifying code in position 96.

When only a few fields differ, record types can be described on the Input sheet in an OR relationship. Instead of using separate sets of input specifications, common fields need to be described only once. As shown in Figure 6-9, entries under Field Record Relation (columns 63-64) can then identify the fields which are unique to a particular record type. Notice that fields which are the same for all record types are described first. All fields related to a particular record type are then described before specifying the fields related to one of the other record types.

DSTRCT, DEPT, and EMPNUM are the three match fields to be used in sequence checking the EMPLOYEE file.

Since they are described only once on the Input sheet without any field record relation entries, the match field entries also need to be assigned only once (Figure 6-9). When record types are described in an OR relationship and a match field entry is assigned to a field without any field record relation entry, the match field will be used for all record types.

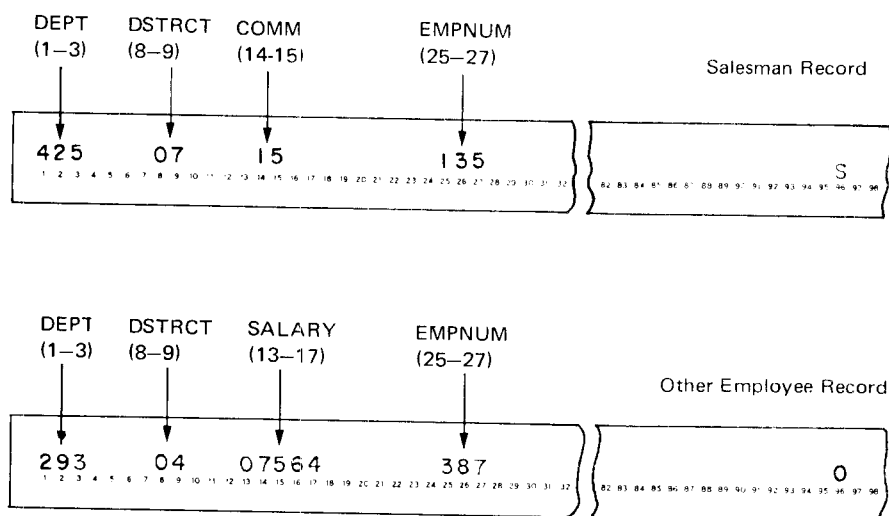

Figure 6-8. Same Match Fields for Both Record Types



According to what you have learned so far, you might assign match field entries as shown in Figure 6-11.

(positions 12-14) on whichever record type was read. Of course, the M2 match field is not in positions 12-14 on either record type so you don't want this incorrect data to be used in sequence checking. It won't be, because *all of the match field entries are checked before the sequence checking is performed*. If the record read is record type 01, line 07 is performed. This entry tells the program that the data in positions 10-12 should be used for the M2 field. On the other hand, if record type 02 is read, line 08 is performed and the data in positions 5-7 is used instead of that in positions 12-14. Actually, then, when either of the specifications in lines 07 or 08 is performed (depending on record type), the data used as the match field is changed, as if the dummy entry had never been specified.

Although the specifications in Figure 6-12 will cause the EMPLOYEE file to be sequence checked correctly, there is a way to reduce the number of specifications required. As mentioned, for a dummy entry you can specify any record positions which give the correct length for the match field. However, if you specify the actual positions associated with that match field on one of the record types, there is no need for the specification which relates those positions to the match field for that record type (Figure 6-13). Thus, by entering 10 to 12 (line 05, Figure 6-13) as the positions for the M2 field, you can eliminate the match field entry (line 07) in which the M2 field is described for record type 01.

However, the specifications shown in Figure 6-11 will *not* work. There is an additional rule to remember in assigning match field entries when field-record relation is used and the match fields differ between record types. If one (or more) of the match fields in either file is assigned without a field-record relation, the rest of the match fields must be assigned in the same way, without entries in columns 63-64. Of course, the specifications which assign some of these match fields with field-record relation are still necessary. Notice in Figure 6-11 that two of the match fields (M1 and M3) are associated with all record types (without field-record relation entries). Therefore, an additional entry (dummy entry) should be made (see line 05 of Figure 6-12) to assign the M2 match field (DEPT) to all record types also.

Actually the M2 match field isn't the same for all record types, since the location of the field varies. Therefore, how do you know which entries to make in the Field Location columns of this dummy match field entry? You know that any one match field is always the same length, regardless of record type or location in the record. In this case, DEPT is three positions long. Any numbers which give the correct length of the match field can be specified as Field Location.

As shown in Figure 6-12, positions 12-14 are specified for the dummy match field. When this specification line is performed, the program looks at the three positions of data

I		EMPLOYEE		OR		01		02		96		CS		CC		1		2		3		From		To		Field Name		Control Level (L+L8)		Matching Fields or Chaining Fields		Field Record Relation		Field Indicators	
Line	Form Type	File	Record	Sequence	Number (1-9)	Option (0)	Position	Not (N)	Character	Position	Not (N)	Character	Position	Not (N)	Character	Start/Stop	P/B/L/R	From	To	Decimal Positions	Field Name	Control Level (L+L8)	Matching Fields or Chaining Fields	Field Record Relation	Plus	Minus	Zero or Blank								
01	I	EMPLOYEE	AA	01	96	CS												1	3		EMPNUM	M1													
02	I	EMPLOYEE	OR	02	96	CC												20	21		DSTRCT	M3													
03	I																	6	7		COMM		01												
04	I																	10	12		DEPT	M201													
05	I																	5	7		DEPT	M202													
06	I																	10	14		SALARY		02												
07	I																																		
08	I																																		
09	I																																		

These specifications are incorrect.

Figure 6-11. Incorrect Match Field Entries for Records Described with Field Record Relation

**IBM** International Business Machine Corporation

## RPG INPUT SPECIFICATIONS

GX21-9094 U/M 050\*  
Printed in U.S.A.

Program \_\_\_\_\_ Card Electro Number \_\_\_\_\_  
 Programmer \_\_\_\_\_ Date \_\_\_\_\_ Punching Instruction \_\_\_\_\_ Graphic \_\_\_\_\_  
 Punch \_\_\_\_\_

Page 1 2 of \_\_\_\_\_ Program Identification 75 76 77 78 79 80

Line	Form Type	Filename	Sequence Number [1-N] Option [O]	Record Identifying Indicator or *	Record Identification Codes									Field Location		Field Name	Control Level [1-L9] Matching Fields or Chaining Fields	Field Record Relation	Field Indicators					
					1			2			3			From	To				Plus	Minus	Zero or Blank			
					Position	Not [N] C/Z/D	Character	Position	Not [N] C/Z/D	Character	Position	Not [N] C/Z/D	Character											
01	I	EMPLOYEEA	AA	01	96			CS																
02	I	OR		02	96			CO																
03	I													1	3	EMPNUM	ML							
04	I													20	21	DSTRCT	M3							
05	I													12	14	DEPT	M2							
06	I													6	72	COMM	01							
07	I													10	12	DEPT	M201							
08	I													5	7	DEPT	M202							
09	I													10	142	SALARY	02							

Performing either of these specifications actually voids what has been done as a result of performing the dummy entry.

Dummy entry so that all match fields are assigned without field-record relation.

Figure 6-12. Assigning Match Fields for Records Described With Field Record Relation

**IBM** International Business Machine Corporation

## RPG INPUT SPECIFICATIONS

GX21-9094 U/M 050\*  
Printed in U.S.A.

Program \_\_\_\_\_ Card Electro Number \_\_\_\_\_  
 Programmer \_\_\_\_\_ Date \_\_\_\_\_ Punching Instruction \_\_\_\_\_ Graphic \_\_\_\_\_  
 Punch \_\_\_\_\_

Page 1 2 of \_\_\_\_\_ Program Identification 75 76 77 78 79 80

Line	Form Type	Filename	Sequence Number [1-N] Option [O]	Record Identifying Indicator or *	Record Identification Codes									Field Location		Field Name	Control Level [1-L9] Matching Fields or Chaining Fields	Field Record Relation	Field Indicators					
					1			2			3			From	To				Plus	Minus	Zero or Blank			
					Position	Not [N] C/Z/D	Character	Position	Not [N] C/Z/D	Character	Position	Not [N] C/Z/D	Character											
01	I	EMPLOYEEA	AA	01	96			CS																
02	I	OR		02	96			CO																
03	I													1	3	EMANUM	ML							
04	I													20	21	DSTRCT	M3							
05	I													10	12	DEPT	M2							
06	I													6	72	COMM	01							
07	I													10	12	DEPT	M201							
08	I													5	7	DEPT	M202							
09	I													10	142	SALARY	02							

This entry eliminated since the dummy entry specifies the match field is in positions 10-12.

Dummy entry so that all match fields are assigned without field-record relation.

Figure 6-13. Eliminating Specifications in Assigning Match Field Entries

After performing the dummy entry (line 05), the program knows the M2 match field is to be found in positions 10-12. If record type 01 is read, the M2 field actually is in positions 10-12. Thus, line 07 doesn't have to be performed, since it does not change anything. Of course, if record type 02 is read, the specification in line 08 is performed. This says, for record type 02, use positions 5-7 for the M2 field instead of positions 10-12.

The field name specified for the dummy entry can be any name, since field names are ignored in selecting match fields. In this case, DEPT was specified since it happens that the M2 fields on both record types have the same name. If the names to be used differ, it is still a good practice to use a name given to the match field on one of the record types.

### **MATCHING RECORDS: ONE RECORD TYPE IN EACH FILE**

One of the most common forms of multfile processing involves using one file to obtain data from another file. Figure 6-14 shows a weekly sales report to be printed which is used to determine which items are selling best at which location. A SALES file contains records of individual items sold, giving the quantity and location. The description of each item, however, must be obtained from an ITEM master file. The ITEM master file consists of one ITEM record for each item in stock.

For this program, let's assume that each file contains only one record type. All ITEM records are in one format and are identified by the character I in position 1. All records in the SALES file are identified by an S in position 1 and are also in one format (certain type of information in same location on every record). The SALES records for a particular item can be associated with the related ITEM master record by a common match field containing the item number (see Figure 6-14).

### **Processing Order: More Than One Matching Record in a Secondary File**

In the ITEM master file, there is only one record for each item, but in a program run there may be several SALES records for that particular item. Let us suppose there is always at least one SALES record for each ITEM record. Therefore, there should be no records in either file which do not have a matching record in the other file. Both files are specified with match fields in ascending sequence.

To produce the report in Figure 6-14, in what order should records from the two files be processed? First an ITEM master record should be processed; that is, the item number and description printed. Then, all the SALES records which are for the same item (match fields the same) should be processed. The quantity and location of each sale should be printed under description. Thus, after every ITEM record processed, one or more SALES records must be processed before the next record from the ITEM master file is processed.

How does RPG II know when to stop printing SALES records and to process the next ITEM? As we said, the SALES records for a particular item are read one at a time and printed. When the match field on a SALES record is for a different item, that SALES record is not processed immediately. Instead, the next ITEM master record is processed to print the description for the new item. Then the SALES records for that item are printed. As you can see, to determine the correct order of processing, both files must be in the same sequence according to the match field; in this case, in ascending sequence by item number.

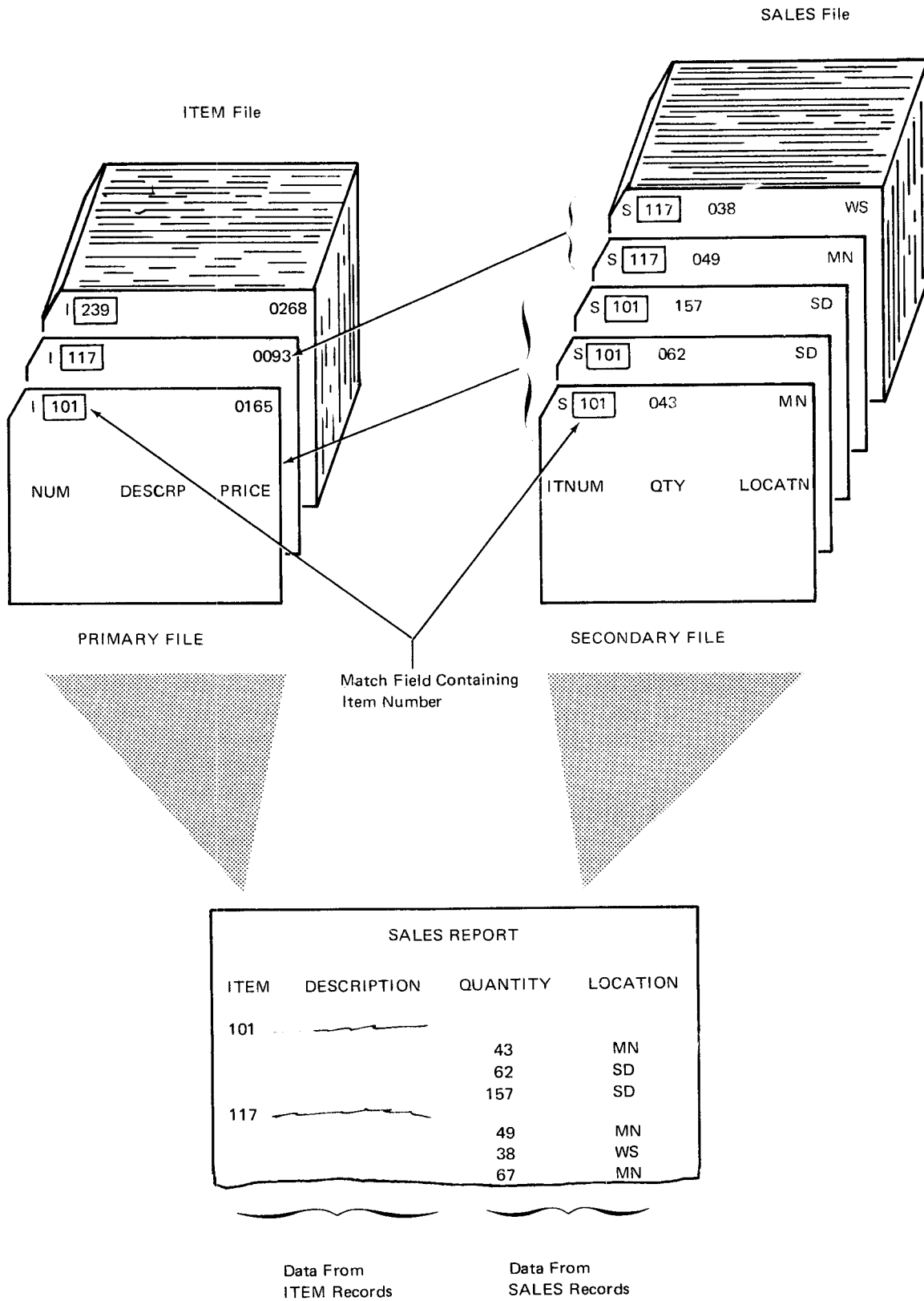

Figure 6-14. Matching SALES Records with Related ITEM Records to Produce a Printed Report

## How RPG II Logic Determines From Which File to Process a Record

Using the same example, let's see how the RPG II logic determines from which file a record is to be processed. The ITEM master records are the primary file and the SALES records are the secondary file. When two input files are used in a program, the program cycle is slightly different for the first record read. You can follow the logic flow shown in Figure 6-15 as we discuss the first program cycle and subsequent cycles for this job. Pay special attention to when the record identifying indicator is on, identifying the record to be processed, and when the MR indicator is turned on and off.

At the beginning of the first program cycle (Figure 6-15, part A), a record is read from each file. The first step is to determine which record to process. The program determines if match fields are specified for both record types. In this case, both the ITEM record and the SALES record contain an M1 field. The match fields from each file are then compared to see which is lower in sequence. (If the file had been in descending sequence, the program would check for the highest match field.) In this case, neither field is lower as the match fields on the primary and secondary records are both 101. When match fields from the two files are the same, the record from the primary file is always selected for processing.

Now the appropriate record identifying indicator is turned on to identify the type of record selected for processing. Thus, 01 would be turned on for the ITEM record from the primary file.

Once a record is selected for processing and the record identifying indicator is turned on, the program determines whether the MR indicator should be on during processing of the record. Since the match fields are equal (both 101), a matching record condition exists. The MR indicator is not turned on yet, however, because the selected record is not ready to be processed yet.

First, the program checks to see if any total operations are to be performed for previously processed records. Total calculations and total output are performed only if control fields change or if the last record in the file has already been processed (LR on). Since there are no control fields in either file, control level indicators will never be turned on during this program. Furthermore, this is not the last record. Neither condition has occurred; therefore, total-time operations are bypassed.

At this point, the MR indicator is turned on to indicate that the matching record condition exists. Now the program is ready to perform the detail operations for the record which was selected for processing. Thus, the item number and description from the primary file record are printed. The program knows which operations are to be performed because the operations are either conditioned to be performed only when record identifying indicator 01 and the MR indicator are on or they are not conditioned by indicators.

Once the processing of this record is completed, the record identifying indicator is turned off (01 off). This completes the first program cycle; that is, one record has been processed.

For the processing of all subsequent records, look at the program cycle in Figure 6-15, part B. The entire cycle will be repeated for each record processed.

At the beginning of the first cycle, a record was read from both the primary file and the secondary file. However, since only one record is selected for processing at a time, one record (in this case, a SALES record) still remains in the input read area. Therefore, a record from only one file is read at the beginning of the second cycle and for all following program cycles. The record read will be from the same file as the last record processed. Thus, for the second cycle, the second record from the ITEM file would be read into the primary file read area.

Now that a record from each file is in the read area again, the second record can be selected for processing. Once again the first step in the logic is to determine if match fields are specified for the records from both files. In this program, there is only one record type per file and both are assigned match fields. Therefore, the answer to this question is yes for every program cycle of this program.

The match fields from both records are then compared. In this case, the secondary file SALES record is for the first item number (101). Since the ITEM record for the first item (101) has already been processed, the primary file record in the read area is for the second item number (117). The match field on the SALES record is lower in sequence than the match field on the ITEM record; therefore, the SALES record is selected to be processed. Once again, a record identifying indicator (02 for a SALES record) is turned on to identify the type of record selected.

At this point, the MR indicator is still *on* because the previous comparison (item 101) did give a match. The setting of MR has nothing to do with the record which was just selected for processing. The indicator will not be set to reflect the current condition until just before the record selected for processing (SALES record for item 101) is processed.

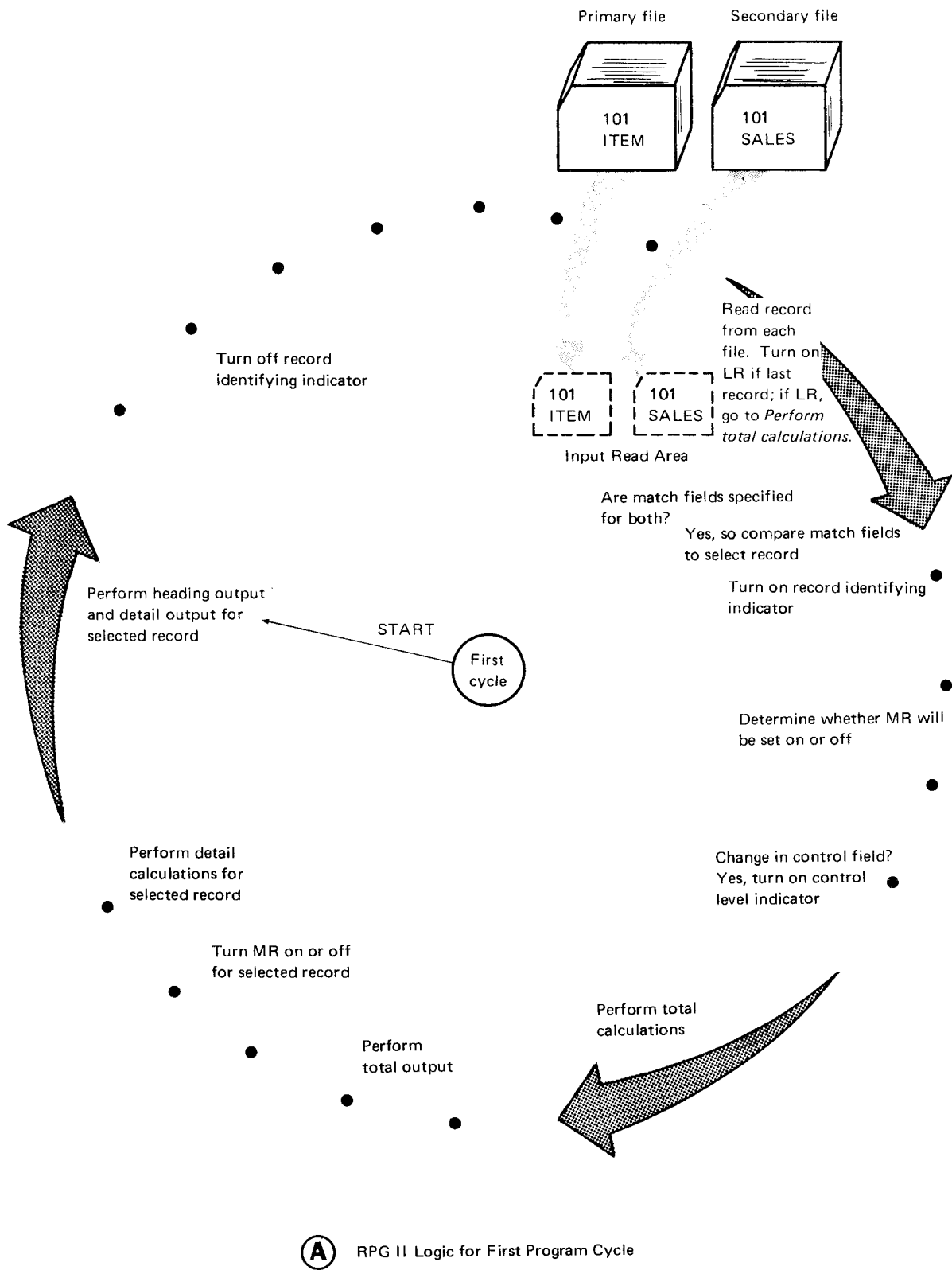
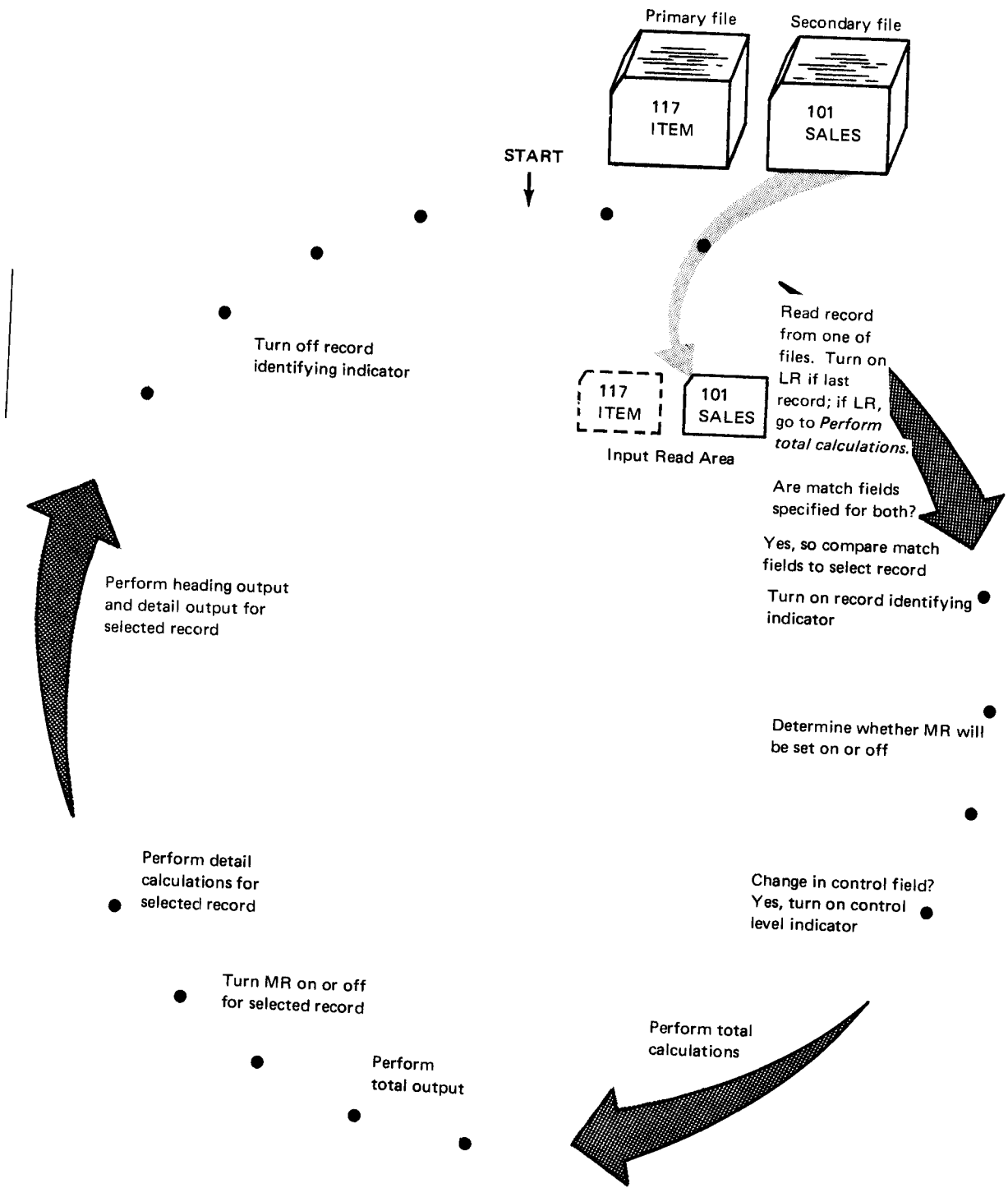

Figure 6-15 (Part 1 of 2). Logic of Matching Records





**(B)** RPG II Logic for Subsequent Program Cycles

Figure 6-15 (Part 2 of 2). Logic of Matching Records



### RPG INPUT SPECIFICATIONS

Program		Punching Instruction		Graphic Punch		Card Electro Number		Page 1 2 of		Program Identification 75 76 77 78 79 80																	
Line	Form Type	Filename	Sequence	Record Identifying Indicator	Record Identification Codes			Field Location		Field Name	Control Level (L1-L9)	Matching Fields or Chaining Fields	Field Record Relation	Field Indicators													
					Position	Not (N)	C/Z/D	Character	Position	Not (N)	C/Z/D	Character	Position	Not (N)	C/Z/D	Character	Stacker Select	P/B/L/R	From	To	Decimal Positions	Plus	Minus	Zero or Blank			
01	I	ITEM	AA	01	1			CI											2	6	40NUM						
02	I																		6	23	20DESCR	ML					
03	I																										
04	I																										
05	I	SALES	BB	02	1			CS											3	8	50ITNUM	ML					
06	I																		8	15	100QTY						
07	I																										
08	I																										

One record type in each file.

Match field in each file containing item number.

### RPG OUTPUT SPECIFICATIONS

Program		Punching Instruction		Graphic Punch		Card Electro Number		Page 1 2 of		Program Identification 75 76 77 78 79 80							
Line	Form Type	Filename	Type (H/D/T/E)	Stacker # / Franchise	Space	Skip	Output Indicators			Field Name	End Position in Output Record	P/B/L/R	Commas Zero Balances to Print No Sign CR - X - Remove Plus Sign Date Field Edit Zero Suppress				
							And	And	And				Constant or Edit Word				
01	O	REPORT	H			306				*AUTO							
02	O		OR														
03	O																
04	O																
05	O		D	L						NUM	6		Printing data from ITEM record.				
06	O									DESCR	31						
07	O																
08	O		D	L						QTY	44		Printing data from SALES record.				
09	O									LOCATN	60						
10	O																
11	O																
12	O																
13	O																
14	O																
15	O																
16	O																
17	O																
18	O																
19	O																
20	O																

Report that will be printed.

ITEM	DESCRIPTION	QUANTITY	LOCATION
101		43	MN
		62	SD
		157	SD
117		49	MN
		38	WS
		67	MN

Figure 6-16 (Part 2 of 2). Specifications for Matching Records Program

File description specifications also associate each input file with a particular device. On the MFCU, the primary file is usually entered through the primary hopper (device entry MFCU1); the secondary file is usually read from the secondary hopper (device entry MFCU2). However, in multi-file processing using the MFCU, either file may be associated with either of the two hoppers.

The contents of the two input files are described on the Input sheet, with a separate set of specifications for each file. Entries in columns 19-27 identify the two record types. Record identifying indicator 01 will turn on if an ITEM record is selected for processing; indicator 02 will turn on if a SALES record is selected. The single match field in each file is specified by assigning the M1 entry in columns 61-62, as you learned previously.

Lines 01-04 of the Output sheet specify that headings are to be printed at the top of every page of the report.

As you recall in the discussion of matching record logic, the 01 record identifying indicator is on whenever an ITEM record is being processed. Furthermore, ITEM records are processed only if a matching record condition exists (MR on). Therefore, conditioning the printing of the item number and description by MR and 01 ensures that the information is coming from the ITEM record.

The quantity and location are to be printed only when a SALES record is being processed. Because the MR indicator is on during the processing of both ITEM records and SALES records, it isn't sufficient to condition this output line only on the basis of MR. Therefore, the printing of quantity and location is conditioned by both the MR indicator and the 02 record identifying indicator.

In this case, calculation specifications are not required. However, if calculations are required and are to be performed only if a matching (or not matching) record condition exists, calculations must also be conditioned by the MR (or NMR) indicator.

### Processing Order: More Than One Matching Record in the Primary File

For the example just presented, there was more than one record in the secondary file with the same match field. That is, a single ITEM record was related to a number of SALES records. In such a case, the order of processing was the first primary file record, followed by its related secondary file records, then the next primary file record, followed by its related secondary file records, and so on.

Let's take a look at another set of files, in which each record has a matching record in the other file. Figure 6-17, part A, shows that there may be more than one primary file record which matches the same secondary records. In what order do you think these records would be processed? The first primary file record processed would not necessarily be followed by its related secondary file records. Instead, all primary file records with the same match field AA would be processed; then all secondary file records for AA (see Figure 6-17, part B).

Actually, the RPG II logic used to determine the order in which such files are processed is the same as that discussed previously. Remember that whenever the match fields on the two records in the read area are the same, the primary file record is always selected for processing. Thus, during the first program cycle, the first primary file record (AA) is compared to the first secondary file record (AA). The match fields are the same, so the first primary file record is processed. Then the second primary file record (again AA) is read and compared to the first secondary file record (AA), still in the read area. Since there is a match again, this second primary file record is processed.

For both of the last two examples presented, every record in the secondary file had at least one or more related records in the primary file. Since a matching record condition always exists, the MR indicator was on during the processing of every record in both files.

### Matching Records: Records Which Have No Match in the Other File

In the multiframe programs presented, there was at least one SALES record for every ITEM master record. Therefore, all records had a related record in the other file. Of course, in multiframe processing, it is possible to have primary file records with no related records in the secondary file, as well as secondary file records with no related primary file records. In either case, the record with no related record in the other file is called an *unmatched record*. For instance, if only certain items are sold, there would be an ITEM master record for every item and SALES records for only some of those items. The ITEM records for which no sales were made would be unmatched records.

Unmatched records can be in either or both files, but they are usually found in the primary file. In this example, it is quite probable that for any one item, no sales have taken place. However, it is not as likely that sales have occurred for an item for which there is no record in the ITEM master file.

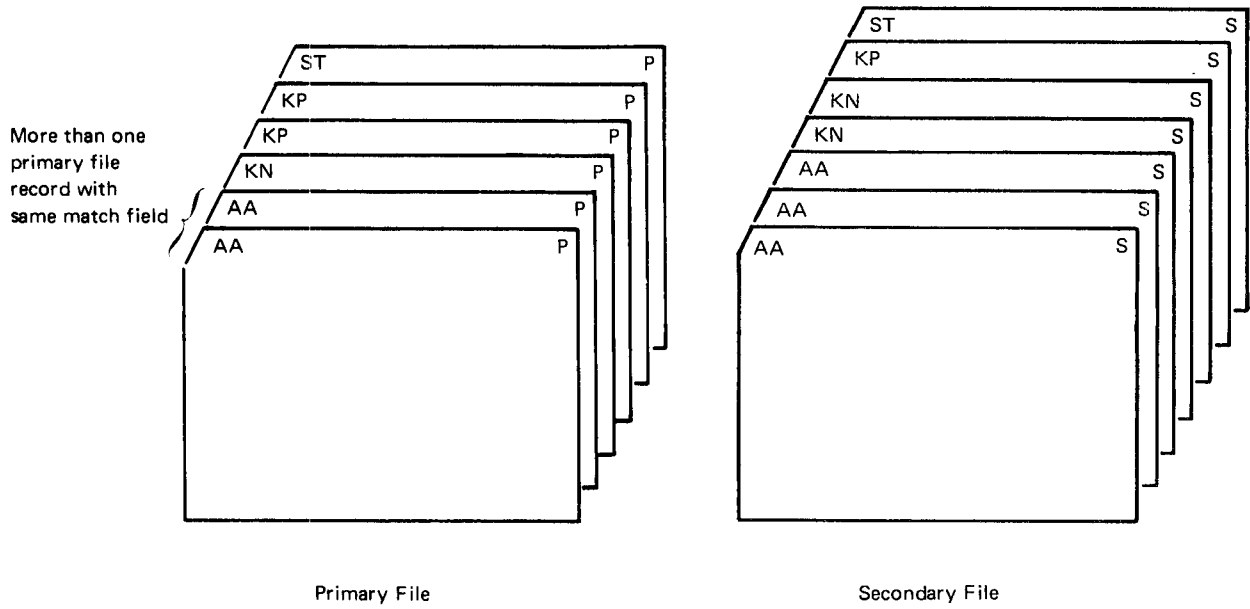

**A** FILES BEFORE PROCESSING

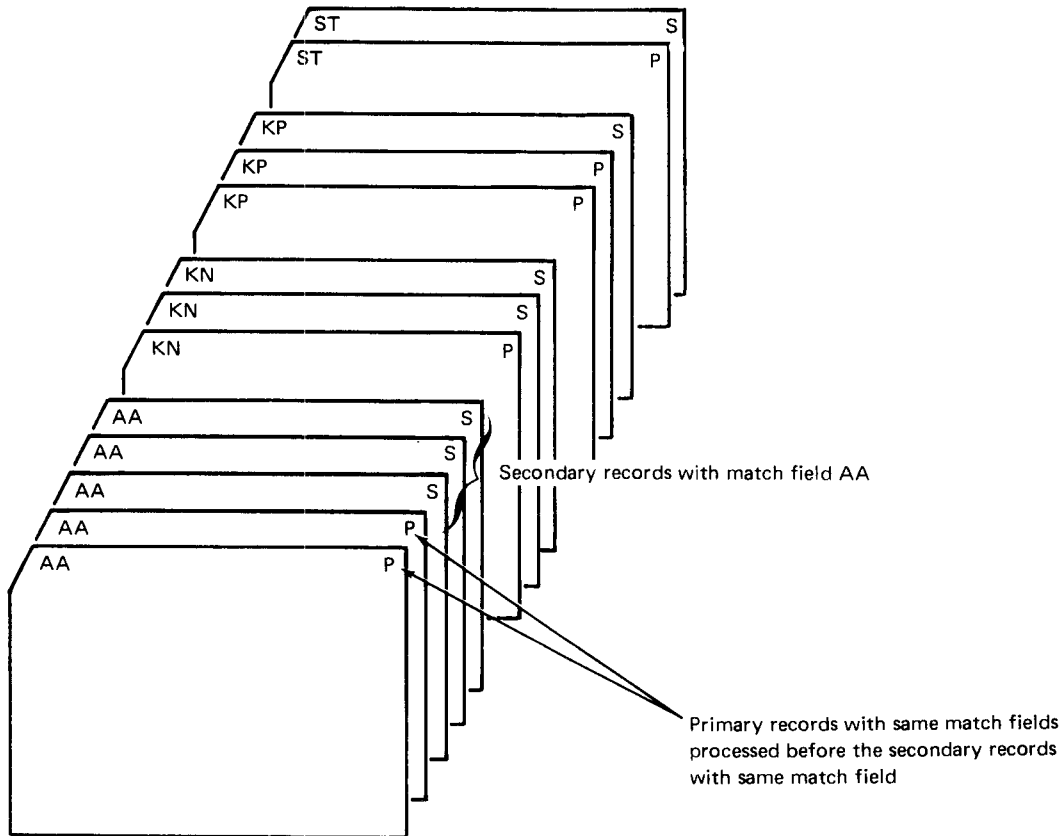

**B** ORDER OF PROCESSING THE FILES

Figure 6-17. More than One Primary File Record with Same Match Field

### *Processing Order: Unmatched Records*

Let's assume that the two files for this program consisted of the records shown in Figure 6-18, part A, with the primary file containing two unmatched records. The RPG II logic related to matching records would determine the order in which to process the records (Figure 6-18, part B). As explained earlier, first the ITEM master record for item 101 is processed, followed by all SALES records for item 101. Remember, if a record is selected for processing during a program cycle, the next record from that same file is read at the beginning of the next cycle. Therefore, when the first SALES record for item 117 is read, another matching record condition exists. Thus, the primary file record (ITEM record for item 117) is processed first. The next primary file record for item 124 is then read to replace the ITEM record processed. Since SALES records with match fields of 117 are lower in sequence than 124, the two SALES records for item 117 are processed. Furthermore, although the match fields (117) on the SALES records are not the same as that of the ITEM record in the read area (124), they are the same as the match field of the last ITEM record processed. Therefore, the MR indicator is on when each SALES record for 117 is processed.

When the next SALES record (item 239) is read, there still isn't a match with the ITEM record for 124. The match field on the ITEM record is lower than that on the SALES record; therefore, the primary file record for item 124, an unmatched record, is processed first (Figure 6-18, part B). Since the files are in ascending sequence, this means that there is no record in the secondary file with a match field of 124. Therefore, MR will be turned off just before the ITEM record for 124 is processed.

This program cycle shows that even if there is no matching record condition, the primary file may be selected for processing. This is because RPG II logic looks for the record with the lowest match field, regardless of whether the record is from the primary file or the secondary file.

Now the next primary file ITEM record (239) is read. Since it matches the SALES record in the read area, the primary file record is automatically selected for processing. Although a matching record condition exists for the ITEM record selected, at this point the MR indicator is still off because of the last record processed (unmatched ITEM record for 124). The status of MR is not changed until right before detail operations for the selected record are performed.

Following the ITEM record for 239, the SALES record for item 239 is processed. Then, as before, the unmatched ITEM record for item 286 is processed, since it is lower in sequence than item 321 on the next SALES record. To complete the processing, the primary file ITEM record for item 321 is processed, followed by the two sales records for item 321.

In summary, then, RPG II sets the MR indicator to off immediately before processing any unmatched records. MR is turned on before processing a record that has a matching record in the other file. After a record has been processed, the indicator remains as it was until it is set again immediately before the next record is processed.

Regardless of the records in a file, there is an easy way to determine if a matching record condition exists and if the MR indicator will be turned on:

1. When a primary file record is selected for processing, MR will be turned on if there is a secondary file record in the read area with the same match field.
2. When a secondary file record is selected for processing, MR will be turned on if the last primary file record processed had the same match field.

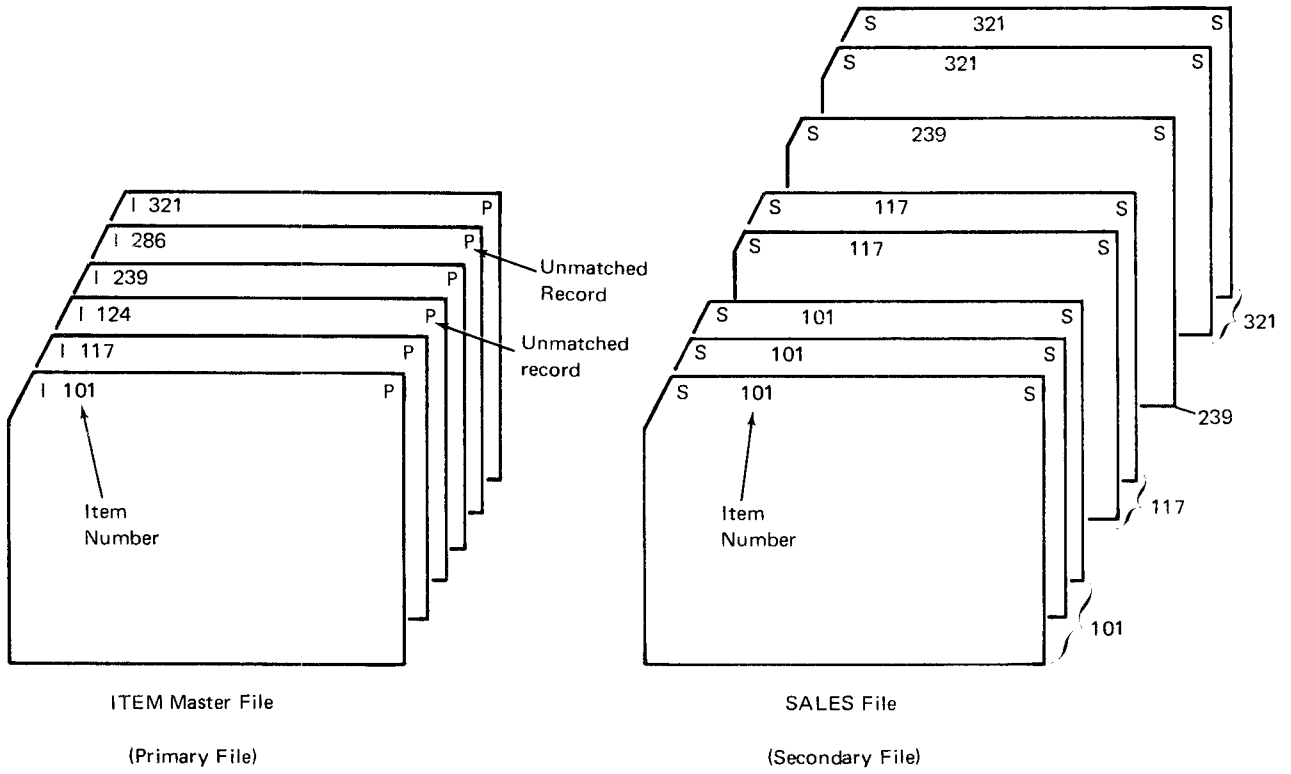

**A** FILES BEFORE PROCESSING

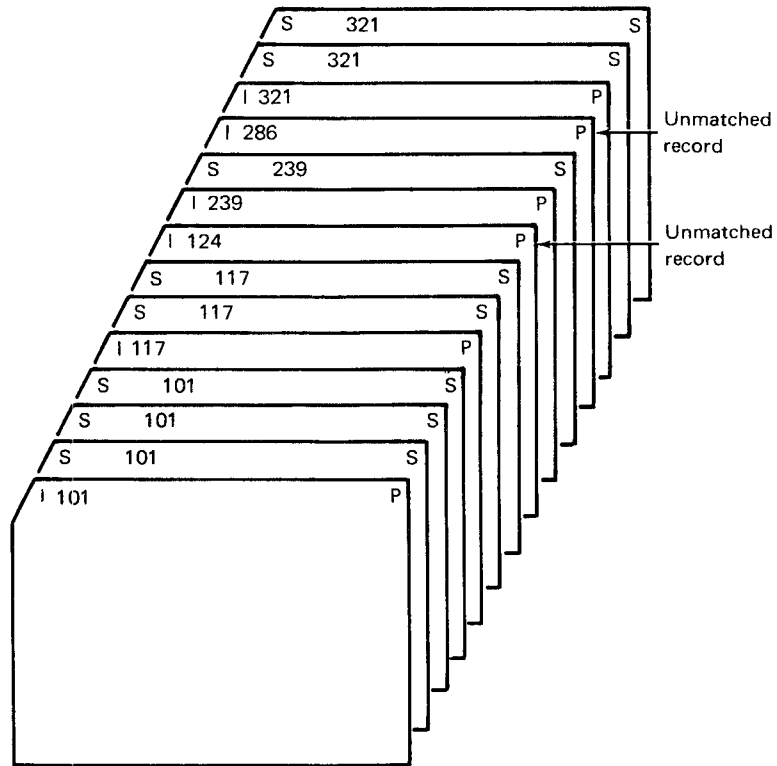

**B** PROCESSING ORDER OF FILES

Figure 6-18. Processing Files with Unmatched Records



### Stacker Selection of Unmatched Card Records

When records from two files are assigned match fields, a record from one file may be processed, then a record from the other file, and then a record from the first file again. However, regardless of the order in which the records are processed, all cards which enter through the primary hopper of the MFCU or MFCM are automatically stacked in stacker 1. All cards entering through the secondary hopper end up in stacker 4 (stacker 5 on the MFCM Model A1).

If there are unmatched records in either file, you can separate such cards from the others in that file by stacker selecting the unmatched cards into a different stacker. As you learned in the chapter *Card Output Operations*, cards from an input file can be selected into a different stacker by entering the number of the stacker on the Input sheet. However, this can be done only when input cards are to be stacker selected on the basis of record type.

Stacker selection of a card because it has no matching record in the related file must be specified in column 16 of the Output sheet (Figure 6-19, part A). However, an input file cannot be specified on the Output sheet. Therefore, the input file containing the card to be stacker selected (the card with no related record) must be defined as a combined file on the File Description sheet (Figure 6-19, part B). The combined file name can then be used on the Output sheet for stacker selection.

Notice on the Output sheet that stacker selection is specified for the combined file ITEM (line 11), since only the ITEM file contains unmatched records. The filename indicates from which file the cards will be output. Since a matching record condition cannot possibly exist for any unmatched records, MR must be off. Therefore, the stacker selection of records is conditioned by NMR (off).

Any record, conditioned for stacker selection by the MR indicator, should be specified as a detail-time record (see Figure 6-19, part A, column 15). Otherwise, the next record to be processed would be stacker selected instead of the record you want. This is because the detail-time processing of a card is done within one program cycle and the processed record automatically passes into the normal output stacker, if not stacker selected. The total-time operations for that same record are not performed until the next program cycle, after another record has been selected for processing. During total-time operations, although the status of the MR indicator is still set for the previously processed record, the only record available to be stacker selected is the card just selected for processing.

Whenever you wish to have a certain type of output based on a matching or not matching record condition, it can be important that a record identifying indicator be used with MR or NMR to condition the output. The record identifying indicator determines from which record type the information will be punched, stacker selected, or printed. For the printer output file, output can come from either the SALES file or the ITEM file (Figure 6-19, part A). Therefore, record identifying indicator 01 or 02 is specified to indicate which record type is to be printed (lines 05 and 08). Record identifying indicator 01 is entered on line 11 in addition to NMR so that stacker selection will occur for the ITEM file only when an ITEM record has been processed.



## MATCHING RECORDS: MORE THAN ONE RECORD TYPE IN A FILE

### Match Fields in Different Locations in the Same File

Let's consider again the specifications necessary in assigning match fields for the weekly sales report. This time, however, suppose the SALES file used in producing the report contains two record types, charge records and cash records (see Figure 6-20). Both record types contain the item number, quantity, and location. In addition, charge records contain an account number, which cash records do not have. The cash sales records are identified by a C and an S in positions 1 and 2. Charge sales records contain an S in position 2, but no C in position 1. Furthermore, the match fields are in different locations on the two types of SALES records.

Recall the discussion of assigning the match fields for sequence checking within a file (see *Checking Sequence of Records Within a File*). When match fields are used in more than one record type in a file, the match field entries must

either be specified one for each record type or in a field-record relation. The way they are coded depends on whether the match fields are found in different locations on each record type. If match fields are in different record locations, they may be coded either way. However, the ease of coding separate specifications for each record type may be more important to you than the specifications and storage often saved by using field-record relation.

In assigning entries for match fields which are to be used for matching records from two files, the same considerations must be made. The only difference is that, for matching records, you are concerned with two files, rather than one. You know that the match field entries on the Input sheet must be assigned *separately for each file*. Then, if one of the files has more than one record type containing the match fields, the record types *in that file* can be described separately or with field-record relation. If you use field-record relation, just be sure a particular match field field entry applies to all of the appropriate record types within the file.

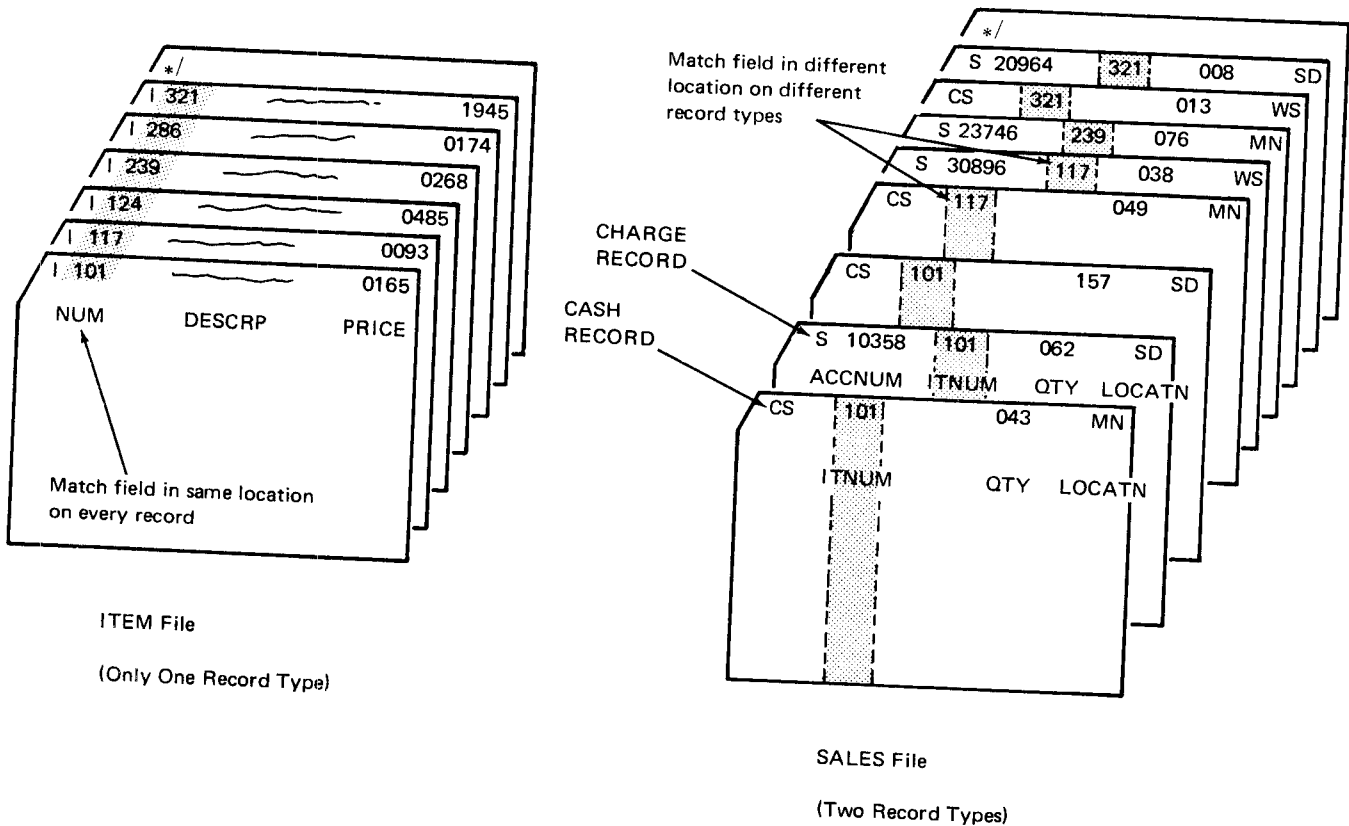

Figure 6-20. More than One Record Type in File Used for Matching

As shown in Figure 6-21, first the ITEM file is described as it was before (see Figure 6-16, part B). The M1 entry is assigned only once since there is only one record type in this file. The two record types in the SALES file have been described in an OR relationship, because most of the fields are in the same location on both types of SALES record. Note that all fields which are the same for both record types of the SALES file are specified first with no field-record relation entry. Then all the fields associated with the first type of SALES record only (02 for charge records) are specified, followed by those for the next record type (03 for cash records). The M1 entry must be assigned twice for the SALES file since the match field ITNUM is in different locations on the two record types.

For all records of the same record type, the match fields (as well as all other fields) must necessarily be in the same location for every record of that type. However, match fields may be in different locations within the same file, providing there is more than one record type.

Although there is more than one record type in the SALES file, the order in which the records are selected for processing would be the same as explained previously for only one record type in each file. Before a comparison of match fields can be made between files, RPG II must first determine what type of record was read so it knows where the match field is located on that record.

There are some important restrictions on the use of match fields for matching records between files. All records for which match fields are specified must contain the same number of match fields. This applies to both files, regardless of how many record types are in either file. In the sales report program, only one match field (item number) was used. However, just as for sequence checking, up to nine match fields may be used to match records between files.

In assigning match fields to records, remember that for matching purposes, RPG II considers all match fields of the same value (M1-M9) to be in the same format, numeric or alphanumeric. Thus, if any of the match fields are defined as being numeric, RPG II looks at only the digit portion of all the other match fields with the same M1-M9 value, even though some may be alphanumeric fields.

If more than one match field is assigned, all the match fields in a record from one file must be equal to all the match fields in the record from the other file before a matching record condition exists. For example, assume that M1, M2, and M3 are match fields assigned to records in two files. In comparing records from each file, if the M1 and M2 fields are the same, but the M3 fields differ, the records do not match. If the files were specified to be in ascending sequence, the record with the lower value match field (M3, M2, M1 combined) would be selected for processing.

IBM International Business Machine Corporation										RPG INPUT SPECIFICATIONS										GX21 9094 U.M.0507 Printed in U.S.A.									
Program										Punching Instruction										Card Electro Number									
Programmer										Date										Page 1 2 of Program Identification 75 76 77 78 79 80									
Line	Form Type	Filename	Sequence Number (1 NI)		Record Identifying Indicator or Character (01)	Record Identification Codes									Field Location			Field Name	Control Level (1 LCB)	Matching Fields or Character Fields	Field Record Relation	Field Indicators							
			Position	1		2	3	Position	1	2	3	Position	1	2	3	From	To					Decimal Positions	Plus	Minus	Zero or Blank				
01	I	ITEM	AA	01	1	CI											2	40	NUM	ML				Match field assigned once for item file.					
02	I																6	20	DESCRP										
03	I																23	26	PRICE										
04	I																												
05	I	SALES	BB	02	1	NC	2	CS									15	17	QTY					Charge records. Cash records.					
06	I		OR	03	1	CC	2	CS									21	22	LOCATN										
07	I																10	12	ITNUM	ML				Match field assigned for both record types of sales file.					
08	I																3	70	ACCNUM	02									
09	I																3	50	ITNUM	M103									

Figure 6-21. Describing Record Types and Assigning Match Fields for Two Files

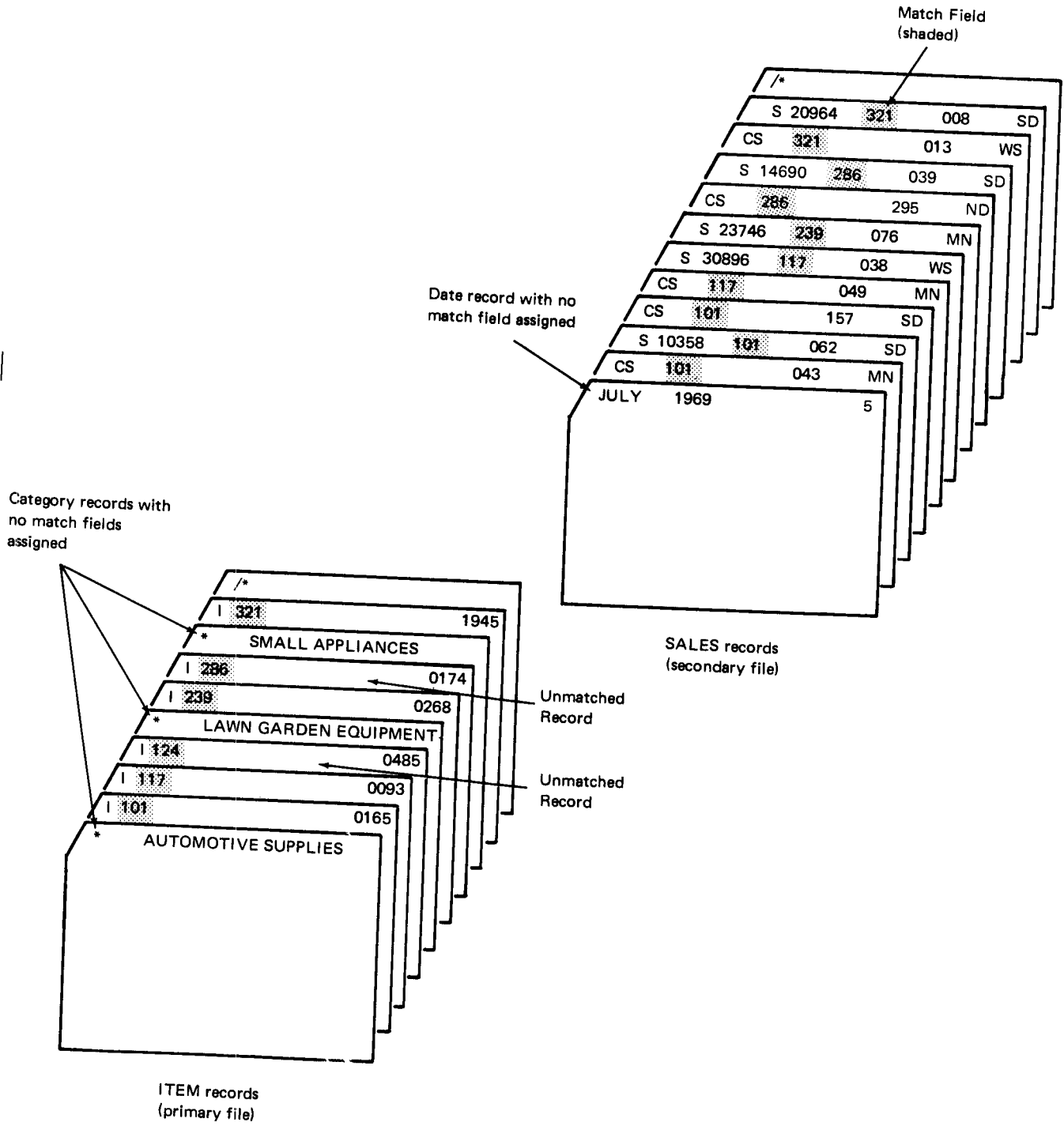

Figure 6-22. Files Containing Records Without Match Fields

**Processing Records Which Do Not Have Match Fields**

Up to now, all records in a file have been assigned match fields to be used in matching records from one file with those in the other file. Some files, however, may contain some records which are not to be matched; thus, such record types would not contain match fields.

As you recall, the ITEM file was organized in ascending sequence according to item number. Item numbers are assigned such that items can be grouped according to a general category. All items assigned numbers from 100-199 are automotive supplies, those from 200-299 are lawn and garden equipment, 300-399 are small household appliances, and so on. In addition to the ITEM records for each item, then, the ITEM master file contains a record preceding each group, identifying the general category to which the items belong (Figure 6-22). These category records are distinguished by an \* in position 1.

The SALES file also contains a record type which does not have a match field. In addition to the two types of sales records, one for cash sales and one for charge sales, there is a DATE record at the beginning of the SALES file, identified by 5 in position 96 (see Figure 6-22).

The two record types in the ITEM master file and the three record types in the SALES file would be described as shown in Figure 6-23. On the basis of the record identifying codes, one of the record identifying indicators which are assigned to the record types (positions 19-20) will turn on to indicate which record type was read.

Notice that the input specifications (Figure 6-23) assign a match field to only some of the record types present in the two files. The category records from the ITEM file and the date record from the SALES file are not to be matched with records from the other file.

Since match fields are used to determine the order in which records are processed, when will the category and date records be processed? Records for which no match fields are specified are processed immediately as they are read. To understand the order of processing and when the MR indicator is on, then, let's discuss how RPG II logic operates during the program cycles for this program.

Line		Form Type	Filename	Sequence		Record Identifying Indicator	Record Identification Codes						Field Location		Field Name		Field Indicators	
3	4	6	7-13	OR	AND	19-20	1	2	3	4	5	6	7	8	9	10	11	12
01	I		ITEM	AA	01		1	CI										
02	I													2	40	NUM	MI	Item records with match fields.
03	I													6	20	DESCRP		
04	I													23	26	PRICE		
05	I			AB	02		1	CK*						5	25	CATGRY		Category records.
06	I																	
07	I		SALES	BB	03		1	NCC	2	CS								Cash and charge sales records with match fields.
08	I			OR	04		1	CC	2	CS								
09	I													15	17	QTY		Date record.
10	I													21	22	LOCATN		
11	I													10	17	ITNUM	MI	
12	I													3	70	ACCNUM	03	Date record.
13	I													3	50	ITNUM	ML04	
14	I			BC	05		96	D5										
15	I													2	10	MONTH		Date record.
16	I													13	16	YEAR		

Figure 6-23. Describing Records With and Without Match Fields Assigned

At the beginning of the first program cycle, the first record is read from each file. RPG II then decides if match fields are specified for both records. As mentioned, a record for which no match fields are assigned is automatically selected for processing before the record in the other file.

In this case, neither record in the read area has match fields. Therefore, which should be processed? Without match fields, the two records cannot be compared to see which is lower in sequence. When both records do not have match fields, the record from the primary file has priority and, thus, is selected for processing.

Since match fields are not assigned to this record type, there can be no matching record in the other file. Therefore, immediately before a record without match fields is processed, the MR indicator is turned off.

For the next program cycle, the ITEM record for item 101 is read to replace the category record processed. The date record from the secondary file is still in the read area. Since the secondary file record has no match fields, no comparison is made, and the date record is automatically processed. Once again, the MR indicator is turned off right before processing a record without match fields.

The remaining records would be processed in the order shown in Figure 6-24. When records with match fields are in the read area, the record with the lowest match field is selected for processing. If both match fields are the same, the record from the primary file is always selected. Of course, if one of the records has no match field, it is processed immediately after the record it follows, regardless of which file it is in. As shown in Figure 6-24, there are matching SALES file records for the ITEM file record with a match field value of 286. Since a record without match fields (the category record for SMALL APPLIANCES) follows this ITEM record in the primary file, the record without match fields is processed before the SALES records which match ITEM record 286. You should be aware that this processing order may be undesirable in your program.

## **MATCHING RECORDS: WHEN ALL RECORDS IN ONE FILE HAVE BEEN PROCESSED**

When you are using two or more input-type data files in a program, end of file is always reached in one file before all the cards in the other file have been processed. This is because the matching record function can only select one card at a time for processing. Furthermore, each file often contains a different number of records.

Usually, in multifile processing, you want the program to continue until all records from all files have been processed. RPG II logic will do this. The last record indicator (LR) is not turned on until the last record in the last file is read.

Let's go over the last few program cycles in the example last presented. At a particular point in the program, there will be two records left in the primary file (item 321 and a /\* record) and three records in the secondary file which have not been processed (two for item 321 and a /\* record).

At the beginning of a program cycle, the ITEM record for 321 and the first SALES record for item 321 would be in the read area. Since both match fields are the same, the primary file record is processed, with the MR indicator turned on before processing.

The next primary file record, an end of file (/\*) record, is then read. In a single file program, reading a /\* record tells the program there are no more data records to process. The last record (LR) indicator is then turned on causing total time operations to be performed, and then the program ends.

In multifile processing, however, reading a /\* record from one file does not necessarily mean that all records from all files have been processed. Thus, the program must determine if end of file has previously been reached in the other file(s). In this case, the SALES file still contains three unprocessed records. Therefore, reading the /\* record from the primary file merely indicates that there are no more records from that file to process. The remaining data records in the SALES file are processed, one at a time, in the order in which they are read.

When the end of file record from the secondary file is read, the program determines if end of file has been reached in the other file. Since it has, the LR indicator is then turned on. In this program, there are not total calculations or total output to be performed; thus, the program is ended.

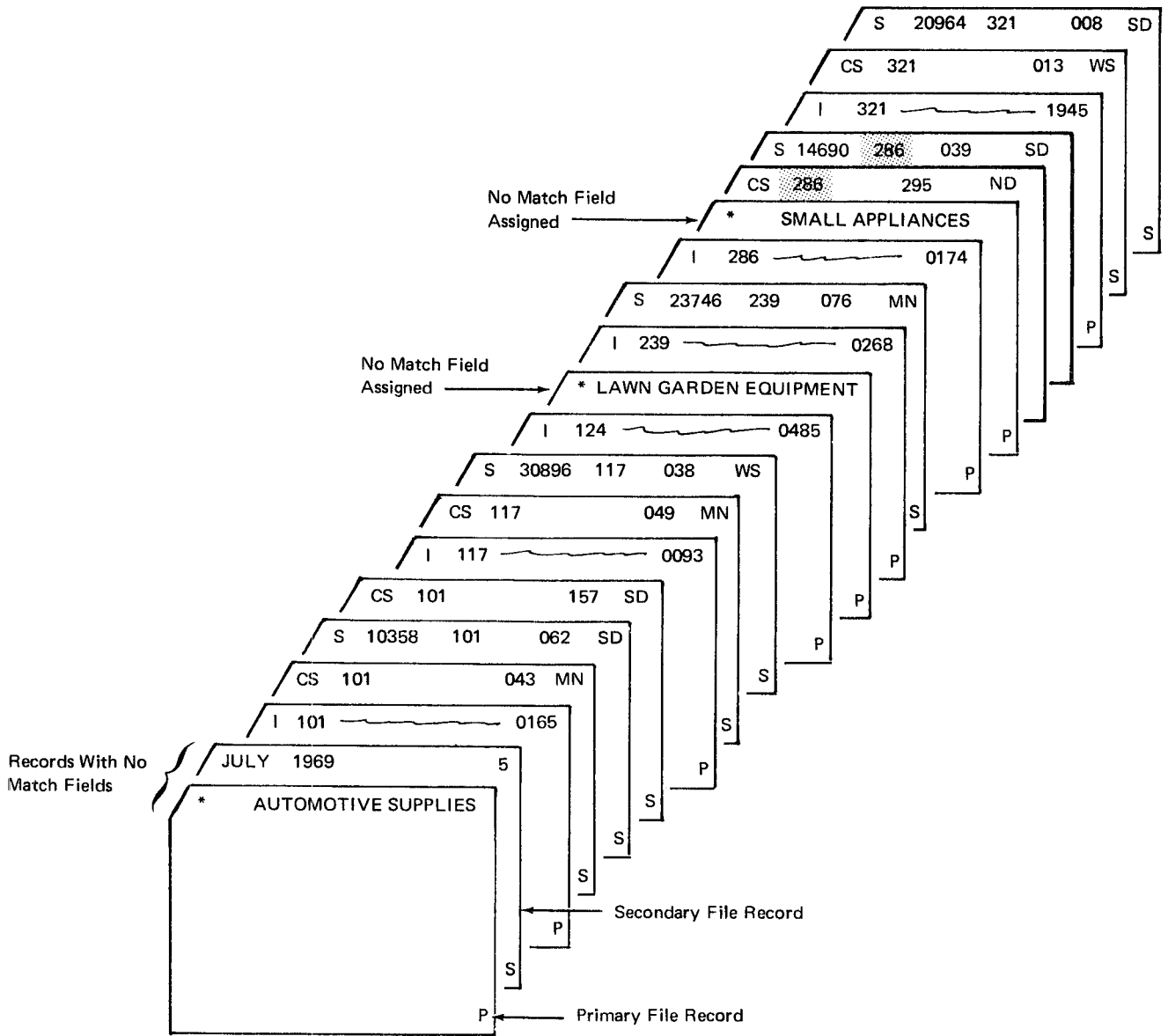

Figure 6-24. Processing Order of Records with No Match Fields





Assume the secondary SALES file contains the records shown in Figure 6-26. Following each group of sales records for a particular item is a record which gives the total sales for that item. The total records do not have match fields and thus are selected for processing as soon as they are read.

An end of file entry is assigned to the primary ITEM file. Since both files are in the same sequence, once all ITEM master records are processed, any sales records which still remain in the SALES file must be either records which match the last primary record processed, records for which there is no valid item number, or total records which are not to be matched.

When the /\* record in the primary file is read, the program checks the other file. The two SALES records for item 321 match the last primary file ITEM record processed. Thus, they are automatically processed. The next record in the SALES file, a total record without match fields, will cause the LR indicator to be turned on, and the program will end. However, if an end of file entry was not assigned to the primary ITEM file, or if the end of file entry was assigned to the secondary SALES file, all records in the SALES file will be read and processed.

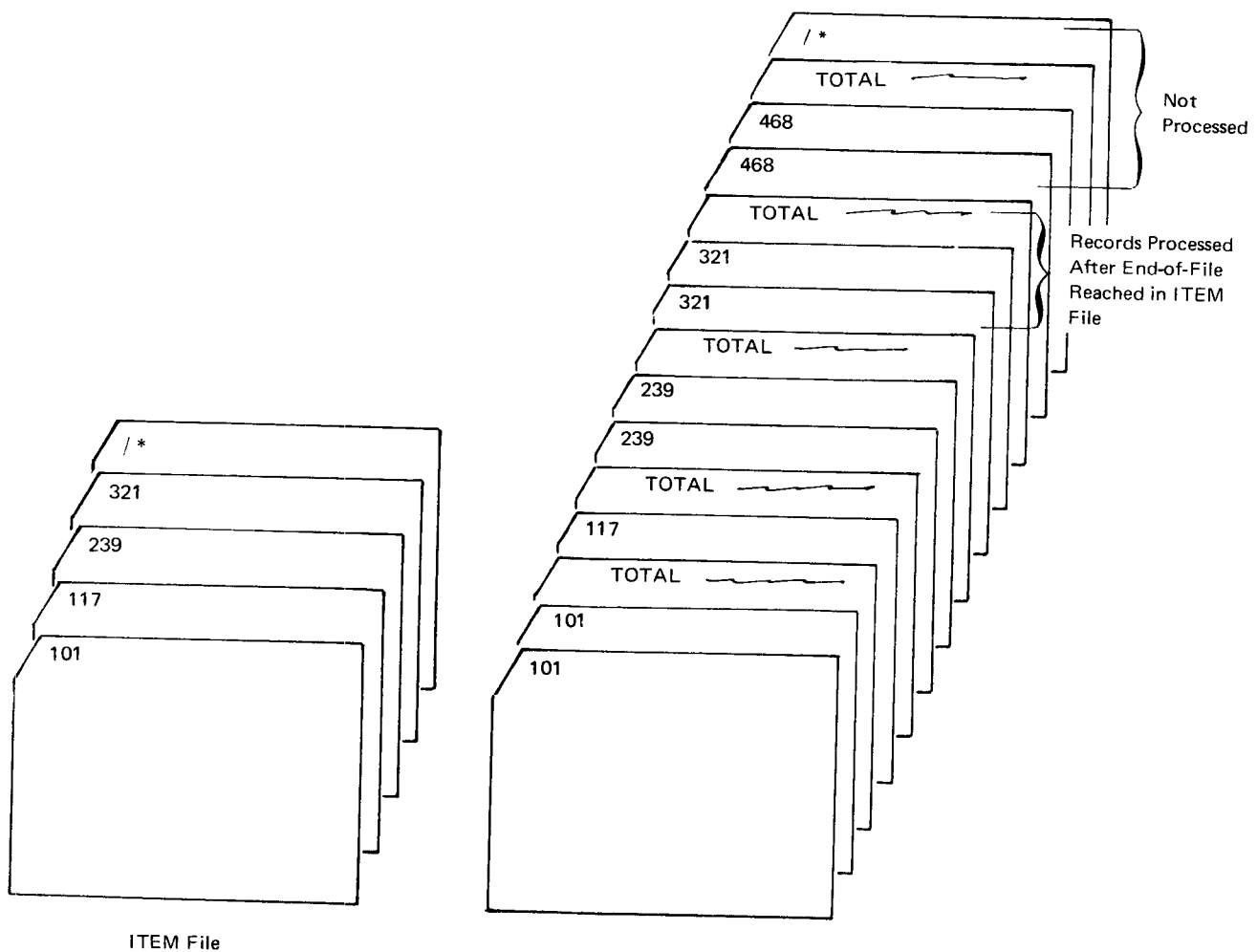

Figure 6-26. Processing a Matching Records Job After End of File

## USE OF MATCH FIELDS AND CONTROL FIELDS IN THE SAME FILE

In the previous example, the ITEM and SALES files were matched according to an item number field so that individual sales could be printed under the item description. Suppose you also wish to have the sales for each item totaled and printed, as shown in Figure 6-27.

To perform total operations on a group of records, it is necessary that control fields be assigned to distinguish one group from the next. For this program, the same item number field used for matching the records would be specified as a control field on the Input sheet (Figure 6-28). Although your files may contain both match fields and control fields, there is no relationship between the two functions performed. Even if the same fields on a record are used as both match and control fields, the only similarity is that the same data will be used in performing each function.

Match fields are checked first to determine from which file the next record is to be processed (see Figure 6-29). In effect, the matching record function is creating one file for processing by merging the data from two files. (Of course, after processing, the two files are automatically separated again into the appropriate stackers.)

In addition, comparison of the match fields determines whether the MR indicator will be turned on or off for processing of the selected record. As discussed previously, the MR indicator is to be on for processing of a primary file

ITEM	DESCRIPTION	QUANTITY	LOCATION
101	_____	43	MN
		62	SD
		157	SD
		262	TOTAL
117	_____	49	MN
		38	WS
		67	MN
		154	TOTAL
239	_____	76	MN

Figure 6-27. Printing Totals for Matching Records

I		Record Identification Codes		Field Location		Field Name		Field Indicators		
Line	Form Type	1	2	3	From	To	Field Name	Plus	Minus	Zero or Blank
01	I	AA	01	LCI	2	4	NUM	L	M	L
02	I				6	20	DESCR			
03	I				23	26	PRICE			
04	I									
05	I	BB	02	LCS	3	5	ITNUM	L	M	L
06	I				8	10	QTY			
07	I				15	16	LOCATN			

Item number fields used as both match fields and control fields.

Figure 6-28. Assigning the Same Field as a Match Field and as a Control Field

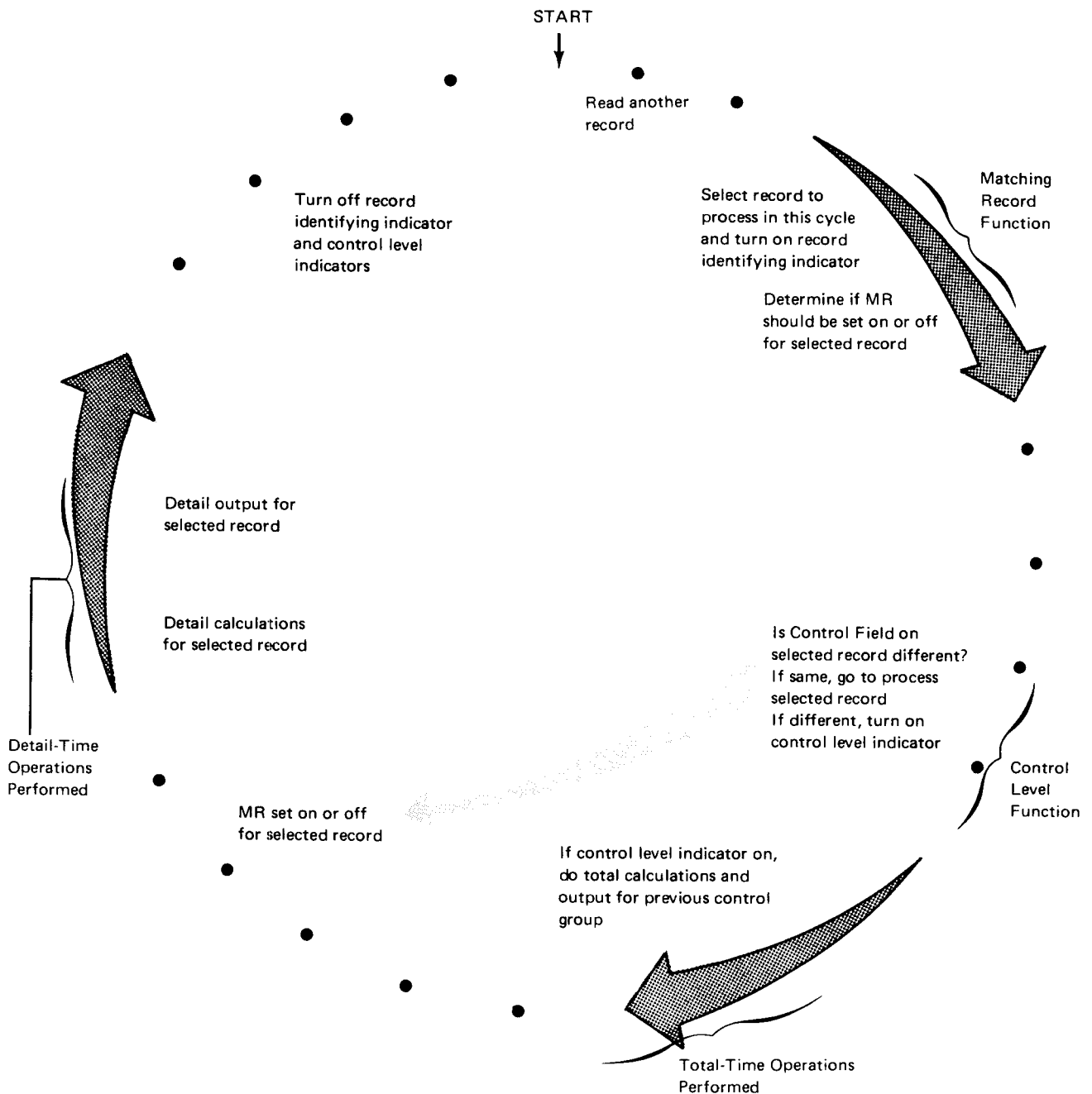

Figure 6-29. RPG II Logic of Obtaining Totals for Matching Records

record only if there is a matching record in the secondary file. Likewise, if a secondary file record is selected, MR is to be on for its processing only if a matching record from the primary file has already been processed. If an unmatched record is selected, MR is set off, of course. At this point, however, the matching record function only determines how the MR indicator is to be set; the status of MR is not actually changed yet.

Once the matching record function has selected the next record to be processed, the control level function then considers the records as one file in determining if a control break has occurred. This check is made before the selected record is processed and, thus, before the MR indicator is set for the record just selected (see Figure 6-29). The control field (item number) on the selected record is checked to see if it is different from that on the previously processed record. If it is the same, no totals are to be printed;

so the MR indicator is set, the QTY accumulated into TOTAL, and the individual record is printed. However, if the item number is different from that on the previously processed record, this means that all individual sales for the last item number have been printed. The change in the control field causes a control level indicator (L1 was assigned) to be turned on. Any total calculations and total output (operations conditioned by the control level indicator) are then performed for the previous control group. In this case, the total of all sales for the previous item are printed.

When total operations are performed, the selected record has not been processed yet. Therefore, during total time, MR is still set for the previously processed record. Once total operations are completed, MR is then set for the selected record (the first record in the next control group) so it can be processed.

Whenever a control field changes (control break), a control level indicator is automatically turned on. Furthermore, whenever a control level indicator is on, total operations will be performed. In a matching records program, however, there may be times when a control break occurs and you don't want total operations to be done. Thus, you must specify that total operations are to be performed only under certain conditions.

For this program, sales are to be added and the total printed *only* if there is an ITEM master record with matching SALES records for that item. In such a case, MR would have been set on for the last SALES record of the group. MR would still be on, then, when the control break occurs. Thus, detail operations to accumulate sales should be performed whenever MR is on and the total operations to print the TOTAL should be conditioned to be performed only with *L1 and MR* on (Figure 6-30).

**IBM** International Business Machine Corporation

**RPG CALCULATION SPECIFICATIONS**

Form GX21 9093  
 Printed in U.S.A.

---

Program \_\_\_\_\_  
 Programmer \_\_\_\_\_ Date \_\_\_\_\_

Punching Instruction \_\_\_\_\_  
 Graphic \_\_\_\_\_  
 Punch \_\_\_\_\_

Card Electro Number \_\_\_\_\_  
 Page 1 of 2 Program Identification 75 76 77 78 79 80

---

Line	Form Type	Control Level (L,O,Lg,LR,SR,AM,OR)	Indicators					Factor 1	Operation	Factor 2	Result Field		Resulting Indicators	Comments
			And	And	And	And	And				Name	Length		
0 1	C		Not	Not	Not	Not	TOTAL	ADD	QTY	TOTAL	40		ACCUM SALES	
0 2	C													

---

**IBM** International Business Machine Corporation

**RPG OUTPUT SPECIFICATIONS**

GX21 9090 U/M 050\*  
 Printed in U.S.A.

---

Program \_\_\_\_\_  
 Programmer \_\_\_\_\_ Date \_\_\_\_\_

Punching Instruction \_\_\_\_\_  
 Graphic \_\_\_\_\_  
 Punch \_\_\_\_\_

Card Electro Number \_\_\_\_\_  
 Page 1 of 2 Program Identification 75 76 77 78 79 80

---

Line	Form Type	Filename	Output Indicators				Field Name	End Position in Output Record	Constant or Edit Word
			And	And	And	And			
0 1	O	REPORT				*AUTO			
0 2	O	OR							
0 3	O								
0 4	O						27	'ITEM	
0 5	O	D			MR 0L		63	'QUANTITY	
0 6	O							'DESCRIPTION'	
0 7	O							'LOCATION'	
0 8	O	D			MR 02		6		
0 9	O								
1 0	O								
1 1	O	T 23			LL MR		3L		
1 2	O								
1 3	O								
1 4	O								

Figure 6-30. Controlling Performance of Total Operations in a Matching Records Program

Since there can be unmatched records in either file, you can have an ITEM record with no matching SALES records or invalid SALES records for which there are no matching ITEM master (see Figure 6-31). Although a control break would occur following the processing of the unmatched records, you don't want total operations to be performed. The MR indicator would be off for the unmatched records. Therefore, if you condition total time output specifications with L1 and MR on, total time would be bypassed for such cases.

### **DETERMINING WHETHER FILES SHOULD BE PRIMARY OR SECONDARY**

A basic question arises in any multiframe processing application: Which file should be designated the primary file and which is to be the secondary file? Since almost all multiframe programs involve the use of match fields to determine processing order, an understanding of matching record logic is generally essential for determining which file should be the primary file.

Since files vary among applications, we can't state absolutely that a certain file is always to be primary or secondary. However, now that you understand the basic matching records concepts, the following points may help you to make the best file designation.

If the match fields on records from two or more files are compared and found to be the same, the primary file record is always selected. Furthermore, the primary file would be given priority if none of the available records contained match fields. In general, then, if all match conditions are the same, the primary file record is the first processed.

With this idea in mind, we can say that if data from file A must be available to the program before file B can be processed, the file containing the necessary data (A) should be designated as the primary file. For example, say you have two files to process to do a customer billing application. The customers' names and addresses are recorded in one file while

the customers' transactions are in another file. A name and address is to be printed on a bill before a customer's charges and credits. The name and address record must be available for output and, thus, must be processed before the related transaction cards. In this case, the name and address file should be specified as the primary file.

Let's consider another case in which one file is to be used only as input while the other file is to be used for both input and output. In other words, the program requires one input file to be read and one combined or update file to be both read and written or punched. Usually, information from the input file would be necessary to calculate the data to be output to the combined or update file. Or, perhaps the actual input file data is to be output to the combined or update file. Either way, the combined or update file should be specified as the secondary file, so the data from the primary input file is available before the output is done.

In general, the type of data which must be available before processing another file is permanent record information, such as would be found in a master file. For instance, an employee's hourly wage from a master file is necessary before the computer can use the number of hours worked from an employee detail file to calculate net pay. Therefore, a master file is often the primary file, while a detail or transaction file is the secondary file. Of course, this is only a guideline and should not be considered the rule for all situations.

As a final point, if the first record in one of the files *must* be the first record processed in the program, you must make sure that this record would be selected. To do this, first decide which file you think should be primary and which secondary, according to the suggestions presented. Then, determine which record would be selected first in the program by the RPG II logic of matching records. If the record which would be selected is not the record which must be processed first, the primary and secondary file designation should be switched.

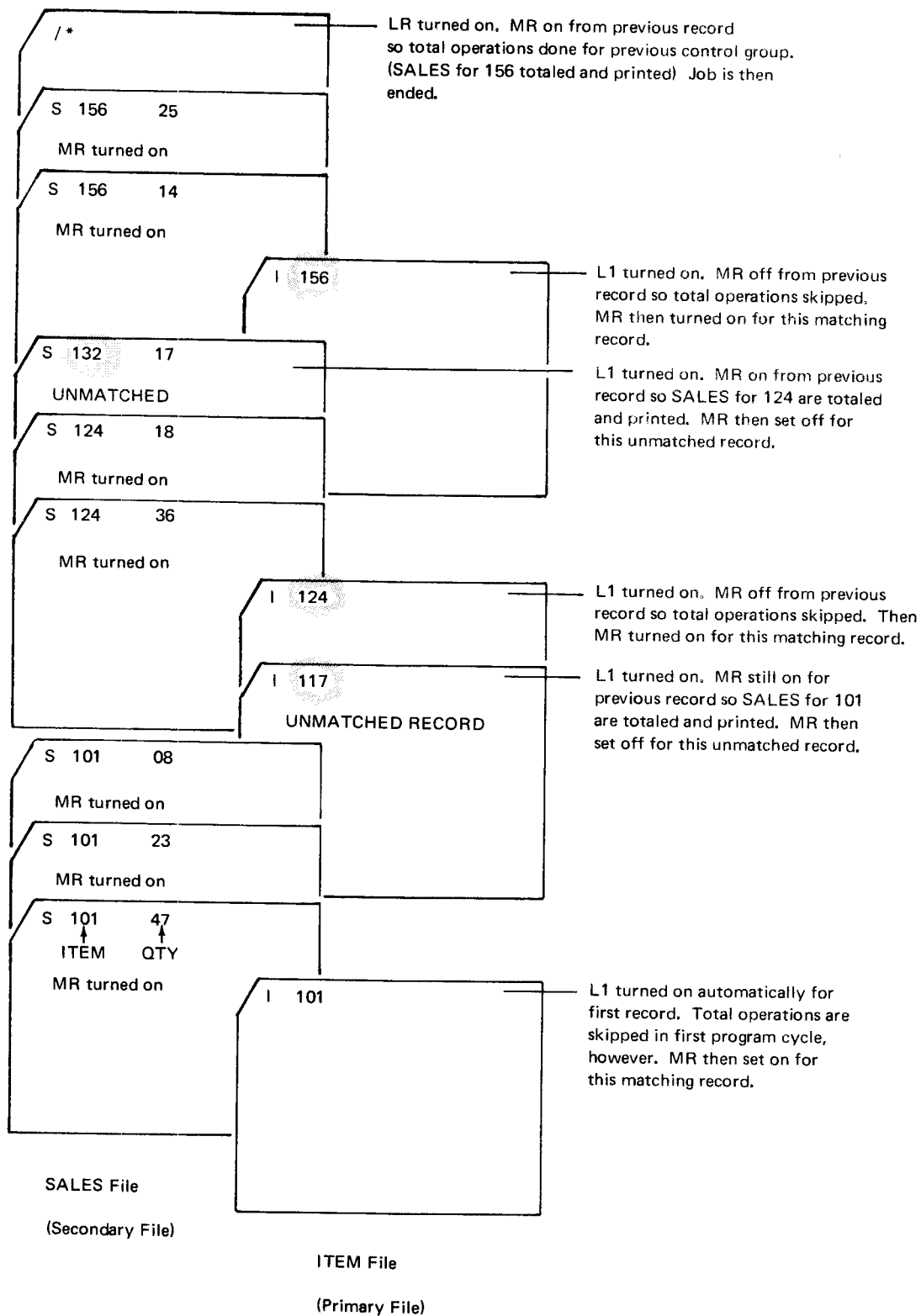

Figure 6-31. Use of MR Indicator to Determine Whether Total Operations are to be Performed





1. What are match fields used for when assigned to a single file?
2. If a record type has two match fields, which match field is assigned M1 and which is assigned M2?
3. Referring to the following Input sheet, indicate the errors in assigning match fields and the reasons the specifications are in error.

IBM International Business Machine Corporation						RPG INPUT SPECIFICATIONS													GK21-9094 U/M 050* Printed in U.S.A.												
Program						Punching Instruction			Graphic			Card Electro Number							Page <u>1</u> of <u>2</u>		Program Identification										
Programmer						Date			Punch																						
Line	Form Type	Filename	Sequence			Record Identifying Indicator						Record Identification Codes									Field Location			Field Name	Control Level (L-L9)	Matching Fields or Chaining Fields	Field Record Relation	Field Indicators			
			O	R	A	N	D	1			2			3			From	To	Decimal Positions	Plus	Minus	Zero or Blank									
								Position	Not (N)	C/Z/D	Character	Position	Not (N)	C/Z/D	Character	Position							Not (N)					C/Z/D	Character		

01	I	EMPLOYEEAA	O	R	A	N	D																																				
02	I																																										
03	I																																										
04	I																																										
05	I																																										
06	I			BB																																							
07	I																																										
08	I																																										
09	I																																										
10	I																																										
11	I																																										

4. Must match fields be assigned to all record types in a file?
5. Given the following data about a file named EMPLOYEE, code the input specifications which describe the record types in an OR relationship:  

Record type 01 identified by the character A in position 96.  
 Record type 02 identified by the character B in position 96.

<i>Field Name</i>	<i>Record Positions</i>	<i>Record Type</i>
NAME	5-15	record type 02 only
DEPT	1-4	both record types
CODE	8-9	record type 01 only
ADDRES	16-30	record type 02 only
EMPNUM (match field)	42-45	both record types
6. What are match fields used for when assigned to multiple input, update, or combined files?

Refer to the following program cycles to answer questions 7 and 8:

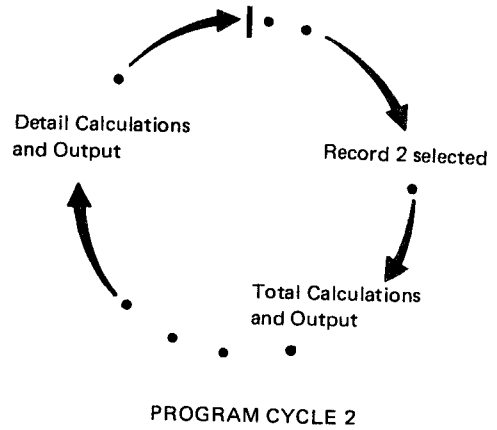
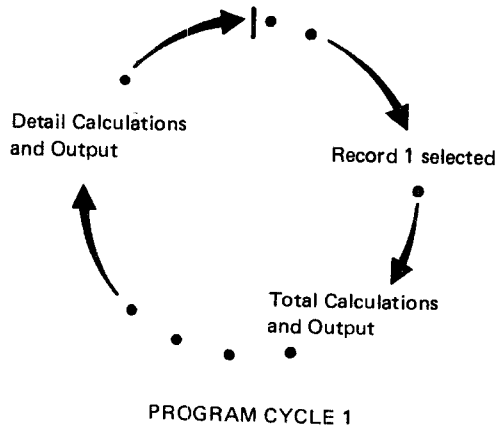

7. When is the MR indicator set on and off for the first record selected for processing?
8. When is the record identifying indicator for record 1 set on and off?
9. Define an unmatched record.
10. If a primary file record is selected for processing, what condition must be met for the MR indicator to be set on for that record?
11. If a secondary file record is selected for processing, what condition must be met for the MR indicator to be set on for that record?
12. Assume an ITEM file read from the MFCU or MFCM contains two record types. Which specification line on the following Output sheet is correct in order to stacker select unmatched records of record type 01 into stacker 3? What are the other two stacker selection specifications incorrect?

IBM		RPG OUTPUT SPECIFICATIONS			GX21-9090 U/M 050 Printed in U.S.A.					
Program		Punching Instruction		Graphic		Card Electro Number				
Programmer		Date		Punch		Page 1 2 of Program Identification 75 76 77 78 79 80				
Line	Form Type	Filename	Type (H/D/T/E)	Stacker # / Retain (E)	Space	Skip	Output Indicators	Field Name	End Position in Output Record	Constant or Edit Word
					Before	After	And And		BIAC/19/R	Commas Zero Balances to Print No Sign CR - X Remove Plus Sign Date Field Edit Zero Suppress
3	4	5	6	7	8	9	10	11	12	13
01	O	ITEM	D3				NMR			
02	O*									
03	O	ITEM	D3				ØL NMR			
04	O*									
05	O	ITEM	T3				NMR ØL			
06	O									

- An item number field is assigned as a match field for processing the two files shown. Identify the matching records (records for which MR is on), the unmatched records, and the records with no match field assigned.

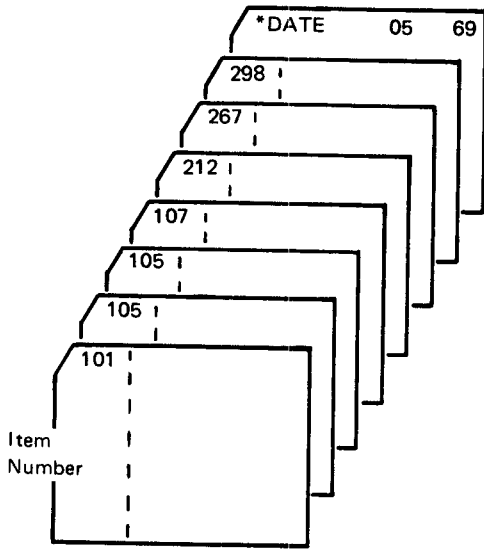

Primary File

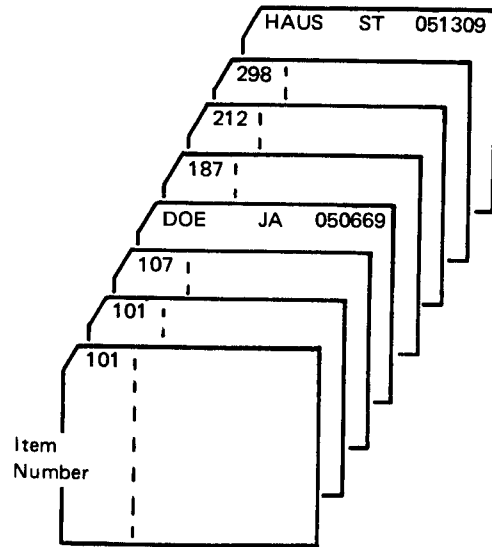

Secondary File

- Referring to the files shown in question 13, specify the order in which the records would be processed.
- What does an E in column 17 of the File Description sheet indicate? What does an A or D in column 18 indicate?
- What do the following input specifications cause to happen?

IBM		RPG INPUT SPECIFICATIONS																														GX21-9094 U/M 050* Printed in U.S.A.											
Program _____																		Punching Instruction			Graphic _____			Card Electro Number						Page 1 2 of _____		Program Identification 75 76 77 78 79 80											
Programmer _____		Date _____																Punch _____									_____		_____														
Line	Form Type	Filename	Sequence		Record Identifying Indicator	Record Identification Codes												Field Location						Field Indicators																			
			O	R		1			2			3			From	To	Field Name			Plus	Minus	Zero or Blank																					
			Number (1-16)	Option (0)		Position	Not (N)	C/Z/D	Character	Position	Not (N)	C/Z/D	Character	Position	Not (N)	C/Z/D	Character	Starkey Select	P/B/L/R	Decimal Positions	Control Level (1-16)	Matching Fields or Chaining Fields	Field Record Relation																				
0 1	I	ISLSMAN	AA	03	96	CM																																					
0 2	I	COMM	BB	05	96	CC																																					
0 3	I																																										
0 4	I																																										
0 5	I																																										

### Review Problem

The data processing department is to prepare a weekly labor distribution report showing the total number of hours worked by each employee, as well as the total number of hours worked by all employees within a department. Therefore, the report must be organized by department number and by man number within a department.

Two input files are necessary to provide data for the report:

a. PMSTER is a master payroll file containing three types of records:

- Date record – first record in file.
- Department name records.
- Employee master records.

The employee records are in ascending sequence by department number and by man number within a department. A department name record appears within the file immediately before the group of employee records for that particular department.

b. LABOR is a file of daily records containing the number of hours an employee worked. Since each employee's daily hours are recorded on a separate record, there will be more than one LABOR record for each employee.

The LABOR file is also in ascending sequence by department number and by man number within a department.

#### PMSTER File – 3 Record Types

Date Record Layout

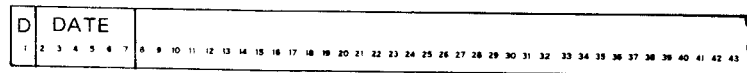

Department Name Record Layout

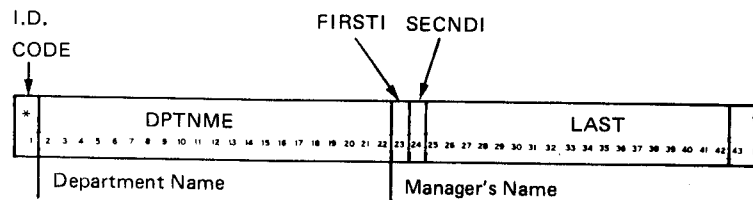

Employee Master Record Layout

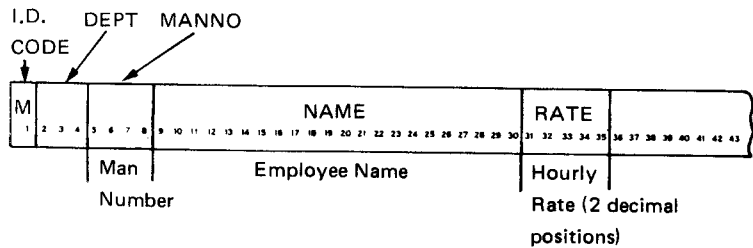

### LABOR File – 1 Record Type

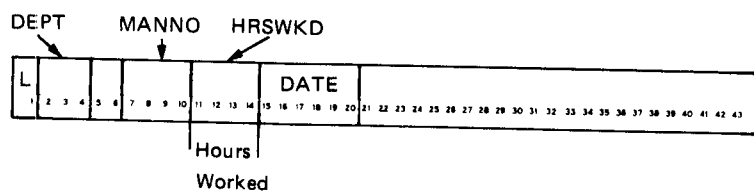

In processing the two files, there should be an employee master record related to all LABOR records. In fact, more than one LABOR record will match the same employee master record from the PMSTER file. However, it is possible that the LABOR file contains the following unmatched records:

- Records with errors in match fields.
- Records for new employees for whom employee master records have not yet been created.

If you read the LABOR file from the MFCU or MFCM, unmatched LABOR records should be stacker selected into stacker 3. Processing should end when the last record from the LABOR file has been processed.

For this program, see if you can code the following:

1. File description specifications (read the files from MFCU, MFCM, or DISK).
2. Input specifications.
3. Output-format specifications necessary to stacker select unmatched LABOR cards using the MFCU or MFCM.

# Answers To Review 6

- Match fields are used to sequence check cards within a file.
- The higher entry, M2, is assigned to the more important field.
- Reasons for specification errors:

Line 07 — Match fields of the same level must be the same length. Also, fields having the same name must be the same length, regardless if they are assigned as match fields or not.

Line 08 — Match fields of the same level must be in the same format (alphameric or numeric) *if the fields have the same name*. Also, fields with the same name must be in the same format (alphameric or numeric), regardless if they are assigned as match fields or not.

Line 10 — Every record type assigned match fields must contain the same number of match fields.

- No. Remember that record types without match fields are selected before record types with match fields.

- All fields which are common to all record types must be described first. All fields related to a particular record type are then described together as a group. Following the common fields, fields related to either record type 01 or those related to record type 02 may be described next, as follows:

IBM										RPG INPUT SPECIFICATIONS										GX21 9094 U/M 050*			
International Business Machines Corporation																				Printed in U.S.A.			
Program					Punching instructions					Graphic					Card Electro Number					Page 1 2 of		Program Identification 75 76 77 78 79 80	
Programmer					Date					Punch													
Line	Form Type	Filename	Sequence		Record Identifying Indicator	Record Identification Codes			Field Location			Field Name	Control Level (1-19)	Matching Fields or Chaining Fields	Field Record Relation	Field Indicators							
			O	R		Position	Character	Position	Character	Position	Character					From	To	Plus	Minus	Zero or Blank			
01	I	EMPLOYEEAA			01	96	CA																
02	I	OR			02	96	CB																
03	I																						
04	I																						
05	I																						
06	I																						
07	I																						
08	I																						

6. Match fields are used for two purposes:
  - a. Sequence checking the cards in each file
  - b. Matching records between the two files to determine the order of processing
7. MR set on between total time and detail time operations *during program cycle 1*.  
 MR set off between total time and detail time operations *during program cycle 2*.
8. Record identifying indicator set on immediately after record is selected during program cycle 1.  
 Record identifying indicator set off following detail time operations during program cycle 1.
9. An unmatched record is a record in either input file which does not have a matching record (same match field) in the other input file.
10. There must be a record in the secondary file with the same match field(s) as the record in the primary file.
11. The match field(s) on the secondary file record must be the same as the match field(s) on the last primary file record processed.
12. Line 03 is a correct specification for stacker selection of unmatched records.  
 Line 01 is incorrect because there is no record identifying indicator specifying the type of record to be stacker selected.  
 Line 05 is incorrect because stacker selection of a record on the basis of a matching or not matching record condition should be done at detail time, not at total time.
13. Matching records are records from both files containing item numbers 101, 107, 212, and 298.

The three unmatched records from the primary file contain item numbers 105, 106, and 267. The one unmatched record in the secondary file contains item number 187.

The \*DATE record from the primary file and the two name records from the secondary file are records with no match fields assigned.

14. The records would be processed in the following order:

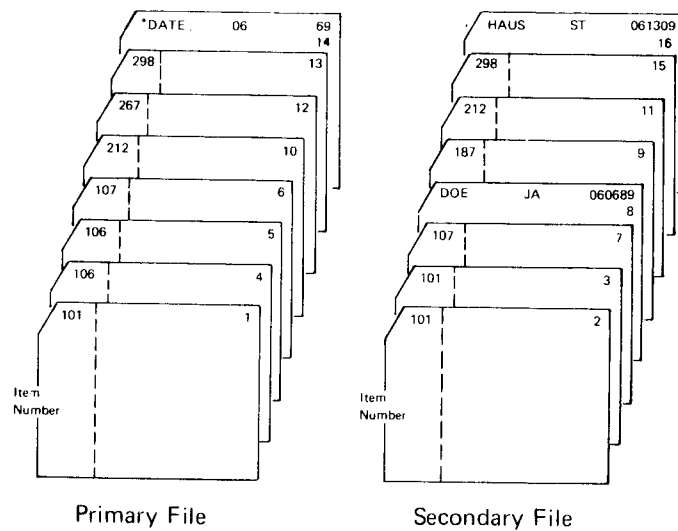



15. An E means the program should check that file for end of file. If end of file is reached (a /\* record read), usually processing of records is stopped. However, if end of file is reached in a matching records program, the matching records and records with no match fields from the other file are processed before the program is ended.

An A or D entry indicates that an input file is in ascending or descending sequence according to the match field(s) on the records.

16. First, the REGION match fields are compared to determine if there is a matching record condition and, thus, which record to process. Next, the contents of the REGION field are checked on the record selected to determine if a control break has occurred and, thus, if L1 should be set on.



### 2. Input Specifications

IBM		International Business Machine Corporation		RPG INPUT SPECIFICATIONS															GX21-9094 U/M 050*		Printed in U.S.A.		
Program:		Punching Instruction:		Graphic:		Card Electro Number:		Page 1 of 2		Program Identification:		75		76		77		78		79		80	
Line	Form Type	Filename	Sequence Number (1-N)	Record Identifying Indicator	Record Identification Codes									Field Location		Field Name	Control Level (L, U, B)	Matching Fields or Chaining Fields	Field Record Relation	Field Indicators			
					Position	Not (N)	Character	Position	Not (N)	Character	Position	Not (N)	Character	From	To					Plus	Minus	Zero or Blank	
01	I	IPMSTER	AA	01	1																		
02	I																						
03	I														2	40	DEPT	L	R	M	2		
04	I														5	80	MANN	L	M	L	M		
05	I														9	30	NAME						
06	I		BB	02	1										31	35	RATE						
07	I														2	22	DPTN	M	E				
08	I														23	23	FIRST	I					
09	I														24	24	SECND	I					
10	I														25	42	LAST						
11	I		CC	03	1																		
12	I																						
13	I*														2	70	DATE						
14	I*																						
15	I	LABOR	DD	04	1																		
16	I																						
17	I														2	40	DEPT	L	R	M	2		
18	I														7	100	MANN	L	M	L	M		
19	I														11	142	HRS	W	K	D			
20	I														15	20	DATE						

### 3. Output Specifications

IBM		International Business Machine Corporation		RPG OUTPUT SPECIFICATIONS															GX21-9090 U/M 050*		Printed in U.S.A.		
Program:		Punching Instruction:		Graphic:		Card Electro Number:		Page 1 of 2		Program Identification:		75		76		77		78		79		80	
Line	Form Type	Filename	Type (H/D/T/E)	Space	Skip	Output Indicators			Field Name	End Position in Output Record	Edit Codes B/A/C/I/G/R	P/B/L/R	Constant or Edit Word										
						Before	After	Not					Commas	Zero Balances to Print	No Sign	CR	-	X					
01	O	LABOR	D3						*AUTO														
02	O																						
03	O																						
04	O																						

## Chapter 7. Programmed Control of Input and Output

### CHAPTER 7 DESCRIBES:

- How to alter the order of processing input files using FORCE.
- How to read one or more records per cycle from a demand file.
- How to do repetitive or exception output during calculations.

### BEFORE READING THIS CHAPTER YOU SHOULD BE ABLE TO DESCRIBE:

- Multifile processing.
- Look-ahead.
- End-of-file condition.
- \*PLACE.
- RPG II program logic (Chapter 1).

### AFTER READING THIS CHAPTER YOU SHOULD BE ABLE TO DESCRIBE:

- RPG II FORCE operation code.
- Using FORCE with the look-ahead feature.
- Using the RPG II READ operation code to process demand files.
- RPG II EXCPT operation code.

*Note:* You can use the review questions contained in *Review 7* at the end of this chapter to test your comprehension of each topic in the chapter. Questions are grouped according to the topic to which they apply. Answers follow the review questions.

## INTRODUCTION

Normally, records are read, identified, selected for processing, and output according to the fixed logic of the RPG II object program. Sometimes, however, you need to have direct control over the input and output of your program. RPG II provides several operation codes which give you this control. By using the FORCE operation code in your own calculation routine, you can override normal RPG II multi-file logic for selecting input records for processing. You can also do certain kinds of input and output during calculation time by using the READ and EXCPT operation codes.

*Note:* The CHAIN operation code also allows programmed control of input and output operations. The CHAIN operation is explained in *IBM System/3 RPG II Disk File Processing Programmer's Guide*, GC21-7566.

## ALTERING THE ORDER OF PROCESSING FILES (FORCE OPERATION)

RPG II uses two methods to determine the order in which records are processed in a multifile program.

- If match fields are not specified for either file, all records in the primary file are processed, followed by those in the secondary files in the order defined on the File Description sheets.
- When match fields are assigned, the RPG II logic of matching records determines from which file the next record is to be processed.

The order of processing determined by RPG II logic is appropriate for most of your multifile programs. However, for certain programs, it may be necessary to have some of the records in the two files processed in an order other than that in which RPG II logic would select the records.

A record can be processed out of order only if you indicate to the program that the file containing that record is to be forced. To do this, you must code additional specifications to override normal RPG II multifile logic.

Regardless of how your files are organized, the following situations require that you alter the order of processing:

1. Match fields cannot be assigned to the files and you wish to:
  - a. Alternate processing between two files.
  - b. Process a primary file record followed by a particular number of secondary file records.
  - c. Process a secondary file record only when it matches a primary file record.
2. Match fields are assigned to both input files. You wish to process one primary file record, followed by matching secondary file records, then the rest of the matching primary records.

To alter the order of processing, you must first determine which file is to be processed—when and under which conditions. Once you know the order, the next step is to determine, for a particular programming cycle, whether the RPG II logic will select the appropriate record or if you must force the processing of that record.

The first record to be processed in any program can only be selected by RPG II logic in the usual way. Thereafter, to alter the order of processing, you tell the program to force a record from a file which would not ordinarily be processed next. Once the forced record is processed, and providing another record is not forced, the RPG II logic selects the next record in the usual way. This is the record which would have ordinarily been processed if the other file had not been forced.

### Specifying the Next File to Process

To process a record out of its normal sequence, you specify on the Calculation sheet the FORCE operation code and the name of the file which is to be forced in the *next* program cycle (Figure 7-1).

Assuming a record type 01 from the primary file is being processed, the calculation on line 01 is performed. The next detail-time calculation specification for record type 01 indicates that the secondary file (SECOND) is to be forced. The FORCE does not occur immediately, however. This specification only tells the program to remember that a record from the file SECOND is to be processed next. Any additional calculations and/or output for the record being processed are performed first to complete the present program cycle.

At the beginning of a normal program cycle, RPG II logic looks at the two records available in order to select the one to process during that cycle. However, if the record from the file which would not normally be selected is to be processed, this must be indicated to the program before the beginning of the cycle. If a file is to be forced, there is no need for RPG II logic to compare the records and make a selection. This is the reason that, if a file is to be forced, the FORCE must be indicated during the program cycle immediately before the cycle in which the FORCE is to occur.

Depending on your program, you may not have to force a record in every program cycle. For such situations, you must indicate when the FORCE is to be done by specifying conditioning indicators in columns 9-17 of the Calculation sheet (Figure 7-1). Whether the FORCE is to be performed in the next cycle or not may depend on any of several conditions:

- The type of file or record type being processed at the time.
- The number of records which have been processed.
- The result of a calculation performed.
- The contents of a field on the record being processed.
- The contents of a field on a record which has not been processed yet.

With these points in mind, let's discuss a job in which you can determine if the order of processing must be altered on the basis of the type of record being processed.

**RPG CALCULATION SPECIFICATIONS**

Form GX21-9093  
Printed in U.S.A.

IBM International Business Machine Corporation				Punching Instruction		Graphic Punch		Card Electro Number		Page <input type="text"/> 1 <input type="text"/> 2 of <input type="text"/>	Program Identification <input type="text"/> 75 <input type="text"/> 76 <input type="text"/> 77 <input type="text"/> 78 <input type="text"/> 79 <input type="text"/> 80				
Program		Programmer		Date		Punching Instruction		Graphic Punch		Card Electro Number		Page <input type="text"/> 1 <input type="text"/> 2 of <input type="text"/>		Program Identification <input type="text"/> 75 <input type="text"/> 76 <input type="text"/> 77 <input type="text"/> 78 <input type="text"/> 79 <input type="text"/> 80	

C Line	Form Type	Control Level (LD, LG, LR, SR, AN, OR)	Indicators			Factor 1	Operation	Factor 2	Result Field		Resulting Indicators	Comments
			And	And	And				Name	Length		
01	C		01			TOTAL	ADD	SALE	TOTAL			
02	C		02			QTY	MULT	PRICE	AMOUNT			
03	C		01				FORCE	SECOND				
04	C											
05	C											
06	C											
07	C											
08	C											
09	C											
10	C											

Condition under which force is to be performed.

Additional calculations.

Figure 7-1. Specifying the File to be Processed in the Next Program Cycle

### Alternating Processing Between Two Files

The two files in Figure 7-2 each contain one record for every salesman in a company. The MASTER records are arranged in alphabetical order by salesman name; the MONTH file is arranged in ascending sequence by salesman number. Although there is no common match field, the records in the two files are, nevertheless, in a one-to-one correspondence. Salesmen numbers have been assigned such that they correspond to the order of the salesmen names. Thus, the first record in each file is for Baker (salesman #10); the second record in each file is for Costello (salesman #20), and so on.

The two files are to be processed to determine the amount of commission earned by each salesman. To do this, a salesman's commission rate from his MASTER record must be multiplied by the amount of his sales contained on his MONTH record (Figure 7-2). The calculated commission is then recorded in the salesman's MONTH record.

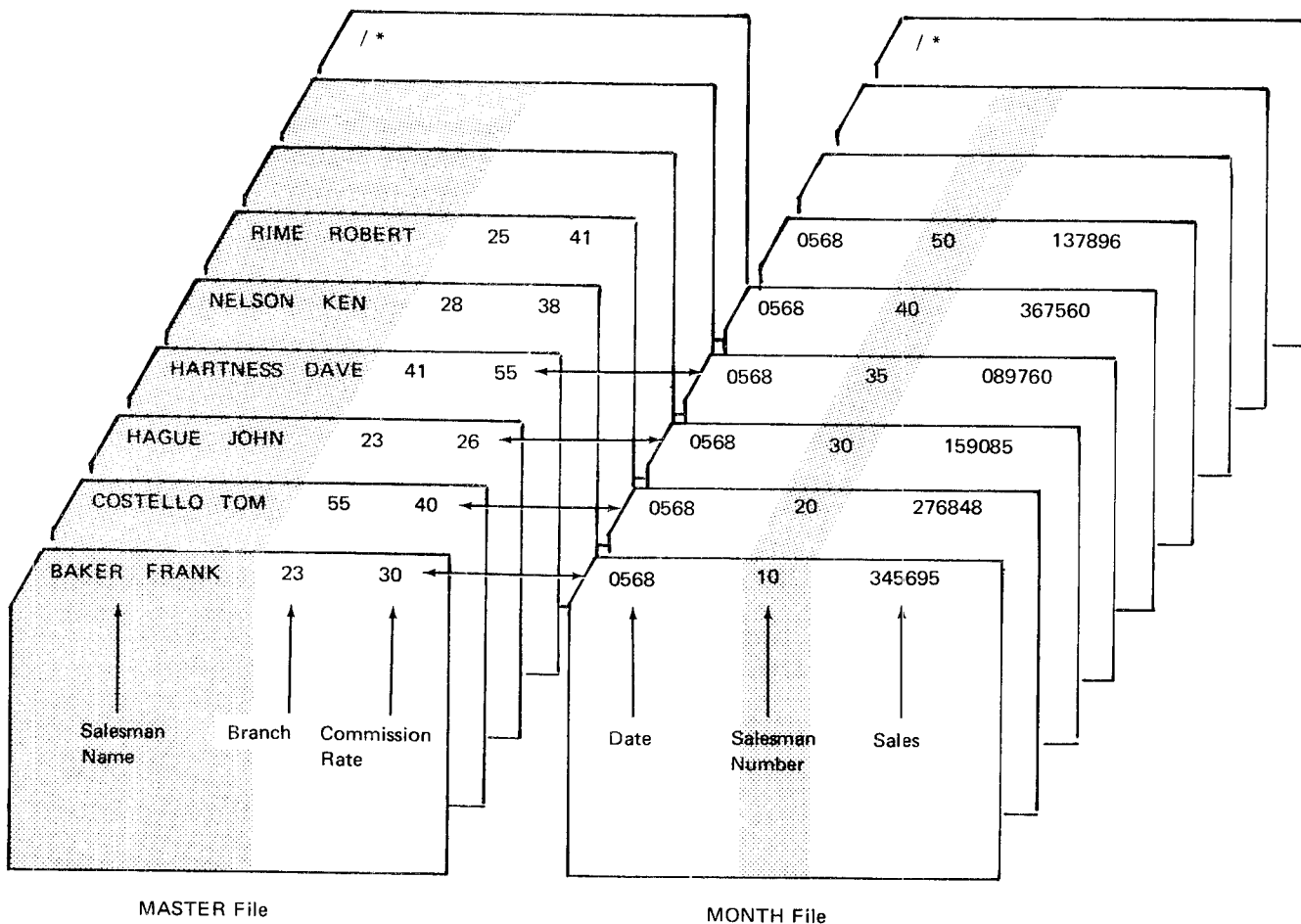

Figure 7-2. Files to be Alternately Processed





Since no match fields are assigned, RPG II logic would normally process all records in the primary MASTER file before any of the secondary MONTH records. To alternate the files, you must tell the program to force a secondary file record every time a primary file record is being processed. When a MASTER record is being processed, record identifying indicator 01 is on. Thus, you should condition the FORCE operation to be performed only if 01 is on (Calculation sheet in Figure 7-4).

At the beginning of the program, RPG II logic automatically selects the first record, which is a primary file record. Since 01 is on, the FORCE operation is performed; that is, the program notes that a MONTH record is to be forced at the beginning of the next cycle.

During processing of the forced record (02 on), the commission is calculated and recorded in the MONTH record (Figure 7-4). Only the specifications for record type 02 are done. Therefore, the FORCE operation is not performed.

Since no FORCE was indicated in this cycle (02 on), RPG II logic again takes over to select a record, at the beginning of the next cycle. Thus, the second primary file MASTER record is processed (01 on). Processing of the files continues with the next MONTH record being forced and then another MASTER record being selected by RPG II logic until all records have been processed.

**IBM** International Business Machine Corporation

Form GX21-9093  
Printed in U.S.A.

### RPG CALCULATION SPECIFICATIONS

Page 1 2 of 75 76 77 78 79 80

Line	Form Type	Control Level (LO, LR, LR, SR, AN, OR)	Indicators						Factor 1	Operation	Factor 2	Result Field		Resulting Indicators	Comments
			Not	And	And	Not	Not	Not				Name	Length		
01	C		02					RATE	MULT SALES		COMMIS	b2H			
02	C		01						FORCE	MONTH					
03	C														
04	C														

**IBM** International Business Machine Corporation

Form GX21-9090 U/M 0507  
Printed in U.S.A.

### RPG OUTPUT SPECIFICATIONS

Page 1 2 of 75 76 77 78 79 80

Line	Form Type	Filename	Type (H/D/T/E)	Space	Skip	Output Indicators						Field Name	Edit Codes	Print Position in Output Record	Field	Constant or Edit Word	
						Before	After	Before	After	Not	And						And
01	O	MONTH	D									02			COMMIS	23	
02	O																
03	O																

Figure 7-4. Conditioning Operations on Basis of Record Type

### Forcing a Number of Records from a File

In the last example, the FORCE operation was performed only if a particular record identifying indicator was on. Now let's consider a case in which you condition the FORCE operation on the basis of whether a resulting indicator is on or off.

Suppose you have a number of customers who periodically order items to be delivered from a central warehouse. One record is kept for each unit in stock in the warehouse, and another record for each customer's order of a particular unit.

Orders are processed according to the type of unit ordered. Therefore, for a particular run, the primary file (ORDER) contains all order records for only one type of unit, and the secondary file (STOCK) contains all in-stock records for that type of unit.

For this run, the ORDER file (Figure 7-5, insert A) contains the week's order records for television sets, unit number 4607. The records show which customer placed the order, and the quantity of television sets wanted. The STOCK file consists of a separate record for each television set (unit 4607) in stock (Figure 7-5, insert B). Each record provides the unit number, list price, and serial number of the item.

There are two purposes for processing the files. First, you want an indication of which orders can be filled and which orders cannot be filled. Secondly, the STOCK file is to be kept up-to-date so it only contains as many records as there are television sets available.

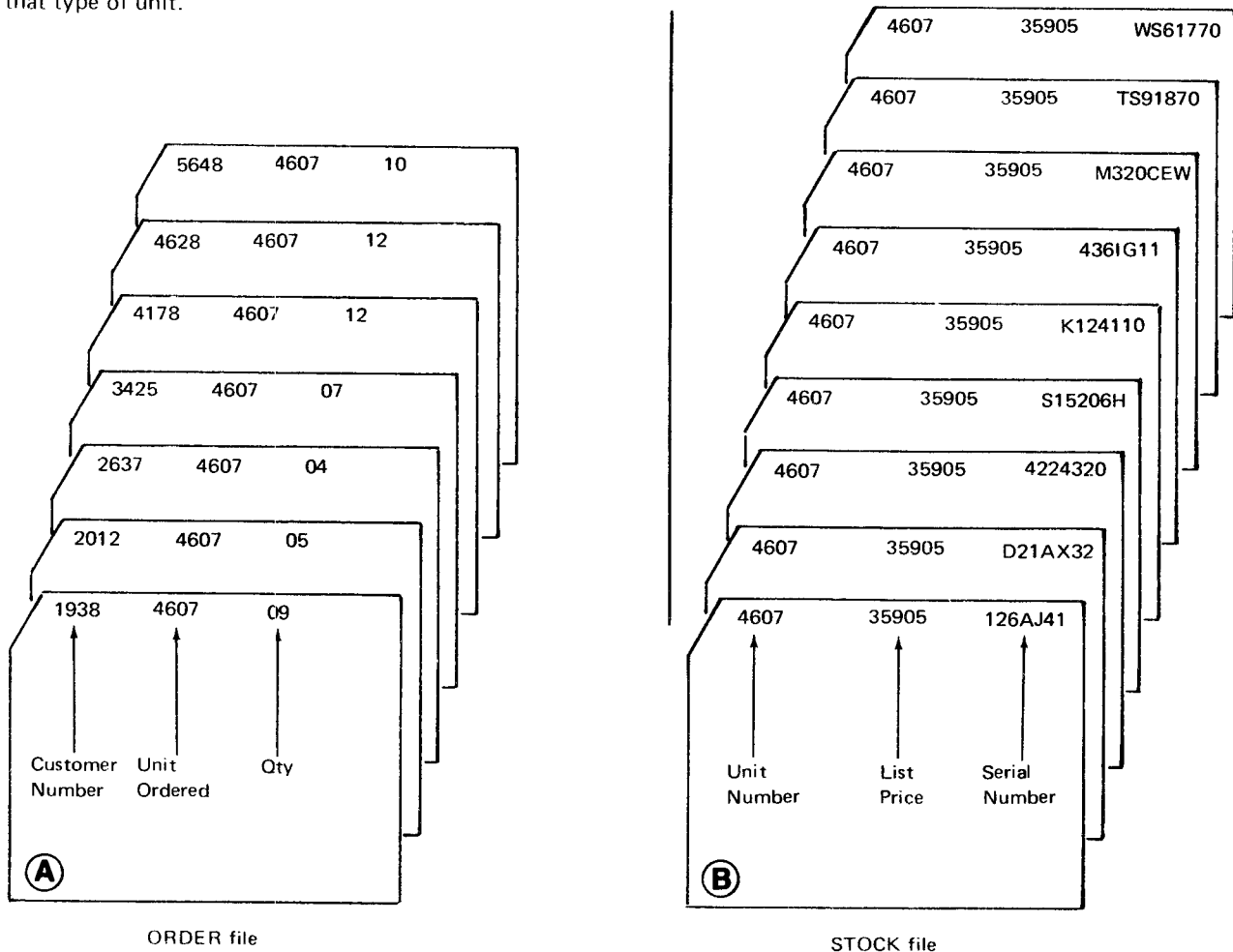

*Note:* System/3 will allocate two decimal places in the list price, although a decimal does not appear in the field. The list price in the stock file is logically represented as \$359.05.

Figure 7-5. Files for Processing Customer Orders

The program should produce a printed report showing which orders can be filled, and the amount each customer owes (Figure 7-6). Thus, you must determine the amount due for each item and the total amount for each order. A record from each file must be available before you can calculate the information.

Files for this program must be processed in a specific order. The quantity ordered (QTY) from an ORDER record must be available first. This quantity is used to determine how many STOCK records are to be processed. When enough STOCK records for an order have been processed, the next ORDER record is selected to repeat the process.

Looking at the two files, you can see that every record has a common field containing the unit number. It does no good to assign a match field to control processing order, because the unit number is always the same for every record. All records in the primary file would be processed before any secondary file records.

Remember, there is no way you can control selection of the first record to be processed in a program. RPG II logic always selects a primary file record first when match fields are not specified. Since an ORDER record must be available first for this program, the ORDER file should be designated as the primary file.

### Controlling the Number of Times FORCE is Performed

After RPG II selects and processes an ORDER record, you must FORCE the processing of a number of STOCK records. The quantity ordered (QTY) from the ORDER record is used to control the number of times you force secondary file records. The quantity is stored in a field, called COUNT, to keep track of how many records are left to be forced for an order. Each time a STOCK record is forced, the number in COUNT is reduced by one. When COUNT reaches zero, enough STOCK records have been processed for that particular order. Then RPG II logic can again take over to process the next ORDER record (Figure 7-7).

The calculation specifications shown for this program (Figure 7-8) only determine if a record is to be forced in the next cycle.

Assume the first ORDER record (record type 01) has been selected, making the quantity ordered (QTY) available. The first calculation specification (line 01) for this record type stores the quantity in the COUNT field. Then the program determines if any STOCK records are to be processed for this order (line 05). If COUNT is greater than zero, indicator 27 turns on. With 27 on, line 06 is performed, indicating a STOCK record must be forced in the next program cycle.

CUSTOMER	ITEM	QTY	SERIALNO	COST	TOTAL
1938	4607	09			
			126AJ41	359.05	359.05
			DZ1AX32	359.05	718.10
			4324320	359.05	1077.15
			S15206H	359.05	1436.20
			K124110	359.05	1795.25
			436IG11	359.05	2154.30
			M320CEW	359.05	2513.35
			TS91870	359.05	2872.40
2012	4607	05	WS61770	359.05	3231.45
			—	359.05	359.05
			—	359.05	718.10
			—	359.05	1077.15
			—	359.05	1436.20
2637	4607	04	—	359.05	1795.25
			—	398.95	398.95
			—	398.95	797.90
			—	398.95	1196.85
3425	4607	07	—	398.95	1595.80
			—	367.03	367.03
			—	367.03	734.06
			—	367.03	1101.09
			—	367.03	1468.12

Figure 7-6. Printed Report Showing Customer Orders Processed

At the beginning of the second cycle then, the first STOCK record (record type 02) is selected (by being forced). Line 03 is performed to reduce the COUNT by one for this record being processed. The COUNT is then compared to zero again (line 05) to determine if any more STOCK records are to be processed for this order. If COUNT is still greater than zero (27 set on again), line 06 is performed again, indicating another STOCK record is to be forced at the beginning of the next cycle.

During processing of the second STOCK record, COUNT is again reduced by one (line 03). Assuming COUNT is now at zero, the COMPARE operation on line 05 sets indicator 27 off. With 27 off, the FORCE operation on line 06 is not performed during this cycle. At the beginning of the next program cycle then, RPG II selects the next ORDER record from the primary file in the usual way.

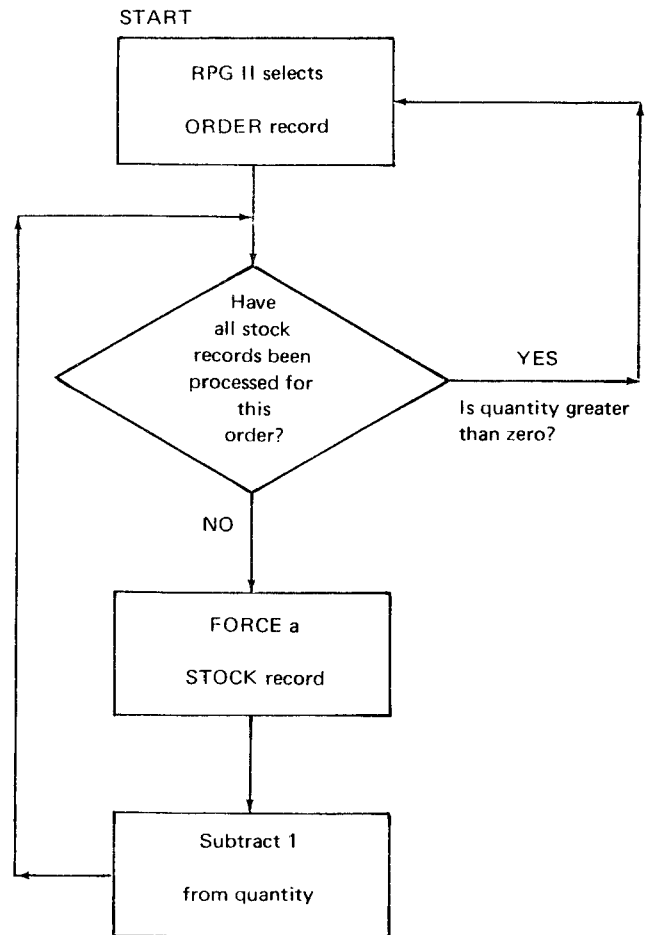

Figure 7-7. Determining When Stock Records Must be Forced to Fill an Order

RPG CALCULATION SPECIFICATIONS																																																																															
IBM		Control Level (L0-L9)		Punching Instruction		Graphic Punch		Card Electro Number		Page 1 2 of		Program Identification 75 76 77 78 79 80																																																																			
Line	Form Type	Control Level	Not	And	And	Factor 1	Operation	Factor 2	Name	Length	Decimal Positions	High	Low	Equal	Comments																																																																
01	C		01				MOVE	QTY	COUNT	20																																																																					
02	C*																																																																														
03	C		02			COUNT	SUB	01	COUNT																																																																						
04	C*																																																																														
05	C					COUNT	COMP	00						27																																																																	
06	C		27				FORCE	STOCK																																																																							

Figure 7-8. Controlling the Number of Times a File is Forced

At this point, add the specifications for calculating the amount due and for printing the report (Figure 7-9). An ORDER record is selected first, making the QTY available. Calculation lines 01, 02, and 06 in Figure 7-9 are performed for this record (record type 01). First, a TOTAL field, to be printed for each group of customers, is set to zero (line 01). Next, the quantity ordered is moved into the COUNT

field (line 02). If COUNT is greater than zero, indicator 27 is turned on (line 06), and line 07 is performed; the program is instructed to force a STOCK record at the beginning of the next cycle. Before forcing, however, the output specifications (Figure 7-9, lines 08-11) are performed to print data from the ORDER record.

IBM International Business Machine Corporation			RPG CALCULATION SPECIFICATIONS																				Form GX21-9093 Printed in U.S.A.	
Program			Punching Instruction					Graphic					Card Electro Number					Page 1 2 of		Program Identification 75 76 77 78 79 80				
Programmer			Date					Punch																
Line	Form Type	Control Level (L, O, L, R, SR, AN, OR)	Indicators			Factor 1	Operation	Factor 2	Result Field		Resulting Indicators			Comments										
			And	And	And				Name	Length	Arithmetic	Plus	Minus		Zero									
01	C		01			TOTAL	SUB	TOTAL	TOTAL	72														
02	C		01			TOTAL	MOVE	QTY	COUNT	20														
03	C		02			TOTAL	ADD	COST	TOTAL															
04	C		02			COUNT	SUB	01	COUNT															
05	C*																							
06	C					COUNT	COMP	00			27													
07	C		27				FORCE	STOCK																
08	C																							

IBM International Business Machine Corporation			RPG OUTPUT SPECIFICATIONS																				Form GX21-9090 UJM 050* Printed in U.S.A.	
Program			Punching Instruction					Graphic					Card Electro Number					Page 1 2 of		Program Identification 75 76 77 78 79 80				
Programmer			Date					Punch																
Line	Form Type	Filename	Type (H, D, T, E)	Space	Skip	Output Indicators			Field Name	End Position in Output Record	Constant or Edit Word													
						And	And	And			Commas	Zero Balances to Print	No Sign	CR	-	X	Remove Plus Sign							
01	O	REPORT	H	306					LP	29														
02	O	OR	H						QF	37														
03	O									61	'CUSTOMER	ITEM	QTY											
04	O										'SERIALNO'													
05	O										'COST	TOTAL												
06	O*																							
07	O*																							
08	O		D					01		12														
09	O									20														
10	O									25														
11	O																							
12	O		D					02																
13	O									36														
14	O									50														
15	O									61														

Figure 7-9. Specifications to Process Customer Orders



After processing the last STOCK card for that order, no more STOCK cards are to be forced, so RPG II logic tries to select the next primary file ORDER record. In doing so, the /\* card from the ORDER file is read. Since the program is to continue until both files are processed, RPG II logic automatically processes the remaining records in the other file (STOCK). As each remaining STOCK record is processed, the calculations and output for that record type are performed and the card goes into stacker 4, as if the record were being used to fill an order.

Although processing is to continue until both files reach end of file, you must have a way of determining when the first file runs out and which file it is. This is necessary so that normal calculations and output for the remaining cards can be bypassed and stacker selection specifications per-

formed instead. Reading a /\* card from a file will not necessarily indicate that end of file has been reached in all files. The LR indicator is turned on only when the /\* card of the last file has been read. Therefore, a trailer card should be placed at the end of each file (Figure 7-11), before the /\* card, to indicate when all cards of the file have been processed. When a trailer card is read, the record identifying indicator associated with that card turns on to indicate which file has been completely processed. For this program, the trailer card in the ORDER file will turn on indicator 03, while the trailer card in the STOCK file will turn on indicator 04.

Let's look at the completed calculation and output specifications for this program (Figure 7-12) to understand how the trailer cards are used to control processing.

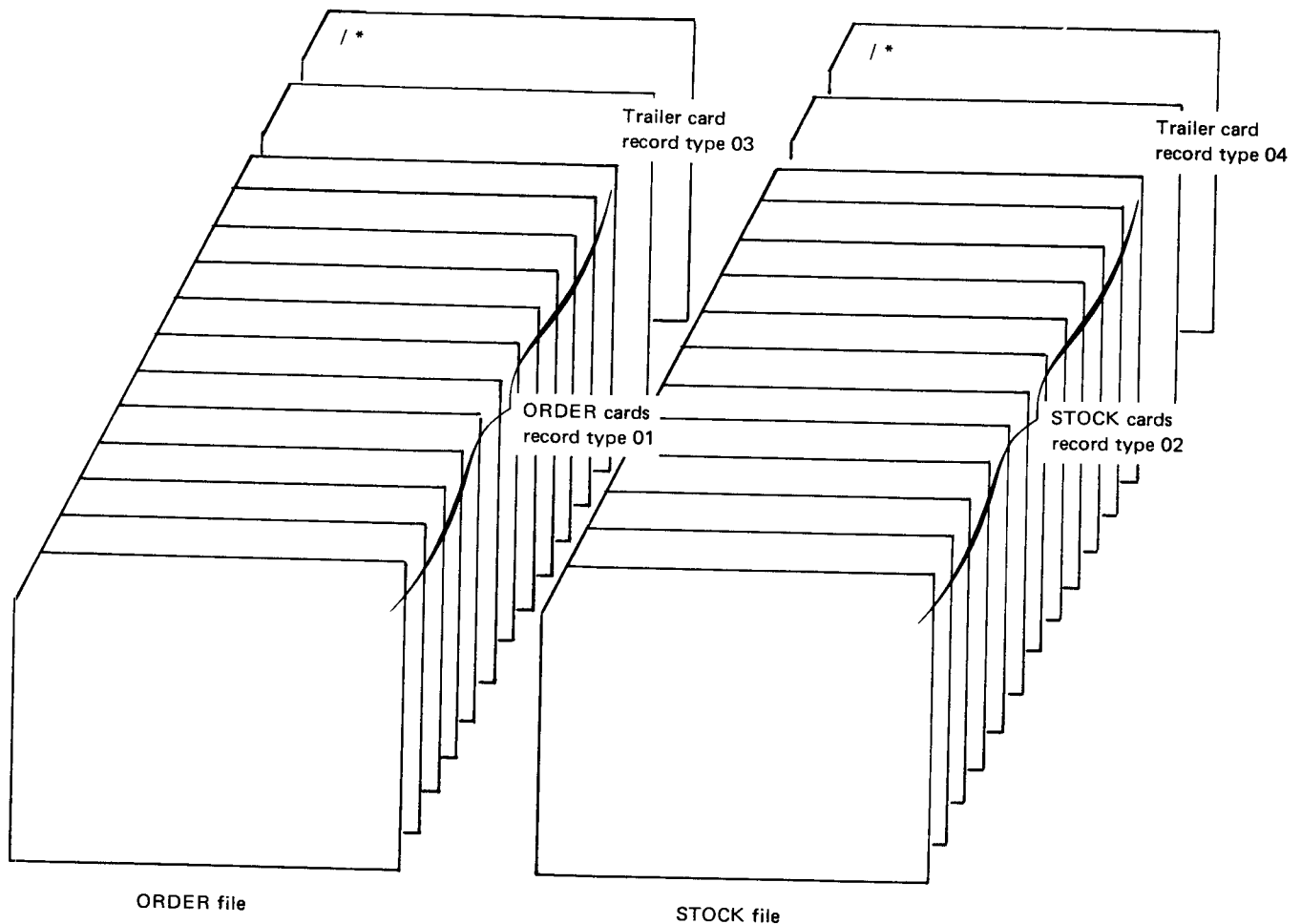

Figure 7-11. Use of Trailer Cards to Control End-of-File Processing





At this point, the first of the remaining ORDER cards is read. Since indicator 34 is still on, all calculations for the ORDER card are bypassed (see calculation line 06). The normal output for the ORDER record is to be performed only if indicator 34 is off. Thus, the printer output for record type 01 (output lines 06-09) is skipped and the record is selected into stacker 2 instead (output line 20).

As you have seen, the trailer cards from each file are used to set on particular indicators. When the ORDER file trailer card (record type 03) is read, indicator 33 is set on. Likewise, indicator 34 is set on when the STOCK file trailer card (record type 04) is read. The indicator which is set on (33 or 34) is used to prevent certain operations from being performed and to cause remaining records in the other file to be stacker selected.

Of course, reading a trailer card does not mean there are always cards remaining in the other file. For instance, assume all ORDER cards have been processed, but not all STOCK cards. When the ORDER file trailer card is read, it

signals that the remaining STOCK cards should be stacker selected. As the STOCK cards are stacker selected, one-by-one, eventually you reach the end of STOCK by reading the trailer card from the STOCK file. At this point, both files have reached end of file, the LR indicator is automatically set on, and the program is ended.

When the ORDER file trailer card is read (03 set on), then you want to know if the STOCK file has been completely processed. If it has, the STOCK file trailer card (record type 04) has already been read, and the indicator set on by 04 (indicator 34) would still be on. With 34 on, there's no point in having record type 03 set on indicator 33. Likewise, if indicator 33 is on (ORDER at end of file) when the STOCK file trailer card (record type 04) is read, there's no point in having record type 04 set on indicator 34. For this reason, the calculations on lines 01 and 04 of Figure 7-12 have been conditioned by N34 and N33, respectively.

As you know, the setting of an assigned indicator can determine whether a FORCE is to be performed or not in the

IBM		RPG OUTPUT SPECIFICATIONS			GX21-9090 U/M 050*										
International Business Machine Corporation				Printed in U.S.A.											
Program	Punching Instruction	Graphic	Card Electro Number	Page 1 2 of	Program Identification 75 76 77 78 79 80										
Programmer	Date	Punch													
Line	Form Type	Filename	Type (H/D/T/E)	Stacker # / Search F	Space	Skip	Output Indicators	Field Name	End Position in Output Record	Commas	Zero Balances to Print	No Sign	CR	-	X
					Before	After	And			Yes	Yes	1	A	J	Remove Plus Sign
					After		And			Yes	No	2	B	K	Date
							And			No	Yes	3	C	L	Field Edit
										No	No	4	D	M	Zero Suppress
										Constant or Edit Word					
01	O	REPORT	H	306				'AUTO							
02	O	OR													
03	O														
04	O								29						'CUSTOMER ITEM QTY'
05	O								37						'SERIALNO'
06	O								61						'COST TOTAL'
07	O		D												
08	O														
09	O														
10	O														
11	O		D												
12	O														
13	O														
14	O		D												
15	O														
16	O														
17	O														
18	O*														
19	O	STOCK	D3												
20	O	ORDER	D2												

Figure 7-12 (Part 2 of 2). Controlling Operations at End-of-File

following program cycle. Either a record type, data on a record, or the result of calculations performed during processing of a record can set the particular conditioning indicator on or off.

In the examples presented thus far, something about a record which was currently being processed determined whether the conditioning indicator was set on and whether an unprocessed record was forced. In the last example, the QTY field on the ORDER card determined how many STOCK records were to be forced.

### Look-Ahead to Determine Whether a File is to be Forced

For some programs, you cannot determine whether a record is to be forced in the next cycle until you know something about the records which have not been processed yet. Thus, you must look ahead in one or both files at the next record which is not yet available for processing. In looking ahead, you may be checking to determine what record type is next, to see what data is on the next record, or to determine if the next record has the same match field as the record being processed. What you find in looking ahead can determine which file is to be processed next and, also, whether the file must be forced or not.

Before considering the use of FORCE with look-ahead, however, you should evaluate your system design. If at all possible,

you should organize your files in such a way that the normal RPG II logic can determine the appropriate order of file processing. In this way, you do not have to code additional specifications to control the order. Of course, from time to time you may have jobs in which you must use FORCE and look-ahead.

### Doing Matching Records Without Match Fields

If two files are organized such that the same match fields cannot be assigned to the two files, you can still process the matching records together by using look-ahead fields and the FORCE operation. (This cannot be done, however, if the look-ahead file is defined as a combined or update file.) Look-ahead can be used to determine if certain fields (not assigned as match fields) on an unprocessed record match those on the record being processed. If they match, FORCE is performed to cause the matching unprocessed record to be selected next.

As an example, assume a report is to be prepared showing the amount of each salesman's sales and his quota. The report should also compare the total of district sales with the district quota.

The two files available for this program are described in Figure 7-13. The primary file (MASTER) contains a district record (record type 01), followed by all salesmen's MASTER

Line		Form Type	Filename	Sequence	Record Identification Codes	Field Location	Field Name	Field Indicators
1	2	3	4	5	6	7	8	9
10	11	12	13	14	15	16	17	18
19	20	21	22	23	24	25	26	27
28	29	30	31	32	33	34	35	36
37	38	39	40	41	42	43	44	45
46	47	48	49	50	51	52	53	54
55	56	57	58	59	60	61	62	63
64	65	66	67	68	69	70	71	72
73	74	75	76	77	78	79	80	81
01	I	MASTER	011	01	1	CD		
02	I						3 50DSTNUM	} District record
03	I						7 122DQUOTA	
04	I						13 28 DSTMGR	
05	I		02N	02	1	CM		
06	I						3 50DSTNUM	} Salesman master record
07	I						6 90MANNUM	
08	I						10 25 NAME	
09	I						27 322QUOTA	
10	I*							
11	I	SALES	AA	03	1	CS		
12	I						6 90MANNUM	} SALES record
13	I						12 172AMOUNT	

Figure 7-13. Describing Files to be Matched Without Match Fields

records (type 02) associated with the district. These are in turn followed by the next district record (01) and its related salesman MASTER records (02) and so on. Although the records are grouped by district, all salesman MASTER records in the file are still in ascending sequence by salesman number. The secondary file (SALES) contains only one record type (03), a record for each individual sale. The SALES file is also in ascending sequence by salesman number. While the MASTER file contains a record for every salesman (assume there are no MASTER records missing), the SALES file may contain only one, several, or even no records for a particular salesman.

To produce the report, the records should be processed in the following order:

1. District record (record type 01).
2. Salesman MASTER record (record type 02).
3. All SALES records for that salesman (record type 03).
4. Next salesman MASTER record.
5. SALES records for that salesman.
6. Next district record (after all salesman MASTER records associated with the first district have been processed).

There is no common field on all three record types which can be assigned as a match field to cause the records to be processed in this order. Totals are to be accumulated by salesman number; but the MANNUM field is contained only on the salesman MASTER and SALES records. The district records do not contain this information.

If the MANNUM fields are assigned as M1 match fields for only two of the record types, the records will be processed in an incorrect order. Following the last salesman MASTER record (02 record type) for a particular district, the next record in the same file is another district card. Since district records have no M1 match field entry assigned (no MANNUM field), the district record is processed immediately before the SALES records for the last salesman.

Although this program cannot be done using match fields, you can match the records yourself by using the look-ahead capability to compare fields (Figure 7-14). The object is to match a salesman's SALES record with this salesman MASTER record. Thus, the MANNUM field on a SALES record is defined as a look-ahead field. While processing a salesman MASTER record, you then look ahead (in calculations) at the unprocessed SALES record to determine if

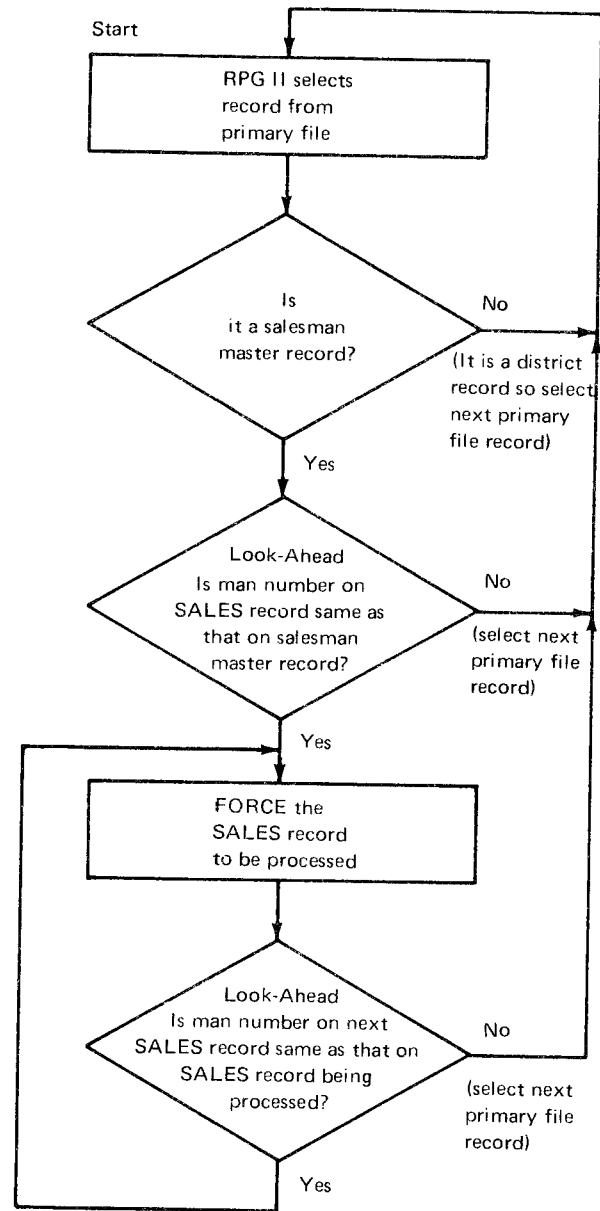

Figure 7-14. Using Look Ahead to Determine if Records Match

the salesman number is the same as on the record being processed. If they match, the FORCE operation code is used to process the SALES record as if RPG II logic were performing a matching records job. You then continue to force the rest of the SALES records which contain the same salesman number. For each record, look-ahead is used to check the MANNUM field to determine if the SALES record should be forced. When look-ahead indicates that the next SALES record is for a different salesman number, the SALES record is not forced. Instead, RPG II takes over to select the next primary file record which is either another salesman MASTER record or the next district record.



*Processing a Primary, Then Matching Secondary Records Before Matching Primary Records*

Another reason for looking ahead to determine which record to process next is when you want to process the files in an order other than the usual order of matching record logic. In such cases, all files must have match fields. The match fields on the next records available for processing are looked at to determine which record will ordinarily be selected and, thus, if it is necessary to force a record instead.

To illustrate altering the order of matching record logic, let's consider a sample billing program in which the records are to be processed in a particular order. However, note that the example is presented only to show you why and how look-ahead fields are used to determine whether a particular file should be processed. Actually, the desired results could also be obtained by processing the records in a different

order using the normal RPG II logic. We are not necessarily suggesting that your files be organized in the same way for your billing purposes. In fact, it is possible that the files for the sample program could be organized in a different way such that look-ahead with FORCE would not be necessary to process the records in the desired order.

*Organization of the Files:* The two files for the billing application (Figure 7-16) can each contain two record types. The primary file (FIRST) contains a name and address record for every customer (record type 01) followed by the customer's charge record (record type 02) if any purchases were made during the month. The secondary file (SECOND) contains one record for every customer showing his previous balance (record type 03). If the customer is entitled to a discount, a record containing his discount rate follows the balance card. As you can see, both files are in ascending sequence according to a common match field containing the customer number.

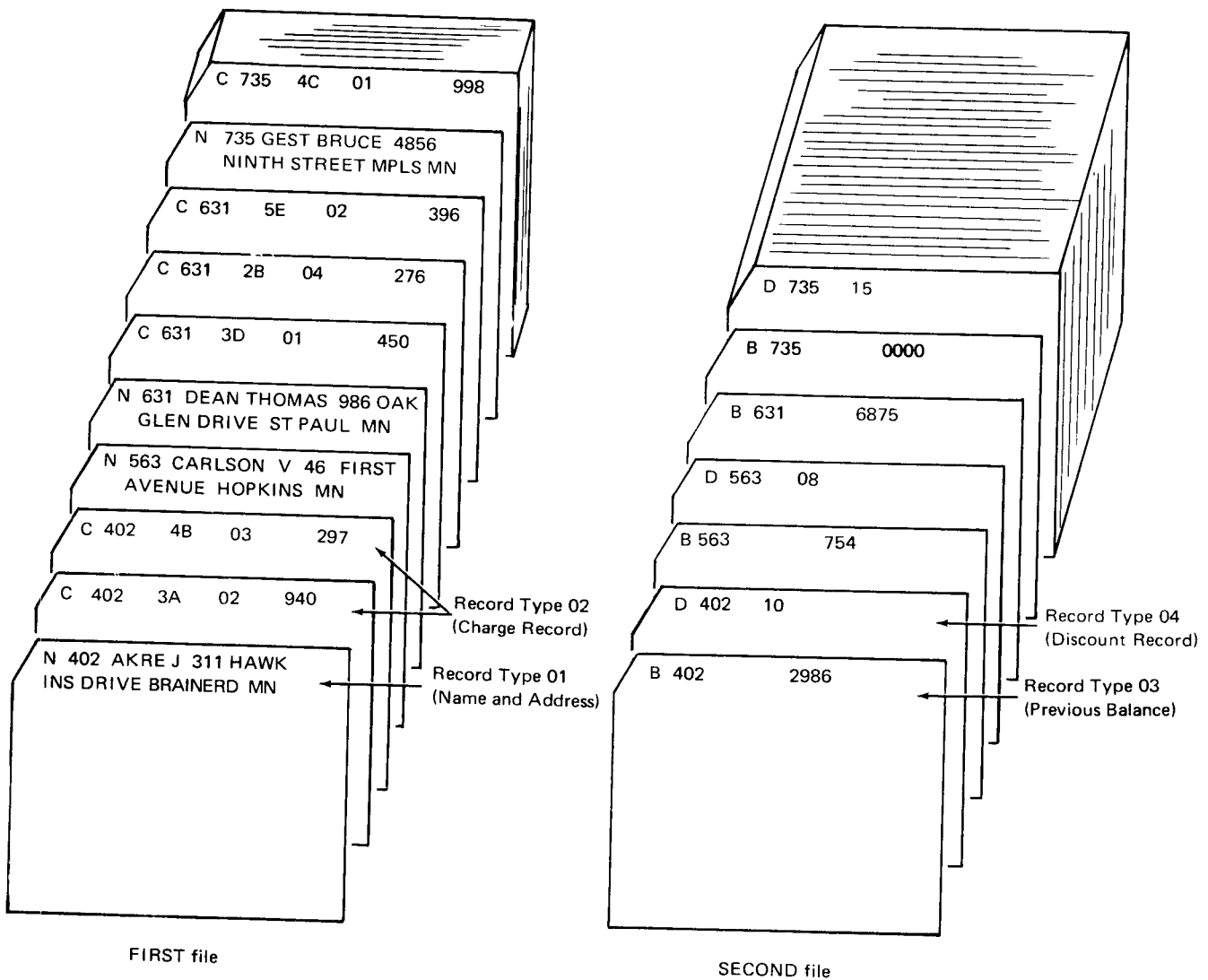

Figure 7-16. Files With More than One Matching Record



*Determining the Order of Processing:* To produce a bill, a customer's name and address are to be printed, followed by his previous balance (Figure 7-18). Any additional charges for the month are to be added to the previous balance to obtain a new balance. Some customers are entitled to a discount, which must be determined before adding the monthly charges to the previous balance.

If the two files are processed by RPG II logic according to matching records, all matching primary file records are processed before any matching secondary file records. In other words, first the name and address record is selected, followed by any charge records. Only after processing all the primary records for a particular customer are his balance and discount records processed.

Providing a customer has no charge records, the order of processing determined by RPG II is correct. That is, after the name and address record (the only primary record with the same match field), the balance record from the secondary file is processed. If there is a discount record with the same match field, it is then read, even though the discount data is not necessary when there are no charges.

On the other hand, for customers who have incurred charges, the order of processing the matching records must be altered. Instead of processing all matching primaries before the matching secondaries, only the first primary record is processed. The matching secondary records are then processed, followed by the remaining matching primary records.

*Determining When to Force A File:* The calculation and output specifications to process the records and print the bills are shown in Figure 7-19. For every customer group, the name and address record (record type 01) from the primary file is read first and printed at the top of the billing form. RPG II logic automatically selects this primary record as the first to be processed.

You want customer's balance record (record type 03) from the secondary file to be processed immediately after the name and address record. What you must determine then, while the name record (record type 01) is still being processed, is whether the balance record can be selected normally or if it must be forced. You know that if there is a charge record for this customer in the primary file, it has the same match field as the name and address record. Furthermore, if there is a charge record with the same match field, this record will be selected for processing rather than the secondary file balance record. Thus, while processing the name record, you must look-ahead at the next available primary record to determine if its match field is the same as the match field of the record being processed. To do this, line 01 of the calculation specifications (Figure 7-19) compares

the look-ahead match field (NXTNUM) on the primary file record not yet available to the match field (CUSNUM) on the name record being processed. If the fields are equal (indicator 21 set on), you must force the balance record (line 02 of Calculation sheet).

While the balance record is being processed, you must determine from which file the next record is to be processed. To do this, calculation line 05 is performed. If there is a discount record in the secondary file for this customer, the match field on the next available secondary file record will be equal to the match field on the balance record being processed. Thus, the look-ahead match field (NXTCST) for the secondary file is compared to the balance record match field. If equal, indicator 22 is set on, indicating the next available secondary record (a discount record) should be processed. Whether to force the discount record depends on whether there are still primary file records which match. If there were charge records in the primary file, the balance record being processed was forced and, thus, indicator 21 is still on.

ABC COMPANY		DATE 10-25-68	
AKRE J 311 HAWKINS DRIVE BRainerd MN			
ITEM	QTY	CHARGE	PREV. BALANCE \$ 29.86
3A	02	8.46	
4B	03	2.67	
BALANCE DUE			\$ 40.99
-----			
ABC COMPANY		DATE 10-25-68	
CARLSON V 46 FIRST AVENUE HOPKINS MN			
ITEM	QTY	CHARGE	PREV. BALANCE \$ 7.54

Figure 7-18. Bill Showing Order in Which Data Must be Printed

### RPG CALCULATION SPECIFICATIONS

Form GX21 9093  
Printed in U.S.A.

Program		Punching Instruction	Graphic	Card Electro Number	Page 1 of 2	Program Identification	75 76 77 78 79 80
Programmer		Date	Punch				

Line	Form Type	Indicators						Factor 1	Operation	Factor 2	Result Field		Resulting Indicators	Comments
		And	And	Not	Not	Not	Not				Name	Length		
01	C	Ø1					CUSNUM	COMP	NXTNUM				21 IS THERE A CHG	
02	C	Ø1	Ø1					FORCE	SECOND				RECORD? IF YES,	
03	C*												FORCE BALNC REC	
04	C*													
05	C	Ø3					CNUMBR	COMP	NXTCST				22 IS THERE A DSCT	
06	C	Ø3	Ø1	Ø2				FORCE	SECOND				REC? YES-FORCE	
07	C*												AFTER BALNC REC	
08	C*												IF BALNC FORCED	
09	C*													
10	C	Ø2	Ø2				CHARGE	MULT	DSRATE	DSCNT	32H		IF DSCNT RECORD	
11	C	Ø2	Ø2				CHARGE	SUB	DSCNT	CHARGE	32		READ, CALCULATE	
12	C*												DISCOUNT CHARGE	
13	C	Ø2					BALNCE	ADD	CHARGE	BALNCE	42		ADD TO PREV BAL	
14	C													

### RPG OUTPUT SPECIFICATIONS

GX21 9090 2 U/M 0507  
Printed in U.S.A.

Program		Punching Instruction	Graphic	Card Electro Number	Page 1 of 2	Program Identification	75 76 77 78 79 80
Programmer		Date	Punch				

Line	Form Type	Filename	TYPE (H/D/T/E)		Space	Skip	Output Indicators			Field Name	End Position in Output Record	PBLR	Comments
			A	D			Before	Alter	Not				
01	O	BILLS	D		Ø5		Ø1				21	} Print name, address, and date	
02	O								NAME	44			
03	O								UMONTH	47			
04	O								UDAY	50			
05	O								UYEAR	50			
06	O		D		Ø1				STREET	25	} Print previous balance		
07	O												
08	O		D		Ø3				CTYSTA	20			
09	O		D		Ø3				BALNCEJ	60	} Print monthly charges		
10	O												
11	O		D		Ø2				ITEM	8	} Print accumulated new balance when name and address record for next customer is read		
12	O								QTY	20			
13	O								CHARGEJ	35			
14	O		T		Ø6	Ø1			BALNCEJB	60			
15	O												
16	O												
17	O												
18	O												
19	O												
20	O												

● Figure 7-19. Specifications for Processing Matching Secondary Records Before Matching Primary Records



The FORCE of a discount record on calculation line 06 is conditioned, then, by two resulting indicators: 22 on means there is a discount record to be processed and 21 on means that the discount record must be forced since the balance record was forced.

After determining which file is to be processed next and, then, whether that file is to be forced, output processing continues for the record being processed. That is, the balance is printed on the bill.

Providing a discount record is present, this record is processed next. No calculations and output are performed for this record, however. The discount rate (DSRATE) is merely stored so that data can be used to calculate discounts when charge records are processed.

In the next program cycle, RPG II logic determines which record to process next. If there is a charge record in the primary file, this record is selected since its match field is the same as the match field on the previously processed record.

When a charge record (record type 02) is selected, the first step is to determine if the charge is to be discounted. If a discount record was processed for this customer, indicator 22 is still on. Thus, the calculations on lines 10-11 are performed only if 22 is on. The charge, whether discounted or not, is then added to the previous balance to accumulate a new balance (line 13). The individual charge is then printed and any remaining charge records are processed in the same way.

When all charge records for this match group are processed, a name and address record for the next customer is available in the primary file, while his balance record is in the secondary file. As before, since both records match, RPG II logic selects the primary file name record to process first.

Referring to the input specifications for this program, the customer number field on the name record was assigned as a control field, as well as a match field (see Figure 7-17). Since the customer number on the name record just selected differs from that on the previous name record, a control break occurs. Before processing the name record for the second customer, then, total operations for the previous group are performed. Thus, the output specifications in Figure 7-19, line 13, cause the new balance (which has been accumulating for every charge record processed) to be printed on the customer's bill.

### *Effect of Forcing on the MR Indicator*

In this last example, we assumed that for every customer, there is at least one record in the primary file (name record) and one record in the secondary file (balance record). For every record processed then, there exists a matching record in the other file.

Although a matching record condition actually exists for all records, the MR indicator is not necessarily turned on for every record. When RPG II logic selects records in the usual order, the MR indicator is on during the processing of these records. However, MR is never turned on for a record which is forced. If a file is to be forced, the RPG II logic doesn't even compare the two files and, thus, doesn't determine if a matching record condition exists. A forced record is processed, then, as if it contained no match fields.

The last example did not require that any calculations or output be conditioned on the basis of matching records. Nevertheless, you must be aware of the effect forcing has on the MR indicator so you won't incorrectly think MR is on when it is actually off.

## **PROCESSING DEMAND FILES (READ OPERATION)**

Using the FORCE operation, you can override normal RPG II logic for selecting records on the *next* program cycle. Suppose, however, you want to select records to be processed during the *current* program cycle. For example, a company maintains a file of employee numbers, NUMBRFLE. Each number is on a separate record (Figure 7-20). Those records containing numbers that are already assigned to employees are identified by a flag (character X in position 8 of the record). If the number has not been assigned to an employee, the record does not have a flag.

For each record that is read from the file of new employee records, NEWNAME (Figure 7-20), one or more records must be read from NUMBRFLE to find a number that can be assigned to the new employee. The new number must be found during the current cycle, since the new employee record is added to the employee master file, NAMEFILE (Figure 7-20), after a number is assigned.

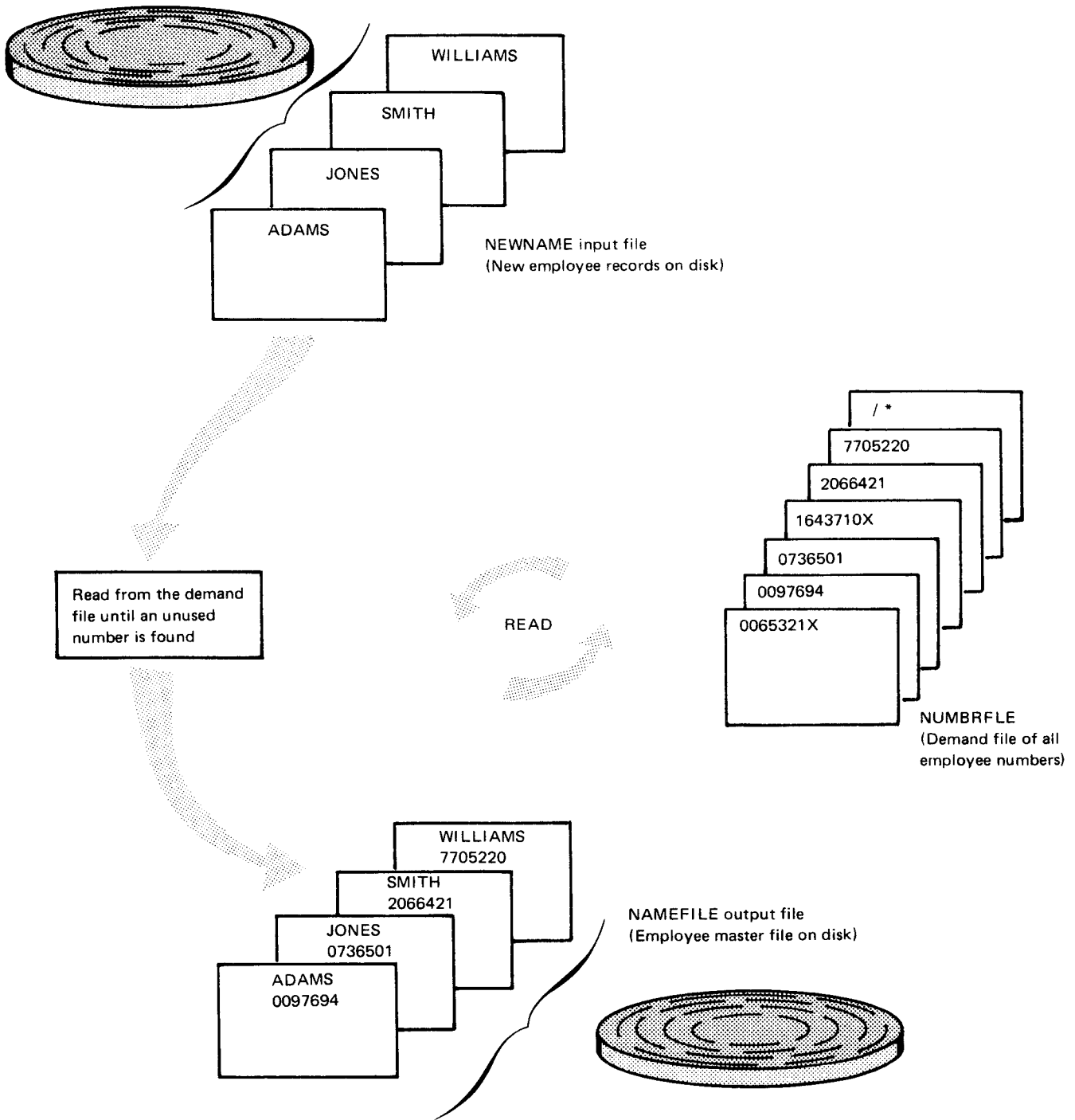

Figure 7-20. Using the READ Operation and a Demand File to Assign Man Numbers to New Employees

By designating NUMBRFLE as a demand file (Figure 7-21, insert A) you can request input from the file as many times as necessary during a single program cycle. In order to request input, you must use the READ operation code in the calculation portion of your program (Figure 7-21, insert C). Each time a READ operation is done, a record is read from NUMBRFLE.

It is possible that end of file for the demand file could be reached during a program cycle. Two options are available to handle this situation. In the example (Figure 7-21, insert C), an indicator has been entered in columns 58-59. An indicator specified in columns 58-59 of the specification line

containing the READ operation will turn on after each READ operation if an end of file condition is reached. In the example, new employee records are listed on the printer as they are added to NAMEFILE. If end of file is reached on NUMBRFLE before numbers have been assigned to all new employees, indicator 77 is turned on and the new employee records to which numbers have not been assigned are listed with an appropriate identification.

If an end of file indicator is not entered in columns 58-59, the program will halt when end of file is reached on the demand file and each time READ is executed thereafter.

### File Description Specification

Line	Form Type	Filename	File Type		Mode of Processing		Device	Symbolic Device	Label S/N/E/W	Name of Label Exit	Extent Exit for DAM	File Addition/Unordered	
			File Designation	Sequence	Length of Key Field or of Record Address Field	Record Address Type						Number of Tracks for Cylinder Overflow	Number of Extents
0 2	F	NEWNAME	F	96	96		MFCUL						
0 3	F	NUMBRFLE	F	256	8		DISK						
0 4	F	NAMEFILE	F	256	128	7AT	DISK						
(A)	F	NAMELIST	F	128	128	OV	PRINTER						

A D in column 16 identifies an input, update, or combined file as a demand file.

Other devices can be used, depending on the system and configuration

---

### RPG INPUT SPECIFICATIONS

IBM International Business Machine Corporation

GX21 9094 U/M 0501  
Printed in U.S.A.

Program	Punching Instruction	Graphic	Card Electro Number	Page 1 of 2	Program Identification
Programmer	Date	Punch			

Line	Form Type	Filename	Sequence	Number (I/N) Option (O)	Record Identifying Indicator	Record Identification Codes									Field Location		Field Name	Field Indicators		
						1	2	3	From	To	Plus	Minus	Zero or Blank							
0 1	I	NEWNAME	NS																	
0 2	I	NUMBRFLE	NS																	
0 3	I	NUMBRFLE	NS																	
(B)	I																			

Figure 7-21 (Part 1 of 2). Coding to Use a Demand File to Assign Man Numbers to New Employees

**RPG CALCULATION SPECIFICATIONS**

Form GX21-9093  
Printed in U.S.A.

IBM International Business Machine Corporation

Program: \_\_\_\_\_ Card Electro Number: \_\_\_\_\_  
 Programmer: \_\_\_\_\_ Date: \_\_\_\_\_ Punching Instruction: \_\_\_\_\_ Graphic: \_\_\_\_\_ Punch: \_\_\_\_\_

Page 03 of 75 76 77 78 79 80  
 Program Identification: \_\_\_\_\_

Line	Form Type Control Level (L, O, L, G, L, R, SR, AN, OR)	Indicators						Factor 1	Operation	Factor 2	Result Field	
		And	And	Not	Not	Not	Not				Name	Len
01	C							LOOP	TAG			
02	C								READ NUMBRFLE			77
03	C								GOTO LOOP			
04	C							N88N77	MOVE 'X'		FLAG	
05	C							N77				

The indicator in columns 58-59 of a READ specification will turn on each time READ encounters an end-of-file condition in the demand file. If no indicator is used, the program halts each time end-of-file is encountered.

**RPG OUTPUT SPECIFICATIONS**

GX21-9090 U/M 050\*  
Printed in U.S.A.

IBM International Business Machine Corporation

Program: \_\_\_\_\_ Card Electro Number: \_\_\_\_\_  
 Programmer: \_\_\_\_\_ Date: \_\_\_\_\_ Punching Instruction: \_\_\_\_\_ Graphic: \_\_\_\_\_ Punch: \_\_\_\_\_

Page \_\_\_\_\_ of \_\_\_\_\_ Program Identification: \_\_\_\_\_

Line	Form Type	Filename	Type (H/D/T/E)		Space	Skip	Output Indicators		Edit Codes B/C/D/S/R	End Position in Output Record	P/B/L/R	Constant or Edit Word								
			A	R			Commas	Zeros to Print				No Sign	CR	-	X	Remove Plus Sign				
01	O	NAMEFILEDADD																		
02	O																			
03	O																			
04	O	NUMBRFLED																		
05	O																			
06	O	NAMELISTH			306															
07	O	OR																		
08	O																			
09	O																			
10	O																			
11	O																			
12	O																			
13	O																			
14	O																			
15	O																			
16	O																			
17	O																			
18	O																			
19	O																			
20	O																			

The end-of-file indicator can be used to condition operations which should or should not be done when the demand file is at end of file.

Figure 7-21 (Part 2 of 2). Coding to Use a Demand File to Assign Man Numbers to New Employees

## Considerations for Using READ and Demand Files

The following files can appear as Factor 2 in a READ operation (all must be designated demand files with a D in column 16 of the File Description sheet):

1. Sequential disk files processed consecutively and specified as input or update files.
2. Indexed disk files processed sequentially by key and specified as input or update files.
3. Indexed disk files processed sequentially within limits and specified as input or update files.
4. Direct disk files processed consecutively as input or update files.
5. Console and CRT files specified as input files.
6. Card files specified as input or combined files.
7. Ledger card files specified as input or combined files.
8. Data recorder files specified as input files.
9. Tape input files.
10. SIOC input and update files (SPECIAL device).
11. Teleprocessing input and combined files (BSCA device).
12. Device independent input files.

When using the READ operation for demand files remember:

1. Demand files (except those assigned to the Model 6 KEYBOARD) can only be processed by the READ operation.
2. Control levels, matching fields, and look-ahead fields are not allowed with demand files.
3. Numeric sequence testing on the Input sheet is not allowed for demand files.
4. The MR indicator may not be entered in columns 63-64 (Field Record Relation) on the Input sheet.
5. When a demand file is conditioned by a U1-U8 indicator which is not on, no records will be read from that file and the end-of-file indicator in columns 58-59 will not turn on.

6. When reading from several demand files during the same RPG II cycle, record identifying indicators assigned to the demand files will remain on throughout the cycle if the previous READ operations were executed successfully.

## REPETITIVE OUTPUT (EXCPT OPERATION)

RPG II has a special operation code called EXCPT which allows you to write or punch as many records as are required during one program cycle.

Normally a record is written or punched at either detail or total *output* time. Using EXCPT, records can be put out during detail or total *calculation* time. Each time you use the operation code EXCPT, specified records are written immediately. For example, if you use eight EXCPT operation codes in succession, you can get an exception output cycle eight times. The records are identical if the data fields in the exception records are not altered between the EXCPT operation codes on the Calculation sheet.

When you use the EXCPT operation code, you also must specify which records are to be put out during calculation time. These records are identified by an *E* in column 15 of the Output-Format sheet. Only those output lines identified by an *E* will be put out during an exception output cycle.

## Using EXCPT and \*PLACE

The reserved word \*PLACE duplicates fields and places them on the same line. In the discussion of \*PLACE in Chapter 3, an example is used in which three mailing labels were printed for each customer using \*PLACE. If you wanted to print 15 labels for each customer, however, you could not use only the reserved word \*PLACE. The only way would be to print the same three mailing labels five times in succession.

In the RPG II program cycle, each record specified is written or punched only *once* per cycle. For each record read by the program shown in Figure 7-22, the detail line specified in lines 01-04 is written only once. Remember that the \*PLACE entry causes the field to be duplicated. Using \*PLACE one line is printed with three identical names. The same is true for each of the other records specified. If you want to print 15 identical mailing labels, you need all records printed five times each.

# RPG OUTPUT SPECIFICATIONS

GX21 9090 U/M 050  
Printed in U.S.A.

**IBM** International Business Machine Corporation

Program	Date	Punching Instruction	Graphic	Card Electro Number	Page 1 of 2	Program Identification 75 76 77 78 79 80
Programmer			Punch			

Line	Form Type	Filename	Type (H/D/T/E)	Stacker # / Fetch (F)	Space	Skip	Output Indicators						Field Name	End Position in Output Record	Constant or Edit Word
							Before	After	Not	And	And	Not			
01	O	PRINT	D	32											
02	O											NAME	35		
03	O											*PLACE	75		
04	O											*PLACE	115		
05	O		D	2								ADDR	35		
06	O											*PLACE	75		
07	O											*PLACE	115		
08	O														
09	O		D	2								CITY	28		
10	O											STATE	35		
11	O											*PLACE	75		
12	O											*PLACE	115		
13	O														
14	O		D	3								ZIP	35		
15	O											*PLACE	75		
16	O											*PLACE	115		
17	O														
18	O														
19	O														
20	O														

Commas	Zero Balances to Print	No Sign	CR	X
Yes	Yes	1	A	J
Yes	No	2	B	K
No	Yes	3	C	L
No	No	4	D	M

X = Remove Plus Sign  
Y = Date Field Edit  
Z = Zero Suppress

Figure 7-22. Detail Output Operations

### RPG CALCULATION SPECIFICATIONS

Program	Punching Instruction	Graphic	Card Electro Number
Programmer	Date	Punch	

Page	1	2	of	
Program Identification				75 76 77 78 79 80

Line	Form Type	Control Level (L0, L9, LR, SR, AN/OR)	Indicators			Factor 1	Operation	Factor 2	Result Field		Resulting Indicators	Comments
			And	And	Not				Name	Length		
0 1	C									Arithmetic		
0 2	C									Plus Minus Zero		
0 3	C									Compare		
0 4	C									1 > 2   1 < 2   1 = 2		

Each time EXCPT is executed, the four output lines identified by an E in column 15 are written

### RPG OUTPUT SPECIFICATIONS

Program	Punching Instruction	Graphic	Card Electro Number
Programmer	Date	Punch	

Page	1	2	of	
Program Identification				75 76 77 78 79 80

Line	Form Type	Filename	Type (H/D/T/E)		Space	Skip	Output Indicators			Field Name	End Position in Output Record	Constant or Edit Word
			Stacker # / Fetch(F)	Before			After	And	And			
0 1	O	PRINT	E		32							
0 2	O								NAME	35		
0 3	O								*PLACE	75		
0 4	O								*PLACE	115		
0 5	O		E		2							
0 6	O								ADDR	35		
0 7	O								*PLACE	75		
0 8	O								*PLACE	115		
0 9	O		E		2							
1 0	O								CITY	28		
1 1	O								STATE	35		
1 2	O								*PLACE	75		
1 3	O								*PLACE	115		
1 4	O		E		3							
1 5	O								ZIP	35		
1 6	O								*PLACE	75		
1 7	O								*PLACE	115		

Figure 7-23. EXCPT Operation Code Used with Exception Records

Figure 7-23 shows the specifications necessary to print 15 mailing labels per customer. The \*PLACE specifications on the Output-Format sheet will cause three mailing labels to be printed side by side on the paper. Each EXCPT code used on the Calculation sheet causes all records identified by an *E* in column 15 of the Output-Format sheet to be printed one time in the order shown on the sheet. Because all four lines are to be printed on the mailing label, all are identified by an *E*. The five EXCPT codes will cause five rows of three mailing labels each to be printed.

Another set will not be printed at detail output time, because all records having an *E* in column 15 can be printed only at calculation time when the EXCPT operation code is encountered.

EXCPT can be used with punched cards or disk as well as printed output. It operates in the same way in all cases. Each time the EXCPT code is encountered, output lines identified by an *E* in column 15 are executed.

Only output files may have EXCPT records specified; EXCPT cannot be used for combined files.

### Conditioning the Use of EXCPT Operation

There are two ways you can condition an EXCPT operation: (1) on the Calculation sheet; and (2) on the Output-Format sheet.

The EXCPT operation can be conditioned on the Calculation sheet in the same way as any other operation. As shown in Figure 7-24, the EXCPT records are put out only when MR is on.

An indicator used on the Calculation sheet controls the printing or punching of all EXCPT records. Individual EXCPT records are controlled by indicators specified in columns 23-31 of the Output-Format sheet. These indicators are used in the same way for EXCPT records as they are for all other records.

**Restriction:** Overflow indicators cannot be used to condition an EXCPT line. This means that an EXCPT record cannot be a record that is printed only when the end of the page has been reached.

Remember, these lines are exceptions. They print only at calculation time, not at output time. Therefore, they could not possibly be printed when other overflow lines are.

An EXCPT line may be, however, printed on the overflow line. If it is, the overflow indicator will be turned on as usual. EXCPT lines can even *fetch* overflow. You may place an *F* in column 16 of any exception line. If the overflow indicator is on when the EXCPT line having an *F* in column 16 is reached, all lines conditioned by the overflow indicator will be printed before the exception line is printed.

C		Form Type		Control Level (LD, LG, LP, SP, AN/OR)		Indicators		Factor 1		Operation		Factor 2		Result Field		Resulting Indicators		Comments	
Line						And	And							Name	Length	Decimal Positions	Plus	Minus	Zero
0 1	C								COST		ADD	TOTAL		TOTAL					
0 2	C					MR					EXCPT								
0 3	C																		
0 4	C																		
0 5	C																		

Figure 7-24. Conditioning the EXCPT Operation Code









**EXCPT**

7. What occurs when the EXCPT operation code is executed?
8. In a program, you need to punch a specified number of cards for each item. This number will be punched in each input card. Refer to the coded Input sheet for record layouts and code the Calculation and Output-Format sheets for the program.

**IBM** International Business Machine Corporation

GX21-9094 U/M 050\*  
Printed in U.S.A.

**RPG INPUT SPECIFICATIONS**

Program \_\_\_\_\_

Punching Instruction: Graphic  Punch

Card Electro Number \_\_\_\_\_

Page  of

Program Identification:

Line	Form Type	Filename	Sequence	Number (1-N)	Option (O)	Record Identifying Indicator	Record Identification Codes									Field Location				Field Name	Control Level (L1-L9)	Matching Fields or Chaining Fields	Field Record Relation	Field Indicators			
							1			2			3			From	To	Decimal Positions	Plus					Minus	Zero or Blank		
							Position	Not (N) C/Z/D	Character	Position	Not (N) C/Z/D	Character	Position	Not (N) C/Z/D	Character											Strapper Select PB/L/R	
0 1	I	INFILE	AA	01		I	21	Not (N)	C/Z/D	Character	22	Not (N)	C/Z/D	Character	23	Not (N)	C/Z/D	Character	44	47	7	ITEMNO					
0 2	I																		44	51	80	NUMBER					
0 3	I																		44	51	96	CARD					
0 4	I																										
0 5	I																										
0 6	I																										
0 7	I																										
0 8	I																										
0 9	I																										
1 0	I																										
1 1	I																										
1 2	I																										
1 3	I																										
1 4	I																										
1 5	I																										
1 6	I																										
1 7	I																										
1 8	I																										
1 9	I																										
2 0	I																										
	I																										
	I																										
	I																										
	I																										
	I																										

## Answers To Review 7

1.
  - a. Match fields cannot be assigned to the files and you need to:
    - Alternate processing between two files.
    - Process a primary file record followed by a number of secondary file records.
    - Process a secondary file record only when it matches a primary file record.
  - b. Match fields are assigned to both files and you need to alter the order of matching record logic to process a primary file record, then matching secondary file records before matching primary file records.
2.
  - a. When each file must be processed and under which conditions.
  - b. Whether RPG II logic would select the appropriate record or if the file must be forced.
3. No action occurs at the time the specification is performed. At the beginning of the next program cycle, the next record from the file specified as Factor 2 of the FORCE operation is selected (by being forced) for processing.
4.
  - a. No, the specifications are incorrect.
  - b. A MASTER record will be processed in every program cycle until end of file is reached.
  - c. A COMMIS record will not be processed until all records in the MASTER file have been processed.
  - d. Lines 05 and 06 should not be conditioned by record identifying indicator 07. The COMP operation should be performed for every record type to determine if the FORCE is to be performed. It may be necessary to force a COMMIS record following either a MASTER record or another COMMIS record. For this reason, you must be able to perform the FORCE operation while processing either of the record types.
  - e. The FORCE operation is not necessary. The RPG II logic of matching records can determine the proper order of processing if the SLSNBR fields on each record type are assigned as match fields on the Input sheet.

5. Input specifications to define look-ahead field:

RPG INPUT SPECIFICATIONS																																								GX21-9094 L/M 050 Printed in U.S.A.		
<b>IBM</b> International Business Machine Corporation Program _____ Date _____ Programmer _____															Punching Instruction _____ Graphic _____ Punch _____					Card Electro Number _____ Page <u>1</u> of <u>2</u> Program Identification _____					75 76 77 78 79 80																	
I	Line	Form Type	Filename	Sequence			Record Identifying Indicator	Record Identification Codes									Field Location		Field Name	Control Level (L1-L9)	Matching Fields or Chaining Fields	Field Record Relation	Field Indicators																			
				O	R	A		1	2	3	From	To	Plus	Minus	Zero or Blank																											
				D	R	A		Position	Not [N]	C/Z/D	Character	Position	Not [N]	C/Z/D	Character	Position	Not [N]	C/Z/D	Character	P/B/L/R																						
	01	I	MASTER			AA	04	1		CZ																																
	02	I																				2		7	FLD1																	
	03	I																				8		12	FLD2																	
	04	I																				13		17	05LSMBR																	
	05	I																				18		38	NAME																	
	06	I	COMMIS			BB	07	1		CX																																
	07	I																				7		82	CMRATE																	
	08	I																				10		23	01MNUM																	
	09	I																				2		6	05LSNBR																	
	10	I				CC	**																																			
	11	I																				2		6	0NXTNBR																	
	12	I																																								

Calculation specifications to determine order of file processing:

RPG CALCULATION SPECIFICATIONS																																								Form GX21-9093 Printed in U.S.A.	
<b>IBM</b> International Business Machine Corporation Program _____ Date _____ Programmer _____															Punching Instruction _____ Graphic _____ Punch _____					Card Electro Number _____ Page <u>1</u> of <u>2</u> Program Identification _____					75 76 77 78 79 80																
C	Line	Form Type	Control Level (L0-L9, LR, SP, AN/OP)	Indicators			Factor 1	Operation	Factor 2	Result Field		Resulting Indicators	Comments																												
				And	And	Not				Name	Length			Arithmetic																											
				Not	Not	Not								Plus	Minus	Zero																									
	01	C				NXTNBR	COMP	SLSNBR				21	LOOKAT COMM REC																												
	02	C			21							21	SAME- FORCE																												
	03	C	*																																						
	04	C	*		21	ON	MEANS	THE	NEXT	COMMISSION	RECORD		IS	FOR	THE	CURRENT	SALESMAN																								
	05	C	*			AND	MUST	BE	PROCESSED	BEFORE	ANOTHER		MASTER	RECORD																											
	06	C																																							

If match field entries had been assigned to the SLSNBR fields on the Input sheet, input specification lines 10 and 11 would not be necessary to define the look-ahead field. No calculation specifications would be required to determine the order of processing.

6.
  - a. A demand file is processed only by the READ operation code during calculations. Demand file records are never selected by normal RPG II multfile logic.
  - b. Match fields cannot be assigned to a demand file.
  - c. Look-ahead fields cannot be defined for a demand file.
  - d. Reading an end of file record (/\*) from a demand file does not set the LR indicator on. Instead, an end of file indicator can be entered in columns 58-59 of the READ specification line. This indicator will turn on each time a READ is executed which encounters an end of file condition in the demand file.
7. Immediate output for specified records occurs. These records are coded as exception records by an E in column 15 of the Output-Format sheet.
8. See Specification sheets.

IBM International Business Machine Corporation		<b>RPG CALCULATION SPECIFICATIONS</b>										Form GX21-9093 Printed in U.S.A.					
Program		Punching Instruction	Graphic						Card Electro Number	Page <span style="border: 1px solid black; padding: 2px;">1 2</span> of <span style="border: 1px solid black; padding: 2px;">75 76 77 78 79 80</span>		Program Identification <span style="border: 1px solid black; padding: 2px;">75 76 77 78 79 80</span>					
Programmer		Date	Punch														
C Line	Form Type	Control Level (LQ,LR,LR,S,AN,OP)	Indicators					Factor 1	Operation	Factor 2	Result Field		Resulting Indicators			Comments	
			And	And	Not	Not	Not				Name	Length	Arithmetic	Plus	Minus		Zero
3																	
0 1	C						START	TAG									
0 2	C							EXCPT									
0 3	C							SLB 1		NUMBER							
0 4	C							GOTO START									
0 5	C																
0 6	C																
0 7	C																

IBM International Business Machine Corporation		<b>RPG OUTPUT SPECIFICATIONS</b>										GX21-9090 2 U/M 050* Printed in U.S.A.											
Program		Punching Instruction	Graphic						Card Electro Number	Page <span style="border: 1px solid black; padding: 2px;">1 2</span> of <span style="border: 1px solid black; padding: 2px;">75 76 77 78 79 80</span>		Program Identification <span style="border: 1px solid black; padding: 2px;">75 76 77 78 79 80</span>											
Programmer		Date	Punch																				
O Line	Form Type	Filename	Type (H/D/I/EI)		Space		Skip		Output Indicators			Field Name	Edit Codes B/A/C/I/S/R	End Position in Output Record	P/B/L/R	Constant or Edit Word							
			Before	After	Before	After	Not	Not	Not	Commas	Zero Balances to Print					No Sign	CR	-	X	Y	Z		
0 1	O	CARDS										*AUTO					Yes	Yes	1	A	J	X - Remove Plus Sign	
0 2	O	ET															Yes	No	2	B	K	Y - Date Field Edit	
0 3	O																No	Yes	3	C	L	Z = Zero Suppress	
0 4	O																No	No	4	D	M		

**CHAPTER 8 DESCRIBES:**

Uses for tables.

RPG II coding used to search tables.

Designing table input records.

LOKUP operation code.

Use of table data in calculations and output operations.

**BEFORE READING THIS CHAPTER YOU SHOULD BE ABLE TO DESCRIBE:**

RPG II object cycle.

Matching records processing.

Use of indicators to condition operations.

**AFTER READING THIS CHAPTER YOU SHOULD BE ABLE TO:**

State uses for tables.

Define a table on the Extension sheet.

Code problems using a single table.

Code problems using related tables.

Define and code the LOKUP operation code with tables.

Describe data and store it in a table.

*Note:* You can use the review questions contained in *Review 8* at the end of this chapter to test your comprehension of the chapter. Answers follow the review questions.



## INTRODUCTION

If you wish to make a telephone call to a person, you must first determine his telephone number. Imagine trying to obtain the number if no telephone directories were available! For such reasons, similar items of information are grouped and organized so they can be referenced easily and quickly.

A *table* is a collection of related data organized in such a way that each item of information can be referenced by its position within the table. A telephone directory consists of two tables of information: a name list arranged alphabetically and a number list arranged in no apparent order. Each telephone number, however, occupies a position in the number list corresponding to the position of a particular name in the name list.

Each item within a table is called a table *element*. Thus, each name would be an element of the name table, while each number would be an element of the telephone number table.

If you wished to determine Ken Adams' telephone number, you would look through the list of names to locate *KEN ADAMS*. This procedure of checking the elements of a table one at a time to find a particular entry is called *searching a table*. Before looking through the name list, you must know what information you wish to find, the name *KEN ADAMS*. This data is referred to as the *search word*.

As shown in Figure 8-1, the name list is searched to find an entry which is equal to the search word. The matching entry, *KEN ADAMS*, is found in the third element of the name table. His corresponding telephone number, then, is found by selecting the third element in the number table.

When two related tables are used, as in a telephone directory, actually only one table is searched (name table). When the search condition (in this case, an equal match) has been satisfied, the data in the corresponding element of the second table becomes available. Thus, the first table is used as a means of locating data in the second table.

A telephone directory is an example of tables which organize information that we must reference over and over again in our every day lives. Likewise, tables can be used to organize data which must be referenced repeatedly in your data processing jobs.

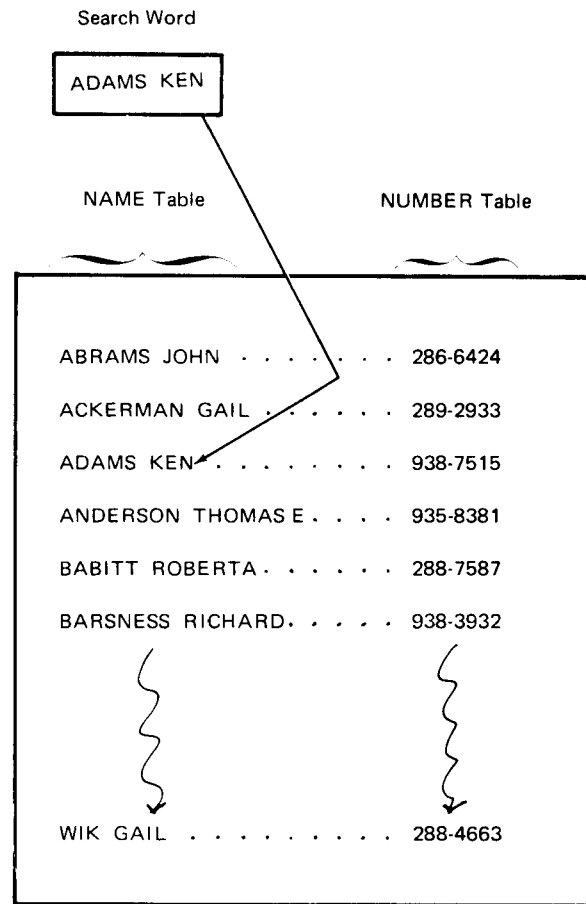

Figure 8-1. Searching a Table

Let's assume that customers have purchased various items from a company sales catalog. The sales file (Figure 8-2) would contain records showing the customer's account number (CUSTMR), the item ordered (ITMORD), identified by a code, and how many were ordered by that customer (QTYORD).

Furthermore, the company keeps an inventory file (Figure 8-2) to contain data about each item which is carried in stock. A separate record is kept for each item showing the item code (ITEM), the quantity on hand (QTYSTK), and the unit cost of each item (COST).

Before you can ship the customer's orders, you must first determine if the item ordered is still carried in stock. To do this, a clerk could spend time looking up each item ordered to see if that item is recorded in the inventory file. However, the same item will probably be ordered by many customers. Thus, the same inventory file records would have to be referenced over and over again.

**SALES File**

Record

1	S 4 5 6 7 8 9 A 8 7 1 5
2	S 2 7 5 6 3 1 C 6 5 2 7
3	S 3 4 6 7 2 4 C 8 9 6 3
4	S 5 6 9 8 2 3 B 8 3 3 7

CUSTMR                      QTYORD  
    ITMORD

**INVNTRY File**

Record

1	A 23      33      140
2	A 87      66      125
3	B 21      58      1623
4	B 83      46      209
5	C 4611017      109
6	C 65      896      150
7	C 72      70      2150
8	C 89      2500      110

ITEM                      COST  
    QTYSTK

Figure 8-2. Data for Determining if Orders Can be Filled

### Searching a Single Table

RPG II can search for the data in much less time by performing a table lookup function. As shown in Figure 8-3, a table (TABITM) would be set up in storage to contain all of the items available (see *Loading Tables* in this chapter for methods of loading table data into storage).

The second field of each sales record tells the program which item to *look up*. For every sales record read into the computer, TABITM is checked to see if the search word (item code on the sales record) matches an entry in the table.

In addition to searching for data quickly, use of the table lookup can often reduce the number of RPG II specifications needed in a program. All you must do is set up and define the table, and specify that the lookup operation is to be performed.

### Designing Table Input Records

Data used to create a table must be obtained from table input records. These records can be taken from the keyboard or CRT, punched cards, magnetic tape, or disk. The records are read by the computer and entries are placed side by side in storage to form the table.

The inventory file for this company indicates that 98 types of items are carried in stock. Therefore, the 98 item codes must be contained in table input records to provide the entries for TABITM.

#### *Number of Table Input Records Required for a Table*

How many records would be necessary to punch the 98 item codes? That is entirely up to you. The number of records required to contain the table data depends on the number of entries you want on each record.

#### *Number of Entries on a Table Input Record*

Table input records may either contain one entry or a number of entries. The point to remember is that all table input records for a single table must contain the same number of entries, except for the last record.

The use of one entry per record is very convenient if it is necessary that the entries be in a particular order. Then to add or delete entries, you merely add or remove a record. Otherwise, you would have to recreate all of the records from the point of change to the end of the table. However, in the TABITM table, item code entries need not be in order, so including a number of entries in each record reduces the number of records required.

For TABITM, 98 entries must be recorded on table input records. If 96-column cards are used, 32 entries fit on each record, since each item code is three characters long. Therefore, to save card space, you could punch three table input records containing 32 entries each and a fourth table input record for the remaining two entries. (See Figure 8-4.) In this way, all records contain the same number of entries except the last record.

Of course, you do not have to fill the entire record with entries, as we have done. For instance, you may want the last 36 columns of a card to contain no punches. In that case, you could punch 20 entries (card columns 1-60) into each of four table input records. The remaining 18 entries could then be punched into a fifth record.

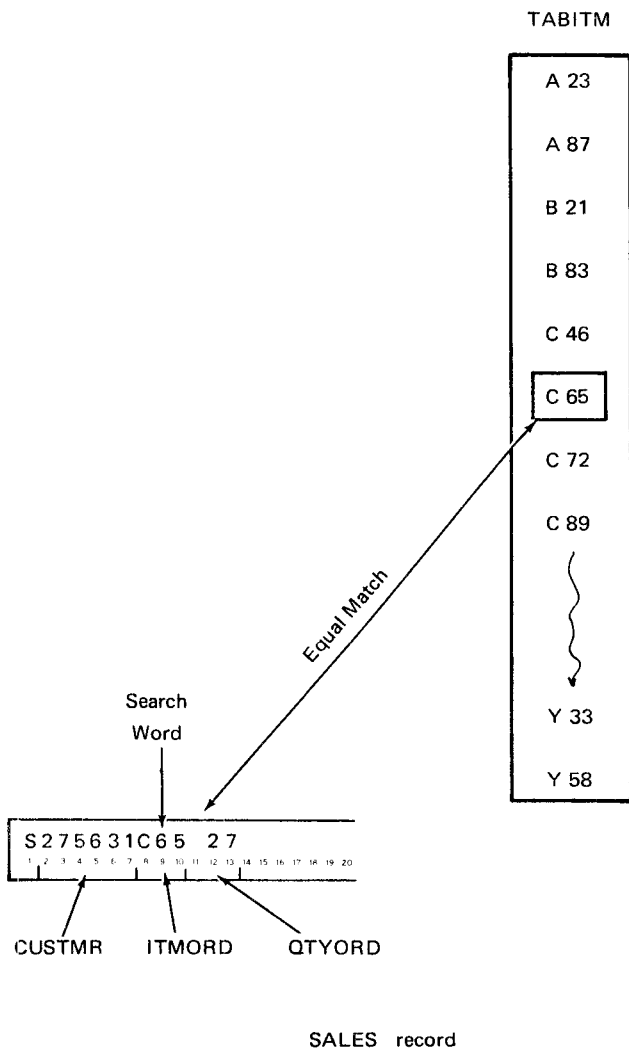
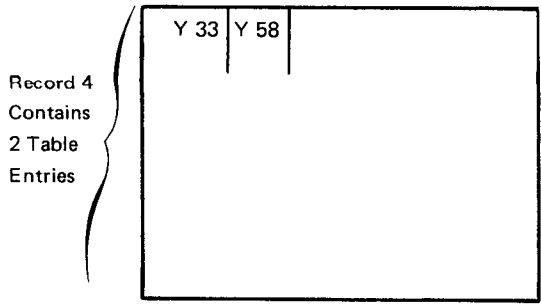

Figure 8-3. Searching a Table for a Particular Data Item



Notice in Figure 8-4 that the two entries in the fourth table input record are placed side by side. Since there are unused card columns on the record, why not space the entries? You cannot, because all entries *must* be continuous on the record, with no blank columns *between* entries. Furthermore, the first entry on each record must begin in position one.

**Describing Table Input Records with Extension Specifications**

Once the table input records have been designed, you then describe them to the RPG II Compiler program. Ordinarily, the data on input records is described by entering specifications on the Input sheet. However, you describe the data on table input records by coding extension specifications on the upper half of the Extension and Line Counter sheet. (Hereafter, we will refer to the upper portion of the form as the Extension sheet and the lower portion as the Line Counter sheet.)

Figure 8-5 shows the extension specifications needed to describe the table containing item codes. As you can see, a single table can be described using only columns 27-45. Of course, remember that the page and line number (columns 1-5) and form type (E in column 6) are also part of the entire specification line.

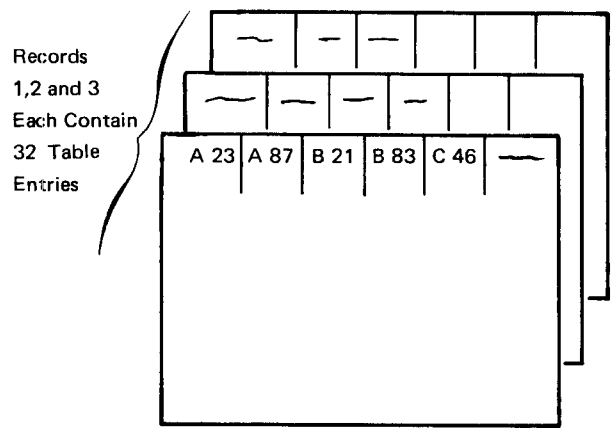

Figure 8-4. Four Table-Input Records for TABITM Entries

**RPG EXTENSION AND LINE COUNTER SPECIFICATIONS**

Form X21-9091  
Printed in U.S.A.

Program		Punching Instruction		Graphic		Card Electro Number	
Programmer		Date		Punch			

Page  of  Program Identification

**Extension Specifications**

Line	Form Type	Record Sequence of the Chaining File		To Filename	Table or Array Name	Number of Entries Per Record	Number of Entries Per Table or Array	Length of Entry	P/B/L/R	Decimal Positions Sequence (A/D)	Table or Array Name (Alternating Format)	Length of Entry	P/B/L/R	Decimal Positions Sequence (A/D)	Comments
		From Filename	Number of the Chaining Field												
01	E				TABITM	32	98	3							ITEM CODES IN STK
02	E														
03	E														
04	E														
05	E														
06	E														
07	E														
08	E														
	E														
	E														

Figure 8-5. Describing Table-Input Records

The extension specifications provide the following information about each table to be used:

1. Name of each table (columns 27-32).
2. Number of table entries per table input record (columns 33-35).
3. Number of table entries per table (columns 36-39).
4. Length of each entry (columns 40-42).
5. Whether packed or binary data is contained in the table (column 43).
6. Number of decimal positions in each numeric entry (column 44).
7. Sequence of table entries, if any (column 45).

Each type of entry will be discussed in turn. From Filename (columns 11-18), To Filename (columns 19-26), and the entries in columns 46-57 are described later in this chapter.

### *Assigning Table Names*

Every table used in a program must be assigned a name from three to six characters long. The table name may contain any combination of alphabetic characters and numbers. However, the first three characters of the name must be TAB.

With these points in mind, which of the following table names are *not* acceptable and why?

TABA	15ABCD
TAB C	TABSTATE
TB123	*TAB
TAB\$2	

TAB C and \*TAB are not acceptable, as table names cannot contain blanks or special characters, such as the \*. TAB\$2, on the other hand, is an acceptable table name, since \$ is one of the three special characters which can be considered an alphabetic character. (The other two are # and @.)

The names 15ABCD and TB123 are invalid because they do not begin with the alphabetic characters TAB. Since TABSTATE contains more than six characters, it cannot be an acceptable table name. TABA and TAB\$2 are the only two valid table names shown.

If possible, it is helpful to assign table names which are meaningful. For this example, the name TABITM has been assigned. Such a name gives an indication of what kind of data is contained in the table (in this case, item codes).

When a single table is being used, as in this case, the table name is entered in positions 27-32 of the Extension sheet (see Figure 8-5).

### *Number of Table Entries per Table Input Record*

The number of entries in each table input record is specified in columns 33-35. Figure 8-5 shows 32 entries per record for TABITM. In this way, the compiler program will expect all table input records to contain 32 entries, except the last record which may have fewer entries. Notice that the number entered in these columns should end in column 35.

### *Number of Table Entries Per Table*

The number of entries which can be contained in the entire table is entered in columns 36-39 of the Extension sheet. As shown in Figure 8-5, the number (98 for TABITM) should end in column 39.

### *Length of an Entry*

The length of each table entry is indicated in columns 40-42, with the number ending in column 42. Numeric table entries may be up to 15 digits long, while alphameric entries can be as long as the maximum record length for the device (256 maximum).

For TABITM, the length 3 has been entered. It is possible to specify only one length. Therefore, this necessarily means that all entries in a table must be the same length.

At this point, you may be wondering what to do if all entries are not the same length. For instance, you might wish to make a table containing the months of the year. The solution is simple — all entries are made to be the length of the longest entry. The word SEPTEMBER contains the most characters. Therefore, each entry should be 9 characters long. To make JUNE an entry with length of 9, you would place 5 blanks after the letter E (see Figure 8-6). Inserting extra blanks to lengthen the data entry is referred to as padding with blanks. If your table entries were numbers, instead of letters, you would pad the short entries with zeros or blanks. (For numeric entries, the zeros or blanks would probably be placed in front of the number.)

J	A	N	U	A	R	Y		
F	E	B	R	U	A	R	Y	
M	A	R	C	H				
A	P	R	I	L				
M	A	Y						
J	U	N	E					
J	U	L	Y					
A	U	G	U	S	T			
S	E	P	T	E	M	B	E	R
O	C	T	O	B	E	R		
N	O	V	E	M	B	E	R	
D	E	C	E	M	B	E	R	

← Longest Table Entry

Table Of Months

Figure 8-6. Making Table Entries the Same Length

Padding a table entry with blanks should not be confused with spacing entries on a record. As mentioned, no blanks can occur *between* entries. However, blanks can be part of an entry in order to make all entries the same length.

*Packed or Binary Table Data (Systems with Disk Storage)*

An entry must be made in column 43 if the data for a pre-execution time table is in packed decimal (P) or binary (B) format on disk or tape or in packed format on 80-column cards (not allowed on 96-column cards). This entry applies only to numeric tables. For numeric tables in packed decimal format, the unpacked decimal length of the entries must be entered in columns 40-42 (Length of Entry). For numeric tables in binary format, enter the number of bytes required in storage for the binary field. For a two-position binary field, the entry in columns 40-42 is 4; for a four-position binary field, the entry is 9.

*Entries with Decimal Positions*

When the entries of a table are numeric, it is necessary to specify in column 44 the number of decimal positions (0-9) in each entry. Even if a numeric entry contains no decimal positions, a 0 must still be entered to indicate numeric data. When decimal positions are not specified (column 44 left blank, as in Figure 8-5), RPG II considers the table entries to be alphameric.

*Sequence of Table Entries*

For TABITM, the item codes need not be in any particular order. Thus, column 45 is left blank in Figure 8-5. However, if the table entries are in ascending or descending order, an A or a D is entered under Table Sequence (column 45). Note that if a table is to be in sequence the entry is made on the Extension sheet. For input files, other than table files, the sequence entry is always made on the File Description sheet.

**Coding the Table Lookup Operation (LOKUP)**

Once the table input records have been described, you tell RPG II to search the table by coding the LOKUP operation on the Calculations sheet. This involves specifying:

1. The LOKUP operation code.
2. The name of the table to be searched.
3. The data which is being searched for.
4. Conditions which must be satisfied for a successful search.

As shown in Figure 8-7, the operation code LOKUP is entered in columns 28-32 of the Calculations sheet. This operation code causes a search to be made for a particular item in the table named in Factor 2. Thus the name of the table being searched, TABITM, is entered under Factor 2 (columns 33-42), beginning in column 33. Remember that the table being searched must have been previously described on the Extension sheet.

Factor 1 (columns 18-27) contains the field name of the data which is used for comparison during the table search. In this case, the second field of the sales record (called ITMORD) contains the code for the item ordered (the search data). Thus, ITMORD is entered, beginning in column 18.

The fields on each SALES record have been described on the Input sheet. The field (ITMORD) which contains the search data must have been described so that it agrees with the way the table entries have been described. That is, the search data and the table entries must have the same length, the same number of decimal positions, and the same format (alphameric or numeric). As shown in Figure 8-8, both ITMORD and the table entries are defined as three characters long and as alphameric (no decimal positions specified).

In this case, the item which is being searched for must be an exact match of the search data. This is referred to as searching for an *equal* condition only. The lookup procedure would begin at the first element of TABITM and continue, one element at a time, until an equal entry is found. For this reason, it isn't necessary that the table elements be in any particular order when searching for an equal condition.

Of course, if the item searched for is not found after checking all elements of TABITM, the company does not carry that item in stock. Thus, the equal condition must be satisfied if this search is to be successful.

But, how will you know if the search was successful? To determine this, you must know if an equal match was found or not. Thus, you should assign a resulting indicator for the lookup which will turn on if (and when) the equal condition is satisfied.

As shown in Figure 8-7, the indicator 05 is assigned by entering 05 on the Calculation sheet under Lookup Equal (columns 58-59). If an entry cannot be found in the table to correspond to the search data, the 05 indicator will turn off.

## TWO TABLE SEARCH

As you have seen, a single table can be searched merely to see if certain information (an item code) is in the table. However, usually you will want to do more than this. For example, when the orders are shipped, you will also want to send bills to each customer for the amount of the order. Before RPG II can print the bills, it must calculate the amount each customer owes. To do this, the unit cost of each item must be determined. The unit cost of an item is then multiplied by the number ordered to give the total amount due from a customer for that type of item.

**IBM** International Business Machine Corporation

**RPG CALCULATION SPECIFICATIONS**

Form GX21-9093  
Printed in U.S.A.

Program \_\_\_\_\_ Card Electro Number \_\_\_\_\_  
 Programmer \_\_\_\_\_ Date \_\_\_\_\_ Punching Instruction \_\_\_\_\_ Graphic \_\_\_\_\_ Punch \_\_\_\_\_

Page 1 of 2 Program Identification 75 76 77 78 79 80

Line	Form Type	Control Level (L, U, B, C, P, S, R, AN, OR)	Indicators			Factor 1	Operation	Factor 2	Result Field		Resulting Indicators	Comments
			And	And	Not				Name	Length		
0 1	C					ITMORD		LOKUPTABITM			Plus Minus Zero	
0 2	C										Compare	ØSIS ITEM IN STK

Figure 8-7. Specifying a Single-Table Search

**IBM** International Business Machine Corporation

**RPG INPUT SPECIFICATIONS**

Form GX21-9094 U/M 050  
Printed in U.S.A.

Program \_\_\_\_\_ Card Electro Number \_\_\_\_\_  
 Programmer \_\_\_\_\_ Date \_\_\_\_\_ Punching Instruction \_\_\_\_\_ Graphic \_\_\_\_\_ Punch \_\_\_\_\_

Page 1 of 2 Program Identification 75 76 77 78 79 80

Line	Form Type	Filename	Sequence Number (1-N)	Record Identifying Indicator	Record Identification Codes			Field Location		Field Name	Control Level (L, U, B, C, P, S, R, AN, OR)	Matching Fields or Chaining Fields	Field Record Relation	Field Indicators			
					1	2	3	From	To					Plus	Minus	Zero or Blank	
0 1	I	SALES	AA	Ø1													
0 2	I							2	70	CLSTM							
0 3	I							8	10	ITMORD							
0 4	I							11	13	ØTYORD							

Search Word:  
3 Alphameric Characters

Table Entry:  
3 Alphameric Characters

**IBM** International Business Machine Corporation

**RPG EXTENSION AND LINE COUNTER SPECIFICATIONS**

Form X21-9091  
Printed in U.S.A.

Program \_\_\_\_\_ Card Electro Number \_\_\_\_\_  
 Programmer \_\_\_\_\_ Date \_\_\_\_\_ Punching Instruction \_\_\_\_\_ Graphic \_\_\_\_\_ Punch \_\_\_\_\_

Page 1 of 2 Program Identification 75 76 77 78 79 80

Line	Form Type	Record Sequence of the Chaining File		To Filename	Table or Array Name	Number of Entries Per Record	Number of Entries Per Table or Array	Length of Entry	Table or Array Name (Alternating Format)	Length of Entry	Comments
		From Filename	Number of the Chaining Field								
0 1	E				TABITM	32	98	3			ITEM CODES IN STK
0 2	E										

Figure 8-8. Specifying the Same Length for Search Word and Table Entry



At this point, you have already created a table (TABITM) listing the codes of all items the company sells. The unit cost for each item (a 5-digit field on each inventory file record) can be stored in a second table, called TABCST. This table should be organized such that the position of a cost within TABCST corresponds to the position of its related item code in TABITM (Figure 8-9).

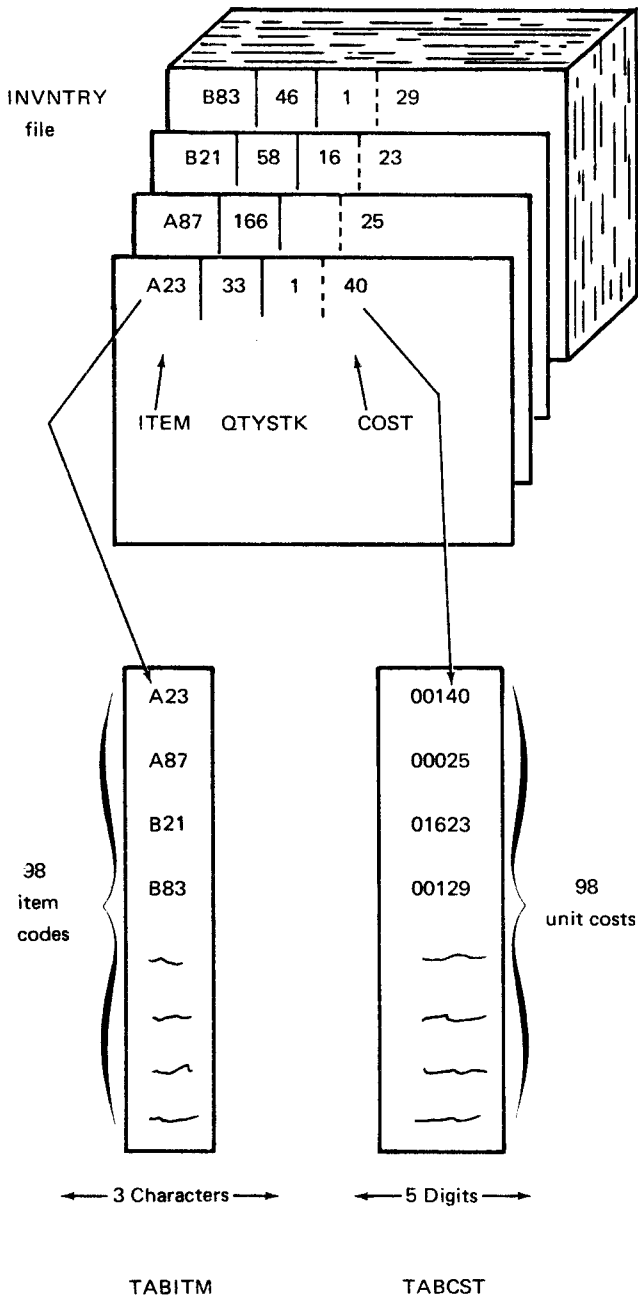

Figure 8-9. Creating Two Related Tables

Let's take a look at one of the records in the SALES file (Figure 8-10) and see how the two tables can be used in determining the appropriate cost for the item ordered. The procedure is much the same as the way you located Ken Adams' telephone number in the telephone directory.

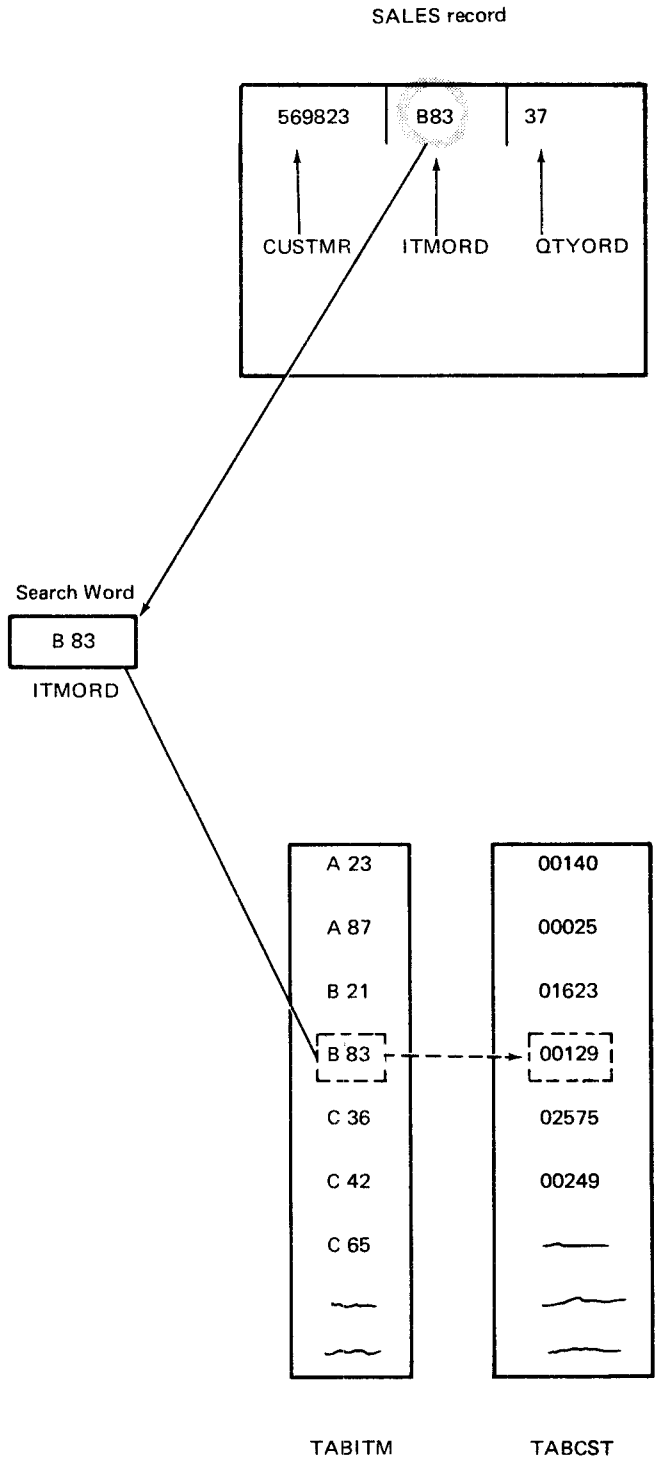

Figure 8-10. Performing a Two-Table Search

First, TABITM is searched to find the table element which contains the same item code as the search word (B83) on the SALES record. If no match is found, that SALES record can be selected into a special stacker so the customers can be notified of the orders which can't be filled. However, in this case, the equal entry is found in the fourth element of TABITM. The entries in TABCST were organized to correspond with entries in TABITM. Therefore, the fourth element of TABCST contains the unit cost for the search word. The program can then use the information referenced (unit cost) to calculate the amount to be billed.

When two related tables are used, as in this example, actually only one table is searched. When the search condition (in this case, an equal match) has been satisfied, the data in the corresponding position or element of the second table (related table) becomes available. Thus, the first table is used as a means of locating data in the second table. In a telephone directory, a person's name is used as a means of locating his telephone number.

### Designing Table Input Records for Two Tables

#### Records With Entries For Only One Table

In designing the table input records for TABITM, you were concerned only with entries for a single table. Thus, four table input records were created to contain only item codes.

Another set of table input records could be created to contain the 98 unit cost entries for TABCST. Each unit cost entry (from the inventory records) requires five columns (three digits for dollars, two digits for cents). Again, it is up to you to determine how many records you wish to use and the number of entries to be contained in each record. For example, let's say that 18 entries (columns 1-90) are punched into each of five table input cards and the remaining eight entries are punched into columns 1-20 of a sixth card.

As shown in Figure 8-11, you would then have two separate table input files: records for TABITM containing only item codes and TABCST records containing only unit cost amounts.

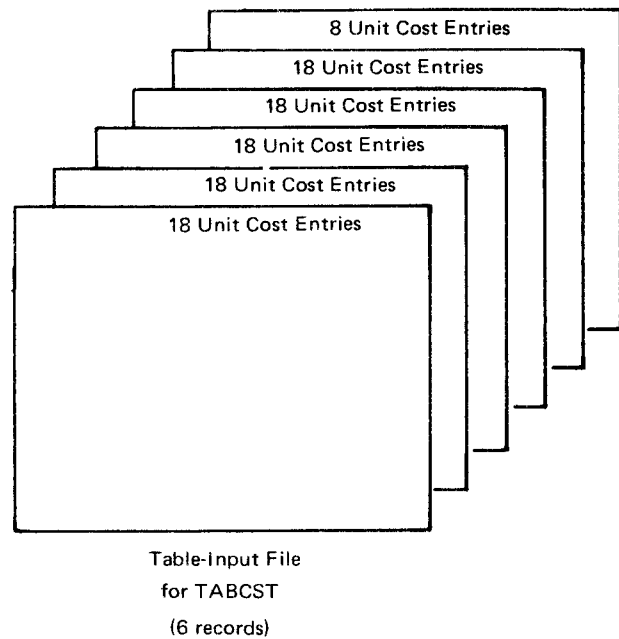
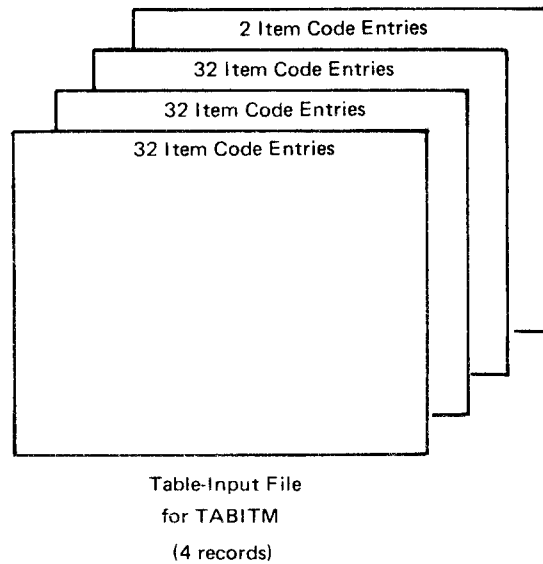

Figure 8-11. Separate Records for Each Table

### Records With Entries For Two Tables

Another method of designing table input records allows you to use only one table input file for both tables. This may save input record space and will usually reduce the number of RPG II specifications needed to describe the table input records. Entries from the first table are alternated with entries from the second table (Figure 8-12). The records are then referred to as alternating format table input records.

As you can see, a table input record can begin (position 1) with an entry from either the first table or the second table. However, if you decide to use the alternating format, every record in the table input file must begin with the same type of table entry (table 1 or table 2).

The number of entries that you put on an alternating format, table input record is still up to you. If you wish, a single record can contain one code for TABITM and one unit cost from TABCST. Or, the record may contain as many pairs of related entries as possible. In this case, all records, except the last, must contain the same number of entries.

For TABITM and TABCST, each pair of related entries will require eight card columns. By punching 12 pairs of entries in a record, an entire card can be filled. Thus a table input file to contain all entries (98 pairs) from both tables can consist of nine alternating format, table input cards. The first eight records might each contain 12 pairs of entries and the last record might contain two pairs of entries.

As mentioned before, entries for TABITM are each 3-character alphameric data. For TABCST, 5-digit numeric entries are needed. All of the entries for a single table must be alike; that is, all alphameric or all numeric. However, the entries for an alphameric table and the entries for a numeric table can both be on the same table input record when an alternating format is used.

Although each table input record contains entries from both tables, actually two separate tables are created in storage from these records. The RPG II Compiler knows that two tables are to be set up, rather than a single table, because of the way the records are described on the Extension sheet.

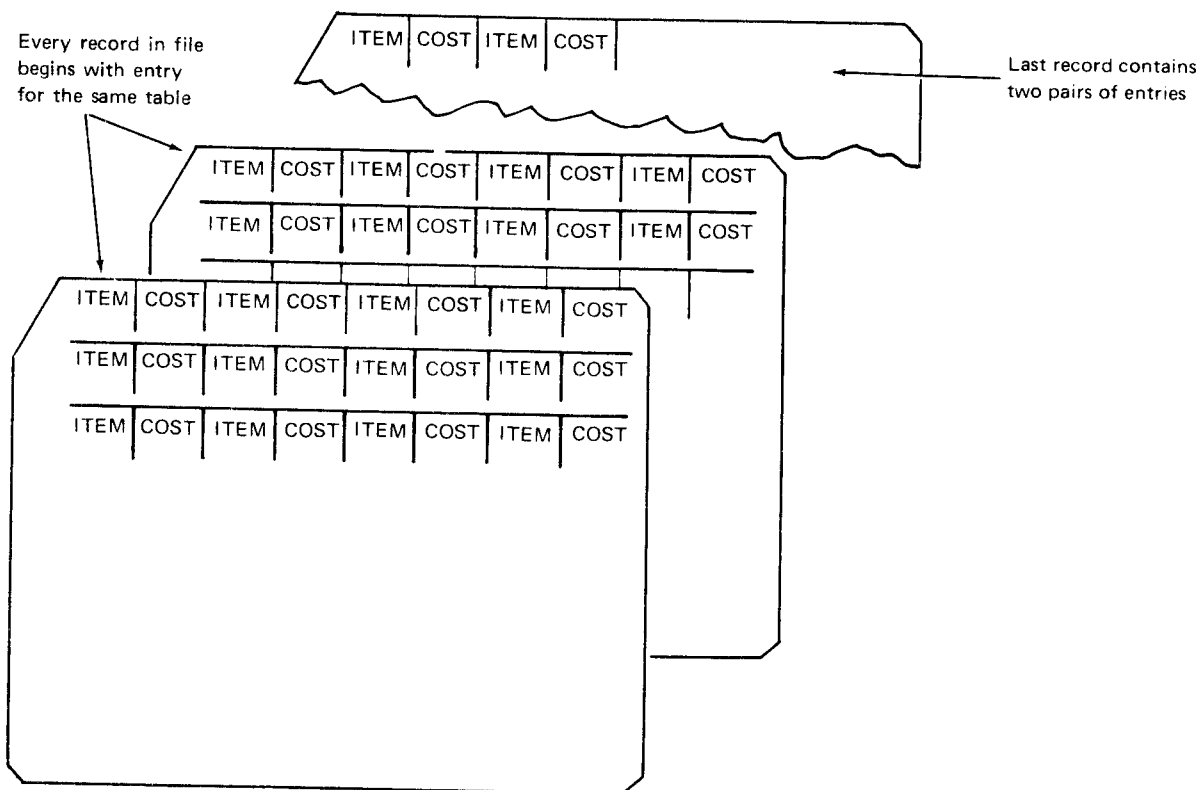

Single Table - Input File.  
Entries for TABITM and  
TABCST in Alternating  
Format.

Figure 8-12. Alternating-Format Table-Input Records

## Describing Two Tables with Extension Specifications

When two related tables are used in a program, you have the choice of designing two table input files (one for each table) or only one table input file consisting of alternating format table input records.

If you decided to set up TABITM and TABCST using separate files, as discussed earlier, the two tables would be described as shown in Figure 8-13. Since each table has its own set of input records, a separate line of extension specifications is needed for each table.

Now take a look at Figure 8-14 which describes the same two tables. Notice that only one extension line is coded when alternating format, table input records are used. Since one line is coded for each set of input records, the second table of the alternating format record must be entered on the same extension line as the first table.

Remember that two separate tables are created, even if you use alternating format records. Therefore, both tables must have unique names, which are specified on the Extension sheet. The table whose entry appears first on a table input record is named in columns 27-32. The name of the alternating table (in this case, TABCST) is entered in columns 46-51 of the same line. The alternating table is always the table whose entry is the second one in a pair of related entries.

Notice that Number of Entries Per Record (columns 33-35) and Number of Entries Per Table or Array (columns 36-39) do not have corresponding specification columns for alternating tables. Since the number of entries per record and

RPG EXTENSION AND LINE COUNTER SPECIFICATION																																																						
Punching Instruction																										Graphic					Card Electro Number																							
Punch																																																						
Extension Specifications																																																						
To Filename	Table or Array Name	Number of Entries Per Record	Number of Entries Per Table or Array	Length of Entry	P/B/L/R	Decimal Positions Sequence (A/D)	Table or Array Name (Alternating Format)	Length of Entry																																														
19 20 21 22 23 24 25 26	27 28 29 30 31 32	33 34 35	36 37 38 39	40 41 42	43	44 45 46	47 48 49 50 51	52 53 54																																														
	TABITM	32	98	3																																																		
	TABCST	18	98	5	2																																																	

Figure 8-13. Describing Separate Table-Input Records

number of entries per table must be the same for each of the alternating tables, separate specifications are not needed for the second table.

However, the Length of Table Entry (columns 52-54) must be indicated since it may be different for the two tables. In Figure 8-14, a 3 has been entered in columns 40-42 as the table entry length for TABITM, while a 5 has been entered in columns 52-54 specifying the length of the unit cost entries for TABCST.

The unit cost entries for TABCST are in the form of 12467, which would represent \$124.67. Therefore, a 2 has been entered for the number of decimal positions (column 56). This specification indicates that the entry is numeric and contains two decimal positions.

RPG EXTENSION AND LINE COUNTER SPECIFICATIONS																																																						
IBM International Business Machine Corporation																										Form X21-9091 Printed in U.S.A.																												
Program																										Punching Instruction					Graphic					Card Electro Number																		
Programmer																										Date					Punch																							
																																				Page 1 of 2					Program Identification 75 76 77 78 79 80													
Extension Specifications																																																						
Line	Form Type	Record Sequence of the Chaining File	To Filename	Table or Array Name	Number of Entries Per Record	Number of Entries Per Table or Array	Length of Entry	P/B/L/R	Decimal Positions Sequence (A/D)	Table or Array Name (Alternating Format)	Length of Entry	P/B/L/R	Decimal Positions Sequence (A/D)	Comments																																								
3 4 5 6	7 8 9 10 11 12 13 14 15 16 17 18	19 20 21 22 23 24 25 26	27 28 29 30 31 32	33 34 35	36 37 38 39	40 41 42	43	44 45 46	47 48 49 50 51	52 53 54	55	56 57 58 59 60 61 62 63 64 65 66 67 68 69 70 71 72 73 74																																										
0 1	E			TABITM	12	98	3			TABCST	5	2																																										
0 2	E																																																					

Figure 8-14. Describing Alternating-Format Table-Input Records

The table entries for TABCST are not in any special alphabetic or numeric order which the RPG II Compiler program could check for accuracy. Thus, no table sequence is specified for TABCST (column 57 is left blank). Likewise, telephone numbers in a directory are not in sequence. However, just as phone numbers are arranged to correspond with related names, the TABCST entries have been arranged so a particular unit cost corresponds with its related item code.

### Coding the Table Lookup Operation (LOKUP)

Now that both tables have been set up, TABITM is to be searched to find the table element which contains the same item code as the code (search word) on the SALES record. This simple lookup procedure is coded with the same calculation specifications as you used before (Figure 8-15). The field name or literal constant which contains the search code is entered under Factor 1 (ITMORD), the LOKUP operation is specified in columns 28-32, and the name of the table being searched (TABITM) is entered under Factor 2. If an equal match is found in searching the table, resulting indicator 05 will be turned on, as specified in columns 58-59.

However, you want to do more than just see if the item ordered is carried in stock. If the search is successful, you also want to determine the appropriate unit cost for the ordered item.

To reference the second table (TABCST), additional specifications must be entered on the same line of the Calculation sheet. As Figure 8-15 shows, the name of the table (TABCST) from which you wish data to be made available is entered as the Result Field (columns 43-48). If (and when) the equal search is satisfied, the corresponding data *looked-up* in TABCST will be made available.

Field length and decimal positions have not been entered in columns 49-52. These specifications are not required since the table named under Result Field (TABCST) was previously described on the Extension sheet. However, if you want to enter these specifications again on the Calculation sheet, the numbers must agree with those in the extension specifications. For TABCST, field length must be 5 (in column 51), the length defined for a TABCST entry, and the number of decimal positions must be 2 to agree with the Extension sheet.

### USING TABLE DATA IN CALCULATIONS AND OUTPUT

You perform a table lookup because you want the information referenced to be used in some way. In some programs, you may wish to use the data in a calculation. At other times, you merely want the data to be used for output.

### Conditioning Operations on the Basis of a Table Lookup

In the sales job, the specifications for a LOKUP operation instructed the program to search TABITM for an entry equal to an item in a SALES record and then make available the appropriate unit cost entry from a second table. If the search was successful, resulting indicator 05 would have been turned on.

Providing the item code is carried in stock (successful search), you want to use its unit cost to determine the amount the customer owes for the number of items ordered. In other words, the calculation specification in line 02 of Figure 8-16 should be performed.

Line		Form Type	Control Level (L, LP, SF, AN/OR)	And	And	Factor 1	Operation	Factor 2	Result Field		Resulting Indicators			Comments	
3	4	5	6	7	8	9	10	11	12	13	14	15	16		17
18	19	20	21	22	23	24	25	26	27	28	29	30	31		32
33	34	35	36	37	38	39	40	41	42	43	44	45	46		47
0 1	C					ITMORD	LOKUP	TABITM	TABCST						
0 2	C													05GET COST OF ITM	

Figure 8-15. Specifying a Two-Table Search

RPG CALCULATION SPECIFICATIONS																																																												Form GX21-9093
IBM International Business Machine Corporation																																																												Printed in U.S.A.
Program																				Punching Instruction					Graphic					Card Electro Number										Page 1 2 of		Program Identification 75 76 77 78 79 80																		
Programmer																				Date					Punch																																			

C	Line	Form Type	Control Level (LO, Lg, LR, SR, AN/OR)	Indicators												Factor 1	Operation	Factor 2	Result Field			Resulting Indicators			Comments
				And						And									Name	Length	Decimal Positions	Plus	Minus	Zero	
0	1	C		Ø1										ITMORD		LOKUPTABITM		TABCST							Ø5GET COST OF ITM
0	2	C		Ø5	Ø1									TABCST		MULT QTYORD		AMOUNT		62					AMOUNT DUE
0	3	C																							

Figure 8-16. Performing Calculations Only After a Successful Search

However, if the item code was not found, indicator 05 would have been turned off and no cost entry would be available for the item ordered. For the example given, you could have the SALES record for the current lookup selected into a separate stacker. In this way, you can identify which customers must be notified that their orders cannot be filled.

**Note:** In order to select a stacker for input records on the basis of a calculation operation (for example, LOKUP), the file must be defined as a *combined* file on the File Description sheet and the stacker must be specified on the Output-Format sheet. See the chapter entitled *Card Output Operations* for a discussion of stacker selection.

Ordinarily, all calculation specifications are performed before any output is done. But if the search for an item was unsuccessful, you would be unable to calculate a bill for the customer correctly.

Therefore, there must be a way to bypass the calculations if the lookup is unsuccessful. This is done by entering 05 as a conditioning indicator in columns 10-11 (see Figure 8-16). The calculation operations will be done only when 05 is on. In this way, the same resulting indicator used to determine the results of the lookup becomes a conditioning indicator to determine if a calculation operation should be performed.

If the item is not carried in stock (05 off), any calculations conditioned by 05 are not performed. The program then performs the output specifications since there are no more calculations to be done. (See Figure 8-17.) For this example, a card is selected into a different stacker only when the search is unsuccessful, not for every item ordered. Thus, the output specification is conditioned by entering **N05** (05 *not* on) and the record identifying indicator in columns 23-28.

RPG OUTPUT SPECIFICATIONS																																																												Form GX21-9090 U/M 050*
IBM International Business Machine Corporation																																																												Printed in U.S.A.
P P																				Punching Instruction					Graphic					Card Electro Number										Page 1 2 of		Program Identification 75 76 77 78 79 80																		
In order to specify stacker selection based on the results of a calculation operation (N05), SALES must be defined as a combined file.																				Punch																																								
Line	Form Type	Filename	Type It	Stacker	Editor	Printer	Before	After	Output Indicators												Field Name	Edit Codes	End Position in Output Record	P/B/L/R	Constant or Edit Word																																			
									And						And										Commas	Zero Balances to Print	No Sign	CR	-	X																														
0	1	O																								Yes	Yes	1	A	J	X = Remove Plus Sign																													
0	2	O	SALES													*AUTO									Yes	No	2	B	K	Y = Date																														
																									No	Yes	3	C	L	Z = Zero																														
																									No	No	4	D	M	Z = Zero Suppress																														

Figure 8-17. Performing Output Only if Search Was Unsuccessful

At this point, then, you know that you may or may not want certain calculations and output specifications performed, depending on the results of a table lookup. This is accomplished by using conditioning indicators.

**Referencing Data Following a Successful Search**

According to the RPG II program cycle, input specifications are performed first, followed by calculations and then output. Thus, after reading a data record, all calculations for that record and then all output operations for that record are performed, before the next data record is read and processed.

With this logic in mind, let's take a look at the output wanted from the table lookup program just discussed. TABITM contains the codes of all items carried in stock. The related table, TABCST, contains the unit cost for each item. A SALES file contains the records of customer orders, providing the customer number, code for the item ordered, and the quantity ordered.

The purpose of the program is to calculate the amount each customer owes and print the information on a report. The report is to contain more than just the total amount due, however. As shown in Figure 8-18, each order should have a line printed with data from the SALES record (item ordered, quantity ordered), data looked up from TABCST (unit cost), and data from calculations (total amount due).

After the first SALES record is read into the computer, Figure 8-19 shows that TABITM is searched to find an entry equal to the item code on that SALES record (ITMORD). If a successful search is made, indicator 05 is turned on and the table entry looked up is available for use in further calculations or output operations. In this program, you want to multiply the *looked-up* cost by the number of items the customer ordered (field QTYORD on the SALES record).

REPORT				
QUANTITY	ITEM		UNIT COST	TOTAL
_____	_____		_____	_____
_____	_____		_____	_____
_____	_____		_____	_____
_____	_____		_____	_____

Figure 8-18. Output from a Table Lookup

What is the name of the field containing the cost? The specifications in line 02 of Figure 8-19 shows this instruction. The name of the table (TABCST) which provided the cost has been entered under Factor 1. Whenever a table name is used as a factor in any operation other than a LOKUP (in this case, the operation MULT), the name refers to the data item made available by a LOKUP. Thus, TABCST in line 02 refers to the unit cost of the item just looked up.

Since the table name, TABCST, is used only as a factor and not as the result field of the MULT operation (line 02), the contents of the TABCST data item are not changed. It still contains the unit cost for the item on the sales record.

Once all calculations have been performed, the RPG II program performs the output specifications (Figure 8-20) for this same SALES record. The specifications in line 01 are not performed, since the SALES record is selected into stacker 3 only if the search is unsuccessful (indicator 05 off). However, the rest of the output specifications are performed. Suppose the REPORT file is defined on the File

IBM		RPG CALCULATION SPECIFICATIONS		Form GX21-9093 Printed in U.S.A.											
Program	Programmer	Date	Punching Instruction	Graphic Punch	Card Electro Number										
Page 1 of 2		Program Identification		75 76 77 78 79 80											
Line	Form Type Control Level (L, D, L, R, SR, AN, OR)	Indicators						Factor 1	Operation	Factor 2	Result Field		Resulting Indicators		Comments
		And	And	Not	Not	Not	Not				Name	Length	Plus	Minus	
01	C	01					ITMORD	LOKUP	TABITM	TABCST		05			
02	C	05	01				TABCST	MULT	QTYORD	AMOUNT	62				
03	C														

Figure 8-19. Referencing Looked-up Table Data

**RPG OUTPUT SPECIFICATIONS**

GX21 9090 U/M 050\*  
Printed in U.S.A.

Program	Date	Punching Instruction	Graphic	Card Electro Number
Programmer			Punch	

Page 1 of 2 Program Identification 75 76 77 78 79 80

Line	Form Type	Filename	Type (H/D/A/E)	Space	Skip	Output Indicators						Field Name	Edit Codes			End Position in Output Record
						Before	After	Not	Not	Not	Not		B/A/C	D/S/R	P/B/L/R	
01	O	SALES	D3									*AUTO				
02	O	REPORT	D	1							N05	01				
03	O															
04	O											CUSTMR		6		
05	O											ITMORD		12		
06	O											QTYORD		18		
07	O											TABCST3		30		
08	O											AMOUNT3		57		

**Figure 8-20. Output of Data Looked-up in a Table Search**

Description sheet as a printer output file. Lines 02-05 cause the data from the SALES record to be printed on the report. By referencing the name of the table looked up (TABCST) in line 06, the program prints the data contained in the table element, the unit cost for this first SALES record. Line 07 then tells the program to print the amount due, which was previously calculated.

Once all output has been performed for the first record, the RPG II cycle causes the input specifications to be performed again. Thus, the next SALES record is read in, and a table

LOKUP is performed for the second record. On a successful search, the unit cost for the second SALES record is made available. The cost for the second item can then be used in calculations and output specifications by referring to the name of the table looked up.

Each table LOKUP operation performed searches for only one entry from a table. This data is then available to be used in calculations and output specifications for that record. The data available does not change until the next table lookup is performed for that table.



TABAMT TABTAX		TABAMT TABTAX		TABAMT TABTAX		TABAMT TABTAX		TABAMT TABTAX		TABAMT TABTAX	
.16	.00	16.83	.50	33.49	1.00	50.16	1.50	66.83	2.00	83.49	2.50
.49	.01	17.16	.51	33.83	1.01	50.49	1.51	67.16	2.01	83.83	2.51
.83	.02	17.49	.52	34.16	1.02	50.83	1.52	67.49	2.02	84.16	2.52
1.16	.03	17.83	.53	34.49	1.03	51.16	1.53	67.83	2.03	84.49	2.53
1.49	.04	18.16	.54	34.83	1.04	51.49	1.54	68.16	2.04	84.83	2.54
1.83	.05	18.49	.55	35.16	1.05	51.83	1.55	68.49	2.05	85.16	2.55
2.16	.06	18.83	.56	35.49	1.06	52.16	1.56	68.83	2.06	85.49	2.56
2.49	.07	19.16	.57	35.83	1.07	52.49	1.57	69.16	2.07	86.83	2.57
2.83	.08	19.49	.58	36.16	1.08	52.83	1.58	69.49	2.08	87.16	2.58
3.16	.09	19.83	.59	36.49	1.09	53.16	1.59	69.83	2.09	87.49	2.59
3.49	.10	20.16	.60	36.83	1.10	53.49	1.60	70.16	2.10	87.83	2.60
3.83	.11	20.49	.61	37.16	1.11	53.83	1.61	70.49	2.11	88.16	2.61
4.16	.12	20.83	.62	37.49	1.12	54.16	1.62	70.83	2.12	88.49	2.62
4.49	.13	21.16	.63	37.83	1.13	54.49	1.63	71.16	2.13	88.83	2.63
4.83	.14	21.49	.64	38.16	1.14	54.83	1.64	71.49	2.14	89.16	2.64
5.16	.15	21.83	.65	38.49	1.15	55.16	1.65	71.83	2.15	89.49	2.65
5.49	.16	22.16	.66	38.83	1.16	55.49	1.66	72.16	2.16	89.83	2.66
5.83	.17	22.49	.67	39.16	1.17	55.83	1.67	72.49	2.17	90.16	2.67
6.16	.18	22.83	.68	39.49	1.18	56.16	1.68	72.83	2.18	90.49	2.68
6.49	.19	23.16	.69	39.83	1.19	56.49	1.69	73.16	2.19	90.83	2.69
6.83	.20	23.49	.70	40.16	1.20	56.83	1.70	73.49	2.20	91.16	2.70
7.16	.21	23.83	.71	40.49	1.21	57.16	1.71	73.83	2.21	91.49	2.71
7.49	.22	24.16	.72	40.83	1.22	57.49	1.72	74.16	2.22	91.83	2.72
7.83	.23	24.49	.73	41.16	1.23	57.83	1.73	74.49	2.23	92.16	2.73
8.16	.24	24.83	.74	41.49	1.24	58.16	1.74	74.83	2.24	92.49	2.74
8.49	.25	25.16	.75	41.83	1.25	58.49	1.75	75.16	2.25	92.83	2.75
8.83	.26	25.49	.76	42.16	1.26	58.83	1.76	75.49	2.26	93.16	2.76
9.16	.27	25.83	.77	42.49	1.27	59.16	1.77	75.83	2.27	93.49	2.77
9.49	.28	26.16	.78	42.83	1.28	59.49	1.78	76.16	2.28	93.83	2.78
9.83	.29	26.49	.79	43.16	1.29	59.83	1.79	76.49	2.29	94.16	2.79
10.16	.30	26.83	.80	43.49	1.30	60.16	1.80	76.83	2.30	94.49	2.80
10.49	.31	27.16	.81	43.83	1.31	60.49	1.81	77.16	2.31	94.83	2.81
10.83	.32	27.49	.82	44.16	1.32	60.83	1.82	77.49	2.32	95.16	2.82
11.16	.33	27.83	.83	44.49	1.33	61.16	1.83	77.83	2.33	95.49	2.83
11.49	.34	28.16	.84	44.83	1.34	61.49	1.84	78.16	2.34	94.83	2.84
11.83	.35	28.49	.85	45.16	1.35	61.83	1.85	78.49	2.35	95.16	2.85
12.16	.36	28.83	.86	45.49	1.36	62.16	1.86	78.83	2.36	95.49	2.86
12.49	.37	29.16	.87	45.83	1.37	62.49	1.87	79.16	2.37	95.83	2.87
12.83	.38	29.49	.88	46.16	1.38	62.83	1.88	79.49	2.38	96.16	2.88
13.16	.39	29.83	.89	46.49	1.39	63.16	1.89	79.83	2.39	96.49	2.89
13.49	.40	30.16	.90	46.83	1.40	63.49	1.90	80.16	2.40	96.83	2.90
13.83	.41	30.49	.91	47.16	1.41	63.83	1.91	80.49	2.41	97.16	2.91
14.16	.42	30.83	.92	47.49	1.42	64.16	1.92	80.83	2.42	97.49	2.92
14.49	.43	31.16	.93	47.83	1.43	64.49	1.93	81.16	2.43	97.83	2.93
14.83	.44	31.49	.94	48.16	1.44	64.83	1.94	81.49	2.44	98.16	2.94
15.16	.45	31.83	.95	48.49	1.45	65.16	1.95	81.83	2.45	98.49	2.95
15.49	.46	32.16	.96	48.83	1.46	65.49	1.96	82.16	2.46	98.83	2.96
15.83	.47	32.49	.97	49.16	1.47	65.83	1.97	82.49	2.47	99.16	2.97
16.16	.48	32.83	.98	49.49	1.48	66.16	1.98	82.83	2.48	99.49	2.98
16.49	.49	33.16	.99	49.83	1.49	66.49	1.99	83.16	2.49	99.83	2.99
										100.16	3.00

Figure 8-21. Two Related Tables for Determining Sales Tax



Since customer orders can be any amount, the table lookup must be coded to handle all possibilities. For some orders, an equal match can be found in TABAMT; for others, the table entry will be higher than the search word. Therefore, the same resulting indicator (23) should be assigned to turn on if either a high or equal condition is satisfied (see columns 54-55 and 58-59 of Figure 8-23).

A table can also be searched to locate an entry which is lower in value than the search word. In such a case, the table is searched for the entry which is lower (less) than, yet closest in value to, the search word. Searching for a low condition is specified the same way as searching for a high condition, except the resulting indicator is entered in columns 56-57, rather than 54-55.

In coding a table lookup, either one or two conditions may be specified. A particular search may be successful by satisfying:

1. An equal condition only.
2. A high condition only.
3. A low condition only.
4. Either a high or equal condition.
5. Either a low or equal condition.

Searching for either a low or high condition (for the same LOKUP operation) would not be specified, since a majority of items in the table will satisfy one of the two conditions. The condition(s) which must be satisfied can depend on the type of data in the table, the data used as the search word, and the sequence of the data within the table.

### Sequence of Tables

To perform a table search for an equal condition only, it isn't necessary that table entries be in any particular order. Starting at the beginning of the table, the table elements are checked, one at a time, until an equal entry is found or the end of the table is reached, whichever occurs first.

However, when searching for high or low conditions, table entries must be in either ascending or descending sequence. This is because the program must select the entry which is higher or lower than, yet closest in value to, the search word. With the table entries in sequence, the program can determine where in the sequence the search word value would appear if it were in the table. For example, if table elements 2-4-6-9-11 are in ascending sequence, a search word of 7 would naturally come between elements 6 and 9. Thus, element 6 would satisfy the low condition, while element 9 would satisfy the high condition (closest in value and yet higher than the search word).

Likewise, if the table is in descending sequence 11-9-6-4-2, the search word (7) would come between 9 and the 6. Regardless of the sequence (A or D), 9 would satisfy the high condition, while 6 would satisfy the low condition.

If the table elements are not in sequence, as 2-4-11-9-6, the LOKUP might retrieve the wrong element. The elements are checked one at a time from the beginning of the table. Therefore, the computer would determine that a search word of 7 would come between the 4 and the 11. A search for a low condition would incorrectly retrieve element 4, because the next element (11) is greater than the search word (7). While the last element (6) is actually closer in value to the search word, it would not be made available. Likewise, a search for a high condition would retrieve

IBM		International Business Machine Corporation		RPG CALCULATION SPECIFICATIONS																				Form GX21-9093 Printed in U.S.A.	
Program				Punching Instruction				Graphic				Card Electro Number				Page 1 2 of		Program Identification 75 76 77 78 79 80							
Programmer				Date				Punch																	
Line	Form Type	Control Level (L0-L9, LR, SR, AN/DR)	Indicators			Factor 1	Operation	Factor 2	Result Field		Resulting Indicators			Comments											
			And	And	Not				Name	Length	Arithmetic	Plus	Minus		Zero										
			Not	Not	Not						1 > 2	1 < 2	1 = 2												
											High	Low	Equal												
0 1	C					ORDAMT		LOKUPTABAMT	TABTAX			23	23												
0 2	C																								

Figure 8-23. Searching for High or Equal Condition







If you know beforehand that the size of your table will increase, you can initially build a short table. In a short table only some of the table entries contain actual table data. The program fills the unused entries with blanks. Thus, TABEMP and TABWAG can be defined as 100 entries each; although for now, you plan to use only 46 entries in each table (see Figure 8-28). Of course, be aware that enough storage will be reserved for 100 entries. The storage required for the unused table entries will not be available to hold any other data.

As new employees are hired, the new table entries can be added by inserting additional table input records. The original extension specifications still correctly describe the table, as they merely indicate the maximum number of entries allowed for each table.

Whether the RPG II source program and the table input records must be recompiled depends on which method was selected originally for loading the table. The methods of loading tables and their effect on short tables is discussed in a following section.

IBM		RPG EXTENSION AND LINE COUNTER SPECIFICATIONS										Form X21-9091 Printed in U.S.A.			
Program		Punching Instruction		Graphic		Card Electro Number						Page 1 2 of		Program Identification 75 76 77 78 79 80	
Programmer		Date		Punch											
Extension Specifications															
Line	Form Type	Record Sequence of the Chaining File		To Filename	Table or Array Name	Number of Entries Per Record	Number of Entries Per Table or Array	Length of Entry	Decimal Positions Sequence (ADD)	Table or Array Name (Alternating Format)	Length of Entry	P/B/L/R	Occurs Positions Sequence (AO)	Comments	
		From Filename	Number of the Chaining Field												
0 1	E				TABEMP	1	100	6		TABWAG	3			2 ASHORT TABLES	
0 2	E														

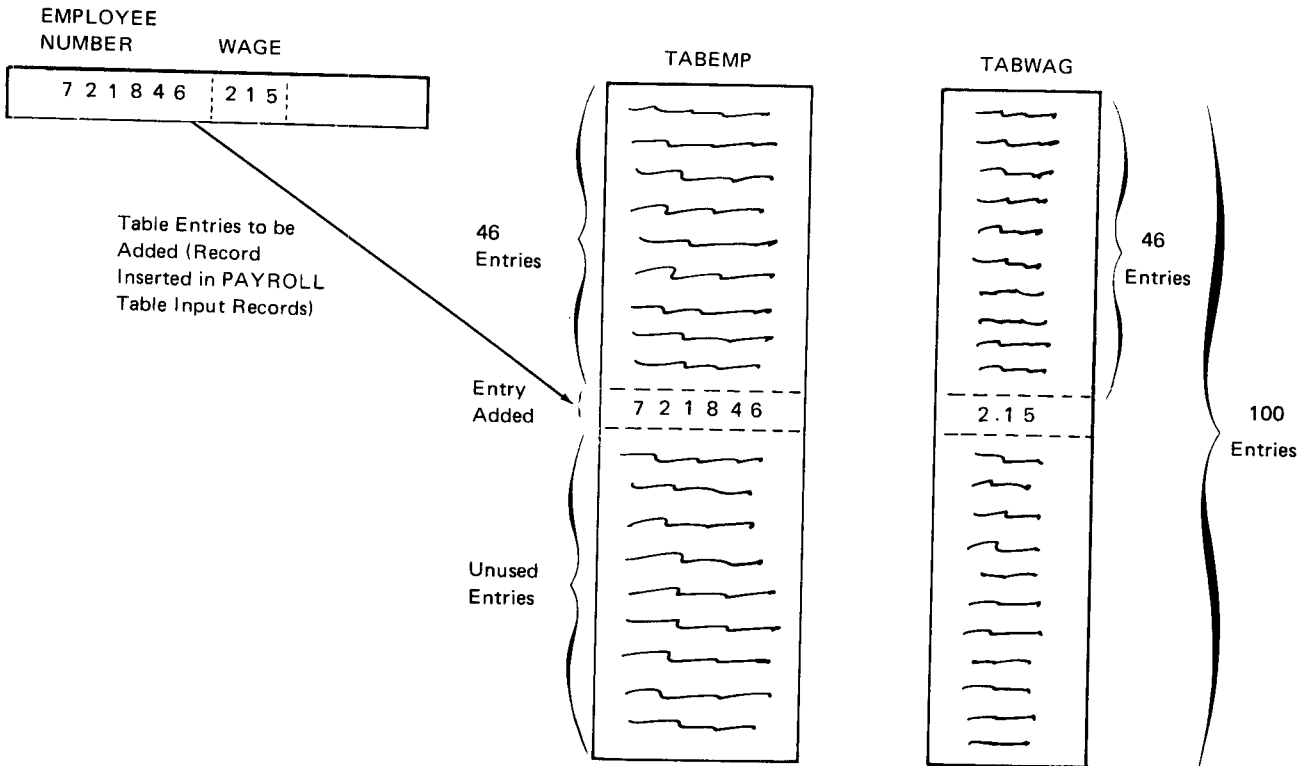

Figure 8-28. Adding Entries to a Short Table

## LOADING TABLES

Table data can be loaded into the computer at two different points: at the time your RPG II source program is compiled (compile time tables) or at the beginning of your RPG II object program execution (pre-execution time tables. How often you wish to make permanent changes to the data contained in the table usually dictates the time at which you choose to load that table. The choice should be made as you plan your application, since your decision may affect the design of your table input records and the specification entries required. Furthermore, loading of the table input records differs, according to the type of table used.

### Compile Time Tables

Tables loaded at the same time as your RPG II source program are referred to as compile time tables. In other words, the table file is compiled (or translated into the machine or object language) along with the RPG II source program. In this way, the table data is actually a part of the object program. Every time you run the particular object program, then, the table(s) are brought into storage at the same time as the program. As you can see, one definite advantage in creating compile time tables is that you avoid the necessity of loading separate table files into the computer every time you wish to run that object program.

### Changing Compile Time Tables

Temporary changes to data in a compile time table exist only for a particular run and are made as easily as for any table. Calculation specifications which have been previously coded in the program can modify any of the table elements.

Making permanent changes to a compile time table or adding new entries to a short compile time table requires recompiling the entire RPG II source program along with the new or changed table input records. The object program produced then contains the current table data. Of course, this process of recompilation requires extra time.

### Loading Compile Time Tables

A table to be compiled with your program should follow the RPG II source program (Figure 8-29). There should be a record immediately before the table containing \*\* in positions 1 and 2. Position 3 must be blank but remaining positions may be used for comments, such as the table name. If more than one table is to be compiled, an \*\* record should be placed before each table. Furthermore, the compile time

tables must be loaded in the same order as they are described on the Extension sheet. The end of file record (/ \* in positions 1-2) which usually comes at the end of the source program is then placed after the last compile time table.

Model 10 Disk System, Model 6, and Model 15 users may place compile time tables in the source library following the source program. The same record sequence as shown in Figure 8-29 is used. See the applicable reference manuals for your system for specific procedures.

### Pre-execution Time Tables

In general, if a table is to be permanently modified often, it is better to create a pre-execution time table. Such a table file is not compiled with your RPG II source program. Instead, only the source program is compiled or translated into the object program. Once the object program has been loaded into the computer to be executed, the table file is loaded separately. Like any other input data file, the table file is then used by the object program, rather than being a part of the program.

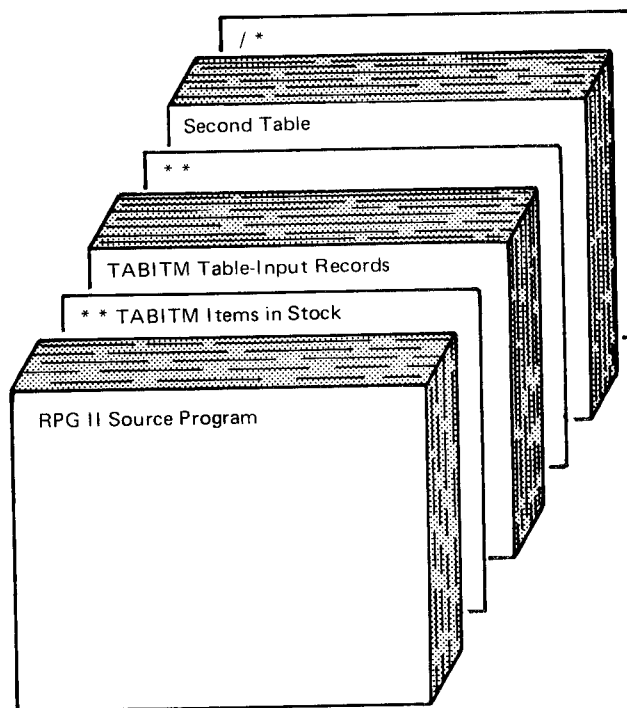

*Card System Users:* The source program and table input records as shown here are placed in the secondary MFCU hopper. The RPG II compiler program is placed in the primary hopper.

Figure 8-29. Loading Compile Time Tables



## Changing a Pre-execution Time Table

Modifying a pre-execution time table takes much less time and effort than changing a compile time table. Modifying the contents of the table permanently (whether a short table or a full table) can be done by inserting and deleting change records. In any event, only the table file is changed. Since there is no need to make changes in the RPG II object program, it isn't necessary to recompile the entire program.

## Loading Pre-execution Time Tables

Pre-execution time tables are similar to any other input data files in that the RPG II object program uses the files when the program is executed. However, unlike other data files, pre-execution time tables are read completely before operations involving the tables are done. An end of file record (/\*) must follow every pre-execution time table file, regardless of whether the table is short or full (Figure 8-30). The \*\* record that precedes each compile time table is not used for pre-execution time tables.

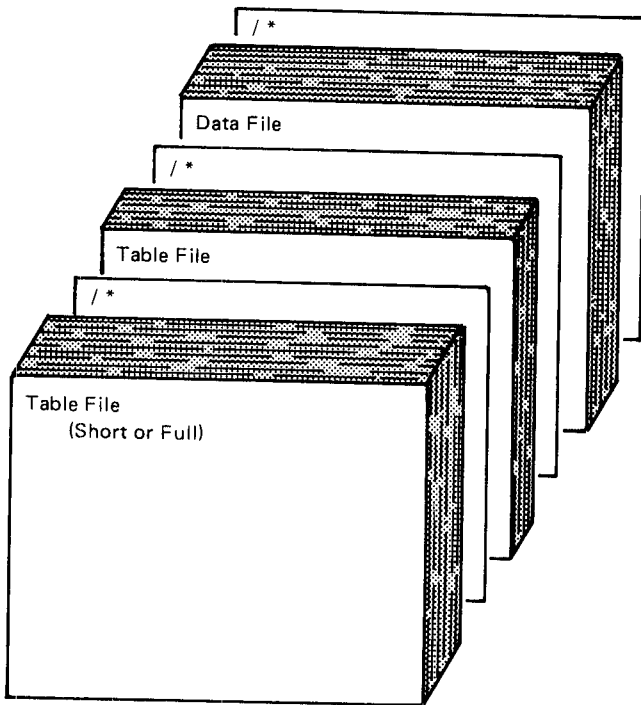

**Model 10 Card System Users:** The table files are loaded from the secondary MFCU hopper. The RPG II object program is loaded from the primary hopper.

**Other Systems:** Table files loaded at pre-execution time may be loaded from console, cards, disk, or tape.

The table files should be in the same order as for compile time tables. All table files are to be loaded in the same order as they are described on the Extension sheet. Furthermore, if both pre-execution time table files and other input data files are to be used by a program, all tables must be loaded before the data files.

## Specifications for Pre-execution Time Tables

Since a pre-execution time table is a separate file to be used by the program, the entire file of table input records must be defined on the File Description sheet, just as any other file must be. This specification sheet is not required for compile time tables because the records are not used as a file. Instead compile time table data becomes a part of the object program.

Figure 8-31 shows the file description specifications required to define a pre-execution time table input file. A filename, different than the table name, should be assigned to the entire table file (columns 7-14). In this case, the file called SALESTAX contains data for both TABAMT and TABTAX. An / in column 15 distinguishes that SALESTAX is an input file. Notice, also that the File Designation entry (column 16) must be a T, to indicate that this is a table file, as well. The Device entry (columns 40-46) indicates the device from which the table file is read; in this example, we are using MFCU2.

Ordinarily, if an input file is to be in a particular sequence, an entry (A or D) is made in column 18 of the File Description sheet. However, when specifying a sequence for table files, the sequence columns (45 and 57) on the Extension sheet must be used, rather than the sequence column on the File Description sheet. An E has been entered in column 39 of the File Description sheet to indicate that the records in this table file are further described on the Extension sheet.

Looking at Figure 8-31, you can see that the filename assigned on the File Description sheet is also entered under From Filename (columns 11-18) of the Extension sheet. This common entry tells the computer that the extension specifications describing TABAMT and TABTAX tables are associated with the SALESTAX file defined on the File Description sheet. For compile time tables, no entry is made in columns 11-18. This is because no file description specifications are made and, thus, no filename is assigned to compile time table records.

**Figure 8-30. Arrangement of Input for Pre-execution Time Tables**

File Description Specification

Line	Form Type	Filename	File Type		Mode of Processing		Device	Symbolic Device	Name of Label Exit	Extent Exit for DAM	File Addition/Unordered	
			File Designation	Sequence	Length of Key Field or of Record Address Field	Record Address Type					Number of Tracks for Cylinder Overflow	Number of Extents
0 2	F	SALESTAXIT	10/U/C/D	A/D	L/R	AP/I/K	EMFCUR				2	63
0 3	F											
0 4	F											
0 5	F											
0 6	F											

Annotations:

- File name differs from table name(s)
- No entry made in column 18 - sequence of table files specified on Extension sheet
- E in column 39 indicates Extension specifications are used.
- Other devices can be used, depending on the system and configuration.

**IBM** International Business Machines Corporation  
 Form X21 9001 Printed in U.S.A.

**RPG EXTENSION AND LINE COUNTER SPECIFICATIONS**

Program: \_\_\_\_\_ Card Electro Number: \_\_\_\_\_  
 Programmer: \_\_\_\_\_ Date: \_\_\_\_\_  
 Page 1 of 2 Program Identification: \_\_\_\_\_

**Extension Specifications**

Line	Form Type	From Filename	To Filename	Table or Array Name	Number of Entries Per Record	Number of Entries Per Table or Array	Length of Entry	Table or Array Name (Alternating Format)	Length of Entry	Comments
0 1	E	SALESTAX		TABAMT	1	301	5	RATABTAX	3	RASALESTAX FILE
0 2	E									
0 3	E									

Annotation: Information which relates this specification to a particular File Description specification.

Figure 8-31. Defining a Pre-execution Time Table File

## OUTPUT OF AN ENTIRE TABLE

Up to now, we have discussed how to write or punch only individual table entries, one at a time. In this way, only table entries which satisfy a search condition (which have been placed in the hold area) have been used as output.

For various reasons, you may want an entire table written or punched out. Perhaps you want a listing of the table entries to determine if any changes should be made. If your program updates a table, you may wish to output all the entries to be used as table input the next time the program is run.

An entire table can be written or punched out only at the end of the job; that is, after all other output has been completed (LR on). Even if the table is a short table, all entries are put out including those which are unused (blanks or zeros).

Writing or punching an entire table at end of job is very easy to specify. Just as for any type of output, the output file must be given a name and assigned to an output device on the File Description sheet. However, no output specifications are necessary for end of job table output. You merely specify the name of the output file in columns 19-26 of the Extension sheets on the same line as you described the table input records. With the extension specifications shown in Figure 8-32, the table will be put out automatically at end of job.

The output data may not be exactly the same as the input data, because table entries are put out as they are at end of job. Thus, if your program has changed or updated any table entries, the modified data will be put out, not the original data. Except for printer output, however, the format of the table output records will be the same as the input records.

IBM		RPG EXTENSION AND LINE COUNTER SPECIFICATIONS		Form X71 9091 Printed in U.S.A.		
Program		Punching Instruction		Card Electro Number		
Programmer		Date		Page 1 2 of Program Identification 75 76 77 78 79 80		
Extension Specifications						
Line	Form Type	Record Sequence of the Chaining File	To Filename	Table or Array Name	Number of Entries Per Record	Number of Entries Per Table or Array
0 1	E	From Filename	LISTING	TABITM 32	98	3
0 2	E					
0 3	E					
0 4	E					
0 5	E					
Comments: ITM CODES IN STK						
File Description Specification						
Line	Form Type	Filename	File Type	Mode of Processing	Device	Symbolic Device
0 2	F	LISTING O	L32		PRINTER	
0 3	F					
0 4	F					
0 5	F					
0 6	F					

Figure 8-32. Specifications for Output of Entire Table at End of Job

(Answers to review questions follow the review.)

1.
  - a. Design the table input records for an inventory table of item numbers. Each item number is a five-digit number. There are 123 unique items in stock. Use either one record per item or one record for a number of items. State the maximum number of records necessary to contain the table data. State the minimum number of records necessary to contain the table data.
  - b. Assign a name to the inventory table.
  - c. Define the table by coding the necessary extension specifications.
  - d. Code the calculation specifications necessary to search the table for an item number which matches the item number (ITEMNO) on an order record.
  - e. Why must a resulting indicator be specified in columns 58-59 of the Calculation sheet for the LOKUP operation?
  
2.
  - a. Design alternating format table input records to create two related tables from the following data. Put one set of entries on each record.

<u>Item Number</u>	<u>Costs</u>
10	\$ 10.00
17	75.00
27	125.00
68	1.25
102	.01
700	.05
1640	7.03
2796	72.05
4333	111.11

- b. Define the tables by coding the necessary extension specifications.
  - c. Using ITEM as the search word, code the calculation specifications for a two-table search which makes the appropriate cost available.
  
3. How does a programmer specify that a table search is to satisfy a high, low, or equal condition?
  
4. What indicates whether a table lookup was successful or not?
  
5. How does a programmer reference *looked-up* table data in calculation and output specifications?
  
6. If *looked-up* table data is to be referenced in calculations or output, how can a programmer ensure that the appropriate information will be used?
  
7. How may table data be changed during execution of an RPG II program?
  
8. What must be done to change table data permanently (to exist for more than the present run of the program)?

9. What is a short table?
10. What is the advantage of using a short table?
11. Which specification sheets are necessary to program for output of an entire table at end of job? What is the use of each type of specification required?

**Review Problem**

To perform invoice billing, a corporation processes two input files together in a matching records program. As the following input specifications show, the primary CSMSTR (customer master) file contains a record for every customer who has placed an order, giving the customer number, name, and address. The secondary ORDER file contains data about each order: customer number, item ordered, weight of item, and cost.

IBM International Business Machine Corporation					<b>RPG INPUT SPECIFICATIONS</b>					GX21-9094 U/M 050*								
Program					Punching Instruction	Graphic			Card Electro Number									
Programmer					Date	Punch				Page <span style="border: 1px solid black; padding: 0 5px;">1</span> of <span style="border: 1px solid black; padding: 0 5px;">2</span>	Program Identification <span style="border: 1px solid black; padding: 0 5px;">75</span> <span style="border: 1px solid black; padding: 0 5px;">76</span> <span style="border: 1px solid black; padding: 0 5px;">77</span> <span style="border: 1px solid black; padding: 0 5px;">78</span> <span style="border: 1px solid black; padding: 0 5px;">79</span> <span style="border: 1px solid black; padding: 0 5px;">80</span>							
Line	Form Type	Filename	Sequence	Number (I, N)	Division (O)	Record Identifying Indicator	Record Identification Codes			Field Location		Field Name	Control Level (L1-L9)	Matching Fields or Changing Fields	Field Record Relation	Field Indicators		
							Position	Not (N) C/Z/D Character		Position	Not (N) C/Z/D Character						From	To
01	I	CSMSTR	NS	01			1	CM										
02	I																	
03	I									3	60	CUSTNO	ML					
04	I									7	21	NAME						
05	I	ORDER	NS	02			1	CO		22	36	ADDRESS						
06	I																	
07	I									3	60	CUSTNO	ML					
08	I									7	11	ITEM						
09	I									12	14	WEIGHT						
10	I									15	19	COST						

According to company policy, merchandise is delivered by truck unless a customer has requested delivery by parcel post. To date, the following 15 customers (by number) have requested parcel post service:

174	2109	596	1157	1475
195	169	456	1366	377
2105	2733	1100	290	1977

The customer always pays parcel post charges. The charge is in accordance with the weight of the ordered item, as follows (assume no order weighs more than 30 pounds):

## WEIGHT IN POUNDS

## POSTAL CHARGES

1#	\$0.45
2	.50
3	.50
4	.55
5	.55
6	.55
7	.60
8	.60
9	.65
10	.65
11	.65
12	.70
13	.70
14	.75
15	.75
16	.75
17	.80
18	.80
19	.85
20	.85
21	.85
22	.90
23	.90
24	.95
25	.95
26	.95
27	1.00
28	1.00
29	1.05
30	1.05

Note: Any fraction of a pound over the weight shown takes the next higher rate.

To produce invoices, the billing program must do the following:

- Determine if a customer has requested parcel post delivery.
- If so, determine how much postage is required for the weight ordered.
- Print the amount of postage due on the invoice (printer output file named INVOICE).

This can best be done by setting up three tables:

- A table of customers who have requested parcel post delivery.
- Two related tables of weights and postal rates.

Your job is to:

1. Design table input records for the three tables. The table of customers requiring parcel post service should be created as a pre-execution time short table to allow for frequent additions and deletions. A table of 24 entries should be sufficient for containing additions. The weight and postal rate tables should be loaded at compile time, since they will not be modified.
2. Define and describe the tables with file description and extension specifications.
3. Code the LOKUP operation(s) on a Calculation sheet to determine how much postage is due, if any.
4. Code the output specifications to print the amount of postage due on an order.

1. a. The maximum number of records necessary to contain the table data is 123, with each record containing one item number entry in positions 1-5. The minimum number of records necessary to contain the table data depends on the maximum record length of the device. For 96-column cards, for example, the minimum number is seven records. Records one through six would each contain 19 item number entries punched in columns 1-95. Record seven would contain the remaining nine item number entries punched in columns 1-45. For disk, all entries could reside on a single record, since the maximum record length is 9999.
- b. The table name assigned (for example, TABINV) must meet the following requirements:
  - Three to six characters long
  - May contain any numbers and alphabetic characters (including \$, #, @)
  - Must begin with TAB
  - May not contain embedded blanks

c.

**RPG EXTENSION AND LINE COUNTER SPECIFICATIONS**

Form X21 9091  
Printed in U.S.A.

**IBM** International Business Machine Corporation

Program	Date	Punching Instruction	Graphic Punch	Card Electro Number	Page <input type="text" value="1"/> of <input type="text" value="2"/>	Program Identification	75 76 77 78 79 80
---------	------	----------------------	---------------	---------------------	---	------------------------	-------------------

**Extension Specifications**

Line	Form Type	Record Sequence of the Chaining File		To Filename	Table or Array Name	Number of Entries Per Record	Number of Entries Per Table or Array	Length of Entry	P.B.L.R. Decimal Positions Sequence (A, D)	Table or Array Name (Alternating Format)	Length of Entry	P.B.L.R. Decimal Positions Sequence (A, D)	Comments
		Number of the Chaining Field	From Filename										
0 1	E				TABINV	1	123	5	0				1 ENTRY/RECORD
0 2	E	*	OR										
0 3	E				TABINV	19	123	5	0				MANY ENTRIES/REC
0 4	E												
0 5	E												
0 6	E												
0 7	E												
0 8	E												
	E												
	E												

**Line Counter Specifications**

Line	Form Type	Filename	1		2		3		4		5		6		7		8		9		10		11		12	
			Line Number	F.L. or Channel Number	Line Number	O.L. or Channel Number	Line Number	Channel Number	Line Number	Channel Number	Line Number	Channel Number	Line Number	Channel Number	Line Number	Channel Number	Line Number	Channel Number	Line Number	Channel Number	Line Number	Channel Number	Line Number	Channel Number	Line Number	Channel Number
1 1	L																									
1 2	L																									
	L																									



d.

<b>IBM</b> International Business Machine Corporation										<b>RPG CALCULATION SPECIFICATIONS</b>										Form 53X21 9093 Printed in U.S.A.																			
Program										Punching Instruction										Graphic										Card Electro Number									
Programmer										Date										Punch										Page 1 2 of 75 76 77 78 79 80									

Line	Form Type	Indicators										Factor 1	Operation	Factor 2	Result Field		Resulting Indicators			Comments			
		And			Or			Not							Name	Length	Arithmetic	Plus	Minus		Zero		
0 1	C											ITEMNO		LOKUPTABINV									2LIS ITM IN STOCK
0 2	C																						
0 3	C																						
0 4	C																						
0 5	C																						

e. A resulting indicator must be set on if the item number is in the table to indicate whether the search is successful or not.

2. a. Nine records required for nine pairs of item number/cost entries:

1 001001000

4 006800125

7 164000703

2 001707500

5 010200001

8 279607205

3 002712500

6 070000005

9 433311111

b.

<b>IBM</b> International Business Machine Corporation										<b>RPG EXTENSION AND LINE COUNTER SPECIFICATIONS</b>										Form X21-9091 Printed in U.S.A.																			
Program										Punching Instruction										Graphic										Card Electro Number									
Programmer										Date										Punch										Page 1 2 of 75 76 77 78 79 80									

Extension Specifications																					
Line	Form Type	Record Sequence of the Chaining File										To Filename	Table or Array Name	Number of Entries Per Record	Number of Entries Per Table or Array	Length of Entry	Decimal Positions Sequence (A/D)	Table or Array Name (Alternating Format)	Length of Entry	Decimal Positions Sequence (A/D)	Comments
		Number of the Chaining Field					From Filename														
0 1	EM												TABITM	1	9	4	0	DATA	5	2	
0 2	EM																				
0 3	EM																				

C.

IBM International Business Machine Corporation		RPG CALCULATION SPECIFICATIONS																				Form G421-8093 Printed in U.S.A.	
Program						Punching Instruction				Graphic				Card Electro Number				Page 1 2 of ___		Program Identification 76 78 77 78 79 80			
Programmer						Date				Punch													
C	Line	Form Type	Control Level (LO/LB, LR, SR, AN/OR)	Indicators			Factor 1	Operation	Factor 2	Result Field		Resulting Indicators			Comments								
				And	And	And				Name	Length	Arithmetic	Plus	Minus		Zero							
				Not	Not	Not						1 > 2	1 < 2	1 = 2									
0 1	C						ITEM	LOKUP	TABITM	TABCST					21								
0 2	C																						
0 3	C																						
0 4	C																						

3. To search for a high condition enter a resulting indicator in columns 54-55 on the same line of the Calculation sheet as you have specified the LOKUP operation code.

To search for a low condition, enter a resulting indicator in columns 56-57.

To search for an equal condition, enter a resulting indicator in columns 58-59.

If more than one condition will satisfy a search, a resulting indicator should be entered for each condition. The same resulting indicator may be used for both conditions or a different indicator may be specified for each condition.

4. The resulting indicator specified for the high, low or equal condition (columns 54-55, 56-57, or 58-59) will be set on if the particular search condition is satisfied. The indicator will be off if the search was unsuccessful.
5. In any calculation and output specifications which follow a LOKUP operation, use of a table name refers to the table data found by the lookup.
6. The resulting indicator specified with the LOKUP operation can be used to condition calculation and output specifications that follow the LOKUP.
7. When a table name is specified as the result field of a calculation operation, other than LOKUP, the result of the operation is placed in the table, replacing the last element looked-up. This assumes that a search was previously performed on the specified table.
8. The table input records must be recreated. If calculation specifications change table data during execution, the programmer may code specifications which cause the changed data to be output as new table records. The new output records can then be read in place of the old table input records the next time the program is run.
9. A short table refers to table input records which contain fewer entries than the extension specifications indicate the table can contain.
10. The advantage of using a short table is that entries may be added to a table without changing the extension specifications which describe the table.

11. File Description sheet – assigns the name and device of the output file

Extension sheet – indicates automatic table output at end of job when name of the output file is entered in columns 19-26

Input, Calculation, and Output sheets – not required

### **Answer to Review Problem**

1. *Customer Number Table Input Records*

Since the largest customer number is four digits in length, each entry would require four positions. A customer number less than four digits should be padded in front of the number with zeros or blanks, to form a 4-position entry.

The simplest table input records to design and maintain for this table would contain one entry per record in positions 1-4. With this design, 15 records would be necessary for the 15 customer numbers. To add entries to the table, merely add table input records.

An alternative method is to place the 15 entries in positions 1-60 of a single record. A record can contain a maximum of 24 4-digit entries. Entries may be added to the table by placing new customer numbers in unused positions of the same record. However, to delete entries, the entire record would have to be recreated.

#### *Weight and Postal Rate Table Input Records*

The WEIGHT field from the ORDER input file is to be used as the search word for locating the appropriate weight in the table. Therefore, the weight table entries must be the same length and format as the search word: three digits in length with one decimal position. The corresponding postal rates can be three digits with two decimal positions, to accommodate the largest entry 1.05.

Using an alternating format, one record could be used for each pair of entries (positions 1-6), for a total of 30 table input records. Otherwise, the first 16 pairs of entries could be contained in positions 1-96 of one record with the remaining 14 pairs contained in positions 1-84 of a second record.

If separate records are to be used for each table, the 30 weight entries could be in columns 1-90 of one record, and the 30 postal rate entries in columns 1-90 of another record. Using separate table format, 30 records would be required for each table, if each record contained only one entry.

2. Specifications to define and describe customer number table:

### File Description Specification

Line	Form Type	Filename	File Type				Mode of Processing				Device	Symbolic Device	File Addition/Unordered		
			File Designation	End of File	Sequence	File Format	Length of Key Field or of Record Address Field	Record Address Type	Type of File Organization or Additional Area	Overflow Indicator			Label S/N/E/R	Name of Label Exit	Number of Tracks for Cylinder Overflow
02	F	CUSNUM	IT												
03	F	CUSMSTR	IP	AF											
04	F	ORDER	IS	A											
05	F	INVOICE	O												
06	F														

**Annotations:**

- Indicates this table file further described on extension sheet.
- The devices used for these files can vary, depending which system and configuration you use.

Pre-execution time table file containing table-input records must be loaded before other data files.

### Extension Specifications

Line	Form Type	Record Sequence of the Chaining File		To Filename	Table or Array Name	Number of Entries Per Record	Number of Entries Per Table or Array	Length of Entry	P/B/L/R	Decimal Positions Sequence (A/D)	Table or Array Name (Alternating Format)	Length of Entry	P/B/L/R	Decimal Positions Sequence (A/D)	Comments
		Record Sequence	Number of the Chaining Field												
01	E			CUSNUM	TABCUS	1	24	4				1			1 ENTRY/RECORD
02	E	*			OR										
03	E	*			OR										
04	E	*			OR										
05	E			CUSNUM	TABCUS	24	24	4							MULT ENT PER/RECD
06	E														
07	E														
08	E														

**Annotations:**

- Same length as search word.
- Short table: 9 entries may be added to the 15 entries present.

Specifications to define weight and postal rate tables:

### Extension Specifications

Line	Form Type	Record Sequence of the Chaining File		To Filename	Table or Array Name	Number of Entries Per Record	Number of Entries Per Table or Array	Length of Entry	P/B/L/R	Decimal Positions Sequence (A/D)	Table or Array Name (Alternating Format)	Length of Entry	P/B/L/R	Decimal Positions Sequence (A/D)	Comments
		Record Sequence	Number of the Chaining Field												
01	E				TABWGT	16	30	3	1		TABRAT	3	2		MULT PAIRS/RECORD
02	E	*			OR										
03	E	*			OR										
04	E	*			OR										
05	E				TABWGT	1	30	3	1						1 ENTRY/RECORD
06	E				TABRAT	1	30	3	2						1 ENTRY/RECORD
07	E	*			OR										
08	E				TABWGT	30	30	3	1						MULT ENTRIES/RECD
	E				TABRAT	30	30	3	2						MULT ENTRIES/RECD

**Annotations:**

- No entry indicates compile time table
- File Description sheet not required since they are compile time tables.
- Alternating Format

3. Calculation specifications for LOKUP operations:

Line 01 – When a CSMSTR record is read (01 on), use CUSTNO field as search word to determine if that customer requires parcel post service. Indicator 21 set on if customer number in table.

Line 03 – When an ORDER record is read (02 on) and that customer requires parcel post (21 on from successful search), then search weight table using WEIGHT field as search word. Indicator 23 set on when correct weight found (same number of pounds or next higher entry if weight is in fractions of pounds). When 23 is set on, correct postal charge is available from postal rate table.

IBM		RPG CALCULATION SPECIFICATIONS					Form GX21-9093 Printed in U.S.A.									
Program	Programmer	Date	Punching Instruction	Graphic	Card Electro Number	Page 1 of 2					Program Identification 75 76 77 78 79 80					
Line	Form Type	Control Level (LO 1-9, LR, SR, AN, OPI)	Indicators		Factor 1	Operation	Factor 2	Result Field		Resulting Indicators			Comments			
		And		And				Name	Length	Decimal Positions	Arithmetic					
										High	Low	Equal				
										Half Adjust (H)	Compare					
										1 > 2		1 < 2		1 = 2		
										Lookup (Factor 2) is						
										High		Low		Equal		
										53		54		55		
01	C		Ø1		CUSTNO	LOKUPTABCLUS								21	PAR POST DELIV?	
03	C		Ø2	21	WEIGHT	LOKUPTABWGT	TABRAT			23				23	FIND POST RATE	

4. Output specifications to print postal charge on invoice:

Line 01 – If customer required parcel post and correct postage charge has been determined (23 on), print the postage chart from the postal rate table, TABRAT.

IBM		RPG OUTPUT SPECIFICATIONS					Form GX21-9090 U/M 050* Printed in U.S.A.															
Program	Programmer	Date	Punching Instruction	Graphic	Card Electro Number	Page 1 of 2					Program Identification 75 76 77 78 79 80											
Line	Form Type	Filename	Output Indicators			Field Name		Edit Codes		Commas		Zero Balances to Print		No Sign		CR		-		X = Remove Plus Sign		
		OR		AND		*AUTO		B/A/C/T/9/R		Yes		Yes		1		A		J		Y = Date		
		A		D				End Position in Output Record		Yes		No		2		B		K		L = Field Edit		
								P/B/L/R		No		Yes		3		C		L		Z = Zero Suppress		
										No		No		4		D		M				
										Constant or Edit Word												
01	O	INVOICE.D	23	Ø2		TABRAT																
										45	'	\$	.	'								

**CHAPTER 9 DESCRIBES:**

Use of arrays and RPG II coding to reference an entire array or individual elements of the arrays.

XFOOT operation code.

LOKUP operation code.

**BEFORE READING THIS CHAPTER YOU SHOULD BE ABLE TO DESCRIBE:**

Use of and coding for tables.

Exception output.

RPG II object cycle.

OR relationship.

**AFTER READING THIS CHAPTER YOU SHOULD BE ABLE TO:**

Determine the use of arrays as opposed to the use of tables.

Define an array on the Extension sheet.

Code problems that reference all elements in an array.

Code problems referencing individual elements in an array.

Define and code the LOKUP operation code with arrays.

Describe data and store it in an array.

*Note:* You can use the review questions contained in *Review 9* at the end of this chapter to test your comprehension of the chapter. Answers follow the review questions.

## INTRODUCTION

An array is a continuous series of data fields stored side by side so they can be referenced as a group. In an array, each individual data field is called an *element*. Figure 9-1 shows an array of 12 elements containing the total sales for each month of the year. Each element of the array has the same characteristics; that is, each contains data in the same format (alphanumeric or numeric), of the same length, and with the same number of decimal positions. An array element may be positive, negative, or unsigned; within a numeric array, elements may be positive or negative.

An array is very similar in concept to a table. Both arrays and tables are set up by coding extension specifications. The type of data which you can put in an array is the same as that which you can put in a table. The data can be punched on cards, keyed in by the operator, or written on disk or tape. The data can be loaded into an array at compilation time or just before execution time. An array can also be built from data extracted from normal input files or from data produced during the program as a result of calculations. The way data is arranged in storage is the same for tables and arrays; one element of data immediately follows another. The uses, however, of tables and arrays differ considerably.

## WHEN TO USE AN ARRAY INSTEAD OF A TABLE

In most cases, tables contain constant data such as tax rates, shipping instructions, or discount rates. The constant data is then used for calculations or printing with variable transaction data. Arrays are generally used for variable data and totals which are used independently of the variable transaction data.

You should use arrays instead of tables when you want to reference all elements at one time. Arrays can reduce the number of RPG II specifications you must code for such a program, as well as the time required to reference the entries. Arrays should also be used when you are able to directly reference a data item within a group of items and do not need to do a look-up based on a search word.

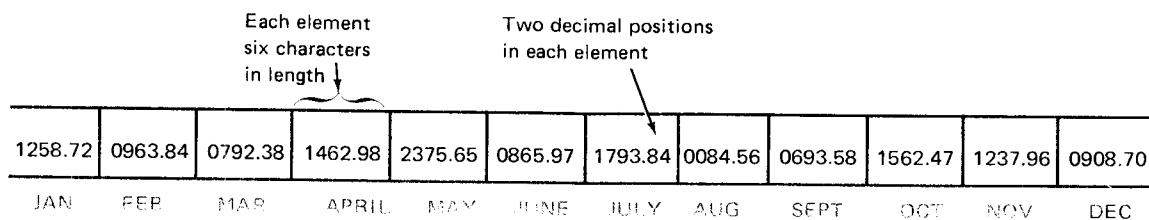

Figure 9-1. 12-Element Numeric Array

## DEFINING AN ARRAY

You tell the RPG II program that you wish to set up an array by coding extension specifications in much the same way as you would code them for tables. As shown in Figure 9-2, coding on the Extension sheet varies slightly, depending on when the array data is to be read into the array that is set up by the RPG II compiler. Array data can be stored in the array at three different times (see also *Loading Arrays*):

1. *Compile time.* The array records immediately follow, and are compiled with, the source program. (If you have a Card System, both array data and source program are loaded from the secondary hopper.)
2. *Pre-execution time.* The array records are read like any other data file, except that they are all read before any processing is done. (If you have a Card System, both array records and object program are loaded from the secondary hopper.)
3. *Execution time.* The array is loaded from information in input records or data generated by calculations.

The following Extension sheet entries are used to define and describe arrays (see Figure 9-2):

*Columns 11-18 (From Filename):* Pre-execution time arrays are read from an input file similar to other data files. The name of the file containing the array must be entered in columns 11-18 of the Extension sheet. This file must be designated as a table file in column 16 of the File Description sheet. A table file is read completely and data is loaded into the array before execution of the program begins. The same MFCU file can be named in these columns for more than one array. Input files on other devices can contain only one array. On the Card System, pre-execution time arrays must be loaded from the secondary MFCU hopper.

RPG EXTENSION AND LINE COUNTER SPECIFICATIONS

Form X21-9091  
Printed in U.S.A.

**IBM** International Business Machine Corporation

Program	Punching Instruction	Graphic	Card Electro Number
Programmer	Date	Punch	

Page  1  2 of  Program Identification  75  76  77  78  79  80

Extension Specifications

Line	Form Type	Record Sequence of the Chaining File		To Filename	Table or Array Name	Number of Entries Per Record	Number of Entries Per Table or Array	Length of Entry	P/B/L/R Decimal Positions Sequence (A/D)	Table or Array Name (Alternating Format)	Length of Entry	P/B/L/R Decimal Positions Sequence (A/D)	Comments
		Number of the Chaining Field	From Filename										
0 1	E				ARRAYC	3	8	12	4				COMPILE
0 2	E		INFILE		ARRAYP	12	250	5	A				PRE-EXECUTION
0 3	E				ARRAYE		10	10	0				EXECUTION
0 4	E												
0 5	E												

Figure 9-2. Defining Arrays

**Columns 19-26 (To Filename):** If you want your entire array to be written to an output file at end of job, enter the name of the output file in columns 19-26. You cannot use the To Filename entry to write execution time arrays to an output file; instead you must use output specifications (see *Output of an Entire Array*, later in this chapter).

**Columns 27-32 (Table or Array Name):** All arrays used in your program must be assigned a name of six characters or less which is entered in columns 27-32. The rules for naming arrays are similar to those for naming tables; an array name can consist of any combination of alphabetic characters and numbers. However, while the first character must be an alphabetic character, an array name cannot begin with the letters TAB. This is the way the compiler distinguishes between an array and a table.

**Columns 33-35 (Number of Entries Per Record):** For compile time and pre-execution time arrays, enter the number of array elements in each input record. These columns must be blank for execution time arrays.

**Columns 36-39 (Number of Entries Per Table or Array):** These columns are used to enter the number of elements in the array (from 1 to 9999). This number should be entered so that the last digit is in column 39.

**Columns 40-42 (Length of Entry):** The length of each element (number of characters, including blanks) should be specified in columns 40-42, with the number ending in column 42. The length, which must be the same for every element in the array, cannot be greater than 255.

**Column 43 (Packed/Binary):** Disk or tape users may specify in column 43 that pre-execution time array data is in packed decimal or binary format. On a disk system, 80-column card users can specify packed pre-execution time data.

**Column 44 (Decimal Positions):** If the elements in an array are numeric, the number (0-9) of digits to the right of the decimal point should be entered in column 44. Even if no decimal positions are present, a zero must be specified if the elements are to be considered numeric. A blank in column 44 indicates that the elements are to contain alphanumeric data. Remember, however, that if arithmetic operations are to be performed on the elements, the array must be defined as numeric.

**Column 45 (Sequence):** If your array data is in sequence, enter A (ascending) or D (descending) in column 45. Sequence is not checked for execution time arrays, but this column must contain an entry if high or low look-up is used (see *LOKUP of an Array*).

**Columns 46-57 (Alternating Arrays):** Columns 46 through 57 are used if two related arrays are set up in an alternating format on input records. Alternating arrays cannot be described with execution time arrays.

The extension specifications only reserve the appropriate space in storage for the array. In a following section, you will learn how data is stored in the array.



## REFERENCING ALL ELEMENTS IN AN ARRAY Array to Array Calculations

Suppose a company employs 15 sales clerks whose daily sales are recorded on a punched card (SALES). As Figure 9-3 shows, field 1 contains sales for clerk #1, field 2 for clerk #2, and so on. There is one SALES record for each day. In addition to a daily amount, the company wishes to have a monthly sales total for each clerk. Therefore, at the end of the month, the daily sales amounts for a clerk must be accumulated.

As shown in Figure 9-4, an array (MONTH) of 15 elements is set up to contain the monthly totals. Another array, called DAY, could be set up to contain the 15 sales amounts for one particular day. The daily sales record is read and each clerk's sales amount is placed in the appropriate element of array DAY.

Once the first SALES record is read and the data stored in the DAY array, the 15 elements of DAY are added to the 15 elements of MONTH. In other words, element 1 of DAY is added to element 1 of MONTH, element 2 to element 2, and so on (Figure 9-5).

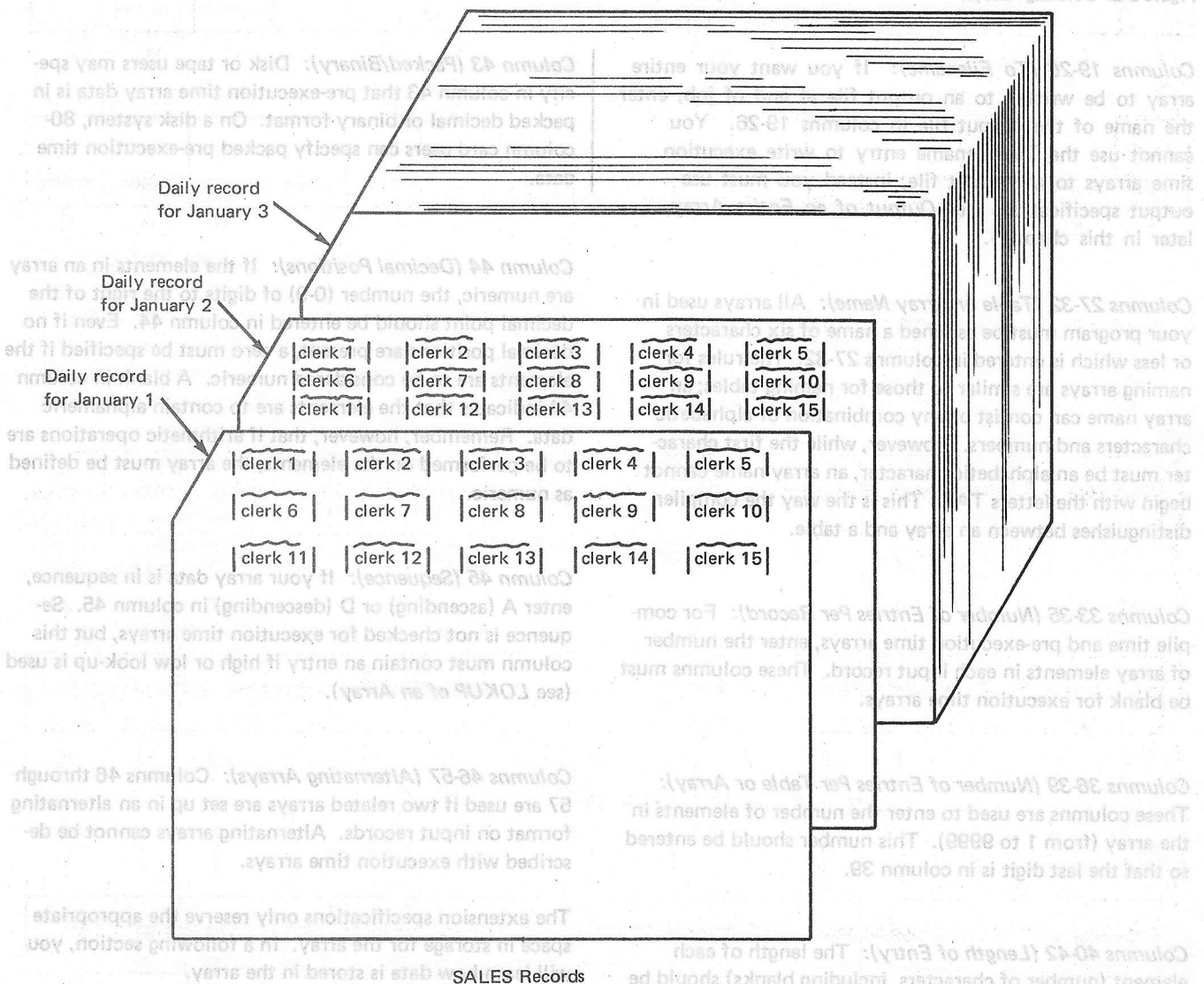

Figure 9-3. SALES Records

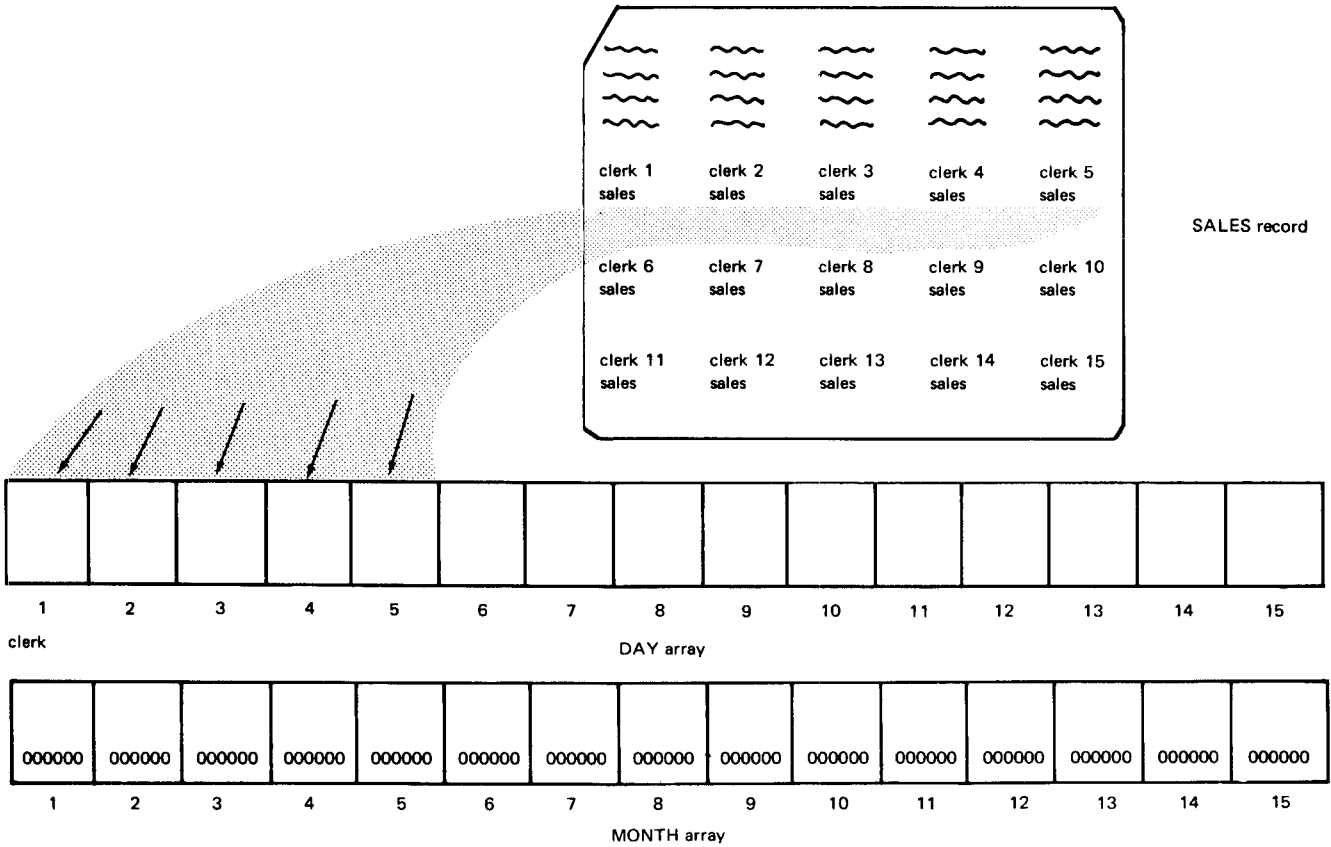

Figure 9-4. Using Arrays to Contain Sales Data

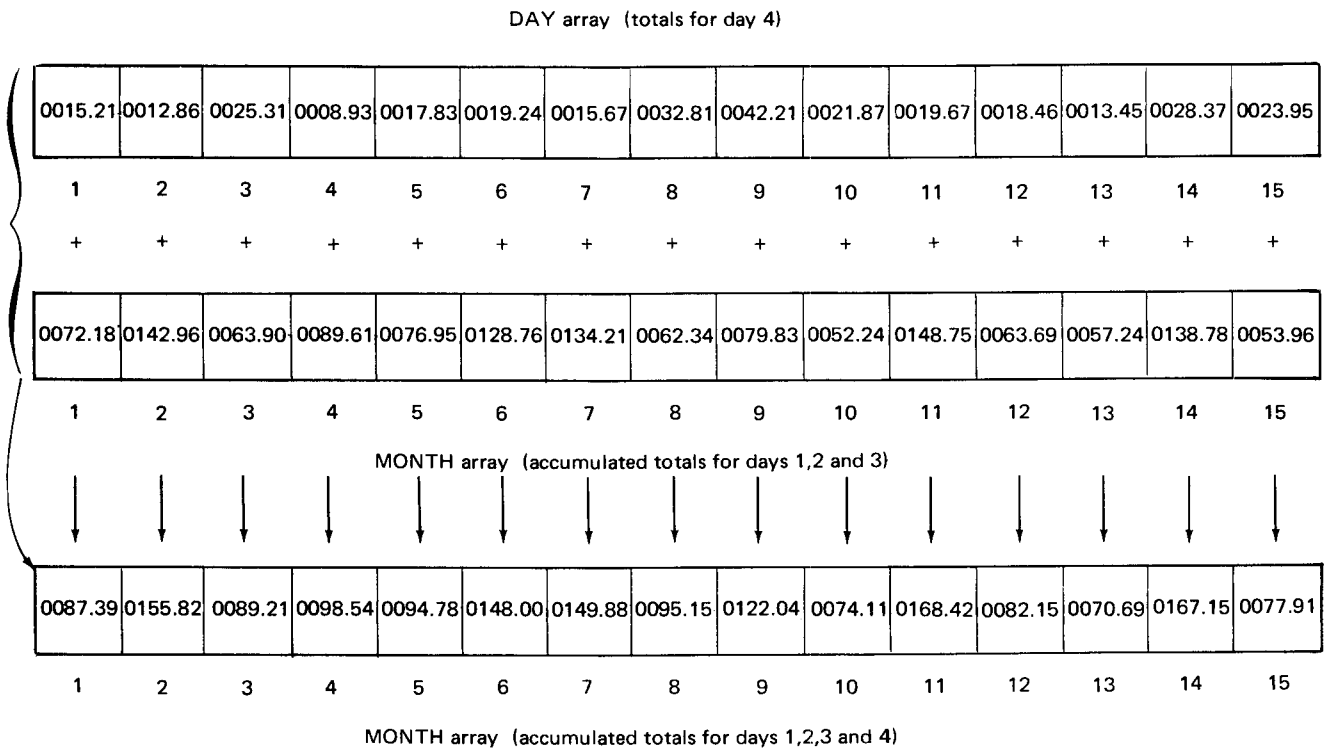

Figure 9-5. Adding One Array to Another Array

The 15 accumulated sale amounts (results of the additions) are stored in MONTH. Then, another SALES card is read into the DAY array. The new DAY fields are then added again to the accumulated totals in MONTH.

This method is similar to using two tables and adding an entry from one table to an entry in the other table. However, performing the operations using tables requires more specifications than to doing the job using arrays.

With tables, you must reference each element (sales amount for a clerk) separately. First, you must perform a table lookup to find the appropriate sale amount from the day table. Of course, since you do not know the amount of each sale, you cannot search the day table directly. A related table of sales clerk numbers must be set up and searched. Only after you find the appropriate sales clerk entry is the corresponding sale amount in the day table made available. Then you must lookup the corresponding element of the month table. At this point, use of the table names in calculations or output would finally refer to each

of the entries looked up. An addition operation would then be required to add the two entries and place the result in the month table. After all this, you have accumulated a total for only one of the sales clerks.

To repeat the same procedure 14 more times for the other sales clerks' entries, the program must read 14 records and go through 14 program cycles. This occurs when you use a table name in specifications. The name refers to only one element, the entry just looked up.

On the other hand, if you have defined your groups of data as arrays rather than tables, only one calculation specification is necessary. The name of an array actually refers to all of the elements in that array. Adding the array DAY to the array MONTH causes every element of one array to be added to corresponding elements of the other array (1 to 1, 2 to 2, 3 to 3, etc.). Since the MONTH array is specified under Result Field, the result of each addition is placed back into the appropriate element of MONTH (Figure 9-6).

Form X21-9091  
Printed in U.S.A.

**IBM** International Business Machine Corporation

Program \_\_\_\_\_ Punching Instruction \_\_\_\_\_ Graphic \_\_\_\_\_ Card Electro Number \_\_\_\_\_  
 Programmer \_\_\_\_\_ Date \_\_\_\_\_ Punch \_\_\_\_\_

Page 1 2 of \_\_\_\_\_ Program Identification 75 76 77 78 79 80

### RPG EXTENSION AND LINE COUNTER SPECIFICATIONS

Line	Form Type	Record Sequence of the Chaining File		To Filename	Table or Array Name	Number of Entries Per Record	Number of Entries Per Table or Array	Length of Entry	P/B/L/R Decimal Positions Sequence (A/D)	Table or Array Name (Alternating Format)	Length of Entry	P/B/L/R Decimal Positions Sequence (A/D)	Comments
		From Filename	Number of the Chaining Field										
0 1	E				MONTH			15	6 2				TO ACCUM MNTH SLS
0 2	E				DAY			15	6 2				TO HOLD DAY SALES
0 3	E												

Form GX21-9093  
Printed in U.S.A.

**IBM** International Business Machine Corporation

Program \_\_\_\_\_ Punching Instruction \_\_\_\_\_ Graphic \_\_\_\_\_ Card Electro Number \_\_\_\_\_  
 Programmer \_\_\_\_\_ Date \_\_\_\_\_ Punch \_\_\_\_\_

Page 1 2 of \_\_\_\_\_ Program Identification 75 76 77 78 79 80

### RPG CALCULATION SPECIFICATIONS

Line	Form Type	Control Level (L0, L3, LR, SR, AN/OR)	Indicators			Factor 1	Operation	Factor 2	Result Field		Resulting Indicators	Comments
			And	And	Not				Name	Length		
0 1	C					MONTH	ADD	DAY	MONTH		Plus Minus Zero Compare 1 > 2 1 < 2 1 = 2 Lookup(Factor 2) is High Low Equal	ACCUM SALES
0 2	C											

Figure 9-6. Referencing All Elements of an Array

Notice on the Calculation sheet in Figure 9-6 that no resulting indicators have been specified for this arithmetic operation. When an array name is specified in a calculation, the operation is performed on every element of the array. Therefore, there are a multiple number of results; in this case, 15 sales totals. A resulting indicator can indicate the condition of only a single result. Thus, resulting indicators cannot be used when referencing an entire array as a Result Field. There are two exceptions when resulting indicators can be used, as explained under *Adding All Elements Within An Array and Searching An Array For A Particular Element*.

### Operations Which Can be Performed on Arrays

As mentioned, an operation to be performed on an array is performed for every element in the array. A result is then produced for each element operated on. For this reason, certain operations cannot be performed on arrays, because the results have no meaning. The operation codes COMP (compare), TESTZ (test zone), MVR (move remainder), TESTB (test bit), BITON (set bits on), BITOF (set bits off), and DSPLY (display) cannot be used with an array.

### Performing Operations on Arrays of Different Lengths

In the last example, all arrays used in an operation were of the same length; Factor 1, Factor 2, and the result array each contained 15 elements. Thus the operations were carried out until all elements were processed.

Suppose, as shown in Figure 9-7, that DAY only contains 12 elements while the MONTH array contains 15 elements. In such a case, the operations are performed only until the last element in the shortest array has been processed. Thus, the 12 elements of DAY are added to the first 12 elements of MONTH, and the 12 results are placed in the first 12 elements of MONTH. The remaining three elements of the result field (MONTH) remain unchanged. Likewise, if the result array is shorter than any of the factors (arrays), the operation is repeated only for the number of elements in the shortest (result) array.

### Calculations Using Arrays and Single Fields (or Constants)

Another way in which you can perform calculations on an entire array is by adding (or multiplying, etc.) the same value to every element in the array. For example, suppose the sales clerks are to receive a commission of 10 percent of their sales, to be paid at the end of the month. After all daily sales have been accumulated into the MONTH array, you want to multiply each of the 15 elements in MONTH by the value .10 and to place the commission amounts in another 15-element array called COMMIS.

To do this, it is not necessary to set up a 15-element array for the commission rates, with each element containing the value .10. In an array operation, when one of the factors is a field (containing a value) or a constant, the operation is performed using the same field or constant on every element in the array.

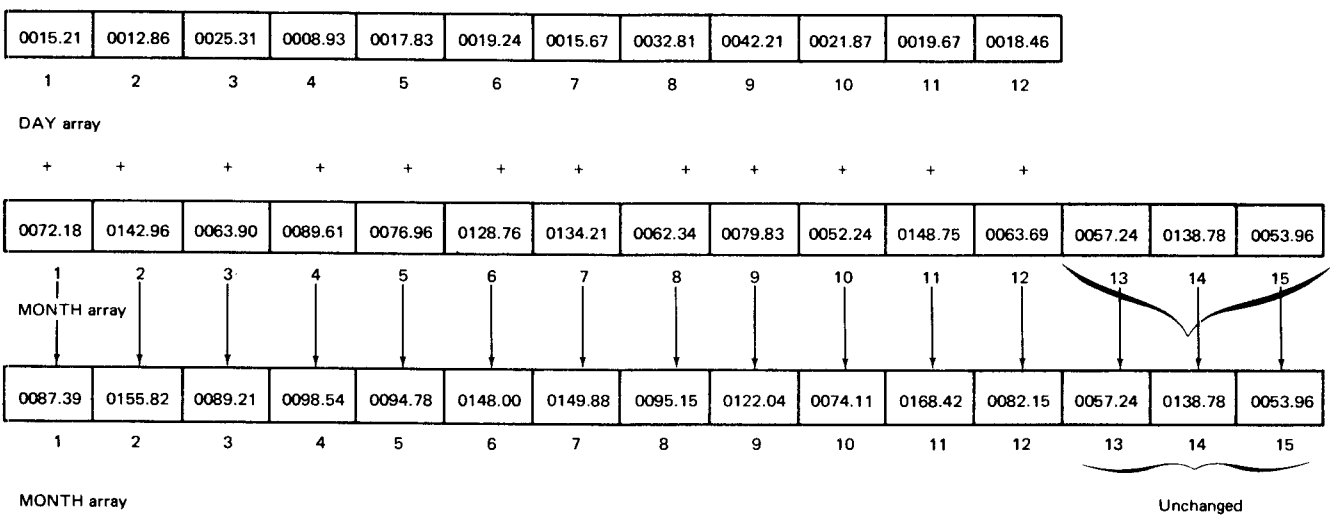

Figure 9-7. Operations on Arrays of Different Lengths



**IBM** International Business Machine Corporation Form GX21-9093  
Printed in U.S.A

**RPG CALCULATION SPECIFICATIONS**

---

Program \_\_\_\_\_ Card Electro Number \_\_\_\_\_  
 Programmer \_\_\_\_\_ Date \_\_\_\_\_

Punching Instruction: Graphic \_\_\_\_\_ Punch \_\_\_\_\_

Page 1 2 of \_\_\_ Program Identification: 75 76 77 78 79 80

Line	Form Type Control Level (LD, L9, L, P, SR, AM, OR)	Indicators					Factor 1	Operation	Factor 2	Result Field		Resulting Indicators Arithmetic Plus   Minus   Zero Compare 1 > 2   1 < 2   1 = 2 Lookup Factor 2 list High   Low   Equal	Comments
		And	And	And	And	And				Name	Length		
0 1	C							XFOOTDAY		TOTDAY	72		

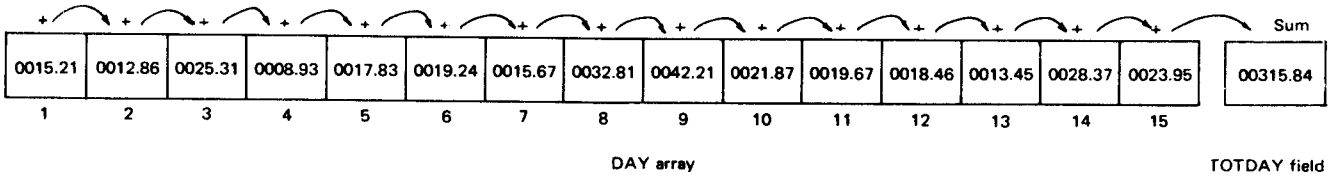

Figure 9-9. Adding All Elements of an Array

**Output of an Entire Array**

You may want to have an entire array written or punched out. Perhaps you want to look at the contents of the array at some point during the program run or at the end of the run. Or, you may want to have array elements put out to be used as input the next time the program is run. Output of an entire array can be specified in two ways, with extension specifications or with output specifications.

**By Extension Specifications**

Like tables, compile time arrays and pre-execution time arrays can be written out at end of job by simply entering the name of the output file under To Filename (columns 19-26) on the Extension sheet (see Figure 9-10). The output file must be named on the File Description sheet, but no output specifications are necessary. The entire array, including unused elements (blanks or zeros), is put out.

With the Extension specifications shown in Figure 9-10, the array, ARRAY1, is put out automatically at end of job.

The data output may not be exactly the same as the data input. Your program can change or update array entries, causing modified data to be put out, not the original data. Except for printer output, however, the format of the array output records will be the same as the input records.

**By Output Specifications**

The second method of specifying output of an entire array is with output specifications. By specifying the array name under Field Name (columns 32-37) on the Output sheet, all elements within the named array are punched, printed, or written on the indicated output file (Figure 9-11). All types of arrays, compile, pre-execution, and execution, can be put out using output specifications.

Any output conditioning indicators specified in columns 23 through 31 of the Output sheet determine when during the program the array elements will be printed or punched. If no indicators are specified, the entire array is printed or punched every time a record is processed. Indicators can be specified to put out array data during detail cycles or at total time. You may want to put out array data at total time by customer or inventory item, for example, to be used as input to subsequent update runs.

**RPG EXTENSION AND LINE COUNTER SPECIFICATIONS**

Form K21-9091  
Printed in U.S.A.

Program		Punching Instruction		Graphic Punch		Card Electro Number		Page 1 2 of		Program Identification 75 76 77 78 79 80	
Programmer		Date									

**Extension Specifications**

Line	Form Type	Record Sequence of the Chaining File		To Filename	Table or Array Name	Number of Entries Per Record	Number of Entries Per Table or Array	Length of Entry	P/B L/R	Decimal Positions Sequence (A/D)	Table or Array Name (Alternating Format)	Length of Entry	P/B L/R	Decimal Positions Sequence (A/D)	Comments	
		Number of the Chaining Field	From Filename													
0 1	E			OUTFILE	ARRAY1	10	100	5	2							
0 2	E															
0 3	E															
0 4	E															
0 5	E															
0 6	E															

Causes entire array to be put out at end of job.

**File Description Specification**

Line	Form Type	Filename	File Type		Mode of Processing		Device	Symbolic Device	Label S/N/E/M	Name of Label Exit	Extent Exit for DAM	File Addition/Unordered	
			File Designation	End of File	Length of Key Field or of Record Address Field	Record Address Type						Number of Tracks for Cylinder Overflow	Number of Extents
0 2	F	OUTFILE	O				PRINTER						
0 3	F												
0 4	F												
0 5	F												
0 6	F												

**Figure 9-10. Specifications for Output of an Entire Array at End of Job**

**RPG OUTPUT SPECIFICATIONS**

GX21-9090 U/M 050\*  
Printed in U.S.A.

IBM International Business Machine Corporation

Program: \_\_\_\_\_  
 Programmer: \_\_\_\_\_ Date: \_\_\_\_\_  
 Punching Instruction: \_\_\_\_\_

Graphic: \_\_\_\_\_  
 Punched: \_\_\_\_\_

Card Electro Number: \_\_\_\_\_

Page 1 of 2  
 Program Identification: \_\_\_\_\_

Line	Form Type	Filename	Type (H/D/T/E)	Stacker # / Fetch (F)				Space			Skip			Output Indicators							Field Name	Edit Codes B/A/C/L/R	End Position in Output Record	P/B/L/R	Constant or Edit Word																
				Before	After	Before	After	Before	After	Not	Not	Not	And	And	Commas	Zero Balances to Print	No Sign	CR	-	X					Y	Z															
0 1	O	REPORT	T																																						
0 2	C																																								

Figure 9-11. Output of an Entire Array

RPG II determines where the array data is to be put out on a card, printer file, disk or tape by the end position column you specify in columns 40 through 43 of the Output sheet. The array elements are put out such that the last element of the named array ends in the column indicated. Note, however, that if all elements in the array cannot be put out on one output record, the array elements must be referenced separately on the Output sheet. Output of individual elements will be discussed later.

The output of an entire array by means of output specifications requires only one specification. An entire array can be written, printed or punched at any time during the run or at end of job, depending on how the output specification is conditioned. Again, during the run, this is possible only if a single output record can contain this entire array.

You must specify how you want the data elements to appear on the output record. Alphameric elements appear on an output record just as they appear in storage; however, numeric array elements may be edited or unedited. If no editing is specified, the elements are printed or punched just as they appear in storage, with the last element ending in the end position column of the output file. In other words, one element will immediately follow another with no punctuation and no blanks between elements.

Usually, printed array output is easier to read and has a better appearance if edit codes or edit words are used to punctuate the data and insert spaces between elements. If punched output, disk output, or tape output is desired, generally the array output records are used as input the next time the program is run. Therefore, editing is usually not specified, so the elements will be in the appropriate format to be used as input.

Editing affects the position which is specified as the end position of the output record. If each element in a 5-element array contains seven characters, 35 positions would be necessary to output the entire array in unedited form. On the other hand, if punctuation and blanks are inserted for each element, the number of positions required increases. When specifying an end position, you must allow enough positions to output all edited elements.

Regardless of whether editing is specified or not, when output of an entire array is performed, every element of that array is put out in the same format. If an edit code or edit word is specified, every element is edited in the same way. Since all elements of an array contain the same type of information, ordinarily you want the elements punctuated in the same way. If, however, one element must be edited differently from another element in the same array, you must put out the elements separately. The means of referencing individual elements of an array is discussed later in this section.

When an edit code is specified in column 38 of the Output sheet, every element of the named array will be punctuated accordingly. Furthermore, any edit code specified for an entire array also causes two blank spaces to be inserted between each element. The insertion of blanks is taken into consideration by the program so that the last element ends in the position specified.



As shown in Figure 9-12, the edit code 3 causes all five elements of the SALES array to be printed with decimal points inserted, leading zeros suppressed, and zero balances present. In addition, two blanks are automatically printed before each element since an edit code was specified.

If no edit code specifies exactly how you want the array fields to be edited, you can specify the punctuation by using an edit word (columns 45-70). In this way, you can edit array elements with dollar signs, zero suppression, blanks, constant words, or any combination of punctuation desired. When edit words are used, all punctuation must be specified. Unlike edit codes, edit words do not cause two

blanks to be automatically inserted in the output record before each array element. Figure 9-13 shows an edit word specified without blanks; one element of SALES immediately follows the next on the output record. Any extra blanks which are to appear must be indicated in the edit word by an &. Notice, in Figure 9-14 that the two blanks specified are to be printed as part of every element. Thus, the second blank following the last element will be the character which ends in the end position column. Notice that an additional two columns have been allowed for each element (five elements). The end position column has thus been increased by ten over that in Figure 9-13.

**RPG OUTPUT SPECIFICATIONS**

GK21-9090 U/M 050\*  
Printed in U.S.A.

Program		Punching Instruction		Graphic Punch		Card Electro Number		Page 1 2 of ___		Program Identification 75 76 77 78 79 80				
Programmer		Date												

Line	Form Type	Filename	Type (H/O/T/E)		Space	Skip	Output Indicators					Field Name	Edit Codes	End Position in Output Record	Constant or Edit Word	Commas	Zero Balances to Print	No Sign	CR	-	X = Remove Plus Sign	Y = Date Field Edit	Z = Zero Suppress	
			Before	After			And	And	Not	Not	Not													Not
0 1	O	REPORT	D									*AUTO												
0 2	O											SALES	3B	112										

00456	01783	29684	00000	08063	Array
-------	-------	-------	-------	-------	-------

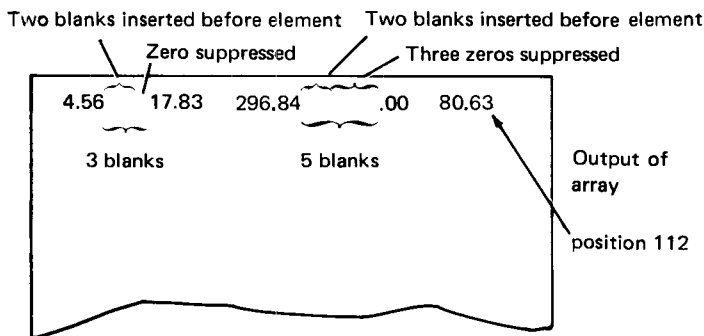

Figure 9-12. Output of an Entire Array With Edit Codes



### Accumulating Groups of Totals

As you have seen, arrays can be used to accumulate a total. In a previous example, elements containing daily sales were added to obtain monthly totals, which were stored in the MONTH array.

To carry this concept further, one of the most common uses of arrays is accumulating more than one group of totals. Such a procedure is called *rolling of totals*, since one total is used to obtain a greater total, which is then used to calculate an even larger total, and so on. Each total is *rolled into* or accumulated into the next total.

Figure 9-15 shows the organization of the Nelson Company. The company's two regions are each divided into three branches, which are in turn made up of two to six stores each.

Company sales data is recorded on cards as shown in Figure 9-16. For each store there is a separate record providing the 12 sales amounts for each month of the year. The sales records are organized such that stores are grouped within a branch and branches grouped within a region. Three one-position fields on each record identify it with a particular store, a particular branch, and a particular region.

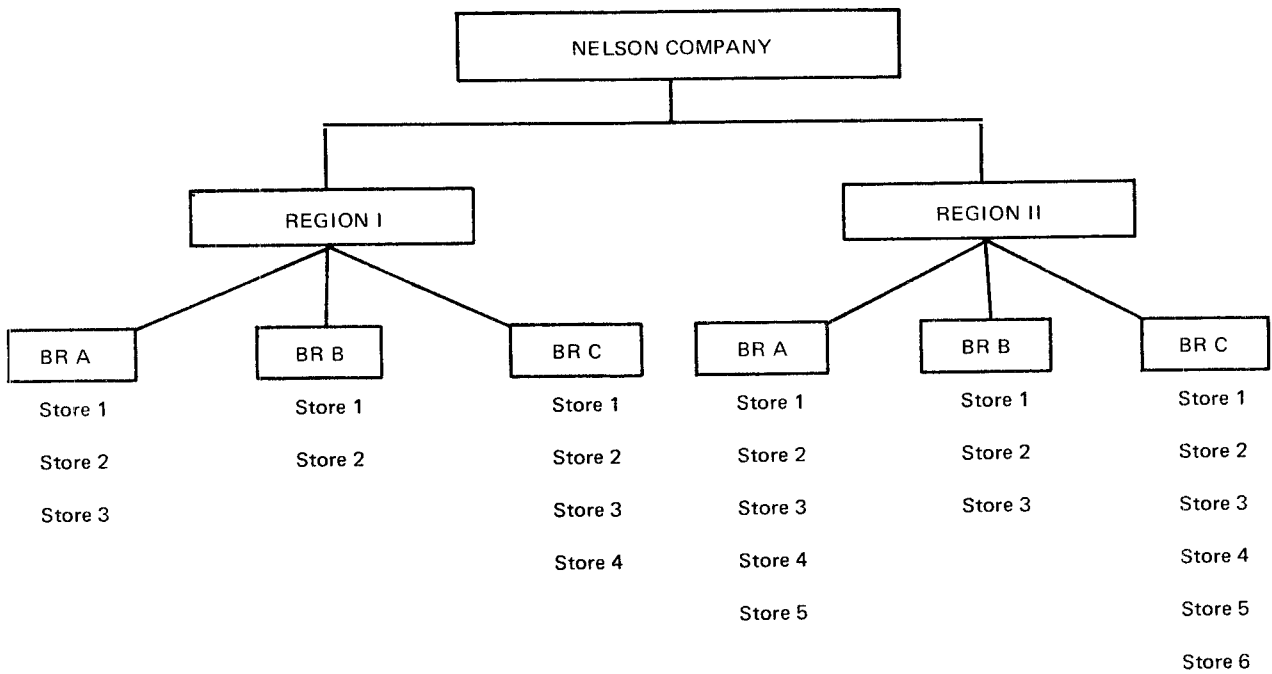

Figure 9-15. Company Organization by Groups

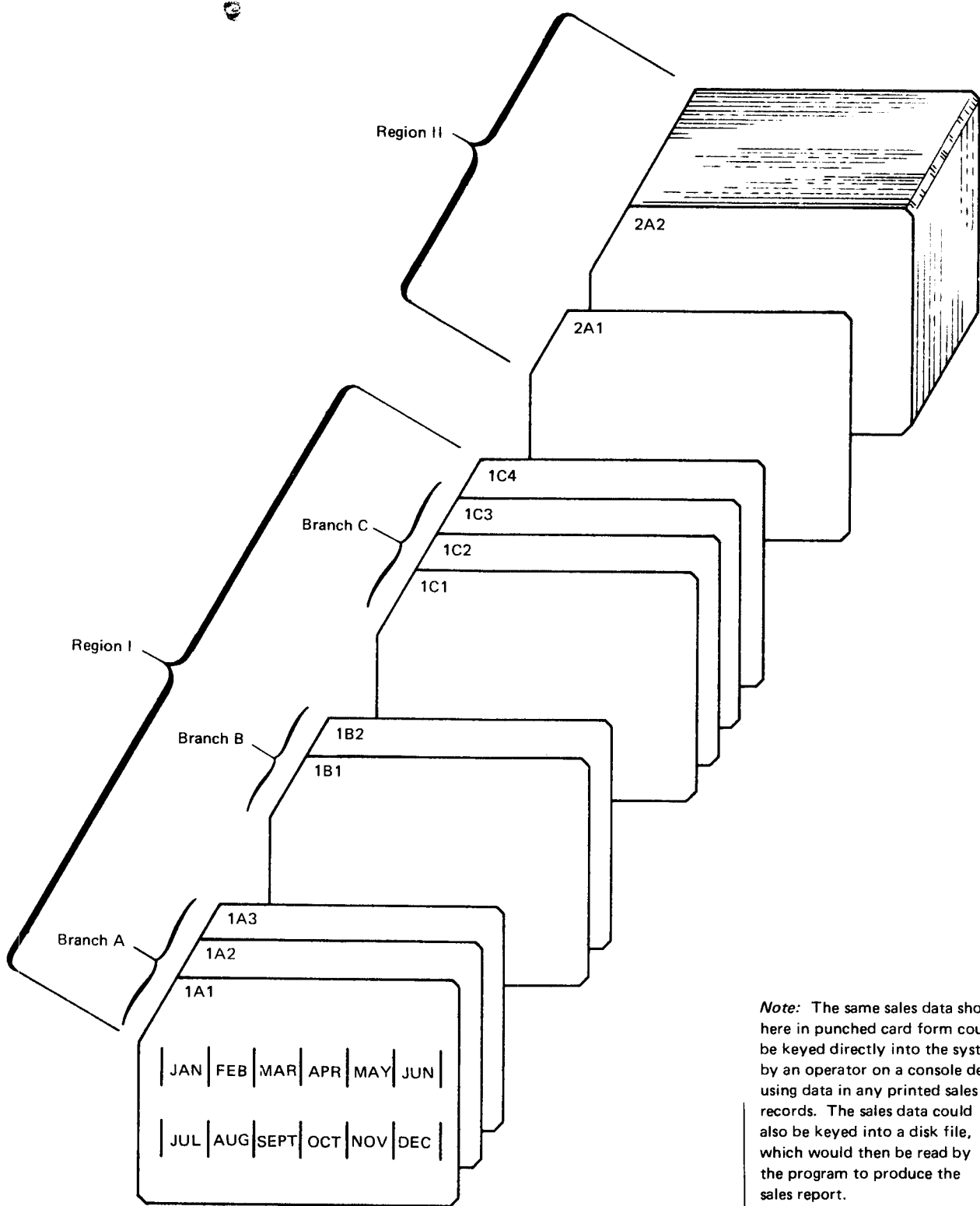

Figure 9-16. Sales Records Organized by Groups Within Groups

SALES REPORT

	JAN	FEB	MAR	APRIL	MAY	JUNE	JULY	AUG	SEPT	OCT	NOV	DEC
STORE	---	---	---	---	---	---	---	---	---	---	---	---
STORE	---	---	---	---	---	---	---	---	---	---	---	---
STORE	---	---	---	---	---	---	---	---	---	---	---	---
BRANCH A TOTAL	---	---	---	---	---	---	---	---	---	---	---	---
STORE	---	---	---	---	---	---	---	---	---	---	---	---
STORE	---	---	---	---	---	---	---	---	---	---	---	---
BRANCH B TOTAL	---	---	---	---	---	---	---	---	---	---	---	---
STORE	---	---	---	---	---	---	---	---	---	---	---	---
STORE	---	---	---	---	---	---	---	---	---	---	---	---
STORE	---	---	---	---	---	---	---	---	---	---	---	---
STORE	---	---	---	---	---	---	---	---	---	---	---	---
BRANCH C TOTAL	---	---	---	---	---	---	---	---	---	---	---	---
REGION I TOTAL	---	---	---	---	---	---	---	---	---	---	---	---
STORE	---	---	---	---	---	---	---	---	---	---	---	---
STORE	---	---	---	---	---	---	---	---	---	---	---	---
STORE	---	---	---	---	---	---	---	---	---	---	---	---
STORE	---	---	---	---	---	---	---	---	---	---	---	---
STORE	---	---	---	---	---	---	---	---	---	---	---	---
BRANCH A TOTAL	---	---	---	---	---	---	---	---	---	---	---	---
STORE	---	---	---	---	---	---	---	---	---	---	---	---
STORE	---	---	---	---	---	---	---	---	---	---	---	---
STORE	---	---	---	---	---	---	---	---	---	---	---	---
BRANCH B TOTAL	---	---	---	---	---	---	---	---	---	---	---	---
STORE	---	---	---	---	---	---	---	---	---	---	---	---
STORE	---	---	---	---	---	---	---	---	---	---	---	---
STORE	---	---	---	---	---	---	---	---	---	---	---	---
STORE	---	---	---	---	---	---	---	---	---	---	---	---
STORE	---	---	---	---	---	---	---	---	---	---	---	---
STORE	---	---	---	---	---	---	---	---	---	---	---	---
BRANCH C TOTAL	---	---	---	---	---	---	---	---	---	---	---	---
REGION II TOTAL	---	---	---	---	---	---	---	---	---	---	---	---
COMPANY TOTAL	---	---	---	---	---	---	---	---	---	---	---	---

Figure 9-17. Sales Report by Groups Within Groups

A sales report must be produced showing the monthly sales for each store, for each branch, for all branches within a region, and for both regions (the total monthly sales of the entire company). The report, a series of accumulated totals, should look like the one in Figure 9-17.

To produce the report, four arrays of 12 elements each should be set up, as shown in Figure 9-18. The first array, STR, will be used to hold the 12 sales amounts entered from the sales records. The other three arrays will be used to accumulate the necessary totals for each branch, each region, and the entire company.

In general, this program should accumulate store totals into the BRNCH array, branch totals into the REG array, and

region totals into the COMP array. Thus, the specifications must perform two functions:

- Add all elements of one array to all elements of another array.
- Print all elements of each array.

To have the program produce the correct totals, you must specify that one array is to be added to another array and printed. To do this, the two fields which identify a record with a particular branch and region should be specified as control fields. A change in the branch (or region) control fields will cause a control break, indicating the records for all stores in a particular branch (or region) have been processed.

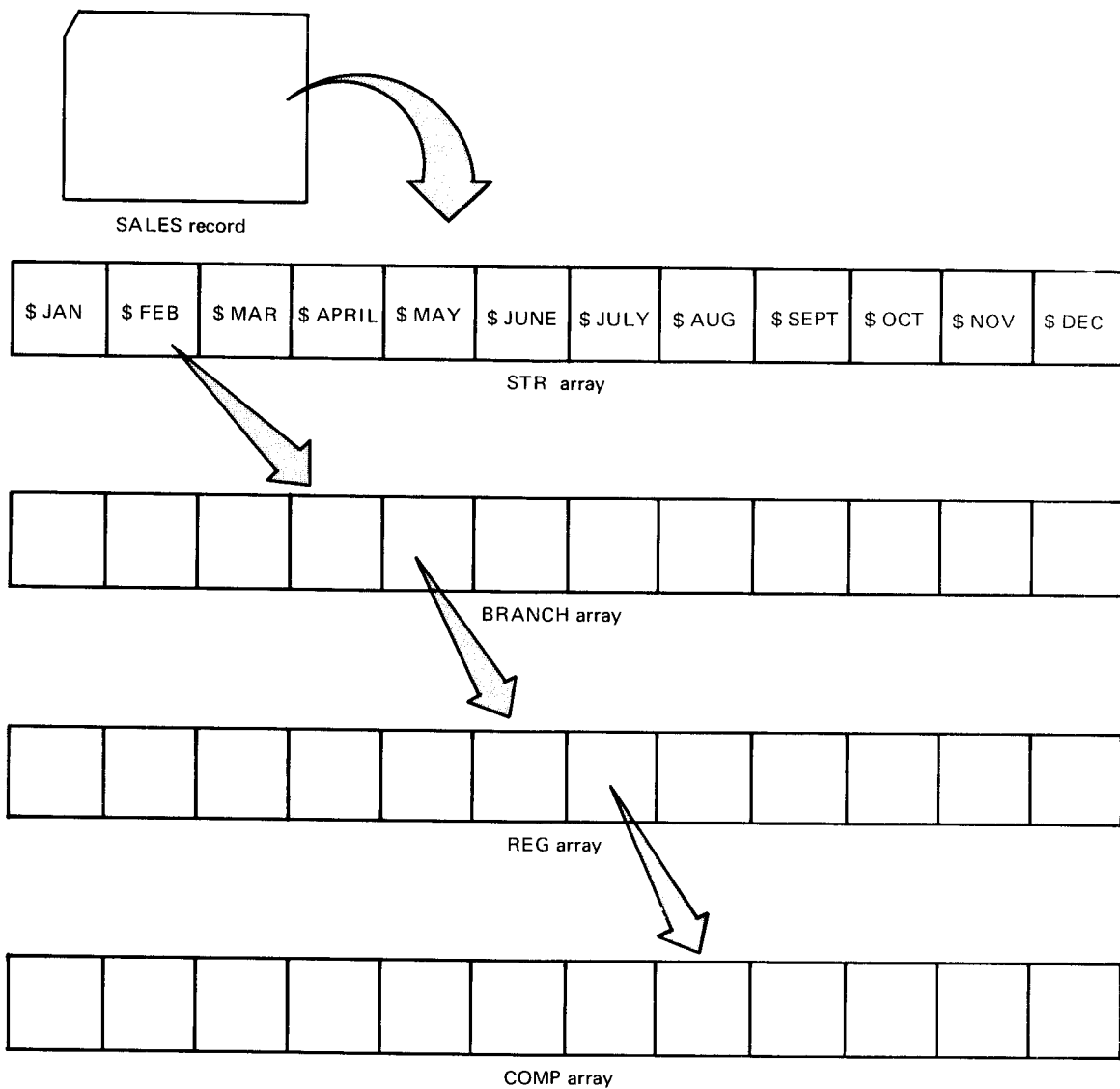

Figure 9-18. Four Arrays for Group Totals



The same procedure is followed for all store records in region II. During every program cycle, the store totals are printed and accumulated to form a branch total; when L1 is on, the branch total is printed and accumulated into a region total.

When the end of file is reached, the LR indicator is turned on. Automatically, all control level indicators assigned (L1 and L2) are also turned on. Therefore, after the last store record has been printed and the store totals added to BRNCH (Figure 9-20, insert A, line 01), any specifications conditioned by L1, L2, or LR are performed. In other words, the totals for the last branch are added to REG (Figure 9-20, insert A); then the region totals are added to COMP. Following the calculations, three sets of totals are printed; totals for the last branch (Figure 9-20, insert B, lines 03-01); then the region II totals; and, finally, the company totals.

## REFERENCING INDIVIDUAL ELEMENTS OF AN ARRAY

In addition to referencing all elements of an array, you can use an individual array element in calculations or output. Suppose you have an array with each element containing the quantity in stock of a particular part manufactured by your company. Element 1 contains the quantity in stock for part #1, element 2 for part #2, and so on. When a shipment of ordered parts is received, the quantity in stock must be updated to reflect the current inventory. This means you should reference (add to) only particular elements of the array.

IBM International Business Machine Corporation			RPG CALCULATION SPECIFICATIONS			Form GX21-0093 Printed in U.S.A.																				
Program		Punching Instruction		Graphic		Card Electro Number																				
Programmer		Date		Punch		Page 1 2 of																				
						Program Identification 75 76 77 78 79 80																				
Line	Form Type	Indicators														Factor 1		Operation	Factor 2		Result Field		Resulting Indicators			Comments
		Control Level (LD, L1, L2, L3, L4, L5, L6, L7, L8, L9, L10, L11, L12, L13, L14, L15, L16, L17)		And		And		Not		Not		Not		Not		Not			Name		Length		Arithmetic			
0 1	C															BRNCH		ADD	STR		BRNCH		Plus Minus Zero			ACCUM BRNCH TOT
0 2	C	L1														REG		ADD	BRNCH		REG		Compare			ACCUM REG TOTAL
0 3	C	L2														COMP		ADD	REG		COMP		1 > 2   1 < 2   1 = 2			ACCUM COMP TOTL
0 4	C																						Lookup (Factor 2) is			
																							High Low Equal			

IBM International Business Machine Corporation			RPG OUTPUT SPECIFICATIONS			Form GX21-0090 U/M 050* Printed in U.S.A.													
Program		Punching Instruction		Graphic		Card Electro Number													
Programmer		Date		Punch		Page 1 2 of													
						Program Identification 75 76 77 78 79 80													
Line	Form Type	Filename	Space				Output Indicators						Field Name		End Position in Output Record		Constant or Edit Word		
			Before		After		And		And		And		And		And		Commas		
0 1	O	REPORT	D								STR		3 122		Yes Yes 1 A J X = Remove Plus Sign				
0 2	O										L1				No No 2 B K Y = Date				
0 3	O		T 23								BRNCH		3B 122		No Yes 3 C L Z = Zero				
0 4	O										L2				No No 4 D M Suppress				
0 5	O		T 33								REG		3B 122						
0 6	O										LR								
0 7	O										COMP		3 122						
0 8	O																		

Figure 9-20. Accumulation and Output of Group Totals Using Arrays



## Indexing an Array

As you learned, if a calculation or output specification contains an array name alone, that specification is automatically performed for every element of the array. To reference only a single element of an array, you must identify that element for the RPG II program. This is done by placing a comma after the array name, followed by an index which points to the particular element (Figure 9-21). This *index* can be either the actual number of the element to be referenced or the name of a field containing the number of the element to be used.

Recall *Defining an Array*. The name used to refer to an array cannot exceed six characters in length. When referencing individual fields, both the array name and an index are necessary to refer to the data. Therefore, usually the array name, plus the comma, plus the index cannot exceed six characters. The name used to refer to an individual array element must be one to six characters long unless the name (with index) used to refer to an individual array element is specified *only* as Factor 1 or Factor 2 on the Calculation sheet. In this case, the array name plus comma plus index may be as long as ten characters. However, the array name portion of the reference still cannot exceed six characters.

Figure 9-21, line 01, shows a valid reference to the ninth element of an array named ARY1. However, if the array contains ten or more elements, some of which may have to be referenced, the name of this array would have to be shortened to provide enough positions for the index (Figure 9-21, line 04). The limit of six characters applies even if the name of a field is used as an index. As line 07 shows,

if an index field IFLD is specified, only one character (B) can be used as the name of the array because the indexed name is specified under Result Field. However, COM, INDEX on line 07 is valid, even though longer than six characters, because it is specified only under factor columns.

### Specifying an Index Which Does Not Change

If you know exactly which element is to be used in a calculation or output operation and the specification is to reference the same element in every program cycle, you may use a constant as the index. Assume a 7-element array (SLS) is defined to contain a salesman's six daily commission amounts and his total commission for the week. The six daily amounts from one of the salesman's input records are read into elements 1-6 of the array. The seventh field on the input record contains zeros and is read into element 7 of the array (Figure 9-22, insert A).

The array elements are defined as 5-digit numbers with two decimal positions. Once the data is in the array, the XFOOT calculation operation is performed to add all elements of the array and place the total in the seventh element (Figure 9-22, insert B). The weekly total for every salesman is always stored in the seventh element. Therefore, the actual number 7 can be specified as the index. In addition, a \$25 bonus is to be added to a salesman's total if his weekly commission exceeds \$175 (Figure 9-22, insert C). Thus, in every program cycle, element 7 must first be compared to \$175 to determine if the bonus is to be added to the contents of element 7.

IBM International Business Machine Corporation		RPG CALCULATION SPECIFICATIONS		Form GK21-9083 Printed in U.S.A.					
Program		Punching Instructions	Graphic	Card Electro Number					
Programmer		Date	Punch	Page 1 of 2	Program Identification 75 76 77 78 79 80				
Line	Form Type	Control Level (LD, LD, LR, SR, AN, OR)	Indicators	Factor 1	Operation	Factor 2	Result Field	Resulting Indicators	Comments
			And And				Name Length	Arithmetic Plus Minus Zero Compare > < = 2 1 < 2 1 = 2 Lookup Factor 2 is High Low Equal	
01	C			ARY1,9	ADD	10	ARY1,9		Actual number used as index.
02	C*								
03	C*								
04	C			AR1,12	ADD	10	AR1,12		Name of field used to contain index value.
05	C*								
06	C*								
07	C			COM,INDEX	MULT	25	B,IFLD		
08	C								

Figure 9-21. Referencing a Particular Element of an Array

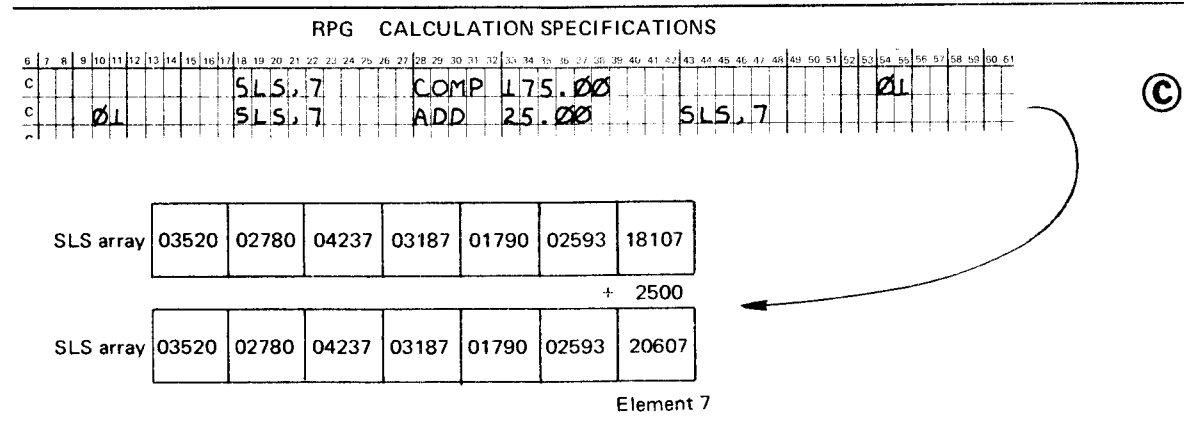
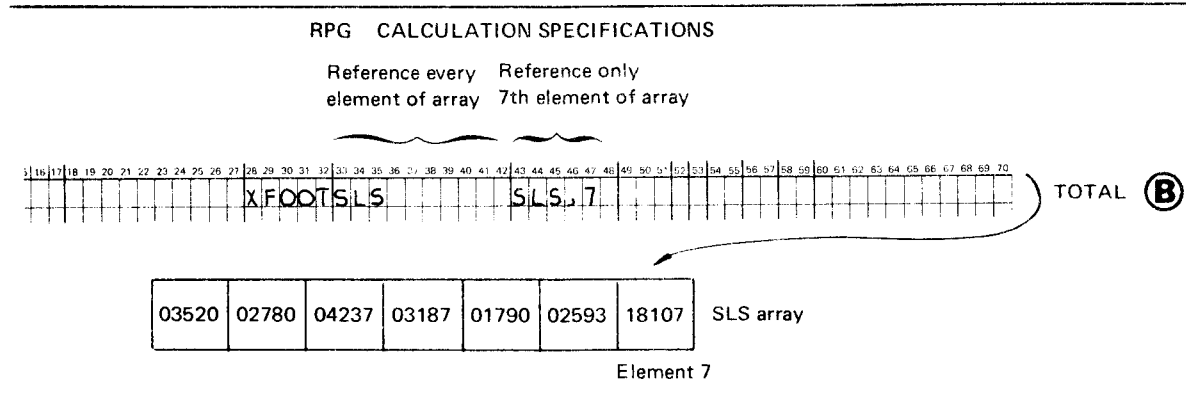
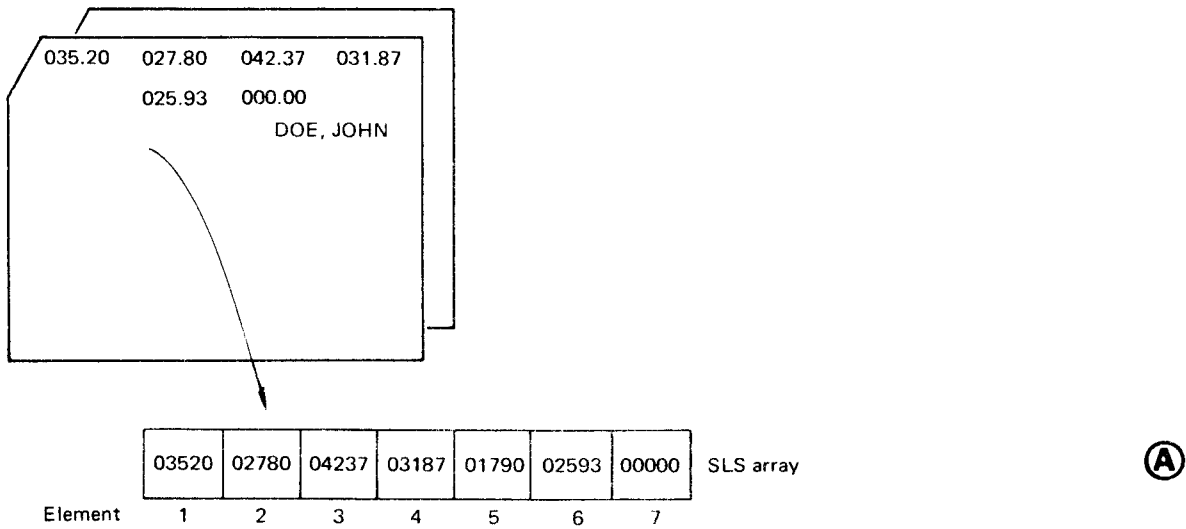

Figure 9-22. Specifying a Number as an Index



IBM International Business Machine Corporation																				RPG OUTPUT SPECIFICATIONS					GX21 9090 U/M 050* Printed in U.S.A.																																																																																																																						
Program					Punching Instruction					Graphic					Card Electro Number					Page 1 of 2		Program Identification 75 76 77 78 79 80																																																																																																																									
Programmer					Date					Punch																																																																																																																																					
O		Line		Filename		Type (H/D/E)		Space		Skip		Output Indicators		Field Name		End Position in Output Record		Constant or Edit Word		<table border="1" style="font-size: x-small;"> <tr><td>Commas</td><td>Zero Balances to Print</td><td>No Sign</td><td>CR</td><td>-</td><td>X</td></tr> <tr><td>Yes</td><td>Yes</td><td>1</td><td>A</td><td>J</td><td>Remove Plus Sign</td></tr> <tr><td>Yes</td><td>No</td><td>2</td><td>B</td><td>K</td><td>Date</td></tr> <tr><td>No</td><td>Yes</td><td>3</td><td>C</td><td>L</td><td>Field Edit</td></tr> <tr><td>No</td><td>No</td><td>4</td><td>D</td><td>M</td><td>Zero Suppress</td></tr> </table>					Commas	Zero Balances to Print	No Sign	CR	-	X	Yes	Yes	1	A	J	Remove Plus Sign	Yes	No	2	B	K	Date	No	Yes	3	C	L	Field Edit	No	No	4	D	M	Zero Suppress																																																																																									
Commas	Zero Balances to Print	No Sign	CR	-	X																																																																																																																																										
Yes	Yes	1	A	J	Remove Plus Sign																																																																																																																																										
Yes	No	2	B	K	Date																																																																																																																																										
No	Yes	3	C	L	Field Edit																																																																																																																																										
No	No	4	D	M	Zero Suppress																																																																																																																																										
		Form Type				Shaker #		Before		After		And		And		B/A/C/T/S/R		P/B/L/R																																																																																																																													
						O H A D		Before		After		Not		Not		Not																																																																																																																															
						O H A D		Before		After		Not		Not		Not																																																																																																																															
3		4		5		6		7		8		9		10		11		12		13		14		15		16		17		18		19		20		21		22		23		24		25		26		27		28		29		30		31		32		33		34		35		36		37		38		39		40		41		42		43		44		45		46		47		48		49		50		51		52		53		54		55		56		57		58		59		60		61		62		63		64		65		66		67		68		69		70		71		72		73		74	
0		1		O		REPORT		D						'AUTO		SLS, 7 3 23		Referencing the same element by using actual number as index																																																																																																																													
0		2		O																																																																																																																																											
0		3		O																																																																																																																																											
0		4		O																																																																																																																																											
0		5		O																																																																																																																																											
0		6		O		CARDS		D						STK, NM3		32		Referencing different elements by using a field as the index																																																																																																																													
0		7		O																																																																																																																																											
0		8		O																																																																																																																																											

Figure 9-24. Output of Individual Array Elements

**Referencing Only Part of a Field**

When a field is referenced in a specification, all characters within that field are used in the calculation or output. However, you may wish to reference only some of the data stored in a field. For example, consider the case during address printing where the zip code is within the same field as the city and state on an input record but must be printed on a separate line on the output record (Figure 9-25).

The indexing capability of arrays can be used to enable you to reference specific characters from an input field. This is accomplished by setting up two arrays; one to contain the entire field of data and one to hold only the specific characters you want to reference.

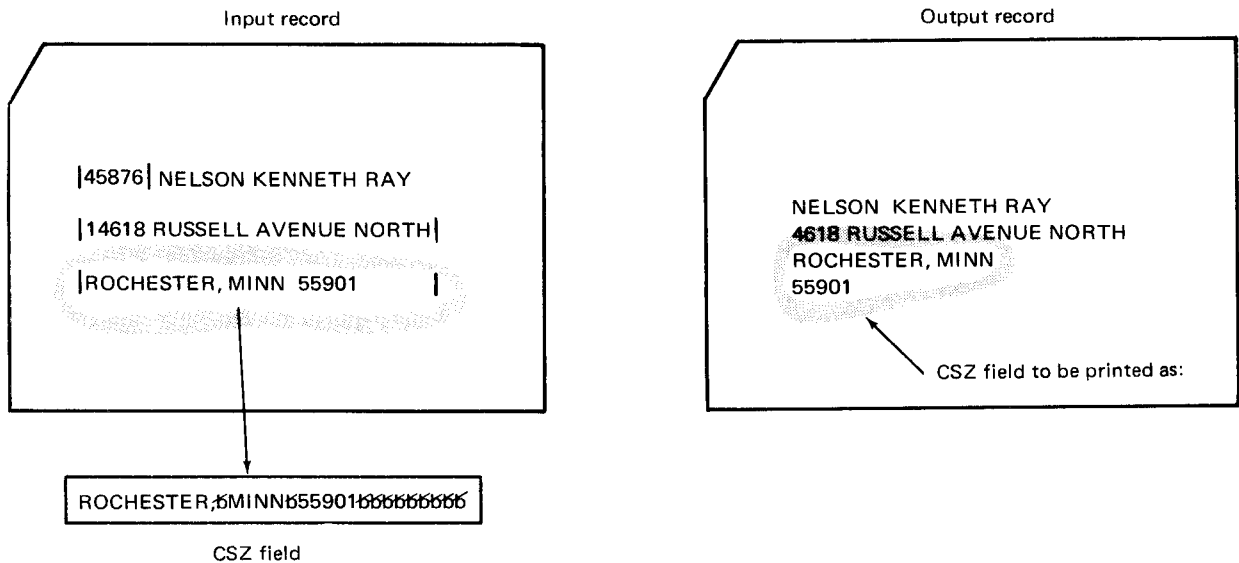

Figure 9-25. Referencing Parts of a Field Separately

First, the entire field from which you wish to use data is stored in an array of the same name as shown in Figure 9-26. (See *Loading Arrays, Storing Input Data into Execution Time Arrays* later in this chapter for an explanation of this method of loading an array.) This array is previously defined as containing as many one-byte elements as there are characters in the field to be referenced. Thus, each character of the one field is actually stored in a separate element of the array. The array elements can then be referenced one at a time (using an index) until an element containing a specific character is located. This process of checking the elements of an array for particular data is referred to as *field scanning*.

After scanning the elements and locating a specific character, you can then move that character and any characters (elements) on either side of it to a smaller array. This ar-

ray will then contain the portion of the original input field which you wish to reference separately in calculations or output.

For an address printing program, let's assume the input records are defined as shown in Figure 9-27. The CSZ field contains the city/state and zip code. Although names of the city and state may vary in length, the zip code is always five digits long. Any righthand, unused positions of the CSZ field will contain blanks.

The two arrays for this program are defined with the extension specifications in Figure 9-28. CSZ is set up to contain 30 elements, one for each character of the CSZ field from the input record. The five elements of the ZIP array will be used to contain the zip code portion of the CSZ field.

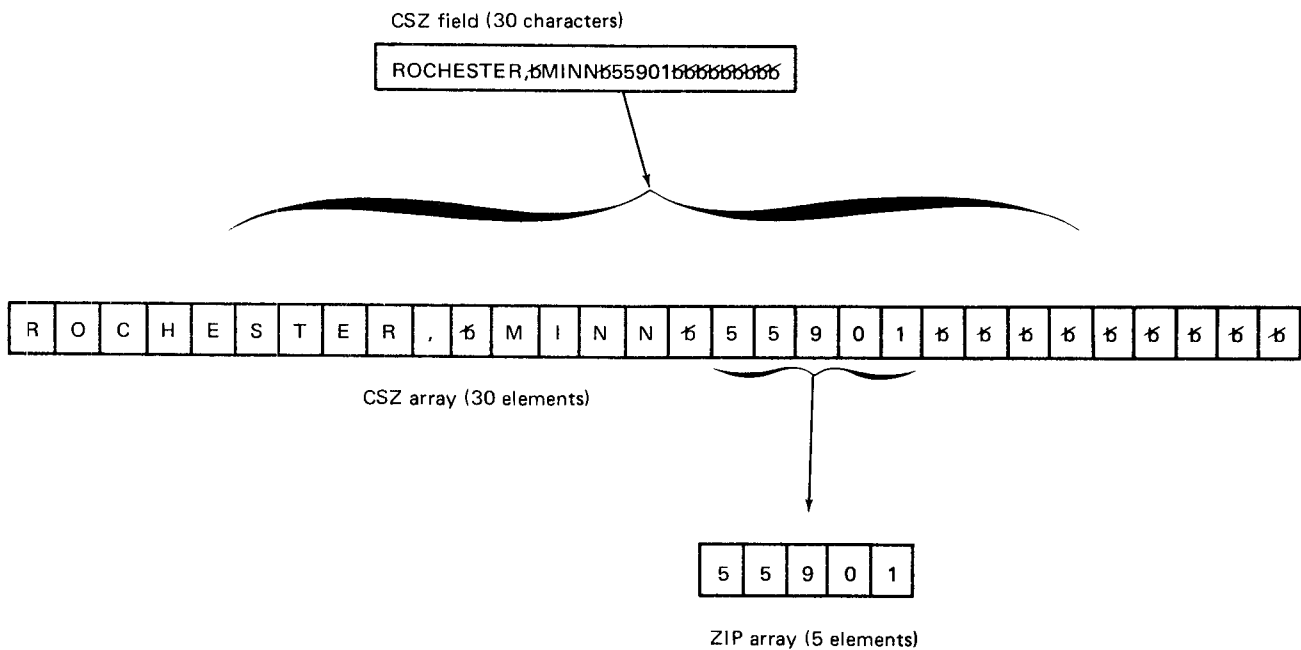

Figure 9-26. Isolating Part of a Field

**IBM** International Business Machine Corporation

**RPG INPUT SPECIFICATIONS**

GX21-9084 U/M 050\*  
Printed in U.S.A.

Program		Punching Instruction	Graphic	Card Electro Number				Page 1 2 of	Program Identification	75 76 77 78 79 80
Programmer		Date	Punch							

Line	Form Type	Filename	Sequence Number (I/N) Option (O)	Record Identification Codes									Field Location		Field Name	Control Level (L1-L9) Matching Fields or Chaining Fields	Field Record Relation	Field Indicators														
				1			2			3			From	To				Plus	Minus	Zero or Blank												
				Position	Not (N) C/Z/D Character	Position	Not (N) C/Z/D Character	Position	Not (N) C/Z/D Character	Position	Not (N) C/Z/D Character	Position	Not (N) C/Z/D Character	Stagger Select P/B/L/R	Decimal Positions																	
0 1	I	INPUT	AA 0L												1	5																
0 2	I														6	35																
0 3	I																															
0 4	I														36	65																
0 5	I														66	95																
0 6	I	* CSZ FIELD CONTAINS CITY-STATE-ZIPCODE																														
0 7	I																															

ROCHESTER, MINNB55901BBBBBBBBBB

Figure 9-27. Defining a Field to be Scanned

CSZ field

**IBM** International Business Machine Corporation

**RPG EXTENSION AND LINE COUNTER SPECIFICATIONS**

Form X21-9091  
Printed in U.S.A.

Program		Punching Instruction	Graphic	Card Electro Number				Page 1 2 of	Program Identification	75 76 77 78 79 80
Programmer		Date	Punch							

**Extension Specifications**

Line	Form Type	Record Sequence of the Chaining File		To Filename	Table or Array Name	Number of Entries Per Record	Number of Entries Per Table or Array	Length of Entry	P/B/L/R	Decimal Positions Sequence (A/D)	Table or Array Name (Alternating Format)	Length of Entry	P/B/L/R	Decimal Positions Sequence (A/D)	Comments
		From Filename	Number of the Chaining Field												
0 1	E				CSZ		37	1							FOR ENTIRE FIELD
0 2	E				ZIP		5	1							FOR ZIP CODE ONLY

Figure 9-28. Defining Arrays for Field Scanning

To locate the zip code in the CSZ array, the elements must be scanned one at a time, beginning with the last (rightmost) element of the array. Thus, the index field (C) for referencing the individual fields of CSZ is initially set up in the Calculation sheet to contain the value 30 (Figure 9-29, line 01). When the last (rightmost) character of the zip code is located, it should be moved to the rightmost (fifth) element of the ZIP array. Therefore, a 5 is initially set up in the index field (Z) which will reference a particular field of ZIP (Figure 9-29, line 02).

With the index fields set up, the program can begin scanning CSZ for the zip code. The elements of CSZ are checked, from right to left, until the first nonblank character is located. As line 04 shows, a character is compared to a blank. If it is blank, the index value is decreased (line 05) so the next character to the left can be compared to a blank. When one of the characters checked is not a blank (indicator 20 off), the last character of the zip code has been located. This ends the field scanning.

The program can now proceed to perform the next group of calculations which move the located character to the rightmost position of the ZIP array (line 09). The character in the CSZ array which was moved to the ZIP array is now made blank (line 10) so the city and state line can be printed without the zip code. The index values for both arrays are decreased by 1, so the next zip code character (to the left of the last one moved) can be moved from CSZ to the next portion in the ZIP array. When the value of Z becomes 0 (indicator 21 is on), all five characters of the zip code have been moved to the ZIP array and made blank in the CSZ array.

After calculations, the output specifications in Figure 9-30 cause the name and address to be printed. The NAME and STREET fields are printed exactly as they appear on the input record. City and state, on the other hand, are printed from the CSZ array rather than the input field, because the zip code has been blanked out. The zip code, which was moved to the ZIP array, is then printed alone on the next output line.

IBM International Business Machine Corporation						RPG CALCULATION SPECIFICATIONS																				Form GX21-9093 Printed in U.S.A.			
Program			Punching Instruction			Graphic									Card Electro Number			Page 1 2 of		Program Identification 75 76 77 78 79 80									
Programmer			Date			Punch																							
Line	C	Form Type	Control Level (L0-L9, LR, SR, AN/OR)	Indicators											Factor 1	Operation	Factor 2	Result Field			Resulting Indicators			Comments					
				And	And	Not	Not	Not	Not	Not	Name	Length	Decimal Positions	High				Low	Equal	Plus	Minus	Zero							
01	C															Z-ADD30		C	20								INDX FOR CSZ AR		
02	C															Z-ADD5		Z	10									INDX FOR ZIP AR	
03	C														FINZIP	TAG													
04	C														CSZ,C	COMP ' '												20 IS CHAR A BLANK	
05	C														C	SUB L		C										YES-DECRS INDX	
06	C															GOTO FINZIP												CHCK NXT CHARAC	
07	C	**																											
08	C														MOVZIP	TAG													
09	C															MOVE CSZ,C		ZIP,Z										MOV 1 CHAR ZPCD	
10	C															MOVE ' '		CSZ,C										BLANK OUT ZIPCD	
11	C														C	SUB L		C										DECRSE INDEX OF	
12	C														Z	SUB L		Z										21 BOTH ARRAYS	
13	C														N2L	GOTO MOVZIP												TO MVE NXT CHAR	
14	C	*																											
15	C	*																											
16	C	*																										BLANKING OUT ON LINE 10 IS NECESSARY SO WHEN ALL ARRAY IS	
17	C	*																										OUTPUT, CITY AND STATE ARE PRINTED WITHOUT ZIPCODE.	
18	C																												

Figure 9-29. Field Scanning

IBM		RPG OUTPUT SPECIFICATIONS				GX21 9090 U/M 050* Printed in U.S.A.	
Program		Punching Instruction		Graphic		Card Electro Number	
Programmer		Date		Punch		Page 1 2 of	
						Program Identification 75 76 77 78 79 80	

Line	Form Type	Filename	Type (H/D/T/E)		Space		Skip		Output Indicators		Field Name	End Position in Output Record	Edit Codes	P/B/L/R	Constant or Edit Word
			Before	After	Before	After	And	And	Not	Not					
01	O	BILLS	D	L					Ø1						
02	O										NAME	30			
03	O		D	L					Ø1		STREET	30			
04	O		D	L					Ø1		CSZ	30			
05	O		D	L					Ø1		ZIP	5			

Only city and state will be printed since zip code blanked out.

Only zip code will be printed.

Figure 9-30. Output of Part of a Field

### LOKUP OF AN ARRAY

#### Searching an Array for a Particular Element

An array can be searched to determine if a particular element of data is stored in the array. Actually, the array lookup is coded and performed in almost the same way as a single table lookup. As the Calculation sheet in Figure 9-31 shows, you specify:

1. The search word to be used.
2. The LOKUP operation code.
3. The array to be searched.
4. The condition which must be satisfied.
5. The resulting indicator which turns on if the condition is met.

IBM		RPG CALCULATION SPECIFICATIONS				Form GX21 9093 Printed in U.S.A.	
Program		Punching Instruction		Graphic		Card Electro Number	
Programmer		Date		Punch		Page 1 2 of	
						Program Identification 75 76 77 78 79 80	

Line	Form Type	Control Level (L0, L9, L1, SR, AN, OR)	Indicators		Factor 1	Operation	Factor 2	Result Field		Resulting Indicators	Comments
			And	And				Name	Length		
01	C				QTY	LOKUP	PARAL			16	

Actual search word or field containing search word

Name of array to be searched

Condition which satisfies search and which resulting indicator is turned on

Figure 9-31. Searching an Array for a Particular Element



The array lookup continues, one element at a time, until the search condition is satisfied or the end of the array is reached, whichever occurs first. As is the case for table lookups, array elements must be in sequence (A or D) if searching for either a low or high condition. Additional coding is necessary if searching an out-of-sequence array for either high or low. (See *Searching an Array for More Than One Element and Output During an Array Search.*)

Although array and table searches are similar, there is an important difference you must be aware of. Remember, the array lookup is similar to a single-table lookup, not a two-table lookup. Only one array is specified in the lookup operation. Any element which is referenced as the result of a successful search can only be from the array actually searched. In other words, the array can not be searched to make an element from another array available, as is the case when two related tables are used in a lookup operation. For this reason, no result field may be specified in an array lookup operation.

**Starting the Search at a Particular Element**

Another very important difference between tables and arrays concerns where the search can begin. In a table search, only the name of the table to be searched can be specified as Factor 2 of the lookup operation. As a result, a table search always begins at the first table element. Likewise, if only an array name is specified as Factor 2 of a lookup operation, the search automatically begins at the first element of the named array.

With arrays, however, you also have the capability of beginning an array search at any element you specify. Under Factor 2, you specify the array name, followed by a comma and an index. The index, whether an actual number or the name of a field containing a number, points to the array element where the search is to begin (Figure 9-32).

In a large array where you know that the value you are searching for is not in a particular section of the array, search time can be greatly decreased by beginning the lookup at a particular element. Suppose you have a 300-element array name ARY containing the values 001 through 300 in ascending sequence. To locate a value of 047, only 47 elements would have to be checked before the search condition was satisfied. However, to locate the value 289, 289 elements would have to be checked, *if* the search began at the first array element.

Now, divide the array into three parts of 100 elements each:

- Elements 1-100: values 001-100.
- Elements 101-200: values 101-200.
- Elements 201-300: values 201-300.

C		Indicators		Factor 1	Operation	Factor 2	Result Field		Resulting Indicators			Comments
Line	Form Type	And	And			Name	Length	Decimal Positions	Arithmetic	Compare	Lookup(Factor 2) is	
3	4	5	6	7	8	9	10	11	12	13	14	
15	16	17	18	19	20	21	22	23	24	25	26	
0-1	C			SRCHWD	LOKUPARY	23					26	
0-2	C	XOR										
0-3	C			SRCHWD	LOKUPARY	IX					26	
0-4	C											
0-5	C											
0-6	C											

Figure 9-32. Starting an Array Search at a Particular Element

For any value of less than 101, the first third of the array is searched, beginning at element 1. For values greater than 100, but less than 201, the second third of the array is searched, beginning at element 101. Likewise, a search is started at element 201 to locate any value greater than 200. In any case, no more than 100 elements have to be checked to satisfy the search condition.

For this example, the number of the array element at which the search is to begin will vary, depending on the value being searched for. Figure 9-33 shows that three LOKUP's have been coded. Only one of the lookup operations is performed for a particular value.

To determine which LOKUP (line 04, 05, or 06) is performed, you must first determine in which part of the array the value is located. The first COMP (compare) operation (line 02) checks for a value in the first 100 elements. If the value is less than 101, indicating the first one third of the array, indicator 33 is set on. If 33 is on, the LOKUP beginning at element 1 is performed (line 04). However, if the value is not in the first third of the array (33 off), another compare (line 03) is necessary to determine if the value is in the second third of the array (indicator 44 set on). Thus, the LOKUP beginning at element 101 (line 05) is performed with indicator 44 on. If neither indicator (33 or 44) was set on, the value must be in the last third of the array, if it is in the array at all. Therefore, with both 33 and 44 off, the LOKUP beginning at element 201 is performed.

For the first LOKUP (line 04), it is not necessary to actually specify the numeric value 1 as the index, in the same manner as 101 is specified for the second LOKUP. When no index is specified with the array name, the search automatically begins at the first field, as if the index were 1.

*Note:* Setting off indicator 44 (line 01) prevents an error in the lookup function. What would happen if the SETOF operation was not used and indicator 44 was set on in the first cycle and 33 in the second cycle? In that case, 44 would not be set off in the second cycle because the N33 condition would not be satisfied in line 03. Thus, both lines 04 and 05 would be executed. The LOKUP operation in line 04 would be successful and indicator 66 would turn on. The LOKUP operation in line 05 would not be successful and 66 would be turned off. Thus, a not-found condition would result even though the LOKUP was successful.

If the value of the index changes, as in this case, you can use an index field to contain the number of the array field, rather than using the actual number. In this way, it is necessary to code only one LOKUP. Of course, you must place the appropriate number in the index field every time before the lookup operation is performed. Thus an index field will not always reduce the number of specifications required.

C		RPG CALCULATION SPECIFICATIONS																Form GX21-9093 Printed in U.S.A.	
IBM International Business Machine Corporation		Program		Punching Instruction		Graphic Punch		Card Electro Number		Page 1 2 of		Program Identification		75 76 77 78 79 80					
Line	Form Type Control Level (LG-LR, LR, SR, AN/OR)	Indicators						Factor 1	Operation	Factor 2	Result Field		Resulting Indicators		Comments				
		And	And	Not	Not	Not			Name	Length	Decimal Positions	Plus	Minus	Zero					
											Half Adjust (H)	1 > 2	1 < 2	1 = 2					
												Lookup (Factor 2) is	High	Low		Equal			
01	C								SETOF						44				
02	C							VALUE	COMP 101						33	FIRST THIRD?			
03	C	N33						VALUE	COMP 201						44	SECOND THIRD?			
04	C	33						VALUE	LOKUPARY							66START AT FLD #1			
05	C	44						VALUE	LOKUPARY, 101							66START FLD #101			
06	C	N33N44						VALUE	LOKUPARY, 201							66START FLD #201			
07	C																		
08	C																		

Figure 9-33. LOKUP with an Actual Index

As shown in Figure 9-34, first the compare operations are performed to determine whether the value is in the first, second, or last third of the array. The results of the compare operations determine which number should be zero-added into the index field, IXFLD, before the lookup is performed.

See the previous *Note* for an explanation of the use of the SETOF operation in Figure 9-34 (line 01).

*Determining if a Search Is Successful*

At this point, we should discuss the index field and how its contents are changed as a result of the lookup operation. Before the lookup is performed, you determine the value which is to be placed in the index field. The array search

then begins at the element number specified. The array lookup continues, one element at a time, until the search condition is satisfied or the end of the array has been reached, whichever occurs first. If an index field is specified, the number of the array element first satisfying the search condition is stored in the index field. However, if the end of the array is reached and none of the elements satisfy the search, a 1 is placed in the index field. In any case, if an actual number, not an index field, is specified as the index, the actual index is not changed to reflect the success of the search.

The way in which you determine a successful search is whether the resulting indicator assigned has been turned on or off. Thus, if the resulting indicator is off and an index field had been specified, the index field should contain the value 1, the result of an unsuccessful search. If the first field of an array satisfied the search condition, the index field would also contain the value 1; however, in such a case, the resulting indicator would be on.

IBM		RPG CALCULATION SPECIFICATIONS		Form GX21-9093 Printed in U.S.A.												
Program			Punching Instruction	Graphic	Card Electro Number											
Programmer			Date	Punch												
					Page 1 2 of 75 76 77 78 79 80											
C	Line	Form Type Control Level (L, O, L, S, R, AN, OR)	Indicators			Factor 1	Operation	Factor 2	Result Field		Resulting Indicators			Comments		
			Not	And	And				Name	Length	Arithmetic	Plus	Minus		Zero	
			Not	And	And						Decimal Positions <td>1 &gt; 2</td> <td>1 &lt; 2</td> <td>1 = 2</td> <td></td>	1 > 2	1 < 2	1 = 2		
											Half Adjust (H)	Lookup Factor 2 is	High	Low	Equal	
01	C					VALUE	SETOF					44				
02	C					VALUE	COMP 10L					33				FIRST THIRD?
03	C		N33			VALUE	COMP 20L					44				NO-SECND THIRD?
04	C		33				Z-ADD00L		IXFLD	30						START AT FLD #1
05	C		44				Z-ADD00L		IXFLD							START FLD #10L
06	C		N33N44				Z-ADD20L		IXFLD							START FLD #20L
07	C					VALUE	LOOKUPARY, IXFLD					66				
08	C															

Figure 9-34. LOKUP with an Index Field

### Referencing an Element Which Satisfies a Search

After a successful search, you can use the data from the element which satisfied the condition only if the array name with an index field is specified in the LOKUP specifications. If an index field is specified, the number of the field which satisfied the search is stored in the index field. Therefore, specifying the array name with the index field in a subsequent calculation or output specification refers to the element which satisfied the search.

However, if no index field is available (array name specified alone or with a numeric index), the number of the element cannot be determined and, therefore, the data cannot be referenced. You can only determine if one of the array elements does contain the data for which you searched, according to the on-off status of the resulting indicator.

The ability to reference a data item which satisfies a search is one of the major differences between an array lookup and a table lookup. During a table lookup, when a field is found which satisfies the search, the table name alone refers to the data item which satisfied the search. Following a lookup for an array, specifying the array name alone refers to the entire array, rather than to any particular element. The only way an individual array element can be referenced is by specifying the array name with an index.

Assume you wish to search an array CHG to check for amounts over \$100. If you only want to determine if there are any elements containing a greater amount, the search can be coded as shown in Figure 9-35. If indicator 16 is on, indicating a successful search, you can then print a message stating there is a charge over \$100. Otherwise, if indicator 16 is off, you can print a message stating all charges are under or equal to \$100. With the LOKUP specification shown, however, you would have no way of knowing how many elements or which elements satisfied the search condition.

**RPG CALCULATION SPECIFICATIONS** Form GX21 9093  
Printed in U.S.A.

Program _____						Punching Instruction _____	Graphic _____	Card Electro Number _____		Page 1 2 of _____	Program Identification 75 76 77 78 79 80											
Programmer _____						Date _____		Punch _____														

C	Line	Form Type	Indicators											Factor 1	Operation	Factor 2	Result Field		Resulting Indicators	Comments			
			Control Level (LO, L9, LF, SR, AN/OR)						And	And	Not	Not	Not				Not	Name			Length	Decimal Positions	Half Adjust (H)
			1	2	3	4	5	6															
	1	C												100.00	LOKUPCHG					16			
	2	C																					
	3	C																					

Figure 9-35. Determining Only if a Search Is Successful

If you wish to know which element satisfied the search or, perhaps, how much over \$100 the amount is, the array lookup should be coded with an index field (Figure 9-36). The index field can be preset to contain the value 1, so the search begins at the first element of the array. If the search is satisfied, IX will contain the number of the first element over \$100; and the resulting indicator will be turned on. The contents of IX can then be printed to indicate which element satisfied the search. The actual contents of that element can be printed by specifying the array name with the index field (Figure 9-36, Output sheet).

### Searching An Array for More Than One Element

The previous example points out an important consideration: an array LOKUP operation is completed when the first element is found which satisfies the search condition. If you wish to find all elements which satisfy the condition, you must code additional specifications which cause the program to loop back in calculations to repeat the lookup operation from the point where the last search was successful.

As an example, assume your company manufactures 25 different items, identified by item codes 1-25. A 25-element array QTY (Figure 9-37) is used to keep track of the quantity in stock of each item. The first element contains the quantity of item code 1, the second element contains the quantity of item code 2, and so on.

IBM International Business Machine Corporation																																																																											Form GX21-9093 Printed in U.S.A.
Program			Punching Instruction	Graphic Punch	Card Electro Number	Page 1 of 2	Program Identification 75 76 77 78 79 80																																																																				
Line	Form Type C	Control Level LR, SR, AN/DR	Indicators												Factor 1	Operation	Factor 2	Result Field		Resulting Indicators	Comments																																																						
			And						And									Name	Length			Arithmetic																																																					
			Not	Not	Not	Not	Not	Not	Not	Not	Not	Not	Not	Not									Plus	Minus	Zero	Compare																																																	
3	4	5	6	7	8	9	10	11	12	13	14	15	16	17	18	19	20	21	22	23	24	25	26	27	28	29	30	31	32	33	34	35	36	37	38	39	40	41	42	43	44	45	46	47	48	49	50	51	52	53	54	55	56	57	58	59	60	61	62	63	64	65	66	67	68	69	70	71	72	73	74				
0 1	C															Z-ADDL		IX	30																																																								
0 2	C	*																																																																									
0 3	C	*																																																																									
0 4	C														L00.00	LOKUPCHG,IX			16																																																								

IBM International Business Machine Corporation																																																																											GX21-9096 U/M 050* Printed in U.S.A.
Program			Punching Instruction	Graphic Punch	Card Electro Number	Page 1 of 2	Program Identification 75 76 77 78 79 80																																																																				
Line	Form Type O	Filename	Type (M/D/Z/E)	Space	Skip	Output Indicators												Field Name	Edit Codes B/A/C/T/9/R	Field Position in Output Record	F/B/L/R	Constant or Edit Word																																																					
						And						And										Commas	Zero Balances to Print	No Sign	CR	-	X - Remove Plus Sign																																																
						Before	After	Not	Not	Not	Not	Before	After	Not	Not	Not	Not											Yes	No	Yes	No	Yes	No	Yes	No	Yes	No																																						
3	4	5	6	7	8	9	10	11	12	13	14	15	16	17	18	19	20	21	22	23	24	25	26	27	28	29	30	31	32	33	34	35	36	37	38	39	40	41	42	43	44	45	46	47	48	49	50	51	52	53	54	55	56	57	58	59	60	61	62	63	64	65	66	67	68	69	70	71	72	73	74				
0 1	O	OUTPUT	D																IX																																																								
0 2	O																																																																										
0 3	O																																																																										
0 4	O																																																																										
0 5	O																																																																										

Figure 9-36. Determining Which Array Element Satisfies the Search

QTYARRAY

Array Element

1	2	3	4	5	6	7	8	9	10	11	12	13	14	15	16	17	18	19	20	21	22	23	24	25
047	068	051	023	076	083	105	069	053	117	014	087	032	046	083	106	024	048	071	029	108	067	035	008	075

Below stock level of 25

Figure 9-37. More than One Array Element Which Satisfies the Search Condition

100 items are to be manufactured and added to stock whenever the quantity of an item falls below 25. To determine which items are to be manufactured, every week the QTY array is searched, comparing the array elements with a search word (MFGPT) of 25 from a data card. When a quantity is found to be less than 25 (search condition Low), the item code and quantity in stock are printed.

From Figure 9-37 you can see that four items must be manufactured. The specifications in Figure 9-38 will not locate all of the items with quantities less than 25. The lookup operation shown will locate only the first quantity below 25. If only one data card (containing the search word) is read, the specifications are performed once. As you know, for every data card read, the program cycle is repeated. However, even if several data cards with the same search word

are read, every time the lookup is repeated, the search begins again at element 1 of the array. Therefore, the same array element satisfies the search every time, and the other three quantities are never found.

To locate more than one element satisfying the same search condition, the LOKUP must be repeated within a single program cycle. Not only must the LOKUP be repeated, but the search must begin at the point where the previous search ended. You can repeat the LOKUP using the GOTO and TAG operations, as shown in Figure 9-39. To make sure the repeated search begins where the last search left off, you must specify the array name with an index field in the LOKUP specification. The contents of the index field is then updated after each successful search to indicate at which array element the next search should begin.

C		Form Type		Control Level (LD, L9, LR, SR, AN/OR)		Indicators		Factor 1		Operation		Factor 2		Result Field		Resulting Indicators		Comments	
Line						And	And							Name	Length	High	Low	Equal	
01	C							MFGPT		LOKUP	QTY					33			QTY LESS THAN 25
02	C																		

Figure 9-38. Array Search Which Locates Only One Element

The first search should begin at element 1. Thus, as Figure 9-39 shows, the index field IX is initially set up to contain the value 1. (The field is zeroed before adding 1, since you have no way of knowing the contents of IX at the beginning of the program run.) The TAG operation is not performed; therefore, the computer skips this specification and performs the LOKUP.

When the first QTY element less than 25 is found, the number of the element (04) is placed in the index field. Providing the LOKUP was successful (33 on), a 1 is added to the value in the index field, to indicate at which element the next search should begin. The value in the index field is then compared to 26 to see if the entire array (25 fields) has been searched. If there are still array elements to be checked (indicator 44 on), the program branches back (GOTO) to perform the LOKUP again. The search would then begin again, only at the element following the last element which satisfied the search. The calculation specifications would be repeated over and over until all items to be manufactured are located and until the end of the array is reached.

### Output During an Array Search

The specifications in Figure 9-40 search through the QTY array to locate more than one element. In this case, it does no good to search through an array unless you know what

data was found. For this reason, each quantity less than 25 and its related item code are printed. Following each successful search, the item code number (same as the number of the array element containing the quantity) is stored in the index field IX. Thus, the field IX can be printed. The actual quantity which satisfied the search can be printed by specifying the array name with the index field in the output specification.

Since the output specifications usually are not performed until all calculations are done, normal output would be invalid since there would be an attempt to reference array element 26.

In order to print each item code (field number) located in the array search (and its quantity), output must be done before the contents of the index field are changed.

You have learned that using the EXCPT operation on the Calculation sheet makes it possible to perform output specifications before calculations are finished and then to return to finish the calculation operations. As Figure 9-40 shows, following a successful LOKUP, the EXCPT operation then causes the data placed in the index field to be printed, followed by the contents of the array element which satisfied the search. After the exception output has been performed (output lines identified by an E in column 15), the program continues with the calculation specifications by executing the calculation which follows the EXCPT operation.

IBM		International Business Machine Corporation		RPG CALCULATION SPECIFICATIONS																																								Form GX21-9093 Printed in U.S.A.	
Program		Punching Instruction		Graphic		Card Electro Number		Page 1 2 of 75 76 77 78 79 80		Program Identification																																			
Programmer		Date		Punch																																									
Line	Form Type	Control Level (L, O, L, L, R, SR, AN, OR)	Indicators			Factor 1	Operation	Factor 2	Result Field		Resulting Indicators			Comments																															
			And	And	Not				Name	Length	Arithmetic	Plus	Minus		Zero																														
			Not	Not	Not						1 > 2	1 < 2	1 = 2																																
											Lookup(Factor 2)is																																		
											High	Low	Equal																																
0 1	C						Z-ADD 01	IX	20					START AT FLD #1																															
0 2	C					AGAIN	TAG																																						
0 3	C					MEGPT	LOKUP QTY, IX																																						
0 4	C		33			IX	ADD 01	IX					33	QTY LESS THAN 25																															
0 5	C		33			IX	COMP 26						44	END OF ARRAY?																															
0 6	C		44	33			GOTO AGAIN							NO-SEARCH NEXT																															
0 7	C																																												
0 8	C																																												
0 9	C																																												

Figure 9-39. Repeating a LOKUP to Locate All Array Elements Satisfying the Search Condition

## LOADING ARRAYS

In the beginning of this chapter (*Defining an Array*), you learned that arrays are divided into three types based on when the array data is stored into the array. The three different times are compilation time, pre-execution time, and execution time. Data can be stored in any of the following ways:

- **Compilation time:** keyed in on a console (keyboard) device; read from punched cards, tape, or disk source library
- **Pre-execution time:** keyed in on a console device; read from punched cards, tape, or disk
- **Execution time:** Extracted from an input file on a console device, punched cards, tape, or disk during execution of the program
- **Execution time:** Created by calculations performed during the program

## Compile Time Arrays

Arrays loaded at the same time as your RPG II source program are referred to as compile time arrays. The array is compiled along with the RPG II source program. The array data actually becomes part of the object program. One definite advantage in creating compile time arrays is that you need not load separate array files into the computer every time you wish to run that object program.

### RPG CALCULATION SPECIFICATIONS

Form GX21-9093 Printed in U.S.A.

Page 1 of 2      Program Identification 75 76 77 78 79 80

IBM International Business Machine Corporation

Program: \_\_\_\_\_      Punching Instruction: \_\_\_\_\_      Graphic: \_\_\_\_\_      Card Electro Number: \_\_\_\_\_

Programmer: \_\_\_\_\_      Date: \_\_\_\_\_      Punch: \_\_\_\_\_

Line	Form Type	Control Level (LD LG, LR, SR, AN/DR)	Indicators				Factor 1	Operation	Factor 2	Result Field		Resulting Indicators	Comments
			And	And	Not	Not				Name	Length		
01	C						Z-ADD 01		IX	20			START ELEMNT ONE
02	C						AGAIN TAG						
03	C						MFGPT LOKUPQTY,IX				33		QTY LESS THAN 25
04	C		33				EXCPT						PRINT #FLD, QTY
05	C		33				IX ADD 01		IX				ADD TO INDEX
06	C		33				IX COMP 26				44		END OF ARRAY?
07	C		44	33			GOTO AGAIN						NO-SEARCH NEXT

Arithmetic	Plus	Minus	Zero
1	2	3	4
Compare	> 2	1	< 2
1	2	3	4
Lookup Factor 2's	High	Low	Equal
53	54	55	56
57	58	59	60

### RPG OUTPUT SPECIFICATIONS

Form GX21-9090 U/M 0507 Printed in U.S.A.

Page 1 of 2      Program Identification 75 76 77 78 79 80

IBM International Business Machine Corporation

Program: \_\_\_\_\_      Punching Instruction: \_\_\_\_\_      Graphic: \_\_\_\_\_      Card Electro Number: \_\_\_\_\_

Programmer: \_\_\_\_\_      Date: \_\_\_\_\_      Punch: \_\_\_\_\_

Line	Form Type	Filename	Output Indicators				Field Name	End Position in Output Record	Constant or Edit Word
			And	And	Not	Not			
01	O	PRINT					LP	45	'ITEM CODE QTY'
02	O								
03	O								
04	O						IX	29	
05	O						QTY,IX	45	

Figure 9-40. Output of Array Element as it is Located in the Search



### Changing Compile Time Arrays

Temporary changes to data in a compile time array exist only for a particular run and are made as easily as for any array. Calculation specifications which have been previously coded in the program can modify any of the array elements.

Making permanent changes to a compile time array requires recompiling the entire RPG II source program along with the new or changed array input records. The object program produced then contains the current array data.

### Loading Compile Time Arrays

An array to be compiled with your program should follow the RPG II source program (Figure 9-41). There should be a record immediately before the array containing \*\* in positions 1-2. Position 3 must be blank but remaining positions may be used for comments (such as the array name). If more than one array is to be compiled, a \*\* record should be placed before each array. Furthermore, the compile time arrays must be loaded in the same order as they are described on the Extension sheet. The end of file record (/\*) which usually comes at the end of the source program is then placed after the last compile time array.

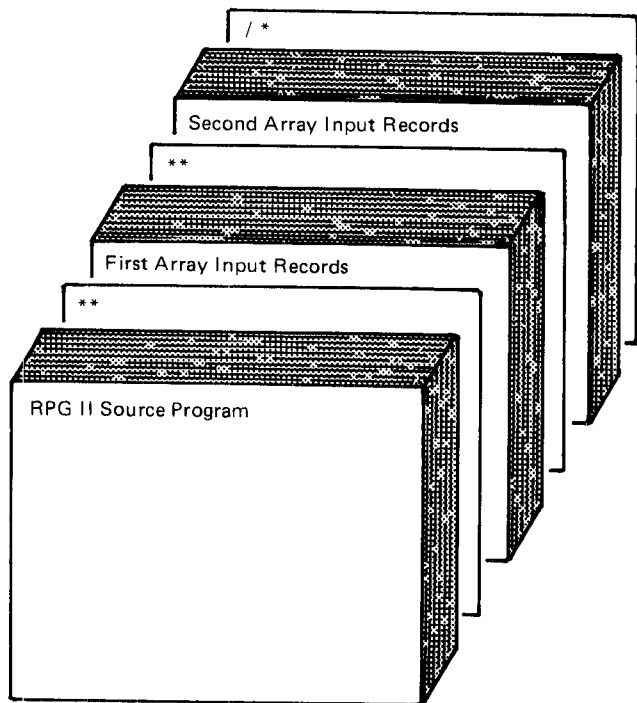

*Model 10 Card System Users:* The source program and array input records as shown here are placed in the secondary MFCU hopper. The RPG II Compiler program is placed in the primary hopper.

Figure 9-41. Arrangement of Input for Compile Time Arrays

Model 10 Disk System, Model 15, and Model 6 users may place compile time arrays in the source library following the source program. The same record sequence as shown in Figure 9-41 is used. See the applicable reference manuals for your system for specific procedures.

### Pre-execution Time Arrays

In general, if an array is to be permanently modified often, a pre-execution time array is easier to use than a compile time array. A pre-execution time array is not compiled with your RPG II source program. Instead, once the object program has been loaded into the computer to be executed, the array is loaded separately like an input data file. The array is then used by the object program, rather than being a part of the program.

### Changing a Pre-execution Time Array

Modifying a pre-execution time array is easier than changing a compile time array. Modifying the contents of the array permanently (whether a short array or a full array) can be done by inserting and deleting change records. In any event, only the array file is changed; there is no need to make changes in the RPG II object program.

### Loading Pre-execution Time Arrays

Pre-execution time arrays are similar to any other input data files in that the RPG II object program uses the files when the program is executed. Unlike other data files, however, pre-execution time arrays are read completely before execution of the program continues.

The array files should be in the same order as for compile time arrays. All array files are to be loaded in the same order as they are described on the Extension sheet. Furthermore, if both pre-execution time array files and other input data files are to be used by a program, all arrays must be loaded before the data files. An end of file card (/\*) must follow every pre-execution time array file, regardless of whether the array is short or full (Figure 9-42).

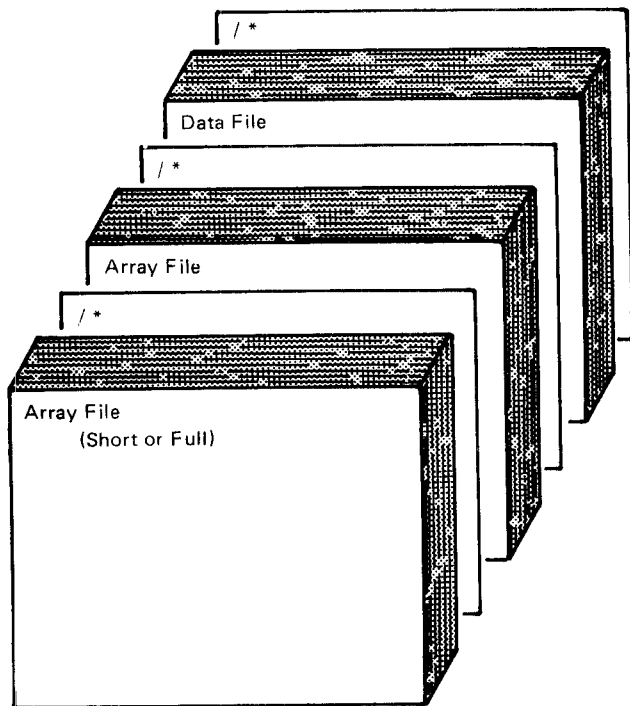

*Specifications for Pre-execution Time Arrays*

Since a pre-execution time array is a separate file to be used by the program, the entire file of array input records must be defined on the File Description sheet, just as any other file must be. Figure 9-43 shows the file description specifications required to define a pre-execution time array input file. A filename, different from the array name, should be assigned to the entire array file (columns 7-14). A unique filename should be assigned because the single file may actually contain data for two arrays, if alternating format records are used. Figure 9-43 shows a file called ARFILE, containing data for both ARRAYA and ARRAYB. An I in column 15 says that ARFILE is an input file. Notice also, that the File Designation entry (column 16) must be a T, to indicate that this is an array file, as well (T stands for either a table file or an array file). The Device entry (columns 40-46) indicates the device from which the array file is read (for the Model 10 Card System, the entry must be MFCU2).

**Model 10 Card System Users:** The array files are loaded from the secondary MFCU hopper. The RPG II object program is loaded from the primary hopper.

**Other Systems:** Array files loaded at pre-execution time may be loaded from console, cards, disk or tape.

**Figure 9-42. Arrangement of Input for Pre-execution Time Arrays**

**File Description Specification**

Line	Form Type	Filename	File Type		Mode of Processing		Device	Symbolic Device	Name of Label Exit	Extent Exit for DAM	File Addition/Unordered	
			File Designation	End of File	Length of Key Field or of Record Address Field	Record Address Type					Number of Tracks for Cylinder Overflow	Number of Extents
02	F	ARFILE	I	T	F	90	90	EDISK				
03	F	Filename differs from array names										
04	F											

**RPG EXTENSION AND LINE COUNTER SPECIFICATIONS**

IBM International Business Machine Corporation

Program: \_\_\_\_\_ Date: \_\_\_\_\_ Punching Instruction: \_\_\_\_\_ Graphic: \_\_\_\_\_ Card Electro Number: \_\_\_\_\_

Page 1 of 2 Program Identification 75 76 77 78 79 80

**Extension Specifications**

Line	Form Type	Record Sequence of the Chaining File		To Filename	Table or Array Name	Number of Entries Per Record	Number of Entries Per Table or Array	Length of Entry	Table or Array Name (Alternating Format)	Length of Entry	Comments
		Number of the Chaining Field	From Filename								
01	E			ARFILE	ARRAYA	5	100	3	ARRAYB	15	ALTERNATING ARRAY
02	E										
03	E										

Information which relates this specification to a particular File Description specification

**Figure 9-43. Defining a Pre-execution Time Array File**

Ordinarily, if an input file is to be in a particular sequence, an entry (A or D) is made in column 18 of the File Description sheet. When specifying a sequence for array files, however, the sequence columns (45 and 57) on the Extension sheet must be used, rather than the sequence column on the File Description sheet. An E has been entered in column 39 of the File Description sheet to indicate that the records in this array file are further described on the Extension sheet.

Looking at Figure 9-43, you can see that the filename assigned on the File Description sheet is also entered under From Filename (columns 11-18) of the Extension sheet. This common entry tells the computer that the extension specifications describing ARRAYA and ARRAYB arrays are associated with the ARFILE file defined on the File Description sheet. For compile time arrays, previously described, no entry is made in columns 11-18, since no filename is assigned to compile time array records.

### Storing Input Data into Execution Time Arrays

When an execution time array is defined in an extension specification, an array is set up in the computer, ready to receive array data. You have learned that the array data can either be generated by calculations in your program or be taken from an input file that your program reads. There is an important difference between the input file used to build an execution time array and the input file used to build a pre-execution time array (see *Loading Arrays, Pre-execution Time Arrays*). That is, the input file from which an execution time array is built is not a special array file designated by a T in column 16 of the File Description sheet. Therefore, the array data is not automatically loaded into the array at the beginning of execution time. Instead, you must describe the input data to be loaded into the array on input specifications and ensure that the necessary data is in the array before doing operations that use the array data.

Fields of array data to be read from input records must be described on the Input sheet. The input specifications indicate where the data is located on the record. How the array information is described and stored depends on three factors:

1. How the array data is organized on a record.
2. Whether the data for an array is contained in one or more records.
3. Which System/3 model you are using.

An input record containing array data can contain only data for that array or can contain both array data and other data fields to be used in the program. In either case, the array data is organized in one of two ways:

1. All array elements may occupy consecutive positions on the record; that is, each element immediately following another with no blanks or other data between the elements.
2. The array elements may be scattered on the record, in any order, with blanks or normal input fields placed between the array elements.

The way in which the data is organized and the size of the array generally determines the number of input records required to contain the array data.

#### *Array Data in Consecutive Positions on One Record*

if array elements are in order in consecutive positions on a record, describing and storing the data is very easy. All of the array data on the one record may be described on the Input sheet as if it were a single field. Thus, only one input specification is necessary to indicate a name for the field and the columns on the record where the array data begins and ends (Figure 9-44). By specifying the name of the array as the field name, the data is automatically stored in the appropriate elements of the array as the input record is read.

When you describe an input record of array data, you specify no entry in column 52 (Decimal Positions) of the Input sheet. Since the array name and characteristics have been previously defined on the Extension sheet, the entry in column 44 of the Extension sheet indicates the number of decimal positions in each array element.

#### *Array Data Scattered on One Record*

When array elements are scattered on an input record, each field must be described separately on the Input sheet to indicate where each item of array data begins and ends. Two methods are available to load the data into the array:

1. Assign a unique field name to each field of array data on the input record, then code calculations to move each data field individually into the appropriate array element.
2. Assign the array name with the proper index to each field of array data *in the input record* and the array will be loaded automatically as the data is read. (This method of loading array data is not available for the System/3 Model 10 Card System.)

## RPG EXTENSION AND LINE COUNTER SPECIFICATIONS

Form X21.9091  
Printed in U.S.A.

**IBM** International Business Machine Corporation

Program	Punching Instruction	Graphic	Card Electro Number
Programmer	Date	Punch	

Page 1 of 2      Program Identification 75 76 77 78 79 80

### Extension Specifications

Line	Form Type	Record Sequence of the Chaining File		To Filename	Table or Array Name	Number of Entries Per Record	Number of Entries Per Table or Array	Length of Entry	P/B/L/R	Decimal Positions Sequence (A/D)	Table or Array Name (Alternating Format)	Length of Entry	P/B/L/R	Decimal Positions Sequence (A/D)	Comments	
		From Filename	Number of the Chaining Field													
0 1	E				PAY			6				5			2	
0 2	E															

### RPG INPUT SPECIFICATIONS

GX21.9094 U/M 050\*  
Printed in U.S.A.

**IBM** International Business Machine Corporation

Program	Punching Instruction	Graphic	Card Electro Number
Programmer	Date	Punch	

Page 1 of 2      Program Identification 75 76 77 78 79 80

Line	Form Type	Filename	Sequence Number (LIN) A/N/D	Record Identification Codes									Field Location			Field Indicators						
				1			2			3			From	To	Field Name	Control Level (1-14)	Matching Fields or Chaining Fields	Field Record Relation	Plus	Minus	Zero or Blank	
Position	Not (N) C/Z/D	Character	Position	Not (N) C/Z/D	Character	Position	Not (N) C/Z/D	Character	Stacking Select	P/B/L/R	From	To	Field Name	Control Level (1-14)	Matching Fields or Chaining Fields	Field Record Relation	Plus	Minus	Zero or Blank			
0 1	I	INPUT		01		I	CS															
0 2	I										3	32	PAY									

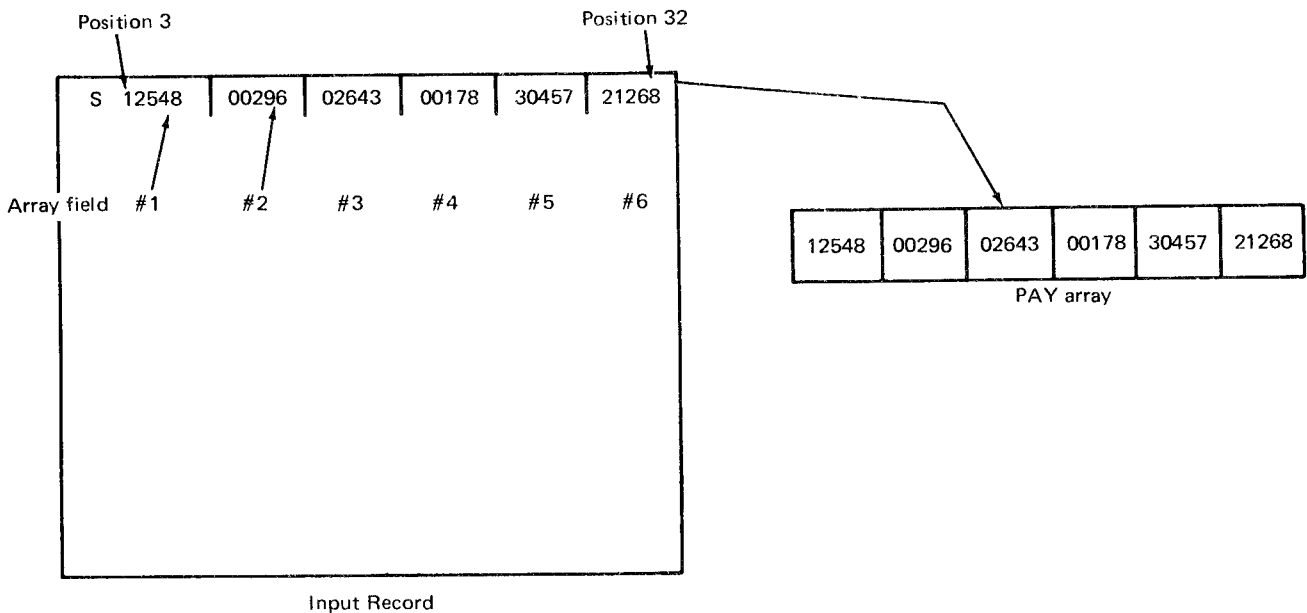

**Figure 9-44. Storing Data in an Array**

Assume that a 6-field array named EMP is set up by coding extension specifications. The six fields of data for the array are scattered on a record, as shown in Figure 9-45. Additional input information (blanks and other input fields) is recorded between the array fields. Furthermore, the array fields are not in the order in which they are to be stored.

When you describe the array data, you must identify each field by a separate line of input specifications, because the array data is not continuous. Normal input fields can be described along with the array fields. Separate fields can be identified and stored as follows:

*All System/3 Models:* One way to identify and store array data is shown in Figure 9-46. Unique field names are assigned to individual fields of array data on the Input sheet. Once the scattered fields have been described on the Input sheet, each field of array data is stored in the array using a MOVE calculation. Since each field has a unique field name and must be stored in a specific array element, a separate move specification must be coded for each field to be stored.

The specifications which move the array data into the array elements should generally be specified first on the Calculation sheet. This ensures that the data will be in the array when any calculations on the array (specified later on the Calculation sheet) are performed.

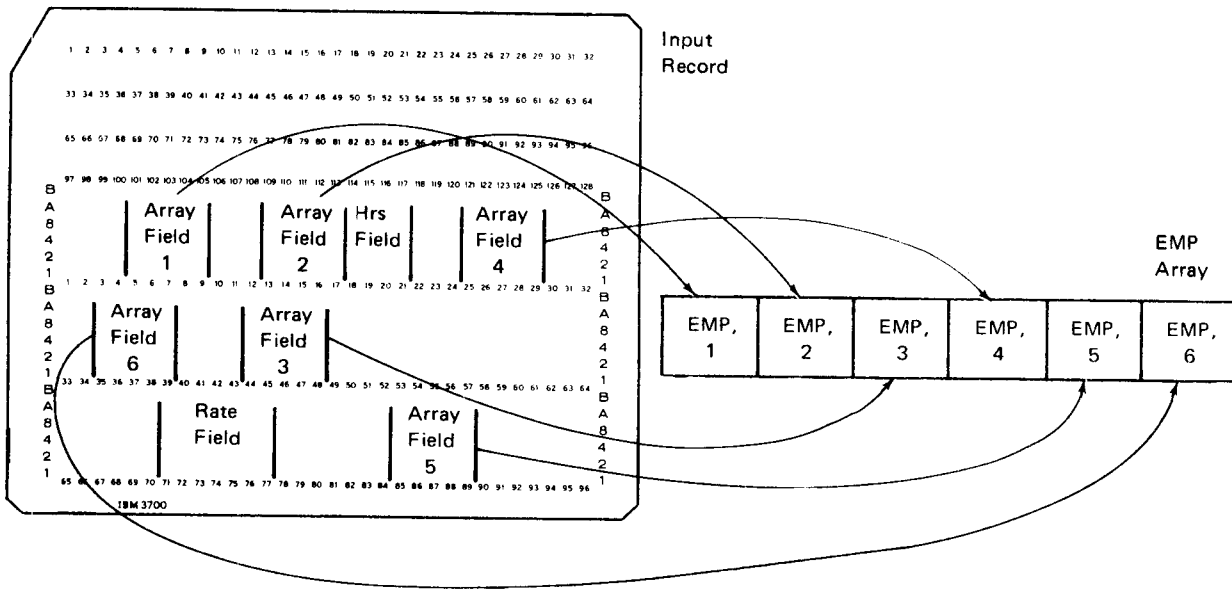

Figure 9-45. Scattered Fields of Array Data in One Input Record



All System/3 Models (Except Model 10 Card System and Model 15C): Figure 9-47 shows a second way to load an array from scattered fields. The array name with an index is assigned to each field of data in the input record. In this way, the data is loaded directly into the array as the fields are read. No move calculations are necessary.

Array Data Consecutive on More Than One Record (Model 10 Card System)

Consider a case where the array data on all input records is organized consecutively. Data for a 25-element array named TAX is contained on two input records (Figure 9-48). The first record contains 19 fields, the second record, six. Each numeric field is five characters long. The data is organized on the records in the order it is to be stored in the array.

IBM		RPG EXTENSION AND LINE COUNTER SPECIFICATIONS																					Form X21-9091 Perforated U.S.A.	
Program				Punching Instruction				Graphic				Card Electro Number				Page 1 2 of 75 76 77 78 79 80		Program Identification						
Programmer				Date				Punch																
Extension Specifications																								
Line	Form Type	Record Sequence of the Chaining File		To Filename	Table or Array Name	Number of Entries Per Record	Number of Entries Per Table or Array	Length of Entry	Table or Array Name (Abbreviated)	Method of Entry	Subsequent P/B's	Subsequent V/D's	Comments											
		From Filename	Number of the Chaining Field																					
01	E				EMP			6	5	0														
02	E																							
03	E																							

IBM		RPG INPUT SPECIFICATIONS																					Form X21-9094 Perforated U.S.A.			
Program				Punching Instruction				Graphic				Card Electro Number				Page 1 2 of 75 76 77 78 79 80		Program Identification								
Programmer				Date				Punch																		
Line	Form Type	Filename	Sequence Number (HN)	Chain (ID)	Record Identifying Indicator or	Record Identification Codes									Field Location		Field Name	Control Level (L/E)	Maximum Fields Chaining Keys	Field Record Designation	Field Indicators					
						Position	Not (N)	C/Z/D	Character	Position	Not (N)	C/Z/D	Character	Position	Not (N)	C/Z/D					Character	From	To	Plus	Minus	Zero or Blank
01	I	INPUT	AA	01		1																				
02	I														5	9	EMP, 1									
03	I														13	17	EMP, 2									
04	I														18		211HRS									
05	I														25	29	EMP, 4									
06	I														35	39	EMP, 6									
07	I														44	48	EMP, 3									
08	I														71	77	RATE									
09	I														85	89	EMP, 5									
10	I																									

Figure 9-47. Loading Array Data From Scattered Fields by Means of Input Specifications

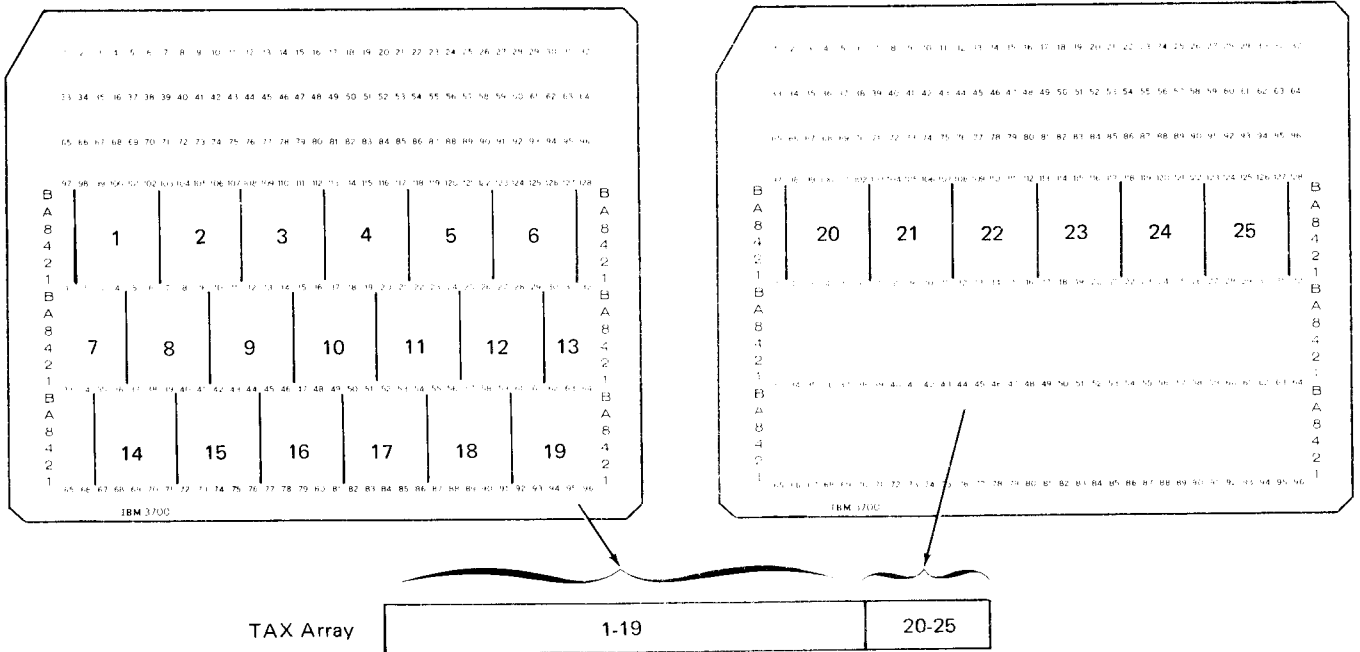

**RPG EXTENSION AND LINE COUNTER SPECIFICATIONS**

Form X21 9891  
Revised 10-5-64

Program: \_\_\_\_\_ Punched: \_\_\_\_\_ Graphics: \_\_\_\_\_ Card Electro Number: \_\_\_\_\_  
 Programmer: \_\_\_\_\_ Date: \_\_\_\_\_ Instruction: \_\_\_\_\_ Pages: \_\_\_\_\_ of \_\_\_\_\_ Program Identification: \_\_\_\_\_

**Extension Specifications**

Line	Form	Record Sequence of the Following File	To Filename	Table or Array Name	Number of Entries or Records	Name of Table or Array	Length of Entry	Table or Array Name (Observation)	Length of Entry	Comments
01	E			TAX	25	5				

**RPG INPUT SPECIFICATIONS**

Form X21 9894  
Revised 10-5-64

Program: \_\_\_\_\_ Punched: \_\_\_\_\_ Graphics: \_\_\_\_\_ Card Electro Number: \_\_\_\_\_  
 Programmer: \_\_\_\_\_ Date: \_\_\_\_\_ Instruction: \_\_\_\_\_ Pages: \_\_\_\_\_ of \_\_\_\_\_ Program Identification: \_\_\_\_\_

Line	Form	Filename	Sequence Number (OR)	Record Identification Code	Record Identification Codes			Field Location		Comments
					Position	Start (S)	End (E)	From	To	
01	I	INPUT	AA	Ø1	1	D1				
02	I						2	96	TAX	
03	I		AA	Ø2	1	D2				
04	I						2	6	TAX, 20	
05	I						7	11	TAX, 21	
06	I						12	16	TAX, 22	
07	I						17	21	TAX, 23	
08	I						22	26	TAX, 24	
09	I						27	31	TAX, 25	

The array elements on the second record need not be loaded separately on the Model 10 Disk System, Model 6, or Model 15, since the MOVEA operation code is available on these systems.

Figure 9-48. Loading Array Data Consecutive on More than One Record (Model 10 Card System)



It is important to note that when data is stored in an array by specifying the array name as the field name, the information is placed at the beginning of the array. Thus, the 95 columns of data from this first input record are stored in elements 1-19 of the array (Figure 9-48).

Although the data on the second record is also arranged consecutively, each element is loaded separately. The second record cannot be defined as a single array field and stored automatically in the array because the data would be stored at the beginning of the array, destroying the data previously stored at the beginning of the array. Instead, the data from the second record is loaded by defining the individual fields as array elements on the Input sheet (Figure 9-48). The data could also be loaded by assigning a unique fieldname to each field of array data on the second record and using MOVE operations to move each field to its proper array element. In this case, specifications would be similar to those for the EMP array in Figure 9-46.

In this example, the method of defining and storing data in the TAX array is relatively simple. However, if there are a large number of data fields contained on records other than the first, storing the data can require a great number of coding lines. Suppose, for example, the TAX array consists of 50 fields. Three records are required to contain the data. The first two records contain 19 fields each; the third contains 12 fields. Storing the data using the method shown in Figure 9-48 requires 31 separate lines of coding to load the data on records two and three. Because of this, you might want to consider loading the array as a compile time or pre-execution time array, instead.

#### **Array Data Consecutive on More Than One Record (Model 6, Model 10, Model 12 and Model 15)**

On the Model 6, Model 10, Model 12 and Model 15, it is much easier to load array data that is consecutive on more than one input record. Consider the previous example (Figure 9-48). The array data on the second record can be described as a single field on these systems, because the MOVEA operation code is available on these systems to move data from a field to an array. Figure 9-49 shows the coding necessary to load the TAX array when the MOVEA operation is used in calculations.

Using the MOVEA operation, data that is consecutive on many input records can conveniently be loaded during program execution. See your RPG II Reference Manual for a complete description of the use of MOVEA.

### RPG EXTENSION AND LINE COUNTER SPECIFICATIONS

Form X21-9091  
Printed in U.S.A.

**IBM** International Business Machine Corporation

Program	Punching Instruction	Graphic	Card Electro Number
Programmer	Date	Punch	

Page 1 of 2 Program Identification 75 76 77 78 79 80

#### Extension Specifications

Line	Form Type	Record Sequence of the Chaining File																To Filename	Table or Array Name	Number of Entries Per Record	Number of Entries Per Table or Array	Length of Entry	P/B L/R	Decimal Positions	Sequencer (A/D)	Table or Array Name (Alternating Format)	Length of Entry	P/B L/R	Decimal Positions	Sequencer (A/D)	Comments					
		Number of the Chaining Field								From Filename																										
01	E																	TAX		25	5															
02	E																																			

### RPG INPUT SPECIFICATIONS

GX21-9094 U/M 0501  
Printed in U.S.A.

**IBM** International Business Machine Corporation

Program	Punching Instruction	Graphic	Card Electro Number
Programmer	Date	Punch	

Page 1 of 2 Program Identification 75 76 77 78 79 80

Line	Form Type	Filename	Sequence Number (1-N)	Option (O)	Record Identification Codes									Field Location		Field Name	Control Level (1-1-B)	Matching Fields or Chaining Fields	Field Record Relation	Field Indicators			
					1	2	3	4	5	6	7	8	9	10	From					To	Plus	Minus	Zero or Blank
01	I	INPUT	AA	01	L	D									2	96	TAX						
03	I		AA	02	L	D									2	31	TAXEND						

### RPG CALCULATION SPECIFICATIONS

Form GX21-9093  
Printed in U.S.A.

**IBM** International Business Machine Corporation

Program	Punching Instruction	Graphic	Card Electro Number
Programmer	Date	Punch	

Page 1 of 2 Program Identification 75 76 77 78 79 80

Line	Form Type	Control Level (LD-L9, LR, SR, AN/OR)	Indicators					Factor 1	Operation	Factor 2	Result Field		Resulting Indicators	Comments	
			And	And	Not	Not	Not				Name	Length			Plus
01	C	02						MOVE	TAX	20					TAX, 20

● Figure 9-49. Loading Array Data Consecutive on More Than One Record (Model 6, Model 10 Disk System, and Model 15)

### *Array Data Scattered on More Than One Record*

Regardless of how many records are used to contain array data, if the fields are scattered on the records, each field must be individually loaded into its appropriate position in the array. However, a separate specification is not always necessary for each field of data to be loaded. In some cases, the same specification can be used for all the records. This depends on whether all the input records for a single array are organized in the same format and whether the fields from different records can be assigned the same name.

Assume that a 22-element array, named ARA, is defined. The data for the array is scattered on six input records, as shown in Figure 9-50. Although the array data is not consecutive, the four fields on each of the first five records are in the same format on each record. The remaining two fields on the sixth record are in the same format as the first two fields on all other records.

Since the array data follows the same organization on all records, describing one set of fields (Figure 9-51) actually describes the fields on all records, except the last. A separate input specification should be coded to indicate that record 6 only contains two of the fields. (Note on the Input sheet that records 1-5 are described in an OR relationship. Therefore, a specific card sequence cannot be specified in columns 15 and 16. You can assume that the array input records are in sequence. Record type 1 is the first record read and record type 6 is the last.)

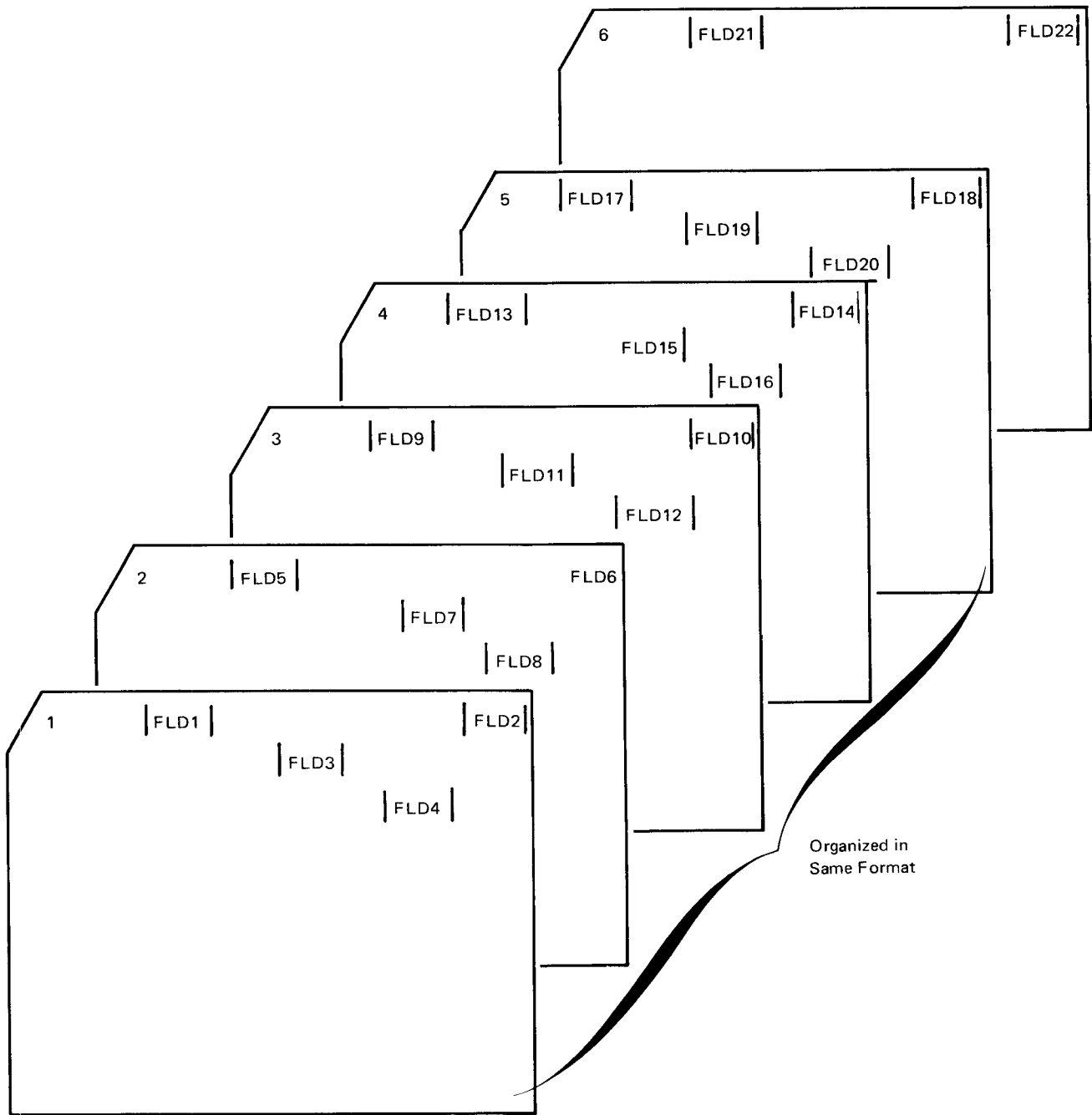

Figure 9-50. Array Data Scattered on More than One Record



Because the fields on the different records have the same field names, only one MOVE specification is necessary for each unique field name. The specification on line 07 of Figure 9-52, when repeated for each record, moves FLDA of that record to the appropriate element of the ARA array. Lines 09 and 10 are performed for every record except the last, which does not have fields FLDC and FLDD.

way, the values in the index fields only have to be changed every time another array input record is processed. When the first record is read, the index fields A, B, C, and D are initialized to 1, 2, 3, and 4, respectively, to prepare for moving the fields from record type 1 (Figure 9-52, lines 01-04). After the four fields are moved, the value 4 is added to each of the index fields so they point to where the four fields on the next record should be stored (Figure 9-52, lines 12-15). The same calculation specifications are repeated until fields FLDA and FLDB from the sixth record have been moved to the last two array elements.

Since the fields on the input records are in the same order as they are to be stored in ARA, a definite pattern is established as to where the data is to be moved. Fields from record 1 are stored in array elements one through four, fields from record 2 in array elements 5 through 8, fields from record 3 in array elements 9 through 12, and so on.

*Conditioning Operations Until All Array Data is Stored*

Array index fields can be used to indicate to which array elements that data is to be moved. For each unique field name, an individual index field should be set up. In this

All information must be stored in an array before you can reference the data by specifying the array name or array name with an index. Thus, any specifications to load the data into the array must be specified before any calculations which use the array information.

RPG CALCULATION SPECIFICATIONS																																																																					
IBM International Business Machine Corporation						Form GX21 5093 2 Printed in U.S.A.																																																															
Program _____							Punching Instruction _____							Graphic Punch _____							Card Electre Number _____							Page 1 of 2							Program Identification 75 76 77 78 79 80																																		
C	Line	Form Type	Control Level (LO, L1, L2, L3, L4, L5, L6, L7, L8, L9, L0, SR, AN, OR)	Indicators		Factor 1	Operation	Factor 2	Result Field		Resulting Indicators			Comments																																																							
				And	And				Name	Length	Decimal Positions	Plu	Mnus		Zero																																																						
				9 Not	10 Not					0	1	2																																																									
	01	C		Ø1			Z-ADD1		A	2	Ø			SET UP INDEX																																																							
	02	C		Ø1			Z-ADD2		B	2	Ø			FIELDS FOR																																																							
	03	C		Ø1			Z-ADD3		C	2	Ø			MOVING DATA																																																							
	04	C		Ø1			Z-ADD4		D	2	Ø																																																										
	05	C	*																																																																		
	06	C	*																																																																		
	07	C					MOVE FLDA		ARA, A					MOVE DATA TO																																																							
	08	C					MOVE FLDB		ARA, B					PROPER ARRAY																																																							
	09	C		NØ6			MOVE FLDC		ARA, C					FIELDS																																																							
	10	C		NØ6			MOVE FLDD		ARA, D																																																												
	11	C	*																																																																		
	12	C		NØ6		A	ADD X4		A					INCREASE INDEX																																																							
	13	C		NØ6		B	ADD X4		B					VALUES TO MOVE																																																							
	14	C		NØ6		C	ADD X4		C					DATA FROM NEXT																																																							
	15	C		NØ6		D	ADD X4		D					RECORD																																																							
	16	C																																																																			

Figure 9-52. Using the Same MOVE for Fields from Several Records



Figure 9-54 shows how the array operations must be conditioned for another situation. In this case, record identifying indicator 06 does not set on indicator 33 because information (DSCNT) from data records following the array records must be available before the array operations can be performed (line 16). If indicator 06 caused indicator 33 to be set on, the array operations would be performed during the program cycle in which the sixth array record is stored. At that point, the DSCNT data is not available. Therefore, record identifying indicator 09 (the first type of data card following the array records) sets on the conditioning indicator 33 instead.

At this point, we must mention a problem which can come up if array elements are contained on more than one record (or the same record type), and the records contain normal input data as well as array data. Assume three cards contain the array data and all the data must be stored in the array prior to performing any calculation or output operations. This means the three records must be read before processing. As each new record (of the same record type) is read, the data from the previous record is destroyed, unless it has been moved or stored in a special place, such as an array. Since normal input data (nonarray fields) from the first two records is no longer available once the third record has been read, any calculation or output specifications which reference this input data might give incorrect results.

Form GX21-9033  
Printed in U.S.A.

IBM International Business Machine Corporation						<b>RPG CALCULATION SPECIFICATIONS</b>																			
Program		Punching Instruction		Graphic		Card Electro Number				Page 1 2 of _____		Program Identification 75 76 77 78 79 80													
Programmer		Date		Punch																					

C	Line	Form Type Control Level (L, O, L, S, E, A, SR, AN, OR)	Indicators					Factor 1	Operation	Result Field		Decimal Positions: Half Adjust (H)	Resulting Indicators		Comments		
			01	02	03	04	05			Name	Length		Arithmetic				
													Plus	Minus		Zero	
	01	C	01					SETOF									
	02	C	01					Z-ADD1	A	20							
	03	C	01					Z-ADD2	B	20							
	04	C	01					Z-ADD3	C	20							
	05	C	01					Z-ADD4	D	20							
	06	C						MOVE FLDA	ARA,A					} Move data from input record into array			
	07	C						MOVE FLDB	ARA,B								
	08	C	06					MOVE FLDC	ARA,C								
	09	C	06					MOVE FLDD	ARA,D								
	10	C	06			A		ADD H	A								
	11	C	06			B		ADD H	B								
	12	C	06			C		ADD H	C								
	13	C	06			D		ADD H	D								
	14	C	09					SETON									
	15	C															
	16	C	33				ARA, 22	SUB DSCNT	ARA, 22								
	17	C	33					XFCOTARA	SUMALL								

\* 09 set on by reading first data record following array input records.

Field of data on the data records which follow the array input records.

Figure 9-54. Conditioning Operations Until All Array Data is Stored and Input Data is Available





1. In which of the following ways is an array like a table (state true or false and the reasons for your answer)?
  - a. Each can be referenced as one group of information.
  - b. Each is a continuous series of data fields (elements) stored side by side.
  - c. A particular item of data can be individually referenced in either a table or an array.
  - d. Each is defined by coding extension specifications.
2. Can one array be compared to another array to determine which is greater or less? State the reason for your answer.
3. Explain what happens if an array (*a*) of 18 elements is added to an array (*b*) of three elements, with the result placed in an array (*c*) of 18 elements.
4. The following array (ARASIX) is to be set up during a program run:

1	2	72	5	20	15
---	---	----	---	----	----

- a. Define the array on an Extension sheet.
  - b. If ARASIX is multiplied by 3, what data will be placed in the result array RESARA?
  - c. Should the result array RESARA be defined on the Extension sheet also?
  - d. If so, code the necessary extension specifications to define RESARA.
  - e. What is accomplished by defining an array on the Extension sheet?
5.
  - a. Explain what happens when an XFOOT operation is performed.
  - b. If ARASIX (refer to question 3) is specified on the Calculation sheet as Factor 2 of an XFOOT operation, what data would be placed in the result field?
6. How does a programmer specify that an entire array is to be printed or punched (a) during output time in the object program cycle; (b) at end of job?
7. How does a programmer specify whether an entire array or only a particular array element is to be operated upon or used for output?

8. Data for a SALES array is recorded on a one-record input file called INFILE in the following format:

<i>Field</i>	<i>Columns</i>	<i>Field</i>	<i>Columns</i>
Clerk1	1-10	Clerk6	51-60
Clerk2	11-20	Clerk7	61-70
Clerk3	21-30	Clerk8	71-80
Clerk4	31-40	Clerk9	81-90
Clerk5	41-50	record code	91 (not array data)

Each of the clerk fields contains data with two decimal positions. Code the specifications necessary to:

- Define the array as a pre-execution time array.
  - If necessary, describe the input record and store the data in the SALES array.
9. Show two ways that data from the first five fields of the following record could be stored in an execution time array named SET (15 elements, three numeric characters each, no decimal positions). Column 1 of the record contains a P as the record identifying code.

Field	Columns	Field	Columns	Field	Columns
Fld1	2-4	Fld6	22-24	Fld11	42-44
Fld2	6-8	Fld7	26-28	Fld12	46-48
Fld3	10-12	Fld8	30-32	Fld13	50-52
Fld4	14-16	Fld9	34-36	Fld14	54-56
Fld5	18-20	Fld10	38-40	Fld15	58-60

- Code the output specifications to print the 13th element of the array SET (output filename PRINT).
  - Code the specifications to print the entire array SET at end of job (output filename PRINT).
11. SEARCH is the name of a field containing data you wish to locate in the 6-element PAY array. Code the specifications to search the array to determine if the data is present. If present, print the number and contents of the array element. If more than one array element satisfies the search, each is to be printed.
12. Code specifications to:
- Add ARA1 to ARA2 and place the result in ARA2.
  - Sum all elements of ARA2 and place the result in TOTAL.
  - Print both results.

1.
  - a. False. Only one table element can be referenced at one time.
  - b. True.
  - c. True.
  - d. True.
2. No. An operation to be performed on an array is repeated for each element in the array. Therefore, a compare (COMP) operation cannot give a meaningful result for the entire array. The two arrays, however, could be totaled using the XFOOT operation and the resulting totals could be compared.
3. The first three elements of array *a* would be added to the three elements of array *b*, with the three results placed in the first three elements of array *c*. The remaining 15 elements of array *c* (result array) remain unchanged.
4.
  - a. Entries shown are required; no other entries should be made. The entry in column 44 is necessary to indicate the elements are numeric for arithmetic operations.

**Extension Specifications**

Line	Form Type	Record Sequence of the Chaining File		To Filename	Table or Array Name	Number of Entries Per Record	Number of Entries Per Table or Array	Length of Entry	P/B/L/R	Decimal Positions Sequence (A/D)	Table or Array Name (Alternating Format)	Length of Entry	P/B/L/R	Decimal Positions Sequence (A/D)	Comments	
		Record Sequence of the Chaining File	Number of the Chaining Field													
01	E				ARASTX		6	2	0							
02	E															

b.

3	6	216	15	60	45
---	---	-----	----	----	----

- c. Yes, all arrays to be used in a program must be defined on the Extension sheet.
- d. Entries shown are required; no other entries should be made. Length of array element (columns 40-42) must be 3 to contain the largest addition result.

**Extension Specifications**

Line	Form Type	Record Sequence of the Chaining File		To Filename	Table or Array Name	Number of Entries Per Record	Number of Entries Per Table or Array	Length of Entry	P/B/L/R	Decimal Positions Sequence (A/D)	Table or Array Name (Alternating Format)	Length of Entry	P/B/L/R	Decimal Positions Sequence (A/D)	Comments	
		Record Sequence of the Chaining File	Number of the Chaining Field													
01	E				RESARA		6	3	0							

- e. An area in storage sufficient to contain the array data is reserved. The actual array data may be stored in the array later, when input records are read or during calculations.

5. a. The XFOOT operation causes all elements in the array specified as Factor 2 to be added together. The single result of the additions is placed in the result field specified with the XFOOT operation.
- b. The total of all elements in the ARASIX array (115) would be placed in the result field.
  
6. a. The name of the array is specified under Field Name (columns 32 through 37) on the Output sheet. The filename (columns 7 through 14) must also be specified, as for output of any field.
- b. The name of the output file is specified under To Filename (columns 19-26) on the Extension sheet. No entry is necessary on the Output sheet. (This method of array output cannot be used for execution time arrays.)
  
7. The array name is specified alone (on the Calculation or Output sheet) to reference the entire array. The array name must be followed by a comma and an index number or index field to reference only a particular array element.
  
8. a. Extension specifications to define the array:

Extension Specifications																												
E	Line	From File	Record Sequence of the Chaining File						To Filename	Table or Array Name	Number of Entries Per Record	Number of Entries Per Table or Array	Length of Entry	P.B.L.R.	Decimal Positions Sequence (A-D)	Table or Array Name (Alternating Format)	Length of Entry	P.B.L.R.	Decimal Positions Sequence (A-D)	Comments								
			From Filename																									
	1	E																										
	1	E						INFIL	SALES	9	9	10	2															

- b. Input specifications to describe the input record and store the data in the SALES array are not necessary, since the array is automatically loaded before execution of the program.

9. First method:

**IBM** International Business Machines Corporation CX21 9094 Q-M 1007  
© Copyright 1954

**RPG INPUT SPECIFICATIONS**

---

Program: \_\_\_\_\_ Date: \_\_\_\_\_ Punching Instruction: \_\_\_\_\_ Graphic Punch: \_\_\_\_\_ Card Electro Number: \_\_\_\_\_

Page  of  Program Identification: \_\_\_\_\_

---

I	Line	From File	Filename	Sequence Number (N)	Option (O)	Record Identifying Indicator	Record Identification Codes									Field Location				Field Indicators															
							1			2			3			From	To	Decimal Positions	Field Name	Control Level (L-U)	Matching Fields or Chaining Fields	Field Record Relation	Plus	Minus	Zero or Blank										
							Position	Start Character	End Character	Position	Start Character	End Character	Position	Start Character	End Character											Character	Stacked Select	P.B.L.R.							
	1	I	INPUT	AA	Ø	L																													
	2	I													2	4		SET, 1																	
	3	I													6	8		SET, 2																	
	4	I													10	12		SET, 3																	
	5	I													14	16		SET, 4																	
	6	I													18	20		SET, 5																	

Second method:

### RPG INPUT SPECIFICATIONS

GX21-9094 U/M 050  
Printed in U.S.A.

Program _____ Programmer _____			Punching Instruction _____ Date _____			Graphic _____ Punch _____				Card Electro Number _____				Page 1 of 2	Program Identification 75 76 77 78 79 80				
-----------------------------------	--	--	--	--	--	------------------------------	--	--	--	---------------------------	--	--	--	-------------	--	--	--	--	--

Line	Form Type	Filename	Sequence		Record Identification Codes			Field Location		Field Name	Field Indicators								
			C A N D	R	Position	Not IN C/Z/D	Character	Position	Not IN C/Z/D		Character	From	To	Control Level (L1-L9)	Matching Fields or Chaining Fields	Field Record Relation	Plus	Minus	Zero or Blank
01	I	INPUT	AA	ØL	1	CP													
02	I								2	4ØFLD1									
03	I								6	8ØFLD2									
04	I								1Ø	12ØFLD3									
05	I								14	16ØFLD4									
06	I								18	20ØFLD5									

### RPG CALCULATION SPECIFICATIONS

Form GX21-9093  
Printed in U.S.A.

Program _____ Programmer _____			Punching Instruction _____ Date _____			Graphic _____ Punch _____				Card Electro Number _____				Page 1 of 2	Program Identification 75 76 77 78 79 80				
-----------------------------------	--	--	--	--	--	------------------------------	--	--	--	---------------------------	--	--	--	-------------	--	--	--	--	--

Line	Form Type	Control Level (L0-L9) LF, SR, AN/DR	Indicators				Factor 1	Operation	Factor 2	Result Field		Resulting Indicators	Comments			
			And	And	Not	Not				Name	Length			Arithmetic		
														Plus	Minus	Zero
01	C		ØL				MOVE	FLD1	SET	1						
02	C		ØL				MOVE	FLD2	SET	2						
03	C		ØL				MOVE	FLD3	SET	3						
04	C		ØL				MOVE	FLD4	SET	4						
05	C		ØL				MOVE	FLD5	SET	5						

10. a. Output of 13th element of SET array:

### RPG OUTPUT SPECIFICATIONS

GX21-9090 U/M 050  
Printed in U.S.A.

Program _____ Programmer _____			Punching Instruction _____ Date _____			Graphic _____ Punch _____				Card Electro Number _____				Page 1 of 2	Program Identification 75 76 77 78 79 80				
-----------------------------------	--	--	--	--	--	------------------------------	--	--	--	---------------------------	--	--	--	-------------	--	--	--	--	--

Line	Form Type	Filename	Type (M/D/T/E)			Skip		Output Indicators				Field Name	End Position in Output Record	Constant or Edit Word
			Before	After	D	Before	After	Not	Not	Not	Not			
01	O	PRINT		D								*AUTO	ØL	
02	O											SET, 13		
03	O													27

Commas	Zero Balances to Print	No Sign	CR	-	X
Yes	Yes	1	A		Remove Plus Sign
Yes	No	2	B		Date
No	Yes	3	C		Field Edit
No	No	4	D		Zero Suppress

- b. Output of entire SET array at end of job since SET is an execution time array, must be done using output specifications, as shown below:

RPG OUTPUT SPECIFICATIONS															GX21-9090 U/M 0507 Printed in U.S.A.																		
Program					Punching Instruction					Graphic					Card Electro Number					Page 1 2 of		Program Identification 75 76 77 78 79 80											
Programmer					Date					Punch																							
Line	Form Type	Filename	Type (H/D/T/E)		Space		Skip		Output Indicators			Field Name	Edit Codes B/A/C/I/S/R	End Position in Output Record	P/B/L/R	Commas				Zero Balances to Print		No Sign		CR		-		X = Remove Plus Sign					
			Before	After	Before	After	Not	Not	Not	And	And					Yes	No	Yes	No	1	2	A	B	J	K	Y	Z	Date	Field Edit	Zero	Suppress		
0 1	O	PRINT	A	D																													
0 2	O																																
0 3	O																																

If SET were a compile time array or a pre-execution time array, output of the entire array could be accomplished by entering the output filename in To Filename (columns 19-26) in the extension specification for the array:

RPG EXTENSION AND LINE COUNTER SPECIFICATIONS															Form X21-9091 Printed in U.S.A.											
Program					Punching Instruction					Graphic					Card Electro Number					Page 1 2 of		Program Identification 75 76 77 78 79 80				
Programmer					Date					Punch																
Extension Specifications																										
Line	Form Type	Record Sequence of the Chaining File		To Filename	Table or Array Name	Number of Entries Per Record	Number of Entries Per Table or Array	Length of Entry	P/B/L/R	Decimal Positions Sequence (A/D)	Table or Array Name (Alternating Format)	Length of Entry	P/B/L/R	Decimal Positions Sequence (A/D)	Comments											
		From Filename	Number of the Chaining Field																							
0 1	E	*	IF COMPILE TIME:																							
0 2	E		PRINT	SET	15	15	3																			
0 3	E	*	IF PRE-EXECUTION TIME:																							
0 4	E		FROMFILEPRINT	SET	15	15	3																			
0 5	E																									

### RPG CALCULATION SPECIFICATIONS

Form GX21-9093  
Printed in U.S.A.

Program		Punching Instruction		Graphic		Card Electro Number		Page 1 2 of		Program Identification 75 76 77 78 79 80	
Programmer		Date		Punch							

Line	Form Type	Control Level (L, O, L, L, R, SR, AN, OR)	Indicators			Factor 1	Operation	Factor 2	Result Field		Resulting Indicators			Comments
			And	And	Not				Name	Length	Plus	Minus	Zero	
01	C						Z-ADD		IX					
02	C				AGAIN	TAG								
03	C				SEARCH	LOKUPPAY, IX								23 FOUND, 23 ON
04	C		23			EXCPT								
05	C		23		IX	ADD 1			IX					
06	C		23		IX	COMP 7								
07	C		24	23		GOTO AGAIN								24

### RPG OUTPUT SPECIFICATIONS

Form GX21-9090 U/M 050\*  
Printed in U.S.A.

Program		Punching Instruction		Graphic		Card Electro Number		Page 1 2 of		Program Identification 75 76 77 78 79 80	
Programmer		Date		Punch							

Line	Form Type	Filename	Output Indicators			Field Name	End Position in Output Record	Constant or Edit Word
			And	And	Not			
01	O	PRINT			23			
02	O					IX	5	
03	O					PAY, IX	74	

Commas	Zero Balances to Print	No Sign	CR	-	X = Remove Plus Sign
Yes	Yes	1	A	J	Y = Date Field Edit
Yes	No	2	S	K	Z = Zero Suppress
No	Yes	3	C	L	
No	No	4	O	M	



### RPG CALCULATION SPECIFICATIONS

Form GX21-9083  
Printed in U.S.A.

Program		Punching Instruction		Graphic		Card Electro Number		Page 1 2 of ___		Program Identification 75 76 77 78 79 80	
Programmer		Date		Punch							

Line	Form Type	Control Level (LD-L9, LR, SR, AM/OR)	Indicators			Factor 1	Operation	Factor 2	Result Field		Resulting Indicators	Comments
			Not	And	And				Name	Length		
01	C					ARAL	ADD	ARA2	ARA2			
02	C					XFOOTAR		ARA2	TOTAL	BZ		
03	C											

### RPG OUTPUT SPECIFICATIONS

Form GX21-9090 U/M 090\*  
Printed in U.S.A.

Program		Punching Instruction		Graphic		Card Electro Number		Page 1 2 of ___		Program Identification 75 76 77 78 79 80	
Programmer		Date		Punch							

Line	Form Type	Filename	Type (M/D/E)		Space	Skip	Output Indicators			Field Name	End Position in Output Record	P/B/L/R	Constant or Edit Word
			Shaded # (Facid/F)	Before			After	Not	And				
01	O	PRINT	A	D						*AUTO			
02	O									ARA2		63	
03	O									TOTAL		84	
04	O												

Commas	Zero Balances to Print	No Sign	CR	-	X = Remove Plus Sign
Yes	Yes	1	A	J	Y = Date
Yes	No	2	B	K	Field Edit
No	Yes	3	C	L	Z = Zero Suppress
No	No	4	D	M	

**CHAPTER 10 DESCRIBES:**

Representation of characters on cards.

Representation of characters in storage (disk and inside the computer).

Packed and binary data.

Collating sequence of characters.

Move zone operations.

File translation.

**AFTER READING THIS CHAPTER YOU SHOULD BE ABLE TO:**

Describe the representation of characters and negative numbers on cards.

Describe the representation of characters on disk and inside the computer.

Define byte, bit, zone portion and digit portion.

Compare the storing of characters on cards to the storing of characters in storage.

Identify bit combinations with numerical values.

Assign numerical values to zone and digit portions.

Define unpacked decimal format, packed decimal format, and binary format.

Describe the hexadecimal numbering system.

Describe the collating sequence of characters.

Code specifications to change the collating sequence.

Alter the structure of characters in storage by using move zone operations.

Translate characters by coding the Translation Table and Alternate Collating Sheet.

*Note:* You can use the review questions contained in **Review 10** at the end of this chapter to test your comprehension of each topic in the chapter. Questions are grouped according to the topic to which they apply. Answers follow the review questions.

# CHARACTER STRUCTURE

## Representation of Characters on 96-Column Cards

Punched cards provide data the computer is to work with. Each of the 96 columns of a card can contain punches for a single character. Therefore, up to 96 characters of information can be represented on a single record.

Each column of a card consists of six punch positions, labeled *B*, *A*, *8*, *4*, *2*, and *1*, from the top of a column to the bottom. Characters are represented by a combination of from zero to six holes punched in the punch positions of a single column.

Since there are six punch positions available, the number and positions of the holes may be varied to form 64 different punch combinations. Each unique combination of punches is associated with a particular character. Therefore, you can represent any one of 64 different characters in a card column (Figure 10-1).

A card column consists of both a zone portion and a digit portion. *B* and *A* are referred to as zone punch positions, while *8*, *4*, *2*, and *1* are digit punch positions. The combinations of zone and digit punches make it possible to separate the characters into three groups (Figure 10-1):

- Alphabetic letters are represented by at least one punch in both the zone and digit portions of a column.
- The 28 special characters can consist of no punches, only zone punches, only digit punches, or both zone and digit punches.
- Positive numbers are represented by holes only in the digit punch positions. The one exception is the number 0 which is represented by a single punch in the *A* zone punch position.

			Numeric Characters											
			0	1	2	3	4	5	6	7	8	9		
Punch Positions	Zone	B												
		A	A											
	Digit	8										8	8	
		4					4	4	4	4				
		2			2	2				2	2			
		1		1		1			1			1		1

			Alphabetic Characters																										
			A	B	C	D	E	F	G	H	I	J	K	L	M	N	O	P	Q	R	S	T	U	V	W	X	Y	Z	
Punch Positions	Zone	B	B	B	B	B	B	B	B	B	B	B	B	B	B	B	B	B	B										
		A	A	A	A	A	A	A	A	A	A											A	A	A	A	A	A	A	A
	Digit	8									8	8									8	8						8	8
		4					4	4	4	4					4	4	4	4					4	4	4	4			
		2			2	2				2	2				2	2				2	2			2	2			2	2
		1		1		1			1			1	1		1			1		1		1		1		1		1	

			Special Characters																													
			}	¢	.	<	(	+		!	\$	*	)	;	¬	-	/	&	,	%	-	>	?	:	#	@	'	=	"	¸		
Punch Positions	Zone	B	B	B	B	B	B	B	B	B	B	B	B	B	B	B	B															
		A	A	A	A	A	A	A	A												A	A	A	A	A	A						
	Digit	8			8	8	8	8	8	8	8	8	8	8	8	8					8	8	8	8	8	8	8	8	8	8		
		4					4	4	4	4					4	4	4	4					4	4	4	4			4	4	4	4
		2			2	2				2	2	2	2			2	2				2	2			2	2	2	2			2	2
1				1		1			1			1		1			1		1		1		1		1		1		1			

51708

Figure 10-1. Character Set and Punch Combinations

## Representation of Negative Numbers

## CHARACTERS

Note that *positive* numbers are represented only by digit punches. Negative numbers (-1 through -9 and -0) can also be represented to the computer. However, to indicate that a number is negative, a column must contain both the punch combination for the number and the punch combination for the minus sign. As column 7 of Figure 10-2 shows, the 8 and 1 digit-punch positions are punched to represent the number 9. A -9 is represented in column 12 by the same digit punches plus a hole in the B zone-punch position.

		CHARACTERS									
		-1	-2	-3	-4	-5	-6	-7	-8	-9	-0
Punch Position	B	•	•	•	•	•	•	•	•	•	•
	A										•
	8								•	•	
	4				•	•	•	•			
	2		•	•			•	•			
1	•		•		•		•		•		
		J	K	L	M	N	O	P	Q	R	
Punch Position	B	•	•	•	•	•	•	•	•	•	•
	A										•
	8								•	•	
	4				•	•	•	•			
	2		•	•			•	•			
1	•		•		•		•		•		

As mentioned, all 64 possible punch combinations are associated with a character. Therefore, adding a B zone punch to the punch combination of a number means the punch combination for any negative number is the same as the punch combination already assigned to one of the 64 characters. The negative numbers -1 through -9 are represented by the same punch combinations as the letters J through R; -0 has the same punch combination as the special character }

*Note:* Although the value -0 (negative zero) is not used by itself, it can exist as a punch combination in the units position of a data field.

The RPG II program determines whether the punch combination is a letter or a number according to whether an entry has been made in column 52 of the input specifications. Column 52 is used to specify the number of decimal positions in a field. If an entry is present, the RPG II program assumes any character in that field to be numeric. Absence of an entry in column 52 tells the RPG II program that it is reading either a letter or a special character in an

● Figure 10-3. Negative Number Punch Combinations the Same as Punch Combinations for J-R

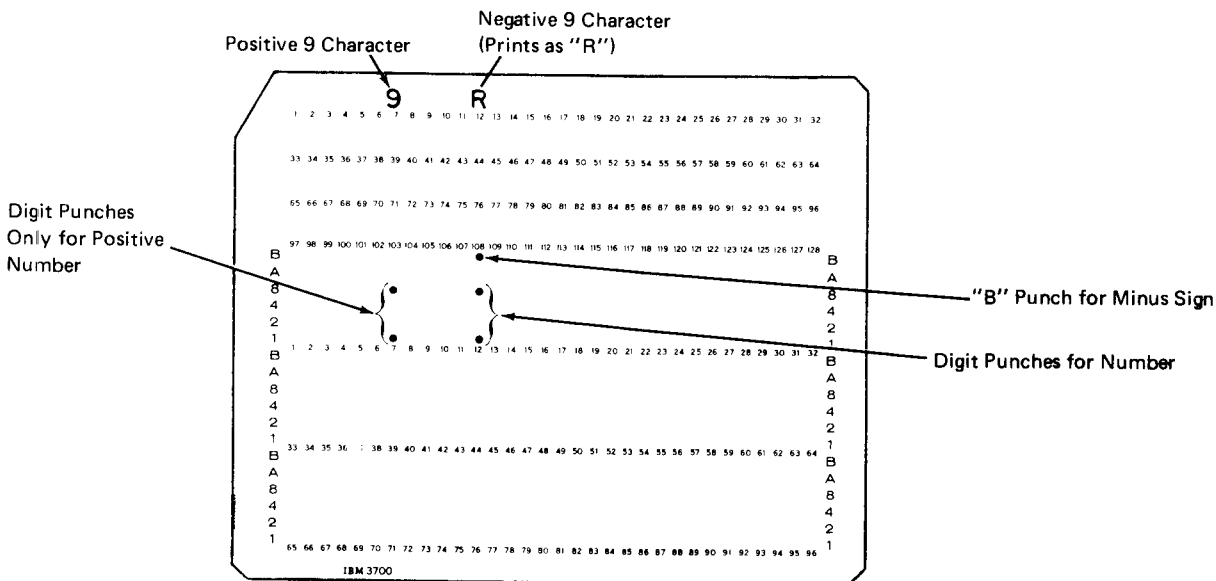

Figure 10-2. Punches for Negative Numbers

alphanumeric field. By examining column 52, the RPG II program recognizes when the B zone punch is associated with the punch combination of one of the letters J through R or the punch combination of a negative number.

In the discussion so far, you have learned how data is recorded in a form which the computer can understand. The data is represented as punched holes on 96-column cards. Before the RPG II program can use the data, as in calculations or output operations, it must store the information. The data is then available in computer storage whenever it is needed during the run of a program.

### Representation of Characters in Storage

When you look at the punch area of a card, you cannot immediately determine which characters are stored on the card. First, you have to determine which character is associated with a particular punch combination. The punched holes, then, are the means of representing characters on a card. Similarly, a character such as the letter A is not stored on disk or inside the computer in a form you would recognize as the letter A. On disk or inside the computer, there is also a means of representing characters.

Information from each of the 96 columns of punched cards can be transferred to disk. Data from each column is stored in corresponding positions on disk in the form of magnetized spots.

Characters are represented electronically in computer storage. The storage area of the computer consists of a number of magnetic bits, which can be turned on or off by passing an electric current through them. The exact details of how this is done is not important to this discussion; what is important is that each bit can be in either an on state or an off state. We use a 1 to show a bit that is on; while a 0 represents a bit that is off (Figure 10-4).

The magnetic bits inside the computer or on disk are arranged in groups, called bytes, just as the punch positions on a card are arranged in groups called columns (Figure 10-4). Just as each column on a card can contain a character, each byte in storage can also contain a character. A particular combination of on and off bits in a byte represent a certain character inside the computer, just as a particular combination of punched and unpunched positions in a column represent that character on a card.

Data is represented on a card, character by character; likewise, data is stored inside the computer, character by character. Just as you can look at a punched card and refer to a character by the particular column containing that character's punch combination, the computer can reference a character by the particular byte in storage which contains that character's bit combination.

### Difference Between Character Representation on Cards and in Storage

Although there are many similarities in the way a character is represented in storage and on a punched card, it is important to note one difference. While a card column consists of six positions, a byte consists of eight positions or bits. Thus, within the computer, eight positions are used to represent a single character, whereas only six positions are available on a card.

A byte is divided into a zone portion and a digit portion, just as a card column is (Figure 10-5). The four digit positions, in both a byte and a column, are labeled 1, 2, 4, and 8. However, a byte contains four zone positions, whereas a card column contains only two zone positions.

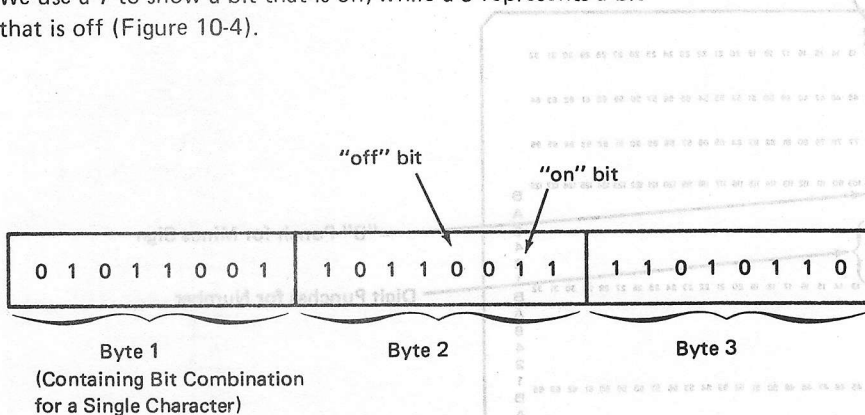

Figure 10-4. Representation of Characters in Storage

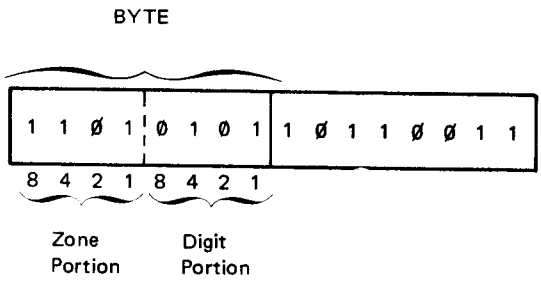
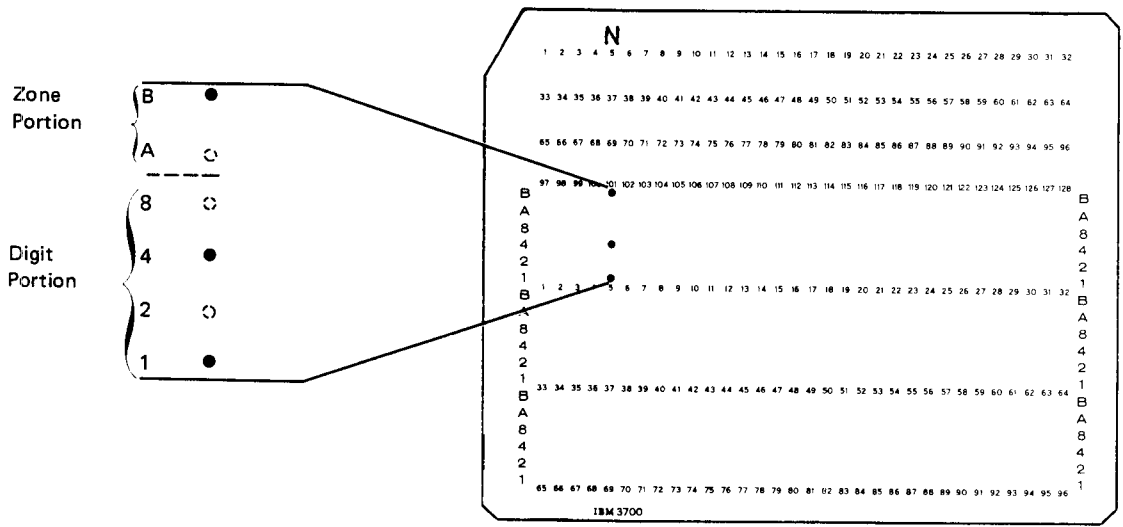

Figure 10-5. Correspondence Between a Byte and a Card Column

Since there are four digit positions in both a byte and a card column, the digit portion of a byte corresponds one-for-one with the digit portion of that character's punch combination. That is, if a digit punch position is punched, the corresponding digit bit is set on (1) in storage. Likewise a digit bit is set off (0) if the corresponding punch position does not contain a punch. To check this, note how the digit portion of the plus sign (+) character is represented on a card and in storage (Figure 10-6). (Note: Ampersand (&) is an exception to this rule; see Figure 10-7.)

The zone portions of a card column and a byte do not correspond one-to-one, however. This is because there are four zone bits in storage for each character, while there are only two zone positions in a card column. Looking at Figure 10-6 again, you can see that even though A and B punch positions contain punches for the plus sign character, the 2 and 1 zone bits in storage are not on.

Since the zone portions differ, a translation takes place when a card is read and the data (characters) is stored inside the computer. The machine reads the punch combination on the card and electronically produces the appropriate bit combinations in storage. Such translations (shown in Figure 10-7) are automatic; therefore, you need not be concerned with how the computer knows which bits to turn on and off.

When programming in RPG II, however, you do have to be concerned with zones and digits as they are represented inside the computer. The division of the card column into zone and digit portions is only for convenience.

On the Input sheet, you can specify record identification codes. If you choose to use only the zone portion of a character, you will be using the zone positions as they are in storage. Assume that a record identification code with

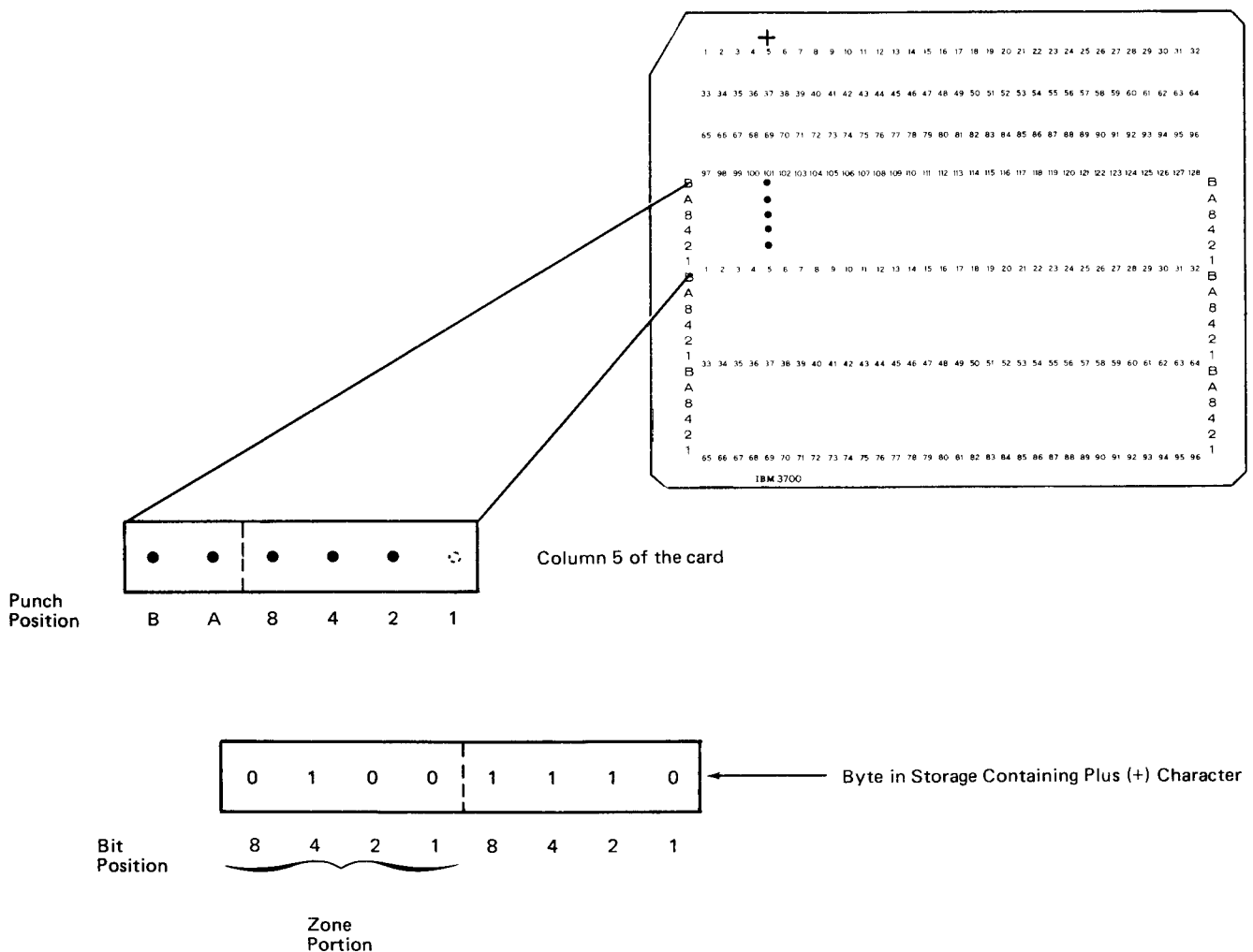

Figure 10-6. Similarity in Digit Portion of Byte and Card Column

Character	Punch Combination						Bit Combination	
	Zone			Digit			Zone	Digit
	B	A	8	4	2	1		
␣ (blank)							0100	0000
¢	•	•	•		•		0100	1010
. (period)	•	•	•		•	•	0100	1011
<	•	•	•	•			0100	1100
(	•	•	•	•		•	0100	1101
+	•	•	•	•	•		0100	1110
	•	•	•	•	•	•	0100	1111
&		•	•		•		0101	0000
!	•		•		•		0101	1010
\$	•		•		•	•	0101	1011
*	•		•	•			0101	1100
)	•		•	•		•	0101	1101
;	•		•	•	•		0101	1110
⌋	•		•	•	•	•	0101	1111
- (minus)	•						0110	0000
/		•				•	0110	0001
,		•	•		•	•	0110	1011
%		•	•	•			0110	1100
_ (underscore)		•	•	•		•	0110	1101
>		•	•	•	•		0110	1110
?		•	•	•	•	•	0110	1111
:			•		•		0111	1010
#			•		•	•	0111	1011
@			•	•			0111	1100
' (apostrophe)			•	•		•	0111	1101
=			•	•	•		0111	1110
"			•	•	•	•	0111	1111

Character	Punch Combination						Bit Combination	
	Zone			Digit			Zone	Digit
	B	A	8	4	2	1		
A	•	•				•	1100	0001
B	•	•			•		1100	0010
C	•	•			•	•	1100	0011
D	•	•		•			1100	0100
E	•	•		•		•	1100	0101
F	•	•		•	•		1100	0110
G	•	•		•	•	•	1100	0111
H	•	•	•				1100	1000
I	•	•	•			•	1100	1001
} or -0	•	•					1101	0000
J or -1	•					•	1101	0001
K or -2	•				•		1101	0010
L or -3	•				•	•	1101	0011
M or -4	•			•			1101	0100
N or -5	•			•		•	1101	0101
O or -6	•			•	•		1101	0110
P or -7	•			•	•	•	1101	0111
Q or -8	•		•				1101	1000
R or -9	•		•			•	1101	1001
S		•			•		1110	0010
T		•			•	•	1110	0011
U		•		•			1110	0100
V		•		•		•	1110	0101
W		•		•	•		1110	0110
X		•		•	•	•	1110	0111
Y		•	•				1110	1000
Z		•	•			•	1110	1001
+0		•					1111	0000
1						•	1111	0001
2					•		1111	0010
3					•	•	1111	0011
4				•			1111	0100
5				•		•	1111	0101
6				•	•		1111	0110
7				•	•	•	1111	0111
8			•				1111	1000
9			•			•	1111	1001

Figure 10-7. Bit and Punch Combinations for Characters



the zone of a \$ character in column 1 is to turn on resulting indicator 21. If an input record is read with the character J in column 1, indicator 21 will not turn on. Even though the card zone punches for \$ and J are the same (both have the B zone punched), the bit combinations in storage for the \$ and J do not have identical zone portions (Figure 10-8).

ZONE PORTIONS OF CARD

ZONE PORTIONS IN STORAGE

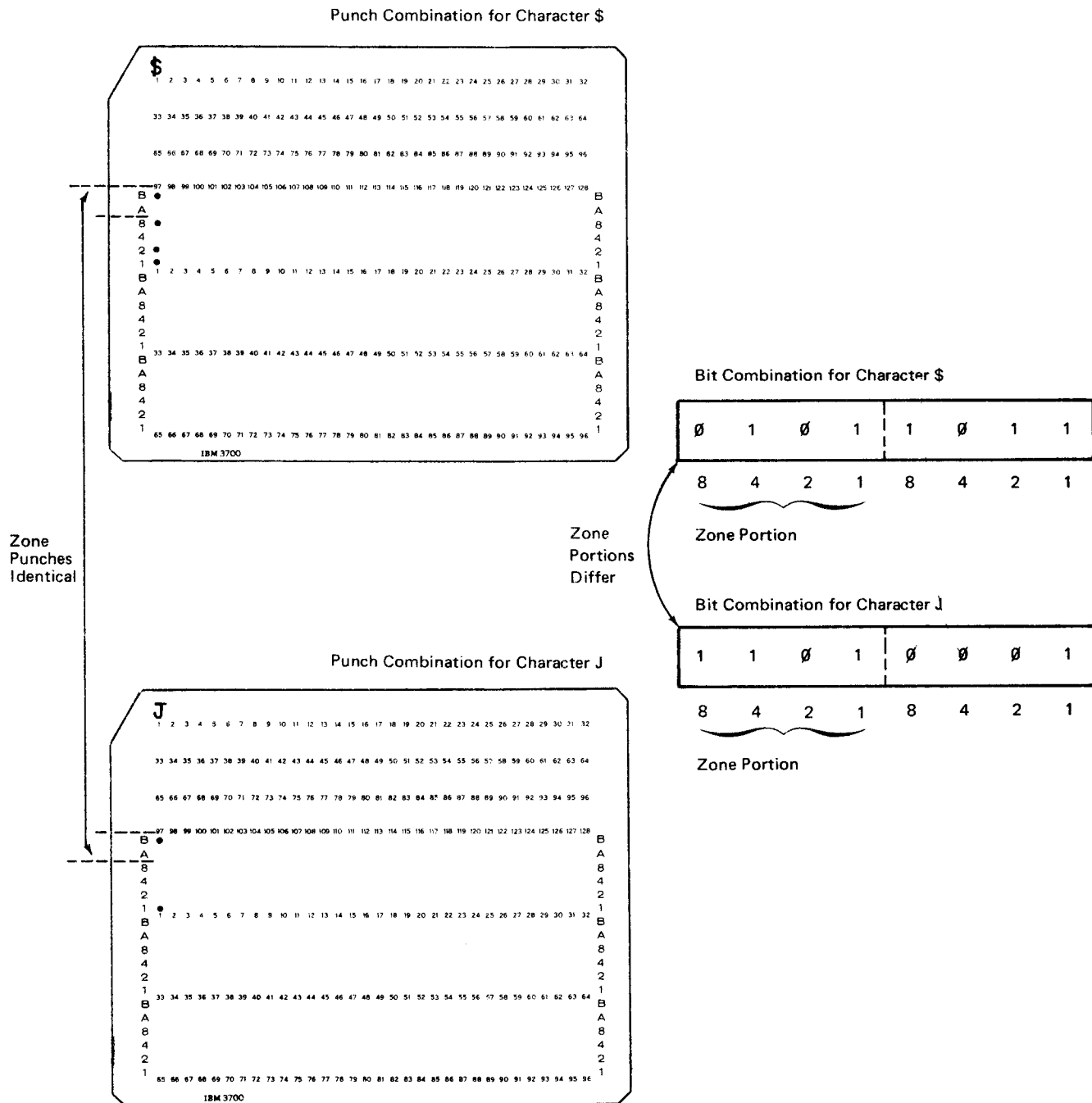
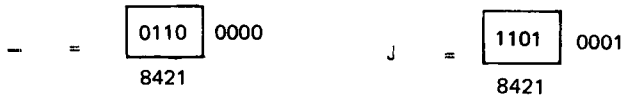

Figure 10-8. Difference in Zone Portions of a Byte and a Card Column

There are exceptions which should be noted in specifying that the zones of characters be used to identify records. According to Figure 10-9, the zone of the letter J is used to identify record type 01, while the zone of a minus sign is used to identify record type 02. Recorded on cards, both characters have a B zone punch. However, inside the computer, their zone representations differ.



Although the zones differ, the RPG II program considers the two the same. Thus, a card with a minus punched might turn on either the 01 or 02 indicator. Likewise, a card with the letter J could turn on either indicator.

Similarly, the zone of the character *blank* is treated the same as the zone of 0 through 9. Also, the zone of & (ampersand) is treated the same as the zones of the letters A through I. To avoid confusion, you should not specify both (zones of the characters J and -; blank and 0-9; & and A-I) for identification of record types which are to be used in the same program.

Figure 10-10 shows the groups of characters that have zones that test as equal for purposes of record identification and the TESTZ operation. Notice that these groupings are different from the groupings of characters for purposes of collating sequence by zone (Figure 10-28).

RPG INPUT																																			
IBM International Business Machine Corporation															Punching Instruction		Graphic																		
Program					Date					Punch																									
Record Identification Codes															1		2																		
Line	Form Type	Filename	Sequence				Number (I, N)	Option (O)	Record Identifying Indicator or **	Position		Position			Position																				
			O	R	A	D				Not (N)	C/Z/D	Character	Position	Not (N)	C/Z/D	Character	Position																		
3	4	5	6	7	8	9	10	11	12	13	14	15	16	17	18	19	20	21	22	23	24	25	26	27	28	29	30	31	32	33	34	35	36	37	
0 1	I	FILEA																																	
0 2	I	*																																	
0 3	I																																		
0 4	I																																		
0 5	I																																		
0 6	I																																		

Figure 10-9. Exception: Zone Representation Considered the Same

Character	Bit Combination		Collating Sequence of Zones
	Zone	Digit	
¢	0100	1010	1
· (period)	0100	1011	
<	0100	1100	
{	0100	1101	
+	0100	1110	
	0100	1111	
!	0101	1010	2
\$	0101	1011	
*	0101	1100	
}	0101	1101	
;	0101	1110	
⌋	0101	1111	
/	0110	0001	3
,	0110	1011	
%	0110	1100	
_ (underscore)	0110	1101	
>	0110	1110	
?	0110	1111	
:	0111	1010	4
#	0111	1011	
@	0111	1100	
' (apostrophe)	0111	1101	
=	0111	1110	
"	0111	1111	
&	0101	0000	5
A	1100	0001	
B	1100	0010	
C	1100	0011	
D	1100	0100	
E	1100	0101	
F	1100	0110	
G	1100	0111	
H	1100	1000	
I	1100	1001	

Character	Bit Combination		Collating Sequence of Zones
	Zone	Digit	
(minus)	0110	0000	6
}	1101	0000	
J or -1	1101	0001	
K or -2	1101	0010	
L or -3	1101	0011	
M or -4	1101	0100	
N or -5	1101	0101	
O or -6	1101	0110	
P or -7	1101	0111	
Q or -8	1101	1000	
R or -9	1101	1001	
S	1110	0010	7
T	1110	0011	
U	1110	0100	
V	1110	0101	
W	1110	0110	
X	1110	0111	
Y	1110	1000	
Z	1110	1001	
b (blank)	0100	0000	8
+0	1111	0000	
1	1111	0001	
2	1111	0010	
3	1111	0011	
4	1111	0100	
5	1111	0101	
6	1111	0110	
7	1111	0111	
8	1111	1000	
9	1111	1001	

Figure 10-10. Character Groups With Zones that Test as Equal for Record ID and TESTZ

Consider another example which points out the difference in how negative numbers are stored and how you may think they are stored. The minus sign alone is represented on a card and in storage as shown in Figure 10-11, insert A. Only the zone portion of the card contains a punch. Figure 10-11, insert B, shows how a positive 5 is represented on a card and in storage. In this case, only the digit portion of the card contains punches. Note Figure 10-11, insert C, for the punch and bit combinations which represent a -5.

When checking the cards you can see that the digit punches for the positive 5 and the negative 5 are the same. Furthermore, the digit bits in storage for the two characters are also the same. The zone punch for -5 is the same as the zone punch for the minus sign character. However, the zone bits in storage for the two characters are not the same. Therefore, you should not always assume that, in storage, the zone bits for a negative number would be identical to the zone bits for the minus sign (Figure 10-11).

The reason is that the computer checks the *entire* punch combination (both zone and digit portions) of a column to determine which *zone* bits are to be on or off. Since the entire punch combinations (not only zone punches) for the minus character and the negative 5 are different, their zone bits in storage are also different.

A conclusion can be drawn from the previous examples: each unique punch combination is associated with a different bit combination. Of course, in discussing negative numbers before, we stated that the punch combinations of -1 through -9 and -0 are the same as the punches for the letters J through R and  $\{$ . Thus, the bit combinations for the negative numbers are also the same as those for J through R.

Consider again the number of positions available to represent a character. A characteristic of codes involving different combinations (such as bits on and off or punches) is that the greater the number of positions available to represent any one combination, the greater the number of combinations that are possible. As mentioned, with six punch positions, 64 unique punch combinations can be made, and, therefore, 64 different characters can be represented on a card. With eight bits (positions), 256 unique combinations of on-off bits can be created and, therefore, 256 different characters could be represented inside the computer. However, you only need 64 characters to program the computer; therefore, only 64 of its 256 bit combinations are associated with a printable character.

Representation of Minus (-) Character

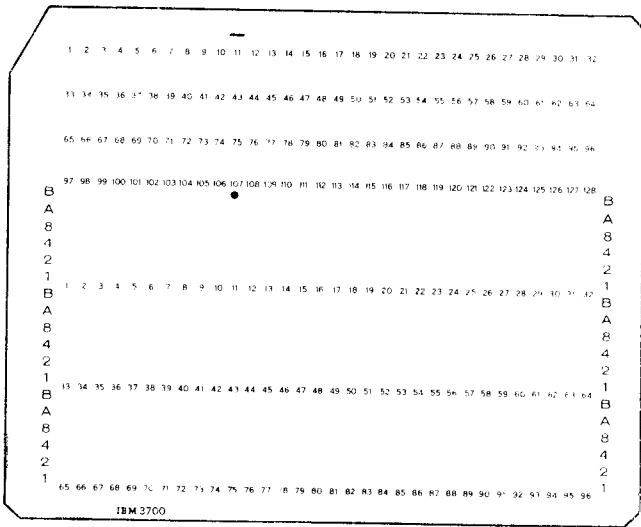

(A)

BIT 8 4 2 1 8 4 2 1

Representation of "5" Character (Positive)

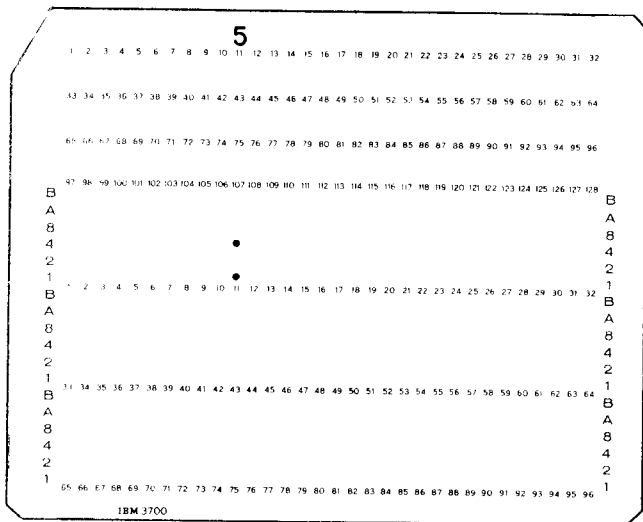

(B)

8 4 2 1 8 4 2 1

Representation of "-5" Character (Negative)

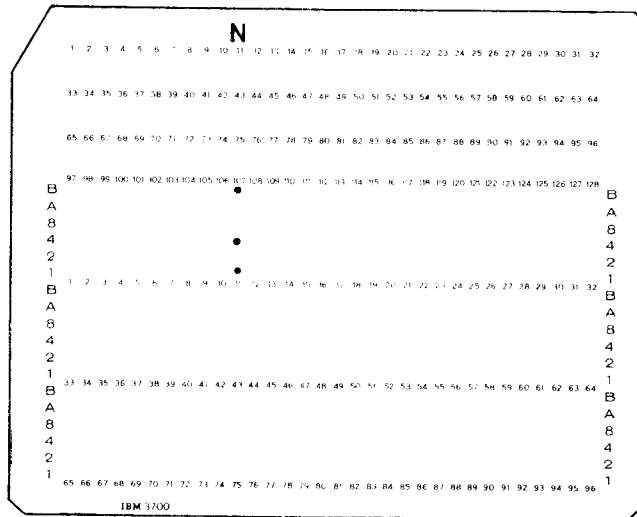

(C)

BIT 8 4 2 1 8 4 2 1

Figure 10-11. Representation of a Negative Number

## Identifying Bit Combinations with Numerical Values

Each unique combination of eight bits can be associated with a numerical value. Before discussing how the numerical value is determined for a character, perhaps first you would like to know why numerical values are assigned.

As mentioned before, data can be represented on punched cards. Actually, after reading a card, the computer does not immediately determine what character is punched. It can, however, distinguish one punch combination from another punch combination. Furthermore, the particular combination of punches indicates to the computer which bits should be set on and off to represent that punch combination inside the machine. At this point, the representation on the card is just a particular group of punches and the representation in storage is merely a particular combination of on and off bits.

To use the byte of data for output, the computer must know what character to punch or print. This is done by associating a numerical value with each unique bit combination. The computer automatically knows that a certain value is related to a particular character, such as the value 209 indicates the character *J*.

Consider how a numerical value and how the character are determined. Each of the eight bits in a byte are assigned a number. The values begin with 1 for the 1 bit and are doubled for each of the next bits (Figure 10-12). By adding only the numbers which correspond to bits which are on (1), a numerical value is obtained for a byte. As Figure 10-12 shows, first the punch combination (for the character *F*) in column 7 is translated into the bit combination in storage. The bits *on* result in a numerical value of 198, which the computer associates with the character *F*.

Any difference in the bit combination results in a difference in numerical value. Therefore, every character is associated with a different numerical value. The greatest numerical value which can be associated with a bit combination is 255 (all eight bits on), while the lowest numerical value is 0 (all eight bits off). This results in a total of 256 possible numerical values. Only 64 different characters can be represented on a 96 column card; therefore, we are concerned with only 64 of the different numerical values. However, as Figure 10-13 shows, the 64 numerical values associated with the characters can range anywhere from 0 through 255. The numerical values missing from the chart are not related to any printable character.

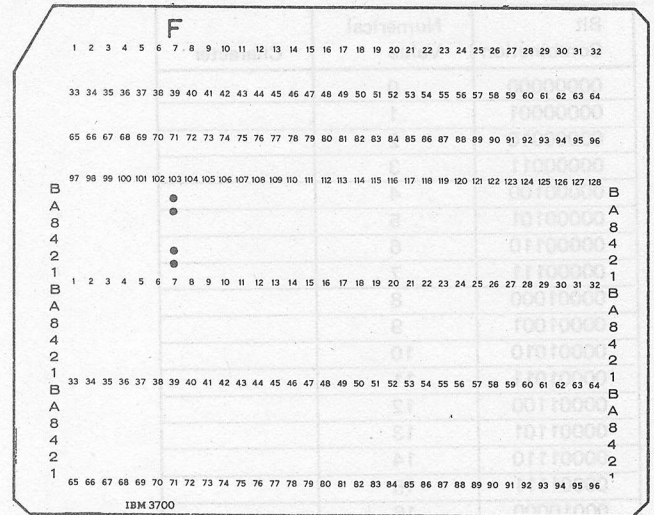

One Byte in Storage

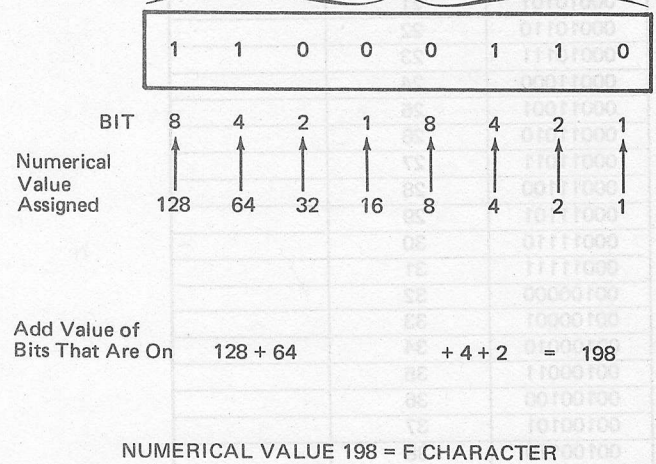

Figure 10-12. Determining a Numerical Value for a Character

Bit Combination	Numerical Value	Character
00000000	0	
00000001	1	
00000010	2	
00000011	3	
00000100	4	
00000101	5	
00000110	6	
00000111	7	
00001000	8	
00001001	9	
00001010	10	
00001011	11	
00001100	12	
00001101	13	
00001110	14	
00001111	15	
00010000	16	
00010001	17	
00010010	18	
00010011	19	
00010100	20	
00010101	21	
00010110	22	
00010111	23	
00011000	24	
00011001	25	
00011010	26	
00011011	27	
00011100	28	
00011101	29	
00011110	30	
00011111	31	
00100000	32	
00100001	33	
00100010	34	
00100011	35	
00100100	36	
00100101	37	
00100110	38	
00100111	39	
00101000	40	
00101001	41	
00101010	42	
00101011	43	
00101100	44	
00101101	45	
00101110	46	
00101111	47	
00110000	48	
00110001	49	
00110010	50	

Bit Combination	Numerical Value	Character
00110011	51	
00110100	52	
00110101	53	
00110110	54	
00110111	55	
00111000	56	
00111001	57	
00111010	58	
00111011	59	
00111100	60	
00111101	61	
00111110	62	
00111111	63	
01000000	64	Blank
01000001	65	
01000010	66	
01000011	67	
01000100	68	
01000101	69	
01000110	70	
01000111	71	
01001000	72	
01001001	72	
01001010	74	¢
01001011	75	.
01001100	76	<
01001101	77	(
01001110	78	+
01001111	79	
01010000	80	&
01010001	81	
01010010	82	
01010011	83	
01010100	84	
01010101	85	
01010110	86	
01010111	87	
01011000	88	
01011001	89	
01011010	90	!
01011011	91	\$
01011100	92	*
01011101	93	)
01011110	94	;
01011111	95	⌋
01100000	96	-
01100001	97	/
01100010	98	
01100011	99	
01100100	100	
01100101	101	

Figure 10-13 (Part 1 of 3). Numerical Values Associated with Characters

Bit Combination	Numerical Value	Character
01100110	102	
01100111	103	
01101000	104	
01101001	105	
01101010	106	
01101011	107	,
01101100	108	%
01101101	109	-
01101110	110	>
01101111	111	?
01110000	112	
01110001	113	
01110010	114	
01110011	115	
01110100	116	
01110101	117	
01110110	118	
01110111	119	
01111000	120	
01111001	121	
01111010	122	:
01111011	123	#
01111100	124	@
01111101	125	'
01111110	126	=
01111111	127	"
10000000	128	
10000001	129	
10000010	130	
10000011	131	
10000100	132	
10000101	133	
10000110	134	
10000111	135	
10001000	136	
10001001	137	
10001010	138	
10001011	139	
10001100	140	
10001101	141	
10001110	142	
10001111	143	
10010000	144	
10010001	145	
10010010	146	
10010011	147	
10010100	148	
10010101	149	
10010110	150	
10010111	151	
10011000	152	

Bit Combination	Numerical Value	Character
10011001	153	
10011010	154	
10011011	155	
10011100	156	
10011101	157	
10011110	158	
10011111	159	
10100000	160	
10100001	161	
10100010	162	
10100011	163	
10100100	164	
10100101	165	
10100110	166	
10100111	167	
10101000	168	
10101001	169	
10101010	170	
10101011	171	
10101100	172	
10101101	173	
10101110	174	
10101111	175	
10110000	176	
10110001	177	
10110010	178	
10110011	179	
10110100	180	
10110101	181	
10110110	182	
10110111	183	
10111000	184	
10111001	185	
10111010	186	
10111011	187	
10111100	188	
10111101	189	
10111110	190	
10111111	191	
11000000	192	
11000001	193	A
11000010	194	B
11000011	195	C
11000100	196	D
11000101	197	E
11000110	198	F
11000111	199	G
11001000	200	H
11001001	201	I
11001010	202	
11001011	203	

Figure 10-13 (Part 2 of 3). Numerical Values Associated with Characters



Bit Combination	Numerical Value	Character
11001100	204	
11001101	205	
11001110	206	
11001111	207	
11010000	208	} or -0
11010001	209	J or -1
11010010	210	K or -2
11010011	211	L or -3
11010100	212	M or -4
11010101	213	N or -5
11010110	214	O or -6
11010111	215	P or -7
11011000	216	Q or -8
11011001	217	R or -9
11011010	218	
11011011	219	
11011100	220	
11011101	221	
11011110	222	
11011111	223	
11100000	224	
11100001	225	
11100010	226	S
11100011	227	T
11100100	228	U
11100101	229	V
11100110	230	W
11100111	231	X
11101000	232	Y
11101001	233	Z
11101010	234	
11101011	235	
11101100	236	
11101101	237	
11101110	238	
11101111	239	
11110000	240	0
11110001	241	1
11110010	242	2
11110011	243	3
11110100	244	4
11110101	245	5
11110110	246	6
11110111	247	7
11111000	248	8
11111001	249	9
11111010	250	
11111011	251	
11111100	252	
11111101	253	
11111110	254	
11111111	255	

Figure 10-13 (Part 3 of 3). Numerical Values Associated with Characters

### Assigning Numerical Values to Zone and Digit Portions

You have seen how a single numerical value is determined for a combination of eight bits. The numerical value of a character in storage can also be expressed as a pair of numbers, rather than a single value. One number designates the value of only the four zone bits; the other number represents the value of the four digit bits.

You may be wondering why a character would ever be associated with two paired numbers, since it can be associated with just a single number. In certain jobs, you may be concerned with only the digit portion or only the zone portion of a character. For example, if records within a group are to be sequence checked only on the basis of the zone of a character, the computer must look at only the zone bits and determine a numerical value for the zone portion alone in order to make the comparison. Also, if you want to alter the collating sequence or translate a file, both to be discussed later, you must know the separate values for the zone and digit portions of a character.

Determining separate zone and digit values is similar to determining a single value for an entire bit combination; that is, values are assigned to each of the bit positions. The values which correspond to *on* bits (1) are then added to obtain a value.

To determine separate values, the zone and digit portions are each treated as separate 4-bit combinations. The four bits in each portion are assigned the values 1, 2, 4, and 8 (Figure 10-14). The rightmost zone and digit bits each have the value 1; while the leftmost bits in each portion are assigned the value 8. A value for the zone portion of a byte is determined by adding only the values corresponding to zone bits which are on (1). Likewise, a digit value is obtained by considering only digit bits which are on.

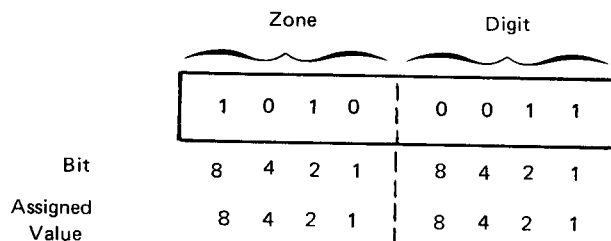

Figure 10-14. Assigning Values for Zone and Digit Portions of a Character

As Figure 10-15, insert A, shows, the bit combination for the slash (/) character produces a zone value of 6 and a digit value of 1. Putting the two values together, the entire character can be expressed as the value 61. Note, however, that this is not the same as the numerical value 61 in our decimal numbering system. If we were to determine a numerical value for the *entire* 8-bit combination, we would obtain the value 97 (Figure 10-15, insert B).

As mentioned before, with eight bits or positions in a byte, 256 different 8-bit combinations can be formed. The 256 combinations can be associated with the numerical values 0-255 (Figure 10-16, insert A). If either the zone or digit portion are considered separately, however, only four bits or positions are available. Therefore, a maximum of 16 different 4-bit combinations can be represented in either the zone or digit portion of a byte. The 16 zone or digit combinations can be associated with the values 0 through 15 (Figure 10-16, insert B).

The value obtained for a zone or digit bit combination is referred to as *hexadecimal* number. Hex means 6, while decimal refers to 10. Hexadecimal, then, means 6 + 10, or 16. A hexadecimal number can be any one of 16 possible

values (0-15). Putting the two hexadecimal numbers for the zone and digit portions together gives a hexadecimal value for the entire character. 61 is the hexadecimal value for the / character. Keep in mind that this hexadecimal value is actually two separate values, one for the zone and one for the digit portion.

All of the 256 possible 8-bit combinations can be represented by a hexadecimal value; that is, two hexadecimal numbers. However, each hexadecimal number can take up only one position. If a zone portion has the value 15 and a digit portion has the value 12, the hexadecimal value for the character cannot be expressed as 1512. Consequently, a zone or digit portion whose numerical value is 10 or greater (2-position number) must be represented in a slightly different form. This is done by assigning a single letter as a substitute for the number. The letters A through F serve as the hexadecimal forms of the values 10 through 15 as shown in Figure 10-17.

**VALUE BY ZONE AND DIGIT**

	Zone				Digit			
Bit Combination for "/" Character	0	1	1	0	0	0	0	1
Bit	8	4	2	1	8	4	2	1
Values For "ON" Bits	4 + 2				+ 1			
<b>(A)</b>	Zone Value 6				Digit Value 1			

**VALUE FOR ENTIRE BIT COMBINATION**

Bit Combination For "/" Character	0	1	1	0	0	0	0	1
Bit	8	4	2	1	8	4	2	1
Values For "ON" Bits	64 + 32				+ 1			
<b>(B)</b>	Value 97							

Figure 10-15. Difference in Value of Entire Character and Value of Zone and Digit Portions of Character

**(A) DETERMINING NUMERICAL VALUE FOR ENTIRE BYTE**

	1 1 1 1				1 1 1 1			
Bit	8	4	2	1	8	4	2	1
Value Assigned To Bit	128	64	32	16	8	4	2	1
Maximum Numerical Value	128 + 64 + 32 + 16				+ 8 + 4 + 2 + 1 = 255			

---

**(B) DETERMINING NUMERICAL VALUE FOR ZONE OR DIGIT**

	ZONE				DIGIT			
	1 1 1 1				1 1 1 1			
Bit	8	4	2	1	8	4	2	1
Value Assigned To Bit	8	4	2	1	8	4	2	1
	8 + 4 + 2 + 1 = 15				8 + 4 + 2 + 1 = 15			
	Maximum Numerical Value For Zone Bits				Maximum Numerical Value For Digit Bits			

Figure 10-16. Maximum Values for Entire Character and for Zone and Digit Portions

Decimal Number	Hexadecimal Value
0	0
1	1
2	2
3	3
4	4
5	5
6	6
7	7
8	8
9	9
10	A
11	B
12	C
13	D
14	E
15	F

Figure 10-17. Hexadecimal Values of Numbers 0-15

An 8-bit combination with a zone value of 15 and a digit value of 12 is expressed as having a hexadecimal value of FC. Because the complete numbering series is composed of numbers 0 through 9 followed by letters A through F, a hexadecimal value for the zone and digit portion of an 8-bit combination can appear as a pair of numbers (61), a letter and a number (C4, 4F), or a pair of letters (DB).

Since zone and digit values are determined separately, a single combination of eight bits can have the same hexadecimal number for both the zone and digit portion. Thus, 11, 22, 33, AA, and other such values represent 8-bit combinations which have the same bits on in both their zone and digit portions.

Entirely different 8-bit combinations can have identical zone hexadecimal numbers *or* identical digit hexadecimal numbers, but not both. That is, the zone portion of one character can contain the same bits on and off as the zone portion of another character. In such a case, the identical zone bit combinations would give identical zone hexadecimal values. However, if they are different characters and the zone values are identical, the digit bits and, thus, the digit values, must differ. This is because no two characters can have the same 8-bit combination.

Figure 10-18 shows the hexadecimal values associated with the 64 printable characters the computer recognizes. The hexadecimal values are in sequence just as the regular numerical values are. Furthermore, the hexadecimal value associated with a character is equivalent to the numerical value associated with that character. However, there is no need for you to be able to translate back and forth between numerical values and hexadecimal values. If you must use a character's hexadecimal value in your programming, you can refer to the chart showing the appropriate value.

Character	Hexadecimal Value	Numerical Value
Blank	40	64
c	4A	74
.	4B	75
<	4C	76
(	4D	77
+	4E	78
	4F	79
&	50	80
!	5A	90
\$	5B	91
*	5C	92
)	5D	93
;	5E	94
	5F	95
-	60	96
/	61	97
,	6B	107
%	6C	108
-	6D	109
>	6E	110
?	6F	111
:	7A	122
#	7B	123
@	7C	124
'	7D	125
=	7E	126
"	7F	127
A	C1	193
B	C2	194
C	C3	195
D	C4	196
E	C5	197
F	C6	198
G	C7	199
H	C8	200
I	C9	201
} or -0	D0	208
J or -1	D1	209
K or -2	D2	210
L or -3	D3	211
M or -4	D4	212
N or -5	D5	213
O or -6	D6	214
P or -7	D7	215
Q or -8	D8	216
R or -9	D9	217
S	E2	226
T	E3	227
U	E4	228
V	E5	229
W	E6	230
X	E7	231
Y	E8	232
Z	E9	233
0	F0	240
1	F1	241
2	F2	242
3	F3	243
4	F4	244
5	F5	245
6	F6	246
7	F7	247
8	F8	248
9	F9	249

Figure 10-18. Hexadecimal Values Associated with Characters

**Saving Disk Storage Space**

As you have learned, each byte of storage, whether on disk or in the computer, can contain one character. That character can be a decimal number or an alphabetic or special character. The format of the characters is known as *unpacked decimal format*. Each byte of storage is divided into a 4-bit zone and a 4-bit digit part. Figure 10-19 shows the unpacked decimal format.

The zone part of the low-order (rightmost) byte indicates whether the decimal number is positive or negative. In unpacked decimal format, the zone part is included for each digit in a decimal number; however, only the zone over the low-order digit serves as the sign. The low-order digit is the only digit which makes use of the zone portion. Figure 10-20 shows the unpacked decimal format for decimal number 9,269.

**Packed Decimal Format**

In *packed decimal format* means that one byte of storage can contain two decimal numbers. A decimal number will occupy the zone portion which is unused in unpacked decimal format. This format allows you to put almost twice as much data into a byte as you can using the unpacked decimal format.

The low-order byte in packed decimal format is also divided into two 4-bit parts. Each byte, except the low-order byte, contains one decimal digit in each 4-bit part. The low-order byte contains a decimal digit in the leftmost 4-bit part (bits 0-3) and the sign of the decimal field in the rightmost 4-bit part (bits 4-7). Figure 10-21 shows packed decimal format.

The sign part of the low-order byte is used to indicate whether the numeric value represented in the digit parts is positive or negative. Compare how the decimal number 9,269 is represented in packed decimal format (Figure 10-22) with its unpacked representation (Figure 10-20).

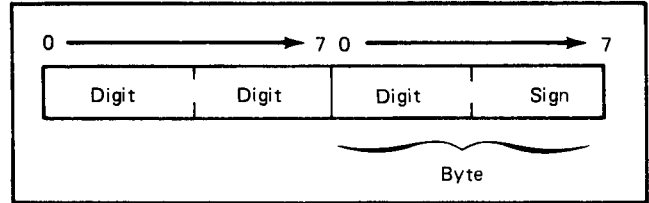

**Figure 10-21. Packed Decimal Format**

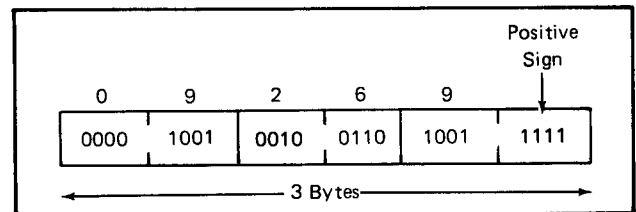

**Figure 10-22. Packed Format of Decimal Number 9,269**

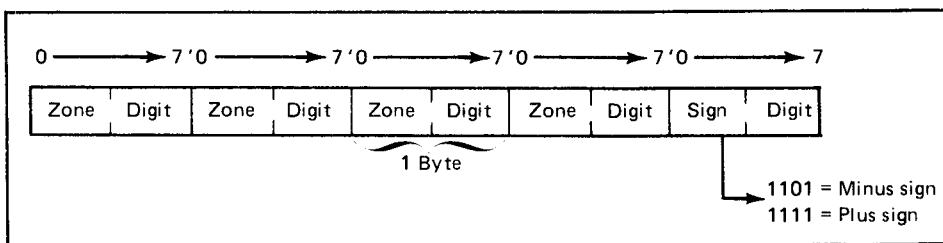

**Figure 10-19. Unpacked Decimal Format**

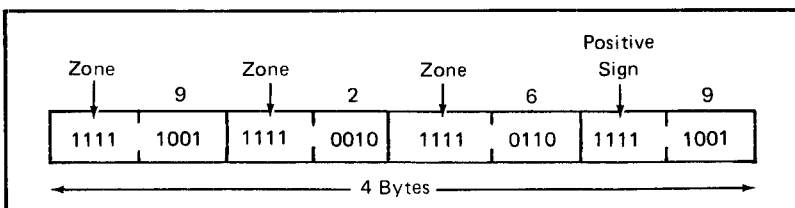

**Figure 10-20. Unpacked Format of Decimal Number 9,269**

You can specify packed input, output, table, or array fields:

- Packed input fields. Enter a *P* in column 43 of the Input sheet. This causes the data to be unpacked before it is stored.
- Packed output fields. Enter a *P* in column 44 of the Output-Format sheet. This causes the data to be packed before it is written out.
- Packed table or array fields. Enter a *P* in column 43 and/or 55 of the Extension sheet. The data will be unpacked before it is stored. Packed tables or arrays are allowed only at pre-execution time.

Since data must be represented in unpacked decimal format once it is inside the computer, you must give the RPG program an indication when input fields are in a different format.

Because data must be represented in unpacked decimal format before it can be processed, unpacked decimal fields may be stored on disk to eliminate converting the fields from packed to unpacked format during input. However, storing unpacked fields on disk requires more space than storing packed fields.

### Binary Format

You can save even more disk space than in packed decimal format by storing numeric data in *binary format*. In binary format, each numeric field on disk must be either two or four bytes long. Each two-byte binary field can contain a value equivalent to four decimal places; each four-byte binary field can contain a value equivalent to nine decimal places. In other words, a numeric value in binary format occupies approximately half as many bytes of disk storage as the equivalent value in unpacked decimal format.

Each two-byte binary field consists of a sign bit followed by a 15-bit numeric value. This value can be as large as 9,999. When a two-byte binary field from disk storage is read into the computer, the RPG II program converts it to a four-byte unpacked decimal field. Figure 10-23 shows a two-byte field in binary format.

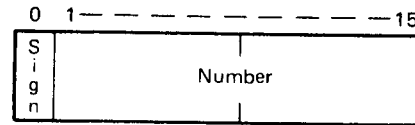

Figure 10-23. Two-Byte Field in Binary Format

Each four byte binary field consists of a sign bit followed by a 31-bit numeric value. This value can be as large as 999,999,999. When a four-byte binary field from disk storage is read into the computer, the RPG II program converts it to a nine-byte unpacked decimal field. A four-byte binary field is shown in Figure 10-24.

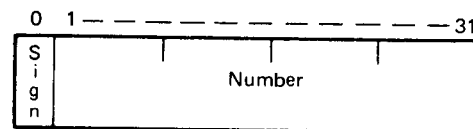

Figure 10-24. Four-Byte Field in Binary Format

In each case, the sign portion of the high-order byte (left-most) is used to indicate whether the numeric value is positive or negative. Notice that in the binary format the zone portion of the decimal number is not given. Compare how the decimal number 9,269 is represented in binary format (Figure 10-25) with its packed and unpacked representation (Figure 10-20 and 10-22).

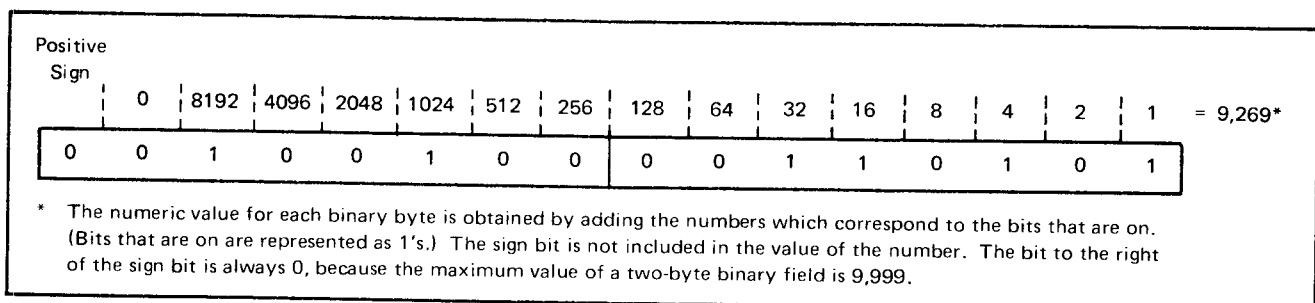

Figure 10-25. Binary Format of Decimal Number 9,269

Since data must be represented in unpacked decimal format when it is inside the computer, you must indicate to the RPG II program when fields are in another format. You can specify binary input, output, table, or array fields:

- Binary input fields. Enter a *B* in column 43 of the Input sheet. The data is then converted into decimal before it is stored.
- Binary output fields. Enter a *B* in column 44 of the Output-Format sheet. The data is then converted into binary before it is stored.
- Binary table or array fields. Enter a *B* in column 43 and/or 55 of the Extension sheet. The data will be converted to decimal before it is stored. Binary tables or arrays are allowed only at pre-execution time.

### COLLATING SEQUENCE OF CHARACTERS

To perform data processing applications efficiently, you usually organize your information in some order or sequence. Imagine trying to locate a person's phone number if the names in a telephone book were not in alphabetical order. Of course, before using this order or sequence, you must know what it is. Through the learning process, you know that alphabetical order means that *A* comes before *B*, *B* before *C*, and so on. Likewise, in numerical sequence, *1* is less than *2*, *2* less than *3*, and so on.

In most of your data processing applications, the computer must be able to recognize an order or sequence of data. For example, if you instruct the computer to sequence check a file according to an alphabetic department code on each record, it must be able to determine if the department *T* record should appear before the department *X* record, or vice versa. In another instruction, perhaps the computer is to compare two quantities, such as *3* and *8*, and turn on an indicator if the first quantity is less than the second quantity. The computer must determine if *3* is less than *8* or if *8* is less than *3*.

The previous two tasks would be easy for you to perform because, through memorization or habit, you know the natural order of the alphabetic characters *A* through *Z* and the numbers *0* through *9*. However, a computer has not memorized such orders. For the computer to perform these tasks, an order or sequence of characters must be established.

To further point out the need for a set order of characters, assume the computer must check to make sure records in a file are in proper order according to a department field. Some department codes are alphabetic, as department *A*; while some department codes are numbers, such as department *8*. Should the numeric department records appear before the alphabetic department records, or vice versa? It is likely that the answer would depend on who is asked. However, for efficient data processing, you certainly do not want records sorted one way one time and another way the next time. Thus, the computer must use *one* set order of characters.

Every character recognized by the computer must hold a certain position in this order in relation to the position of the rest of the characters. Such an order is referred to as a *collating sequence* of characters. By definition, *to collate* means to arrange or verify that data appears in proper order or sequence.

There can be any number of collating sequences. The sequence used depends on the particular order in which characters are to be recognized. In any case, the computer should use only one collating sequence at a time.

The standard collating sequence of 64 characters is shown in Figure 10-26. The blank, which is the first character, is considered as the lowest in the sequence while the number *9*, the last character, is the highest in the sequence. Note that all of the special characters, except the *{* (brace), are first in this sequence, followed by the alphabetic characters *A* through *Z* in their natural order, and then the numbers *0* through *9* in their natural order. The only character which you might not expect to be in its position is the *}* which comes between the letters *I* and *J*.

This collating sequence is the order used by the computer for the purpose of sorting cards, comparing numbers to determine which is greater or less, checking the sequence of records in a file, and matching records from two files to determine which record should be processed next. According to the collating sequence, the computer compares two characters to determine if one comes before or after the other, or is less than or greater than the other. Of course, you specify which characters (or fields of characters) are to be compared.

For sorting, sequence checking, and matching, you can specify an ascending or descending collating sequence. For example, if records are to be in ascending sequence, the characters being checked should be in the order shown in Figure 10-26. That is, a card with a blank should come before a card with the letter *K*. (The blank character is lower in sequence than the letter *K*.) Likewise, a card with the letter *K* should come before any records containing one of the numbers *0* through *9*. If you specify descending sequence, the computer compares to make sure they are in the opposite order, the characters higher in sequence coming first.

As mentioned, a computer cannot memorize the order of characters; it must use another method for *remembering* the collating sequence. To do this, it uses the values associated with characters to determine each character's relation to another character in the sequence.

In a previous discussion, a value is calculated for each bit combination in storage. The value can be thought of as a single numerical value for the entire 8-bit combination or as a 2-digit hexadecimal value, which is actually one hexadecimal number for each 4-bit combination (zone and digit). A hexadecimal value is another way of representing a numerical value.

Once a value is calculated, the computer uses it to determine which character is represented. Thus, the numerical value 193 (same as hexadecimal value C1) is associated with the character *A* while the numerical value 243 (hexadecimal value F3) is associated with the numeric character *3*. Perhaps you wonder why a particular value, such as 193 (C1) is related to the letter *A*, rather than a different value.

The values associated with the 64 characters were originally assigned such that the natural sequence of the values corresponds with the positions characters are to hold within the collating sequence. For example, the character *A* is associated with value 193 (hexadecimal C1), *B* with 194 (C2), *C* with 195 (C3), and so on. Just as *A* is lower than *B* and *B* is lower than *C* in the collating sequence, 193 (C1) is less than 194 (C2), and 194 (C2) is less than 195 (C3).

1	Blank
2	␣
3	.
4	<
5	(
6	+
7	
8	&
9	!
10	\$
11	*
12	)
13	;
14	␣
15	- (minus)
16	/
17	,
18	%
19	_ (underscore)
20	>
21	?
22	:
23	#
24	@
25	'
26	=
27	"
28	A
29	B
30	C
31	D
32	E
33	F
34	G
35	H
36	I
37	J
38	K
39	L
40	M
41	N
42	O
43	P
44	Q
45	R
46	S
47	T
48	U
49	V
50	W
51	X
52	Y
53	Z
54	0
55	1
56	2
57	3
58	4
59	5
60	6
61	7
62	8
63	9

Figure 10-26. Standard Collating Sequence

Figure 10-27 shows the 256 possible bit combinations, their numerical and hexadecimal values, and the characters associated with each. In this list of bit combinations, the numerical values are in order from 0 through 255 (hexadecimal values 00 through FF), and the associated characters are in the standard ascending collating sequence.

As you can readily see, the value associated with a character does not always *immediately* follow the value associated with the previous character in the sequence. For example, the character *S* follows the character *R* in the collating sequence of characters. However, the numerical value of *S*, 226 (hexadecimal E2), does not immediately follow the

Bit Combination	Character	Hexadecimal Value	Numerical Value
00000000		00	0
00000001		01	1
00000010		02	2
00000011		03	3
00000100		04	4
00000101		05	5
00000110		06	6
00000111		07	7
00001000		08	8
00001001		09	9
00001010		0A	10
00001011		0B	11
00001100		0C	12
00001101		0D	13
00001110		0E	14
00001111		0F	15
00010000		10	16
00010001		11	17
00010010		12	18
00010011		13	19
00010100		14	20
00010101		15	21
00010110		16	22
00010111		17	23
00011000		18	24
00011001		19	25
00011010		1A	26
00011011		1B	27
00011100		1C	28
00011101		1D	29
00011110		1E	30
00011111		1F	31
00100000		20	32
00100001		21	33
00100010		22	34
00100011		23	35
00100100		24	36
00100101		25	37
00100110		26	38
00100111		27	39
00101000		28	40
00101001		29	41
00101010		2A	42
00101011		2B	43
00101100		2C	44
00101101		2D	45
00101110		2E	46
00101111		2F	47
00110000		30	48
00110001		31	49
00110010		32	50

Bit Combination	Character	Hexadecimal Value	Numerical Value
00110011		33	51
00110100		34	52
00110101		35	53
00110110		36	54
00110111		37	55
00111000		38	56
00111001		39	57
00111010		3A	58
00111011		3B	59
00111100		3C	60
00111101		3D	61
00111110		3E	62
00111111		3F	63
01000000	Blank	40	64
01000001		41	65
01000010		42	66
01000011		43	67
01000100		44	68
01000101		45	69
01000110		46	70
01000111		47	71
01001000		48	72
01001001		49	73
01001010	¢	4A	74
01001011	.	4B	75
01001100	<	4C	76
01001101	(	4D	77
01001110	+	4E	78
01001111		4F	79
01010000	&	50	80
01010001		51	81
01010010		52	82
01010011		53	83
01010100		54	84
01010101		55	85
01010110		56	86
01010111		57	87
01011000		58	88
01011001		59	89
01011010	!	5A	90
01011011	\$	5B	91
01011100	*	5C	92
01011101	)	5D	93
01011110	;	5E	94
01011111		5F	95
01100000	-	60	96
01100001	/	61	97
01100010		62	98
01100011		63	99
01100100		64	100
01100101		65	101

Figure 10-27 (Part 1 of 3). Characters and Values Associated with the 256 Bit Combinations



numerical value of *R*, 217 (hexadecimal D9). The reason for the gap is because the bit combinations with the numerical values 218 through 225 are not associated with any of the 64 printable characters. Regardless, the computer determines that *R* is lower in sequence than (comes before) *S* because the value of *R* (217 or hexadecimal D9) is less than the value of *S* (226 or hexadecimal E2).

Bit Combination	Character	Hexadecimal Value	Numerical Value
01100110		66	102
01100111		67	103
01101000		68	104
01101001		69	105
01101010		6A	106
01101011	,	6B	107
01101100	%	6C	108
01101101	-	6D	109
01101110	>	6E	110
01101111	?	6F	111
01110000		70	112
01110001		71	113
01110010		72	114
01110011		73	115
01110100		74	116
01110101		75	117
01110110		76	118
01110111		77	119
01111000		78	120
01111001		79	121
01111010	:	7A	122
01111011	#	7B	123
01111100	@	7C	124
01111101	'	7D	125
01111110	=	7E	126
01111111	''	7F	127
10000000		80	128
10000001		81	129
10000010		82	130
10000011		83	131
10000100		84	132
10000101		85	133
10000110		86	134
10000111		87	135
10001000		88	136
10001001		89	137
10001010		8A	138
10001011		8B	139
10001100		8C	140
10001101		8D	141
10001110		8E	142
10001111		8F	143
10010000		90	144
10010001		91	145
10010010		92	146
10010011		93	147
10010100		94	148
10010101		95	149
10010110		96	150
10010111		97	151
10011000		98	152

Bit Combination	Character	Hexadecimal Value	Numerical Value
10011001		99	153
10011010		9A	154
10011011		9B	155
10011100		9C	156
10011101		9D	157
10011110		9E	158
10011111		9F	159
10100000		A0	160
10100001		A1	161
10100010		A2	162
10100011		A3	163
10100100		A4	164
10100101		A5	165
10100110		A6	166
10100111		A7	167
10101000		A8	168
10101001		A9	169
10101010		AA	170
10101011		AB	171
10101100		AC	172
10101101		AD	173
10101110		AE	174
10101111		AF	175
10110000		B0	176
10110001		B1	177
10110010		B2	178
10110011		B3	179
10110100		B4	180
10110101		B5	181
10110110		B6	182
10110111		B7	183
10111000		B8	184
10111001		B9	185
10111010		BA	186
10111011		BB	187
10111100		BC	188
10111101		BD	189
10111110		BE	190
10111111		BF	191
11000000		C0	192
11000001	A	C1	193
11000010	B	C2	194
11000011	C	C3	195
11000100	D	C4	196
11000101	E	C5	197
11000110	F	C6	198
11000111	G	C7	199
11001000	H	C8	200
11001001	I	C9	201
11001010		CA	202
11001011		CB	203

Figure 10-27 (Part 2 of 3). Characters and Values Associated with the 256 Bit Combinations

Bit Combination	Character	Hexadecimal Value	Numerical Value
11001100		CC	204
11001101		CD	205
11001110		CE	206
11001111		CF	207
11010000		D0	208
11010001	J	D1	209
11010010	K	D2	210
11010011	L	D3	211
11010100	M	D4	212
11010101	N	D5	213
11010110	O	D6	214
11010111	P	D7	215
11011000	Q	D8	216
11011001	R	D9	217
11011010		DA	218
11011011		DB	219
11011100		DC	220
11011101		DD	221
11011110		DE	222
11011111		DF	223
11100000		E0	224
11100001		E1	225
11100010	S	E2	226
11100011	T	E3	227
11100100	U	E4	228
11100101	V	E5	229
11100110	W	E6	230
11100111	X	E7	231
11101000	Y	E8	232
11101001	Z	E9	233
11101010		EA	234
11101011		EB	235
11101100		EC	236
11101101		ED	237
11101110		EE	238
11101111		EF	239
11110000	0	F0	240
11110001	1	F1	241
11110010	2	F2	242
11110011	3	F3	243
11110100	4	F4	244
11110101	5	F5	245
11110110	6	F6	246
11110111	7	F7	247
11111000	8	F8	248
11111001	9	F9	249
11111010		FA	250
11111011		FB	251
11111100		FC	252
11111101		FD	253
11111110		FE	254
11111111		FF	255

Figure 10-27 (Part 3 of 3). Characters and Values Associated with the 256 Bit Combinations

### Collating By Zone Or Digit

You learned from a previous discussion that the zone and digit portions of characters can be treated as separate and distinct groups of four bits, each with its own hexadecimal number.

Different characters may have identical zone bits or identical digit bits, but not both. Consequently, different characters may be associated with the same zone hexadecimal number of the same digit hexadecimal number but not both. As an example, the character *A* is associated with the value C1, *B* is associated with C2, and *K* is associated with D2. *A* has the same zone value (C) as *B*, while *K* has the same digit value (2) as *B*. However, *B* is the only character with both a zone value of C and a digit value of 2.

In most data processing tasks, the computer uses entire characters or the values of those characters to make comparisons, to determine which is greater or less, and so on. However, for certain purposes, such as sorting cards, you may wish to have the computer check only the zone or only the digit portion of characters. In such a case, the computer must use a collating sequence based on zone or digit values rather than the standard collating sequence based on the entire value.

If the computer uses a collating sequence based on the zone portions of characters, any differences in the digit bits are ignored. Only the value of the zone bits are considered. The reverse occurs if a collating sequence based on the digit portions of characters is to be used.

The fact that certain characters have the same zone or digit values can be used to group characters within a collating sequence. On the basis of zone values, the 64 printable characters are divided into eight groups (Figure 10-28). The zone bits (and values) are identical for all characters within a group. If collating is to be on the basis of digit values, the characters can be divided into 16 groups (Figure 10-29). In such a case, digit bits (and values) are identical for all characters within a particular group.

Using the standard collating sequence, the computer considers each character to hold a specific position in the sequence. Therefore, no two characters can be considered equal; one must come before another or be less than another character.

On the other hand, using a collating sequence based on zones or digits, one *group* of characters follows another *group* of characters. The characters within a group can occupy any position within that group. Thus, there is an order of groups but no particular order of characters within a group.

Character	Bit Combination		Collating Sequence of Zones
	Zone	Digit	
b (blank)	0100	0000	1
¢	0100	1010	
(period)	0100	1011	
<	0100	1100	
(	0100	1101	
+	0100	1110	
	0100	1111	
&	0101	0000	
!	0101	1010	
\$	0101	1011	
*	0101	1100	
)	0101	1101	
;	0101	1110	
⌋	0101	1111	
- (minus)	0110	0000	3
/	0110	0001	
,	0110	1011	
%	0110	1100	
_ (underscore)	0110	1101	
>	0110	1110	
?	0110	1111	
:	0111	1010	4
#	0111	1011	
@	0111	1100	
' (apostrophe)	0111	1101	
=	0111	1110	
"	0111	1111	

Character	Bit Combination		Collating Sequence of Zones
	Zone	Digit	
A	1100	0001	5
B	1100	0010	
C	1100	0011	
D	1100	0100	
E	1100	0101	
F	1100	0110	
G	1100	0111	
H	1100	1000	
I	1100	1001	
⌋	1101	0000	6
J or -1	1101	0001	
K or -2	1101	0010	
L or -3	1101	0011	
M or -4	1101	0100	
N or -5	1101	0101	
O or -6	1101	0110	
P or -7	1101	0111	
Q or -8	1101	1000	
R or -9	1101	1001	
S	1110	0010	7
T	1110	0011	
U	1110	0100	
V	1110	0101	
W	1110	0110	
X	1110	0111	
Y	1110	1000	
Z	1110	1001	
+0	1111	0000	
1	1111	0001	
2	1111	0010	
3	1111	0011	
4	1111	0100	
5	1111	0101	
6	1111	0110	
7	1111	0111	
8	1111	1000	
9	1111	1001	

Figure 10-28. Collating Sequence by Zone

Character	Bit Combination		Collating Sequence of Digits
	Zone	Digit	
6 (blank)	0100	0000	1
&	0101	0000	
- (minus)	0110	0000	
}	1101	0000	
+0	1111	0000	
/	0110	0001	2
A	1100	0001	
J or -1	1101	0001	
1	1111	0001	
B	1100	0010	3
K or -2	1101	0010	
S	1110	0010	
2	1111	0010	
C	1100	0011	4
L or -3	1101	0011	
T	1110	0011	
3	1111	0011	
D	1100	0100	5
M or -4	1101	0100	
U	1110	0100	
4	1111	0100	
E	1100	0101	6
N or -5	1101	0101	
V	1110	0101	
5	1111	0101	
F	1100	0110	7
O or -6	1101	0110	
W	1110	0110	
6	1111	0110	
G	1100	0111	8
P or -7	1101	0111	
X	1110	0111	
7	1111	0111	

Character	Bit Combination		Collating Sequence of Digits
	Zone	Digit	
H	1100	1000	9
Q or -8	1101	1000	
Y	1110	1000	
8	1111	1000	
I	1100	1001	10
R or -9	1101	1001	
Z	1110	1001	
9	1111	1001	11
¢	0100	1010	
!	0101	1010	
:	0111	1010	12
. (period)	0100	1011	
\$	0101	1011	
,	0110	1011	
#	0111	1011	13
<	0100	1100	
*	0101	1100	
%	0110	1100	
@	0111	1100	14
(	0100	1101	
)	0101	1101	
— (underscore)	0110	1101	
' (apostrophe)	0111	1101	15
+	0100	1110	
;	0101	1110	
>	0110	1110	
=	0111	1110	16
	0100	1111	
⌋	0101	1111	
?	0110	1111	
"	0111	1111	

Figure 10-29. Collating Sequence by Digit

Note that in the collating sequence by zone shown in Figure 10-28, any character in group 5 is considered lower in sequence than any character in group 6. If records are sorted in ascending order by zone, a record with the letter D (group 5) comes before a record with the letter N (group 6).

Now consider a case in which characters from the same zone group are to be compared. Assume one record contains the letter *D* (group 5) and the next record contains the letter *F* (group 5). Which should be sorted first according to a collating sequence based on zones? Since the computer ignores the digit bits of each character, they are considered equal because they both have the same zone value. Therefore, no one character must come earlier in the sequence than another character *from the same group*. The sequence of the characters is the same order in which the records are read. Thus, if the *D* card is read first by a sort program, the *D* record comes before the *F* record. On the other hand, if the *F* card is read first, the *F* record comes before the *D* record. In either case, the records are in proper sequence based on zones.

## ALTERING THE COLLATING SEQUENCE

A collating sequence is the order in which characters are arranged. As you know, all characters are associated with different numerical values in order that the computer may recognize them. The sequence of numerical values (ascending or descending sequence) determines the order in which characters associated with the values are recognized.

The association of a particular character with a numerical value is an arbitrary decision. Thus, the collating sequence itself is arbitrary. System/3 is programmed to expect the collating sequence discussed previously in the section *Collating Sequence of Characters*. This does not mean, however, that you must always use this sequence. You can change it and there may be times when you desire to do so.

For example, you may want alphabetic characters to follow the numbers instead of preceding them. Suppose that a company originally started with a few departments. The departments were assigned numbers from 01-99. Two columns were devoted to department numbers in various records. The company expanded and departments increased. Soon there were more than 99 departments. To avoid having to change the department field from two to three characters in all records, the manager decided to use the letters of the alphabet to represent department numbers: 99, A0, A1, etc. In this case, *A* must follow the number *9* in the sequence. Thus it is necessary to alter the collating sequence so that numbers come before alphabetic characters.

There can be other reasons than the one just explained for altering the collating sequence. Your language may demand that you have characters such as  $\acute{A}$ ,  $A'$ ,  $\acute{O}$ ,  $\acute{E}$ ,  $E'$  included in the alphabetic sequence (*A,  $\acute{A}$ , B*). Since the 64 graphics do not include these characters, other seldom used characters can be substituted for them and repositioned in the collating sequence. For example, a number-symbol (#) repositioned between the letters *A* and *B* can substitute for an  $\acute{A}$ ; an at-symbol (@) repositioned between *O* and *P* substitutes for an  $\acute{O}$ .

These are only a few reasons for altering the collating sequence. You may have others. Just remember that you can alter the collating sequence in any way that fits your needs.

## Specifying Changes in Collating Sequence

To change the collating sequence, you must associate characters with different numerical values. The following sections will explain how this is done.

International Business Machines Corporation

### RPG CONTROL CARD AND FILE DESCRIPTION SPECIFICATIONS

Punching Instruction    Graphic Punch

### Control Card Specifications

Date \_\_\_\_\_  
Program \_\_\_\_\_  
Programmer \_\_\_\_\_

Line	Core Size to	Core Size to	Keying Sequence		Sterling		Number		Keying Sequence
			Print	Print	Print	Print	Off	Off	

Refer to the specific System Reference Library manual for actual entries.

Form X21-9062  
Printed in U.S.A.

International Business Machines Corporation

### TRANSLATION TABLE AND ALTERNATE COLLATING SEQUENCE CODING SHEET

Code	System/3 Graphic	Entry	Replaced By/Takes Place Of
11001100		CC	
11001101		CD	
11001102		CE	
11001103		CF	
11001104		CG	
11001105	J	CH	
11001106		CI	
11001107		CJ	
11001108		CK	
11001109		CL	
11001110		CM	
11001111		CN	
11001112		CO	
11001113		CP	
11001114		CQ	
11001115		CR	
11001116		CS	
11001117		CT	
11001118		CU	
11001119		CV	
11001120		CW	
11001121		CX	
11001122		CY	
11001123		CZ	
11001124		EA	
11001125		EB	
11001126		EC	
11001127		ED	
11001128		EE	
11001129		EF	
11001130		EG	
11001131		EH	
11001132		EI	
11001133		EJ	
11001134		EK	
11001135		EL	
11001136		EM	
11001137		EN	
11001138		EO	
11001139		EP	
11001140		EQ	
11001141		ER	
11001142		ES	
11001143		ET	
11001144		EU	
11001145		EV	
11001146		EW	
11001147		EX	
11001148		EY	
11001149		EZ	
11001150		FA	
11001151		FB	
11001152		FC	
11001153		FD	
11001154		FE	
11001155		FF	

Code	System/3 Graphic	Entry	Replaced By/Takes Place Of
10011001		99	
10011002		9A	
10011003		9B	
10011004		9C	
10011005		9D	
10011006		9E	
10011007		9F	
10011008		A0	
10011009		A1	
10011010		A2	
10011011		A3	
10011012		A4	
10011013		A5	
10011014		A6	
10011015		A7	
10011016		A8	
10011017		A9	
10011018		AA	
10011019		AB	
10011020		AC	
10011021		AD	
10011022		AE	
10011023		AF	
10011024		AG	
10011025		AH	
10011026		AI	
10011027		AJ	
10011028		AK	
10011029		AL	
10011030		AM	
10011031		AN	
10011032		AO	
10011033		AP	
10011034		AQ	
10011035		AR	
10011036		AS	
10011037		AT	
10011038		AU	
10011039		AV	
10011040		AW	
10011041		AX	
10011042		AY	
10011043		AZ	
10011044		BA	
10011045		BB	
10011046		BC	
10011047		BD	
10011048		BE	
10011049		BF	
10011050		BG	
10011051		BH	
10011052		BI	
10011053		BJ	
10011054		BK	
10011055		BL	
10011056		BM	
10011057		BN	
10011058		BO	
10011059		BP	
10011060		BQ	
10011061		BR	
10011062		BS	
10011063		BT	
10011064		BU	
10011065		BV	
10011066		BW	
10011067		BX	
10011068		BY	
10011069		BZ	
10011070		CA	
10011071		CB	

Code	System/3 Graphic	Entry	Replaced By/Takes Place Of
01100110		66	
01100111		67	
01100112		68	
01100113		69	
01100114		6A	
01100115		6B	
01100116		6C	
01100117		6D	
01100118		6E	
01100119		6F	
01100120		6G	
01100121		6H	
01100122		6I	
01100123		6J	
01100124		6K	
01100125		6L	
01100126		6M	
01100127		6N	
01100128		6O	
01100129		6P	
01100130		6Q	
01100131		6R	
01100132		6S	
01100133		6T	
01100134		6U	
01100135		6V	
01100136		6W	
01100137		6X	
01100138		6Y	
01100139		6Z	
01100140		6A	
01100141		6B	
01100142		6C	
01100143		6D	
01100144		6E	
01100145		6F	
01100146		6G	
01100147		6H	
01100148		6I	
01100149		6J	
01100150		6K	
01100151		6L	
01100152		6M	
01100153		6N	
01100154		6O	
01100155		6P	
01100156		6Q	
01100157		6R	
01100158		6S	
01100159		6T	
01100160		6U	
01100161		6V	
01100162		6W	
01100163		6X	
01100164		6Y	
01100165		6Z	

Code	System/3 Graphic	Entry	Replaced By/Takes Place Of
00110011		33	
00110012		34	
00110013		35	
00110014		36	
00110015		37	
00110016		38	
00110017		39	
00110018		3A	
00110019		3B	
00110020		3C	
00110021		3D	
00110022		3E	
00110023		3F	
00110024		40	
00110025		41	
00110026		42	
00110027		43	
00110028		44	
00110029		45	
00110030		46	
00110031		47	
00110032		48	
00110033		49	
00110034		4A	
00110035		4B	
00110036		4C	
00110037		4D	
00110038		4E	
00110039		4F	
00110040		50	
00110041		51	
00110042		52	
00110043		53	
00110044		54	
00110045		55	
00110046		56	
00110047		57	
00110048		58	
00110049		59	
00110050		5A	
00110051		5B	
00110052		5C	
00110053		5D	
00110054		5E	
00110055		5F	
00110056		60	
00110057		61	
00110058		62	
00110059		63	
00110060		64	
00110061		65	

Code	System/3 Graphic	Entry	Replaced By/Takes Place Of
00000000		00	
00000001		01	
00000002		02	
00000003		03	
00000004		04	
00000005		05	
00000006		06	
00000007		07	
00000008		08	
00000009		09	
00000010		0A	
00000011		0B	
00000012		0C	
00000013		0D	
00000014		0E	
00000015		0F	
00000016		10	
00000017		11	
00000018		12	
00000019		13	
00000020		14	
00000021		15	
00000022		16	
00000023		17	
00000024		18	
00000025		19	
00000026		1A	
00000027		1B	
00000028		1C	
00000029		1D	
00000030		1E	
00000031		1F	
00000032		20	
00000033		21	
00000034		22	
00000035		23	
00000036		24	
00000037		25	
00000038		26	
00000039		27	
00000040		28	
00000041		29	
00000042		2A	
00000043		2B	
00000044		2C	
00000045		2D	
00000046		2E	
00000047		2F	
00000048		30	
00000049		31	
00000050		32	

Figure 10-30. Forms Needed for Alternate Collating Sequence Specifications

### Forms For Altering the Collating Sequence

Figure 10-30 illustrates two forms on which you must specify changes to the collating sequence. One form is the RPG II Control Card and File Description sheet; the other is the Translation Table and Alternate Collating Sequence Coding Sheet which is used for listing the actual changes in sequence. Both forms are used in conjunction with the RPG II Input, Output and Calculation sheets.

A letter *S* entered in column 26 of the RPG II control card notifies the program that additional information will be furnished to the program so that the collating sequence can be altered. All other columns contain the information that must normally be entered to process a job.

The Alternate Collating Sequence Coding Sheet lists 256 bit combinations along with their hexadecimal numerical values. As you learned from discussions of character structure, hexadecimal values are written in the form of two character values. One value represents the numerical value of the character's zone; the other represents the numerical value of the character's digit. The 64 printable graphics are listed beside the bit combinations and numerical values with which they are associated.

### Coding a Change in Sequence

Each change in the collating sequence is specified in the *Replaced By* column on the coding sheet. In this column, place the hexadecimal value of the graphic whose position in the normal sequence is to be changed. The *character* corresponding to the hexadecimal value entered in the *Replaced By* column replaces the character which is presently associated with the bit combination shown on the same line.

Figure 10-31 illustrates entries made to change the normal collating sequence. Hexadecimal values entered on the second and third lines of the sample coding sheet reverse the order in which the numbers 1 and 2 are recognized by the computer.

Numerical values entered on the second line of the sample specify that the number 2 (hexadecimal value F2) replaces the number 1. In other words, in the new sequence the number 2 is associated with the value F1 instead of the number 1. Hexadecimal values on the third line specify that the number 1 (hexadecimal value F1) replaces the number 2. These two specification lines cause 2 to come before 1 in the collating sequence (0, 2, 1, 3).

Code	System/3 Graphic	Entry	Replaced by
11110000	0	F0	
11110001	1	F1	F2
11110010	2	F2	F1
11110011	3	F3	
11110100	4	F4	
11110101	5	F5	

Character Associated with Bit Combination (points to System/3 Graphic column)

Numerical Value of the Replacement Character (points to Replaced by column)

8-Position Bit Combinations (points to Code column)

Numerical Value of Bit Combination (points to Entry column)

2 Replaces 1 (points to F2 in Replaced by of row 2)

1 Replaces 2 (points to F1 in Replaced by of row 3)

Figure 10-31. Explanation of Alternate Collating Sequence Sheet

### Effect of the Coded Change in Sequence

Any alternate collating sequence you specify is used temporarily. It is used only for the program which contains the alternate collating sequence specifications. Even more specifically, it is used in that program for operations which involve sequencing, such as checking sequence of records, comparing fields, or matching records.

You may think, according to specifications in Figure 10-31, that the character 2 read into the computer is *always* replaced by a 1. This is not true. The computer associates characters with the values you specify only before sequencing operations involving:

1. Compare operations on alphameric fields.
2. Matching or sequence checking match fields.

How does the computer keep track of the collating sequence to use? The computer keeps all your instructions for altering the sequence in storage. The area in storage which holds this information may be pictured as shown in Figure 10-32. These instructions combined with the pattern for normal sequence give the computer the correct collating sequence to use.

Numerical Value of Bit Combinations	Associated Characters	
	Normal Collating Sequence	Altered Collating Sequence
F0	0	0
F1	1	2
F2	2	1
F3	3	3
F4	4	4
F5	5	5
F6	6	6
F7	7	7

Figure 10-32. Storage Area Holding Alternate Collating Sequence Instruction

Consider the use of an altered sequence when determining which record to select for processing in a multifile program. The collating sequence has been changed so that 2 comes before 1.

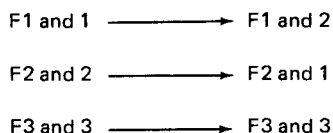

Figure 10-33 illustrates how the program uses the alternate sequence. Two cards are read into the read area. Just before the compare operation which is done to determine which match field has a lower value, the program checks to see if the characters used in the compare are affected by the alternate collating sequence instructions. They are. The character 1 normally associated with the value F1 is replaced by the character 2; the character 2 normally associated with the value F2 is replaced by the character 1.

When doing the compare, the program substitutes these values. For the match field having the character 2, the program uses the bit combination whose value is F1 instead of the bit combination for F2. Similarly for the match field containing a 1, the program uses the bit combination of F2 instead of the bit combination for F1. As a result of the compare, the primary card containing a 2 in the match field is chosen for processing. This card was chosen because F1 (now associated with character 2) is lower in sequence than F2 (now associated with the character 1).

After the compare, characters are again associated with values as assigned in the normal collating sequence.



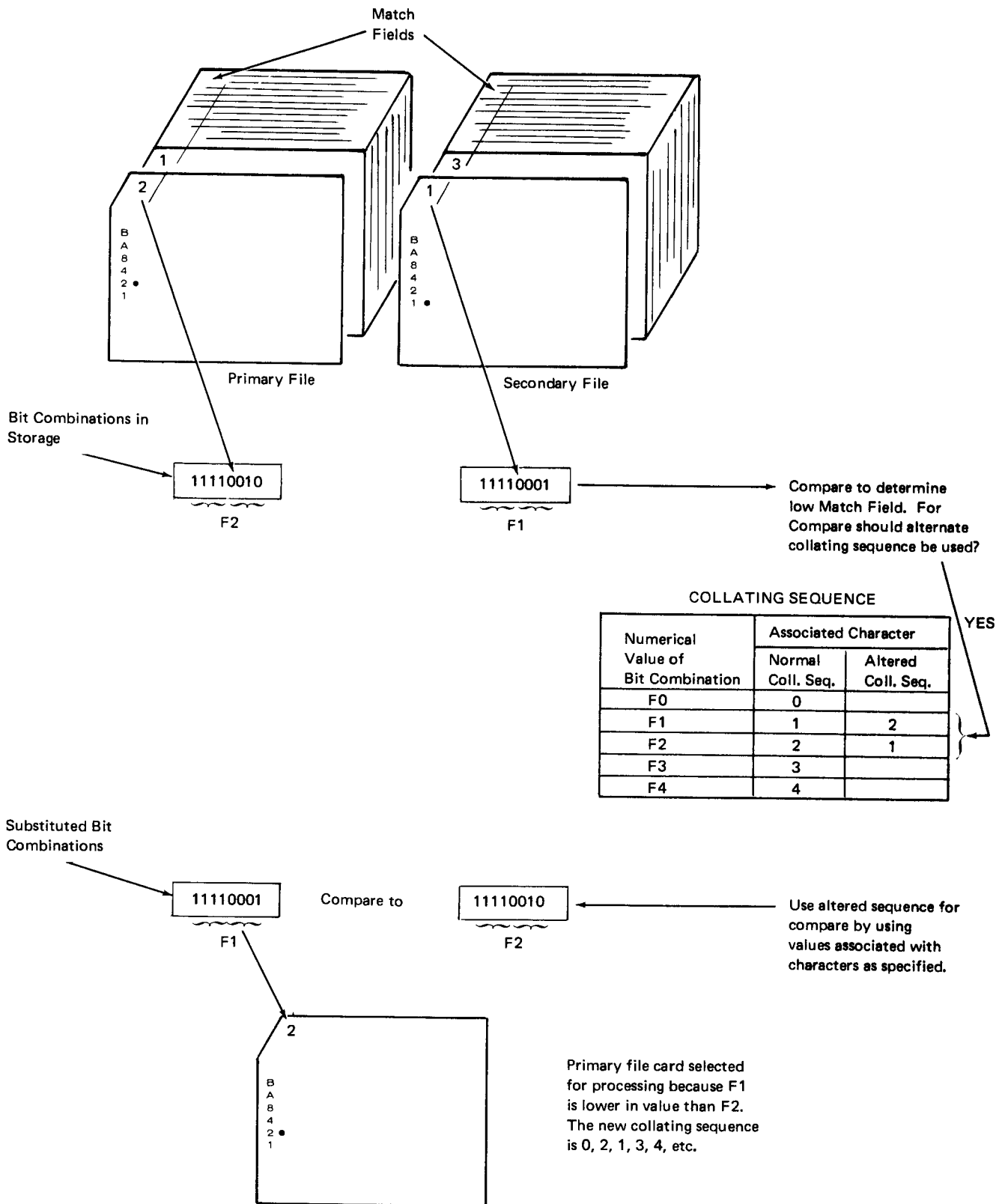

Figure 10-33. Using Alternate Collating Sequence (0, 1, 2, 3, 4, 9)

### Coding Characters to be Equal

Entries can be made to allow two characters to occupy the same position in the collating sequence; that is, they are associated with the same numeric value. When two characters occupy the same position in the sequence, the computer recognizes one character as being the same as the other.

Figure 10-34 illustrates the specifications which allow a blank or zero to occupy the same position in an altered sequence (assume the field is alphanumeric). The hexadecimal value associated with the character blank is replaced by the hexadecimal value (F0) which is already associated with the zero. Because the zero and blank are associated with the same numerical value, they are recognized as the same character. Figure 10-35 shows why a field containing a blank is equal to a field containing a zero when the altered sequence is used.

International Business Machines Corporation Form X21 9096  
Printed in U.S.A.

**TRANSLATION TABLE AND ALTERNATE COLLATING SEQUENCE CODING SHEET**

Code	System/3 Graphic	Entry	Replaced By/Takes Place Of	Code	System/3 Graphic	Entry	Replaced By/Takes Place Of	Code	System/3 Graphic	Entry	Replaced By/Takes Place Of	Code	System/3 Graphic	Entry	Replaced By/Takes Place Of
00110011		33		01100110		66		10011001		99		11001100		CC	
00110100		34		01100111		67		10011010		9A		11001101		CD	
00110101		35		01101000		68		10011011		9B		11001110		CE	
00110110		36		01101001		69		10011100		9C		11001111		CF	
00110111		37		01101010		6A		10011101		9D		11010000	J	00	
00111000		38		01101011		6B		10011110		9E		11010001	J	01	
00111001		39		01101100	%	6C		10011111		9F		11010010	K	02	
00111010		3A		01101101		6D		10100000		A0		11010011	L	03	
00111011		3B		01101110		6E		10100001		A1		11010100	M	04	
00111100		3C		01101111		6F		10100010		A2		11010101	N	05	
00111101		3D		01110000		70		10100011		A3		11010110	O	06	
00111110		3E		01110001		71		10100100		A4		11010111	P	07	
00111111		3F		01110010		72		10100101		A5		11011000	Q	08	
01000000	Blank	40	F0	01110011		73		10100110		A6		11011001	R	09	
01000001		41		01110100		74		10100111		A7		11011010		DA	
01000010		42		01110101		75		10101000		A8		11011011		DB	
01000011		43		01110110		76		10101001		A9		11011100		DC	
01000100		44		01110111		77		10101010		AA		11011101		DD	
01000101		45		01111000		78		10101011		AB		11011110		DE	
01000110		46		01111001				10101100		AC		11011111		DF	
01000111		47		01111010				10101101		AD		11100000		E0	
01001000		48		01111011				10101110		AE		11100001		F1	
01001001		49		01111100	#			10101111		AF		11100010	S	E2	
01001010	ç	4A		01111101	@	7C		10110000		B0		11100011	T	E3	
01001011	*	4B		01111110	=	7E		10110001		B1		11100100	U	E4	
01001100	<	4C		01111111	**	7F		10110010		B2		11100101	V	E5	
01001101	(	4D		10000000		80		10110011		B3		11100110	W	E6	
01001110	+	4E		10000001		81		10110100		B4		11100111	X	E7	
01001111		4F		10000010		82		10110101		B5		11101000	Y	E8	
01010000	&	50		10000011		83		10110110		B6		11101001	Z	E9	
01010001		51		10000100		84		10110111		B7		11101010		EA	
01010010		52		10000101		85		10111000		B8		11101011		EB	
01010011		53		10000110		86		10111001		B9		11101100		EC	
01010100		54		10000111		87		10111010		BA		11101101		ED	
01010101		55		10001000		88		10111011		BB		11101110		EE	
01010110		56		10001001		89		10111100		BC		11101111		EF	
01010111		57		10001010		8A		10111101		BD		11110000	0	F0	
01011000		58		10001011		8B		10111110		BE		11110001	1	F1	
01011001		59		10001100		8C		10111111		BF		11110010	2	F2	
01011010	!	5A		10001101		8D		11000000		C0		11110011	3	F3	
01011011	\$	5B		10001110		8E		11000001	A	C1		11110100	4	F4	
01011100	*	5C		10001111		8F		11000010	B	C2		11110101	5	F5	
01011101	)	5D		10010000		90		11000011	C	C3		11110110	6	F6	
01011110	^	5E		10010001		91		11000100	D	C4		11110111	7	F7	
01011111	~	5F		10010010		92		11000101	E	C5		11111000	8	F8	
01100000	~	60		10010011		93		11000110	F	C6		11111001	9	F9	
01100001	/	61		10010100		94		11000111	G	C7		11111010		FA	
01100010		62		10010101		95		11001000	H	C8		11111011		FB	
01100011		63		10010110		96		11001001	I	C9		11111100		FC	
01100100		64		10010111		97		11001010		CA		11111101		FD	
01100101		65		10011000		98		11001011		CB		11111110		FE	
												11111111		FF	

Zero Replaces Blank.

Figure 10-34. Specifying Blank Equal to Zero in New Collating Sequence

Compare Field A to Field B

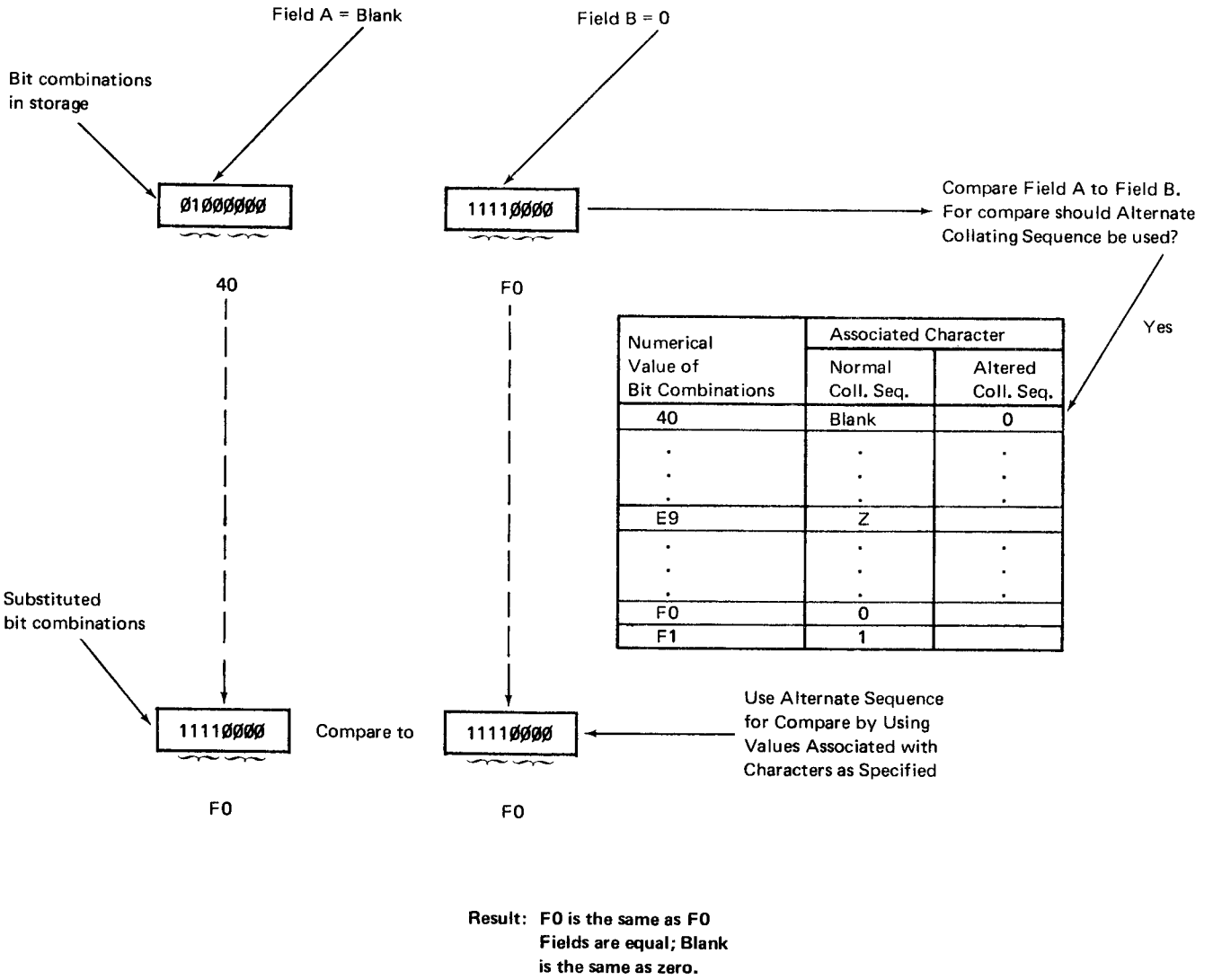

Figure 10-35. Using Alternate Collating Sequence (Blank Equals Zero)

*Example of the Coding of an Altered Sequence*

Figure 10-36 shows a part of the normal collating sequence, and one of several ways in which the sequence can be changed. Arrows depict changes required in the positions of characters to alter the sequence as shown at the right side of the figure.

In like manner, arrows in Figure 10-37 show entries on the coding sheet which must be specified to alter the sequence. Note that letters *B* through *I* are to be repositioned to allow the at-symbol (@) to appear between letters *A* and *B*. Identical results could be achieved by repositioning the value for the letter *A* to the line above, making it correspond to bit combination 1100000.

To produce the sequence shown in Figure 10-36 and 10-37, the appropriate hexadecimal values must be specified in the *Replaced By* column beside each graphic involved in the change. Figure 10-38 shows the actual coding required to alter the sequence.

Notice that each number which is to be collated before the alphabetic character is assigned a hexadecimal value which has no graphic associated with it. These values have no associated graphics that could have been assigned to the values previously associated with numbers. This is not necessary, however, because these values have no associated graphics. When two graphics are involved in the change, then both must be assigned different values except when they are to be considered equal.

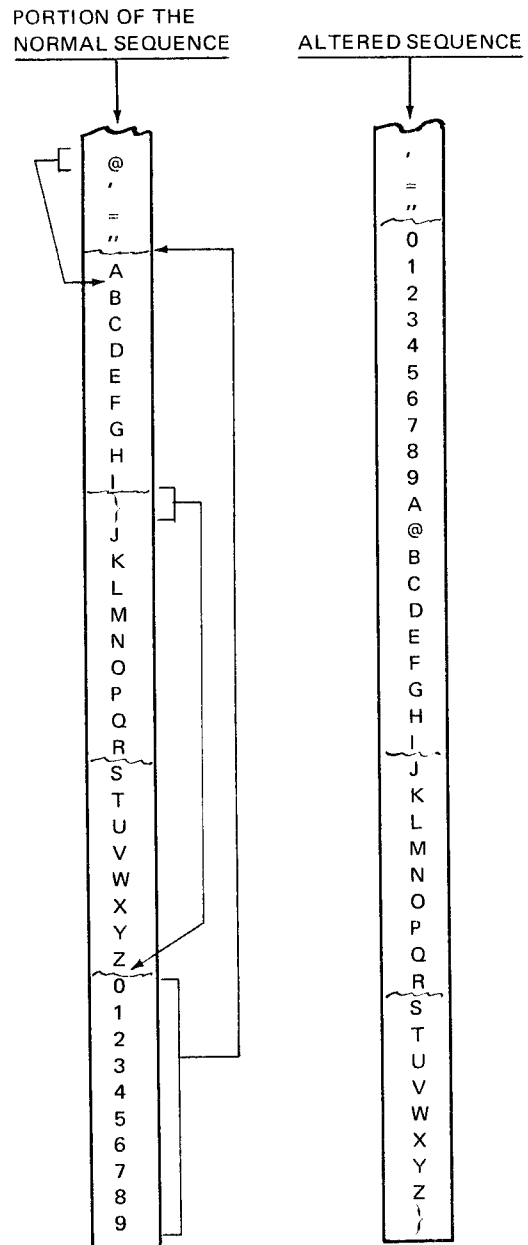

Figure 10-36. Normal Sequence Versus Altered Sequence

TRANSLATION TABLE AND ALTERNATE COLLATING SEQUENCE CODING SHEET

System/3 Graphic	Entry	Replaced By/Takes Place Of	Code	System/3 Graphic	Entry	Replaced By/Takes Place Of	Code	System/3 Graphic	Entry	Replaced By/Takes Place Of	Code	System/3 Graphic	Entry	Replaced By/Takes Place Of
	33		01100110		66		10011001		99		11001100		CC	
	34		01100111		67		10011010		9A		11001101		CD	
	35		01101000		68		10011011		9B		11001110		CE	
	36		01101001		69		10011100		9C		11001111		CF	
	37		01101010		6A		10011101		9D		11010000		00	
	38		01101011		6B		10011110		9E		11010001		D1	
	39		01101100	%	6C		10011111		9F		11010010		D2	
	3A		01101101		6D		10100000		A0		11010011		D3	
	3B		01101110		6E		10100001		A1		11010100		D4	
	3C		01101111		6F		10100010		A2		11010101		D5	
	3D		01110000		70		10100011		A3		11010110		D6	
	3E		01110001		71		10100100		A4		11010111		D7	
	3F		01110010		72		10100101		A5		11011000		D8	
Blank	40		01110011		73		10100110		A6		11011001		D9	
	41		01110100		74		10100111		A7		11011010		DA	
	42		01110101		75		10101000		A8		11011011		DB	
	43		01110110		76		10101001		A9		11011100		DC	
	44		01110111		77		10101010		AA		11011101		DD	
	45		01111000		78		10101011		AB		11011110		DE	
	46		01111001		79		10101100		AC		11011111		DF	
	47		01111010		7A		10101101		AD		11100000		E0	
	48		01111011		7B		10101110		AE		11100001		E1	
	49		01111100		7C		10101111		AF		11100010		E2	
¢	4A		01111101		7D		10110000		B0		11100011	S	E3	
	4B		01111110		7E		10110001		B1		11100100	T	E4	
<	4C		01111111		7F		10110010		B2		11100101	U	E5	
	4D		10000000		80		10110011		B3		11100110	V	E6	
+	4E		10000001		81		10110100		B4		11100111	W	E7	
	4F		10000010		82		10110101		B5		11101000	X	E8	
&	50		10000011		83		10110110		B6		11101001	Y	E9	
	51		10000100		84		10110111		B7		11101010	Z	EA	
	52		10000101		85		10111000		B8		11101011		EB	
	53		10000110		86		10111001		B9		11101100		EC	
	54		10000111		87		10111010		BA		11101101		ED	
	55		10001000		88		10111011		BB		11101110		EE	
	56		10001001		89		10111100		BC		11101111		EF	
	57		10001010		8A		10111101		BD		11110000	0	FO	
	58		10001011		8B		10111110		BE		11110001	1	F1	
	59		10001100		8C		10111111		BF		11110010	2	F2	
	5A		10001101		8D		11000000		C0		11110011	3	F3	
	5B		10001110		8E		11000001		C1	A	11110100	4	F4	
	5C		10001111		8F		11000010		C2	B	11110101	5	F5	
.	5D		10010000		90		11000011		C3	C	11110110	6	F6	
	5E		10010001		91		11000100		C4	D	11110111	7	F7	
	5F		10010010		92		11000101		C5	E	11111000	8	F8	
-	60		10010011		93		11000110		C6	F	11111001	9	F9	
/	61		10010100		94		11000111		C7	G	11111010		FA	
	62		10010101		95		11001000		C8	H	11111011		FB	
	63		10010110		96		11001001		C9		11111100		FC	
	64		10010111		97		11001010		CA		11111101		FD	
	65		10011000		98		11001011		CB		11111110		FE	
											11111111		FF	

Figure 10-37. Changes Necessary for Altered Sequence

TRANSLATION TABLE AND ALTERNATE COLLATING SEQUENCE CODING SHEET

System/3 Graphic	Entry	Replaced By/Takes Place Of	Code	System/3 Graphic	Entry	Replaced By/Takes Place Of	Code	System/3 Graphic	Entry	Replaced By/Takes Place Of	Code	System/3 Graphic	Entry	Replaced By/Takes Place Of
	33		01100110		66		10011001		99		11001100		CC	
	34		01100111		67		10011010		9A		11001101		CD	
	35		01101000		68		10011011		9B		11001110		CE	
	36		01101001		69		10011100		9C		11001111		CF	
	37		01101010		6A		10011101		9D		11010000		D0	
	38		01101011		6B		10011110		9E		11010001		D1	
	39		01101100	%	6C		10011111		9F		11010010	K	D2	
	3A		01101101	-	6D		10100000		A0		11010011	L	D3	
	3B		01101110	>	6E		10100001		A1		11010100	M	D4	
	3C		01101111	?	6F		10100010		A2		11010101	N	D5	
	3D		01110000		70		10100011		A3		11010110	O	D6	
	3E		01110001		71		10100100		A4		11010111	P	D7	
	3F		01110010		72		10100101		A5		11011000	Q	D8	
Blank	40		01110011		73		10100110		A6		11011001	R	D9	
	41		01110100		74		10100111		A7		11011010		DA	
	42		01110101		75		10101000		A8		11011011		DB	
	43		01110110		76		10101001		A9		11011100		DC	
	44		01110111		77		10101010		AA		11011101		DD	
	45		01111000		78		10101011		AB		11011110		DE	
	46		01111001		79		10101100		AC		11011111		DF	
	47		01111010		7A		10101101		AD		11100000		E0	
	48		01111011	@	7B		10101110		AE		11100001		E1	
	49		01111100		7C		10101111		AF		11100010	S	E2	
ç	4A		01111101		7D		10110000		B0		11100011	T	E3	
.	4B		01111110		7E		10110001		B1		11100100	U	E4	
<	4C		01111111		7F		10110010		B2		11100101	V	E5	
(	4D		10000000		80		10110011		B3		11100110	W	E6	
+	4E		10000001		81		10110100		B4		11100111	X	E7	
	4F		10000010		82		10110101		B5		11101000	Y	E8	
&	50		10000011		83		10110110		B6		11101001	Z	E9	
	51		10000100		84		10110111		B7		11101010		EA	DO
	52		10000101		85		10111000		B8		11101011		EB	
	53		10000110		86		10111001		B9		11101100		EC	
	54		10000111		87		10111010		BA		11101101		ED	
	55		10001000		88		10111011		BB		11101110		EE	
	56		10001001		89		10111100		BC		11101111		EF	
	57		10001010		8A		10111101		BD		11110000	0	F0	
	58		10001011		8B		10111110		BE		11110001	1	F1	
	59		10001100		8C		10111111		BF		11110010	2	F2	
!	5A		10001101		8D		11000000		C0		11110011	3	F3	
¢	5B		10001110		8E		11000001	A	C1		11110100	4	F4	
£	5C		10001111		8F		11000010	B	C2		11110101	5	F5	
¤	5D		10010000		90		11000011	C	C3		11110110	6	F6	
¥	5E		10010001		91		11000100	D	C4		11110111	7	F7	
¦	5F		10010010		92		11000101	E	C5		11111000	8	F8	
§	60		10010011		93		11000110	F	C6		11111001	9	F9	
¨	61		10010100		94		11000111	G	C7		11111010		FA	
©	62		10010101		95		11001000	H	C8		11111011		FB	
ª	63		10010110		96		11001001	I	C9		11111100		FC	
«	64		10010111		97		11001010	J	CA		11111101		FD	
¬	65		10011000		98		11001011		CB		11111110		FE	
											11111111		FF	

Figure 10-38. Coding for Altered Sequence

### Recording Specifications for the Altered Sequence

After you have coded all specifications for the alternate collating sequence, you can record them so that they can be used by the computer. Records describing the alternate sequence are to be formatted as follows:

Positions	Entries
1-6	ALTSEQ (This entry allows the computer to recognize that this record is describing an alternate sequence.)
7-8	Blank
9-96	The hexadecimal values involved in changing the sequence.

In positions 9-96, there are 22 groups of 4 positions. Each group (9-12, 13-16, etc.) must contain two hexadecimal values involved in changing the sequence. The first two positions of a group are for the hexadecimal value taken from the *Entry* column of the Alternate Collating Sequence

Coding Sheet. The last two positions in a group are for the hexadecimal value taken from the *Replaced By* column of the coding sheet (Figure 10-39).

More than one record may be used to specify changes in collating sequence. However, each additional record must be formatted in the same way as the first.

The first blank appearing in positions 9-96 is recognized by the compiler as the end of the record. Consequently, blanks must not appear between pairs of hexadecimal values.

A record containing \*\*b (two asterisks and a blank) in positions 1 through 3 must precede the sequence records.

All records (except the RPG II control card) used for altering the collating sequence must follow RPG II specifications (or file translation specifications, when used) and must precede any tables being entered.

Note:  
Although a card is shown in this figure, remember, alternate collating sequence data can also be entered by means of keyboard or disk.

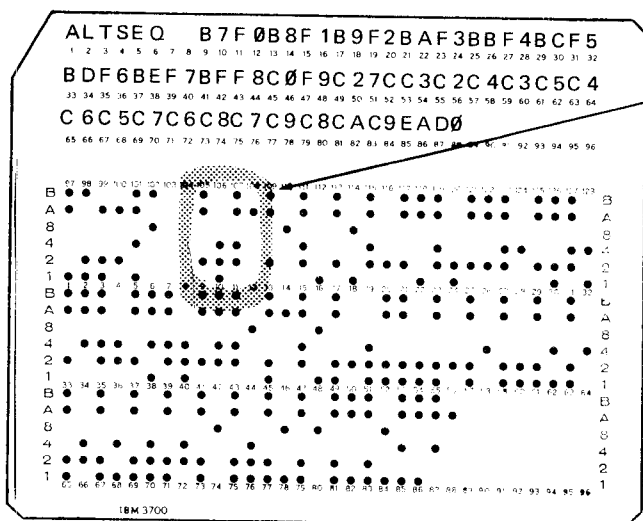

Form X21-9096  
Printed in U.S.A.

System/3 Graphic	Entry	Replaced By/Takes Place Of	Code	System/3 Graphic	Entry	Replaced By/Takes Place Of
	99		11001100		CC	
	9A		11001101		CD	
	9B		11001110		CE	
	9C		11001111		CF	
	9D		11010000		DD	
	B7		11101010		EA	DD
	B8		11101011		EB	
	B9		11101100		EC	
	BA		11101101		ED	
	BB		11101110		EE	
	BC		11101111		EF	
	BD		11110000	0	F0	
	BE		11110001	1	F1	
	BF		11110010	2	F2	
	C0		11110011	3	F3	
	C1		11110100	4	F4	
	C2		11110101	5	F5	
	C3		11110110	6	F6	
	C4		11110111	7	F7	
	C5		11111000	8	F8	
	C6		11111001	9	F9	
	C7		11111010		FA	
	C8		11111011		FB	
	C9		11111100		FC	
	CA		11111101		FD	
	CB		11111110		FE	
			11111111		FF	

Figure 10-39. Punching Alternate Collating Sequence Cards

## ALTERING THE STRUCTURE OF CHARACTERS

You learned in the discussion of character structure that each System/3 graphic is represented in the machine by a unique setting of eight bits; four zone bits and four digit bits. If any change is made to either the zone or digit bits, the entire character is changed. For example, if the *A* bit of the letter *M* is changed from on to off, the letter *M* becomes the letter *D* (Figure 10-40).

You can, of course, change a character before it is read into the computer by punching different zone punches on the card. But you can also change a character after it has been read. This is done by changing the zones of characters through the use of move zone operation codes.

Why would you ever want to change the zone of a character after it has been read? One common reason for changing zones is to deliberately change the sign of a field from positive to negative, or vice versa.

This is necessary when a numeric field read in from a special file has its sign in the high-order (leftmost) position of the field. Numeric fields are required to have the sign in the low-order (rightmost) position of the field. Thus, a numeric input field having its sign in the high-order position must have its sign moved to the low-order position. The move zone operations allow you to do this.

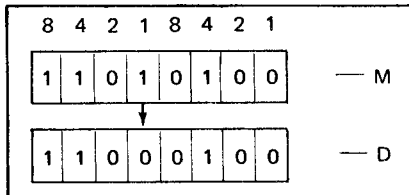

Figure 10-40. Changing Zones Changes Characters

### How Move Zone Operations Work

Move zone operations involve only the zone portion of characters. The computer does not actually move the zone of one character to the zone portion of another. Rather, it changes a character by making its zone identical to the zone of the character which you indicate should serve as the model. The character serving as a model is not changed by the operation.

Thus, in order to use the move zone operations you must have:

1. A character which needs to be changed.
2. A character that has the zone you want the changed character to have.

For example, if you want the low-order (rightmost) position of the field AMOUNT to be changed from a positive 5 to a negative 5 you must have a character to serve as a model whose zone portion is the same as the zone of a negative five.

### Coding a Move Zone Operation

Figure 10-41 illustrates the way in which a move zone operation is coded. The name of the field containing the character to be changed must be entered in the Result Field. Either a constant of the name of the field which contains the model character must be entered in Factor 2. The move zone operation code is specified in the Operation columns (28-32). Any conditioning indicators you wish to use can be specified, but resulting indicators cannot be used.

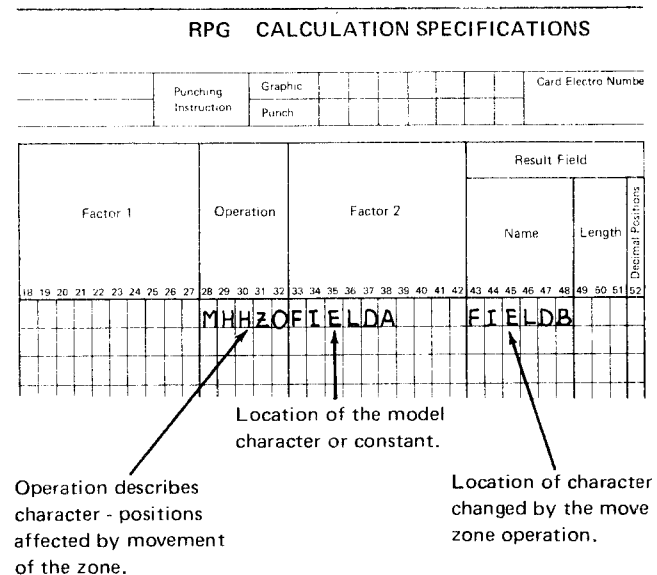

Figure 10-41. Coding for a Move Zone Instruction



### Differences in the Move Zone Operations

There are four different move zone operation codes available. Each code involves the zones of characters located in different positions; namely:

1. High-order positions in both Factor 2 and the Result Field.
2. High-order position in Factor 2 and low-order in the Result Field.
3. Low-order positions in both Factor 2 and the Result Field.

4. Low-order position in Factor 2 and high-order in the Result Field.

Since only the zones of high and low-order characters in a field or constant are involved in the move zone operations, only the high or low-order positions of a field can be changed.

Figure 10-42 illustrates the ways in which the four operation codes affect the zone of a character in the Result Field.

Factor 1	Operation	Factor 2	Result Field	
			Name	Length
18 19 20 21 22 23 24 25 26 27	28 29 30 31 32	33 34 35 36 37 38 39 40 41 42	43 44 45 46 47 48	49 50 51
	MHHZ	ALPHA1	ALPHA2	

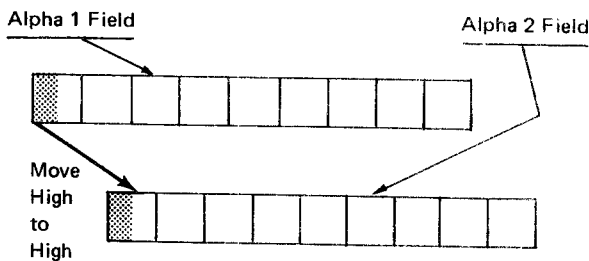

Factor 1	Operation	Factor 2	Result Field	
			Name	Length
18 19 20 21 22 23 24 25 26 27	28 29 30 31 32	33 34 35 36 37 38 39 40 41 42	43 44 45 46 47 48	49 50 51
	MHLZ	ALPHA1	NUMER1	

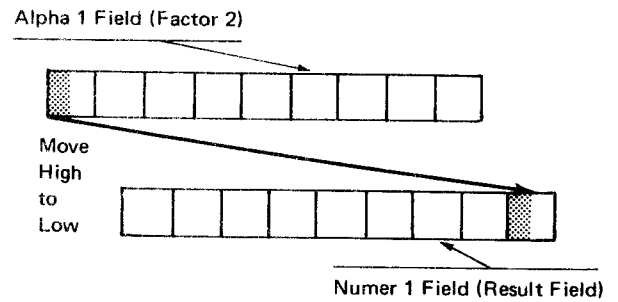

Factor 1	Operation	Factor 2	Result Field	
			Name	Length
18 19 20 21 22 23 24 25 26 27	28 29 30 31 32	33 34 35 36 37 38 39 40 41 42	43 44 45 46 47 48	49 50 51
	MLHZ	NUMER1	ALPHA1	

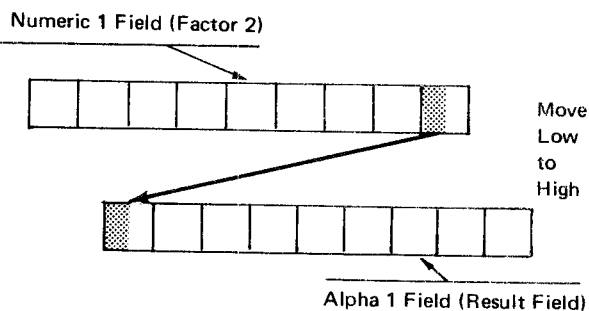

Factor 1	Operation	Factor 2	Result Field	
			Name	Length
18 19 20 21 22 23 24 25 26 27	28 29 30 31 32	33 34 35 36 37 38 39 40 41 42	43 44 45 46 47 48	49 50 51
	MLLZ	NUMER1	NUMER2	

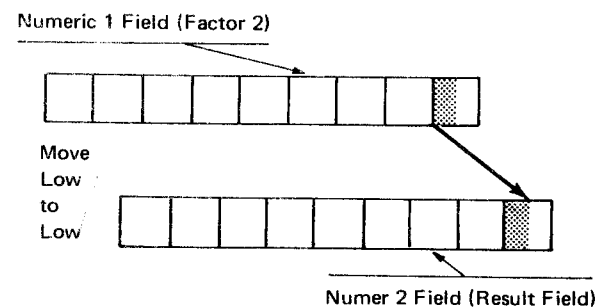

Figure 10-42. Move Zone Operations

### *Move From High-Order Zone to High-Order Zone (MHHZO)*

This operation code moves the zone of the high-order (left-most) alphameric character in the constant or field entered in Factor 2 to the high-order alphameric character in the Result Field.

### *Move From Low-Order Zone to High-Order Zone (MLHZO)*

This operation code moves the zone of the low-order (right-most) character in the field or constant entered in Factor 2 to the high-order alphameric character in the Result Field. The Result Field must be alphameric; Factor 2 can be either numeric or alphameric.

### *Move From High-Order Zone to Low-Order Zone (MHLZO)*

This operation code moves the zone of the high-order alphameric character in the constant or field entered in Factor 2 to the low-order rightmost character in the Result Field. Because of its high-order zone, Factor 2 must be an alphameric field. The Result Field can be either alphameric or numeric.

### *Move From Low-Order Zone to Low-Order Zone (MLLZO)*

This operation code moves the zone of the low-order character in the field or constant entered in Factor 2 field to the low-order character in the Result Field. Both Factor 2 and the Result Field can be either numeric or alphameric.

## **Field Format and Move Zone Operations**

As you read the description of each move zone operation, you probably noticed that special attention was given to the types of fields which can be used with each operation. Keep in mind that you cannot move from or to the high-order positions of a numeric field because the computer does not use the high-order zone of fields defined as numeric.

Which of the following move zone operations can be done if the two fields involved have formats as given below?

1. Alphameric to Alphameric: MHLZO
2. Alphameric to Numeric: MHHZO
3. Numeric to Alphameric: MLHZO
4. Numeric to Alphameric: MHHZO
5. Numeric to Numeric: MLHZO
6. Numeric to Numeric: MLLZO

Items 1, 3, and 6 can be done. Items 2, 4, and 5 cannot be done. Item 2 suggests that the zone of the high-order position in the numeric field be changed. The computer does not use high-order zone of numeric fields. Item 4 suggests that the zone of the high-order character is to serve as a model. It cannot because the computer does not work with the zones of high-order characters in a numeric field. Item 5 cannot be done because again it involves high-order positions of numeric fields.

## **Example of a Move Zone Operation**

Now that you know how the various move zone operation codes work, let's see how they can be used to change the sign of the field, VALUE, from the high-order to the low-order position.

Naturally any field that has zones other than in the low-order position must be defined as alphameric if those zones are to be used by the computer. But if the field is to be involved in an arithmetic operation, it must be numeric.

To allow for both possibilities, you could define the field twice; once as alphameric and once as numeric. (Two unique field names are needed.) Another possibility is to define the field once as alphameric and then change it into a numeric field by moving it into a numeric field. This is what is done in the example (Figure 10-43).

Before doing any arithmetic operation, you must get the sign in the low-order position of a *numeric* field. You may want to first determine what the sign is by means of a TESTZ operation. Remember that TESTZ turns on the minus indicator when it finds the characters -, {, or J through R in the high-order position of the tested field. The specification in Figure 10-43, insert B, line 02, causes indicator 20 to turn on if the sign of the field is minus. If indicator 20 is on, the zone of VALUE, which is the minus sign to the computer, is moved to the low-order position of the AMOUNT field. If the field tested is plus, no zone is moved because a numeric field having no minus sign is automatically assumed to be positive.

Notice that the MHLZO (Move High to Low Zone) operation code was used to change the zone of the low-order position of the AMOUNT field by giving it the same zone as the high-order position of VALUE.

*Note:* This example can also be accomplished without using a TESTZ operation. First, move the zone of the high-order position of the field VALUE to the low-order position. This puts the sign in the low-order position. The alphameric VALUE field can then be moved to the numeric AMOUNT field and the arithmetic operation can be performed.

## Choosing the Model Character for Factor 2

Before specifying a move zone operation, you must have a character designated in Factor 2 whose zone will give the desired zone in the Result Field.

Usually you will use move zone operations to change the signs of fields. Using any numbers in Factor 2 will produce a positive character in the Result Field. Using any one of the character { or J-R in Factor 2 will give you a negative character. The - (minus, X'60') character does not work to make a character negative using the move zone operation. Remember that negative numbers are punched with a B punch (minus sign) over the number. The punch combinations of negative numbers have the same numeric value in the computer as J-R. Thus, when you specify that the zone of a character should be made like the zone of J-R, you will get a minus character. See *Character Structure* for more information.

Use Figure 10-28 as a guide for selecting the zone which will produce the desired change.

IBM Form GX21 9094 U-M 0507  
Printed in U.S.A.

Form GX21 9093  
Printed in U.S.A.

**RPB INPUT SPECIFICATIONS**

Program: \_\_\_\_\_ Date: \_\_\_\_\_ Punching Instruction: \_\_\_\_\_ Graphic: \_\_\_\_\_ Card Electro Number: \_\_\_\_\_

Page 1 of 2 Program Identification 75 76 77 78 79 80

Line	Form Type	Filename	Sequence	Number (L, N)	Group (R)	Record Identifying Indicator	Record Identification Codes			Field Location	Field Name	Field Indicators				
							1	2	3			Plus	Minus	Zero or Blank		
1	I	CARDSIN	NS	01	01	01										
2	I									10	ACCTNO					
3	I									18	VALUE					

**RPB CALCULATION SPECIFICATIONS**

Program: \_\_\_\_\_ Date: \_\_\_\_\_ Punching Instruction: \_\_\_\_\_ Graphic: \_\_\_\_\_ Card Electro Number: \_\_\_\_\_

Page 1 of 2 Program Identification 75 76 77 78 79 80

Line	Form Type	Control Level (LD, L)	Indicators			Factor 1	Operation	Factor 2	Result Field		Resulting Indicators	Comments
			And	And	Not				Name	Length		
01	C					MOVE VALUE	AMOUNT	82		Arithmetic		
02	C					TESTZ	VALUE	20		Plus		
03	C					MHLZ VALUE	AMOUNT			Minus		

Figure 10-43. Using Move Zone Operations to Change the Sign of a Field



## TRANSLATING CHARACTERS

In the previous discussion, you learned that the program can alter the structure of characters by moving zones. But, through the file translation function of the RPG II language, it can do even more. It can translate one character into another.

The translating function is known as file translation because characters can be translated either when they are read in or before they are recorded in the output file. The program acts like an interpreter. Just as a human interpreter translates languages (a word in German for a word in English), the computer translates characters by replacing one character with another.

### Need for File Translation

Think of the use for file translation when translating codes. Codes are often used as a security measure to prevent access to classified information. Information is recorded on cards in coded form. In order to process the information, it must be decoded. A coded character must be replaced by the corresponding decoded character.

For example, a firm which keeps all information classified uses the characters in the word FITZGERALD as a code for the numbers 0 through 9. *F* is the code for zero, *I* for one, etc. When recorded on a card, the number 1432 appears as IGZT. If a field containing IGZT is read into the computer and used in arithmetic operations, results received are wrong. IGZT must first be decoded, or translated into 1432.

### Specifying File Translation

Specifications for file translation are identical to those used to alter the collating sequence.

### Forms Used for a File Translation

Figure 10-44 shows the forms on which you must specify the way in which files are to be translated. One form consists of the RPG II Control Card and File Description sheet; the other consists of the Translation Table and Alternate Collating Sequence Coding Sheet for listing the characters to be translated. Both forms are used in conjunction with the RPG II Input, Output, and Calculation sheets.

Only column 43 in the RPG II control card relates to the change in sequence. A letter *F* entered in column 43 notifies the computer that additional information furnished for translating files. All other columns contain the information that must normally be entered for a program.

The Translation Table and Alternate Collating Sequence Coding Sheet lists 256 bit combinations along with their hexadecimal numerical values. You learned from discussions of character structure that the left-hand number in the hexadecimal value represents the numerical value of the character's zone and the right-hand number represents the numerical value of the character's digit. The 64 printable characters are listed beside the bit combination and hexadecimal values with which they are associated.

### Coding the Translation

Each character that will be affected during the translation of a specified file must be identified on the coding sheet. In the column entitled *Replaced By*, enter the hexadecimal value of the character which is to replace the character presently associated with the bit combination shown. This means that the character associated with the value found in the *Entry* column will be translated into the character associated with the value entered in the *Replaced By* column.

Figure 10-45 illustrates the entry made on the coding sheet to translate a character. If an input file is to be translated, this entry means that the letter *F* will be translated as the number 0 (F0 is the hexadecimal value associated with 0).

Code	System/3 Graphic	Entry	Replaced By
11000100	D	C4	
11000101	E	C5	
11000110	F	C6	F0
11000111	G	C7	
11001000	H	C8	
11001001	I	C9	

Character Associated with Bit Combination (points to System/3 Graphic column)

Numerical Value of Replacement Character (points to Replaced By column)

Numerical Value of Bit Combination (points to Code column)

F is translated to 0 (points to the F0 in the Replaced By column)

Figure 10-45. Explanation of File Translation Coding Sheet

If the output file is to be translated, this entry means that the number *O* will be translated back into an *F* before being written out. You can think of the character associated with the value in the *Entry* column as being the character read in or printed out. On the other hand, the character associated with the values in the *Replaced By* column is the character represented in the machine (Figure 10-46).

#### *Differences Between File Translation and Alternate Collating Sequence*

Because of the similarity of entries used in coding an alternate collating sequence and a file translation, these functions may seem identical. They are not, however. The difference occurs in the way the program works with the characters involved.

When alternate collating sequence is used, the characters are altered only temporarily for sequencing operations. The original bit combination of the character, obtained from the punch combination for that character, is not changed. Temporary substitution of another bit combination is done instead.

For file translation, bit combinations are actually changed. As a result, one character is changed (translated) into another. This translation occurs before your program instructions are executed.

#### *What Files Should Be Translated?*

Any input files which contain information recorded in coded form should be translated if correct results are to be obtained. All characters which you specify to be translated are translated whenever they are encountered. This means if you specify an *F* to be translated to *O*, all *F*'s read in will be translated. When there are several other fields on the cards in addition to the one containing coded information, remember all characters specified to be translated are translated regardless of fields.

When printing or punching information out, you may or may not find it necessary to specify file translation for the output files. If you have translated (decoded) your input file, you should translate information back into coded form before it is written or punched out. If all *F*'s are translated as *O*'s when read in, then all *O*'s should be translated to *F*'s before they are put out. Keep in mind that only characters which you specify are involved in the retranslation.

TRANSLATION TABLE AND ALTERNATE COLLATING SEQUENCE CODING SHEET

System/3 Graphic	Entry	Replaced By/Takes Place Of	Code	System/3 Graphic	Entry	Replaced By/Takes Place Of	Code	System/3 Graphic	Entry	Replaced By/Takes Place Of	Code	System/3 Graphic	Entry	Replaced By/Takes Place Of
1	33		01100110		66		10011001		99		11001100			CC
	34		01100111		67		10011010		9A		11001101			CD
	35		01101000		68		10011011		9B		11001110			CE
			01101001		69		10011100		9C		11001111			CF
			01101010		6A		10011101		9D		11010000	J		D0
					6B		10011110		9E		11010001	J		D1
					6C		10100000		9F		11010010	K		D2
					6D		10100001		A0		11010011	L		D3
							10100010		A1		11010100	M		D4
							10100011		A2		11010101	N		D5
							10100100		A3		11010110	O		D6
							10100101		A4		11010111	P		D7
							10100110		A5		11011000	Q		D8
							10100111		A6		11011001	R		D9
							10101000		A7		11011010			DA
							10101001		A8		11011011			DB
							10101010		A9		11011100			DC
							10101011		AA		11011101			DD
							10101100		AB		11011110			DE
							10101101		AC		11011111			DF
							10101110		AD		11100000			E0
							10110000		AE		11100001			E1
							10110001		AF		11100010	S		E2
							10110010		B0		11100011	T		E3
							10110011		B1		11100100	U		E4
							10110100		B2		11100101	V		E5
							10110101		B3		11100110	W		E6
							10110110		B4		11100111	X		E7
							10110111		B5		11101000	Y		E8
							10111000		B6		11101001	Z		E9
							10111001		B7		11101010			EA
							10111010		B8		11101011			EB
							10111011		B9		11101100			EC
							10111100		BA		11101101			ED
							10111101		BB		11101110			EE
							11000000		BC		11101111			EF
							11000001	A	BD		11110000	0		F0
							11000010	B	BE		11110001	1		F1
							11000011	C	BF		11110010	2		F2
							11000100	D	C0		11110011	3		F3
							11000101	E	C1	F7	11110010	4		F4
							11000110	F	C2		11110101	5		F5
							11000111	G	C3		11110110	6		F6
							11001000	H	C4	F9	11110111	7		F7
							11001001	I	C5	F8	11111000	8		F8
							11001010		C6	F5	11111001	9		F9
							11001011		C7	F4	11111010			FA
							11001100		C8	F1	11111011			FB
							11001101		C9		11111100			FC
							11001010		CA		11111101			FD
							11001011		CB		11111110			FE
											11111111			FF

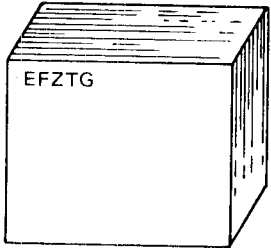

Input File

Input data is translated

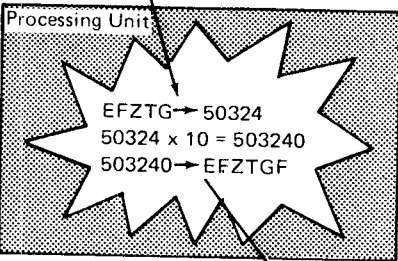

Data is translated before being put out

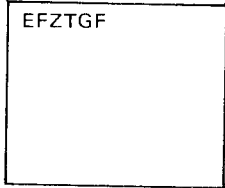

Output File

File Translation specifications used for translating both input and output files as follows:

F	I	T	Z	G	E	R	A	L	D
0	1	2	3	4	5	6	7	8	9

Figure 10-46. File Translation

If you do not specify file translation for output files, information is put out exactly as it is in the machine. If you do not intend to translate card or printer output files, be certain that all characters from the input file are translated into a value associated with a printable graphic. Any hexadecimal value which does not have an associated graphic cannot be written or punched out (Figure 10-47). If an unprintable graphic is specified to be put out, a blank appears in its place.

TRANSLATION TABLE AND ALTERNATE COLLATING SEQUENCE CODING SHEET

System/3	Entry	Replaced By/Takes Place Of
	96	

ALTERNATE COLLATING SEQUENCE CODING SHEET

System/3	Entry	Replaced By/Takes Place Of	Code	System/3 Graphic	Entry	Replaced By/Takes Place Of
			10011001		99	
			10011010		9A	
			10011011		9B	
			10011100		9C	
			10011101		9D	
			10011110		9E	
			10011111		9F	
			10100000		A0	
			10100001		A1	
			10100010		A2	
			10100011		A3	
			10100100		A4	
			10100101		A5	
			10100110		A6	
			10100111		A7	
			10101000		A8	
			10101001		A9	
			10101010		AA	
			10101011		AB	
			10101100		AC	
			10101101		AD	
			10101110		AE	
			10101111		AF	
			10110000		B0	
			10110001		B1	
			10110010		B2	
			10110011		B3	
			10110100		B4	
			10110101		B5	
			10110110		B6	
			10110111		B7	
			10111000		B8	
			10111001		B9	
			10111010		BA	
			10111011		BB	
			10111100		BC	
			10111101		BD	
			10111110		BE	
			10111111		BF	
			11000000		C0	
			11000001	A	C1	
			11000010	B	C2	
			11000011	C	C3	
			11000100	D	C4	
			11000101	E	C5	
			11000110	F	C6	
			11000111	G	C7	
			11001000	H	C8	
			11001001	I	C9	
			11001010		CA	
			11001011		CB	

C6 (F) when changed to an A0 cannot be printed for A0 has no associated graphic. The printer output file must be translated so that A0 will print out as F.

Code	System/3 Graphic	Entry	Replaced By/Takes Place Of
10011001		99	
10011010		9A	
10011011		9B	
10011100		9C	
10011101		9D	
10011110		9E	
10011111		9F	
10100000		A0	
10100001		A1	
10100010		A2	
10100011		A3	
10100100		A4	
10100101		A5	
10100110		A6	
10100111		A7	
10101000		A8	
10101001		A9	
10101010		AA	
10101011		AB	
10101100		AC	
10101101		AD	
10101110		AE	
10101111		AF	
10110000		B0	
10110001		B1	
10110010		B2	
10110011		B3	
10110100		B4	
10110101		B5	
10110110		B6	
10110111		B7	
10111000		B8	
10111001		B9	
10111010		BA	
10111011		BB	
10111100		BC	
10111101		BD	
10111110		BE	
10111111		BF	
11000000		C0	
11000001	A	C1	
11000010	B	C2	
11000011	C	C3	
11000100	D	C4	
11000101	E	C5	
11000110	F	C6	
11000111	G	C7	
11001000	H	C8	
11001001	I	C9	
11001010		CA	
11001011		CB	

Code	System/3 Graphic	Entry	Replaced By/Takes Place Of
11001100		CC	
11001101		CD	
11001110		CE	
11001111		CF	
11010000	J	DD	
11010001	J	DE	
11010010	K	DF	
11010011	L	EA	
11010100	M	EB	
11010101	N	EC	
11010110	O	ED	
11010111	P	EE	
11011000	O	EF	
11011001	R	EG	
11011010		EH	
11011011		EI	
11011100		EJ	
11011101		EK	
11011110		EL	
11011111		EM	
11100000		EN	
11100001		EO	
11100010	S	EP	
11100011	T	EQ	
11100100	U	ER	
11100101	V	ES	
11100110	W	ET	
11100111	X	EU	
11101000	Y	EV	
11101001	Z	EW	
11101010		EX	
11101011		EY	
11101100		EZ	
11101101		FA	
11101110		FB	
11101111		FC	
11110000	0	FD	
11110001	1	FE	
11110010	2	FF	
11110011			
11110100	4		
11110101	5		
11110110	6		
11110111	7		
11111000	8		
11111001	9		
11111010			
11111011			
11111100			
11111101			
11111110			
11111111			

F0

C6 (F) when changed to a F0 will print out as a zero. No further translation is necessary.

Figure 10-47. Printable Graphics



## Recording Specifications for the Translation Table

After you have written all specifications for file translation, you can record them so that they can be entered into the system. Records containing these specifications must be formatted as follows:

<i>Positions</i>	<i>Entry</i>
1-6 or 1-8	*FILES A filename
7-8	Blank if not required
9-96	Numerical values involved in translating characters

If all files (both input and output) are to be translated, use the entry \*FILES in positions 1 through 6. If only one file is translated, use that filename in positions 1 through 8. If several, but not all files, are to be translated, you must format separate records for each file.

In positions 9 through 96, there are 22 groups of four positions. Each group (9-12, 13-16, etc.) must contain two hexadecimal values involved in the translating of *one* character. The first two positions of the group are for the hexadecimal value taken from the *Entry* column of the Translation Table and Alternate Collating Sequence Coding Sheet. The last two positions are for the hexadecimal value taken from the *Replaced By* column of the coding sheet.

More than one record can be used to specify the characters which must be translated. However, each additional record must be formatted in the same way as the first. All records for one file must be grouped together. An error will occur if four records are entered in the following order:

1. FILEA
2. FILEA
3. FILEB
4. FILEA

Also, the first blank appearing in positions 9 through 96 is recognized by the computer as the end of the translation specifications. Consequently blanks should not appear between pairs of hexadecimal values.

A record containing \*\* $\emptyset$  (two asterisks and a blank) in positions 1 through 3 must precede the file translation records.

All records used for file translation except the RPG II control card must follow RPG II input, calculation, and output specifications and must precede any tables or alternate collating sequence records used.

**Character Structure**

1. Into what two portions may every column of a 96-column card and every byte in storage and on disk be divided?
2. Do all characters that have an A zone punched in the zone portion of a 96-column card have the same zone representation in storage? Why or why not?
3. Calculate the numerical value of each of the following binary numbers as recorded in one byte of storage:
  - a. 11000100.
  - b. 11010101.
  - c. 11101000.
  - d. 11110011.
4. Express the numerical value of the bytes shown in Question 3 as a pair of numbers (hexadecimal value), rather than as a single value.

**Collating Sequence of Characters**

5. What does the computer use to determine the collating sequence of characters?
6. Arrange the following characters in ascending collating sequence. Arrange the same characters in ascending collating sequence by zone and digit.

Character	Hexadecimal Value	Numerical Value
C	C3	195
/	61	97
P	D7	215
J	D1	209
*	5C	92
T	E3	227
R	D9	217
4	F4	245
&	50	80
9	F9	249
0	F0	240

**Altering the Collating Sequence**

7. Fill in the Alternate Collating Sequence Coding Sheet to:
  - a. Insert a  $\dot{U}$  between  $U$  and  $V$  (use the # sign to represent  $\dot{U}$ ).
  - b. Make a blank fall in the same sequence as zero.

Show how this information would be recorded in an alternate collating sequence record.

8. In what RPG II operations is the alternate collating sequence used?
9. Where is the sign located in a numeric field?

**Altering the Structure of Characters**

10. The TESTZ operation checks the zones of:
  - a. any position in a field.
  - b. only the low-order position in the field.
  - c. only the high-order position in a field.
11. A field may be alphameric for *any* move zone operations. Check those fields (Factor 2, Result) which *can be* numeric for the following move zone operations:

	Operation	Factor 2	Result
a.	MHLZO		
b.	MLHZO		
c.	MLLZO		
d.	MHHZO		

12. Code the calculation specifications to make the contents of a positive numeric AMTDUE field negative.

**Translating Characters**

13. What is the difference between the way the computer works with characters involved in an alternate collating sequence and the way it works with characters involved in file translation?
14. Fill in the coding forms to translate  $A$ 's to  $1$ 's and  $B$ 's to  $3$ 's. Show how these specifications would be recorded in a translation table record when all files are to be translated.

1. Zone and digit.
2. All characters which have the same zone punch in a 96-column card do not necessarily have the same zone representation in storage. There are four zone bits for each character in storage and only two zone positions in a 96-column card column. Therefore a translation must take place when the character is read. The computer checks the entire punch combination (both zone and digit) of a character to determine which bits are turned on or off in order to represent the character in storage.
3. a. 196
 
$$\begin{array}{cccc} 1 & 1 & 0 & 0 & 0 & 1 & 0 & 0 \\ 128+64+0+0 & + & 0+4+0+0 & = & 196 \end{array}$$
  - b. 213
  - c. 232
  - d. 243
4. a. C4
 
$$\begin{array}{cccc} 1 & 1 & 0 & 0 & 0 & 1 & 0 & 0 \\ C = 8+4+0+0 & + & 0+4+0+0 & = & 4 \end{array}$$
  - b. D5
  - c. E8
  - d. F3
5. The computer uses the numerical values associated with characters to determine the collating sequence of characters.

6. When characters are collated by zone and digit, they are collated in this order:

Character	Numerical Value
&	80
*	92
/	97
C	195
J	209
P	215
R	217
T	227
0	240
4	244
9	249

When characters are collated by zone the left half of the hexadecimal value is used to determine the order; when collating by digit the right half of the hexadecimal value is used. When characters are collated by zone or digit, several may hold the same position in the sequence and thus belong in the same group. Within that group they may hold any position.

Characters collated by zone are in this order:

Character	Hexadecimal Value Used
& } *	<u>50</u>
* }	<u>5C</u>
/	<u>61</u>
C	<u>C3</u>
P } *	<u>D7</u>
J } *	<u>D1</u>
R } *	<u>D9</u>
T	<u>E3</u>
4 } *	<u>F4</u>
9 } *	<u>F9</u>
0 } *	<u>F0</u>

\* Characters within brackets may be in any order since they are in the same group.

Characters collated by digit are in this order:

Character	Hexadecimal Value Used
0 } *	<u>F0</u>
& } *	<u>50</u>
/ } *	<u>61</u>
J } *	<u>D1</u>
C } *	<u>C3</u>
T } *	<u>E3</u>
4	<u>F4</u>
P	<u>D7</u>
R } *	<u>D9</u>
9 } *	<u>F9</u>
*	<u>5C</u>

\* Characters within brackets may be in any order since they are in the same group.

TRANSLATION TABLE AND ALTERNATE COLLATING SEQUENCE CODING SHEET

Code	System/3 Graphic	Entry	Replaced By/Takes Place Of	Code	System/3 Graphic	Entry	Replaced By/Takes Place Of	Code	System/3 Graphic	Entry	Replaced By/Takes Place Of	Code	System/3 Graphic	Entry	Replaced By/Takes Place Of
00110011		33		01100110		66		10011001		99		11001100		CC	
00110100		34		01100111		67		10011010		9A		11001101		CD	
00110101		35		01101000		68		10011011		9B		11001110		CE	
00110110		36		01101001		69		10011100		9C		11001111		CF	
00110111		37		01101010		6A		10011101		9D		11010000	J	DD	
00111000		38		01101011		6B		10011110		9E		11010001	J	D1	
00111001		39		01101100		6C		10011111		9F		11010010	K	D2	
00111010		3A		01101101		6D		10100000		A0		11010011	L	D3	
00111011		3B		01101110		6E		10100001		A1		11010100	M	D4	
00111100		3C		01101111		6F		10100010		A2		11010101	N	D5	
00111101		3D		01110000		70		10100011		A3		11010110	O	D6	
00111110		3E		01110001		71		10100100		A4		11010111	P	D7	
00111111		3F		01110010		72		10100101		A5		11011000	Q	D8	
01000000		40		01110011		73		10100110		A6		11011001	R	D9	
01000001		41		01110100		74		10100111		A7		11011010		DA	
01000010		42		01110101		75		10101000		A8		11011011		DB	
01000011		43		01110110		76		10101001		A9		11011100		DC	
01000100		44		01110111		77		10101010		AA		11011101		DD	
01000101		45		01111000		78		10101011		AB		11011110		DE	
01000110		46		01111001		79		10101100		AC		11011111		DF	
01000111		47		01111010		7A		10101101		AD		11100000		E0	
01001000		48		01111011		7B		10101110		AE		11100001		E1	
01001001		49		01111100		7C		10101111		AF		11100010	S	E2	
01001010	C	4A		01111101		7D		10110000		B0		11100011	T	E3	
01001011		4B		01111110		7E		10110001		B1		11100100		E4	
01001100	<	4C		01111111		7F		10110010		B2		11100101		E5	
01001101		4D		10000000		80		10110011		B3		11100110		E6	
01001110		4E		10000001		81		10110100		B4		11100111	X	E7	
01001111		4F		10000010		82		10110101		B5		11101000		E8	
01010000		50		10000011		83		10110110		B6		11101001	Z	E9	
01010001		51		10000100		84		10110111		B7		11101010		EA	
01010010		52		10000101		85		10111000		B8		11101011		EB	
01010011		53		10000110		86		10111001		B9		11101100		EC	
01010100		54		10000111		87		10111010		BA		11101101		ED	
01010101		55		10001000		88		10111011		BB		11101110		EE	
01010110		56		10001001		89		10111100		BC		11101111		EF	
01010111		57		10001010		8A		10111101		BD		11110000	0	F0	
01011000		58		10001011		8B		10111110		BE		11110001	1	F1	
01011001		59		10001100		8C		10111111		BF		11110010	2	F2	
01011010		5A		10001101		8D		11000000		C0		11110011	3	F3	
01011011		5B		10001110		8E		11000001	A	C1		11110100	4	F4	
01011100		5C		10001111		8F		11000010	B	C2		11110101	5	F5	
01011101		5D		10010000		90		11000011	C	C3		11110110	6	F6	
01011110		5E		10010001		91		11000100	D	C4		11110111	7	F7	
01011111		5F		10010010		92		11000101	E	C5		11111000	8	F8	
01100000		60		10010011		93		11000110	F	C6		11111001	9	F9	
01100001		61		10010100		94		11000111	G	C7		11111010		FA	
01100010		62		10010101		95		11001000	H	C8		11111011		FB	
01100011		63		10010110		96		11001001	I	C9		11111100		FC	
01100100		64		10010111		97		11001010		CA		11111101		FD	
01100101		65		10011000		98		11001011		CB		11111110		FE	
												11111111		FF	

ALTSEQ 40F0E57BE6E5E7E6E8E7E9E8

1 2 3 4 5 6 7 8 9 10 11 12 13 14 15 16 17 18 19 20 21 22 23 24 25 26 27 28 29 30 31 32

EAE9

33 34 35 36 37 38 39 40 41 42 43 44 45 46 47 48 49 50 51 52 53 54 55 56 57 58 59 60 61 62 63 64

65 66 67 68 69 70 71 72 73 74 75 76 77 78 79 80 81 82 83 84 85 86 87 88 89 90 91 92 93 94 95 96

97 98 99 100 101 102 103 104 105 106 107 108 109 110 111 112 113 114 115 116 117 118 119 120 121 122 123 124 125 126 127 128

B A 8 4 2 1 B A 8 4 2 1 B A 8 4 2 1 B A 8 4 2 1

1 2 3 4 5 6 7 8 9 10 11 12 13 14 15 16 17 18 19 20 21 22 23 24 25 26 27 28 29 30 31 32

B A 8 4 2 1 B A 8 4 2 1 B A 8 4 2 1 B A 8 4 2 1

33 34 35 36 37 38 39 40 41 42 43 44 45 46 47 48 49 50 51 52 53 54 55 56 57 58 59 60 61 62 63 64

B A 8 4 2 1 B A 8 4 2 1 B A 8 4 2 1 B A 8 4 2 1

65 66 67 68 69 70 71 72 73 74 75 76 77 78 79 80 81 82 83 84 85 86 87 88 89 90 91 92 93 94 95 96

IBM 3700

8. An alternate collating sequence is used only for alphameric compare operations and matching or sequence checking operations done on match fields.
9. The sign of a numeric field must be in the low-order (rightmost) position of the low-order byte.
10. C
11. 

<i>Factor 2</i>	<i>Result Field</i>
a.	X
b. X	
c. X	X
d.	
- 12.

IBM International Business Machine Corporation		RPG CALCULATION SPECIFICATIONS															Form GX21-9093 Printed in U.S.A.		
Program		Punching Instruction		Graphic		Card Electro Number										Page 1 2 of		Program Identification 75 76 77 78 79 80	
Programmer		Date		Punch															
Line	Form Type	Indicators						Factor 1	Operation	Factor 2	Result Field		Resulting Indicators			Comments			
		Control Level (L, D, L, S, L, F, SR, AN, CR)	And	And	Not	Not	Not				Name	Length	Plus	Minus	Zero				
0 1	C																		
0 2	C						OR	MHLZO'J'		AMTDUE									
0 3	C							MLLZO'J'		AMTDUE									

13. In file translation a character is actually translated into another character because the computer changes bit combinations. All affected characters are changed for the entire program. The bit combinations for characters involved in an alternate collating sequence are not changed. Bit combinations are substituted for others during sequencing operations only.

TRANSLATION TABLE AND ALTERNATE COLLATING SEQUENCE CODING SHEET

Code	System/3 Graphic	Entry	Replaced By/Takes Place Of	Code	System/3 Graphic	Entry	Replaced By/Takes Place Of	Code	System/3 Graphic	Entry	Replaced By/Takes Place Of	Code	System/3 Graphic	Entry	Replaced By/Takes Place Of
00110011		33		01100110		66		10011001		99		11001100		CC	
00110100		34		01100111		67		10011010		9A		11001101		CD	
00110101		35		01101000		68		10011011		9B		11001110		CE	
00110110		36		01101001		69		10011100		9C		11001111		CF	
00110111		37		01101010		6A		10011101		9D		11010000		DD	
00111000		38		01101011		6B		10011110		9E		11010001	J	D1	
00111001		39		01101100	%	6C		10011111		9F		11010010	K	D2	
00111010		3A		01101101	—	6D		10100000		A0		11010011	L	D3	
00111011		3B		01101110	>	6E		10100001		A1		11010100	M	D4	
00111100		3C		01101111	?	6F		10100010		A2		11010101	N	D5	
00111101		3D		01110000		70		10100011		A3		11010110	O	D6	
00111110		3E		01110001		71		10100100		A4		11010111	P	D7	
00111111		3F		01110010		72		10100101		A5		11011000	Q	D8	
01000000	Blank	40		01110011		73		10100110		A6		11011001	R	D9	
01000001		41		01110100		74		10100111		A7		11011010		DA	
01000010		42		01110101		75		10101000		A8		11011011		DB	
01000011		43		01110110		76		10101001		A9		11011100		DC	
01000100		44		01110111		77		10101010		AA		11011101		DD	
01000101		45		01111000		78		10101011		AB		11011110		DE	
01000110		46		01111001		79		10101100		AC		11011111		DF	
01000111		47		01111010		7A		10101101		AD		11100000		E0	
01001000		48		01111011	#	7B		10101110		AE		11100001		E1	
01001001		49		01111100	@	7C		10101111		AF		11100010	S	E2	
01001010	ç	4A		01111101	•	7D		10110000		B0		11100011	T	E3	
01001011	•	4B		01111110	“	7E		10110001		B1		11100100	U	E4	
01001100	<	4C		10000000		80		10110010		B2		11100101	V	E5	
01001101	l	4D		10000001		81		10110011		B3		11100110	W	E6	
01001110	+	4E		10000010		82		10110100		B4		11100111	X	E7	
01001111	l	4F		10000011		83		10110101		B5		11101000	Y	E8	
01010000	&	50		10000100		84		10110110		B6		11101001	Z	E9	
01010001		51		10000101		85		10110111		B7		11101010		EA	
01010010		52		10000110		86		10111000		B8		11101011		EB	
01010011		53		10000111		87		10111001		B9		11101100		EC	
01010100		54		10000110		88		10111010		BA		11101101		ED	
01010101		55		10001000		89		10111011		BB		11101110		EE	
01010110		56		10001001		8A		10111100		BC		11101111		EF	
01010111		57		10001010		8B		10111101		BD		11110000	0	F0	
01011000		58		10001011		8C		10111110		BE		11110001	1	F1	
01011001		59		10001100		8D		10111111		BF		11110010	2	F2	
01011010	!	5A		10001101		8E		11000000		C0		11110011	3	F3	
01011011	\$	5B		10001110		8F		11000001	A	C1	F1	11110100	4	F4	
01011100	*	5C		10010000		90		11000010	B	C2	F3	11110101	5	F5	
01011101	^	5D		10010001		91		11000011	C	C3		11110110	6	F6	
01011110	~	5E		10010010		92		11000100	D	C4		11110111	7	F7	
01011111	~	5F		10010011		93		11000101	E	C5		11111000	8	F8	
01100000		60		10010010		94		11000110	F	C6		11111001	9	F9	
01100001		61		10010100		95		11000111	G	C7		11111010		FA	
01100010		62		10010101		96		11001000	H	C8		11111011		FB	
01100011		63		10010110		97		11001001	I	C9		11111100		FC	
01100100		64		10010111		98		11001010		CA		11111101		FD	
01100101		65		10011000				11001011		CB		11111110		FE	
												11111111		FF	

**\* FILES C1F1C2F3**

1 2 3 4 5 6 7 8 9 10 11 12 13 14 15 16 17 18 19 20 21 22 23 24 25 26 27 28 29 30 31 32

33 34 35 36 37 38 39 40 41 42 43 44 45 46 47 48 49 50 51 52 53 54 55 56 57 58 59 60 61 62 63 64

65 66 67 68 69 70 71 72 73 74 75 76 77 78 79 80 81 82 83 84 85 86 87 88 89 90 91 92 93 94 95 96

97 98 99 100 101 102 103 104 105 106 107 108 109 110 111 112 113 114 115 116 117 118 119 120 121 122 123 124 125 126 127 128

B A 8 4 2 1 1 2 3 4 5 6 7 8 9 10 11 12 13 14 15 16 17 18 19 20 21 22 23 24 25 26 27 28 29 30 31 32 B A 8 4 2 1

33 34 35 36 37 38 39 40 41 42 43 44 45 46 47 48 49 50 51 52 53 54 55 56 57 58 59 60 61 62 63 64 B A 8 4 2 1

65 66 67 68 69 70 71 72 73 74 75 76 77 78 79 80 81 82 83 84 85 86 87 88 89 90 91 92 93 94 95 96

IRM 3700





**CHAPTER 11 DESCRIBES:**

How to use the DEBUG operation.

Format of records created by DEBUG.

**BEFORE READING THIS CHAPTER YOU SHOULD BE ABLE TO DESCRIBE:**

RPG II logic for indicators (see *Chapter 1, RPG II Logic*).

**AFTER READING THIS CHAPTER YOU SHOULD BE ABLE TO:**

Code the Control Card and Calculation specifications necessary to employ the DEBUG operation.

Place the DEBUG operation within your program so that it will provide meaningful data.

*Note:* You can use the review questions at the end of this chapter to test your comprehension of this topic. Answers follow the review questions.

## INTRODUCTION

A program that you write may not always work perfectly the first time or even the first few times it is run. The reason for this is that the program contains errors – errors that you were not aware you were making when you wrote the program. Some of the errors you can make are easy to find; others may be very difficult to find. Nevertheless, they all have to be corrected. But how do you do this? Where do you start?

Just knowing the types of errors which are commonly made can give you a hint as to what you should check. Most of the errors made fall into one of the following categories:

- Incorrect use of RPG II entries on the specifications sheets.
- Errors in describing input data or the format of output data.
- Errors in specifying the calculation operations.
- Specifying calculation operations in the wrong sequence.

The RPG II Compiler, when compiling your program, will diagnose the specifications to see if they contain errors. If they do, the compiler will print messages telling you the errors made. In this way, you can find errors made in the specifications.

## USING THE DEBUG FUNCTION

You may, however, have made all correct entries on the sheets and still get the wrong results. What can you do then? You can, of course, check through your work. But this does not always show you where the error(s) lies.

Sometimes, the specifications you write will not cause the computer to do what you think they will. It is often possible to miss an error because you assume that a statement or group of statements needed to perform a certain task work correctly, when, in fact, they do not. For example, you may pass statement 06 believing it is correct when it is not and spend hours looking for errors in the rest of the statements which are really correct.

It would certainly be helpful to you to find out just how far along in your program everything is working correctly. But how can you find out information your program is working with at various points in your program?

The RPG II language has a special operation code which shows you some of the information the computer is working with. This code is known as the DEBUG code. The code received its name from the slang term “bugs” which is used to mean errors in a program. To debug a program, therefore, means to get all the errors out of it. This is what the DEBUG code helps you do.

The DEBUG code will cause a maximum of two different types of records to be printed or punched out showing you:

- What data is contained in a specified field.
- What indicators are on.

One of the most common errors found in a program is the incorrect use of indicators. If the programmer fails to thoroughly understand RPG II logic, he may condition an operation using an indicator which he thinks is on when it is really not. Thus the program does not work properly.

If, at any point in your calculations, you want to check to see if you are using indicators properly you can specify DEBUG. This code will cause a record to be put out showing what indicators are on at the point DEBUG is specified. If you wish to know the contents of a field in addition to knowing what indicators are on, you can also specify so in the DEBUG statement. A second record type will then be put out showing the contents of the field.

## Specifications for DEBUG

When using DEBUG, the first specification which you must make is on the control card. A 1 in column 15 indicates that DEBUG is going to be used (see Figure 11-1). If this column is left blank, all DEBUG statements will be treated as comments.

Then in columns 28-32 (Operation) on the Calculation sheet, specify the code DEBUG. You may specify it at any point in the calculations and as many times as you want.

For each DEBUG statement, enter in columns 33-42 (Factor 2) the name of the file on which DEBUG records will be written or punched (see Figure 11-1). Use the file name previously assigned on the File Description sheet. The same output file must be used for all DEBUG operations in a program.



The entries just described will give you a record showing what indicators are on. If you also want to know the contents of a field, you must make another entry: The name of the field whose value you wish to know must be entered as the Result Field in Columns 43-48 (see Figure 11-2, insert A).

Columns 18-27 (Factor 1) are optional. If you have several DEBUG statements, you may wish to know which records were caused by a particular DEBUG statement. You can name the DEBUG statement by entering a literal in columns 18-27. This name will then be included in the records which the statement causes to be put out (see Figure 11-2, insert B).

Columns 7-17 may contain any valid conditioning indicator. The external indicators U1-U8 are most often used here. They make the DEBUG statement optional. Through their use you can establish, prior to a run, whether or not you wish to use DEBUG (see Chapter 5, *Controlling Operations in an RPG II Program* for uses of U1 to U8). Columns 53-59 cannot be used for the DEBUG statement.

### Format of Records Created by DEBUG

Two records may be created by the DEBUG operation. Record 1 is required; Record 2 is optional. Record 1 (Figure 11-3) will look like this:

Positions	Entry
1-8	DEBUG =
9-16	The name entered in Factor 1 of the debug statement. These columns will be blank if no entry is found in Factor 1.
17-18	Blank
19-33	INDICATORS ON =
34	Blank
35-37, 38-40, etc.	Name of the indicators which are on. Each indicator is followed by a blank. If a large number of indicators are on, more than one record may be required to show all indicators.

C		Indicators		Factor 1		Operation		Factor 2		Result Field		Resulting Indicators		Comments	
Line	Form Type	And	And							Name	Length	Plus	Minus		Zero
0 1	C														
0 2	C														
0 3	C														
0 4	C														
0 5	C														
0 6	C														

Figure 11-2 shows a sample of the RPG CALCULATION SPECIFICATIONS form. The form includes fields for Program, Programmer, Date, Punching Instruction, Graphic, Punch, Card Electro Number, Page, and Program Identification. The main table has columns for Line, Form Type, Indicators (And, And), Factor 1, Operation, Factor 2, Result Field (Name, Length), Resulting Indicators (Arithmetic, Plus, Minus, Zero, Compare, 1 > 2, 1 < 2, 1 = 2, Lookup, Factor 2), and Comments. The sample entries are:

- Line 0 1: Form Type C, Indicators And, Operation DEBUGOUTFILE, Result Field NAME, Length FIELD, Comments PRINT IND, FIELD
- Line 0 2: Form Type C, Indicators And, Operation DEBUGOUTFILE, Result Field NAME, Length FIELD, Comments NAME DEBUG

Figure 11-2. Additional Entries Which Can Be Made for DEBUG

Record 2 (Figure 11-3) will look like this:

Positions	Entry
1-14	FIELD VALUE =
15 –	The contents of the field named as the result field in the debug statement. If the field is rather large, only 80 of the rightmost characters are displayed.

### Getting Results from DEBUG

DEBUG will not automatically provide you with the specific reason your program is in error. But by showing the indicator setting and contents of fields at various points, it can give you a clue as to where the error lies. From there, you will have to work through the logic of sections in your program to find specific *bugs*.

### Placement of DEBUG

DEBUG statements can be placed anywhere in the calculations. However much thought should be given to their position. If they are not placed in proper positions, they may give misleading information and be of no help at all. For

example, if you are concerned about the status of an indicator at a certain point in your program, be sure to position DEBUG so that the indicator has no chance to change before it is displayed.

If you want to find out if a statement or group of statements is working correctly you must know what is in the field involved immediately *before* and *after* the statement(s). This means placing DEBUG before and after the statement(s) you are checking. In order to determine if the results obtained from these statements are correct, you will have to manually make the same calculations and compare the two results. In this case, however, you must make certain your own calculations are correct. Much time can be wasted trying to make the computer arrive at the same wrong answer you have calculated.

### Making Your Program Work for All Cases

Be certain that you test your program to see that it will handle correctly all possible situations which might arise. If you test for only one or two situations, you can be sure your program works only for those situations. This means that the data you use to test your program be *complete* and valid so that it tests all possible situations. In this way, you can be sure your program can handle all situations without encountering hidden 'bugs'.

Record 1

```
DEBUG = DEBUG 1      INDICATORS ON = 20 42 02 11 MR
```

Record 2

```
FIELD VALUE = 005648219R
```

Figure 11-3. Format of DEBUG Records



1. What does DEBUG do in an RPG II program?
2. Write a DEBUG statement to display on the file called OUTFILE a field called ANSWER and the indicators that are on at this point. Identify the DEBUG records with the constant - TEST1. What entries in other specification sheets must be made?



# Answers To Review 11

1. DEBUG allows you to display the contents of a data field in your program and to list the indicators that are on.
2. A 1 must be entered in column 15 of the RPG II control card.

IBM International Business Machine Corporation		RPG CALCULATION SPECIFICATIONS																				Form GX21-9093 Printed in U.S.A.	
Program _____		Punching Instruction _____				Graphic _____				Card Electro Number _____				Page <input type="text" value="1"/> of <input type="text" value="2"/>		Program Identification <input type="text" value="75"/> <input type="text" value="76"/> <input type="text" value="77"/> <input type="text" value="78"/> <input type="text" value="79"/> <input type="text" value="80"/>							
Programmer _____		Date _____		Punch _____				Graphic _____				Card Electro Number _____											
Line	Form Type Control Level (L,G,L1,9, LR,SR,AN/OR)	Indicators						Factor 1	Operation	Factor 2	Result Field		Decimal Positions Half Adjust (H)	Resulting Indicators			Comments						
		And	And								Name	Length		Plus	Minus	Zero							
0 1	C							'TEST1'	DEBUG	OUTFILE	ANSWER												
0 2	C																						
0 3	C																						
0 4	C																						

- \*(asterisk; star), printing on cards 4-3
- \*\* (look ahead fields) 5-21
- \*PLACE 3-19
  - conditioning by indicators 3-22
  - used with EXCPT 7-26
- \*PRINT (unformatted printing on cards) 4-6
  
- accumulating totals 5-59
- advancing printer forms 3-6
- aligning printer forms 3-12
- altering character structure 10-38
- altering the order of file processing 7-2
- alternate collating sequence 10-27
- alternating format
  - arrays 9-3
  - tables 8-12
- alternating processing of files 7-4
- ALTSEQ card 10-38
- arithmetic operations
  - using table results 5-13
- arrays
  - accumulating groups of totals 9-14
  - adding elements (XFOOT) 9-8
  - array to array calculations 9-4
  - calculations with single fields or constants 9-7
  - compile time arrays 9-35
  - defining 9-2
  - of different lengths 9-7
  - editing 9-11
  - execution time 9-38
  - indexing 9-20
  - loading
    - compile time 9-36
    - execution time 9-38
    - pre-execution time 9-36
  - LOKUP 9-27
  - MOVEA operation 9-44
  - operation codes, restrictions 9-7
  - output
    - during a search 9-34
    - of an entire array 9-9
    - of individual elements 9-22
  - pre-execution time 9-36
  - referencing all elements 9-4
  - referencing individual elements 9-19
  - referencing part of an element 9-23
  - storing data into (*see* loading)
  - when to use array instead of table 9-2
  - XFOOT 9-8
- artificial control break (L0) 5-56
- asterisks, punctuating with 3-16
- automatic overflow (page formatting) 3-2
  
- balances (*see* editing)
- BEGSR (begin subroutine) operation code 5-48
- binary field operations 5-67
  - BITOF operation code 5-67
  - BITON operation code 5-67
  - TESTB operation code 5-68
- binary format 10-19
- BITOF (set bits off) operation code 5-67
- BITON (set bits on) operation code 5-67
- bits (numerical value of) 10-13
- blank after function (with resulting indicators) 1-31
- branching in calculations
  - backwards 5-42
  - bypassing calculations 5-36
  - for an error condition 5-41
  - GOTO operation code 5-36
  - in a matching records job 5-41
  - repeating calculations 5-42
  - TAG 5-36
  - when different record types require different operations 5-41
- bypassing calculations 5-36
- bytes, definition 10-4
  
- calculation specifications
  - using results of arithmetic operations 5-13
  - for arrays
    - accumulating groups of totals 9-14
    - adding all fields (XFOOT) 9-8
    - array to array 9-4
    - using single fields or constants 9-7
  - binary field operations 5-67
  - branching 5-36
  - conditioning 5-7, 5-12, 5-59
  - subroutines 5-44
  - used to control input and output 7-1
  - using table data 8-14
  - (*see also* individual operation codes)
- card column structure 10-2
- card path, MFCU (diagram) 5-17
- card type, stacker selection based on 4-15
- cards, printing on 4-2
- cards, stacker selection of 4-14
- carriage tractors (*see* dual feed carriage)
- catch-all record identifying indicator 2-15
- CHAIN operation code (*see IBM System/3 RPG II Disk File Processing Programmer's Guide*, GC21-7566)
- changing field type 5-34
- changing array data
  - compile time 9-36
  - execution time 9-38
  - pre-execution time 9-36
- changing table data
  - compile time 8-22
  - pre-execution time 8-26

- character set 10-2
- | character groups with zones that test equal 10-9
- character structure
  - altering 10-39
  - on cards 10-6
  - negative number 10-3
  - in storage (core or disk) 10-4
- characters, translating 10-44
- checking for duplicate records
  - using look ahead 5-20
  - using move operations 5-31
- checking sequence of records
  - using match fields 6-2
  - using move operations 5-31
- checking sequence of record types 2-6
- codes, use in file translation 10-44
- collating sequence
  - altering of 10-30
  - ALTSEQ card 10-38
  - specifications 10-38
  - by zone or digit 10-25
- combined file
  - definition 4-8
  - used with look ahead 5-28
  - used to read and punch the same card 4-8
  - used with stacker selection 4-14, 4-17
- compare operations
  - using the results 5-14
- compile time arrays 9-35
- compile time tables 8-25
- conditioning calculations
  - based on information in next card 5-17
  - based on LOKUP operation 8-14, 9-27
  - based on results of other calculations 5-12
  - using external indicators 5-7
  - using halt indicators 5-2
  - using overflow indicators 5-11
- conditioning use of input files 2-19, 2-22
- conditioning operations when storing array data 9-49
- conditioning output operations 5-2
- conditioning subroutine statements 5-54
- consecutive file (*see IBM System/3 RPG II Disk File Processing Programmer's Guide, GC21-7566*)
  - in calculations with arrays 9-7
  - use in editing 3-18
- control break 2-2
  - artificial (L0) 5-56
- control card
  - alternate collating sequence 10-38
  - file translation 10-48
  - setting external indicators (Model 10 Card System) 2-21
- control fields
  - definition 1-5
  - | logic for initial program cycles 1-7
  - with field record relation 2-18
  - with match fields 6-34
  - split control fields 2-5
- control group
  - determining first only record in 5-26
  - determining last record in 5-28
  - incorrect records in 2-11
  - number of each record type in 2-11
  - optional record types in 2-11
  - order of record types in 2-6
  - sequenced and unsequenced record types 2-14
  - unexpected or unused record types in 2-14
- control level indicators
  - artificial control break (L0) 5-56
  - to condition calculations 5-59
  - to condition subroutines 5-54
  - first cycle difference 1-7
  - general use 1-5
  - | group printing 5-59
  - special use 5-55
- controlling printer output 3-1
- cycle, RPL II logic 1-1
  - first cycle 1-7
  - last cycle 1-16
- dashes, punctuating with 3-16
- data structure 10-1
  - binary format 10-20
  - negative numbers 10-3
  - packed decimal format 10-19
  - unpacked decimal format 10-19
- DEBUG function 11-1
  - format of debug records 11-4
- decimal positions in table entries 8-7
- demand files (READ operation) 7-24
  - end-of-file indicator 7-24
  - coding rules and considerations 7-26
- designing table input records 8-4
- detail time
  - logic 1-6
  - operations 1-4
- device name, dual carriage printers
  - PRINTER; PRINTR2 3-28
  - TRACTR1; TRACTR2 3-29
- digit, collating by 10-25
- digit portion of character
  - card 10-2
  - disk 10-4
- direct files (*see IBM System/3 RPG II Disk File Processing Programmer's Guide, GC21-7566*)
- dollar sign, punctuating with 3-14
  - fixed 3-14
  - floating 3-14
- dual feed carriage printer 3-27
- dual input/output areas 5-69
- dummy match field 6-10
- duplicate information, printing (\*PLACE) 3-19
  - duplicating constants 3-24
- duplicate records, checking for 5-20
- edit codes 3-12
  - chart 3-13
- edit words 3-12, 3-16
- editing
  - definition 3-12
  - arrays 9-11

- with asterisks 3-16
- with blanks 3-18
- on cards 4-8
- with constants 3-18
- with dashes 3-16
- end position 3-19
- fixed dollar sign 3-14
- floating dollar sign 3-14
- zero balances 3-13
- zero suppression 3-13
- element
  - array 9-2
  - table 8-2
- end-of-file
  - input file 2-23
  - FORCE operation 7-11
  - multi-file processing 6-30
  - READ operation (demand files) 7-24
- end of job (*see* end-of-file external indicator; halt indicator; last record indicator)
- end position
  - when editing 3-19
  - when using \*PLACE 3-22
- ENDSR operation code 5-48
- entries (*see* table entries)
- equal search condition 8-19
- error conditions 5-41
  - (*see also* halt indicators, H1-H9)
- errors in program, finding 11-1
- EXCPT operation code 7-26
  - conditioning EXCPT 7-29
  - used in a loop 5-42
  - with \*PLACE 7-26
- execution time arrays 9-38
- EXSR operation code 5-48
- extension specifications
  - for arrays 9-2
  - for one table 8-5
  - for two tables 8-13
- external indicators (U1-U8)
  - conditioning input files and calculation operations 5-7
  - conditioning input files 2-19, 2-22
  - conditioning input files and output operations 5-8
  - conditioning output file and output operations 5-9
  - conditioning output operations only 5-11
  - setting on Model 10 Card System (indicator control card) 2-21
  - setting on Model 10 Disk System and Model 15 (SWITCH OCL statement) 2-21
  - setting on Model 6 (SWITCH keyword) 2-22
- fetch overflow 3-8
- field indicators, logic 1-25
- field record relation
  - with control fields 2-18
  - with match fields 6-8
  - OR relationship with 2-16
- field scanning 9-23
- file designation
  - determining whether file should be primary or secondary 6-38
- file translation 10-42
- final totals, printing 5-59
- first page (1P) indicator, logic 1-13
- first program cycle 1-7
- fixed dollar sign 3-14
- floating dollar sign 3-14
- FORCE operation code 7-2
  - altering the order of file processing 7-2
  - alternating processing between two files 7-4
  - controlling number of FORCE operations 7-9
  - controlling processing at end-of-file 7-11
  - effect on MR 7-22
  - with look ahead 7-15
  - performing matching records without match fields 7-15
  - use of trailer card 7-12
- format of data (*see* data structure)
- format of DEBUG records 11-4
- formatted printing on cards 4-2
- formatting reports 3-2
- forms advance (fetch overflow) 3-12
- forms alignment 3-12
- forms length 3-4
- GOTO operation code 5-36
- group indication 2-2
- group printing 5-59
- halt indicators
  - conditioning operations 5-2
  - logic cycle 1-35
- halting
  - for record out of sequence in a control group 2-10
  - for record out of sequence in a file 6-5
  - for errors in data 5-2
  - for incorrect record type in a control group 2-13
- hexadecimal values (chart) 10-18
- high search condition
  - arrays 9-31
  - tables 8-19
- increasing speed of input and output (dual I/O area) 5-69
- indexing arrays 9-20
- indicators
  - definition 1-2
  - control level (L1-L9)
    - function 1-5
    - special uses 5-55
  - to control calculations and output 5-2
  - external (U1-U8)
    - conditioning operations 5-7
    - setting 2-21
  - field indicators, logic 1-25
  - field record relation 2-16
  - first page (1P), logic 1-13
  - halt indicators (H1-H9)
    - logic 1-35
    - to prevent operations on an error 5-2

- last record (LR), logic 1-16
- L0 5-55
- matching records (MR), logic 1-42
- overflow (OA-OG, OV) 3-4
- record identifying, logic 1-19
- resulting
  - logic 1-31
  - use with arithmetic operations 5-13
  - setting indicators (SETON, SETOF) 1-43
- indicator control card (Model 10 Card System) 2-21
- input areas, dual 5-69
- input data, storing in execution time arrays 9-38
- input files
  - conditioning use of 2-19
  - merging input and output cards 4-27
  - stacker selection 4-14
- input, programmed control of 7-1
- input records
  - arrays 9-35
  - tables 8-4
- interpreting punched data 4-2

- last record (LR) indicator, logic 1-16
- level indicators (*see* control level indicators)
- line counter specifications 3-4
- loading arrays
  - compile time 9-36
  - execution time 9-38
  - pre-execution time 9-26
- loading tables
  - compile time 8-25
  - pre-execution time 8-26
- logic, basic data processing 1-2
- logic, RPG II (*see* RPG II logic)
- LOKUP operation code
  - arrays 9-27
  - with one table 8-7
  - with two tables 8-14
- look ahead feature
  - checking for duplicates 5-20
  - with combined or update files 5-28
  - finding last record in group 5-28
  - with FORCE 7-15
  - logic cycle for 5-23
  - with MFCU files 5-17
  - records available 5-18
  - to find single record groups 5-26
  - specifications 5-20
- loop in calculations 5-42
- loop with EXCPT 5-42
- low search condition
  - arrays 9-33
  - tables 8-20
- LR (last record) indicator 1-16
- L0 (internal control level indicator) 5-55
- L1-L9 indicators (*see* control level indicators)

- match fields
  - assigning, rules for 6-7
  - with control fields 6-34
  - definition 6-1
  - dummy match field entry 6-10
  - with field record relation 6-8
    - rules 6-10
  - in different locations in a file 6-26
  - M1-M9 entries 6-2
  - sequence checking with
    - one record type in file 6-2
    - more than one record type 6-6
- matching records
  - definition 6-2
  - with control fields 6-34
  - end-of-file with 6-30
  - first cycle 6-14
  - performed using FORCE with look ahead 7-15
  - logic cycle 6-14, 6-38
  - more than one matching secondary 6-12
  - more than one record type in a file 6-26
  - one record type in each file 6-12
  - processing records without match fields 6-29
  - record identifying indicator with 6-14
  - total operations with 6-14, 6-34
- matching records indicator (*see* MR)
- merging input and output file cards 4-24
- MFCM output operations 4-1
  - printing on cards 4-2
    - formatted 4-5
    - unformatted (\*PRINT) 4-6
  - punched output 4-2
    - combined files 4-8
    - stacker selection 4-14
- MFCU files, look ahead with 5-17
- MFCU output operations 4-1
  - printing on cards 4-2
    - formatted 4-3
    - unformatted (\*PRINT) 4-6
  - punched output 4-2
    - combined files 4-8
    - interpreting punched data 4-2
    - summary punching 4-2
  - stacker selection 4-14
- MHHZO (move high order zone to high order zone)
  - operation code 10-40
- MHLZO (move high order zone to low order zone)
  - operation code 10-40
- MLHZO (move low order zone to high order zone)
  - operation code 10-40
- MLLZO (move low order zone to low order zone)
  - operation code 10-40
- modifying table contents 8-22
- MOVEA operation code 9-44
- move zone operation codes 10-39
  - example 10-41
  - field format 10-41
  - model character 10-42
  - operation codes 10-41
- moving data
  - to change the field type 5-34
  - MOVE operation code 5-29
  - MOVEL operation code 5-29

- to sa information 5-31
- to separate fields into two parts 5-33
- in a table entry 8-22
- MR (matching records) indicator
  - effect of FORCE on 7-22
  - logic cycle 1-42
  - used to condition subroutines 5-54
  - when on 6-17
  - when turned on 6-14, 6-22
- multifile processing
  - definition 6-2
  - end-of-file specification 6-30
  - general description of logic 1-42
  - (*see also* match fields; matching records; MR indicator)
- M1-M9 (*see* match fields)
  
- negative numbers, structure of 10-3
- number of each record type in a control group 2-11
- numerical values
  - of bit combinations 10-12
  - of zone and digit portions 10-15
  
- object program cycle (*see* RPG II logic)
- operation codes
  - BEGSR 5-48
  - BITOF 5-67
  - BITON 5-67
  - DEBUG 11-1
  - ENDSR 5-48
  - EXCPT 7-26
    - used in loop 5-42
  - EXSR 5-49
  - FORCE 7-2
  - GOTO 5-36
  - LOKUP 8-14, 9-27
  - MHHZO 10-40
  - MHLZO 10-40
  - MLHZO 10-40
  - MLLZO 10-40
  - MOVE 5-29
  - MOVEA 9-44
  - MOVEL 5-29
  - READ 7-22
  - TAG 5-36
  - TESTB 5-68
  - TESTZ 5-14
  - XFOOT 9-8
- operations
  - arithmetic, using results of 5-13
  - binary field 5-59
  - compare, using results of 5-14
  - controlling with look ahead 5-17
  - detail 1-4
  - total 1-4
- optional record types in a control group 2-11
- OR relationship 2-15
  - with field record relation 2-16
  - with stacker selection 4-15
- output-format specifications
  - arrays
    - during an array search 9-34
    - entire array 9-9
    - individual fields 9-22
  - dual feed carriage printer 3-27
  - stacker selection using 4-15
  - using table data 8-14
- output areas, dual 5-69
- output cards
  - merging with input cards 4-19
  - stacker selecting 4-17
- output operations
  - conditioned by external indicators 5-8
  - MFCU 4-1
- output, printer 3-1
- output, programmed control of 7-1
- output, table 8-28
- overflow
  - automatic 3-2
  - fetch overflow 3-8
  - calculations with 5-11
  - indicators 1-41, 3-2
  - line counter specifications 3-4
  - logic 1-41
- overflow line, standard 3-2
- overlay, controlling with subroutines 5-54
  
- packed decimal format 10-19
- \*PLACE
  - with constants 3-24
  - different spacing 3-23
  - with EXCPT 5-42
  - formation of print lines 3-22
  - with indicators 3-24
  - specifications 3-22
- pre-execution time arrays 9-36
- pre-execution time tables 8-25
- preventing operations when an error occurs 5-2
- primary files, determining whether files should be primary or secondary 6-38
- primary tractor (dual printer files) 3-37
- PRINTER device name 3-28
- \*PRINT 4-6
  - Printer files, dual 3-27
  - printer forms alignment 3-12
  - printer forms, designing 3-12
  - printer output, controlling 3-1
  - printing duplicate information 3-19
  - printing on cards 4-2
  - printing only final totals 5-59
  - printing over the perforation 3-6
  - PRINTER2 device name 3-28
  - print-head (MFCM) 4-5
  - processing order of files (*see* matching records; multifile processing)
  - program cycle 1-2
  - (*see also* RPG II logic)
  - programmed control of input and output 7-1

- program errors, finding (*see* DEBUG)
- punch combinations 10-2
- punched output (MFCU) 4-2
  - summary punching 4-2
- punching into a blank card 4-11
- punching into the same card that is read 4-8
- punctuating a field (*see* editing)
  
- reading and punching the same card 4-8
- READ operation code 7-22
- record identification code 2-6
- record identifying indicators
  - catch-all indicator 2-15
  - in field record relation 2-15
  - logic for 1-19
  - with matching records 6-14
  - in sequence checking record types 2-9
- recording specifications for an altered collating sequence 10-38
- records, designing table input 8-4, 8-11
- record types
  - branching in calculations for different 5-41
  - OR relationship of 2-15
  - sequence checking of 2-9
- reducing coding and storage requirements
  - in calculations (subroutines) 5-44
  - in describing similar or identical records (field record relation) 2-15
  - when printing duplicate information 3-19
  - when punching and printing cards 4-8
- reducing job time
  - dual input/output areas 5-69
- referencing individual array elements 9-19
- related tables 8-13
- repeating calculations
  - by branching 5-42
  - using subroutines 5-45
- repeating the first print line 3-12
- repetitive output (EXCPT operation) 7-26
- resulting indicators
  - with arithmetic operations 5-13
  - logic for 1-31
  - with LOKUP 8-7, 9-27
  - with READ 7-22
  - with TESTB 5-68
- rolling of totals (arrays) 9-14
- RPG II logic
  - detail time 1-6
  - fetch overflow 3-8
  - first program cycles 1-7
  - related to indicators 1-7
    - field indicators 1-25
    - first page (1P) indicator 1-13
    - halt indicators (H1-H9) 1-35
    - last record indicator (LR) 1-16
    - matching records indicator (MR) 1-42, 6-14
    - overflow 1-41
    - record identifying indicators 1-19
    - resulting indicators 1-31
    - setting indicators 1-43
    - total time 1-6
  - saving disk storage space
    - binary date format 10-20
    - packed decimal format 10-19
  - saving information by move operations 5-29
  - scanning fields 9-23
  - searching arrays 9-27
    - determining search success 9-30
    - for a particular element 9-27
    - output during search 9-34
    - starting the search at a particular element 9-28
    - referencing the element found 9-31
  - searching tables 8-2
    - for high, low, or equal 8-19
    - referencing the data found 8-16
  - secondary file
    - determining whether a file should be 6-38
  - secondary tractor (dual carriage printer) 3-27
  - selecting a stacker on the MFCU 4-14
  - separating a field into two parts 5-33
  - sequence checking
    - by calculation specifications 5-31
    - of a file using match fields 6-2
    - of record types in a control group 2-6
  - sequential disk file (*see IBM System/3 RPG II Disk File Processing Programmer's Guide*, GC21-7566)
  - setting external indicators 2-21, 2-22
  - setting indicators (SETON, SETOF) 1-43
  - SETOF operation code 1-43
  - SETON operation code 1-43
  - short tables 8-23
  - skipping 3-29
  - skipping calculations (branching) 5-36
  - spacing 3-29
  - split control fields 2-6
    - with field record relation 2-18
  - SR (subroutine) lines 5-48
  - stacker selection 4-14
    - at total time 4-17, 5-10
    - of combined file cards 4-17
    - of input cards
      - based on calculations 4-15
      - based on card type 4-15
    - of output file cards 4-17
    - of unmatched records 6-24
  - standard forms length 3-2
  - standard overflow line 3-2
  - storing data into execution time arrays 9-38
  - structure of characters (*see* character structure)
  - subroutines
    - calling 5-48
    - conditioning 5-54
    - fields available 5-49
    - limitations 5-52
    - overlays 5-52
    - repeating calculations 5-45
    - specifications 5-48
    - valid operations in 5-52
  - subtotals (group printing) 5-59

- | summarizing data (group printing) 5-59
- summary punching 4-2
  - example 5-10
- suppressing leading zeros 3-13
- SWITCH keyword (Model 6) 2-22
- SWITCH OCL statement (Model 10 Disk System and Model 15) 2-21
- switches
  - binary field operations 5-67
  
- tables 8-1
  - assigning table names 8-6
  - binary table data 8-7
  - compared to arrays 9-2
  - compile time 8-25
  - definition 8-2
  - describing input records 8-5
  - designing input records
    - one table 8-4
    - two tables 8-11
  - entries with decimal positions 8-7
  - length of entry 8-6
  - loading 8-25
  - modifying contents of 8-22
  - moving data in an entry 8-22
  - number of entries per input record 8-4, 8-6
  - number of entries per table 8-6
  - number of input records required 8-4
  - output 8-28
  - packed table data 8-7
  - pre-execution time 8-25
  - related 8-8
  - searching 8-2, 8-14
  - sequence 8-7
  - short 8-23
- TAG operation code 5-36
- TESTB operation code 5-60
- testing the contents of a field 5-12
- TESTZ operation code 5-14
  - | character groups with zones that test equal (table) 10-10
- total operations
  - logic 1-6, 6-38
  - with matching records 6-14, 6-34
- tractors (dual carriage printers) 3-27
- TRACTR1 device name 3-29
- TRACTR2 device name 3-29
- trailer card
  - use in force operation 7-12
- translating characters
  - coding for 10-44
  - forms used 10-44
  
- unexpected record types in a group 2-14
- unformatted printing on cards (\*PRINT) 4-4
- unmatched record
  - stacker selection of 6-24
- unsequenced record types in a control group 2-14
  
- update files, look ahead with 5-28
- U1-U8 indicators 2-19
  
- XFOOT operation code 9-8
  
- zero balances 3-13
- | zero, negative 10-3
- zero suppression 3-13
- zone portion of character
  - collating by 10-25
  - testing (TESTZ) 5-14
- | zones that test equal (table) 10-10
- zone punches 10-2
  
- 0A-0G, 0V indicators (*see* overflow indicators)
- 01-99 indicators (*see* record identifying indicators; resulting indicators; field indicators)
- 1P indicator logic for 1-13
- | 1403 Printer 3-2
- 2222 Printer 3-27
- | 2560 MFCM 4-2
- 5203 Printer 3-27
- | 5213 Printer 3-2
- | 5424 MFCU 4-2





# READER'S COMMENT FORM

IBM System/3  
RPG II Additional Topics  
Programmer's Guide

GC21-7567-2

## YOUR COMMENTS, PLEASE . . .

Your comments assist us in improving the usefulness of our publications; they are an important part of the input used in preparing updates to the publications. All comments and suggestions become the property of IBM.

Please do not use this form for technical questions about the system or for requests for additional publications; this only delays the response. Instead, direct your inquiries or requests to your IBM representative or to the IBM branch office serving your locality.

Corrections or clarifications needed:

*Page*            *Comment*

Please include your name and address in the space below if you wish a reply.

- Thank you for your cooperation. No postage necessary if mailed in the U.S.A.

Cut Along Line

IBM System/3 RPG II Additional To,

(File No. S3-28)

Printed in U.S.A.

GC21-7567-2

Fold

Fold



NO POSTAGE  
NECESSARY  
IF MAILED  
IN THE  
UNITED STATES



**BUSINESS REPLY MAIL**  
FIRST CLASS PERMIT NO. 40 ARMONK, N.Y.

POSTAGE WILL BE PAID BY ADDRESSEE:

IBM Corporation  
General Systems Division  
Development Laboratory  
Publications, Dept. 245  
Rochester, Minnesota 55901

Fold

Fold



International Business Machines Corporation  
General Systems Division  
875 Johnson Ferry Road N. E.  
Atlanta, Ga. 30342

IBM World Trade Corporation  
821 United Nations Plaza, New York, New York 10017  
(International)

# READER'S COMMENT FORM

IBM System/3  
RPG II Additional Topics  
Programmer's Guide

GC21-7567-2

## YOUR COMMENTS, PLEASE . . .

Your comments assist us in improving the usefulness of our publications; they are an important part of the input used in preparing updates to the publications. All comments and suggestions become the property of IBM.

Please do not use this form for technical questions about the system or for requests for additional publications; this only delays the response. Instead, direct your inquiries or requests to your IBM representative or to the IBM branch office serving your locality.

Corrections or clarifications needed:

<i>Page</i>	<i>Comment</i>
-------------	----------------

Please include your name and address in the space below if you wish a reply.

- Thank you for your cooperation. No postage necessary if mailed in the U.S.A.

Cut Along Line

Fold

Fold



NO POSTAGE  
NECESSARY  
IF MAILED  
IN THE  
UNITED STATES

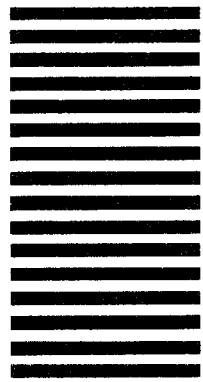

**BUSINESS REPLY MAIL**  
FIRST CLASS PERMIT NO. 40 ARMONK, N.Y.

POSTAGE WILL BE PAID BY ADDRESSEE:

IBM Corporation  
General Systems Division  
Development Laboratory  
Publications, Dept. 245  
Rochester, Minnesota 55901

Fold

Fold

IBM System/3 RPG II Additional Tables (File No. S3-28) Printed in U.S.A. GC21-7567-2



**International Business Machines Corporation**  
General Systems Division  
875 Johnson Ferry Road N. E.  
Atlanta, Ga. 30342

**IBM World Trade Corporation**  
821 United Nations Plaza, New York, New York 10017  
(International)



# Technical Newsletter

This Newsletter No. GN21-5389  
Date 24 May 1976  
Base Publication No. GC21-7567-2  
File No. S3-28  
Previous Newsletters None

## IBM System/3 RPG II Additional Topics Programmer's Guide

© IBM Corp. 1971, 1974

This technical newsletter provides replacement pages for the subject publication. Pages to be inserted and/or removed are:

i, ii	5-9, 5-10	9-1, 9-2
1-5, 1-6	5-49, 5-50	9-27, 9-28
3-21, 3-22	5-67, 5-68	9-41 through 9-44
3-27 through 3-32	5-77 through 5-80	9-49, 9-50
3-39, 3-40	6-9, 6-10	9-55, 9-56
4-3, 4-4	7-9, 7-10	10-11 through 10-14
4-7, 4-8	7-19 through 7-22	10-21 through 10-24
5-5, 5-6	8-27, 8-28	

Changes to text and illustrations are indicated by a vertical line at the left of the change; new or extensively revised illustrations are denoted by the symbol ● at the left of the caption.

### Summary of Amendments

- References to Model 8 and Model 12 have been added.
- Miscellaneous additions and corrections.

*Note:* Please file this cover letter at the back of the manual to provide a record of changes.

IBM Corporation, Publications, Department 245, Rochester, Minnesota 55901

© IBM Corp. 1976

Printed in U.S.A.





# Technical Newsletter

This Newsletter No. GN21-5616

Date 30 June 1978

Base Publication No. GC21-7567-2

File No. S3-28

Previous Newsletters GN21-5389

## IBM System/3 RPG II Additional Topics Programmer's Guide

© IBM Corp. 1971, 1974

This technical newsletter applies to the current versions and modifications of the applicable System/3 programs listed in the edition notice and provides replacement pages for the subject publication. These replacement pages remain in effect for subsequent versions and modifications unless specifically altered. Pages to be inserted and/or removed are:

Cover  
Title Page, Edition Notice  
v, vi  
3-11 through 3-16  
4-3, 4-4  
4-27, 4-28  
5-53 through 5-56  
5-56.1 through 5-56.6 (added to accommodate new and moved text)  
5-77, 5-78

Changes to text and illustrations are indicated by a vertical line at the left of the change.

### Summary of Amendments

- Expanded description of the RPG II Linkage Editor, page 5-54
- Included miscellaneous technical changes

*Note:* Please file this cover letter at the back of the manual to provide a record of changes.

IBM Corporation, Publications, Department 245, Rochester, Minnesota 55901

© IBM Corp. 1978

Printed in U.S.A.







# Technical Newsletter

**This Newsletter No.** GN21-5709

**Date** 21 December 1979

**Base Publication No.** GC21-7567-2

**File No.** S3-28

**Previous Newsletters** GN21-5616

GN21-5389

## **IBM System/3 RPG II Additional Topics Programmer's Guide**

© IBM Corp. 1971, 1974

This technical newsletter applies to current versions and modifications of the applicable System/3 programs listed in the edition notice, and provides replacement pages for the subject publication. These replacement pages remain in effect for subsequent versions and modifications unless specifically altered. Pages to be inserted and/or removed are:

v through viii (text rearranged)	6-47, 6-48
3-7, 3-8	7-7 through 7-10
3-17, 3-18	7-19, 7-20
5-65, 5-66	7-31, 7-32
5-75, 5-76	9-49, 9-50
6-33, 6-34	10-41, 10-42
6-37, 6-38	

Changes to text and illustrations are indicated by a vertical line at the left of the change.

### **Summary of Amendments**

Miscellaneous technical changes

*Note:* Please file this cover letter at the back of the manual to provide a record of changes.

**IBM Corporation, Publications, Department 245, Rochester, Minnesota 55901**

© IBM Corp. 1979

Printed in U.S.A.









International Business Machines Corporation  
General Systems Division  
875 Johnson Ferry Road N. E.  
Atlanta, Ga. 30342

IBM World Trade Corporation  
821 United Nations Plaza, New York, New York 10017  
(International)