

**CONTROL DATA[®]
DISK STORAGE UNIT**

MAINTENANCE AIDS

CONTROL DATA
CORPORATION

CUSTOMER ENGINEERING MANUAL

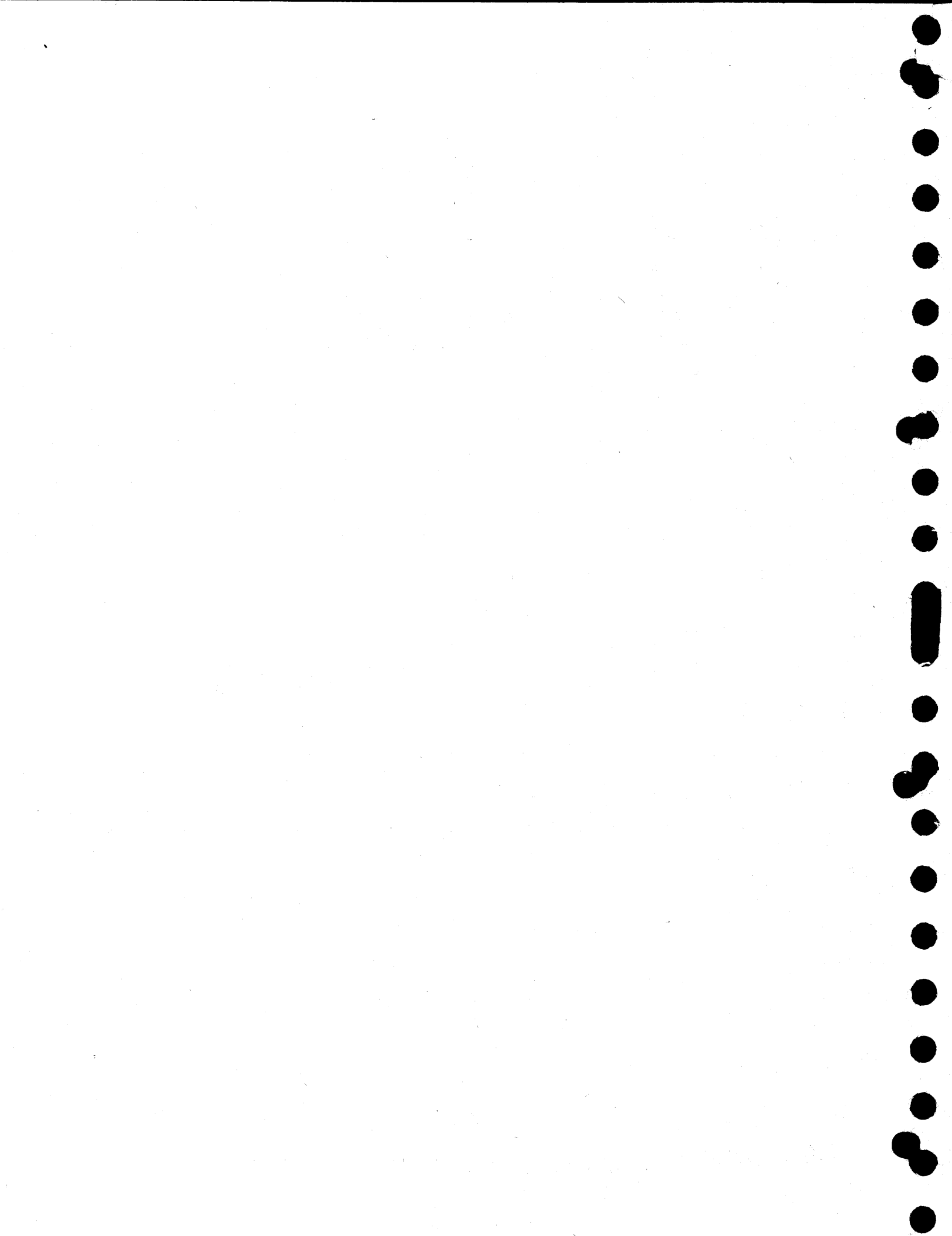

**CONTROL DATA[®]
DISK STORAGE UNIT**

MAINTENANCE AIDS

CONTROL DATA
CORPORATION

CUSTOMER ENGINEERING MANUAL

REVISION RECORD	
REVISION	DESCRIPTION
A (6-10-71)	Manual released.
B (7-27-71)	This revision incorporates Engineering Change Order PE29310 affecting pages vi, vii, viii, 7-72, 7-102 thru 7-174.
C (9-28-71)	This revision incorporates Engineering Change Orders PE29003, PE29048, PE29136, PE29256A, PE29310B, PE29624, PE29641 affecting pages 7-101, 7-108, 7-109, 7-112.1, 7-112.2, 7-146, 7-146.1, 7-156, 7-164, 7-174. Technical Changes affecting pages 7-28.1, 7-28.2, 7-28.3, 7-28.4, 7-53, 7-104.1, 7-104.2, 7-104.3, 7-118.1, 7-118.2, 7-126, 7-126.1, 7-146.2, 7-146.3, 7-146.4, 7-156.1, 7-164.3. Editorial Changes affecting pages v, vi, vii, viii, 7-126.2, 7-146.5, 7-156.1, 7-164.3.
D (11-10-71)	This revision incorporates Engineering Change Orders PE29412, PE29414, PE29481, PE29520, PE29521, PE29567, PE29568, PE29710, PE29712 affecting pages 7-118.1, 7-118.2, 7-130.1, 7-130.2, 7-140, 7-140.1, 7-140.2, 7-146.7, 7-146.8, 7-162, 7-163, 7-168, 7-173, 7-174, 7-178. Technical Changes affecting pages vi, vii, viii, 7-29, 7-110, 7-110.1, 7-125, 7-126, 7-146.5, 7-146.6, 7-158, 7-158.1, 7-164.4, 7-164.5, 7-164.6, 7-171 thru 7-181. Editorial Changes affecting pages 7-110.2, 7-118.3, 7-118.4, 7-140.3, 7-146.9, 7-158.2, 7-162.1, 7-162.2.
E (3-29-72)	This revision incorporates Engineering Change Orders PE29469, PE29483, PE29487, PE29517, PE29517A, PE29546, PE29573, PE29575, PE29775, PE29908, PE30314, PE30379, Technical, and Editorial Changes affecting pages v, vi, vii, viii, 7-27, 7-28, 7-29, 7-40, 7-40.1, 7-40.2, 7-41, 7-62, 7-62.1, 7-62.2, 7-62.3, 7-62.4, 7-102, 7-104.4, 7-104.5, 7-104.6, 7-118.2, 7-130.1, 7-130.2, 7-130.3, 7-130.4, 7-144.1, 7-145, 7-154.1, 7-156.2, 7-158.2, 7-158.3, 7-158.4, 7-164.
F (8-23-72)	This revision incorporates Engineering Change Orders PE31070, PE31106, Technical, and Editorial Changes affecting pages v, vi, vii, viii, ix, 7-32, 7-34, 7-34.1, 7-34.2, 7-60.1, 7-61, 7-68.1, 7-68.2, 7-69, 7-72.1, 7-72.2, 7-90, 7-90.1, 7-90.2, 7-90.3, 7-90.4, 7-90.5, 7-90.6, 7-90.7, 7-90.8, 7-102, 7-103, 7-144.2, 7-145, 7-164.7.
G (11-17-72)	This revision incorporates Engineering Change Order PE31216 affecting pages 7-101, 7-102 and Card Schematic additions affecting pages vi, vii, viii, ix, 7-102.1, 7-102.2, 7-102.3, 7-102.4, 7-104.7, 7-104.8, 7-110.2, 7-110.3, 7-110.4, 7-124.1, 7-124.2, 7-125, 7-146.9 thru 7-146.27, 7-162.2,
H (12-13-72)	This revision incorporates Engineering Change Order PE31271 affecting pages vii, 7-146.10, 7-146.11, 7-146.12, and Editorial Changes affecting page 7-164.7/7-164.8.
J (2-22-73)	This revision incorporates Engineering Change Orders PE31319 and PE31330 affecting pages vi, vii, 7-146.10 thru 7-146.18.
K (5-7-73)	This revision incorporates Engineering Change Orders PE31376, PE31380, PE31387 affecting pages vii, 7-121, 7-124, 7-125, 7-146.12, 7-146.27, 7-146.28, 7-146.29, 7-146.30, 7-146.31.
L (8-9-73)	This revision incorporates IWHV diagram affecting pages vii, 7-164.7; 7-164.8.
Publication No. 70616800	

Address comments concerning this manual to:

Control Data Corporation
 Technical Publications Department
 7801 Computer Avenue
 Minneapolis, MN 55435

or use Comment Sheet in the back of this manual.

© 1971, 1972, 1973
 by Control Data Corporation
 Printed in the United States of America

PREFACE

Customer engineering material for the CONTROL DATA® Disk Storage Unit is contained in four separate manuals, which provide all information needed to install, operate, and maintain the unit:

General Description, Operation,
Installation and Checkout, Theory of
Operation, Maintenance

Diagrams, Wire Lists

Illustrated Parts List

Maintenance Aids



CONTENTS

7. MAINTENANCE AIDS			
General	7-1	Lamp Driver - ICB	7-29
Logic	7-1	Write Driver - JAB	7-30
Physical Description	7-1	Write Driver - JAD	7-32
Pin Assignments	7-1	Write Driver - JAH	7-34.1
Test Points	7-3	Erase Driver - JBB	7-34.1
Use of Relative Level Indicators	7-3	Line Transmitter - LCA	7-35
Information Contained within		Line Transmitter - LCB	7-37
Logic Symbols	7-4	Oscillator - MAC	7-38
Discrete Component Circuits	7-4	Oscillator - MAD	7-40
Integrated Circuits	7-6	Ringing Amplifier - MBC	7-41
Wired Functions	7-6	Quantizing Detector - QCA	7-41
Standard/Non-Standard Logic		Quantizing Detector - QFB	7-50
Level Indicator	7-8	Single Shot - QFF	7-50
Discrete Component Circuit		Function Generator - QCD	7-53
Descriptions	7-8	Line Receiver - RAB	7-55
Gated Amplifier - FAB	7-9	Switch Receiver - RCB	7-58
Current Amplifier - FAD	7-9	Line Receiver - RFA	7-60
Gated Intermediate Level		Receiver Terminator and	
Amplifier - GJA	7-11	Offset - RFB	7-61
Gated Analog Clamp - GJB	7-12	Single Shot - RHB	7-62
Multiple Gate Analog		Bipolar Current Buffer - SAA	7-62.1
Clamp - GJC	7-14	Amplifier - SAB	7-62.1
Gated Analog Clamp - GJD	7-14	Fwd EOT Clamp - SAC	7-62.1
Level Translator - GKA and		Demodulator - SBA	7-64
Digital to Analog Converter -		Attenuator - SBB/SBD	7-65
GKB	7-16	Voltage Divider - SBE/SBF	7-65
Level Translator - GKC	7-18	Filter - SCA	7-68
High Level Amplifier - HAA	7-18	Filter - SCB	7-68.1
High Level Amplifier - HAB	7-19	Multiple Head Select Detector -	
High Level Amplifier - HJA	7-22	SCF	7-69
Analog Power Amplifier - HJB	7-22	Delay - UB	7-70
Differential Amplifier - HJC	7-25	Unidirectional Time Delay -	
Amplifier/Level		UEA	7-71
Translator - HJD	7-25	Delay - UEB	7-72
Level Translator - HJE	7-27	Delay - UF	7-72.2
Differential Amplifier - HJF	7-28.1	And - VAB	7-73
Differential Amplifier - HJG	7-28.1	And/Or (Single Input) - VAC,	
Differential Amplifier - HJH	7-28.1	VJW	7-75

Power Driver - VJK	7-76	2FQN Analog Gate and Amplifier	7-110.2
Power Driver - VJL	7-76	9FQN Analog Gate and Amplifier	7-110.4
And - VJM	7-79	0BCV Select/Reset	7-112
Or - VJN	7-80	1BWV Fault Detection	7-113
And - VJP	7-81		
Power Driver - VJR	7-82	0BXV Ready/On Line/Pack Change/Busy/Gated Attn	7-115
Or - VJS	7-82	0CAV Voltage Checking	7-117
Or - VJT	7-83	0CBV Seek Complete	7-118
And - VJU, VJV	7-84	1CFV/ACFV E. O. T. Threshold Detector	7-118.1
And/Or - VJW	7-84	0CGV/ACGV Voltage Generator Track Servo	7-118.3
Inverter - VKF	7-85	0CPV Read Recovery	7-119
Or Gate - VKG	7-86	ACPV Read Recovery	7-122
Current Detector - VKH	7-87	2CPV Read Recovery	7-124.1
And Gate - VKJ	7-88	1CQV Mumper	7-126
Solenoid Driver - VKK	7-89	0CSV D/A Converter	7-127
Level Translator - VKP	7-90	0CTV Vel and Desired Vel Function	7-129
DC Current Detector - VKR	7-90.2	1CTV/ACTV Vel and Desired Vel Function	7-130.1
Gated Level Translator - VKS	7-90.3	BCTV Vel and Desired Vel Function	7-130.3
Erase Cutoff Detector - VKT	7-90.4	0CUV Coarse-Fine, Sum Amp and On Cylinder	7-131
Write Shutoff Detector - VKU	7-90.5	BCUV Coarse-Fine, Sum Amp and on Cylinder	7-132.1
AC Write Current Detector - VKV	7-90.6	0CVV Power Ampl Preamp	7-133
Level Translator - VKW	7-90.7	BCWV Access Control	7-134
Flip-Flop - WBB	7-90.8	CCWV Access Control	7-137
Toggle Flip-Flop - WBC	7-92	DCWV Access Control	7-140
Single Shot - XAA	7-93	0CXV Demod and Zero Cross Det	7-140.3
Single Shot - XAB	7-93	0CYV Head Decoder	7-143
Gated Single Shot - XAC	7-96	0CZV Off-Even-Slope, Analog Switch	7-144.1
Single Shot - XAE	7-96	1EEV Unit Reserve	7-144.2
Card Diagrams	7-101	1EFV Channel Steering	7-145
Preamp Position Xducer	7-101	AEWV Hold and Disconnect	7-146
2AFN Head Select, Preamp	7-102.1	1EYV Output Control	7-146.2
0AFN Head Select, Preamp	7-102.4		
0AWV Track Servo Fine Position	7-104.1		
1AYN Write Erase Circuits	7-104.4		
2AYN Write Erase Circuits	7-104.7		
0AYN Write Erase Circuits	7-105		
EAYN Write Erase Circuits	7-108		
FAYN Write Erase Circuits	7-110		

0FZN Track Servo Preamp	7-146.2	0WCV Nine Bit Comparator	7-160
1FZN Track Servo Preamp	7-146.7	0WDV Fault Register	7-161
2JAV -3V Regulator/Fault Detector	7-146.9	1WDV Fault Register	7-162
3JTV Read and Write Recovery	7-146.27	1WEV R/W/E Enable and Fault Detect	7-162.1
3JUV Tag and Bus Control	7-146.29	CWEV R/W/E Enable and Fault Detect	7-162.2
3JVV Write Blot Simulation, Write Blot Conversion	7-146.10	DWEV R/W/E Enable and Fault Detect	7-163
3JWV Busy Reserved	7-146.13	EWEV R/W/E Enable and Fault Detect	7-164
3JXV Head Buffer	7-146.16	0WGV Unit Reserve	7-164.1
2JYV Difference Adder	7-146.19	2WGV Unit Reserve	7-164.7
2JZV Direct Access Card	7-146.23	1WHV Latency	7-164.8
0PAV Lamp Driver	7-146.31	0WJV Sector/Index Separator	7-164.2
0RDV Diff Line Receiver	7-148	0WLTV Latch/Gates/Delay	7-164.3
0REV Terminator	7-149	1WXV Pack Change, Seek Complete, Hi/Lo, Busy, Unit Spare	7-164.4
0RFV Receiver	7-150	0WYV Counter Control	7-165
0SAV Switch Receiver	7-151	1WZV Difference Counter, Odd/Even and Slope	7-166.1
0SBV Photo Sector Sensor	7-152.1	0WZV Difference Counter, Odd/Even and Slope	7-167
1TDV Line Transmitter	7-153	Head and Disk Pack Replacement Criteria	7-169
0TFV "A" Xmtr	7-154	Head Replacement Criteria	7-169
1TGV L-Xmtr/Rcvr and +3 Volt Monitor	7-154.1	Disk Pack Replacement Criteria	7-169
0TGV L-Xmtr/Rcvr and +3 Volt Monitor	7-155	Disk Pack Runout Check	7-170
1UAV Speed Detector	7-156	Access Tester Card	7-172
0UDV Speed Detector	7-156.1	Read/Write Tester Card	7-177
1UDV Speed Detector	7-156.2		
0VAV Osc and Sector Demodulator	7-158		
AVYV 50 kHz Osc and Analog Switch	7-158.2		
OVZV 50 kHz Xtal Osc and Pwr Ampl	7-158.4		
0WAV/1WAV Ten Bit Counter	7-159		

FIGURES

7-1	Logic Card Detail	7-2	7-30	Quantizing Detector - QCA	7-43
7-2	Inversion Conventions	7-4	7-31	Speed Detector - QDB	7-45
7-3	Discrete Component Circuit	7-5	7-32	Voltage Checker - QEB	7-47
7-4	Integrated Circuit	7-7	7-33	Quantizing Detector - QFA	7-49
7-5	Wired Functions	7-8	7-34	Quantizing Detector - QFB	7-51
7-6	Gated Amplifier - FAB	7-10	7-35	Single Shot - QFF	7-52
7-7	Current Amplifier - FAD	7-11	7-36	Function Generator - QGD	7-54
7-8	Gated Intermediate Level Amplifier - GJA	7-12	7-37	Line Receiver - RAB	7-57
7-9	Gated Analog Clamp - GJB	7-13	7-38	Switch Receiver - RCB	7-59
7-10	Multiple Gate Analog Clamp - GJC	7-15	7-39	Line Receiver - RFA	7-60. 1
7-11	Gated Analog Clamp - GJD	7-16	7-39.1	Receiver Terminator and Offset - RFB	7-61
7-12	Level Translator and D/A Converter - GKA/GKB	7-17	7-39.2	Delay - RHB	7-62
7-13	Level Translator - GKC	7-19	7-40	Bipolar Current Buffer - SAA	7-63
7-14	High Level Amplifier - HAA	7-20	7-40.1	Amplifier - SAB	7-62. 2
7-15	High Level Amplifier - HAB	7-21	7-40.2	Fwd EOT Clamp - SAC	7-62. 3
7-16	High Level Amplifier - HJA	7-23	7-41	Demodulator - SBA	7-64
7-17	Analog Power Amplifier - HJB	7-24	7-42	Attenuator - SBB/SBD	7-66
7-18	Differential Amplifier - HJC	7-26	7-43	Voltage Divider - SBE/SBF	7-67
7-19	Amplifier/Travel Translator - HJD	7-27	7-44	Filter - SCA	7-68
7-20	Level Translator - HJE	7-28	7-45	Filter - SCB	7-68. 1
7-20.1	Differential Amplifier - HJF	7-28. 2	7-45.1	Multiple Head Select Detector - SCF	7-68. 2
7-20.2	Differential Amplifier - HJG	7-28. 3	7-46	Delay - UB	7-70
7-20.3	Differential Amplifier - HJH	7-28. 4	7-47	Unidirectional Time Delay-UEA	7-71
7-21	Lamp Driver - ICB	7-29	7-48	Delay - UEB	7-72
7-22	Write Driver - JAB	7-31	7-48. 1	Delay - UF	7-72. 1
7-23	Write Driver - JAD	7-33	7-49	And - VAB	7-74
7-23.1	Write Driver - JAH	7-34	7-50	And/Or (Single Input) - VAC, VJW	7-75
7-24	Erase Driver - JBB	7-34. 2	7-51	Power Driver - VJK, VJS	7-77
7-25	Line Transmitter - LCA	7-36	7-52	Power Driver - VJL	7-78
7-26	Line Transmitter - LCB	7-37	7-53	And - VJM	7-79
7-27	Oscillator - MAC	7-39	7-54	Or - VJN	7-80
7-28	Oscillator - MAD	7-40. 1	7-55	And - VJP	7-81
7-28.1	Oscillator - MAG	7-40. 2	7-56	Power Driver - VJR	7-82
7-29	Ringing Amplifier - MBC	7-42	7-57	Or - VJT	7-83

7-58	And - VJU, VJV	7-84	7-63.7	Level Translator - VKW	7-90.7
7-59	Inverter - VKF	7-85	7-64	Flip-Flop - WBB	7-91
7-60	Or - VKG	7-86	7-65	Toggle Flip-Flop - WBC	7-92
7-61	Current Detector - VKH	7-87	7-66	Single Shot - XAA	7-94
7-62	And - VKJ	7-88	7-67	Single Shot - XAB	7-95
7-63	Solenoid Driver - VKK	7-89	7-68	Gated Single Shot - XAC	7-97
7-63.1	Level Translator	7-90	7-69	Single Shot - XAE	7-98
7-63.2	DC Current Detector - VKR	7-90.1	7-70	Disk Pack Runout Check	7-170
7-63.3	Gated Level Translator - VKS	7-90.3	7-71	Access Tester Card	7-173
7-63.4	Erase Cutoff Detector - VKT	7-90-4	7-72	Repeat Mode Timing	7-175
7-63.5	Write Shutoff Detector - VKU	7-90.5	7-73	Read/Write Tester Card	7-178
7-63.6	AC Write Current Detector - VKV	7-90.6	7-74	Write Operation Timing All Zeros	7-179

TABLE

7-1	CDC Element Number Cross Reference	7-7
-----	---------------------------------------	-----



Information for these sections is included in Disk Storage Unit. General Description, Operation, Installation and Checkout, Theory of Operation, Maintenance Manual.

SECTION 1

GENERAL DESCRIPTION

SECTION 2

OPERATION

SECTION 3

INSTALLATION AND CHECKOUT

SECTION 4

THEORY OF OPERATION



SECTION 5

DIAGRAMS

Information for this section is contained in Disk Storage Unit Diagrams, Wire Lists Manual.

SECTION 6

MAINTENANCE

Information for these sections is included in Disk Storage Unit General Description, Operation, Installation and Checkout, Theory of Operation, Maintenance Manual.



SECTION 7

MAINTENANCE AIDS



PART 1

DISCRETE COMPONENT
CIRCUIT DESCRIPTIONS



MAINTENANCE AIDS

GENERAL

Section 7 contains information on logic circuits, the criteria used in determining the further usability of read/write heads and disk packs, and the tester card used in the Maintenance section.

LOGIC

The logic used in this device consists of two styles of circuits: discrete component and integrated circuits. Discrete component circuits contain individually identifiable resistors, capacitors, transistors, etc.

PHYSICAL DESCRIPTION

All components of the logic cards (Figure 7-1) are mounted on one side of a printed circuit board (PCB). Two sizes of PCB are used. The 6.075 x 2.3 inch PCB is the basis for the half-size card (plugs into one logic row). The 6.075 x 4.85 inch PCB is used on the full-size card. The latter card spans two rows of the logic chassis. The female connector of the cards mate with wire wrap pins extending through the chassis wire wrap board. The logic cards functions are dispersed from the reverse ends of these pins through wiring installed using the wire wrap technique. Cards installed in the logic chassis are restricted from vertical and horizontal movement by card guide spacers.

Numerical designators (1 through 99) are etched on the non-component side of the board identify each transistor. A 4-character alpha-numeric designator is etched on the non-component side of the board to identify the card type. A matrix code (alphanumeric) also appears on this side. Non-amplifying components such as integrated circuits, resistors, capacitors, diodes, etc., are not marked.

Pin Assignments

Half-size cards are equipped with a 28-pin (sockets) connector, while the full-size card contains a 62-pin connector. Connectors are mounted along the shorter dimension on the component side of the board.

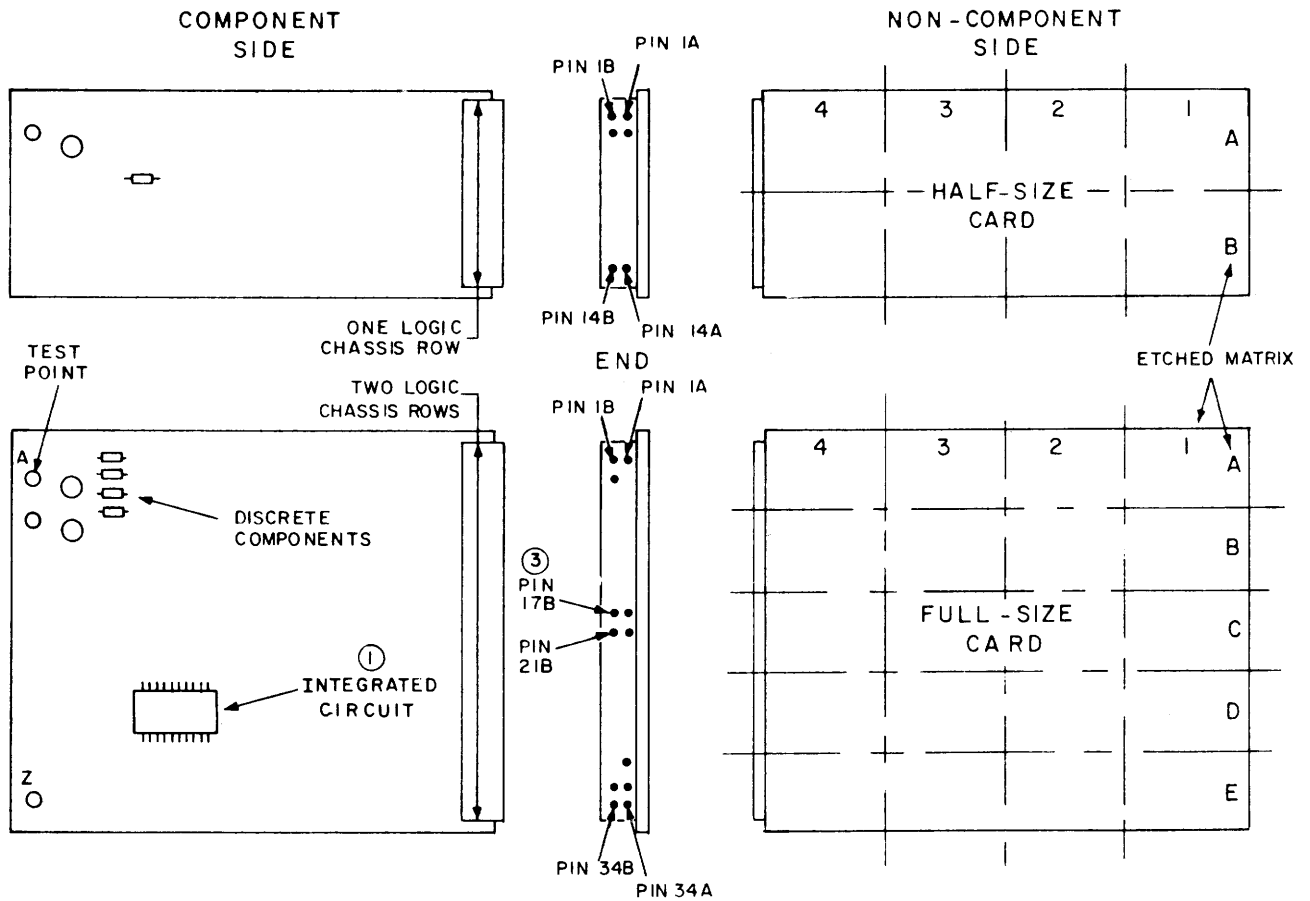

NOTES:

- ① INTEGRATED CIRCUIT LOCATED AT BOARD MATRIX D2
2. ON LOGIC DRAWINGS, CARD PINS AND MATRIX LOCATIONS, ARE PRECEDED BY 3 DIGITS THAT IDENTIFY LOCATION OF CARD IN LOGIC CHASSIS (A23, POSITION 23 IN CHASSIS ROW A)
- ③ PINS 18, 19, 20, (A AND B) NOT PRESENT.

6 T 6

Figure 7-1. Logic Card Detail

The pins of each card connector are arranged in two columns (A and B) and are numbered from the top starting with pin 1 and continuing through pin 14 on the half-size card. The pins of the full-size card are numbered 1 through 34, however pins 18A, 18B, 19A, 19B, 20A, and 20B are omitted.

The logic chassis wire wrap surface (side opposite surface where cards are installed) contains wire wrap pin identification information adjacent to each chassis row. Wire wrap pins are numbered 1 through 17 in each chassis row. When a full-size card (spans two logic rows) is installed in the logic chassis, card connector pins (sockets) 1A and 1B mate with wire wrap pins 1A and 1B of the upper row, while card connector pins 21A and 21B mate with wire wrap pins 1A and 1B of the row immediately below. The logic diagrams for this unit show connections in terms of wire wrap pins.

Test Points

Test points are located near the edge of the card opposite the connector and in other strategic places on the component side of the board. Test points are identified alphanumerically starting with A on the top, outer edge. In most cases, test points A and Z are available for ground reference.

USE OF RELATIVE LEVEL INDICATORS

The relative level indicator is a small circle located at the origin or termination of a signal line, and tangent to a logic symbol. The presence or absence of this indicator tells the conditions that are necessary to satisfy the function of the logic symbol. The presence of the circle indicates a 0 logic level on that line is needed to satisfy the function. The absence of the circle represents a logical 1 as needed to satisfy the function.

The relative level indicator depicts the occurrence of inversion. Figure 7-2 shows some representative examples of the relative level indicator being used in this manner.

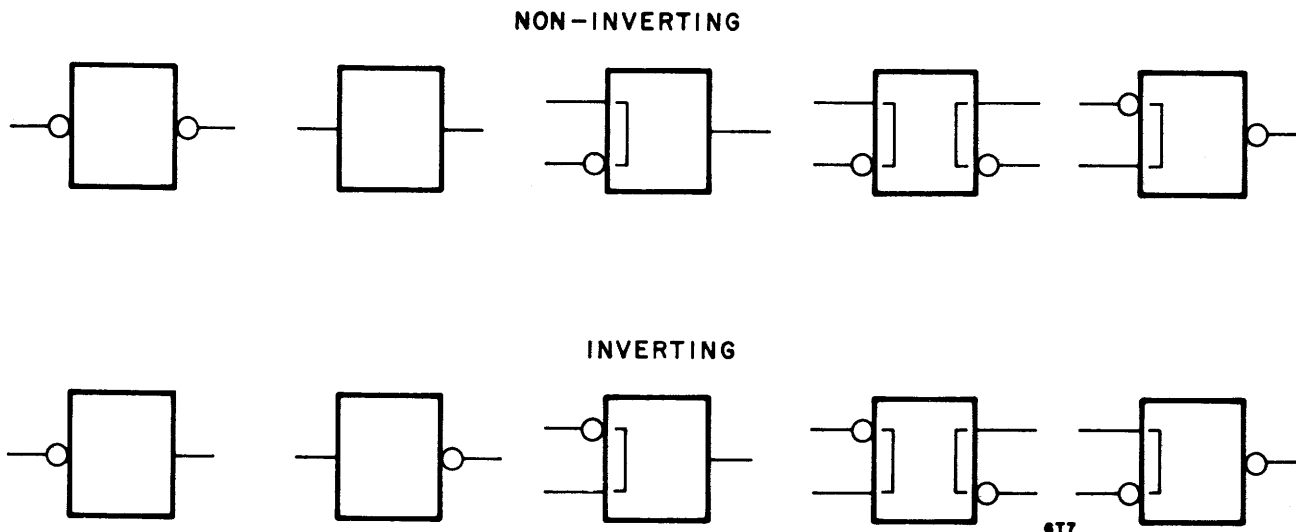

Figure 7-2. Inversion Conventions

INFORMATION CONTAINED WITHIN LOGIC SYMBOLS

Discrete Component Circuits

Figure 7-3 shows a schematic (as shown on card schematic diagram) and the logical representation (as shown on logic diagrams) for the same theoretical discrete component circuit. Four lines of information are contained within the logic symbol. The top line is the function symbol and designates the board logic function of that particular symbol. In this case, \triangleright represents an amplifier, the logic function performed by the circuit. The third line, also an alphabetic code, designates the circuit type being used (HAB). The circuit type is a subdivision of the function identifier (specifically a high level amplifier). By using the circuit type designator, detailed information on that particular circuit can be derived in the following paragraphs (see Discrete Component Circuit Descriptions).

The second line within the symbol is used to differentiate that particular symbol from similar symbols that appear on the logic diagram. It is called the logic term and consists of a one-letter prefix and an assigned identification number (in this case, A705).

The numbers on the input lines to the symbol indicate which transistor is driven by that input line. For example, the upper input has a number 22 on its line, showing that it drives transistor number 22 (ie., Q22 on the card schematic diagram).

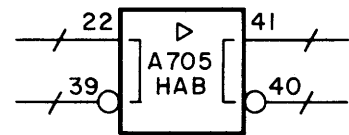
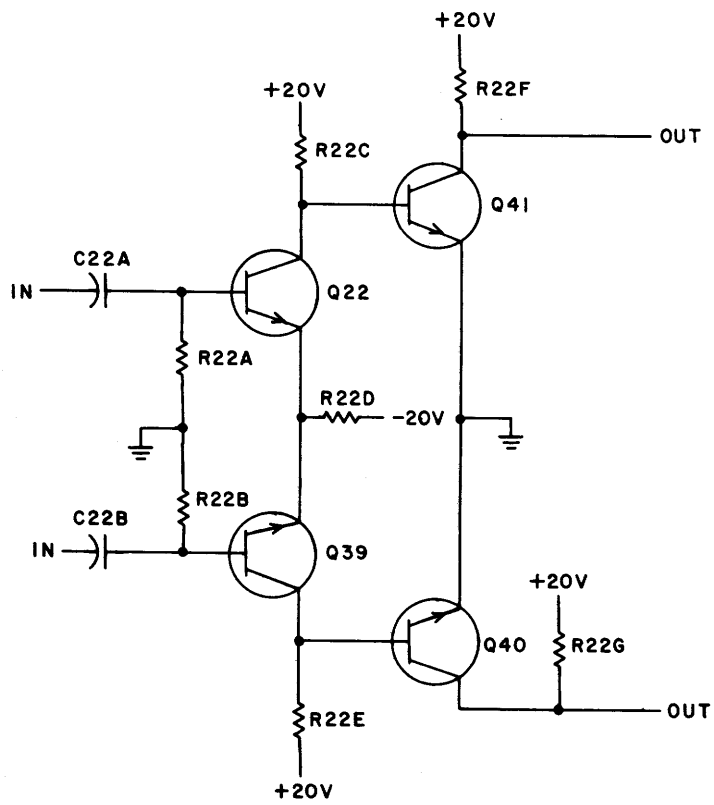

678

Figure 7-3. Discrete Component Circuit

The output lines also have numbers associated with them. These numbers indicate which transistor directly feeds the output line. For example, the lower output line has a number 40 above it, indicating that the output from transistor number 40 (Q40 on the card schematic diagram) drives the lower output line.

The lines on the interior of the logic block that bracket both inputs and both outputs show that the input lines and the output lines are differentials. The relative level indicators show that the amplifier does not invert the signal. Slashes on the inputs and outputs show that the signal levels are non-standard.

Integrated Circuits

Figure 7-4 shows the schematic version (as shown on card schematic diagram) and the logical representation (as shown on logic diagrams) for the same representative integrated circuit.

The most apparent difference occurs in the outline shapes for the circuit. The logic drawings use a four sided block to depict all logic circuits. Two lines of information appear in the logic version that do not appear on the schematic block. They are the function symbol which identifies the block as an OR gate and the logic term which provides specific identification for the circuit. Points of similarity include the package pin numbers and the Control Data element number. Refer to Table 7-1 for manufacturers information of the various element numbers.

The last item of information regarding these two representations involves the location code which borrows part of the schematic symbols reference designator. In the reference designator (U-A4B), the U specifies a non-amplifying integrated circuit, the A4 is the circuits board matrix location for the package, and the B indicates the section of the package. (A 140 package is a four section package. Each section is a separate circuit. Sections are identified A through D.) The location code (on logic drawings) borrows the matrix location and additionally specifies the location of the card in the logic chassis: position 5 of row B.

WIRED FUNCTIONS

The logical representation for wired functions is shown in Figure 7-5. These functions are used where circuits have the capability of being combined as an AND or an OR function by having the outputs connected. This is simply a physical connection and no electrical or electronic components are involved. The logical interpretation of a wired OR function simply requires that one of the inputs be a logic 0 before the output can be a logic 0. The wired AND output will be a logic 1 only when both inputs are logic 1's.

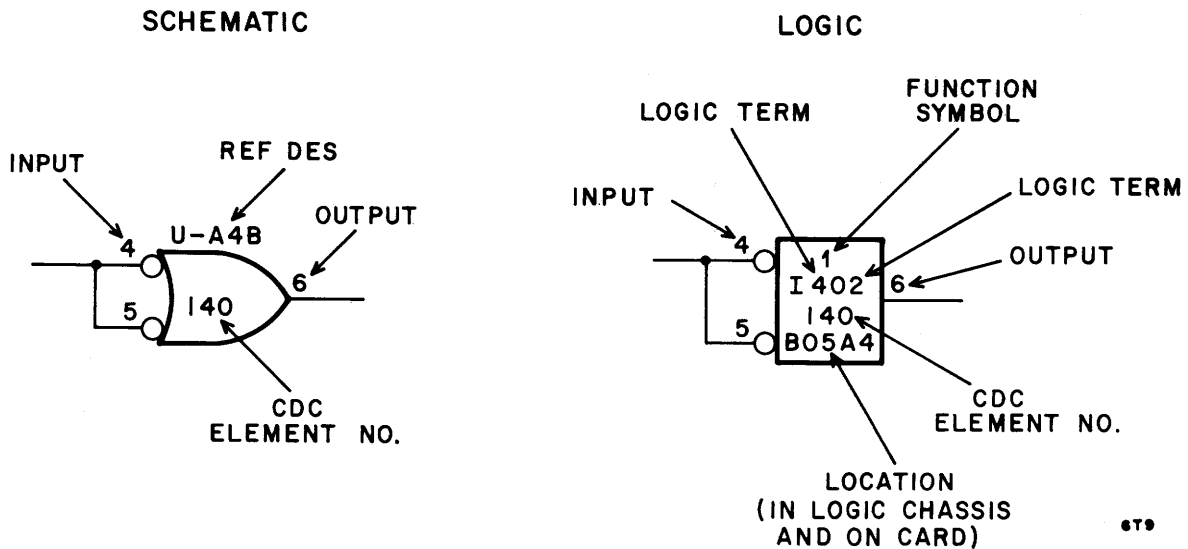

Figure 7-4. Integrated Circuit

TABLE 7-1. CDC ELEMENT NUMBER CROSS REFERENCE

CDC Element No.	Manufacturer, Type	Description
140	Fairchild, 9002	Quad, 2-input NAND
141	Fairchild, 9003	Triple, 3-input NAND
143	Fairchild, 9009	Dual, 4-input buffer
145	Fairchild, 9005	Dual, AND/OR inverter
146	Fairchild, 9016	Hex, inverter
147	Fairchild, 9007	8-input NAND
149H	Motorola, 3021	2-input exclusive OR
161	Fairchild, 9601	Retriggerable multivibrator
162	Texas Instrument, 75107	Dual differential receiver
163	Signetics, 8281	4-bit presettable counter
172H	Motorola, 3002	Quad, 2-input NOR
173H	Motorola, 3004	Quad, 2-input NAND
175	Motorola, 3060	Dual type-D flip-flop
182	Signetics, 8291 or Texas Instrument, 74197	4-bit presettable counter
191	Fairchild, 9301	1 of 10 decoder
200	Texas Instrument, 7406	Hex, inverter
300	Fairchild, 709	Operational amplifier
301	Fairchild, 741	Operational amplifier
304	Fairchild, 715	Operational amplifier



6T10

Figure 7-5. Wired Functions

STANDARD/NON-STANDARD LOGIC LEVEL INDICATOR

The input to a logic function at a voltage other than the standard logic level is represented by a slash across the non-standard level line. Absence of the slash (or absence of an X, see below) indicates a standard logic level on that line.

When the input signal to a logic function is an analog signal, the input line will have an X across it. The analog designator is used on lines that normally operate at more than two voltage levels.

INTEGRATED CIRCUIT DESCRIPTIONS

Basic functional information for integrated circuits is provided on the Key to Logic Symbols sheet of the logic diagrams.

Detailed functional descriptions and schematic diagrams for integrated circuits is available in the circuit manufacturers handbook, Table 7-1.

DISCRETE COMPONENT CIRCUIT DESCRIPTIONS

Figures 7-6 through 7-69 are the schematic diagrams for the discrete component circuits used in this device. A verbal description supports each circuit diagram. The order of presentation is in accordance with the 3-letter alphabetical circuit type designator.

Gated Amplifier - FAB

The FAB circuit (Figure 7-6) is a low level amplifier that amplifies the analog read signal from the head. Input B is a gate input.

When input B is +20v, diodes CRNA, CRNB, CRNC, CRND, CRNE and CRNF are forward biased. The voltage between CRNC and CRNE and between CRND and CRNF is clamped at approximately +2.0v. With all diodes forward biased, the read signal can pass to the amplifier.

When input B is ground, diodes CRNG and CRNH clamp the voltage at +0.6v. This reverse biases the input diodes. No read signal can enter.

The preamplifier is a three stage amplifier using an emitter follower output stage for low output impedance. The integrated preamplifier has discrete component ac and dc feedback.

AC feedback is provided by CNE and RNH in the top half and CNF and RNJ in the lower half of the circuit. The signal is brought back to the emitters of the input stage to increase input impedance.

DC feedback is provided by RNG, RNE and CNC (to ground) in the upper half and RNK, RNF and CND (to ground) in the lower half of the circuit. This feedback helps to stabilize the output.

Capacitors CNG, CNH and CNJ, and CNK filter noise from the +20v and -20v power supplies, respectively. The electrolytic capacitors filter low frequency noise. The paper capacitors filter high frequency noise.

Open loop gain in the amplifier is approximately 180. Closed loop gain in the amplifier is approximately 30.

Current Amplifier - FAD

The FAD circuit (Figure 7-7) provides a voltage drop from A to C of either 0.5 or 5.0 volts which is selected with a "1" or a "0", respectively, at B. A "1" at B turns transistor QNA on. This provides base drive through RNC to QNB which turns on. The output at C is now the same as the input at A except for the emitter-collector drop (0.5v) across QNB. With input B at ground, "0", QNA is off and base drive to QNB is provided through the 4.7-volt Zener diode, CRNC. The voltage drop from A to C is V_{be} plus V_z . Resistor RND improves circuit operation by increasing the Zener current.

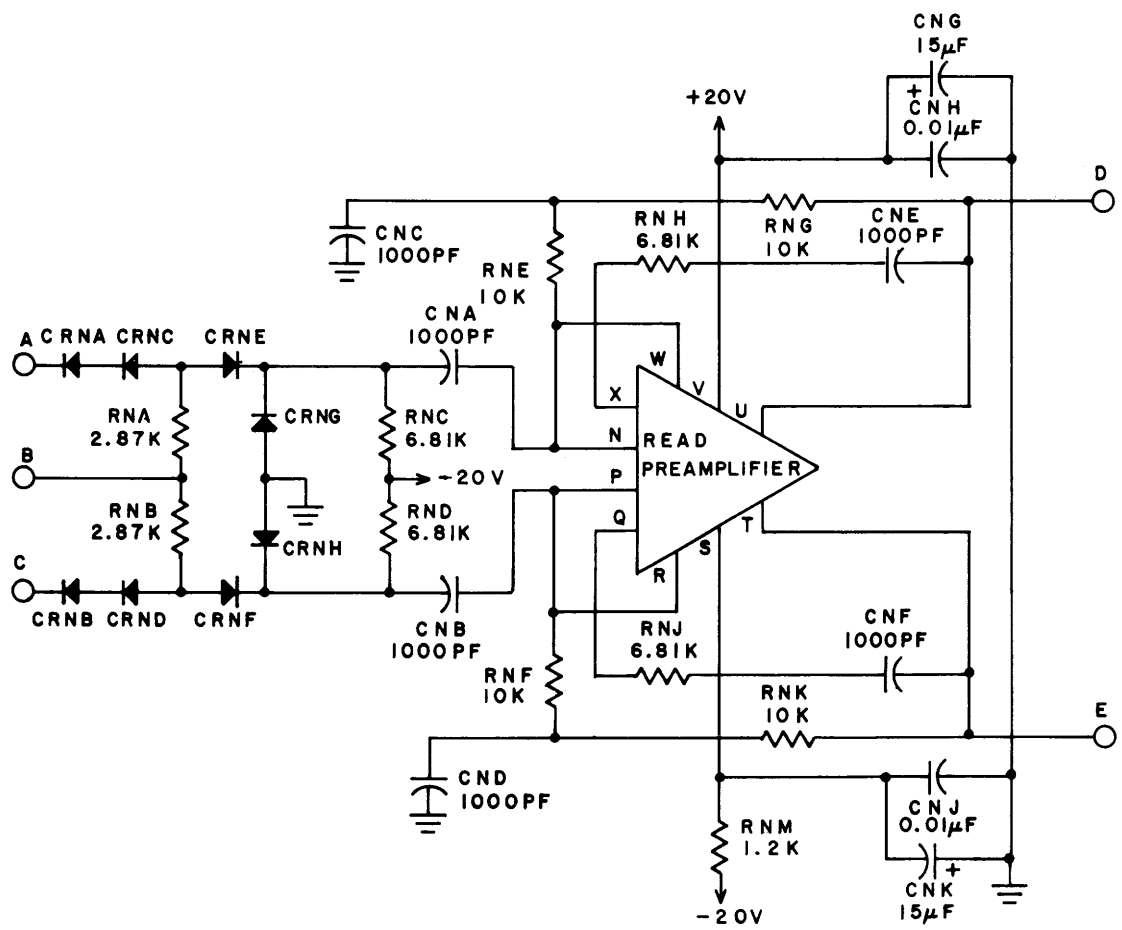
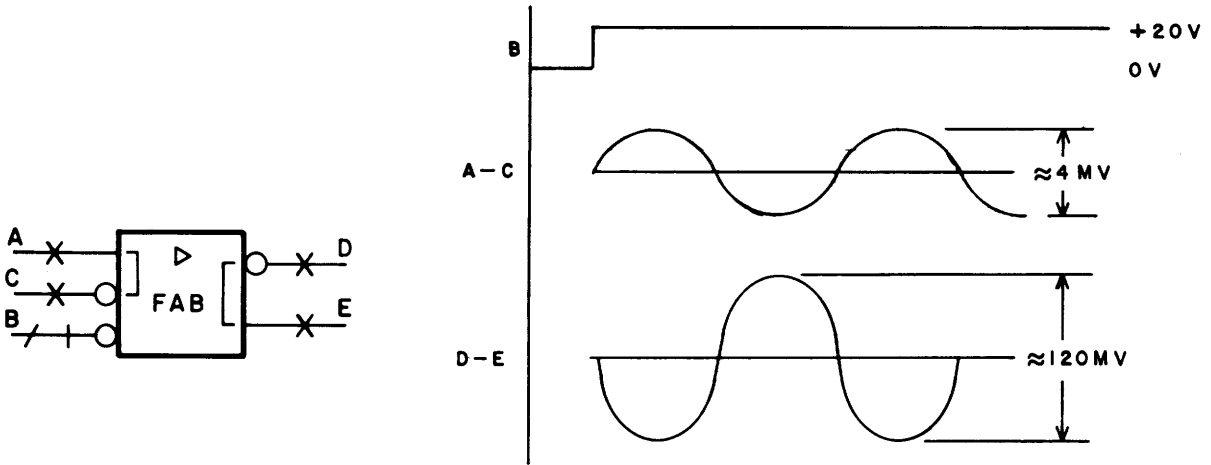

NOTE: VOLTAGE AND COMPONENT VALUES ARE FOR REFERENCE ONLY.

6T100

Figure 7-6. Gated Amplifier - FAB

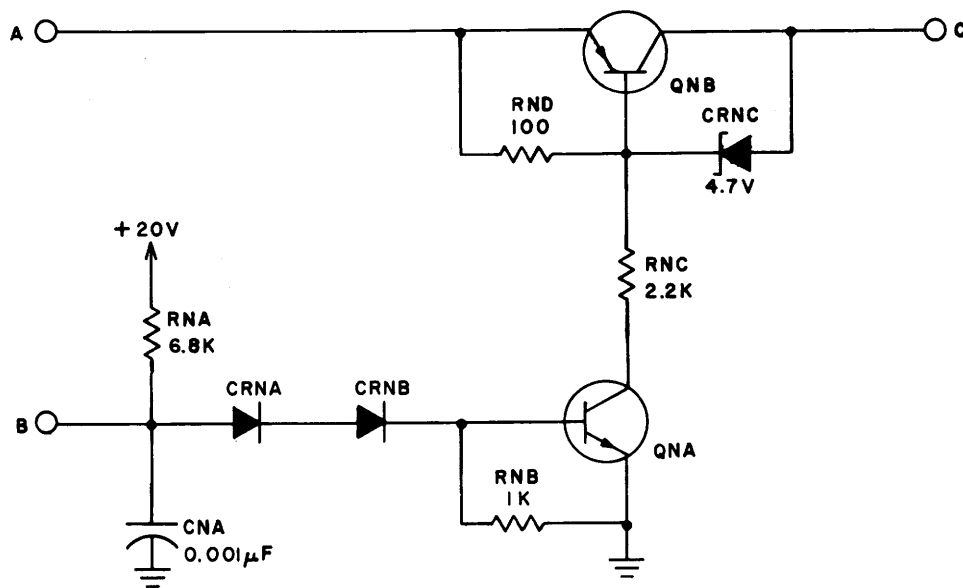
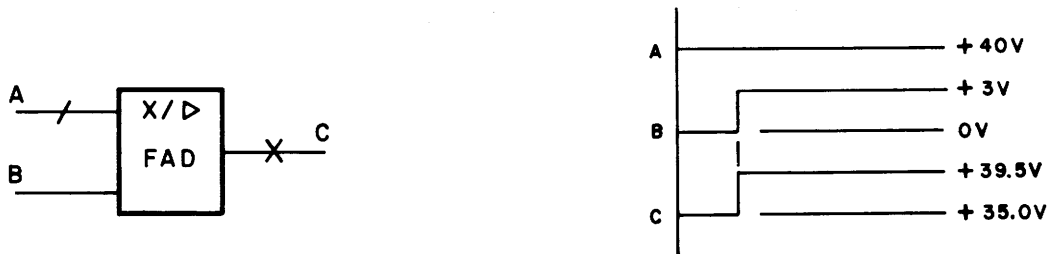

6T101

NOTE: VOLTAGE AND COMPONENT VALUES ARE FOR REFERENCE ONLY.

Figure 7-7. Current Amplifier - FAD

Gated Intermediate Level Amplifier - GJA

The GJA circuit (Figure 7-8) is an analog gate that is controlled by input B. When input B is +20v, both transistors are on. All analog signals pass through the circuit. Capacitors CNA and CNB ensure that only analog signals are passed. CNC filters noise spikes from the gating signal. Dc power for the transistors is supplied by the circuit in the next stage.

When input B is +0.2v, both transistors are off. No signals pass through the circuit.

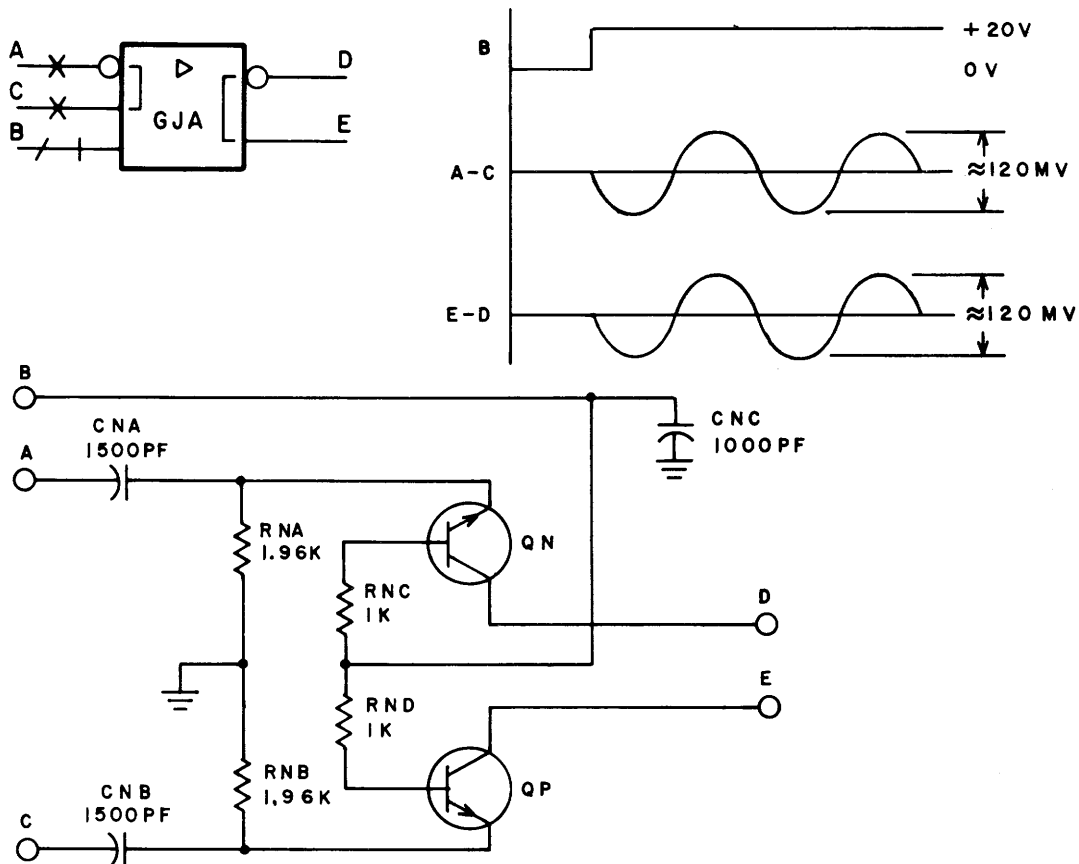

NOTE: VOLTAGE AND COMPONENT VALUES ARE FOR REFERENCE ONLY.

6T102

Figure 7-8. Gated Intermediate Level Amplifier - GJA

Gated Analog Clamp - GJB

The GJB circuit (Figure 7-9) functions to turn QR (an N channel junction field effect transistor) on when a logical 0 is applied at input B and to turn QR off when a logical 1 is applied at input B.

In actual application output C is connected to the summing point of an operational amplifier and therefore is always at ground potential. Terminal A is connected to the output of the operational amplifier. When QR turns on, it presents a very low resistance feedback path to the operational amplifier thus forcing the gain of the amplifier toward zero. As a result the operational amplifier is essentially clamped to an output voltage of zero.

The on-off resistances of QR are 40 ohms and 50 megohms respectively.

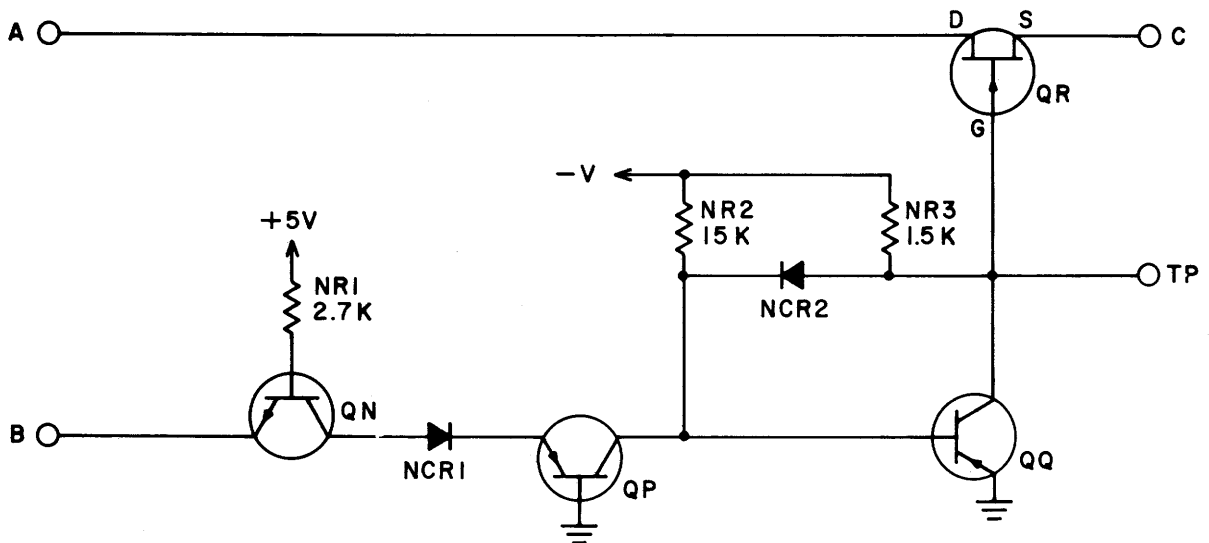
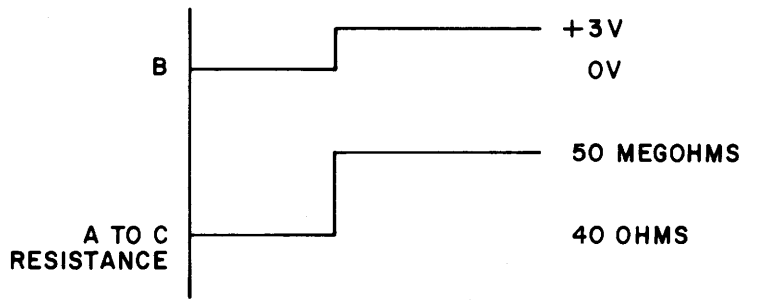
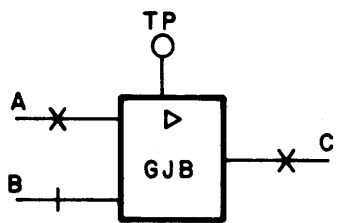

NOTE: VOLTAGE AND COMPONENT VALUES ARE FOR REFERENCE ONLY.

6T132

Figure 7-9. Gated Analog Clamp - GJB

Multiple Gate Analog Clamp - GJC

The GJC circuit (Figure 7-10) functions to turn QQ (an N channel junction field effect transistor) on when a logical 0 is applied at any of the B inputs and to turn QQ off when all of the B inputs are at a logical 1.

In actual application output C is connected to the summing point of an operational amplifier and therefore is always at ground potential. Terminal A is connected to the output of the operation amplifier. When QQ turns on, it presents a very low resistance feedback path to the operational amplifier thus forcing the gain of the amplifier toward zero. As a result the operational amplifier is essentially clamped to an output voltage of zero.

The on-off resistances of QQ are 40 ohms and 50 megohms respectively.

Gated Analog Clamp - GJD

The GJD circuit (Figure 7-11) functions to turn QP (an N channel junction field effect transistor) on when a logical 0 is applied at input B and to turn QP off when a logical 1 is applied at input B.

In actual application output C is connected to the summing point of an operational amplifier and therefore is always at ground potential. Terminal A is connected to the output of the operational amplifier. When QP turns on, it presents a very low resistance feedback path to the operational amplifier thus forcing the gain of the amplifier toward zero. As a result, the operational amplifier is essentially clamped to an output voltage of zero.

A series resistor is normally connected between the input analog voltage and point A. The on-off resistances of QP are 40 ohms and 50 megohms respectively.

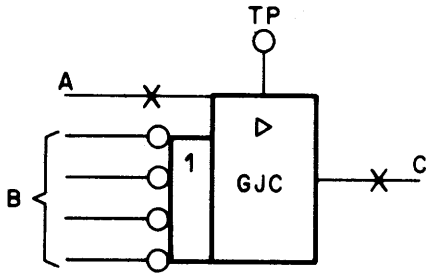

IF ANY INPUT B EQUALS 0 VOLTS,
THE A TO C RESISTANCE EQUALS 40 OHMS.

IF ALL INPUT B'S EQUAL +3 VOLTS,
THE A TO C RESISTANCE EQUALS 50 MEGOHMS.

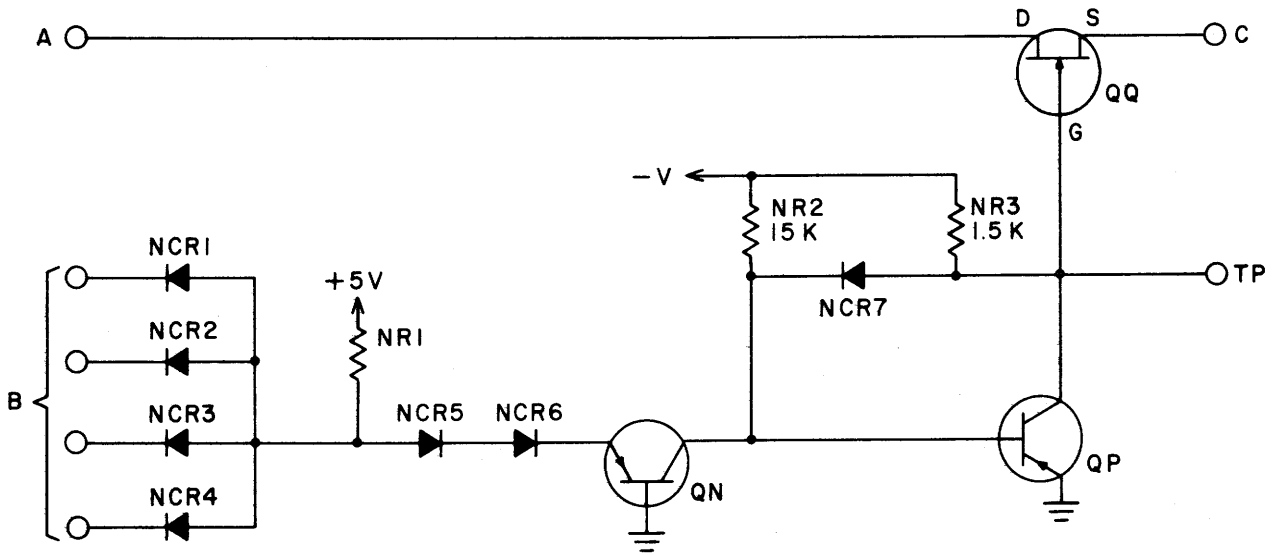

NOTE: VOLTAGE AND COMPONENT VALUES ARE FOR REFERENCE ONLY.

6T133

Figure 7-10. Multiple Gate Analog Clamp - GJC

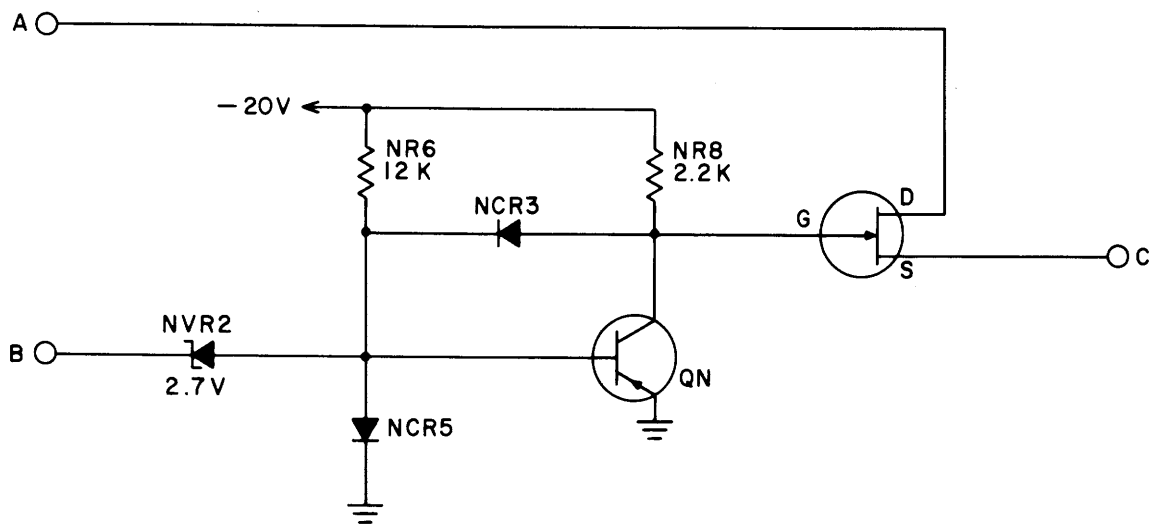
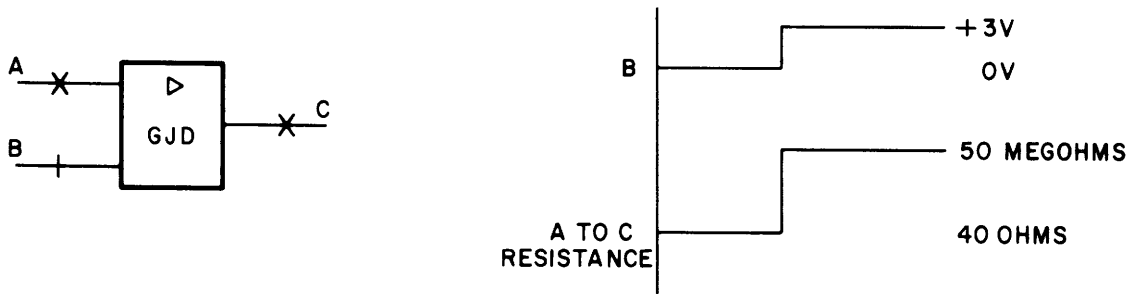

6T134

NOTE: VOLTAGE AND COMPONENT VALUES ARE FOR REFERENCE ONLY.

Figure 7-11. Gated Analog Clamp - GJD

Level Translator - GKA and Digital to Analog Converter - GKB

The GKA and GKB circuits (Figure 7-12) when used together comprise a 5-bit D/A converter. The GKB circuit used singly is a 4-bit converter.

The GKB consists of four voltage switches and a 4-bit R-2R D/A ladder network. Each voltage switch circuit applies positive voltage to the related ladder input when its input is a logical 1. A voltage switch applies ground to the related ladder network input when its input is a logical 0.

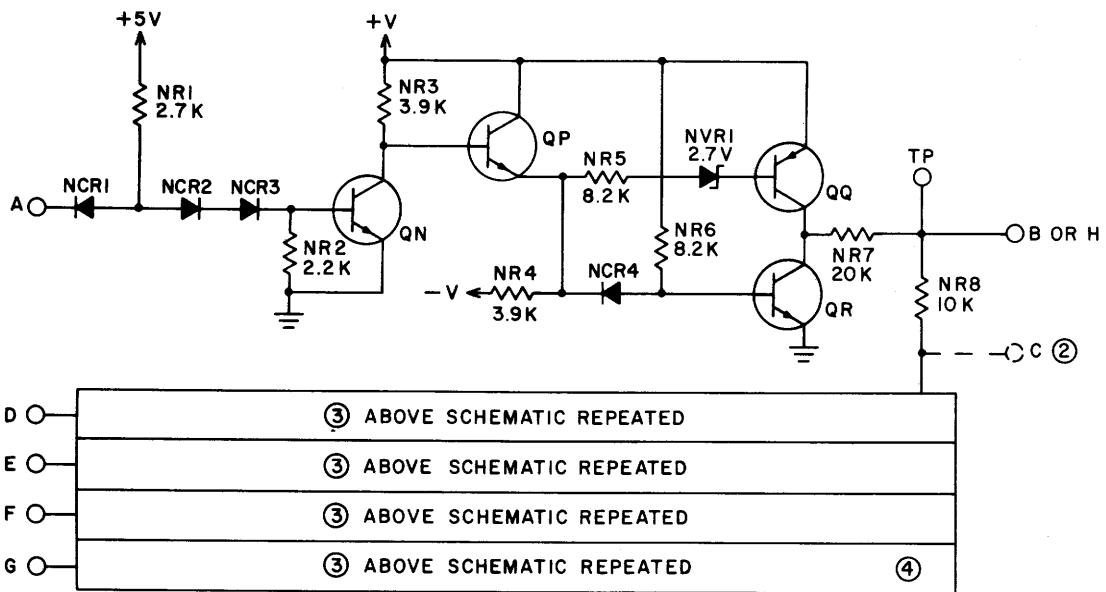
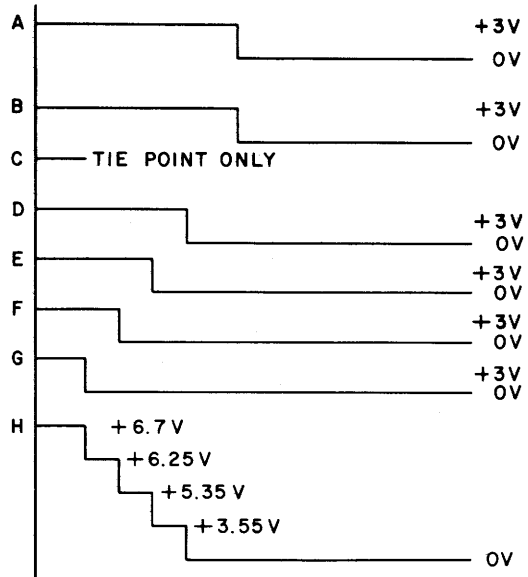
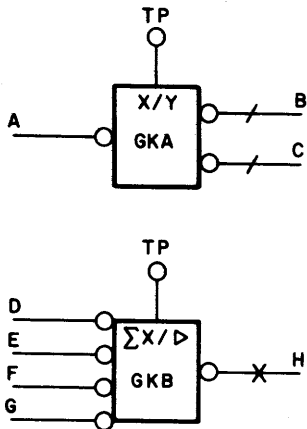

- NOTES: 1. VOLTAGE AND COMPONENT VALUES FOR REFERENCE ONLY.
 ② APPLICABLE TO GKA ONLY.
 ③ APPLICABLE TO GKB ONLY.
 ④ NR8 IN THIS SECTION IS 20K WITH LOWER END TO GROUND.

6T155

Figure 7-12. Level Translator and D/A Converter - GKA, GKB

In the GKB circuit, the digital inputs G, F, E, and D are ordered from least to most significant. When all digital inputs are "1's", the voltage at H is +6.7v (assuming a 10k ohm load is provided by the following circuit). When all digital inputs are "0's" the analog output is 0v (except for a +6 mv, max., dc offset). The analog output for an increase of one in the digital input code is +446 mv, nominal.

QN and QP operate as a saturated switch and an emitter follows, respectively, in the voltage switch circuit. QQ and QR operate as low offset saturated switches, only one of which is on at a time.

The R-2R D/A ladder has a resistance of 10k ohms from any node to ground and divides by two the voltage at the next lower, in significance, node.

The GKA circuit is identical to one stage of the GKB.

Level Translator - GKC

The GKC circuit (Figure 7-13) converts a logical 0 to a +2.15 (nominal) level used to inject a current signal into the summing point of an operational amplifier. Typically a resistor is connected between point B and the operational amplifier summing point to establish the magnitude of this current.

When a logical 1 is present at input A, transistor QN saturates, the output diode NCR4 shuts off, and output B drops to 0 volts removing the current to the operational amplifier summing point.

High Level Amplifier - HAA

The HAA circuit (Figure 7-14) is gated by an analog gate circuit (GJA) and provides the load and biasing for that circuit.

The preamplifier, ac feedback and dc feedback are identical to the FAB circuit. Capacitor CND is added to the output of the second stage to decouple high frequency noise.

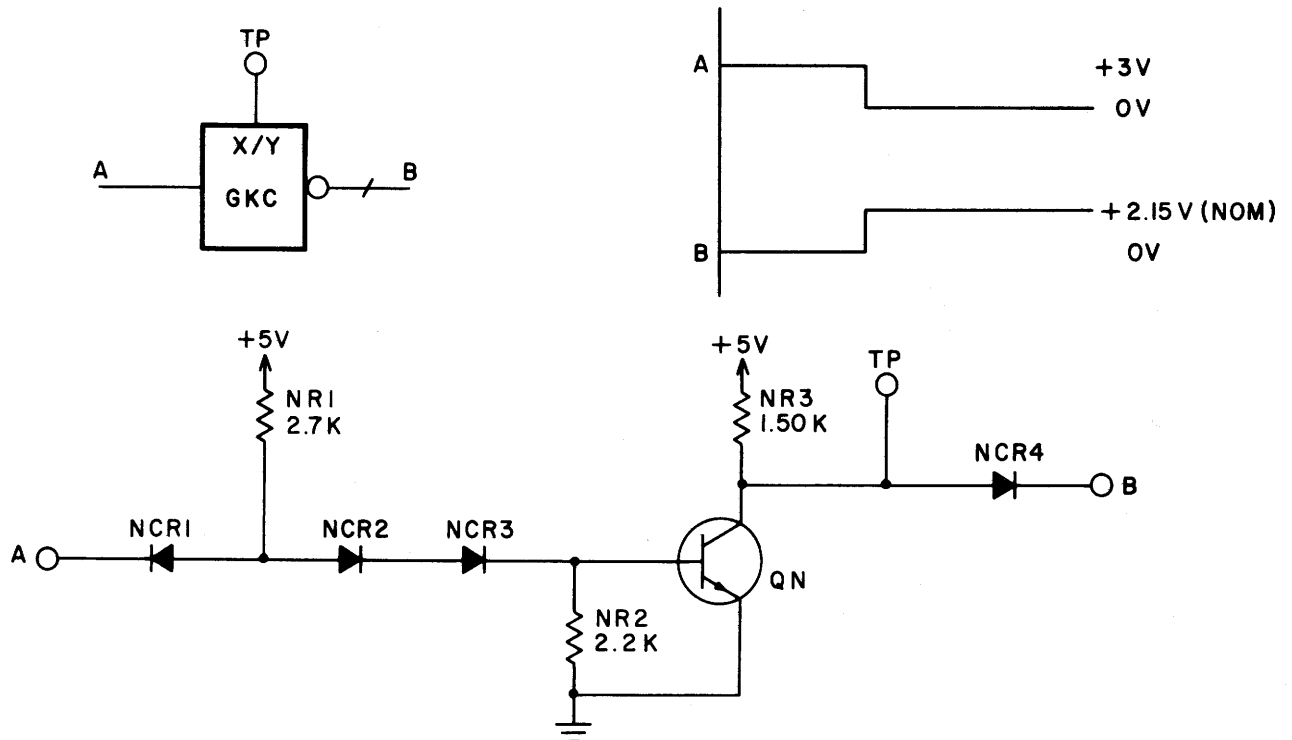

NOTE: VOLTAGE AND COMPONENT VALUES ARE FOR REFERENCE ONLY.

6T136

Figure 7-13. Level Translator - GKC

High Level Amplifier - HAB

Input to the HAB circuit (Figure 7-15) is a balanced square wave. Output is also a balanced square wave that follows the input.

When input A is positive, B is at 0v. Transistor QN is on and QP is off. The base of QQ falls to near ground. Transistor QQ is off. Output C rises to approximately +0.7v. With QP off, QR turns on. Output D falls to ground.

When input B is positive, A is at ground. Transistor QN is off, QP is on, QQ is on and QR is off. Output C is at ground. Output B rises to +0.7v.

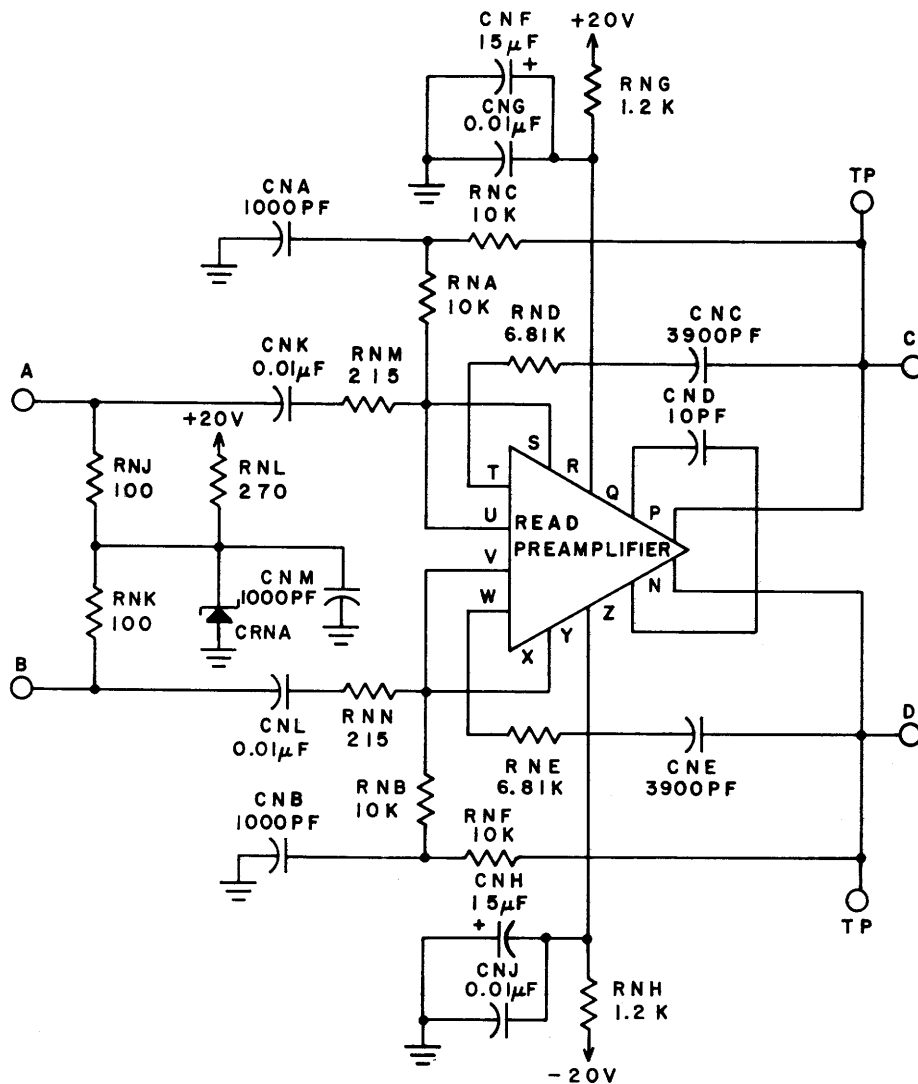
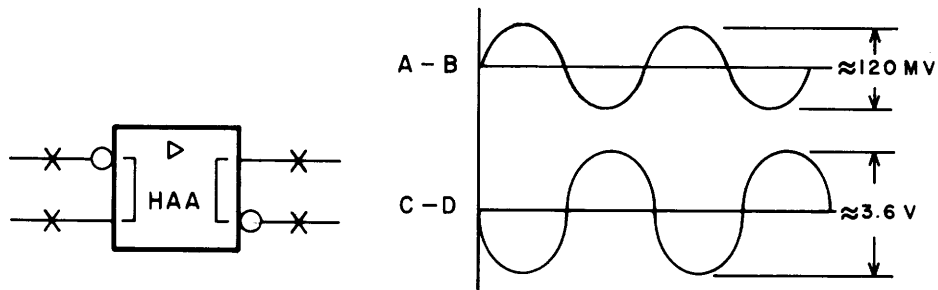

NOTE: VOLTAGE AND COMPONENT VALUES ARE FOR REFERENCE ONLY.

6T103

Figure 7-14. High Level Amplifier - HAA

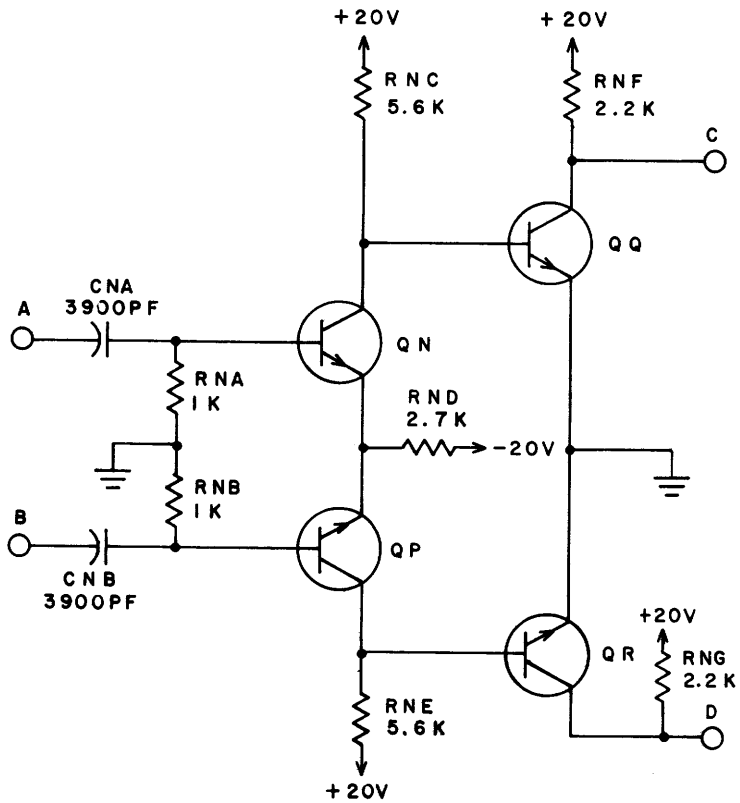
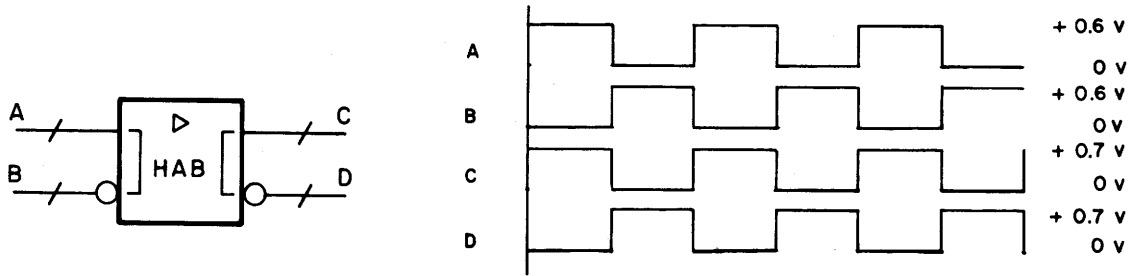

NOTE: VOLTAGE AND COMPONENT VALUES ARE FOR REFERENCE ONLY.

6T104

Figure 7-15. High Level Amplifier - HAB

High Level Amplifier - HJA

The HJA circuit (Figure 7-16) increases the input signal power to transmit over a coaxial cable. The input is a differential signal of approximately 3.6v peak to peak.

The input signal across A and B is divided between resistors RNA and RNB. Transistors QN and QP are forward biased with a gain of 3. The -20v through resistor RNH and diodes CRNA and CRNB and through resistor RNJ and diodes CRNC and CRND forward biases QQ and QT, respectively. Transistors QQ and QT are in a common collector configuration to provide a current gain.

Transistors QR and QS are emitter followers that draw very little current from QQ and QT. They provide low impedance for discharging CNC and CND, thus reducing delay time when crossing the zero volt point.

Output voltage is approximately the same as input voltage. Output current is 20 ma maximum.

Analog Power Amplifier - HJB

The HJB circuit (Figure 7-17) is designed to have a nominal gain of 1 (after trimming) at a frequency of 50 kHz.

The circuit consists of an input emitter follower (QN), a phase splitter (QP), and a class A quasi-complementary output stage (QQ and QR). Both the input and output are ac coupled.

A trimming resistor, NR2, is selected so that the output amplitude may be established at 15 volts pp.

The overall circuit phase shift at 50 kHz is 180 degrees. A negative feedback path (NC7 and NR16) provides circuit stability and gain limiting.

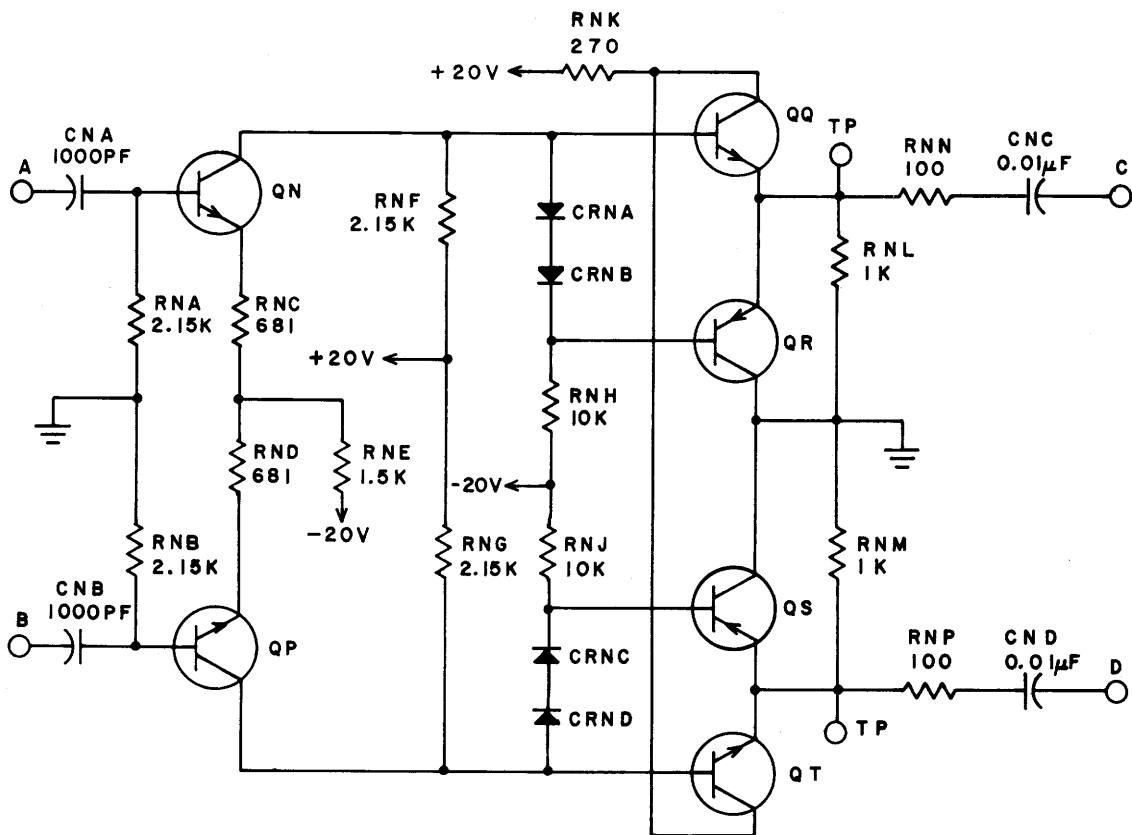
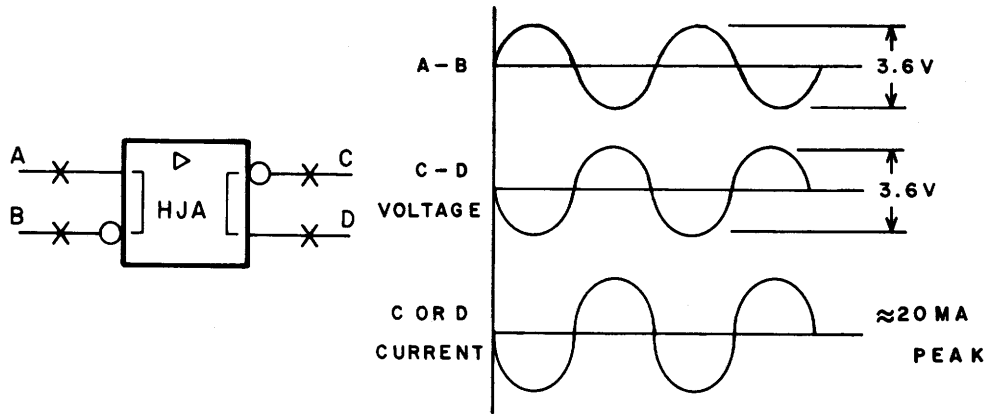

NOTE: VOLTAGE AND COMPONENT VALUES ARE FOR REFERENCE ONLY.

6T105

Figure 7-16. High Level Amplifier - HJA

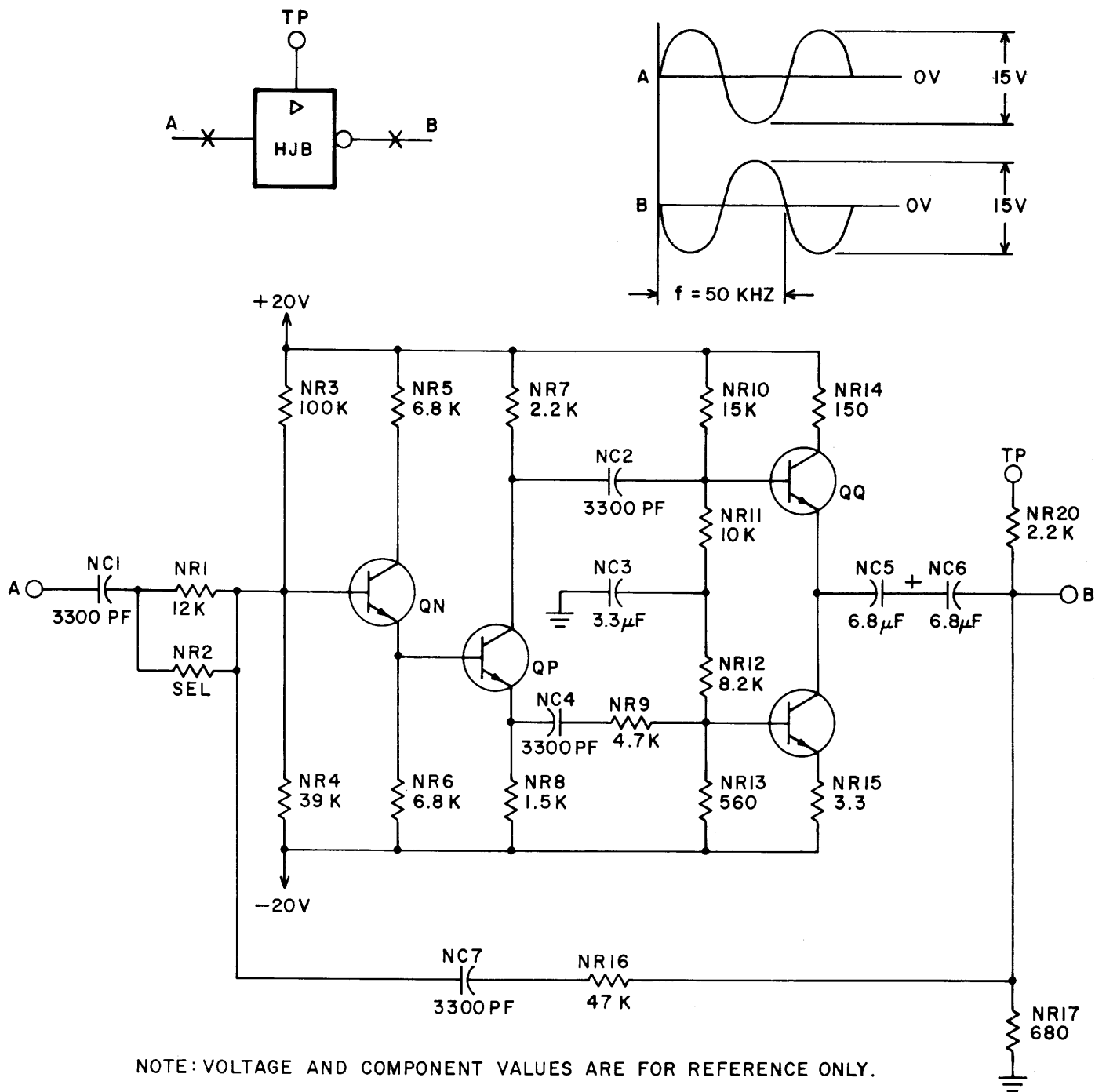

NOTE: VOLTAGE AND COMPONENT VALUES ARE FOR REFERENCE ONLY.

6T137

Figure 7-17. Analog Power Amplifier - HJB

Differential Amplifier - HJC

The HJC circuit (Figure 7-18) is a differential amplifier with a voltage gain of 5 (14 db). The input/output waveforms shown on the figure are drawn for a situation where the track servo head is positioned between two tracks (of 406 tracks prerecorded alternately at 455 and 500 kHz) of the track servo disk pack surface. The beating together of the two frequencies causes the signal amplitude changes. The signal at maximum amplitude is an equal mixture of the 455 and 500 kHz frequencies.

Transistors QP and QQ constitute a current source for the differential amplifier. Signal amplification occurs at transistors QN and QR. Transistors QS, QT, QU, and QV are the current buffers for the outputs.

Amplifier/Level Translator - HJD

The HJD circuit (Figure 7-19) is an amplifier that provides a half-wave rectified, shifted output signal.

The output signal at B increases in a positive direction from a -3 vdc level. The output signal controls a N-channel JFET in an AGC loop that regulates the amplitude of the fine position servo signal.

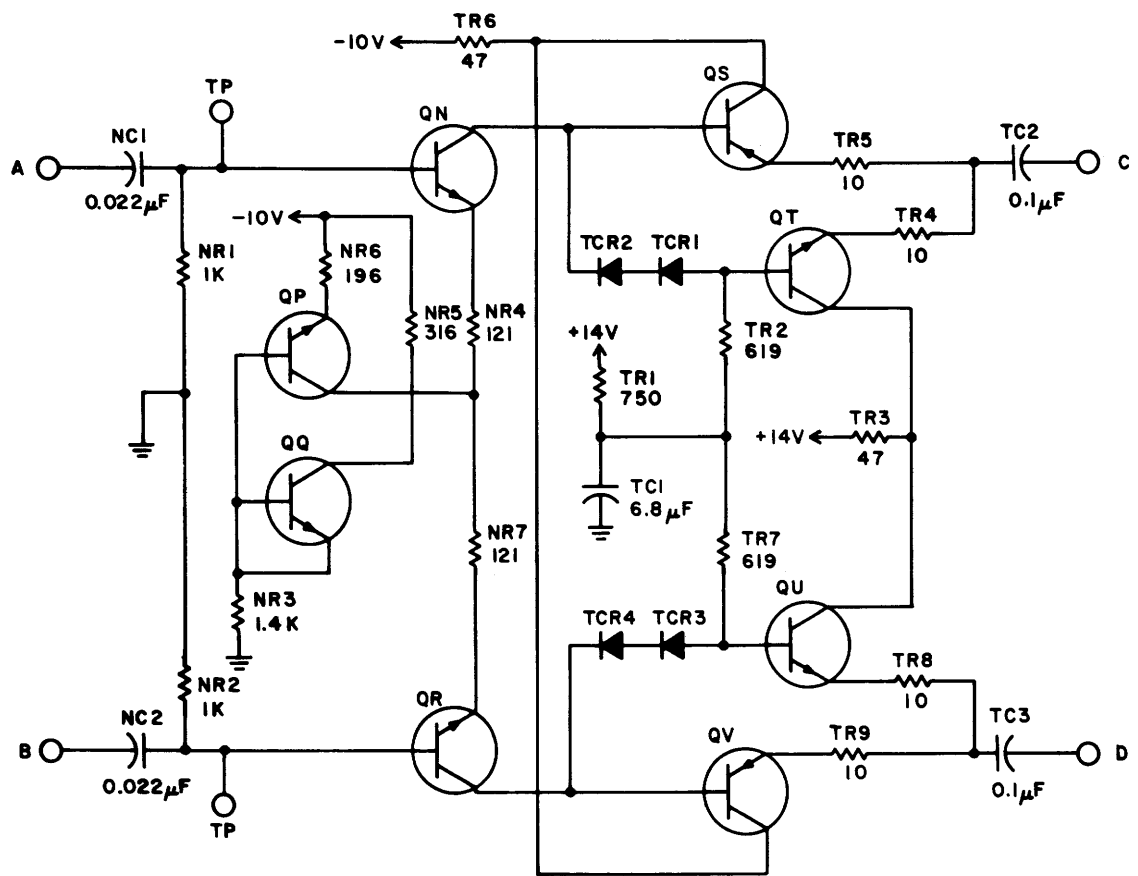
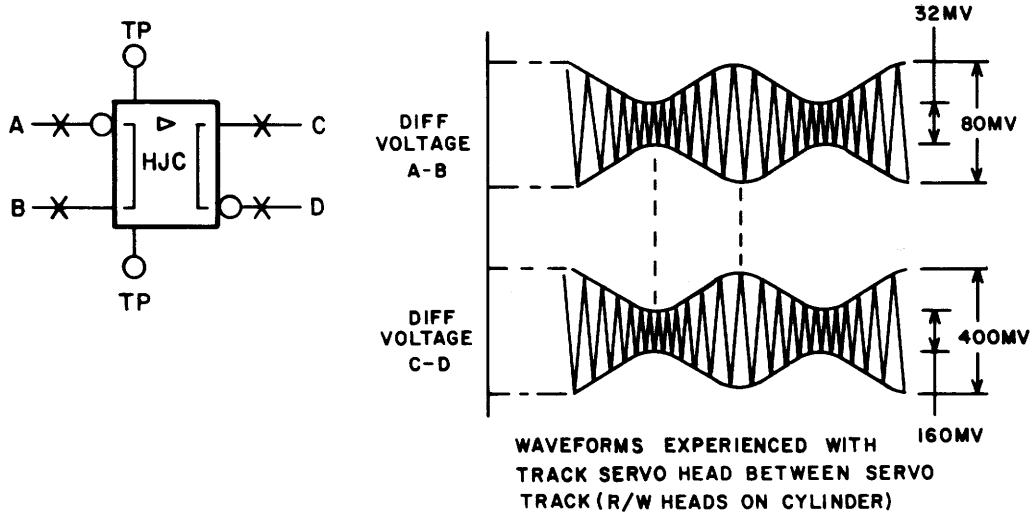

NOTE: VOLTAGE AND COMPONENT VALUES ARE FOR REFERENCE ONLY. 6T168

Figure 7-18. Differential Amplifier - HJC

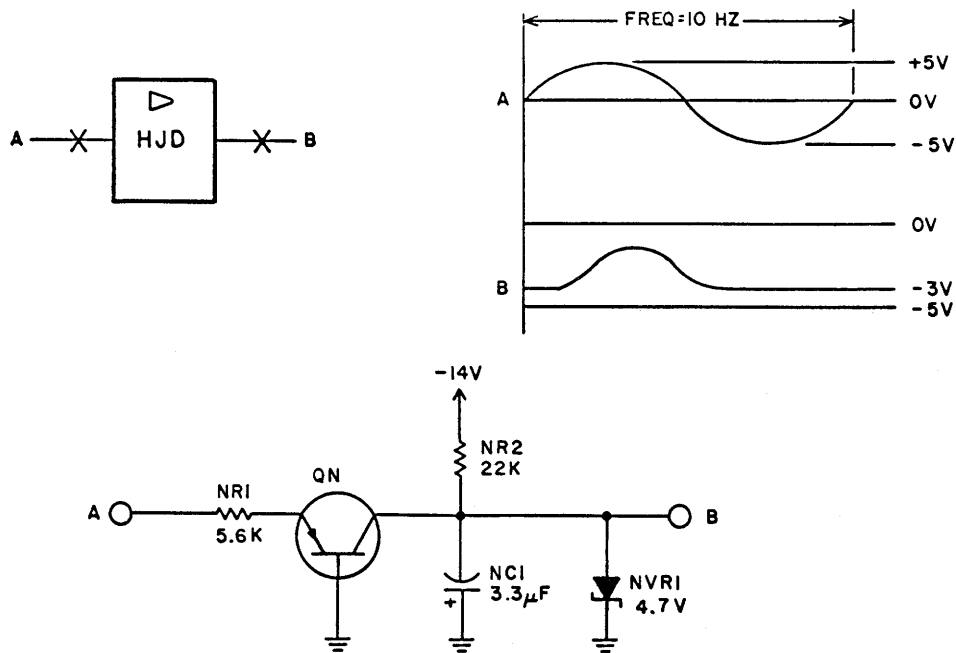

NOTE:
VOLTAGE AND COMPONENT VALUES ARE FOR REFERENCE ONLY

6T167A

Figure 7-19. Amplifier/Level Translator - HJD

Level Translator - HJE

The HJE circuit (Figure 7-20) converts the output of an operational amplifier to a standard logic level.

When input A is at -12 volts, transistor QN is on. Diode NCR2 limits the input voltage at the base of QN to approximately -0.7 volt. Since the base to emitter voltage of QN is +0.8 volt, output B is at a level of approximately +0.1 volt.

When input A switches to +12 volts, QN becomes reverse biased and output B approaches +5 volts. The base voltage of QN is limited to approximately +5.7 volts by diode NCR1.

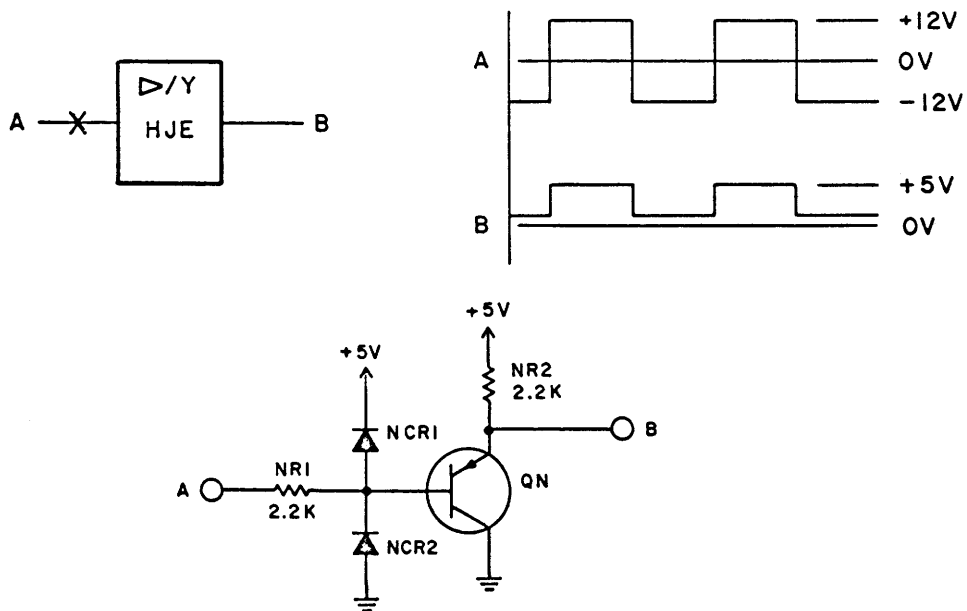

NOTE:

VOLTAGE AND COMPONENT VALUES ARE FOR REFERENCE ONLY.

6T166A

Figure 7-20. Level Translator - HJE

Differential Amplifier - HJF

The HJF circuit (Figure 7-20.1) is a differential amplifier with a voltage gain of 5 (14 db).

Signal amplification occurs at transistors QN and QP. Transistors QQ and QR are the current buffers for the outputs.

Differential Amplifier - HJG

The HJG circuit (Figure 7-20.2) is a differential amplifier with a voltage gain of 13 (22.3 db).

Transistors QP and QQ constitute a current source for the differential amplifier.

Signal amplification occurs at transistors QN and QR.

Transistors QT and QS are the current buffers for the outputs.

Differential Amplifier - HJH

The HJH circuit (Figure 7-20.3) is a differential amplifier with a voltage gain of 5 (14 db). The input/output waveforms shown on the figure are drawn for a situation where the track servo head is positioned between two tracks (of 406 tracks prerecorded alternately at 455 and 500 kHz) of the track servo disk pack surface. The beating together of the two frequencies causes the signal amplitude changes. The signal at maximum amplitude is an equal mixture of the 455 and 500 kHz frequencies.

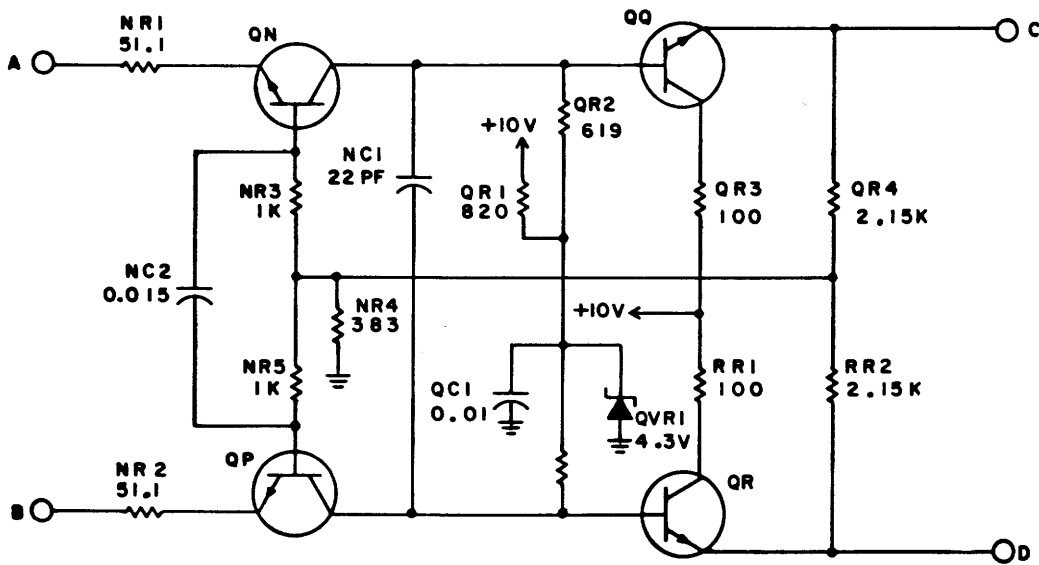
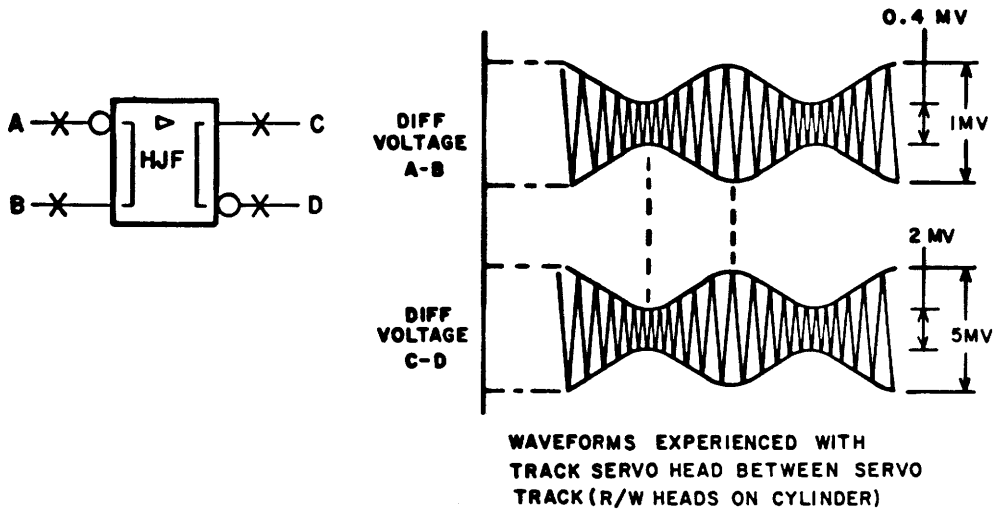

NOTE: VOLTAGE AND COMPONENT VALUES ARE FOR REFERENCE ONLY.

67170

Figure 7-20.1. Differential Amplifier - HJF

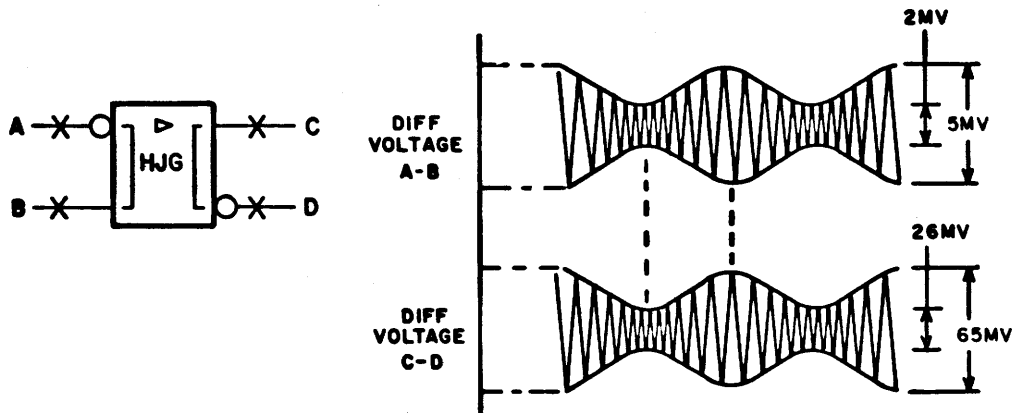

WAVEFORMS EXPERIENCED WITH TRACK SERVO HEAD BETWEEN SERVO TRACK (R/W HEADS ON CYLINDER)

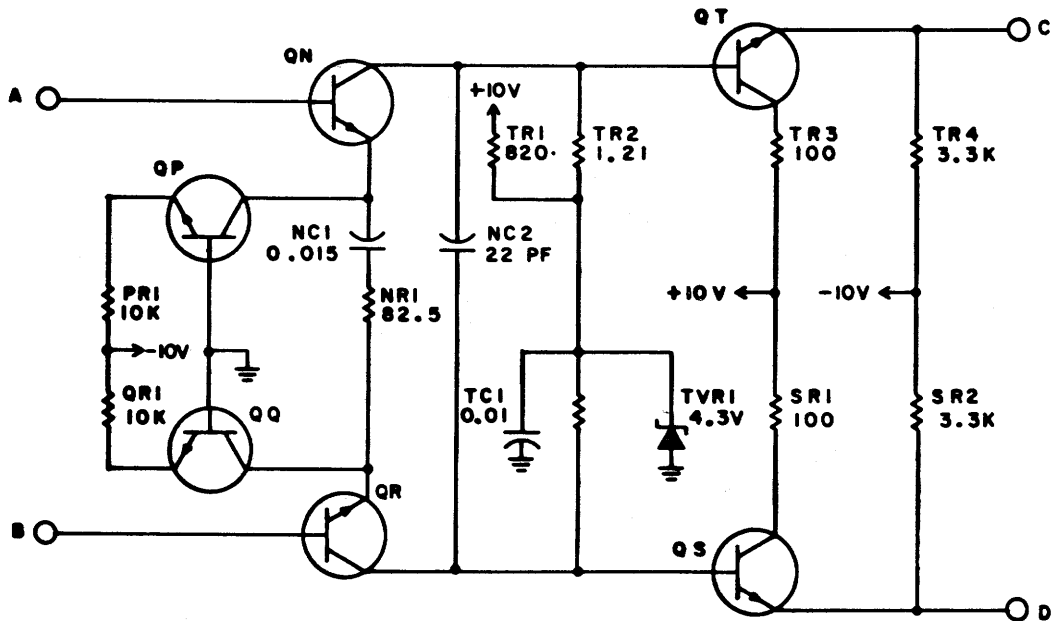

NOTE: VOLTAGE AND COMPONENT VALUES ARE FOR REFERENCE ONLY.

6T171

Figure 7-20.2. Differential Amplifier - HJG

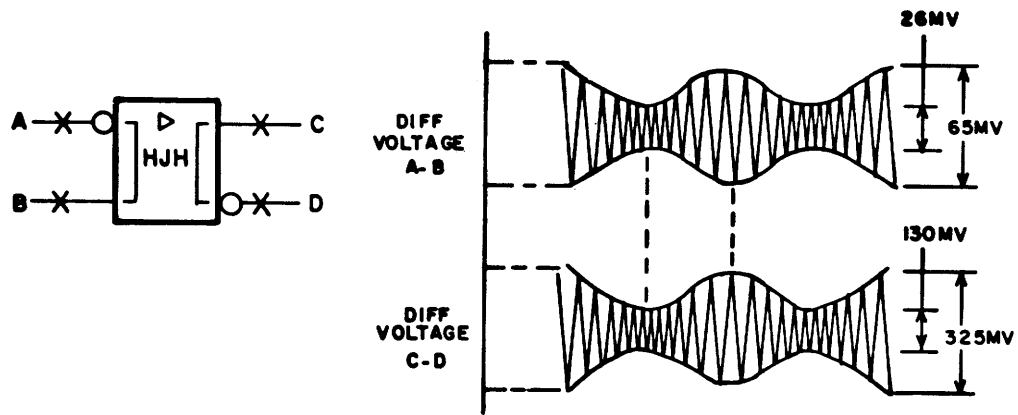

WAVEFORMS EXPERIENCED WITH TRACK SERVO HEAD BETWEEN SERVO TRACK (R/W HEADS ON CYLINDER)

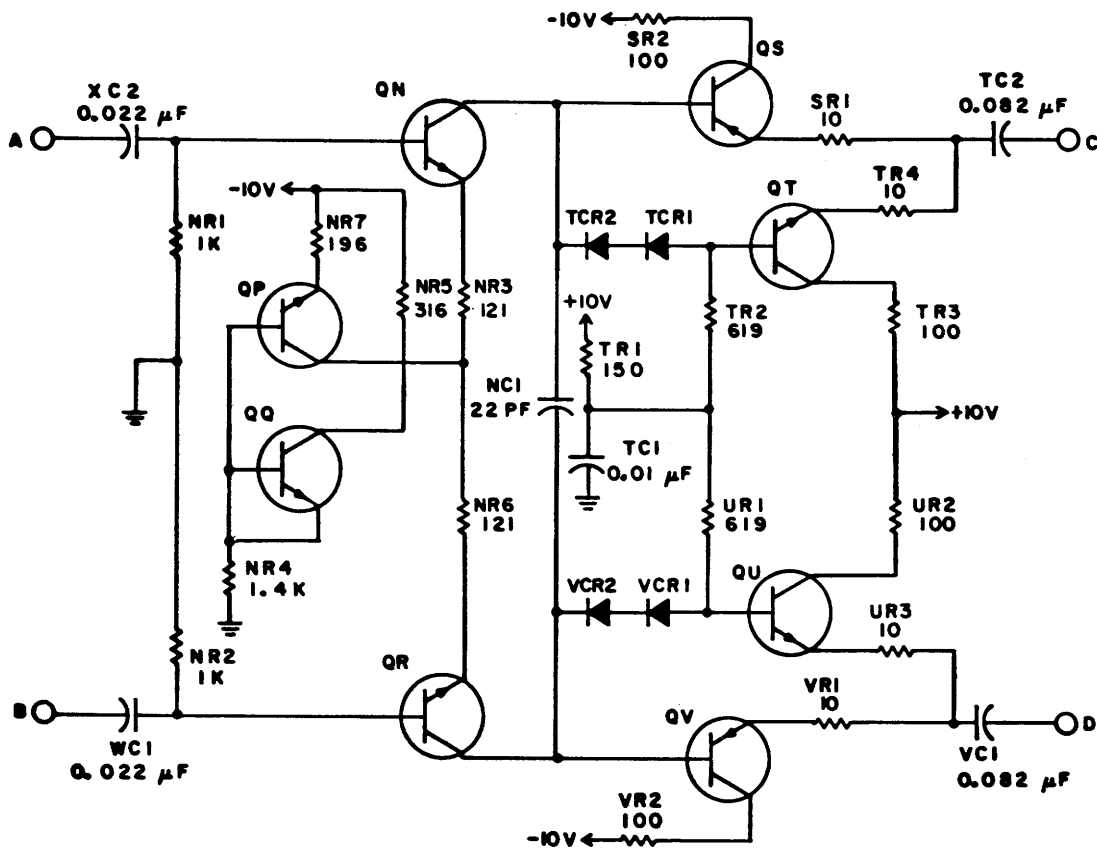

NOTE:

VOLTAGE AND COMPONENT VALUES ARE FOR REFERENCE ONLY.

67172

Figure 7-20.3 Differential Amplifier - HJH

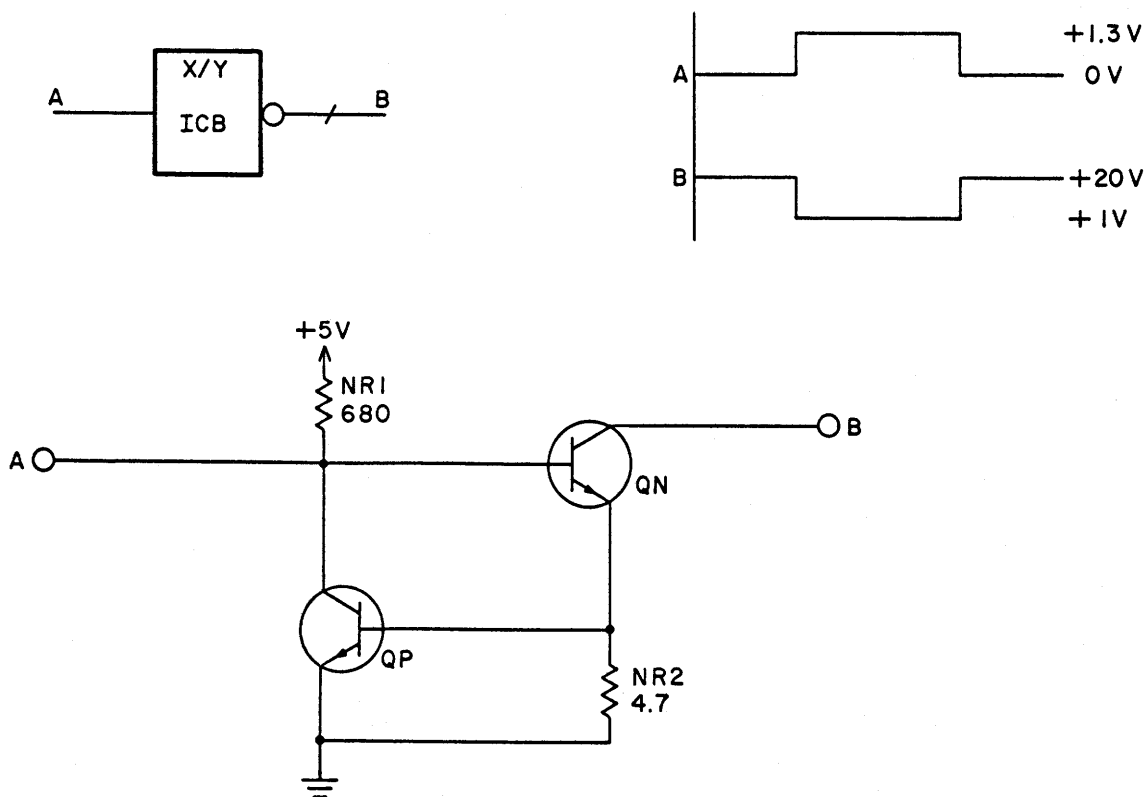

NOTE: VOLTAGE AND COMPONENT VALUES ARE FOR REFERENCE ONLY.

8T148

Figure 7-21. Lamp Driver - ICB

Lamp Driver - ICB

The ICB circuit (Figure 7-21) drives a lamp which terminates at +20 volts. The circuit is (and must be) driven by an open collector integrated circuit. The nominal current of the lamp must not exceed 100 ma.

QP and NR2 serve as a current limiter. When approximately 140 ma flows through NR2, QP turns on and diverts base current from QN to ground. This prevents surge currents of greater than 140 ma.

When a high, logic 1, is provided to the circuit input, transistor QN (and the lamp) turns on.

A low (logical 0) at the input turns QN off causing the circuit output to rise to the lamp termination voltage. With no path to ground available, the lamp turns off.

Write Driver - JAB

The JAB circuit (Figure 7-22) provides current to the write heads so that data may be recorded. Outputs E and F are connected to opposite ends of the write head, which is center tapped to ground. When input A is positive, current flows through output E to its half of the write head. When input B is positive, current flows through output F to its half of the write head. When A is positive and the unit is writing, B is negative. When A is negative and the unit is writing, B is positive. Therefore, only one half of the write head may be activated at any one instant while the unit is writing.

With a positive charge on input A, transistor QN is off. The base of QR is positive and the emitter of QS is positive. The negative voltage at B turns transistor QT on. This drives the emitter of QR negative. Transistor QR conducts, driving the base of QQ to about -2v. Transistor QQ is an emitter follower, so the emitter of QQ is also near -2v. The -2v on the base of QP turns QP off. No current flows through output F (-20v through resistor RNA only reverse biases an external diode). With QT on, the base of QS goes slightly negative. Transistor QS is off, allowing the base of QU to go to +40v. Transistor QU is an emitter follower, so the emitter of QU also goes to about +40v. The +40v on the base of QV turns QV on. Current now flows from a +40v supply connected to output G through transistor QV and its half of the write head to ground. A resistor lies between output E and the write head to limit the current flow in the write head.

When input A goes negative and B goes positive, QN and QS are on and QR and QT are off. On the bases of QQ and QU are currents of +40v and -2v, respectively. The emitter of QQ goes to about +40v. The emitter of QU goes to about -2v. Transistor QV is off. No current flows through output E. Transistor QP is on. Current flows from the +40v source connected to output G through QP and its half of the write head to ground.

Input D supplies a negative voltage when the unit is writing to reverse bias diodes CRNA and CRNF. If the unit is not writing, D is grounded and both inputs A and B go negative. This turns on QR and QS. Transistors QP and QV are, therefore, off and no current flows through the write head.

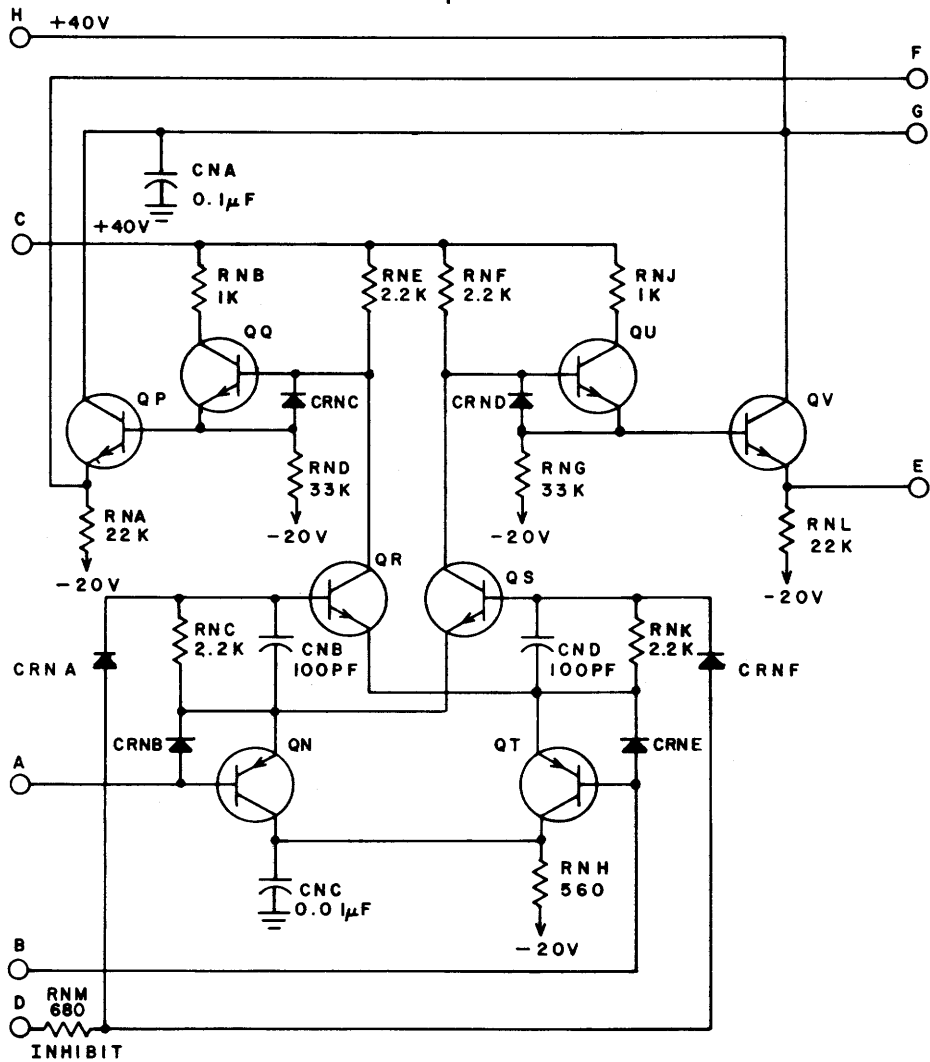
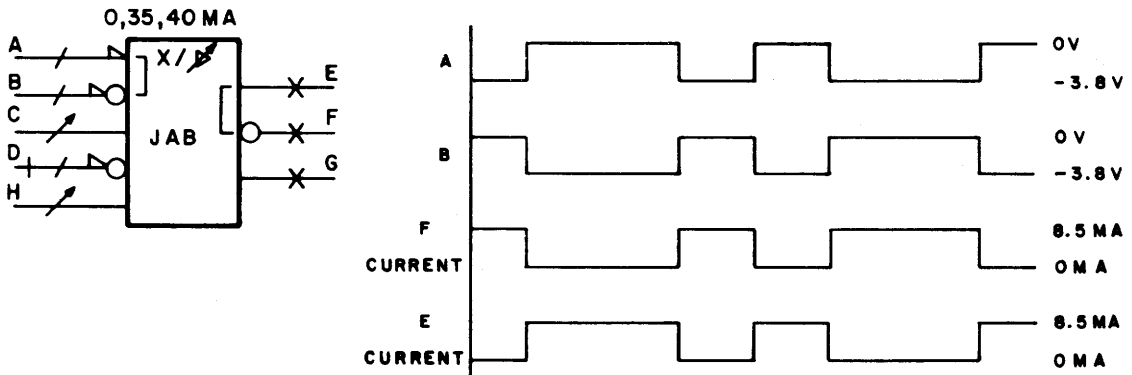

NOTE: VOLTAGE AND COMPONENT VALUES ARE FOR REFERENCE ONLY.

6T106

Figure 7-22. Write Driver - JAB

Write Driver - JAD

The JAD circuit (Figure 7-23) provides the write current to the read/write heads during a write operation. Circuit outputs E and F are connected across a pair of series-connected, write coils. When input A is positive, current flows from output E to ground via one of the coils. When input B is positive, current flows from output F to ground through the other coil.

When a positive signal is present at input A, QN turns on dropping the collector of QN to near zero volts. This causes QP to turn off and no current flows at output F. At this same time QR is off since input B is at zero volts. Base drive is applied to QQ via resistors NR5 and NR3 and as a result is on. With QQ on, current flows from output E. (This current is limited by external resistors connected between E and F and their respective coil.) When the inputs are reversed (B positive and A at zero volts) the circuit conditions reverse, and current flows from F. Transistor QS, and related components, provide a constant current source for the emitters of QN and QP.

Input C functions as an inhibit to the circuit. Input C must be at a +40-volt level when a write operation is in progress. When a write operation is not occurring, C is at zero volts and the bypass action of diodes NCR1 and NCR2 prevents base drive to both QP and QQ. This action stops current flow from both outputs E and F.

The level of current used during a write operation is selected by external circuits in accordance with the track location of the heads. If the actuator has positioned the heads to a track between, and including, 0 and 127, write current (at input H) is derived from +40 volts. If the heads are at track 128 or above, input H is at +35 volts and the available write current is reduced.

Output G provides write current to an external current monitor circuit.

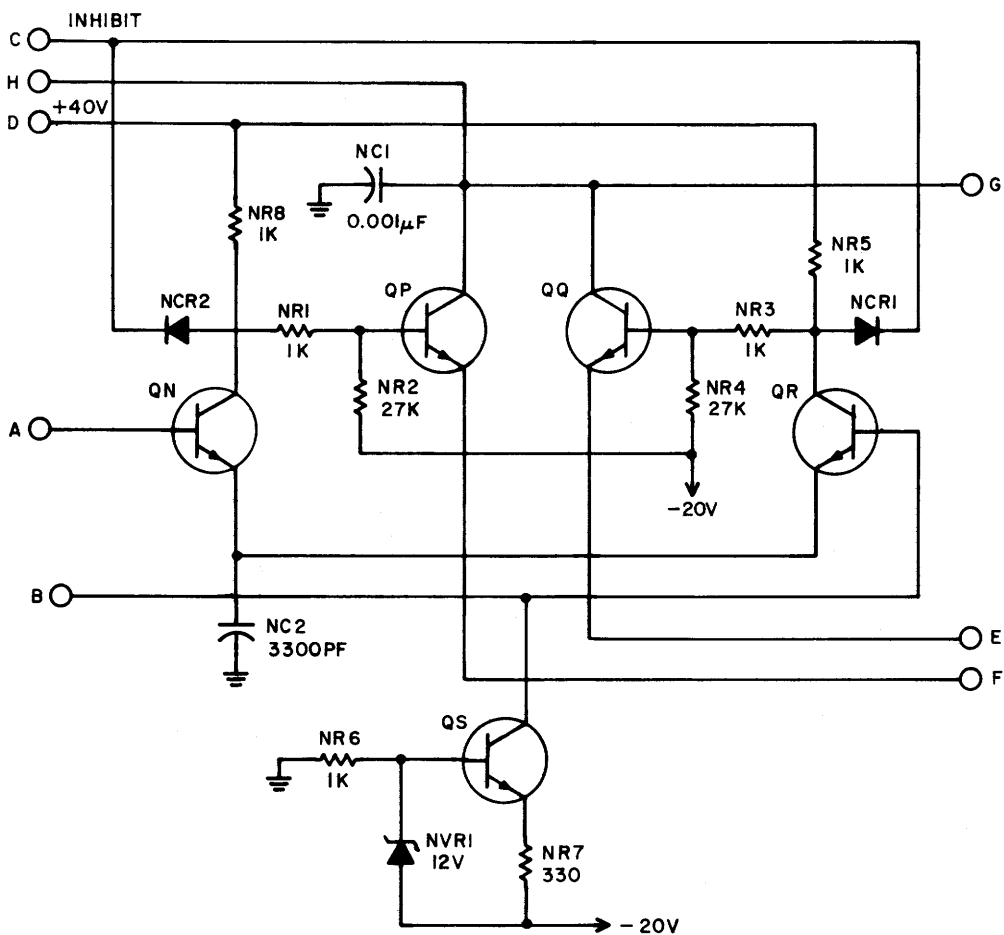
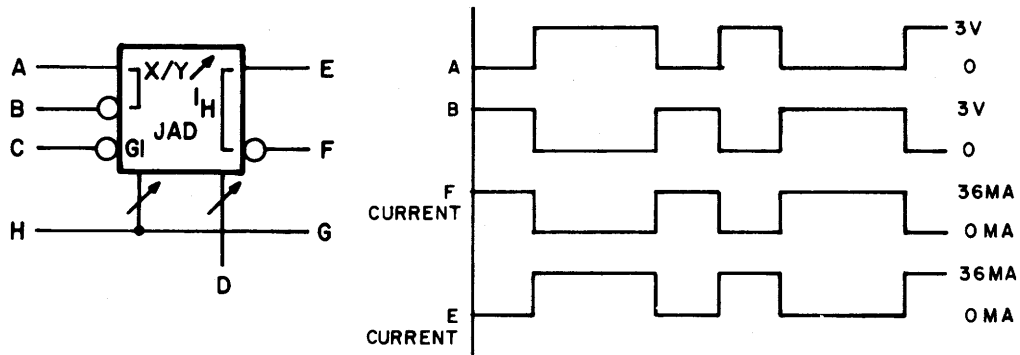

NOTE:

I. VOLTAGE AND COMPONENT VALUES FOR REFERENCE ONLY

6T152

Figure 7-23. Write Driver - JAD

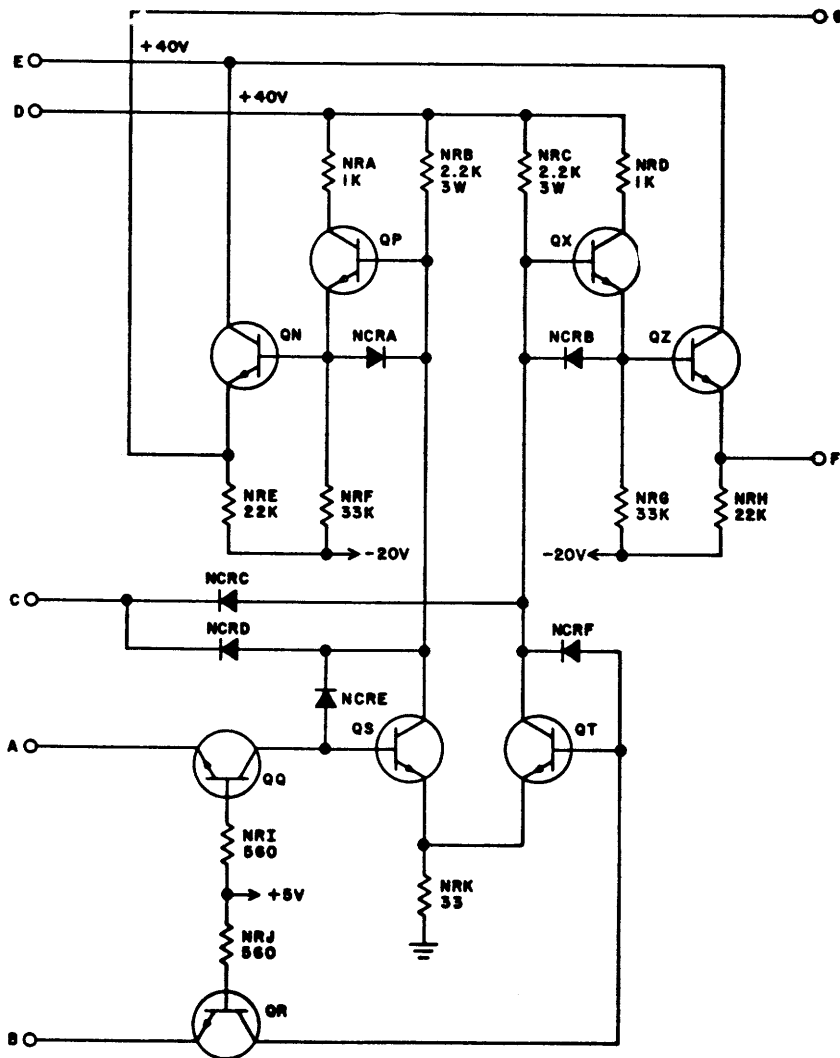
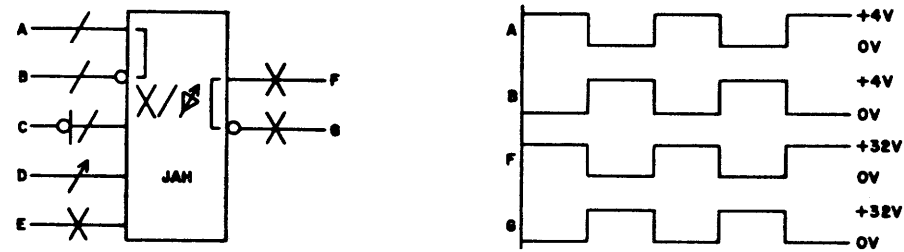

NOTE: VOLTAGE AND COMPONENT VALUES ARE FOR REFERENCE ONLY.

7K35

Figure 7.23.1. Write Driver - JAH

Write Driver - JAH

The JAH circuit is a symmetrical driver that amplifies the write signal for recording on the disk. Points A and B are inputs to the driver. Points F and G are outputs. Point C is the write gate input. Points D and E go to +40 vdc switched through an external resistor.

Transistors QQ and QR connect to a toggle FF as an interface to the driver transistor QS and QT. With the input at A high (+4 vdc), QQ is reverse biased, base to emitter. Current flows from base to collector and turns on QS. At the same time, input B is low (ground) which turns QR on. This puts a ground at the base of QT, holding it off.

Transistors QN and QP are a darlington pair with the drive for QN coming from QP. When QS is on, QN is off because the base of QP is pulled to ground by QS. QZ, QX, and QT work in the same manner.

Diodes NCRA and NCRB speed up the turn off of QN and QZ by removing the base-emitter charge.

Diodes NCRC and NCRD are gating diodes that put a clamp to ground at the base of QP and QX when a ground is placed at point C.

Diodes NCRE and NCRF are antisaturation diodes that keep transistors QS and QT from saturation.

Erase Driver - JBB

The JBB circuit controls the current driving the erase heads. When input E (Figure 7-24) is a high voltage, output H provides current to erase heads.

When input E goes to a high voltage, capacitor CPA charges, causing a 10-usec delay before transistors QR and QP turn on completely. Output G is connected to a +40v supply in a fault detect circuit. When QR is on, current flows from G through QR to the erase head connected to output H. The ramp output protects the information on neighboring tracks from being destroyed.

When E drops to 0v, CPA discharges through RPA. After 10 usec, QP and QR are off. Output H is at 0v.

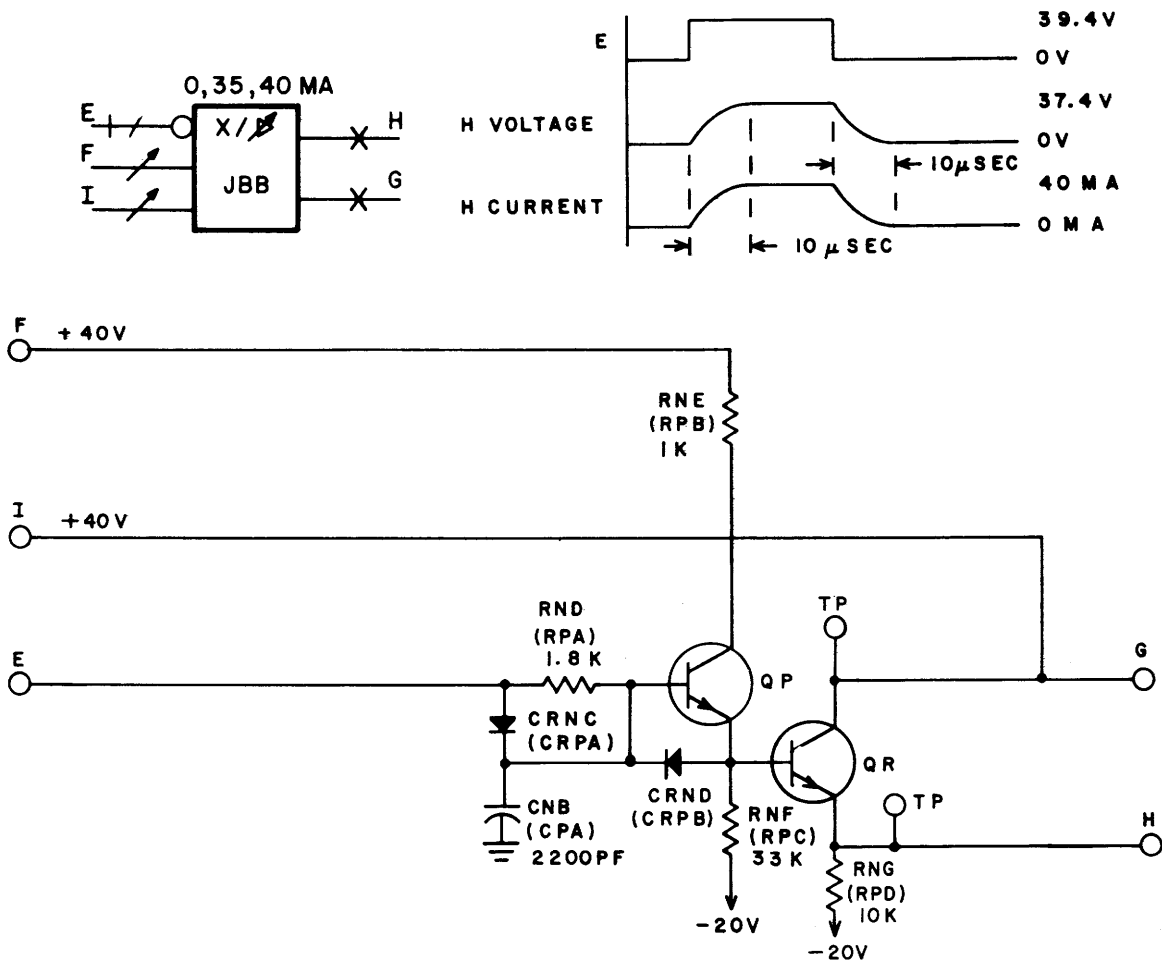

NOTES:

1. VOLTAGE AND COMPONENT VALUES ARE FOR REFERENCE ONLY.

6T107

Figure 7-24. Erase Driver - JBB

Line Transmitter - LCA

The LCA circuit (Figure 7-25) provides a positive output at B and a negative output at C when input A is low. When the input is high, outputs B and C are at ground.

The circuit is (and must be) driven with an open collector integrated circuit. The LCA circuit input is a differential stage (QN and QP) which sinks the current from the minus and plus constant current sources (QQ and QR) whenever input A is high. When A is high, QN and QP are off and the 25 ma of current from the constant current sources is routed through the emitters of the differential output stages (QS and QT) to the outputs B and C. External Zener diodes on the plus and minus voltage supply lines serve as a common voltage divider for all circuits on one card and provide bias voltage to the constant current sources and the output transistors.

The complementary current sink (QN and QP) monitor a close phase relationship during turn-on and turn-off by having the emitter of QN (NPN) drive the emitter of QP (PNP). Returning the external resistor on the circuit input to +20 volts, instead of +5 volts, ensures that QN and QP will sink the drive current if the +5-volt power is lost.

NCR2, NCR4, NR7, and NR13 protect the transmitter if large externally produced transients should appear on the output lines.

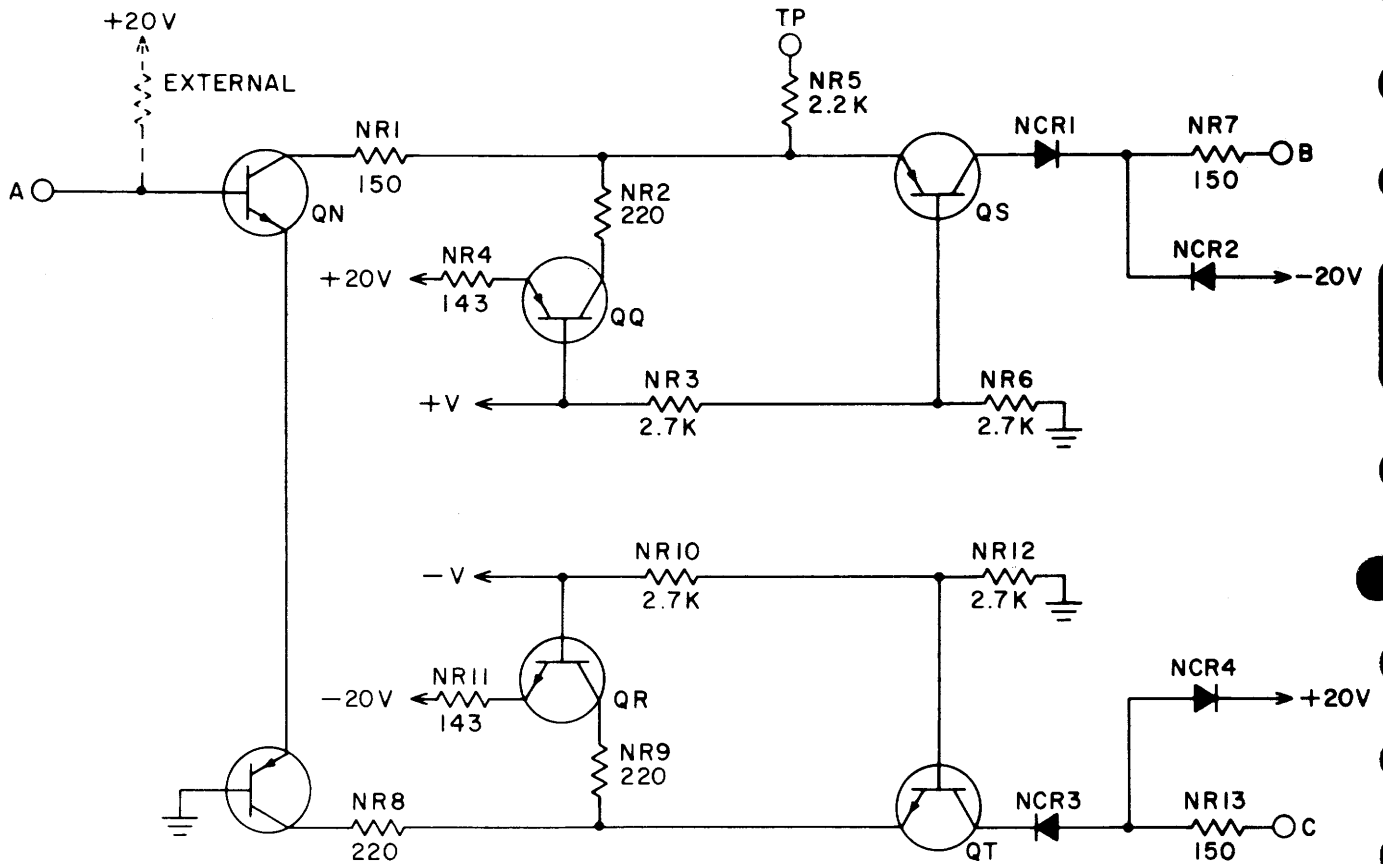
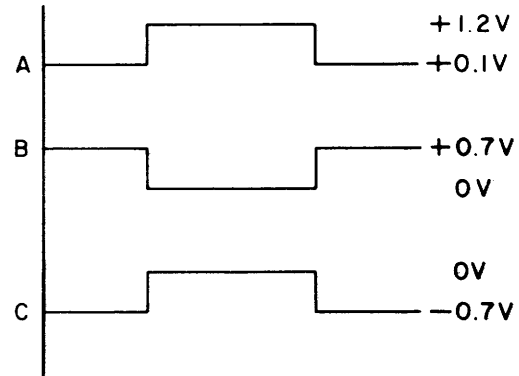
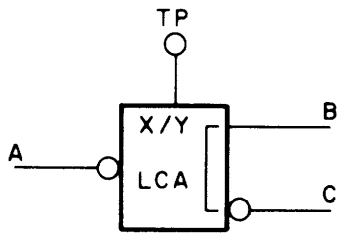

NOTE: VOLTAGE AND COMPONENT VALUES ARE FOR REFERENCE ONLY.

6T147

Figure 7-25. Line Transmitter - LCA

Line Transmitter - LCB

The LCB circuit (Figure 7-26) is a Q-level party-line transmitter that sinks current from the output line, B, to -3 volts when input A is at zero volts. When A is positive, transistor QN is reverse biased and both QN and QP are off. Capacitor PC1 controls the output rise and fall times.

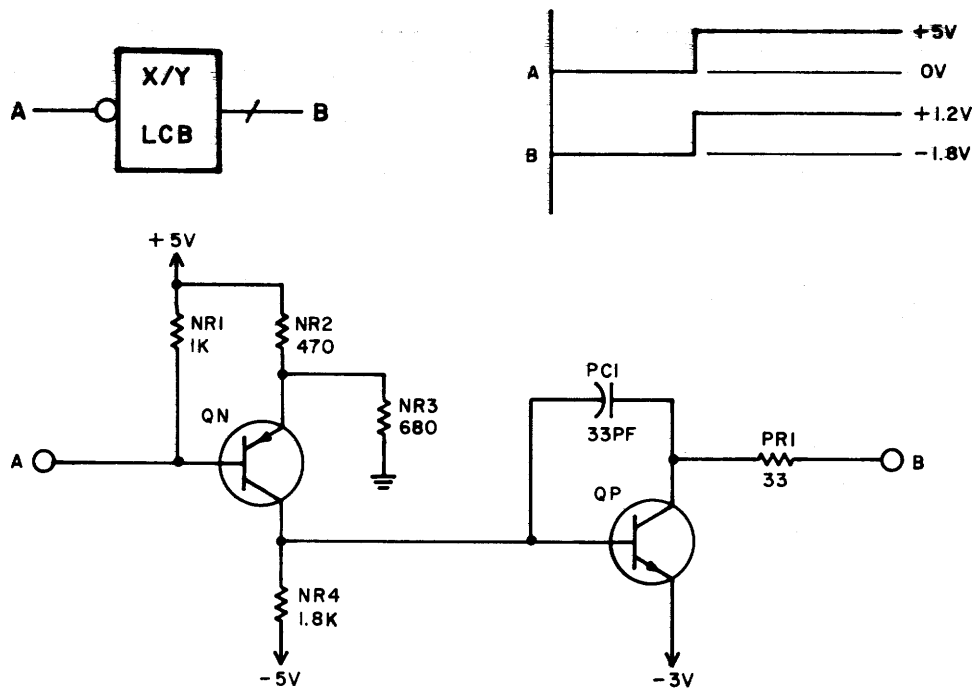

NOTE :

1. VOLTAGE AND COMPONENT VALUES FOR REFERENCE ONLY

6T153

Figure 7-26. Line Transmitter - LCB

Oscillator - MAC

The MAC circuit (Figure 7-27) produces an amplified, oscillating signal at a prescribed frequency. The circuit description is divided into three parts: the D.C. conditions throughout the circuit; the oscillator section of the circuit; and the amplifier circuit.

D.C. Conditions

CRNA, RNA, RNB and RND hold the base of QN at approximately +17 volts. CRNB is reverse biased by 3 volts and does not conduct. The emitter of QN is held at about +16v, producing a collector current in QN of about 16 ma.

The base-emitter voltage drop across QR holds the base of QR near +0.7v. The current through RNH is then 5.1 ma. With the base current of QR at a low level, the 5.1 ma must flow through RNJ. The voltage at the junction of the emitters of QP and QS must then be about +10v. To maintain this +10v, the collector voltage of QR must be near +10v. The collector current of QR is, therefore, 5.55 ma.

Oscillator

Transistor QN acts as an emitter follower yielding a high current gain with nearly no voltage loss. CNB, CNC, and LNA form a resonant network. Near the resonant frequency, the signal voltage at the junction of LNA and CNB can be much greater than the voltage through RNE in the feed-back portion of the circuit. The gain around the loop formed by QN, RNE, CNB and LNA is greater than 1. The system, therefore, oscillates. When the signal at the base of QN exceeds 6v peak to peak, QN approaches saturation, thereby limiting the amplitude of the oscillation.

Amplifier

Transistor QR is the basic amplifier providing a voltage gain of about 2. Diodes CRNC and CRND keep QP biased in its active region while keeping QS biased slightly on. QP and QS are emitter followers that provide a low impedance output. As the voltage at the base of QP increases, the output voltage increases and charges the output capacitance. RNP is essentially the emitter follower resistance. As the base voltage decreases, QS turns on harder and provides a low impedance path to ground to discharge the capacitance and thereby provide an undistorted sine wave output. Capacitors CND and CNF provide dc isolation, and CNE and CNG are bypass capacitors.

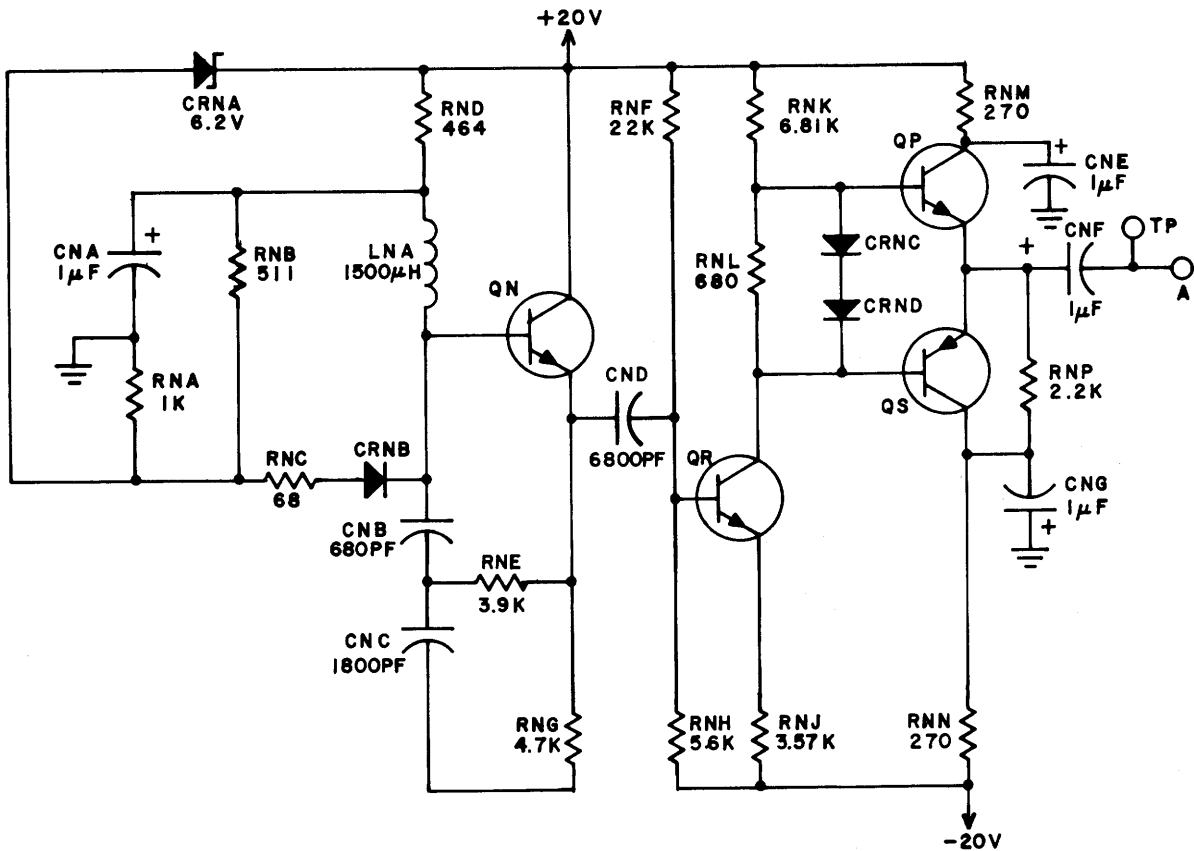
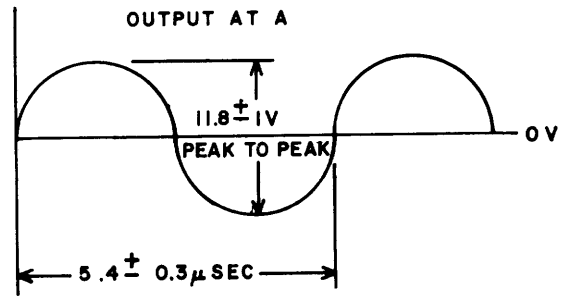
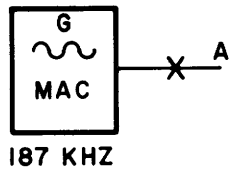

NOTE:
VOLTAGE AND COMPONENT
VALUES FOR REFERENCE ONLY.

6T108

Figure 7-27. Oscillator - MAC

Oscillator - MAD

The MAD circuit (Figure 7-28) consists of a tuned voltage amplifier stage, QP, and a series tuned regenerative feedback path. The regenerative feedback path consists of a series tuned 50 kHz crystal, an impedance transformer (QN as an emitter follower), and a series LC pass network (NC4 and NC2). The nominal output amplitude is 15 volts peak-to-peak.

Oscillator - MAG

The MAG circuit (Figure 7-28.1) is a 50 kHz sine wave oscillator capable of supplying a 20V p.p. signal to point A.

The circuit is composed of three main functional blocks. Amp 1 is a narrow pass band filter operating at 50 kHz. Amp 2 is a gain of 0.89 inverting amplifier. Transistor QN and its associated circuitry is a level controlling AGC circuit.

360° of phase shift on the oscillator circuit is accomplished by 180° on the bandpass filter and 180° on the Amp 2.

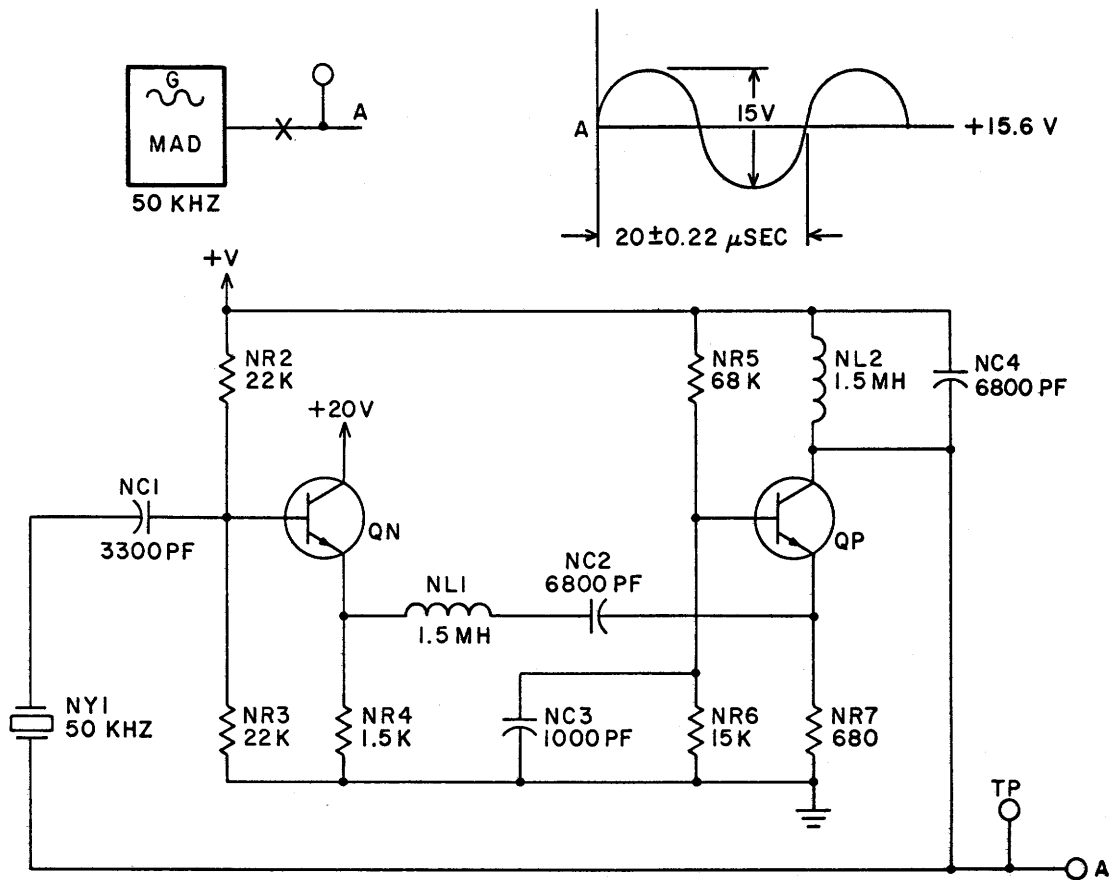

NOTE: VOLTAGE AND COMPONENT VALUES ARE FOR REFERENCE ONLY.

6T138

Figure 7-28. Oscillator - MAD

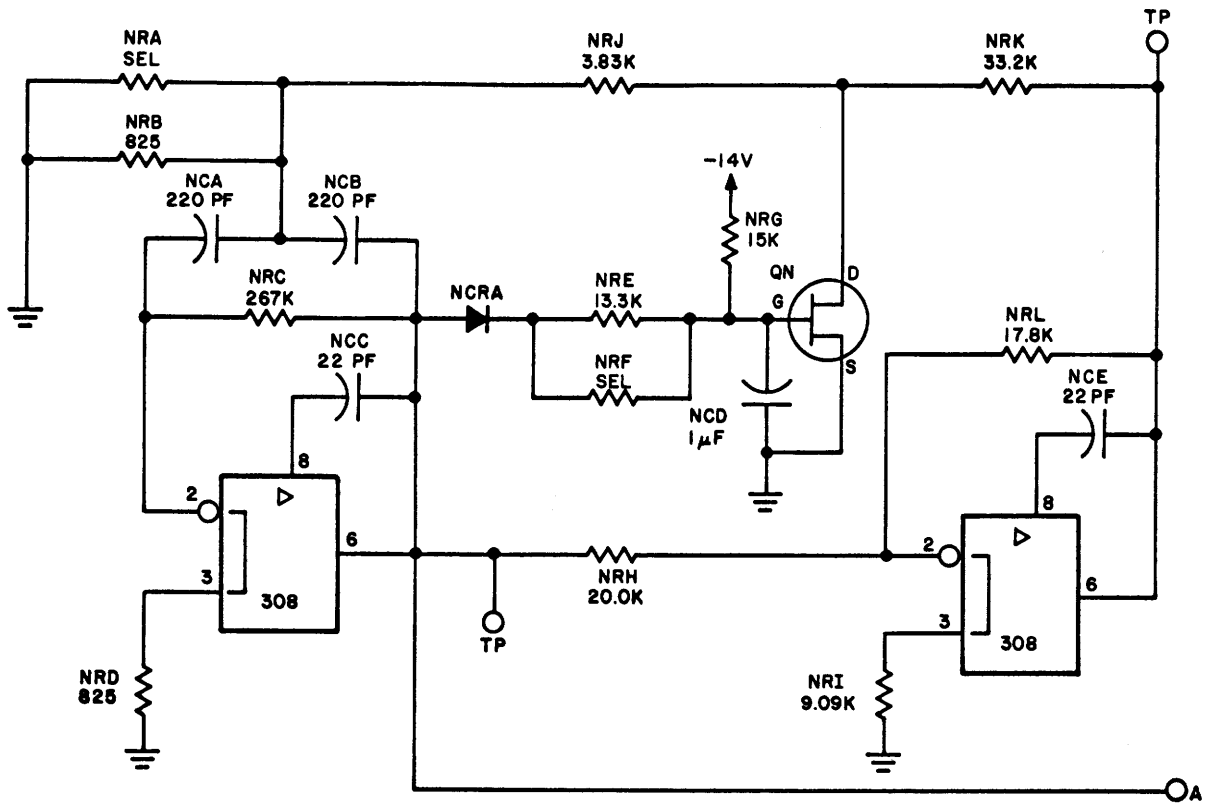
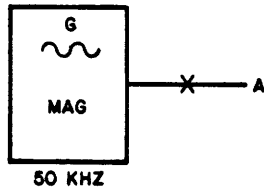

NOTE: VOLTAGE AND COMPONENT VALUES FOR REFERENCE ONLY.

7K39

Figure 7-28.1. Oscillator - MAG

Ringling Amplifier - MBC

The MBC circuit (Figure 7-29) is a tuned amplifier which is rung by the negative clock and data pulses present at input A.

The tank circuit connected to the collector of QN is tuned (and is adjustable) to twice the frequency of the input data pulses (each data pulse falls between two clock pulses; absence of a data pulse is interpreted as a zero). The high Q of the circuit affords a flywheel effect and yields a sinusoidal signal that is almost totally free of peak shift.

Transistors QP and QR form a zero-crossing detector, emitter follower circuit that provides high impedance so as not to distort the sine wave. The circuit clips the positive half of each sinusoidal excursion so that the signal at the TP is a half-wave rectified sine wave.

The transistor in the output load (next circuit) functions to clamp this rectified signal and to provide what is nearly a square wave output at B.

Quantizing Detector - QCA

Inputs A and B of the QCA circuit (Figure 7-30) are connected to the outputs of a sector transducer preamplifier. Each time a sector is detected by the transducer, a 55- μ sec "1" (+3v) pulse appears at output C. The input at A and B is an analog signal. The output at C is a standard logic signal.

With a 0-volt differential input across A and B, diode CRNA holds transistor QP off, while transistor QN is on. The collector of QP is at about +19v. Transistor QR is, therefore, off. The base-emitter junction of QS is reversed biased through resistor RNJ. Transistor QS is off. Transistor QT is turned on by the forward bias supplied through resistor RNQ and diode CRND. With QT on, diode CRNF is forward biased and conducts current from output C through QT to ground. The output is near ground, or a "0".

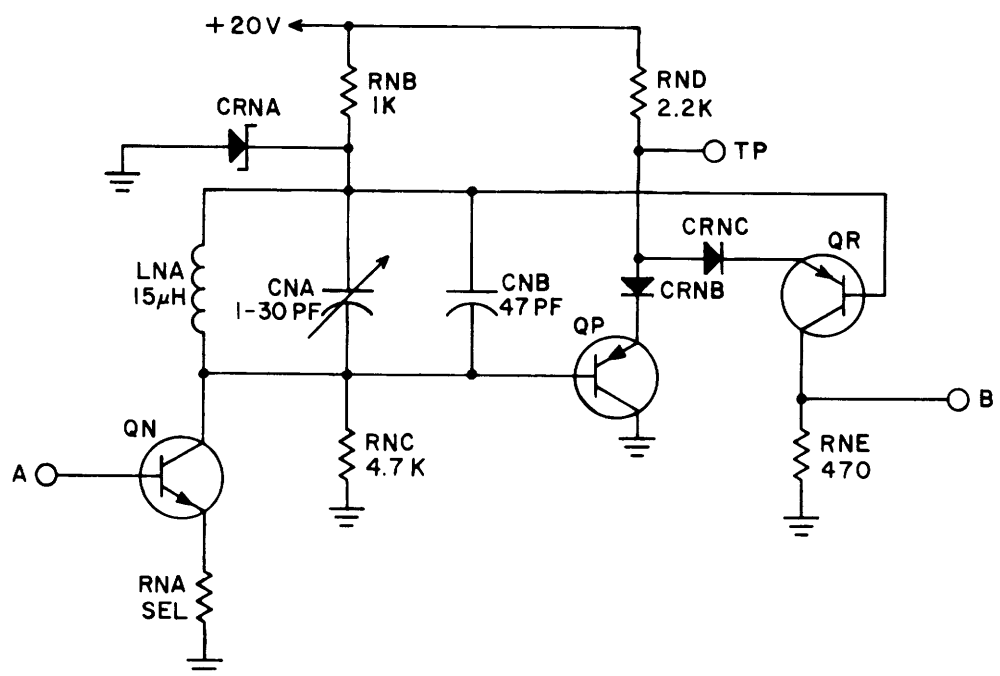
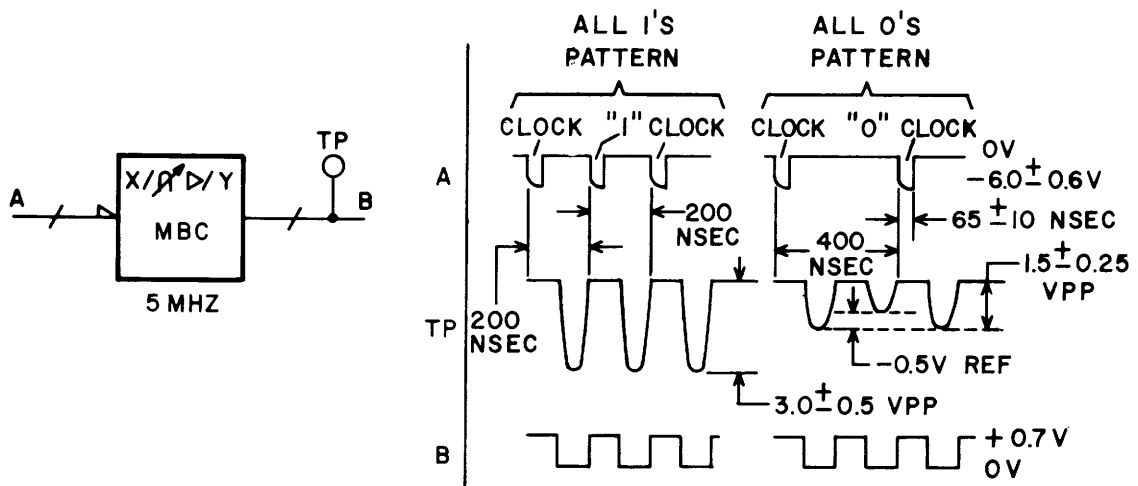

NOTE: VOLTAGE AND COMPONENT VALUES ARE FOR REFERENCE ONLY.

8T109

Figure 7-29. Ringing Amplifier - MBC

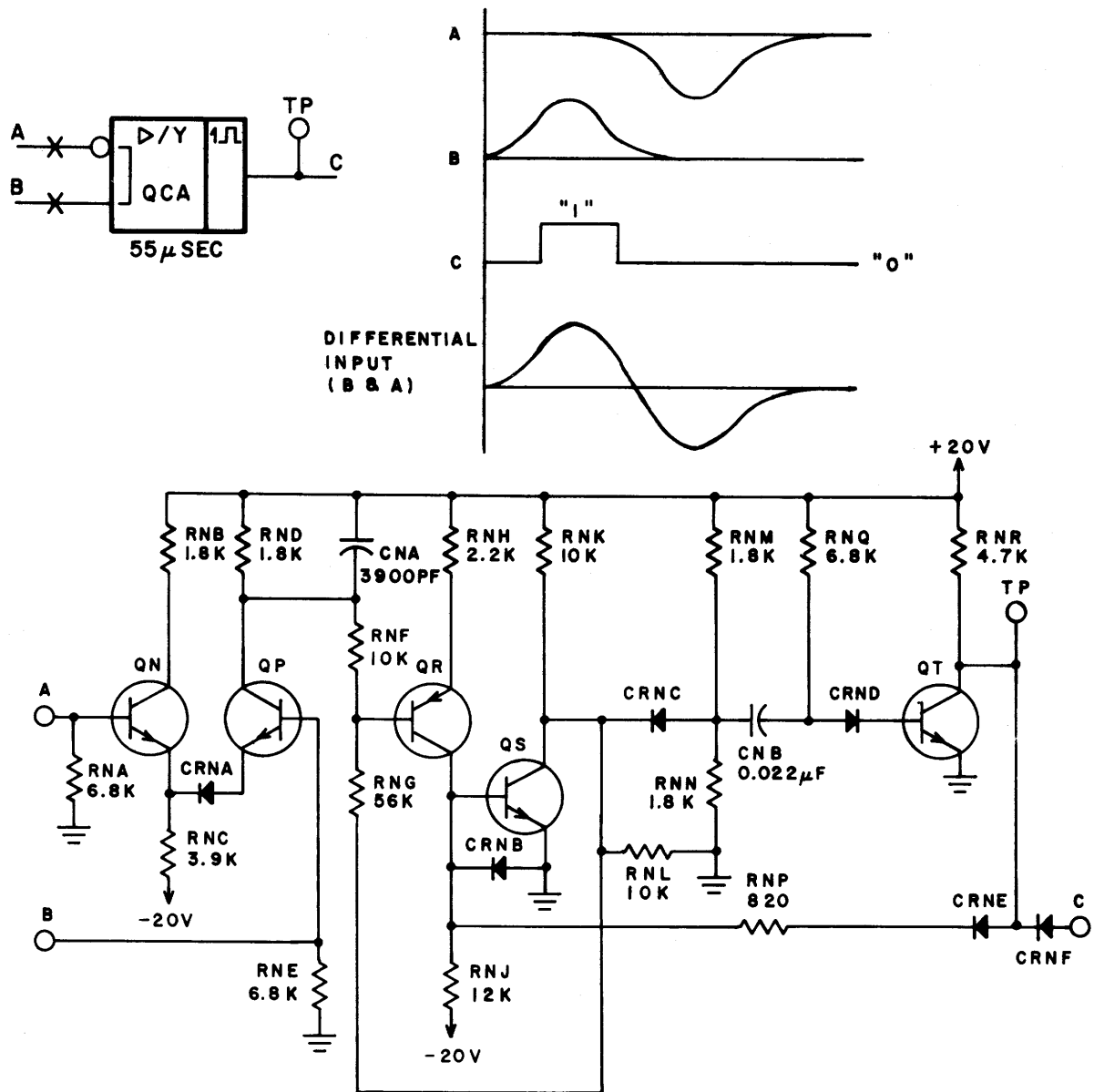

NOTE: VOLTAGE AND COMPONENT VALUES ARE FOR REFERENCE ONLY.

6T110

Figure 7-30. Quantizing Detector - QCA

When a sector mark appears, the differential voltage across inputs A and B rises with B more positive than A. Transistor QP turns on and its collector voltage falls to about +11v. The drop in voltage is felt at the base of QR. Transistor QR turns on, raising the voltage on the base of QS. Transistor QS turns on. Transistors QS and QT comprise a single shot circuit whose pulse width is determined by resistor RNQ and capacitor CNB. Transistor QT turns off, reverse biasing diode CRNF. Output C rises to a "1" level. After 55 μ sec, CNB charges sufficiently to turn on transistor QT. Diode CRNF is again forward biased and the output returns to a "0". Resistor RNP provides feedback to keep QS on while QT is off.

Speed Detector - QDB

The QDB circuit (Figure 7-31) monitors sector pulses to determine whether the spindle is at a predetermined speed. If the spindle is below speed, no output is present. When the spindle reaches the desired speed (pulse rate of more than about 33 hertz), an output current activates the speed relay which signals the controller that the unit is up to speed.

Each time a sector is sensed, a short "1" pulse is applied at input A. Transistor QN conducts and completely discharges capacitor CNA through RND to ground. When the pulse is removed, CNA charges through RNC. When the base of QP reaches the voltage at the base of QR, QP and QQ turn off. Transistor QR conducts current to silicon controlled rectifier CRM, turning it on. CRM draws current from the base of QS driving it to ground, and from the base of QR through RNK. The base of QR falls to about 9.03 volts. QR then turns on firmly and prevents "runt spikes" on the signal to CRM. Once CRM is turned on, CNB begins discharging through RNM and CRM. CRM remains on until the discharge current from CNB falls below the holding current of CRM (typically 1 ma). With the base of QS near ground, QS conducts. Transistor QT turns off, QU is on, and QV is off. No output signal is felt at B.

If the spindle is below speed, pulses arrive at the input at a low repetition rate. CNA repeatedly discharges and recharges to the point where QP and QQ are turned off. The output of QR is a series of positive pulses with a pulse width determined by $T = T_1 - T_C$ where T_1 is the time between input pulses and T_C is the time for CNA to change to the point where QP is turned off. The pulses repeatedly trigger CRM. CRM holds the voltage at the base of QS below the point where QS can turn off. Since QS is constantly on, QV is constantly off. No output is felt at B.

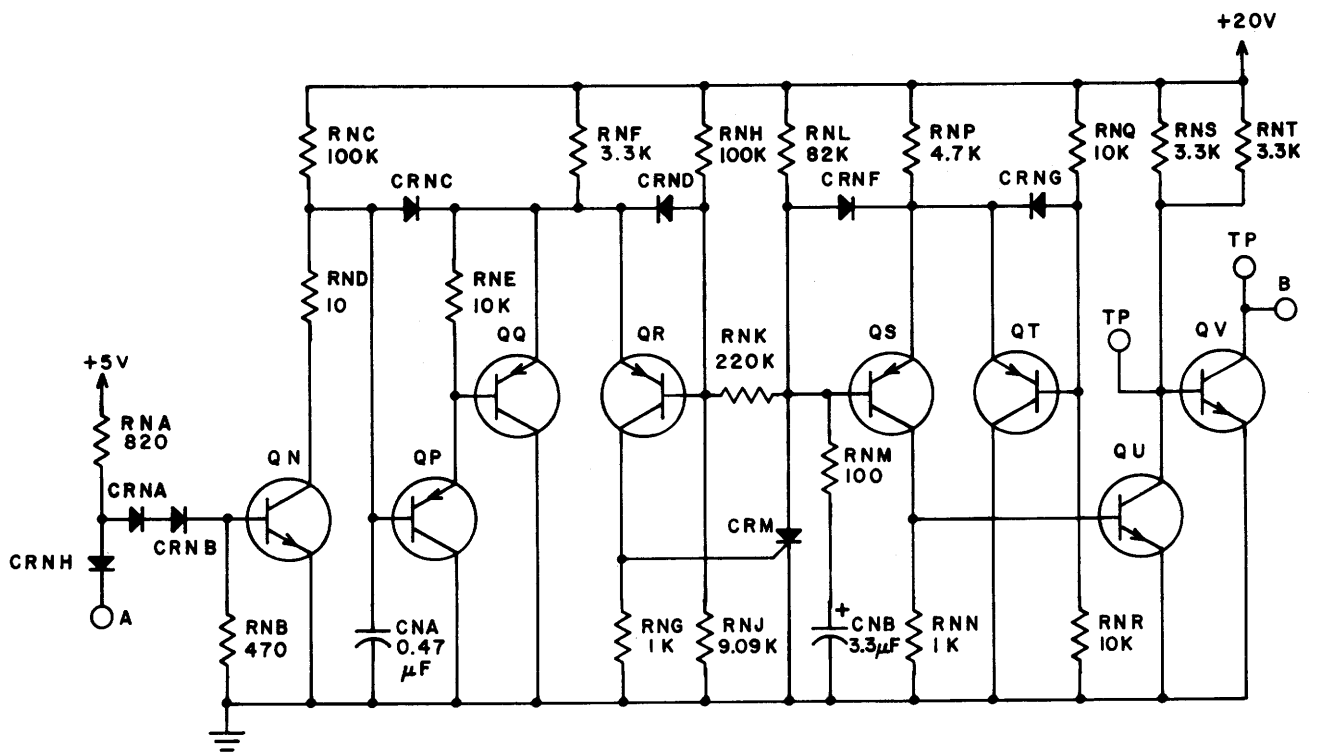
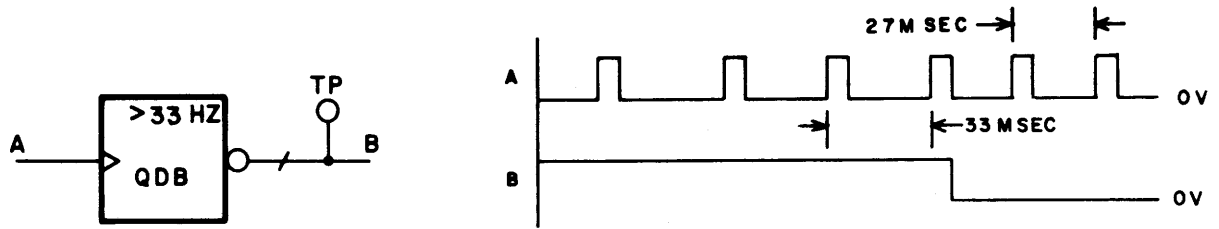

NOTE: VOLTAGE AND COMPONENT VALUES ARE FOR REFERENCE ONLY.

6T146A

Figure 7-31. Speed Detector - QDB

When the spindle reaches the required speed, the pulses at input A have the same period as T_C . The pulse width out of QR becomes $T_1 - T_C = 0$. Transistor QR never emits a pulse. With no pulses out of QR, CRM never turns on. This permits CNB to charge to the point where QS is constantly off. The higher voltage at the base of QS is fed back to the base of QR through RNK to raise the voltage required across CNA to turn off QP. This feedback prevents rapid fluctuation of the output when the spindle is near the required speed. With QS constantly off, QU is off and QV is on. Current flowing through QV activates the speed relay connected to B, and signals the controller that the unit is up to speed.

Voltage Checker - QEB

The QEB circuit (Figure 7-32) detects any decrease in voltage supply greater than a specified percentage. A fault condition will occur if:

1. -20 supply decreases below -18v
2. +20 supply decreases below +18v
3. +40v supply decreases below +36v
4. -36v supply decreases below -28.8v
5. +36v supply decreases below +28.8v
6. -5v supply decreases below -4.75v
7. +5v supply decreases below +4.75v

If all positive supplies are normal, QR, QS, QT and QU are off. Their emitters are held at +6.2v by Zener diode RVR1 and the value of RR9 (determined by testing to give a precise collector voltage). Current is pulled through QZ, causing a voltage drop across resistor RR13. This voltage drop turns QL on. Transistor QM turns off. If any of the voltage supplies drop below the specified percentage of their operating values, the respective transistor turns on. Transistor QZ will then be off. Transistor QL turns off. Transistor QM turns on, driving the output to ground.

The negative voltage segment of the circuit is similar to the positive section. A decrease in the -20v supply below -18v will turn QP on. Transistor QV turns off, causing QW to turn off. Transistor QX turns on causing a voltage drop across NR14 which turns QY on. The output drops to ground.

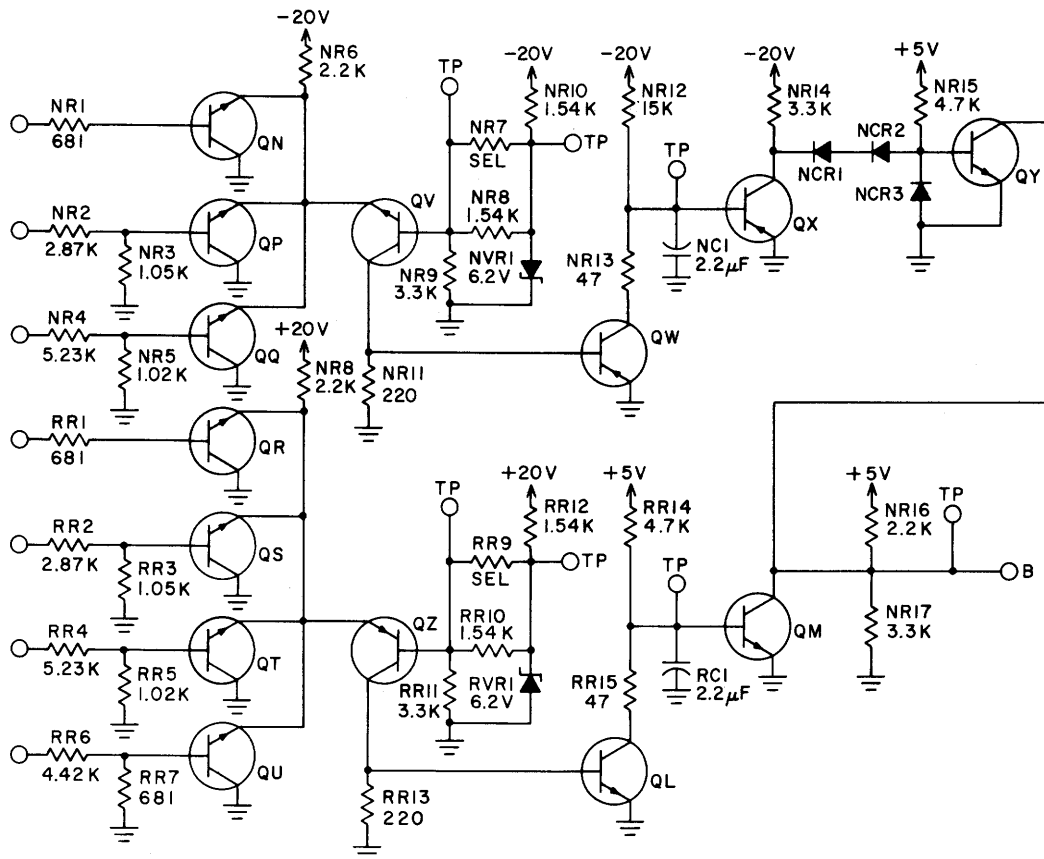
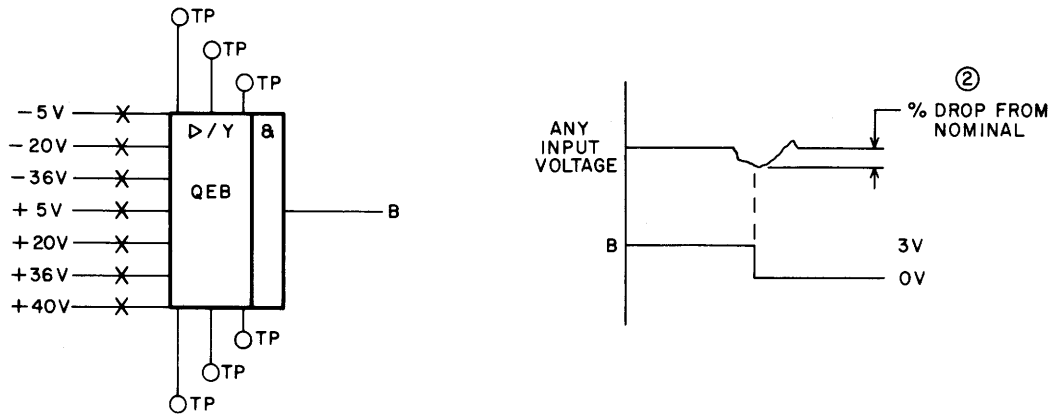

NOTES:

- 1. VOLTAGE AND COMPONENT VALUES ARE FOR REFERENCE ONLY.
- ② 5% DECREASE FROM NOMINAL $\pm 5V$, 10% DECREASE FROM NOMINAL $\pm 20V$ OR $\pm 40V$, OR 20% DECREASE FROM NOMINAL $\pm 36V$.

6T143

Figure 7-32. Voltage Checker - QEB

Quantizing Detector - QFA

The QFA circuit (Figure 7-33) detects a fault in the write and erase drivers or in the head select circuit. If there is an open in the head, either of the drivers is non-functional, or more than one head is selected, a fault signal occurs.

Inputs A and B are connected to the write and erase driver circuits and enter across a voltage bridge to the base of QP. Normally, both inputs are approximately 32v. All diodes are forward biased. Voltage on the base of QP is 32v and the emitter is at 31.4v due to a reverse bias 0.6v base-emitter voltage across QP. Transistor QP is off. All input current goes to ground through RND.

If input A is higher than input B by 1.4v, CRNB and CRNC are forward biased. CRNA and CRND are reverse biased. The voltage on the base of QP becomes that of input B. The emitter of QP is 0.7v higher than the base due to a 0.7v drop across CRNB. Transistor QP is on.

If input B is higher than input A by 1.4v, CRNA and CRND are forward biased. CRNB and CRNC are reverse biased. The base of QP is at the voltage of input A. The emitter of QP is 0.7v higher than the base. Transistor QP is on.

Input C is connected to the head select circuits. If more than one head is selected, the drop in effective resistance (due to external resistors in parallel) results in an increase in current through RNA. This increases the voltage drop across RNA, turning QN on.

If either QN or QP is on, QR turns on. Output D goes to ground to signify a fault condition.

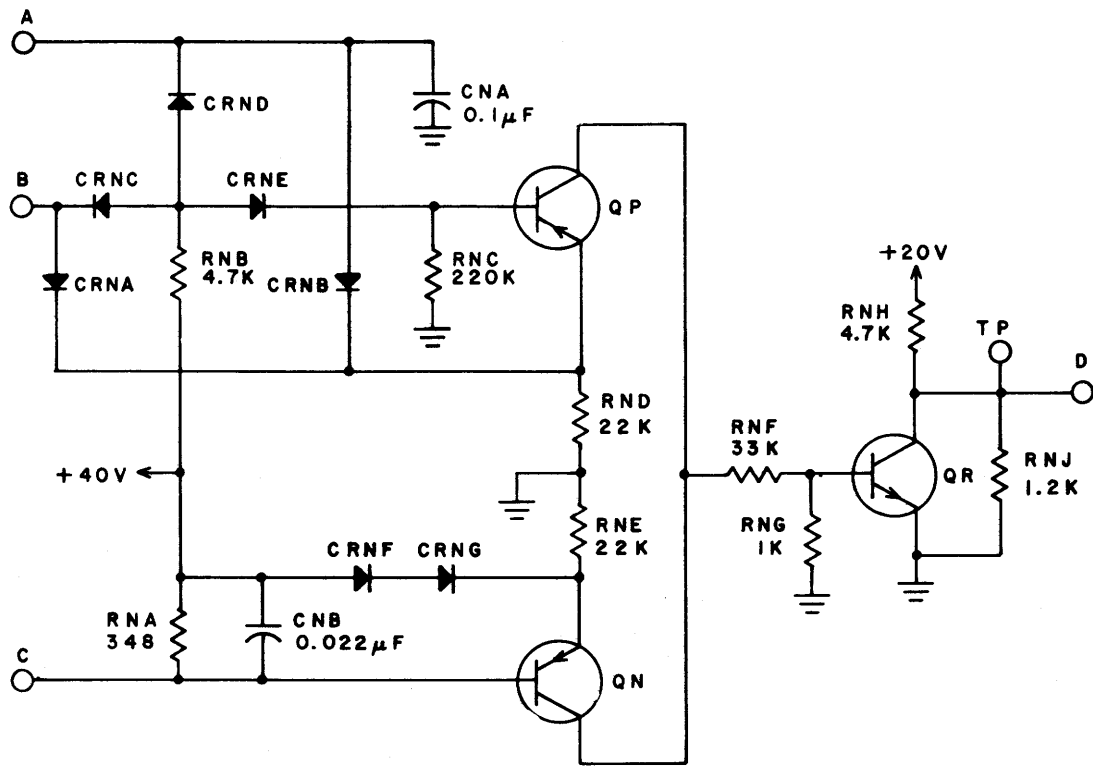
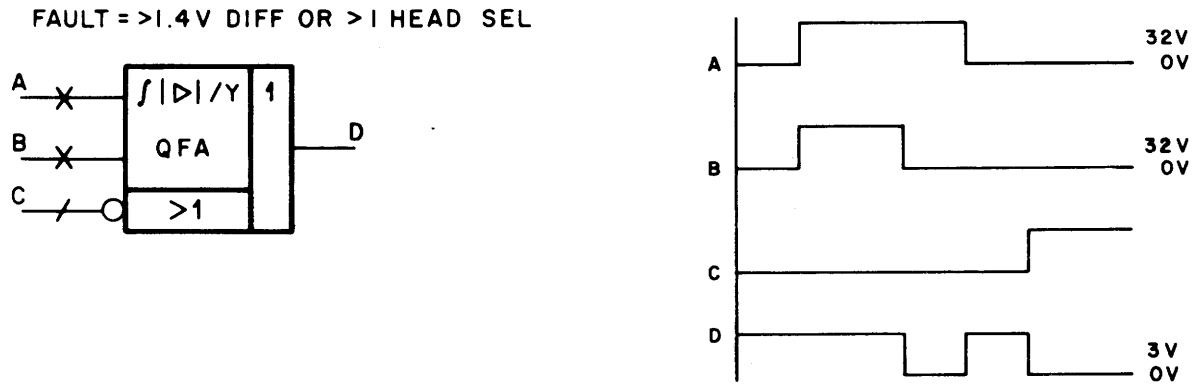

NOTE: VOLTAGE AND COMPONENT VALUES ARE FOR REFERENCE ONLY.

6T111

Figure 7-33. Quantizing Detector - QFA

Quantizing Detector - QFB

The QFB circuit (Figure 7-34) is used to amplify and shape an incoming wave. The input at A and B is a differential sine wave. The output at C and D is an amplified and clipped version of the input wave.

Transistor QR is the current source for the differential amplifier stage consisting of QN and QP. Capacitors CNA and CNB filter out dc and low frequency noise and pass the input wave which alternately turns on QN and QP. The output at the collectors of QN and QP are clipped by diodes CRNA and CRNB to approximate a square wave. This square wave is fed to the bases of QS and QT for another stage of differential amplification. The square wave output at the collectors of QS and QT is again clipped by diodes CRNC and CRND. The output at C and D is a clipped, square wave between 0v and +0.6v corresponding to the rise and fall of the sine wave at inputs A and B, respectively.

Single Shot - QFF

The QFF circuit (Figure 7-35) produces a positive pulse output in response to a positive input pulse. The width of the output pulse is independent of the input and is adjustable.

Assume a condition where QN is on. With the collector of QN at ground, QP turns off and CNC begins charging (through RNL to ground via QN and QS) toward vcc volts. The duration of the charging period is controlled by the time constant $RNL \times CNC$. When the base of QQ reaches 0.7 volts, QQ turns on, QS turns off, and the output goes to ground.

With the circuit in the condition of the preceding paragraph, a no-signal state will have the following effect: Ground level at base of QN turns it off. Since QS is also off, current is drawn through the base of QP and turns it on. Current now flows through QP charging CNC in the opposite direction (from preceding paragraph) to about -5.3 volts (Zener diode CRNC voltage minus the 0.7 base-emitter voltage of QQ). As the current increases and decreases (during charging period) through QP, the remaining current still flows through RNL thereby keeping QQ on.

When a clock or data pulse is applied to the base of QN it turns on. With the QN collector at ground, QP turns off and a -5.3 base-emitter voltage appears across QQ. Capacitor CNC again charges through the variable resistor RNL until QQ turns on.

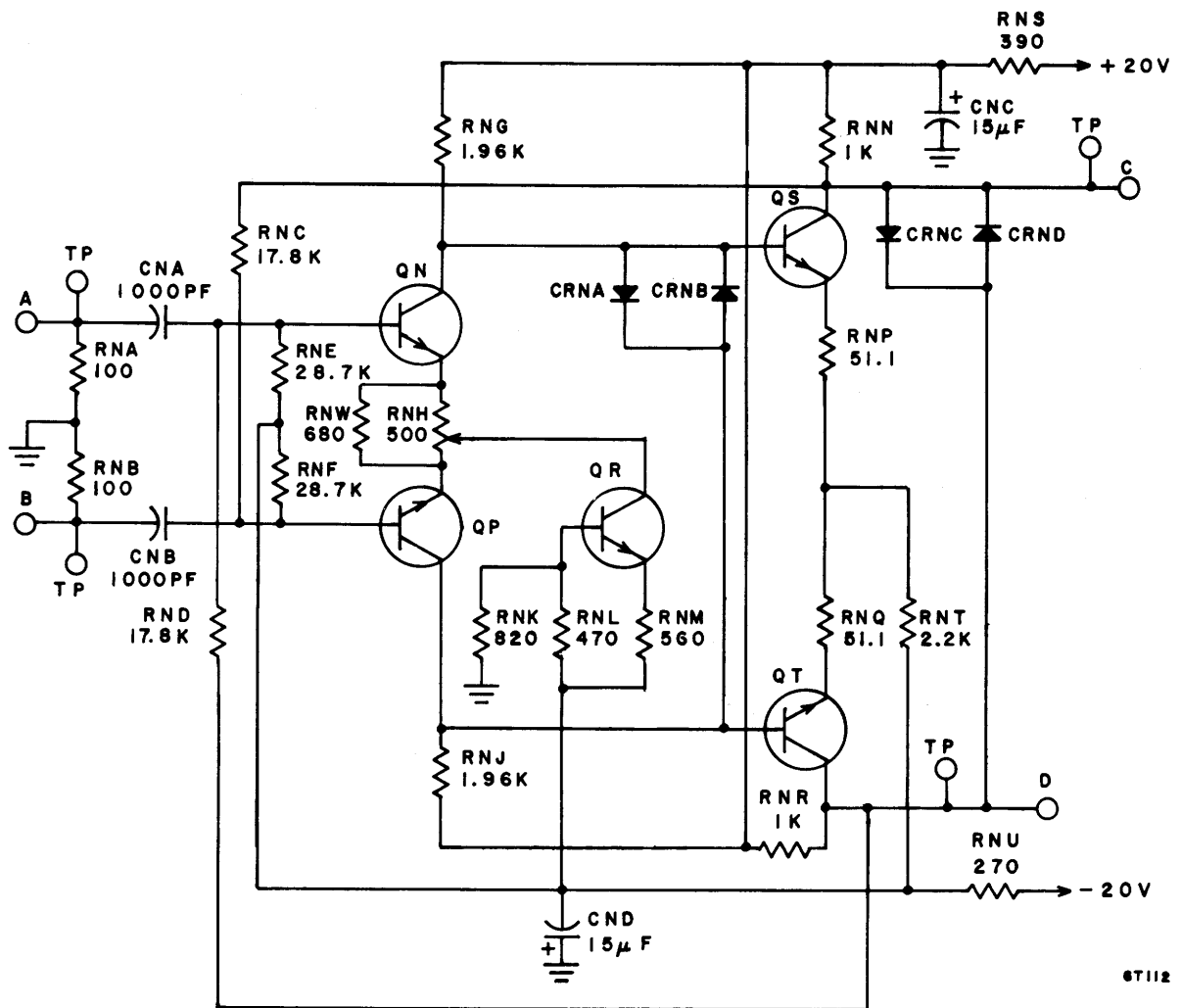
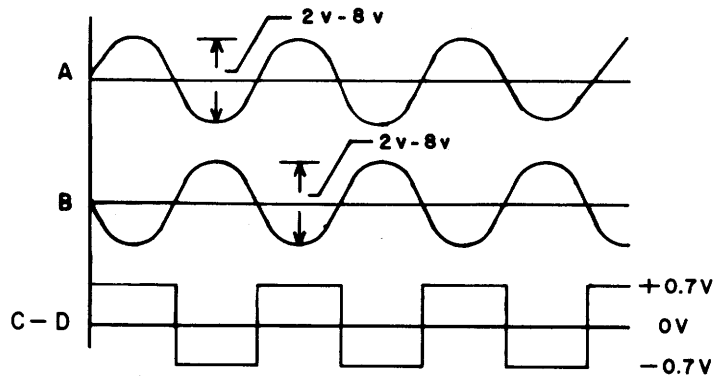
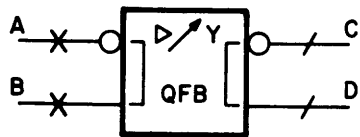

NOTE: VOLTAGE AND COMPONENT VALUES ARE FOR REFERENCE ONLY.

Figure 7-34. Quantizing Detector - QFB

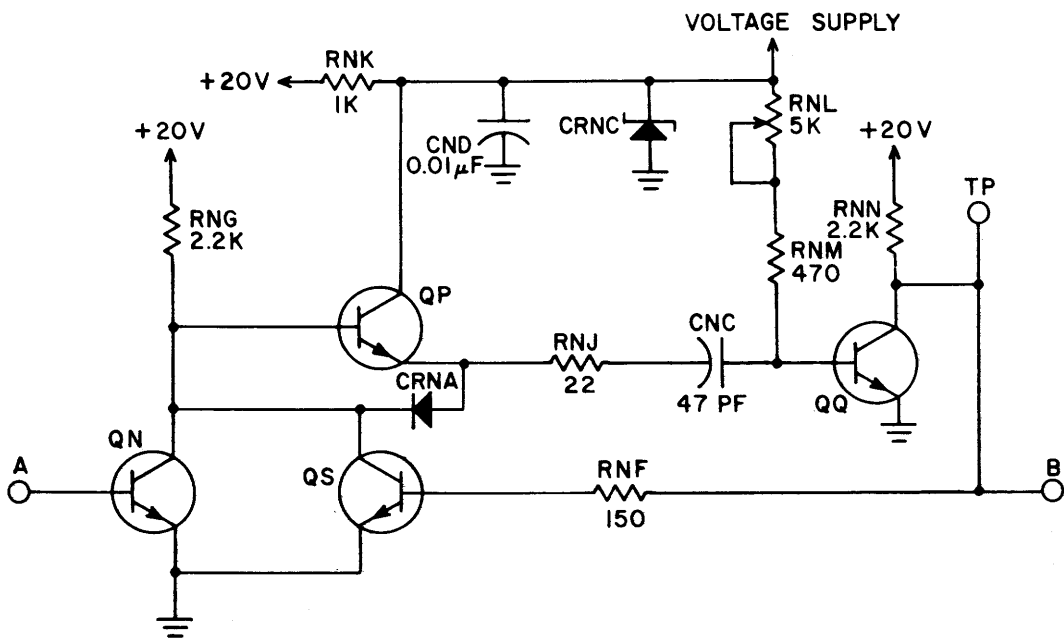
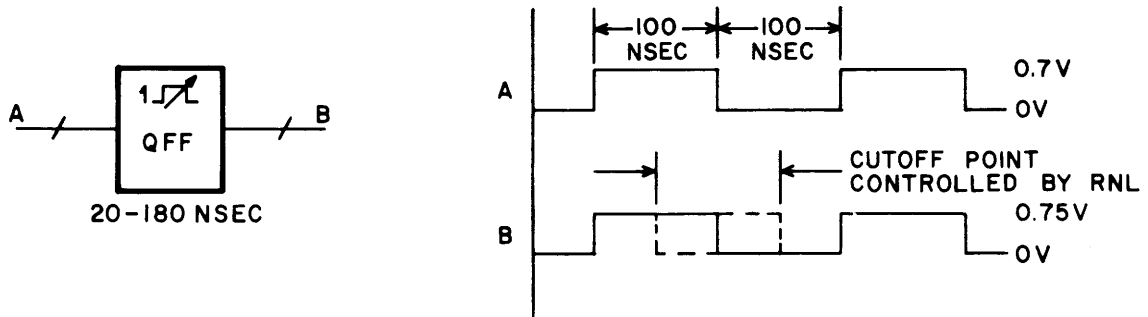

NOTE: VOLTAGE AND COMPONENT VALUES ARE FOR REFERENCE ONLY.

6T113

Figure 7-35. Single Shot - QFF

When the circuit has been adjusted so that the width of the output pulse exceeds that of the input pulse, QS stays on (after the input drops) to hold the base of QP at ground.

Whenever CNC is charging through RNL with current flowing through RNN, QN and QS are on to conduct the increase current.

Capacitor CND is a filter capacitor to provide a constant voltage across CRNC.

Function Generator - QGD

The QGD circuit (Figure 7-36) is a non linear feedback network used as the gain determining element for an operational amplifier.

With a 10K input resistor, an amplifier with the QGD circuit will exhibit high gain characteristics for amplifier output voltages of less than ± 2 volts. A gain of unity is achieved at output voltages ± 5 volts with this gain persisting at higher voltages.

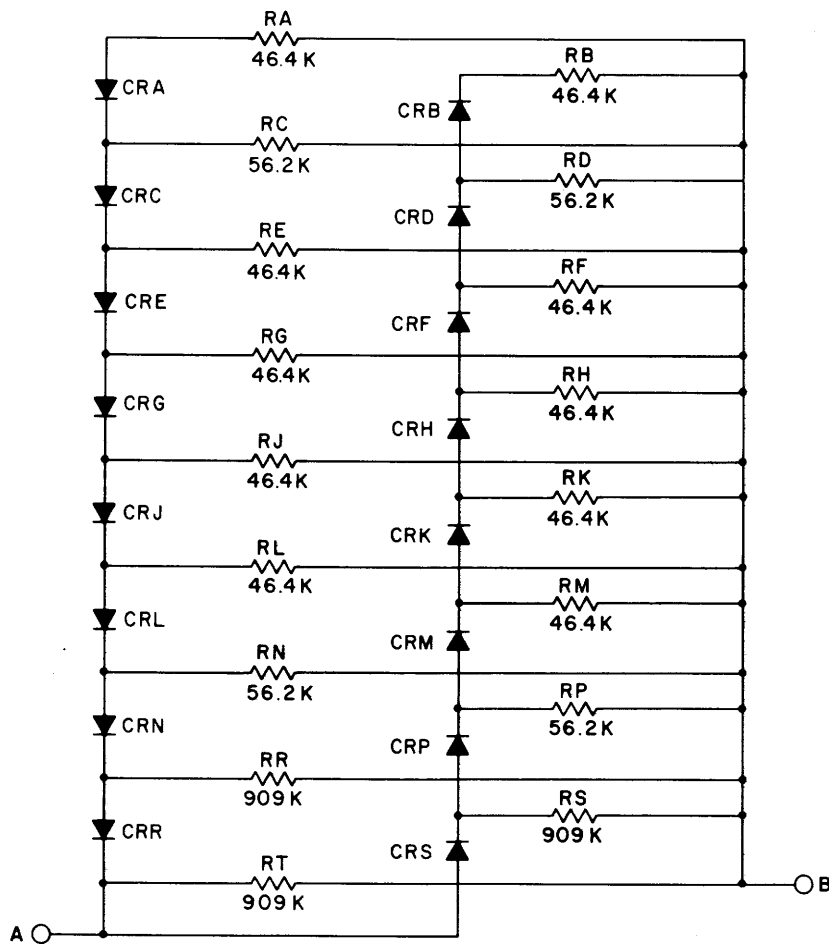
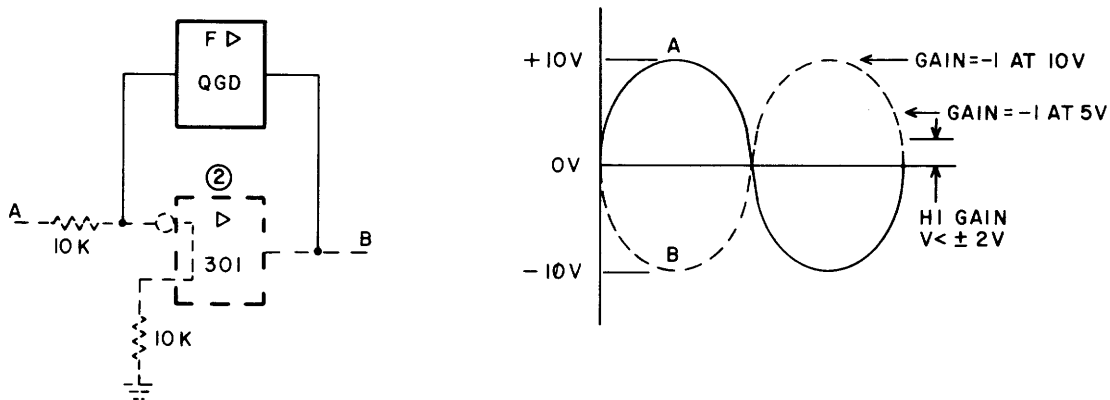

NOTES: 1. VOLTAGE AND COMPONENT VALUES ARE FOR REFERENCE ONLY.
 ② SHOWN FOR REFERENCE ONLY.

6T139

Figure 7-36. Function Generator - QGD

Line Receiver - RAB

The line receiver circuit, RAB, (Figure 7-37) provides a "1" output at C when the difference in input voltage (A minus B) is greater than +0.6v. Under any other input conditions, the output will be a "0".

Diode NCR1 is used to maintain the threshold level at +0.6v. Without NCR1, the threshold would be about +0.1v. That is, if input B were just 0.1v less positive than input A, the circuit would switch to an output of "1".

Resistor NR5 supplies the emitters of QN and QP with a constant current of about 4.25 ma. If the current in one transistor increases, the current in the other transistor must decrease by an equal amount. If input B is more positive than input A (A minus B is negative), QP will be turned on and QN will be turned off. If the difference A minus B is only slightly negative, QP will conduct more than QN, but both will be on.

The base of QR, therefore, becomes more negative than the base of QQ. Transistor QR turns on, driving its collector and the base of QS positive. Transistor QS turns on, conducting current from the +20v supply through NR13 to ground. The output at C is near 0v or a "0".

If input A is at least +0.6v more positive than input B (A minus B is greater than or equal to +0.6v), QN turns on and QP turns off. The base of QQ is then more negative than the base of QR. Transistor QQ turns on, conducting current from the +20v supply, through NR10 to ground. Transistor QS is turned off as there is no current to its base. Current is then allowed to flow from the +20v supply, through the load resistors to output C. The value of the output voltage is approximately +3.5 volts or a "1".



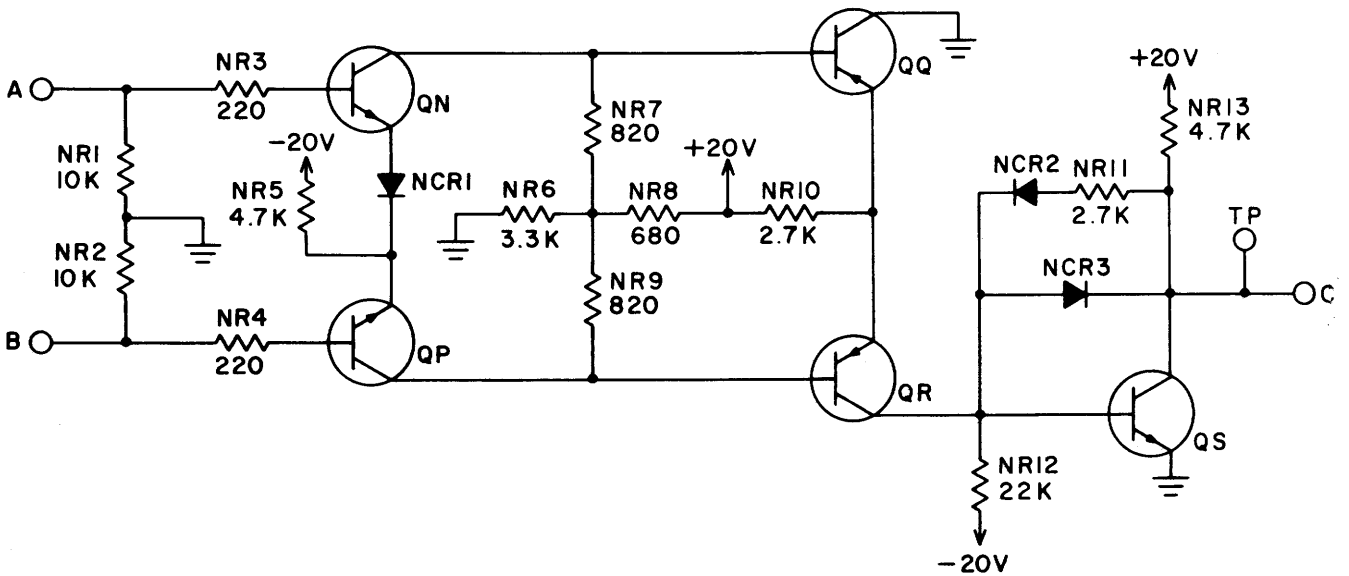
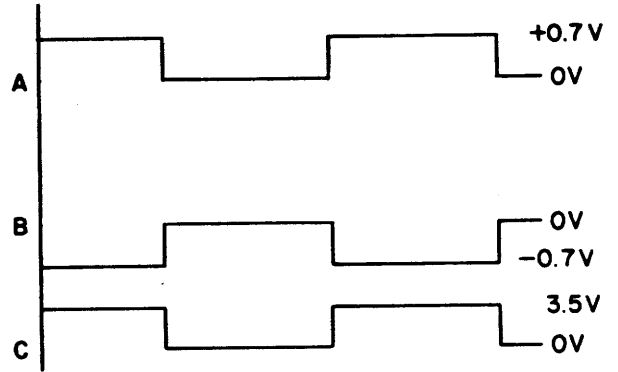
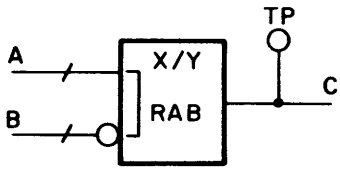

NOTE: VOLTAGE AND COMPONENT VALUES ARE FOR REFERENCE ONLY.

6T144A

Figure 7-37. Line Receiver - RAB

Switch Receiver - RCB

Switch Receiver RCB (Figure 7-38) produces a "1" (+3v) output at B when the grounded switch connected to input A is closed. When the switch is open a "0" (0v) is felt at output B.

A switch to ground is connected to input A. When this switch is open, capacitor NC1 approaches +5v and QN is shut off. Transistor QP is, therefore, on and conducts current to the base of QQ through resistor NR6. Transistor QQ turns on, conducting current away from output B, and drops the output to near ground or a "0".

When the switch is closed, the voltage across NC1 rapidly increases through NR1 and the switch to ground because of the short time constant of NR1 and NC1. Any contact bounce on the switch will increase the discharge time. As the voltage across NC1 decreases, QN begins to turn on. As QN conducts current to the base of QP, the forward bias on QP is decreased and QP begins to turn off. As QP turns off, the current through NR5 decreases due to the higher lead resistance (NR4) of QN compared with QP (NR6). The current drop through NR5 causes a decrease in the voltage drop across NR5. The bias on QN is, therefore, increased. The cycle goes rapidly to completion. Transistor QP is shut off. With QP off, the base of QQ is near ground, causing QQ to shut off. This allows the +5v supply to flow through NR8 to output B raising the output to +3v, "1".

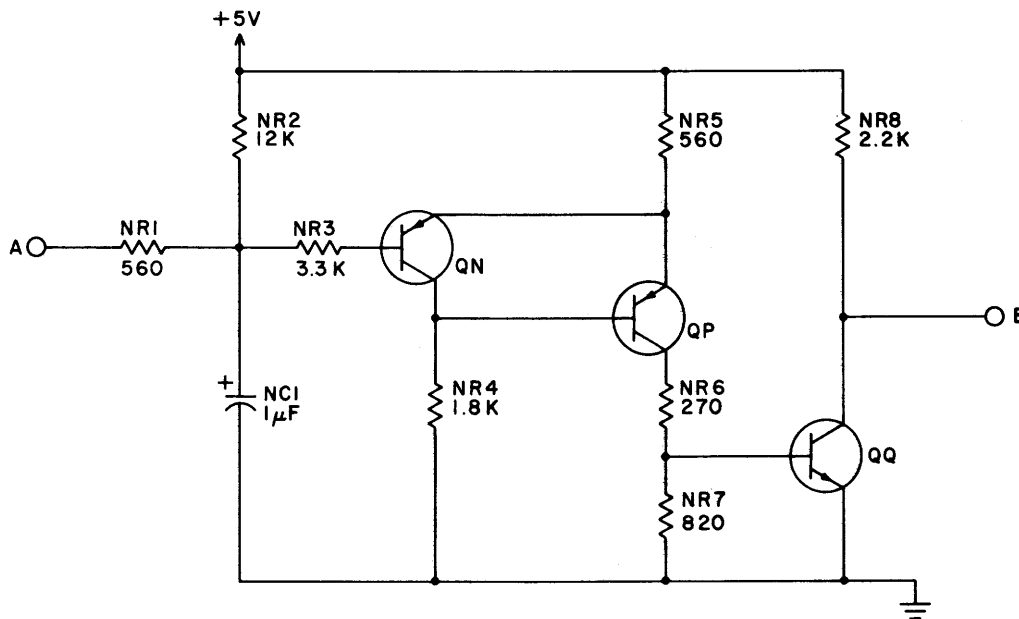
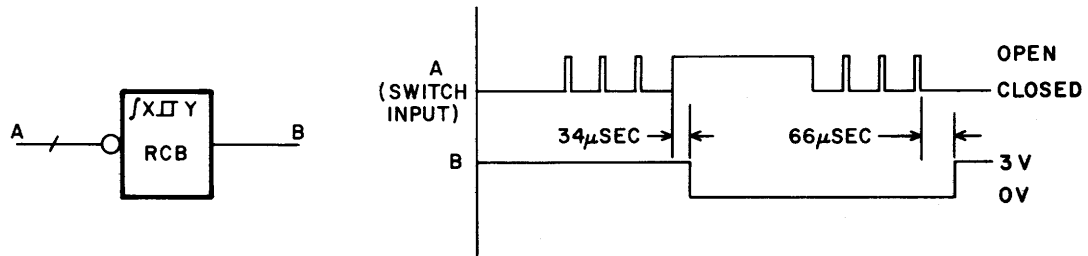

NOTE: VOLTAGE AND COMPONENT VALUES ARE FOR REFERENCE ONLY.

8T145

Figure 7-38. Switch Receiver - RCB

When the switch is opened again, NC1 charges slowly to +5v due to the long time constant of NR2 and NC1. Any contact bounce on the switch will hold NC1 well below the switching level of QN until the bouncing ceases. As the voltage across NC1 increases, QN begins to turn off. Transistor QP begins to conduct current away from the emitter of QN. Transistor QP turns on rapidly because of this positive feedback. The output then returns to "0".

Line Receiver - RFA

The RFA circuit (Figure 7-39) provides a non-standard "0" output at C when input A is at least 0.6v more negative than input B. Diode CRNA holds the threshold at 0.6v. Under all other input conditions, the output will be a non-standard "1".

If the differential input (A-B) is greater than 0.6v, transistor QP turns on and QN turns off. This drives the base of transistor QR more positive than the base of QQ. Transistor QR conducts current from the -20v supply, through RNK to ground. The output at C is near 0v.

If the differential input (A-B) is less than 0.6v, QN turns on and QP turns off. The base of QQ goes more positive than the base of QR. Transistor QQ conducts and a negative voltage is felt at output C.

Since a "1" is defined in MDD logic as the most positive voltage, the 0v output in the first case is interpreted as a non-standard level "1". The negative voltage output in the second case is, therefore, a non-standard level "0".

The receiver is self-terminated with 56 ohms to ground on each line.

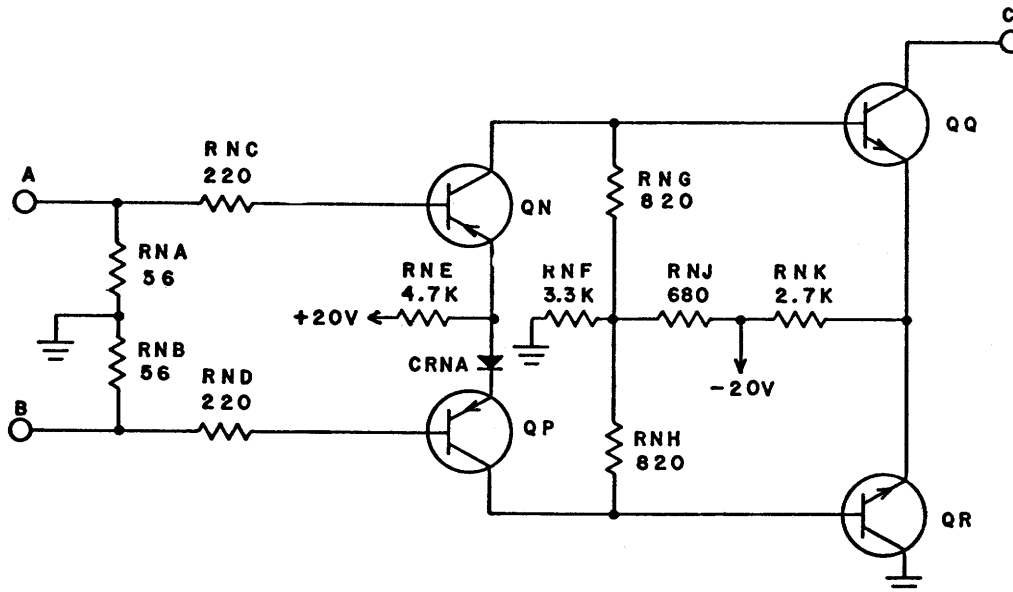
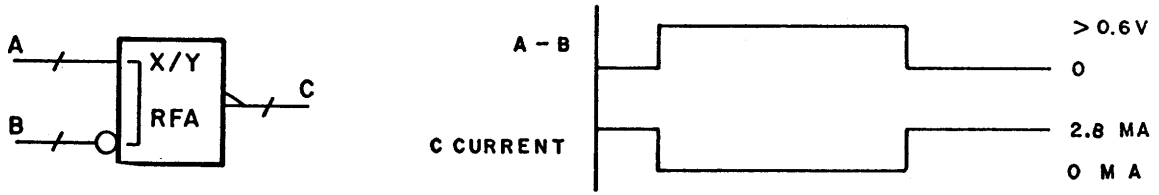

NOTE: VOLTAGE AND COMPONENT VALUES ARE FOR REFERENCE ONLY.

6T114

Figure 7-39. Line Receiver - RFA



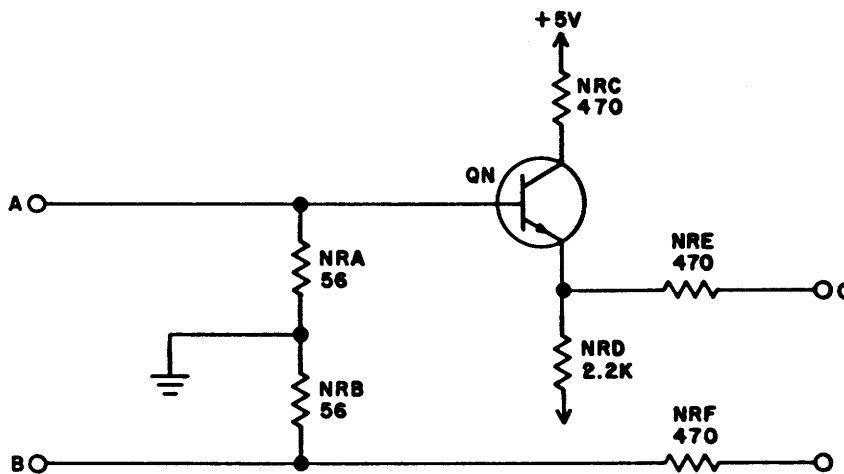
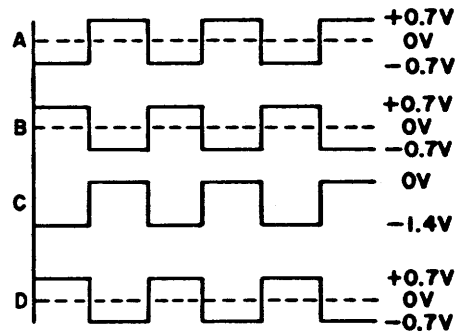
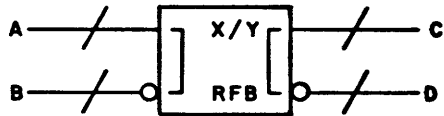

NOTE: VOLTAGE AND COMPONENT VALUES ARE FOR REFERENCE ONLY.

7K29

Figure 7-39.1. Receiver Terminator and Offset - RFB

Receiver Terminator and Offset - RFB

Resistors NRA and NRB terminate write data from twisted pair inputs A and B. The same signal appears at input A and the emitter of QN except for the V_{BE} drop of 0.7v. This 0.7v maintains a differential voltage at outputs C and D, even when the I/O Line is open or non-operative. Outputs C and D feed into a receiver that switches each time the difference signal crosses 0 vdc.

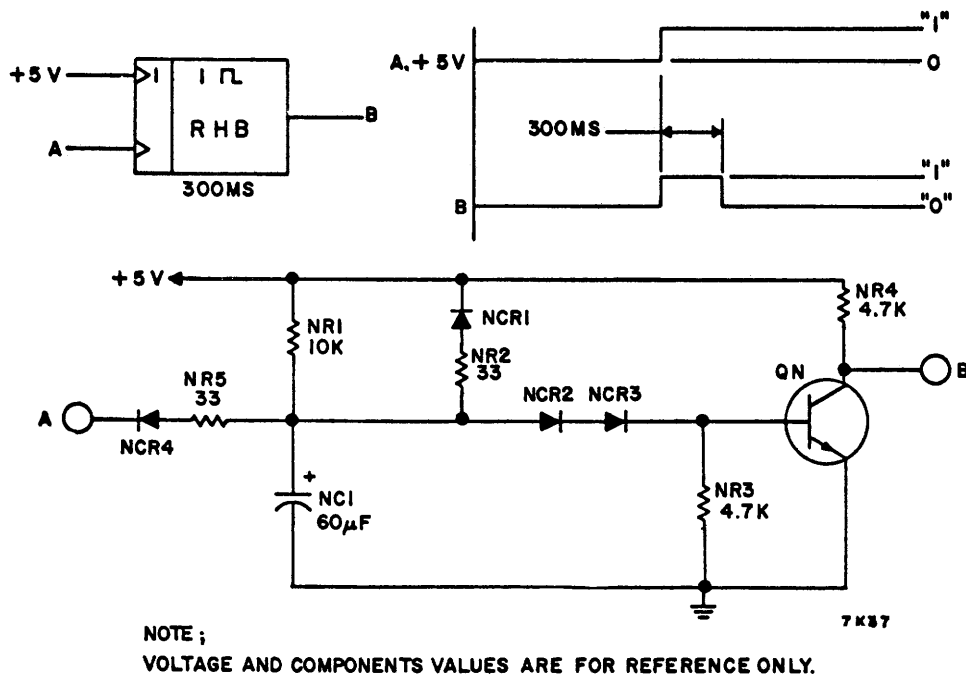

Figure 7-39. 1. Delay - RHB

Single Shot - RHB

The RHB circuit (Figure 7-39. 1) is a single shot that holds a clear signal on the units Fault register for 300 ms after +5 volts becomes available or the CLEAR FAULT switch on the logic chassis maintenance panel is pressed.

The circuit delay characteristic occurs as NC1 charges through NR1 to a threshold voltage of 2.1 vdc (determined by NCR2, NCR3, and base-emitter junction of QN). Register NR2 and diode NCR1 provide a quick discharge path for NC1 when the input drops. The presence of this path ensures a short recycle period for transient off/on application of the input.

Bipolar Current Buffer - SAA

The SAA circuit (Figure 7-40) is a power output stage for an operational amplifier. Transistors QP and QQ comprise a complementary output driver and are always biased slightly on by diodes NCR1 and NCR2.

The quiescent current in the output driver is nominally 6.5 ma and the maximum signal amplitude for the circuit is ± 5 volts.

Amplifier - SAB

The SAB circuit (Figure 7-40.1) is a non-inverting, voltage gain of 1, current amplifier. The circuit provides high current drive capability for analog sources. (Like the MAG circuit.)

Fwd EOT Clamp - SAC

The SAC Circuit (Figure 7-40.2) is a TTL level operated current sink. The circuit sinks current from the position transducer demodulator circuit to prevent erroneous FWD EOT signals from appearing.

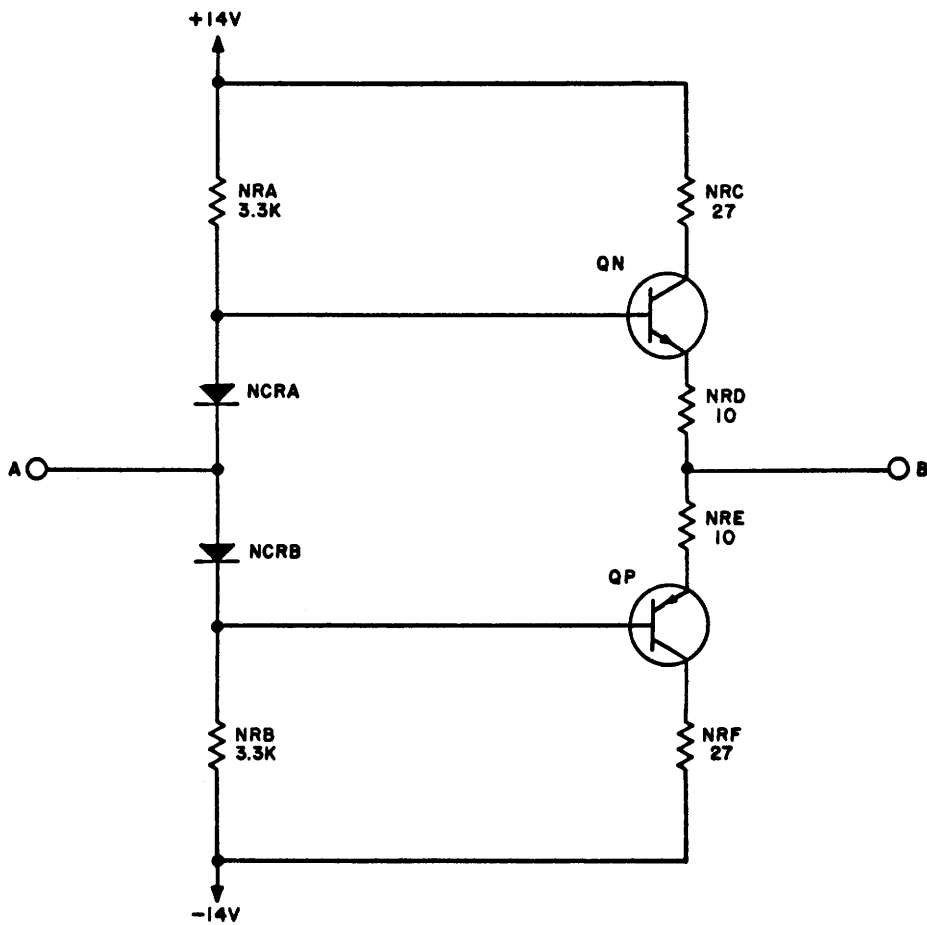
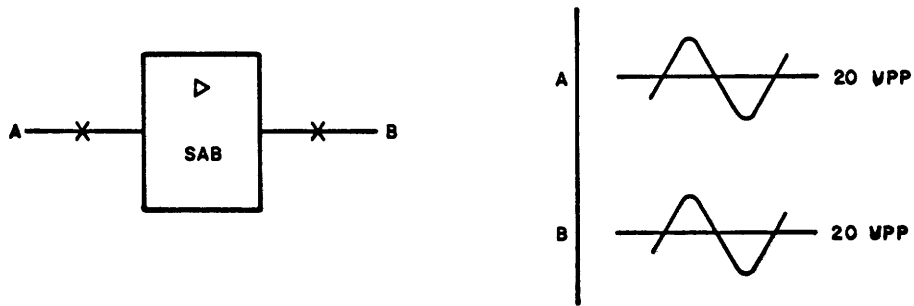

NOTE: VOLTAGE AND COMPONENT VALUES FOR REFERENCE ONLY.

7K40

Figure 7-40.1. Amplifier - SAB

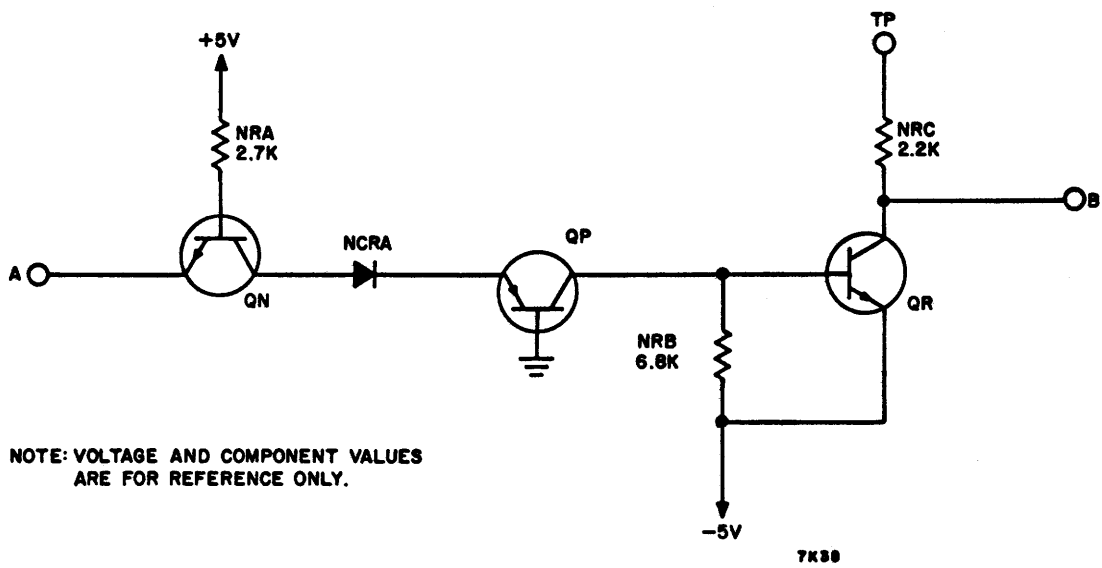
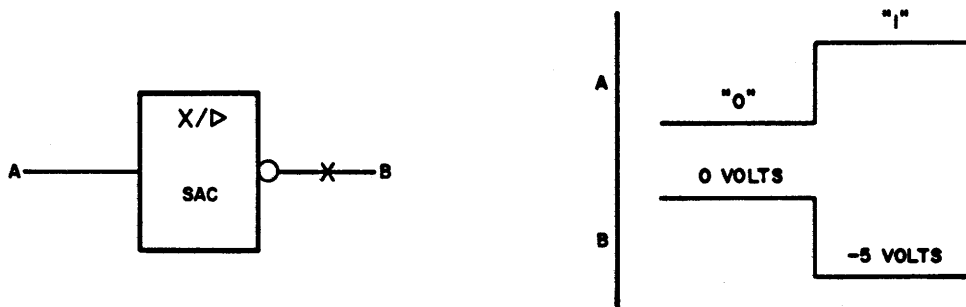

Figure 7-40.2. Fwd EOT Clamp - SAC

Demodulator - SBA

The SBA circuit (Figure 7-41) is a linear product detector operating on a fixed amplitude reference signal applied at input C and a variable amplitude information signal applied differentially across inputs A and B.

The information signal and the reference signal are transformer coupled to a matched diode bridge network by transformers NT1 and NT2, respectively. Resistors NR5, 6, 7, and 8 are selected to null out any mismatch in the bridge diodes or the other bridge resistors.

An output filter, NL1 and NC1, rejects the unwanted 50 kHz reference signal at the output of the circuit.

When the input signal across A and B is nulled, the bridge is unbiased and current flow depends on the polarity of the NT2 secondary. If the top of the winding is positive relative to the bottom, current flows from the bottom of the winding through CRNA, NR1, NR2, and CRNC back to the top of the winding. If the polarity is opposite that previously stated, current flows from the top of the winding through CRND, NR4, NR3, and CRNB returning to the bottom of the winding. In either case, output D is at 0 ± 4 mv.

When the signal at A and B becomes in phase with the reference signal at C, the bridge is biased in the positive direction. This state reduces current flow through NR2/CRNC and NR3/CRNB which unbalances the NT2 secondary halves and causes the center tap (and circuit output D) of the NT2 secondary to go positive. As the amplitude of the input signal increases, the increasing bridge bias drives the circuit output more positive.

A signal at A and B that is out of phase with reference signal C, biases the bridge in the negative direction. Now current flow through NR1/CRNA and NR4/CRND legs is reduced. Again the NT2 secondary halves are unbalanced, but in this case the center tap goes negative. As before the output amplitude increases and decreases with the amplitude of the input signal.

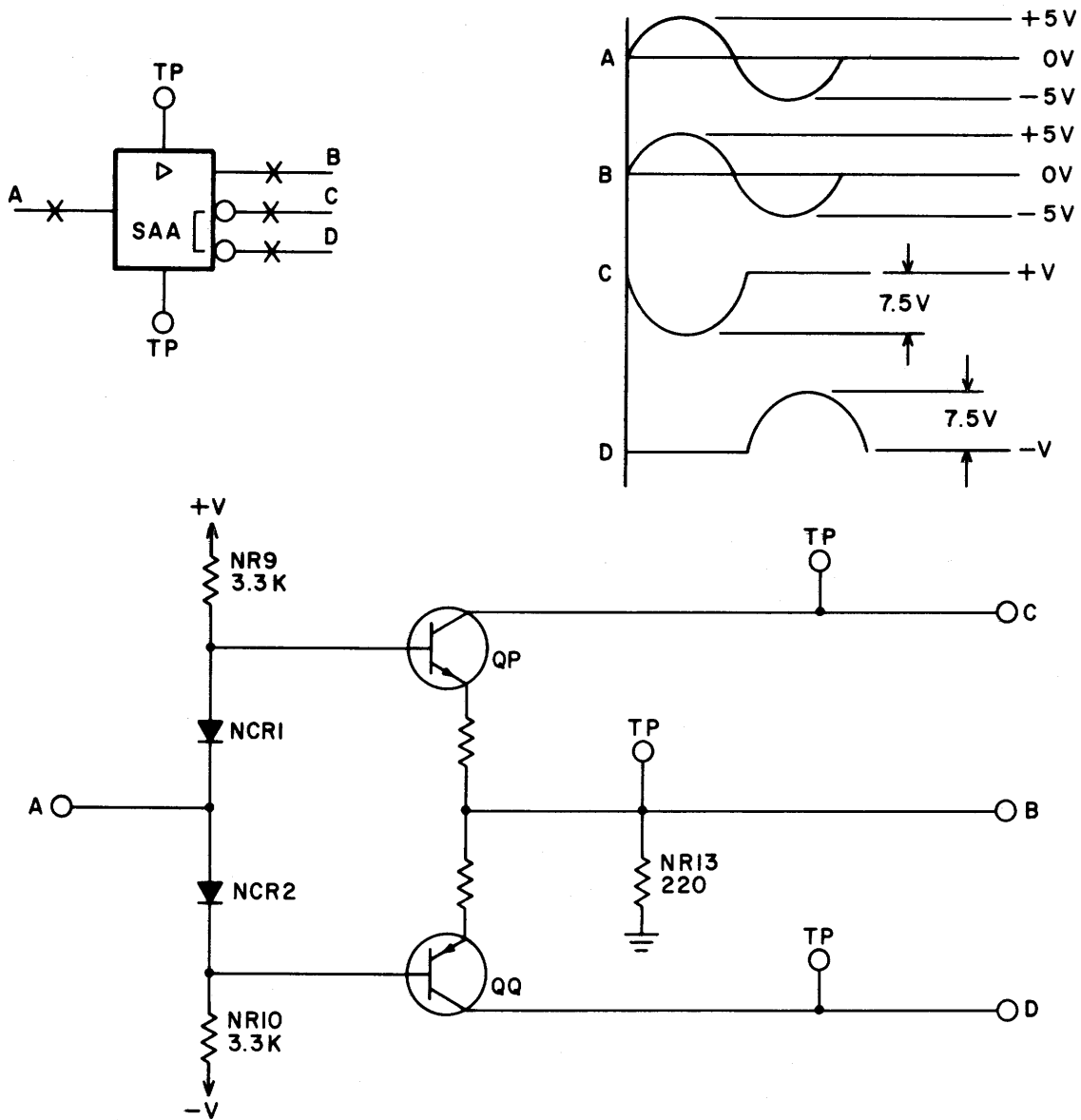

NOTE: VOLTAGE AND COMPONENT VALUES ARE FOR REFERENCE ONLY.

6T140

Figure 7-40. Bipolar Current Buffer - SAA

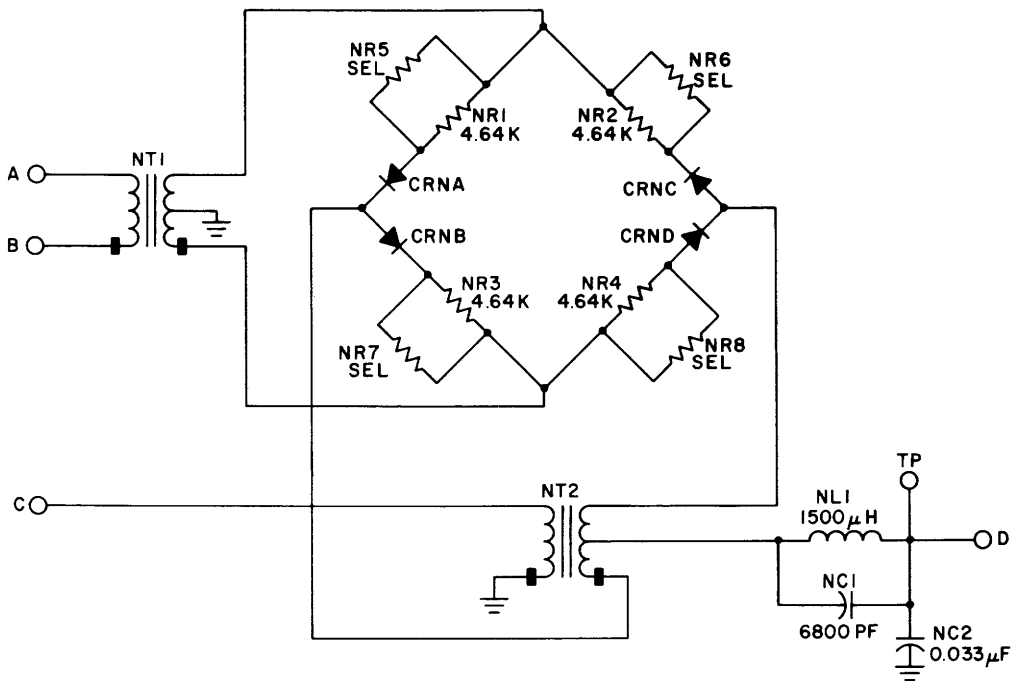
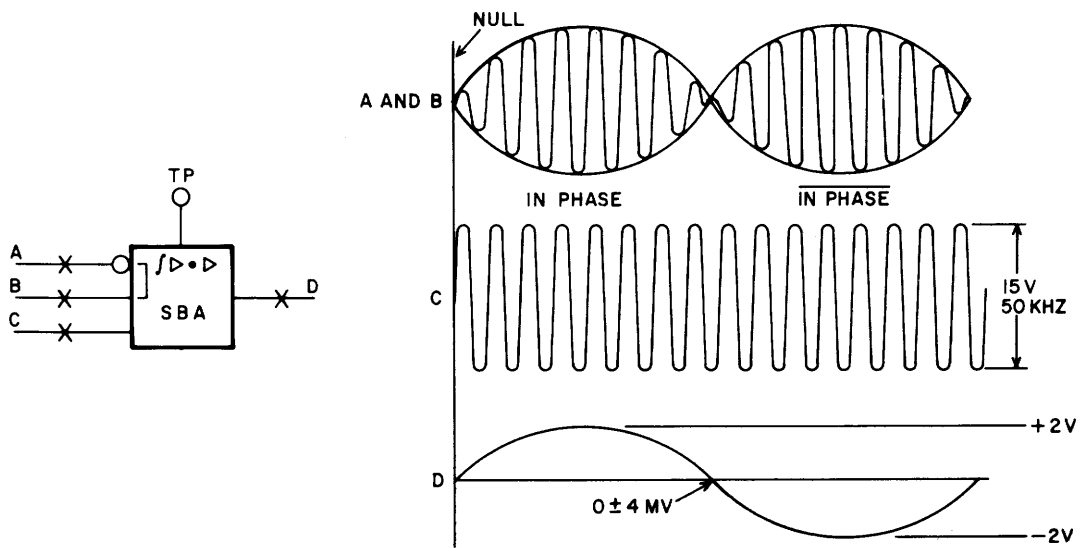

NOTE: VOLTAGE AND COMPONENT VALUES ARE FOR REFERENCE ONLY.

6T141

Figure 7-41. Demodulator - SBA

Attenuator - SBB/SBD

The SBB and SBD circuits (Figure 7-42) reduce the input voltage present at A by a factor of 3, approximately.

Capacitor NC1 filters the output voltage from voltage divider resistors NR1 and NR2. Series diodes NCR1 and NCR2 limit output B to a maximum of 1.6 volts. This limiting protects circuits driven by output B in the event of an abnormally high voltage being present at A. During normal operation, the diodes are nonconductive.

Voltage Divider - SBE/SBF

The SBE and SBF circuits (Figures 7-43) provide reference voltage outputs (0.744 volts SBE, 0.589 volts SBF) at A that are independent of normal variations in the 5-volt supply.

Resistor NR1 provides the zener diode NVR1 with approximately 20 ma from the 5-volt supply. This results in a very stable 3.6 volt reference. Resistors NR2 and NR3 divide the 3.6 volts to produce the desired ratio at output A. Capacitor NC1 filters the output.

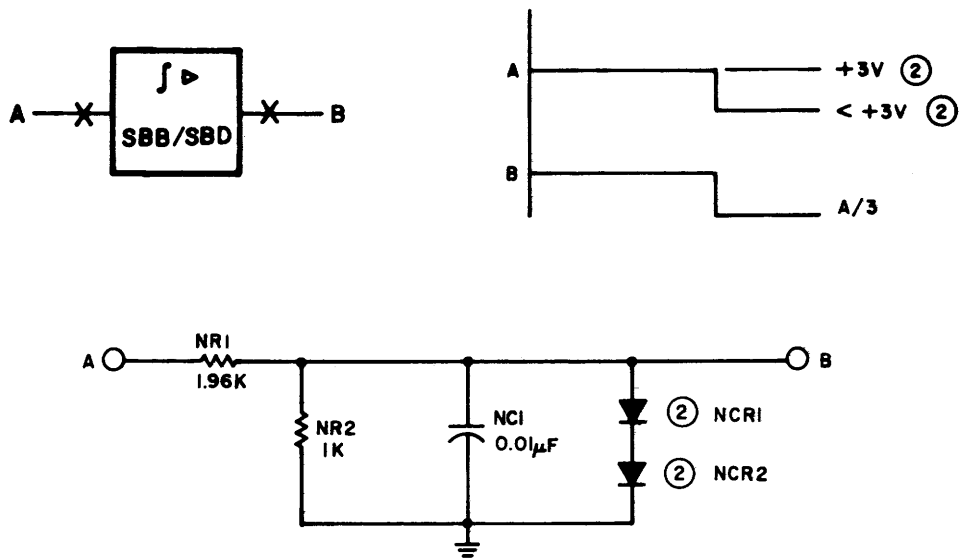

NOTES:

- 1 VOLTAGE AND COMPONENT VALUES FOR REFERENCE ONLY
- ② POLARITY REVERSED IN SBD CIRCUIT TYPE

6T154

Figure 7-42. Attenuator - SBB/SBD

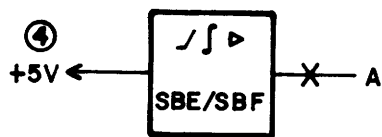

A = +0.744V FOR SBE
 A = -0.589V FOR SBF

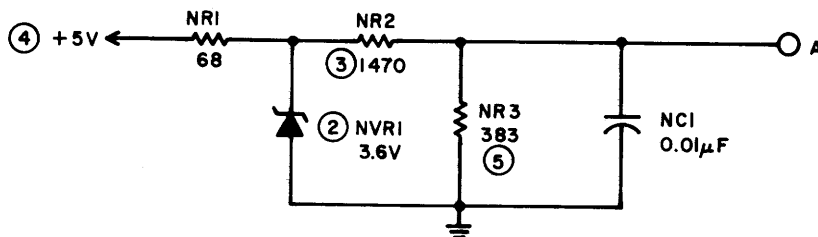

NOTES:

1. VOLTAGE AND COMPONENT VALUES FOR REFERENCE ONLY
- ② POLARITY REVERSED IN SBF CIRCUIT TYPE
- ③ VALUE IS 1780 OHMS IN SBF
- ④ -5V IN SBF
- ⑤ VALUE IS 348 OHMS IN SBF

6T151

Figure 7-43. Voltage Divider - SBE/SBF

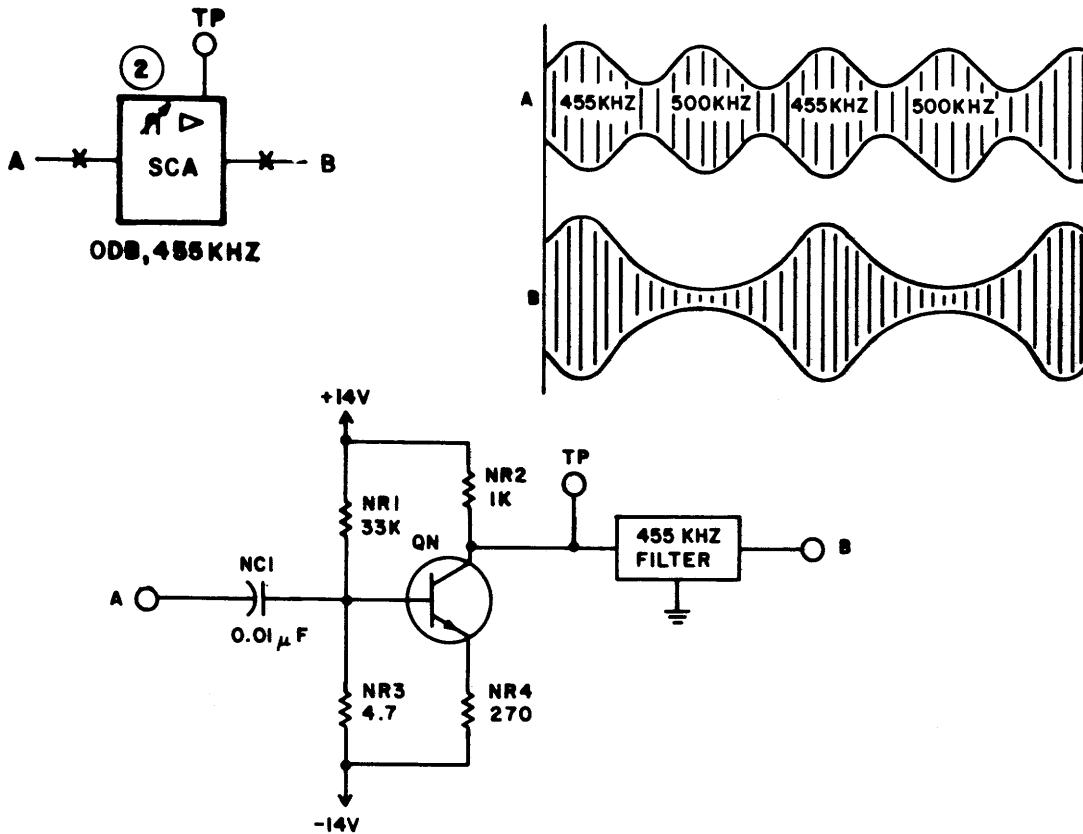

NOTES:

1. VOLTAGE AND COMPONENT VALUES ARE FOR REFERENCE ONLY.
- ② ADJUSTABILITY ARROW REFERS TO BALANCE POTENTIOMETER CONNECTED TO INPUT A.

8T164

Figure 7-44. Filter - SCA

Filter - SCA

The SCA circuit (Figure 7-44) amplifies and passes the 455 kHz component of the track servo signal, and blocks passage of the other signal component (500 kHz).

The circuit consists of a transistor voltage amplifier with a gain of 4.4 db and a ceramic, ladder-bandpass filter with an insertion loss of 4 db (max). As a result the signal incurs no voltage loss in the circuit.

The bandwidth at the -1 db point (relative to the center frequency attenuation) is 20 kHz minimum, at -2 db it is 30 kHz minimum, at -6 db it is 40 kHz minimum, and at -60 db it is 72 kHz maximum.

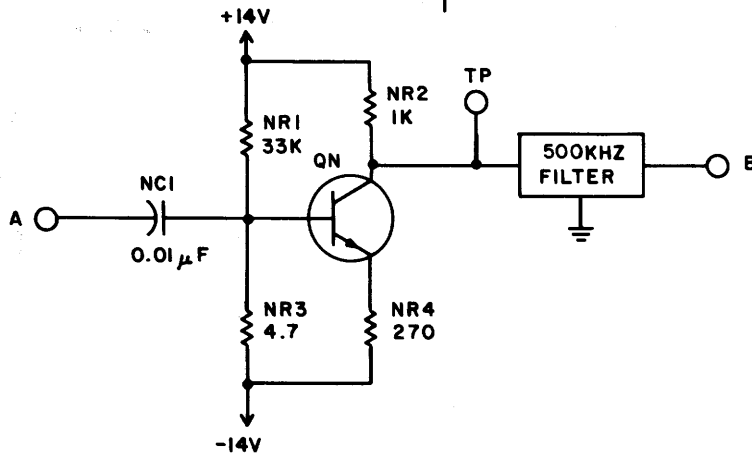
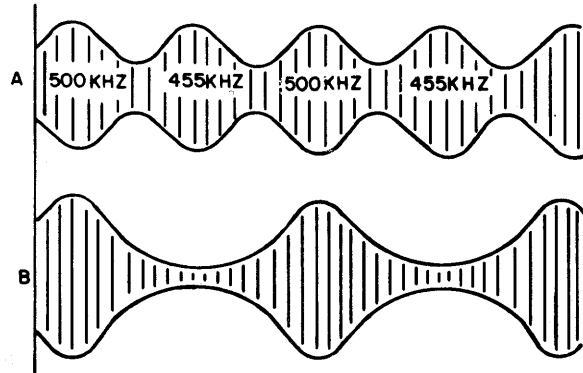
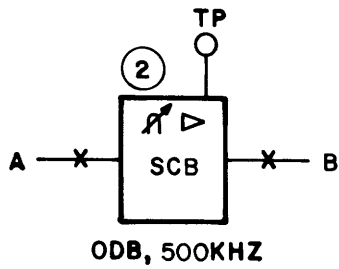

NOTES:

1. VOLTAGE AND COMPONENT VALUES ARE FOR REFERENCE ONLY.
- ② ADJUSTABILITY ARROW REFERS TO BALANCE POTENTIOMETER CONNECTED TO INPUT A.

6T165

Figure 7-45. Filter - SCB

Filter - SCB

The SCB circuit (Figure 7-45) is identical to the SCA circuit except that it passes the 500 kHz component of the track servo signal and blocks the 455 kHz component.

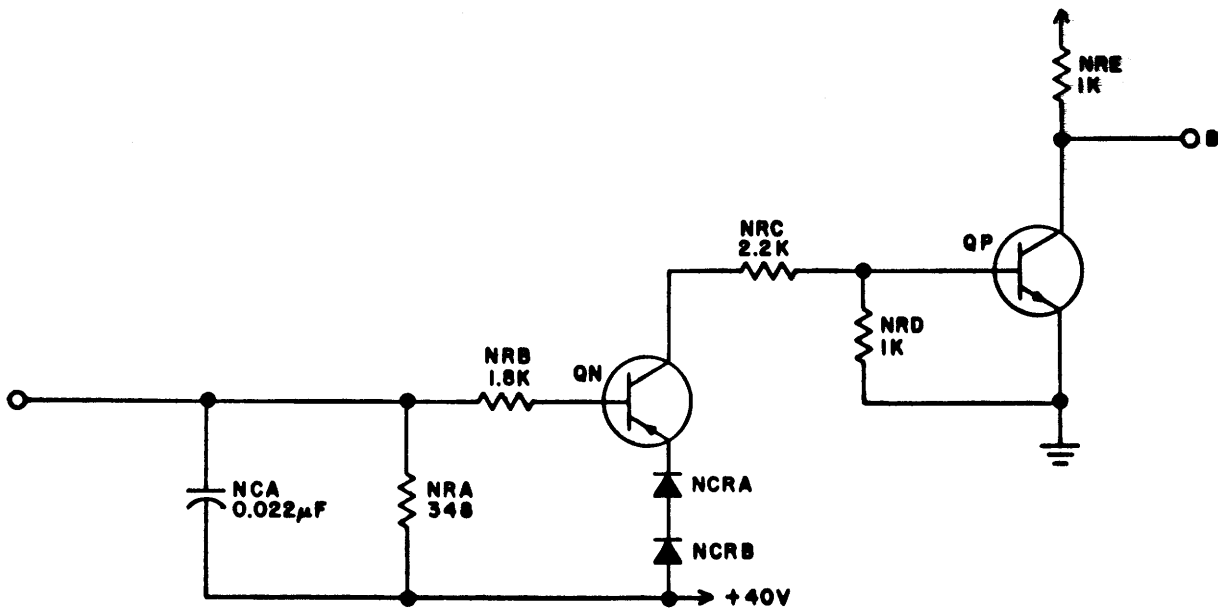
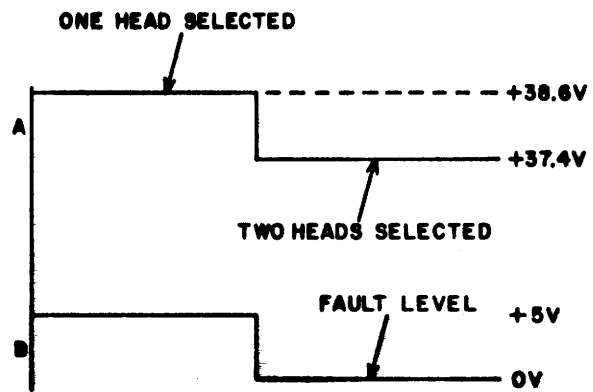
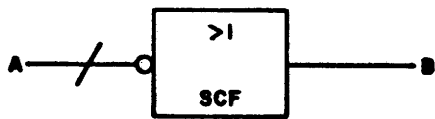

NOTE: VOLTAGE AND COMPONENT VALUES ARE FOR REFERENCE ONLY.

7K30

Figure 7-45. 1. Multiple Head Select Detector - SCF

Multiple Head Select Detector - SCF

The SCF circuit indicates +5 vdc at output B when no more than one head is selected. If two or more heads are selected, output B is 0 vdc.

Capacitor NCA filters transient voltages preventing a false indication of more than one head selected. Diodes NCRA and NCRB provide a voltage bias on the emitter of QN. Resistors NRA and NRB are a voltage divider network.

Input A is fed by all heads, each through 10K of resistance. When one head is selected, only one 10K resistor goes to ground through a head select transistor. The current flow through NRA will not cause sufficient voltage drop across NRB to forward bias QN.

When two or more heads are selected, two or more 10K resistors are switched to ground. This causes increased current through NRA. The voltage drop across NRB then decreases enough to forward bias QN. QN turns on, passing collector current through NRC into the base of QP. QP turns on, bringing output C from +5 vdc to 0 vdc.

Delay - UB

The capacitor delay circuits (Figure 7-46) delay a "1" input at A for a specified period of time before providing a "1" output at B. Delay time for a "0" pulse is negligible.

Assume a "0", ground, enters at A. If the capacitor is discharged, it remains discharged and the output remains "0". If the capacitor is charged when the "0" signal appears, the capacitor discharges almost instantaneously, and the "0" appears with no noticeable delay.

If a "1", +3 volts, enters A while the capacitor is discharged, the capacitor must first charge to a minimum "1" voltage before a "1" can appear at B. The required charge time is the delay time of the circuit. The charge time is dependent on the capacitor value, the resistance between the source voltage and the capacitor, and the minimum voltage required to produce a "1" output.

Delay times for capacitive delays used in the DSU are as follows:

Delay type	Time
UBD	200 nsec
UBE	0.5 ms
UBF	0.2 ms

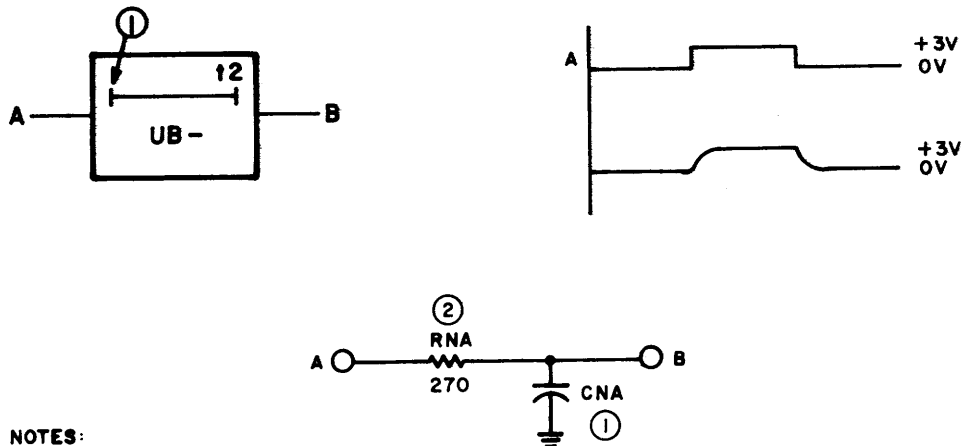

NOTES:

- ① VARIES WITH TYPE
- ② NOT USED ON UBF

6T155

Figure 7-46. Delay - UB

Unidirectional Time Delay - UEA

The UEA circuit (Figure 7-47) provides a 0.1- μ sec delay between the time that a -3.5v signal appears at A and the time that transistor QP turns off. Output at B is either ground or an open circuit.

When input A is near ground, QN is off. Transistor QP is on. The output is ground.

When input A goes to -3.5v, capacitor CNA begins charging. After 0.1 μ sec the base of QN is sufficiently negative to turn QN on. Transistor QP turns off. The output is an open circuit.

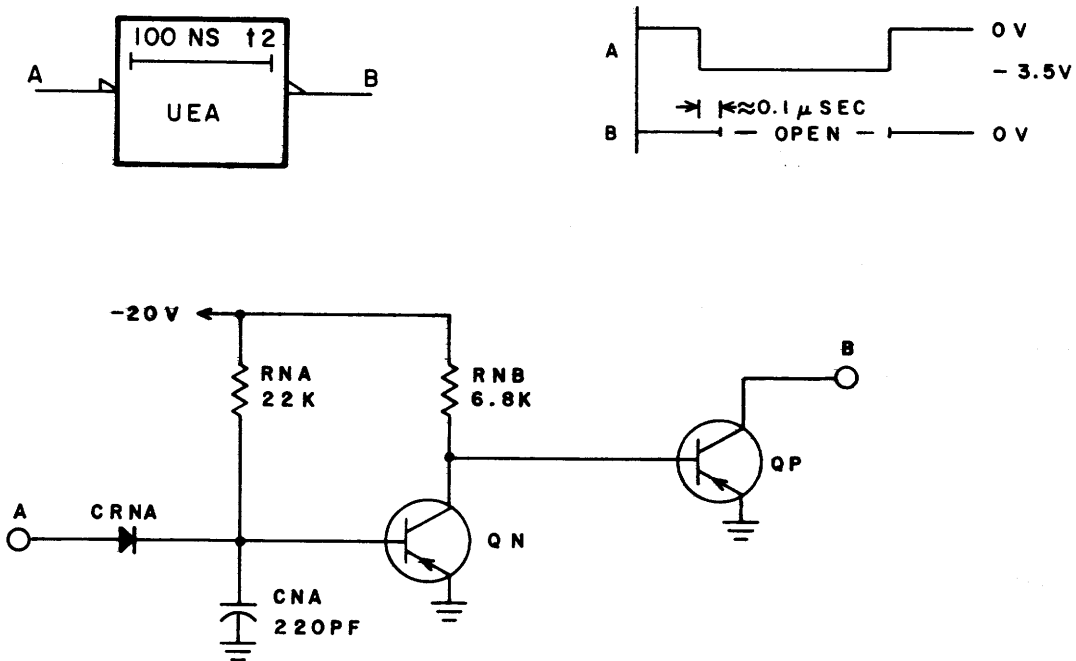

NOTE: VOLTAGE AND COMPONENT VALUES ARE FOR REFERENCE ONLY.

6T116

Figure 7-47. Unidirectional Time Delay - UEA

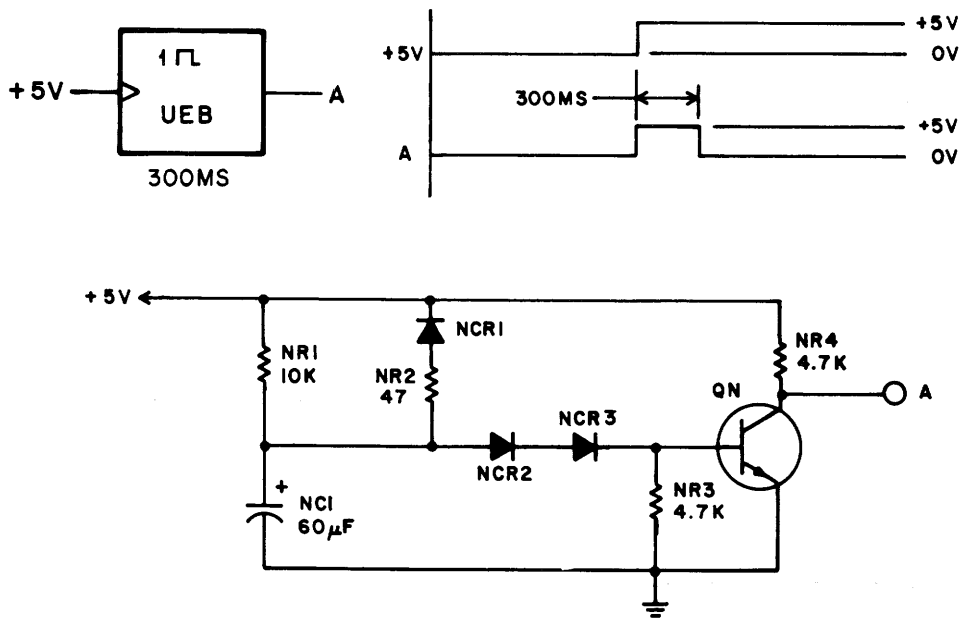

NOTE:
VOLTAGE AND COMPONENTS VALUES ARE FOR REFERENCE ONLY.

6T159A

Figure 7-48. Delay - UEB

Single Shot - UEB

The UEB circuit (Figure 7-48) is a single shot that holds a clear signal on the units Fault register for 300 ms after +5 volts becomes available.

The circuit delay characteristic occurs as NC1 charges through NR1 to a threshold voltage of 2.1 vdc (determined by NCR2, NCR3, and base-emitter junction of QN). Resistor NR2 and diode NCR1 provide a quick discharge path for NC1 when +5 volts drops. The presence of this path ensures a short recycle period for transient off/on application of the +5 vdc.

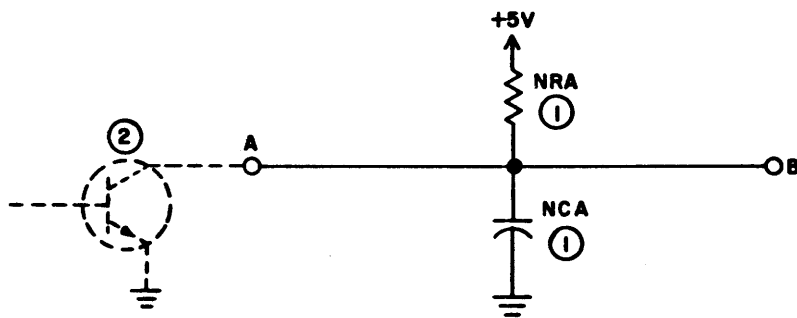
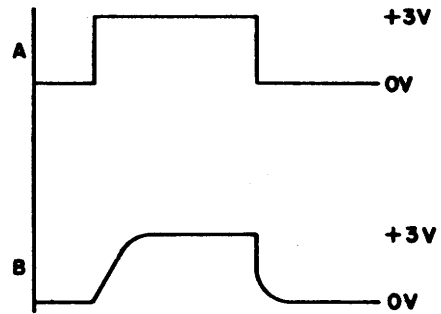
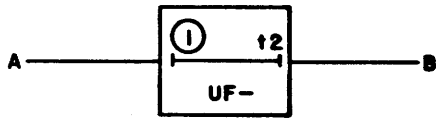

- NOTES: ① VALUE DEPENDENT ON CIRCUIT TYPE
 ② OPEN COLLECTOR TRANSISTOR IN PRECEDING STAGE

7K36

Figure 7-48.1. Delay - UF-

Delay - UF-

The UF- delay circuit is used to delay open collector integrated circuits. The circuit delays a "1" input before providing a "1" output at B. The delay time for a "0" pulse is negligible. The delay circuit consists of a resistor connected to +5v and a capacitor connected to ground.

Assume that a "0" (ground) enters at A. If the capacitor is discharged, it remains discharged. The output is an immediate "0". If the capacitor is charged when the "0" signal enters, it discharges almost instantaneously. The "0" appears at output B with no noticeable delay.

If a "1" (+3.0v) enters at A, and the capacitor is discharged, the capacitor must first charge to a minimum "1" voltage (typically +0.7v) before the "1" appears at output B. The time necessary to charge the capacitor to this minimum voltage is the delay time of the circuit. The charge time is dependent on the value of the capacitor, the value of the resistor, and the minimum voltage required to produce a "1" response.

Delay Type	Time
UFA	1.3 μ sec
UFB	0.5 μ sec
UFC	0.2 μ sec
UFD	6.0 μ sec

And - VAB

The VAB circuit (Figure 7-49) consists of two silicon peripheral logic inverters whose outputs share a common load resistor, RNE. When both inputs A and B are "0" (ground), the output at C will be a "1" (+3v). If either or both of the inputs are a "1", the output at C will be a "0". This is an AND gate for zeroes, or a NAND function.

When both A and B are at ground, QN and QP are off. The output at C is supplied from the +20v source through RNE. The output is a positive voltage, representing a non-logical "1". If input A experiences a positive voltage while B is at ground, QP turns on and conducts current from the +20v supply through RNE to ground. The "0" on B has no effect, as all the supply voltage is tapped to ground. The output at C is ground, or a "0". The situation is similar if A is "0" and B is "1". The output is "0". If both A and B have positive voltage applied to them, QN and QP both conduct. The output is "0".

Capacitors CNA and CNB provide a one's delay on input B and output C, respectively. They also maintain a noise barrier to isolate the circuit from stray pulses on the lines.

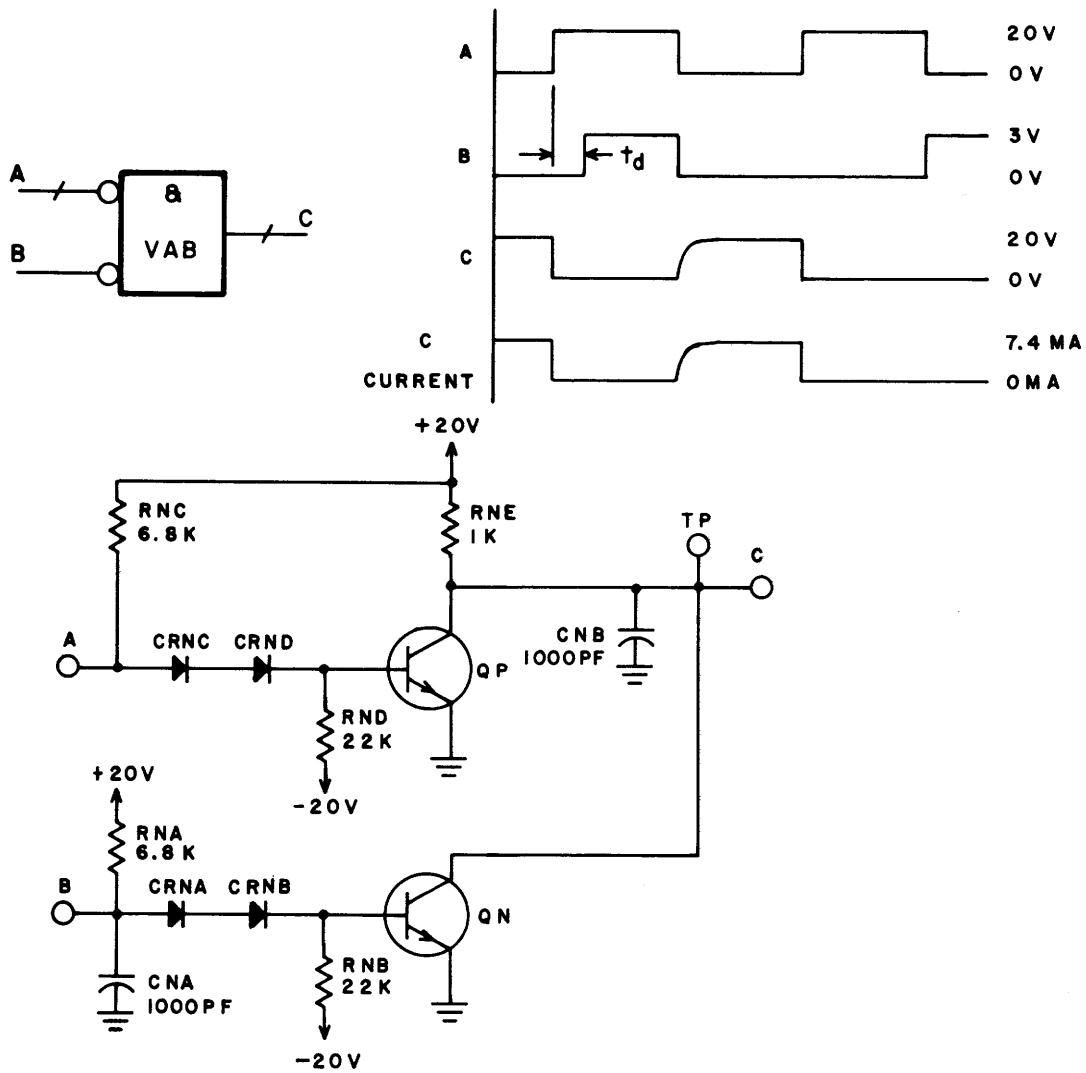

NOTE: VOLTAGE AND COMPONENT VALUES ARE FOR REFERENCE ONLY.

6T117

Figure 7-49. And - VAB

And/Or (Single Input) - VAC, VJW

The single input AND/OR or silicon peripheral logic (SPL) inverter (Figure 7-50) provides an inversion from input A to output B: A "1" on A produces a "0" on B, or a "0" on A produces a "1" on B. The inverter's output may be connected to the output of other inverters to form NAND functions or NOR functions.

The SPL inverter is a single NPN silicon transistor connected as a common emitter amplifier. When A is a "0" (between 0v and +0.3v) the transistor is off. This allows current to flow from the +20v supply, through RNB to output B. The output is a "1". When input A is a "1" (between +0.7v and +3.0v) the transistor turns on. The transistor conducts current from the +20v source, through RNB to ground. This leaves output B near ground, or a "0".

Since the base-emitter threshold for a silicon transistor is approximately +0.7v, the circuit ignores up to 0.5v of transient noise.

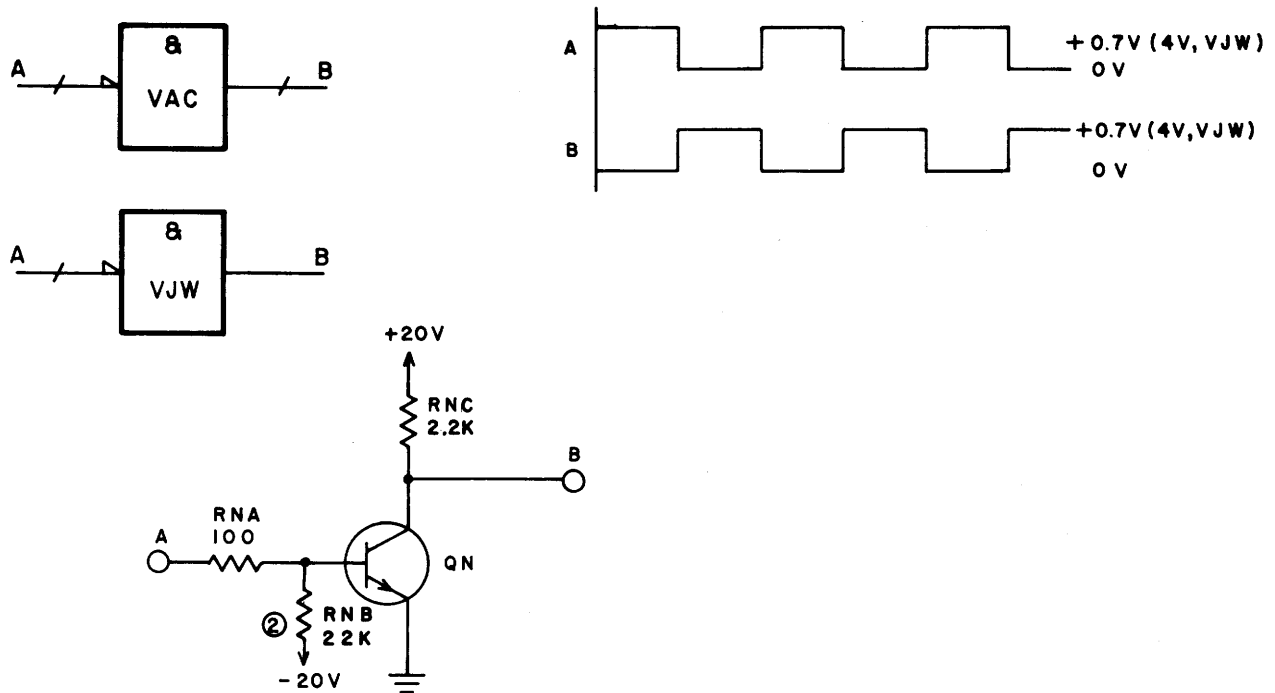

NOTES:

- 1. VOLTAGE AND COMPONENT VALUES ARE FOR REFERENCE ONLY.
- ② DOTTED LINE TO -20V AND RESISTOR RNB FOR VJW ONLY.

6T118

Figure 7-50. And/Or (Single Input) - VAC, VJW

If the circuit drives just one other transistor, the output may be connected directly to the base of the driven transistor. For a fan-out of 2 or more, a base isolation resistor is required for each driven transistor. This resistor ensures that the base drive provided to each of the driven transistors will be nearly independent of differences in base-emitter voltages. For a fan-out of 2 the collector load resistor must be reduced by one-half its value for driving one transistor to provide for the additional voltage drop across the isolation resistors.

Switching time for an inverter with a fan-out of 1 is typically 15 nsec.

Power Driver - VJK

The VJK circuit (Figure 7-51) is similar to the VJS circuit with the addition of capacitor CNB and two outputs. CNB slows the switching time of QN and provides a ramp output. Output B connects to the center tap of the head. Output C contains a 10K resistor and is connected to a voltage supply in a fault detect circuit. If two heads are selected the effective resistance falls to 5K (two 10K resistors in parallel). The increase in current causes a Fault signal. Output D contains a diode that isolates each Write Gate.

Power Driver - VJL

The VJL circuit (Figure 7-52) is a gate used to bias an analog gate.

If +20v appears at A, QN turns on. The base of QP goes to ground. Transistor QP is off. Capacitor CNA charges through RND to +20v. Output at B is a ramp to +20v.

A +0.2v signal at A turns QN off. When QP turns on, the collector voltage of QN clamps at +0.7v. CNA discharges rapidly through QP. Output B drops to ground.

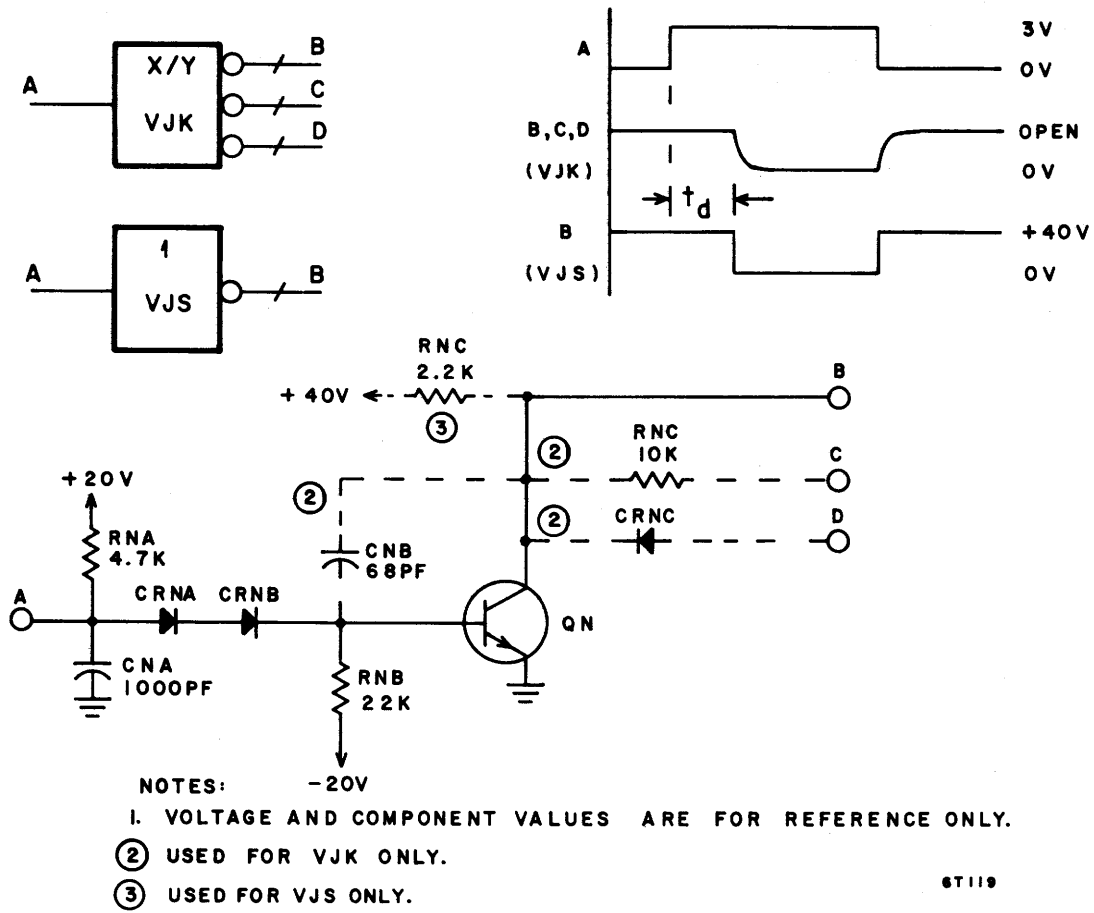
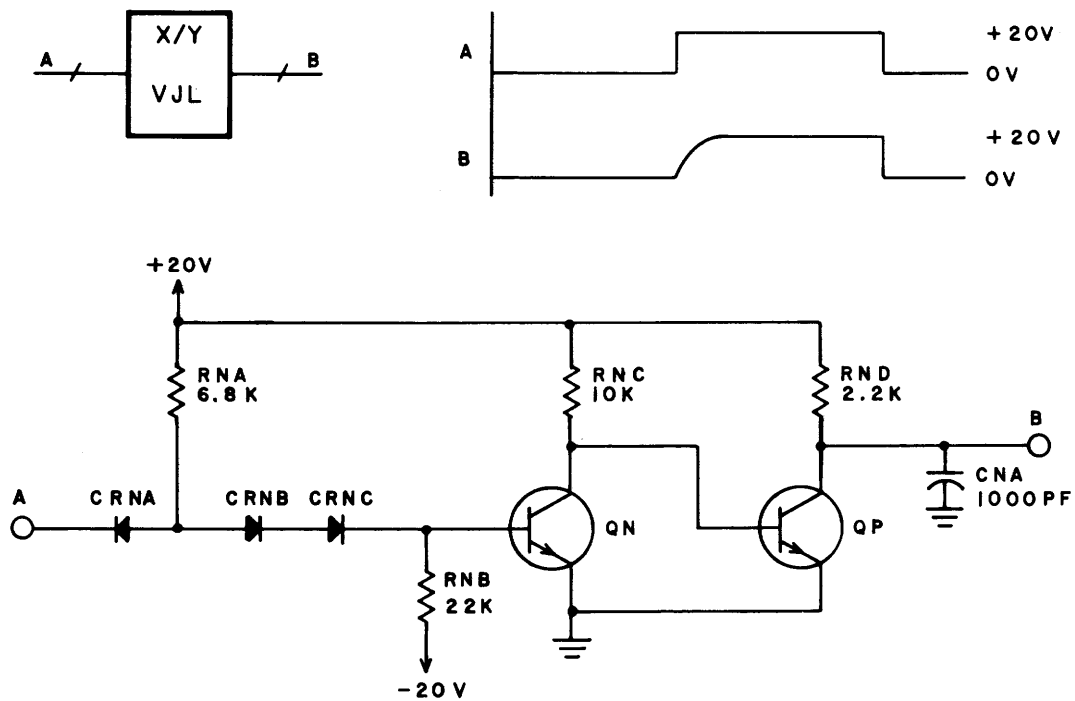

Figure 7-51. Power Driver - VJK, VJS



NOTE: VOLTAGE AND COMPONENT VALUES ARE FOR REFERENCE ONLY.
6T120

Figure 7-52. Power Driver - VJL

And - VJM

The VJM circuit (Figure 7-53) gates a particular receiver into operation. A "0" input at A results in an "open" enable signal to the receiver. A "1" input at A disables the receiver.

A "0" (0v) input forward biases diode CRNA. The +20v supply current is drawn through RNA and CRNA, leaving the base of QN reverse biased. Transistor QN is off. Output is held at -0.7v by the next stage.

A "1" input turns QN on. The output goes to ground. No receiver signal can pass into the receiver.

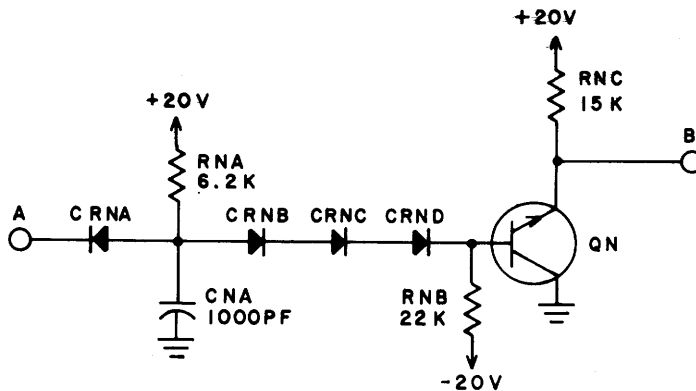
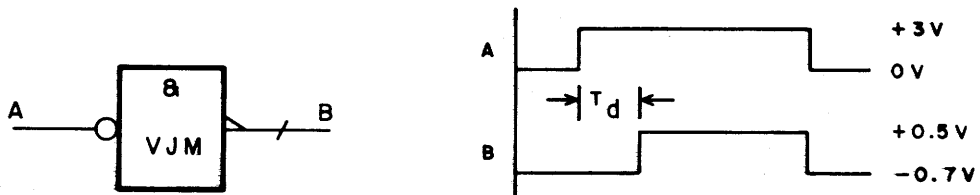

NOTE: VOLTAGE AND COMPONENT VALUES ARE FOR REFERENCE ONLY.

6T121

Figure 7-53. And - VJM

Or - VJN

The VJN circuit (Figure 7-54) is a NAND circuit that inverts the input signal. Input A is connected to the output of a receiver and to a gating circuit. If the Write gate is off, the base of QN is grounded. The circuit is disabled.

When the write gate is on, QN turns on and the receiver inputs a "0". Transistor QN turns on further and goes into saturation. Output voltage at B is approximately -0.2v.

When the receiver inputs a "1", QN comes out of saturation. Output at B is approximately -3.5v.

Whenever the write gate is on, QN is on to some degree. Only when the write gate is off is the base of QN at ground and QN off.

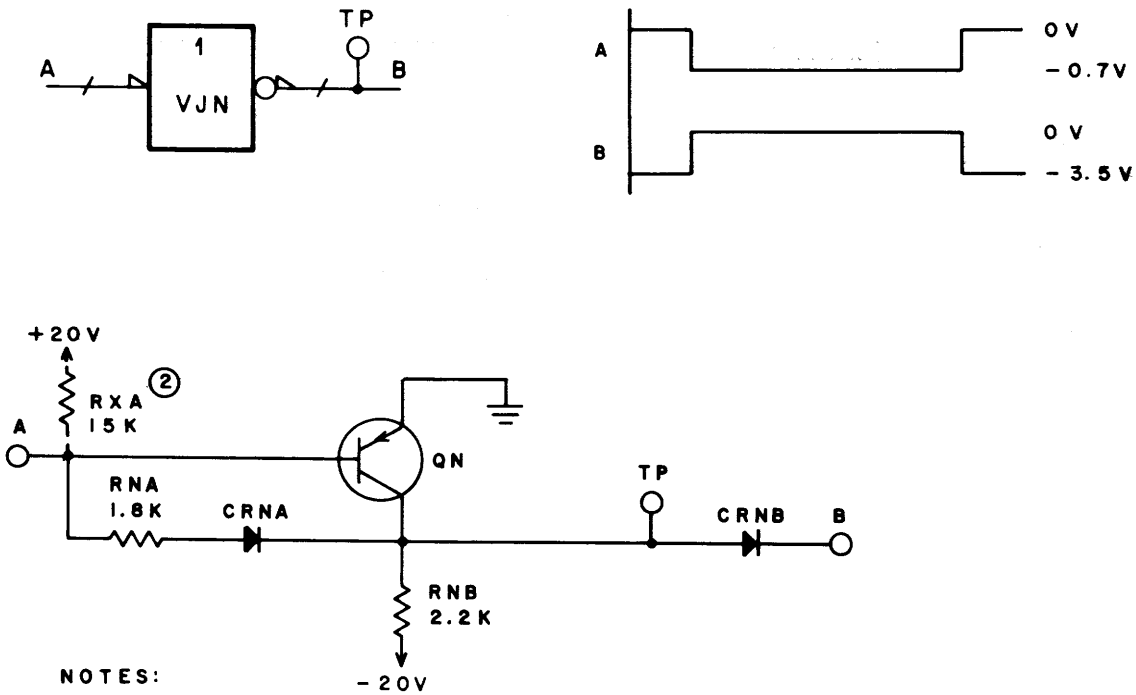

NOTES:
 1. VOLTAGE AND COMPONENT VALUES ARE FOR REFERENCE ONLY.
 2. RESISTOR AND POWER SUPPLY EXTERNAL TO VJN.

6T122

Figure 7-54. Or - VJN

And - VJP

The VJP circuit (Figure 7-55) is normally used as the input circuit to a toggle flip-flop. It ties two receiver outputs to a single-ended output. Capacitor CNA is used to reduce the input impedance for faster switching.

When input A is near ground, the base of QN is at approximately +0.9v. Transistor QN is off. Output at B approaches -20v, but is clamped at -3.8v by a Zener diode in the following circuit.

When input A is -3.5v, QN turns on. Output drops to approximately -0.2v.

Input to A is short (100 nsec), negative, data pulses. Output B is also short pulses.

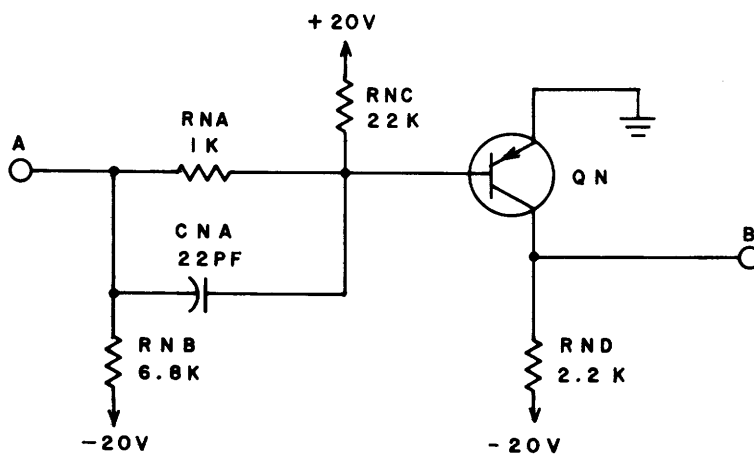
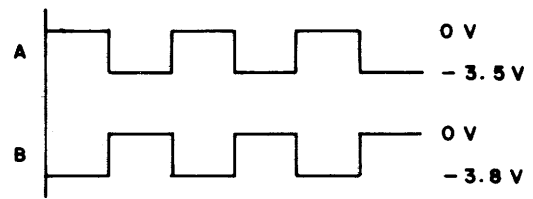
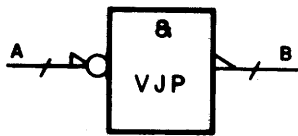

NOTE: VOLTAGE AND COMPONENT VALUES ARE FOR REFERENCE ONLY.

6T123

Figure 7-55. And - VJP

Power Driver - VJR

The VJR circuit (Figure 7-56) is a +40v switch. A "1" on input A produces +40v at output B. A "0" on input A stops current flow.

A "1" input turns QN on. Transistor QN conducts current from the +40v supply, causing a voltage drop across resistor RNB. This voltage drop turns on QP. Output B is at +40v.

A "0" input turns QN off. Since current no longer flows, the emitter and base of QP are at equal voltage. Transistor QP is off. Output B goes to ground.

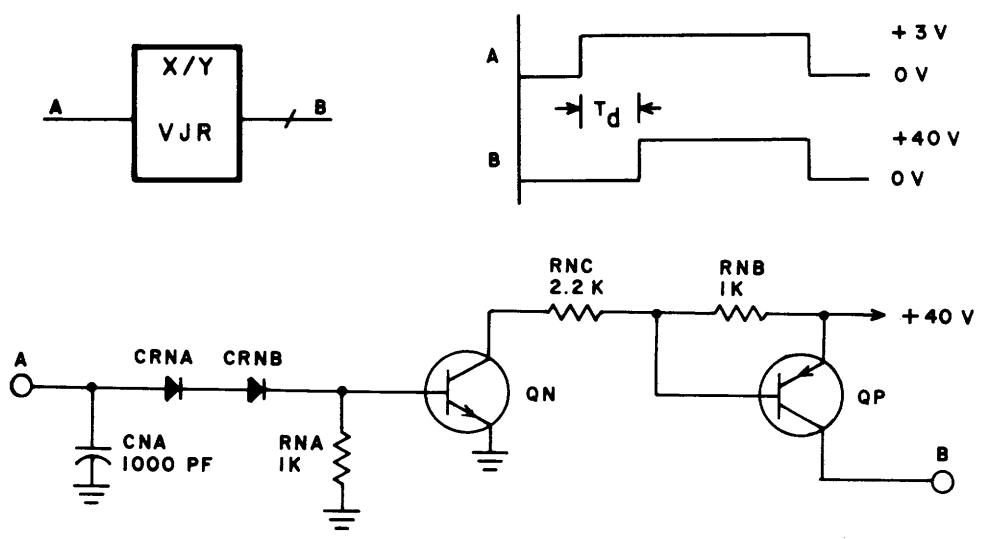

NOTE:
VOLTAGE AND COMPONENT VALUES
ARE FOR REFERENCE ONLY.

6T124

Figure 7-56. Power Driver - VJR

Or - VJS

The VJS circuit (Figure 7-51) is a standard inverter with a capacitor delay at the input. A "1" at input A pulls the output at B to ground. A "0" produces a +40v output.

Or - VJT

The VJT Circuit (Figure 7-57) is a gate to the WBB toggle flip-flop. A "1" input at A produces a ground at B, which keeps the flip-flop off. A "0" input at A produces a -3.5v output at B, which releases the flip-flop and presets it in a given state.

When a "0" is applied to input A, the base of QN goes to ground. Transistor QN is off. The base of QP is clamped at +0.6v by diode CRNC. Transistor QP is off. Output B is -3.5v derived from the voltage dividing network of RNF and RNG.

When A goes to a "1", capacitor CNA charges. After a delay, the base of QN is positive enough to turn QN on. The base of QP goes negative through resistor RNE. Transistor QP turns on. The output at B drops to ground.

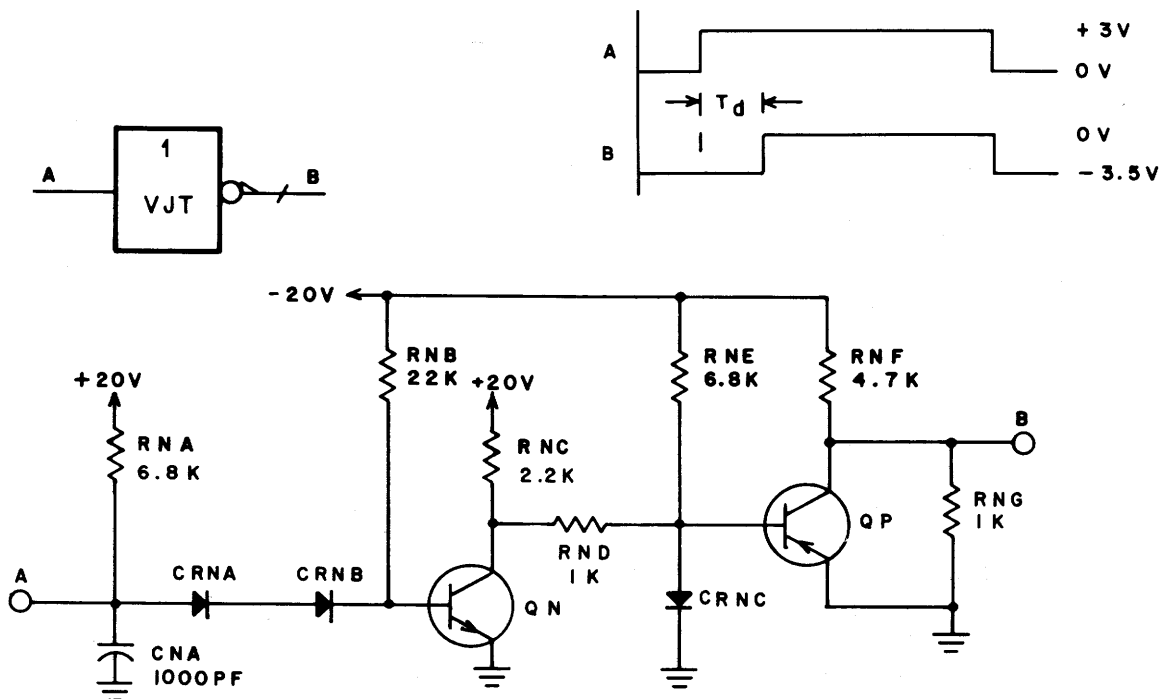

NOTE: VOLTAGE AND COMPONENT VALUES ARE FOR REFERENCE ONLY.

6T125

Figure 7-57. Or - VJT

And - VJU, VJV

The VJU and VJV circuits (Figure 7-58) are functionally identical. They consist of a standard inverter circuit with a capacitive filter input. The capacitor also presents a delay.

A "1" on input A reverse biases diode CRNA. Capacitor CNA charges through RNA until it is clamped at about 3 diode voltages (approximately 2.1v). QN turns on. Output B falls to ground.

If input A is a "0", CNA discharges through CRNA. Transistor QN turns off. Output B rises to a "1" level due to the clamping by a Zener diode.

And Or - VJW

Refer to circuit description for circuit type VAC.

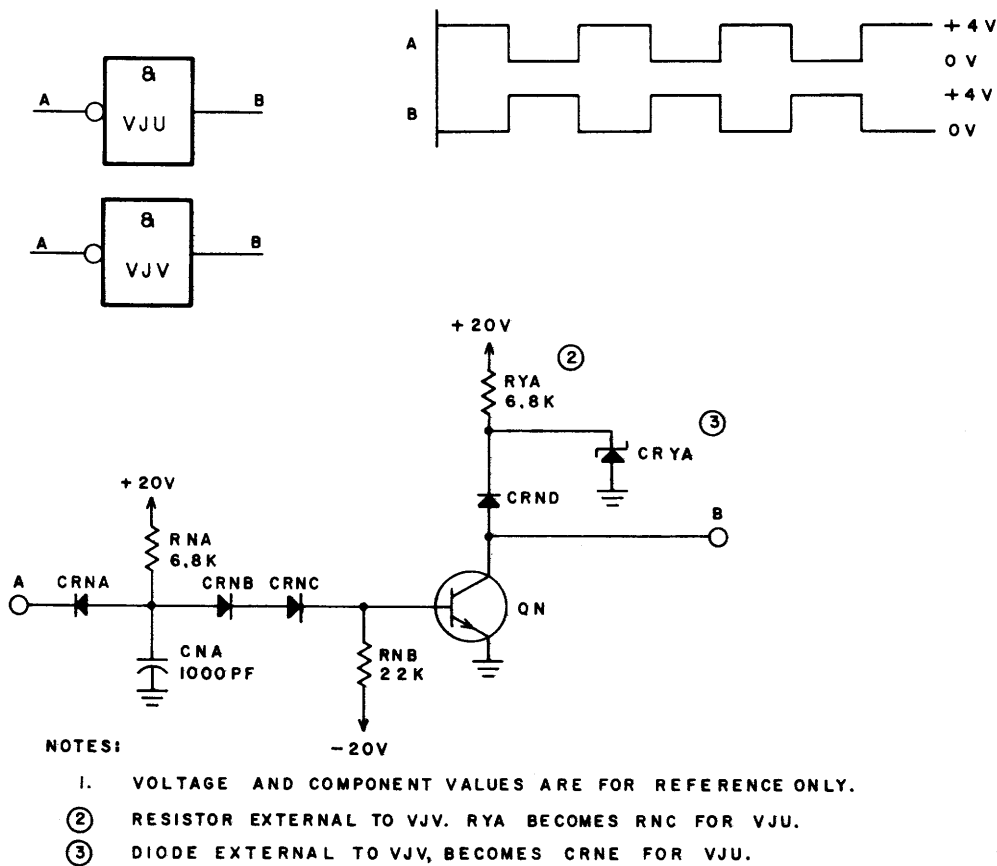
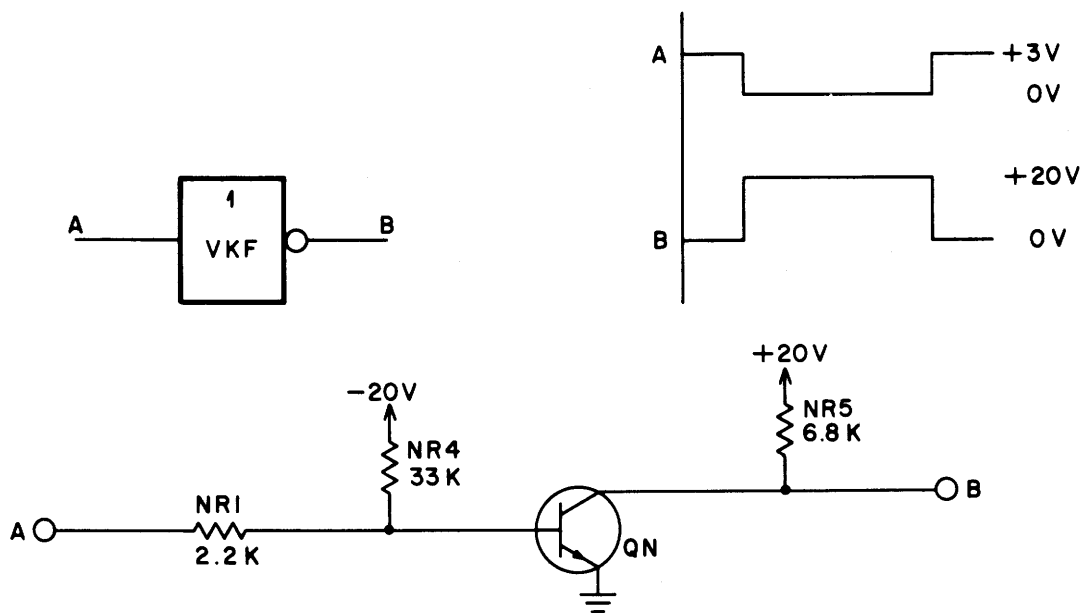

Figure 7-58. And - VJU, VJV

Inverter - VKF

The VKF circuit (Figure 7-59) is a simple digital inverter. It consists of a single NPN transistor in a common emitter configuration. A "0" at A turns QN off. This allows current to flow from the +20-volt supply, via NR5, and raise output B to a +20v level.

An input of "1" turns QN on. This directs current from the +20-volt supply through NR5 and QN to ground, leaving output B near a ground level.



NOTE: VOLTAGE AND COMPONENT VALUES ARE FOR REFERENCE ONLY.

6T142

Figure 7-59. Inverter - VKF

Or Gate - VKG

The VKG circuit (Figure 7-60) detects the presence of write or erase current flow. When current flows, a voltage drop across an external resistor produces a voltage at input A that is lower than V_{CC} (+40 volts) less 3.6 volts. This acts to turn QN on and QP and QQ turn off to produce a "1" at B. If the current flow drops to a level that would impair the write operation, QN will turn off. This causes QP and QQ to turn on and a "0" to appear at B, indicating a fault.

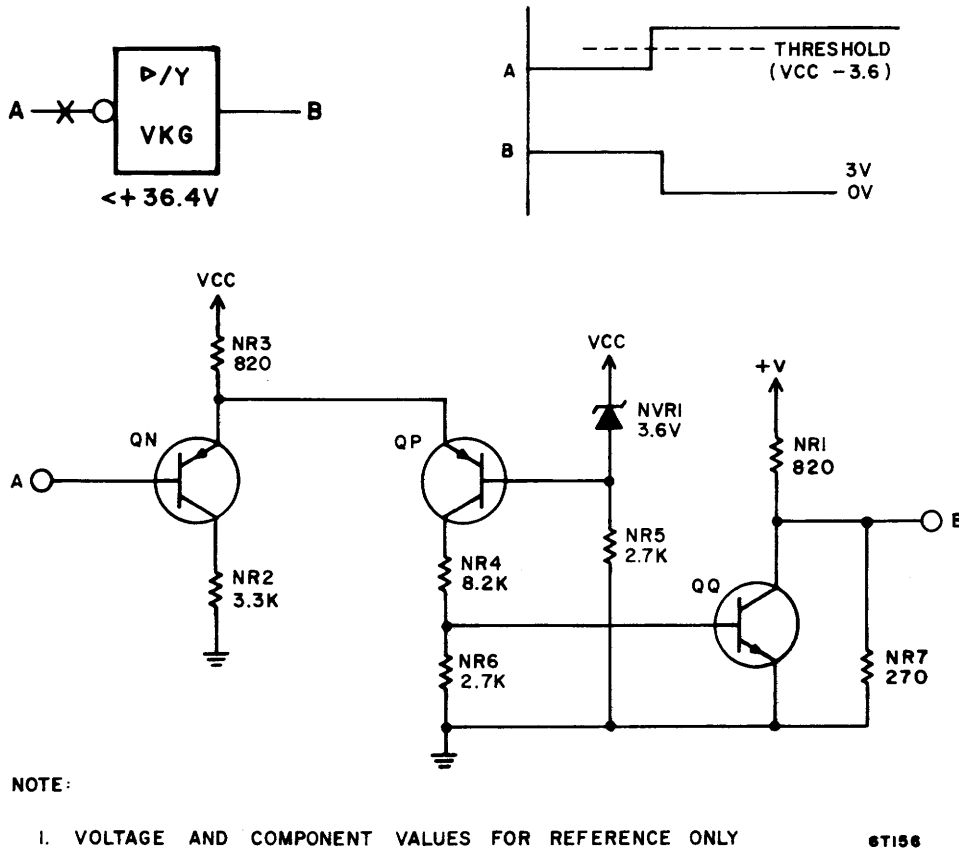

Figure 7-60. OR - VKG

Current Detector - VKH

The VKH circuit (Figure 7-61) detects the undesirable occurrence of multiple head selection.

Input A connects to the head select circuits. The selection of a head causes current to be drawn through resistor NR1. As long as a single head is selected, the voltage at the base of QN is insufficient to turn QN on. As a result, the circuit output, B, will remain at zero volts.

If more than one head is selected, the additional current flowing through NR1 causes QN to turn on. This produces a "1" at output B, indicating a fault.

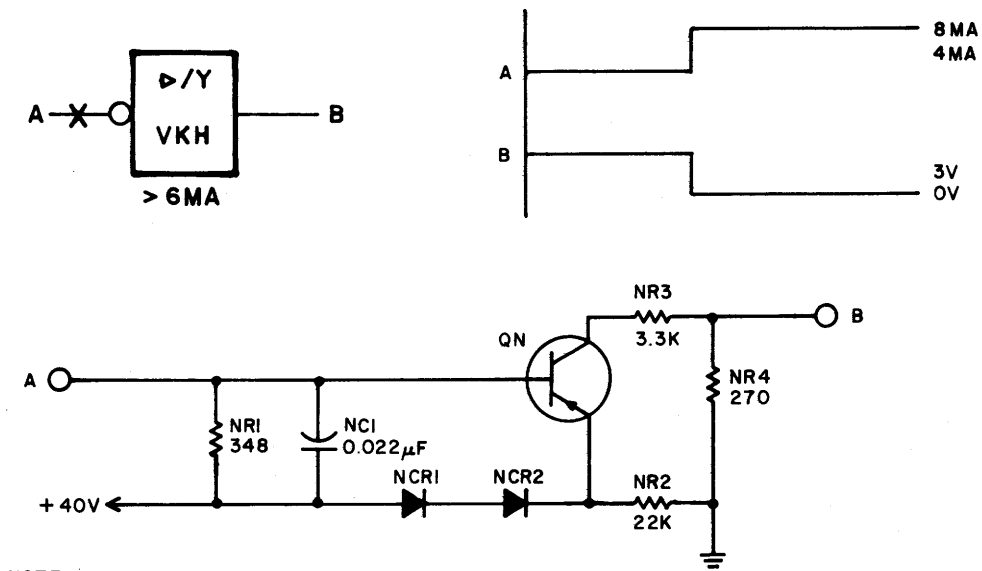

NOTE:

I. VOLTAGE AND COMPONENT VALUES FOR REFERENCE ONLY

6T157

Figure 7-61. Current Detector - VKH

And Gate - VKJ

The VKJ circuit (Figure 7-62) guards against the write head receiving current except during a write operation.

When input A is a "0", QN is off and output B makes +40 volts available for write current. If the input is a "1", QN is on, output B approaches zero volts, and no write current is available to the write heads.

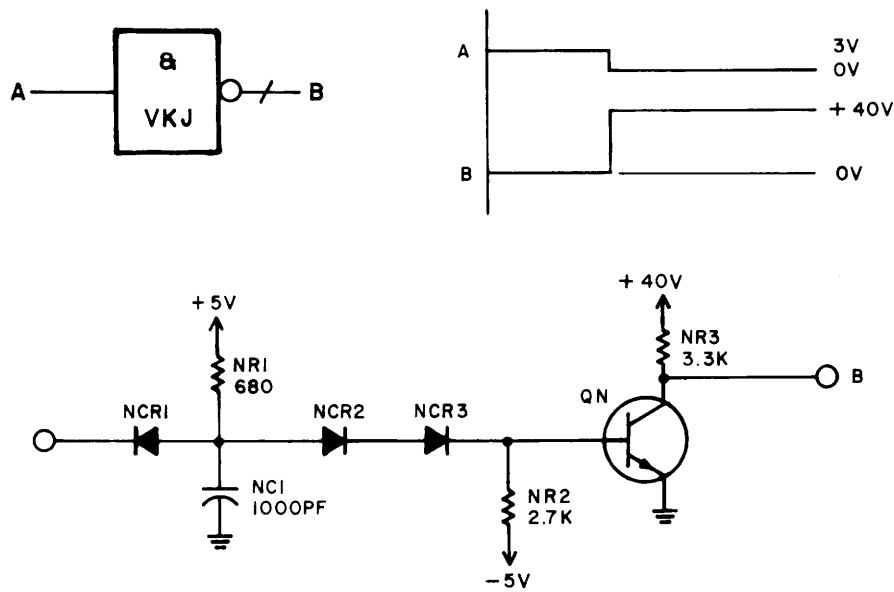

NOTE:

1. VOLTAGE AND COMPONENT VALUES FOR REFERENCE ONLY

6T149

Figure 7-62. AND - VKJ

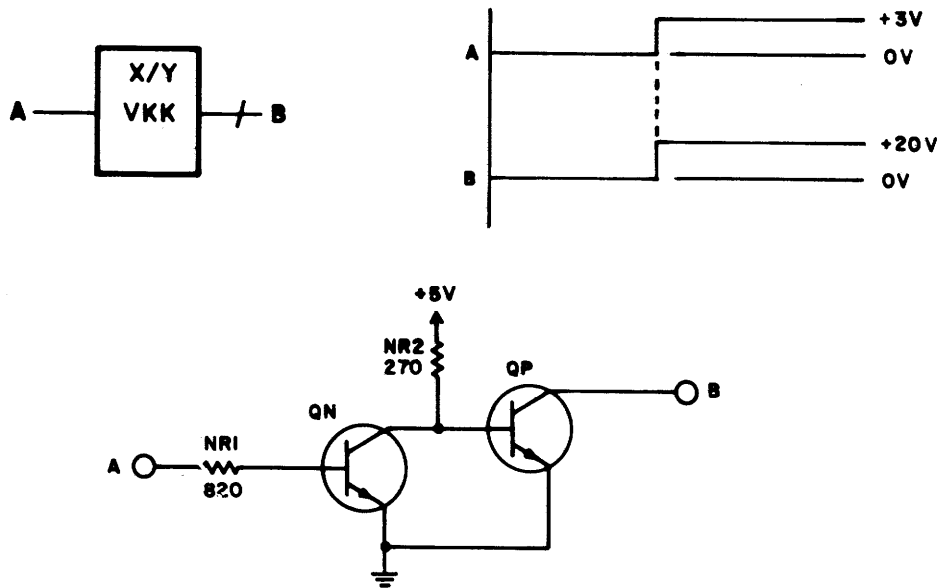

NOTE:

VOLTAGE AND COMPONENT VALUES ARE FOR REFERENCE ONLY.

6T168

Figure 7-63. Solenoid Driver - VKK

Solenoid Driver - VKK

The VKK circuit (Figure 7-63) is a solenoid driver that operates under control of a TTL circuit. Circuit output B connects to one side of the solenoid coil with the other end of the coil connected to +20 vdc.

A logic "1" at input A turns transistor QN on pulling the base of QP to ground. With transistor QP off, output B is at +20 volts and the solenoid armature is de-energized. A logic "0" at input A turns QN off causing QP to conduct and output B to go to ground. The presence of a ground at B energizes the solenoid.

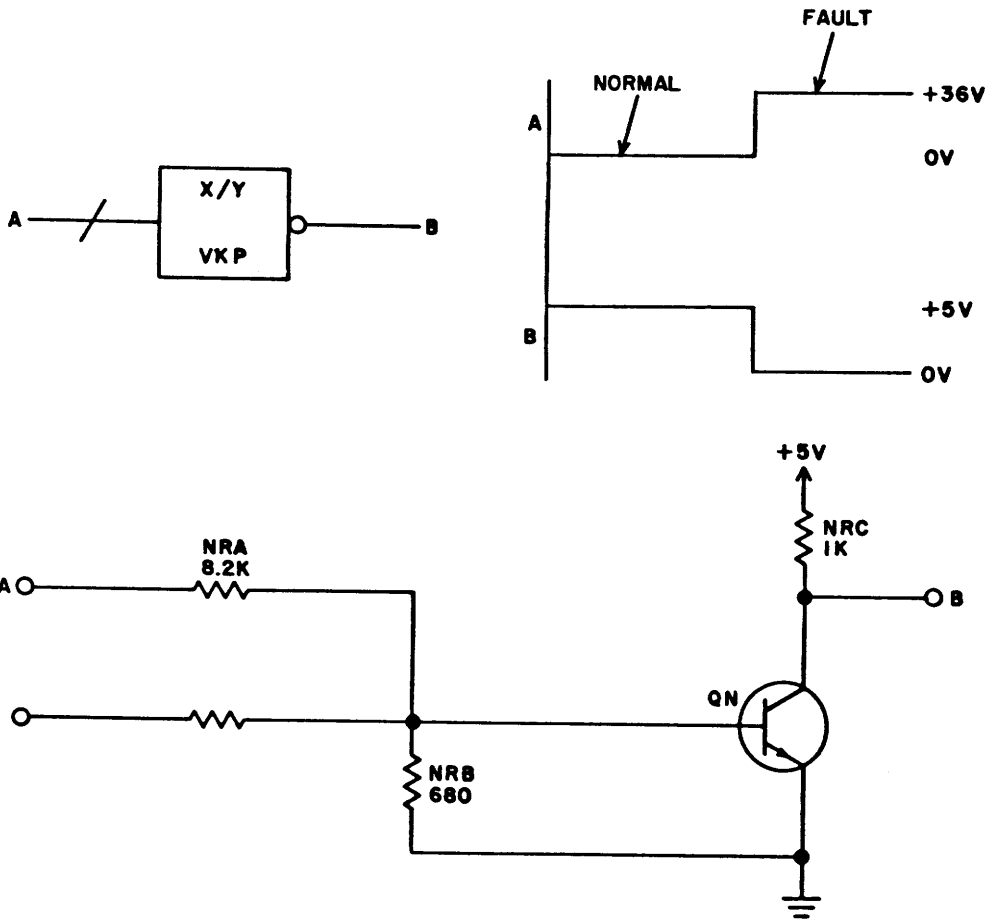

NOTE: VOLTAGE AND COMPONENT VALUES ARE FOR REFERENCE ONLY. 7K32

Figure 7-63.1. Level Translator - VKP

Level Translator - VKP

The VKP circuit connects input A to the writer side of the DC Current Detector (VKR). It converts the non-standard input level to a standard TTL level at output C.

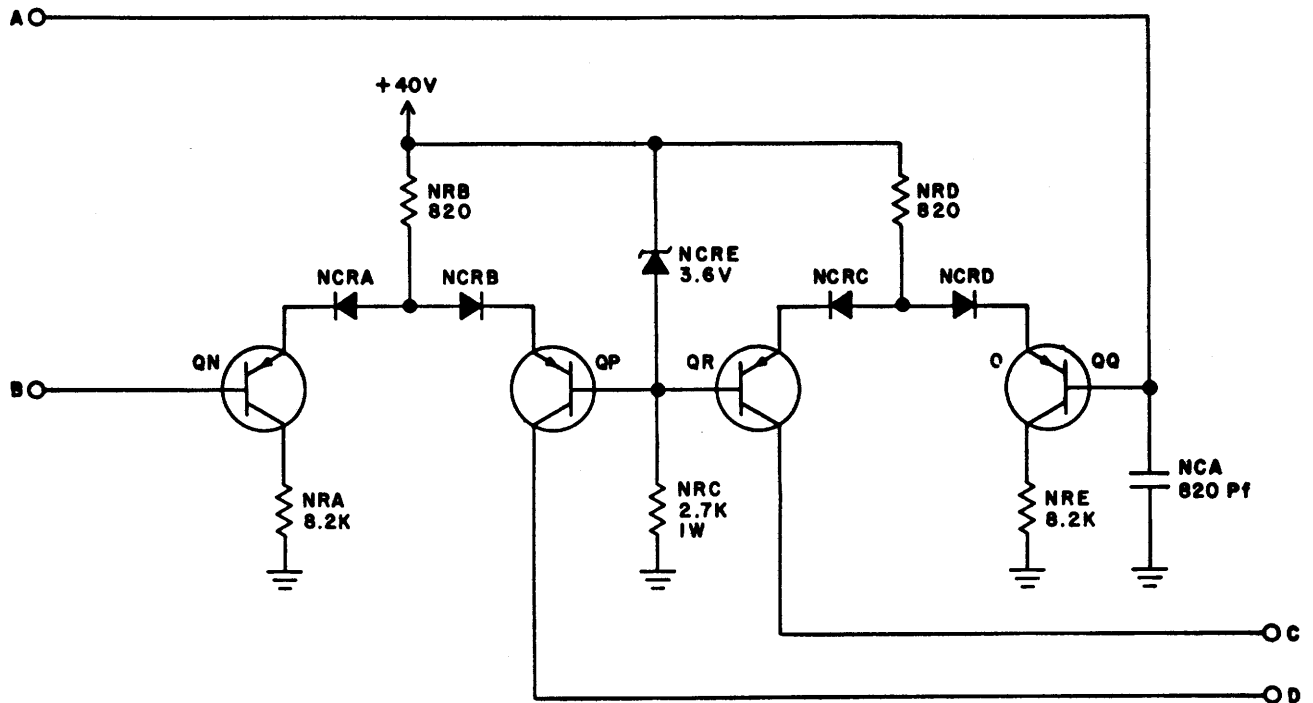
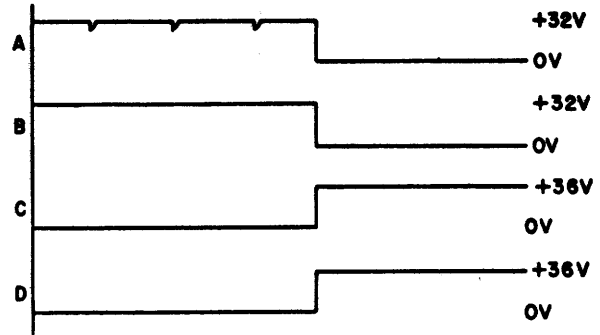
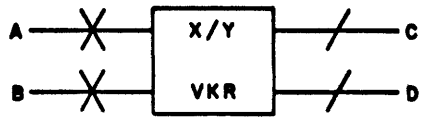

NOTE: VOLTAGE AND COMPONENT VALUES ARE FOR REFERENCE ONLY.

7K31

Figure 7-63.2. DC Current Detector - VKR

DC Current Detector - VKR

The VKR circuit is made up of two comparator stages. The write current detection stage consists of transistors QR and QQ, resistors NRD and NRE, diodes NCRC and NCRD, and capacitor NCA. The erase current detection stage consists of transistors QN and QP, resistors NRA and NRB, and diodes NCRA and NCRB. A reference voltage for both stages is provided by zener diode NCRE and resistor NRC.

Input A comes from the write driver circuit where the two driver transistor collectors are common. With the write driver circuit operating properly, input A is less positive than the reference voltage, QQ is on, and QR is off. Hence output C is at 0 vdc.

As the write current drops, input A becomes more positive until QQ is turned off. This turning QR on, causing output C to go to +36 vdc. Capacitor NCA filters out switching transients.

Input B comes from the erase driver circuit. Output D is used for this comparator stage. Operation of the erase comparator is identical to the write comparator.

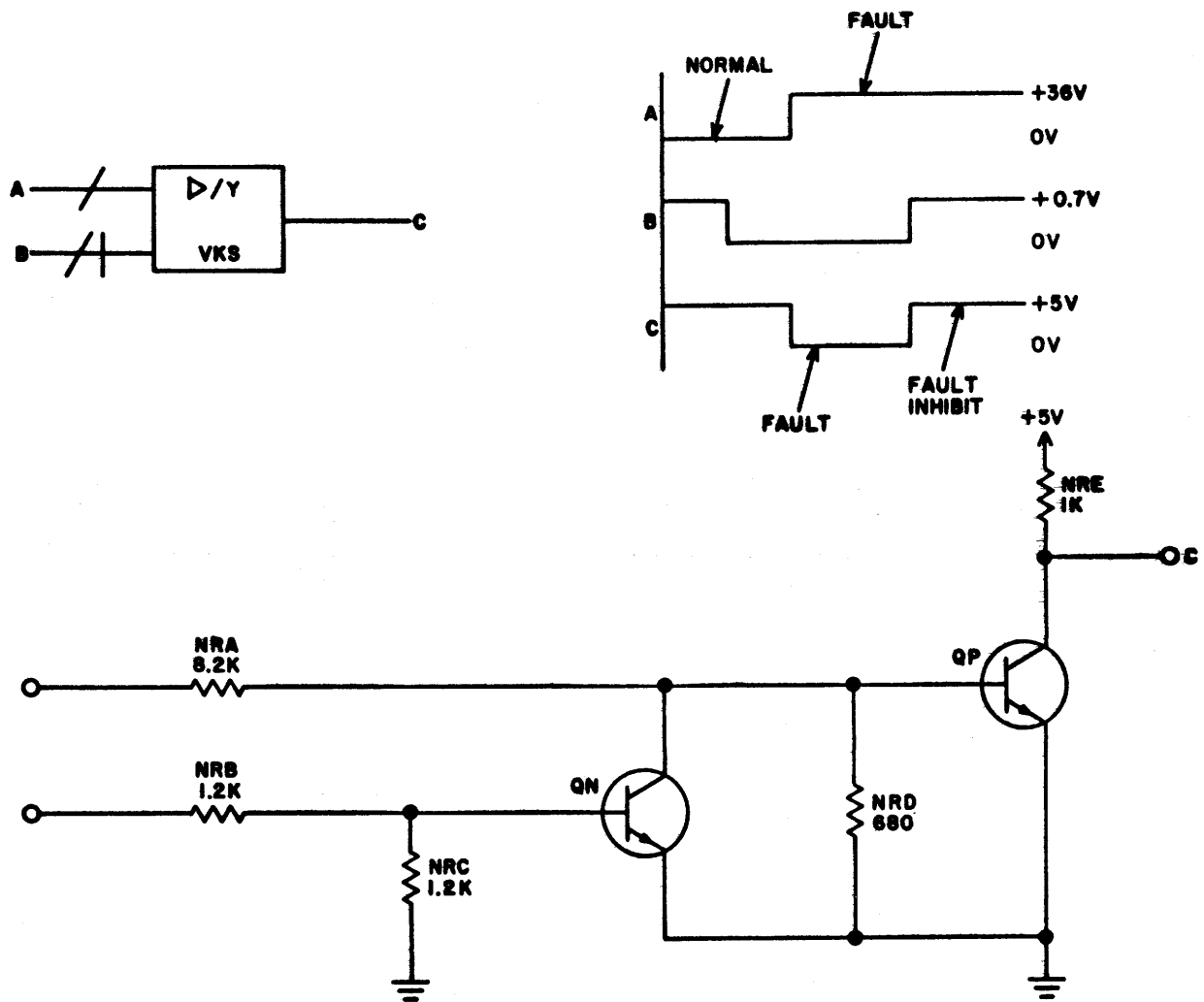

NOTE: VOLTAGE AND COMPONENT VALUES ARE FOR REFERENCE ONLY.

7K33

Figure 7-63.3. Gated Level Translator - VKS

Gated Level Translator - VKS

The VKS circuit connects input A to the erase side of the DC Current Detector (VKR). It converts the non-standard input level to a standard TTL level.

Transistor QN and resistors NRB and NRC form an inhibit gate. A fault indication is passed on when input B is 0 vdc, and inhibited when input B is +0.7 vdc.

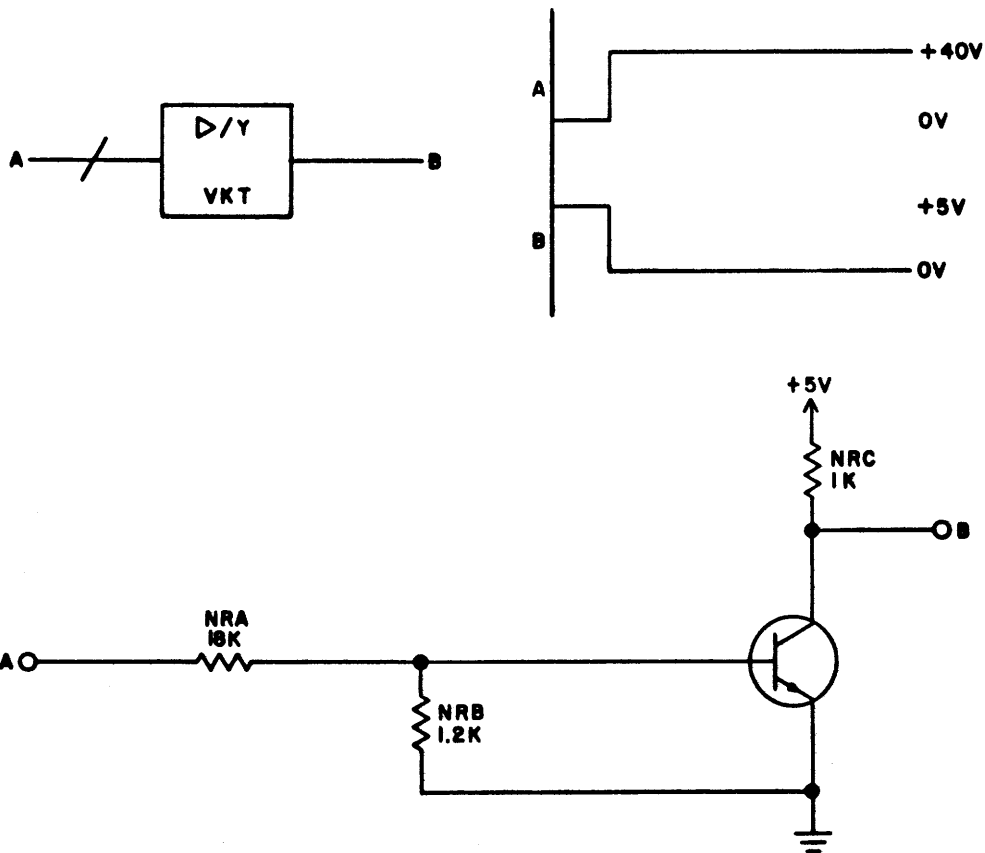

NOTE: VOLTAGE AND COMPONENT VALUES ARE FOR REFERENCE ONLY. 7K34

Figure 7-63.4. Erase Cutoff Detector - VKT

Erase Cutoff Detector - VKT

The VKT circuit converts a non-standard input A to a standard TTL level at output B. When the erase circuit is on, input A is +40 vdc, QN is on, and output B is 0 vdc. When erase is off, input A is 0 vdc, QN is off and output B is +5 vdc.

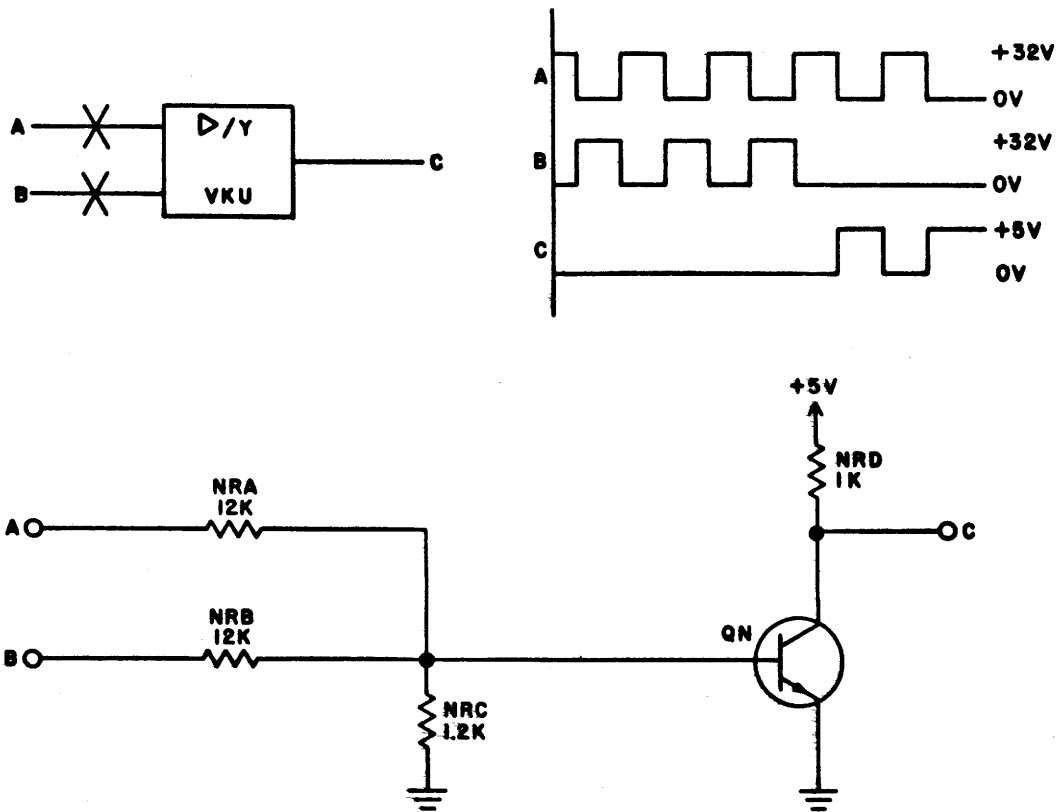

NOTE: VOLTAGE AND COMPONENT VALUES ARE FOR REFERENCE ONLY. 7K27

Figure 7-63.5. Write Shutoff Detector - VKU

Write Shutoff Detector - VKU

The VKU circuit is an "or" function that outputs 0v under normal write operations. Inputs A and B come from the output of the Write Driver. A voltage present on either A or B turns QN on. If only half of the write driver is functioning, output C toggles. If neither side of the write driver is functioning, output C is a static "1".

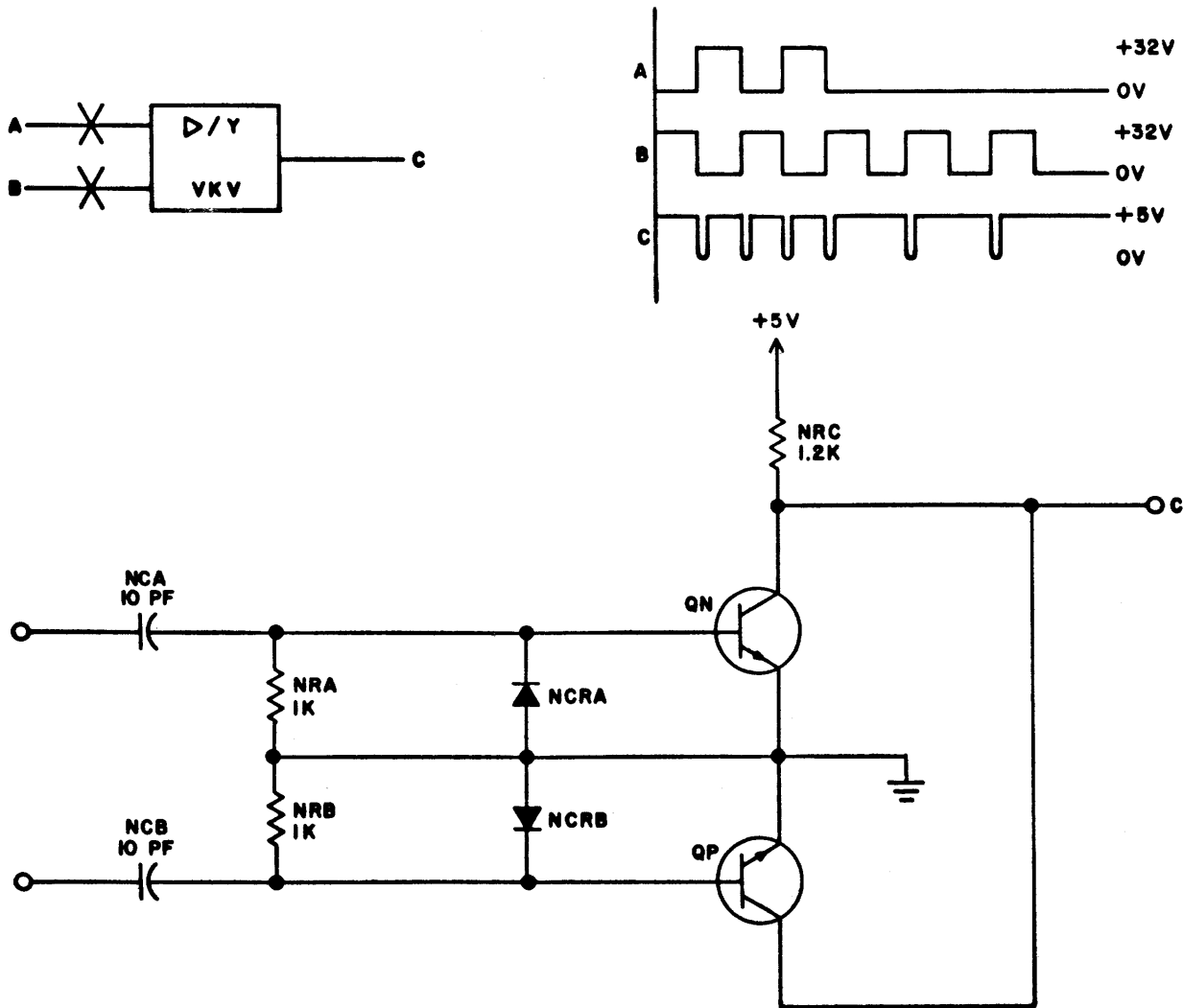

NOTE: VOLTAGE AND COMPONENT VALUES ARE FOR REFERENCE ONLY.

7K28

Figure 7-63.6. AC Write Current Detector - VKV

AC Write Current Detector - VKV

The VKV circuit outputs a negative-going pulse for each positive transition of the write driver. When input A goes positive, NCA charges, turning QN on. This causes output C to go 0v. When NCA is fully charged, QN is turned off and output C goes back to +5v. QP works in the same manner. Diodes NCRA and NCRB limit the negative transitions at the base of QN and QP to 0.7v. When write is off, output C is a "1".

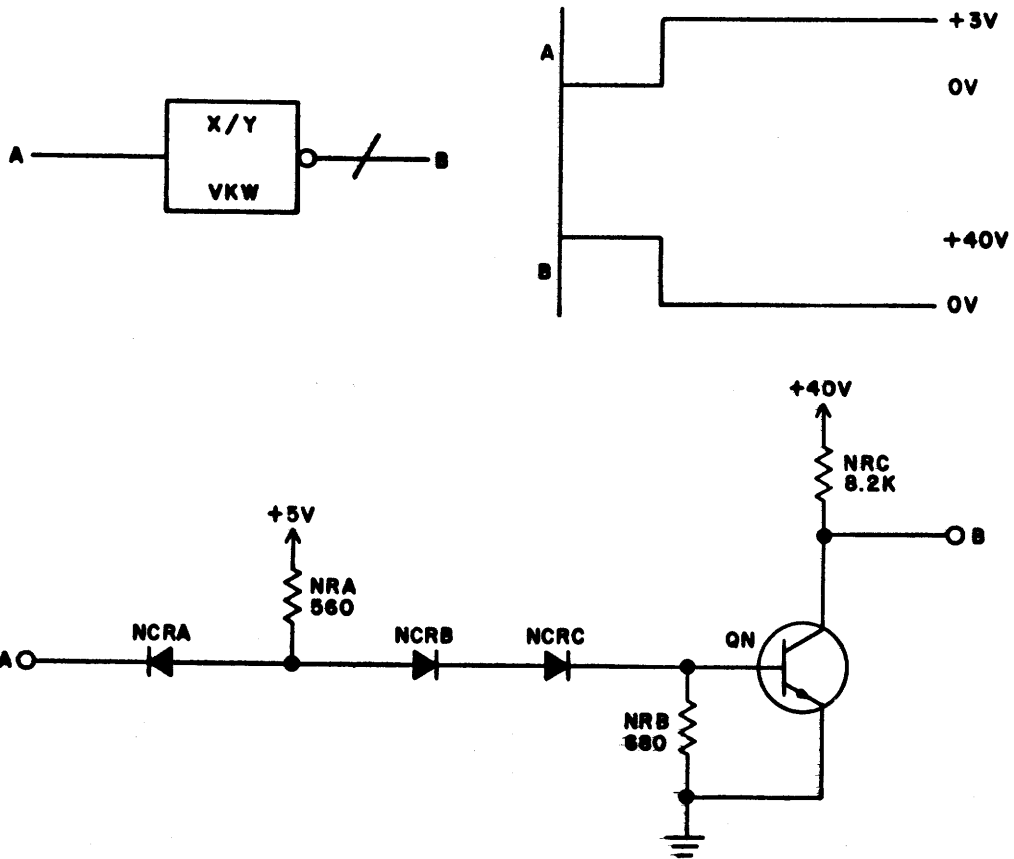

NOTE: VOLTAGE AND COMPONENT VALUES ARE FOR REFERENCE ONLY. 7K26

Figure 7-63.7. Level Translator - VKW

Level Translator - VKW

The VKW circuit converts a logic "0" to a +40v (nominal) level used in the write circuitry. When a logic "1" is present at input A, transistor QN saturates and the output goes to 0v.

Flip-Flop-WBB

The WBB circuit (Figure 7-64) is a toggle flip-flop with gate and data inputs.

Input B holds both transistors off by grounding the bases when the circuit is off. When a write operation is to be performed, the base of QP is released while QN is still grounded by input C. This sets an initial condition for the flip-flop: QP is on, QN is off.

After the flip-flop is pre-set, it is toggled through input A by a series of negative data pulses. The leading edge of the negative data pulse begins charging capacitor CNB. Diode CRND becomes forward biased. QP is on. Output E is at ground. A voltage of -3.6v across Zener diode CRNK keeps CRNN reverse biased. CRNK and CRNM clamp the output of QN at -3.8v.

The trailing edge of the data pulse results in a positive pulse to the base of QP. Transistor QP turns off. Output E goes toward -4v. Both sides of CNA are at ground. Therefore, CRNC and CRNF are forward biased by the -20v source through RNC. The base of QN goes negative. Transistor QN turns on and output D drops to ground. Diodes CRNM and CRNJ are now reverse biased. Since the collector of QP is more negative than the voltage across Zener diode CRNK (-3.6v), CRNN is forward biased. This clamps the voltage at output E at approximately -3.8v.

The leading edge of the next negative pulse charges CNA and discharges CNB since both sides of CNB are at about -3.8v. The flip-flop will toggle on the ground-going edge of the pulse in the same manner as described for the first pulse.

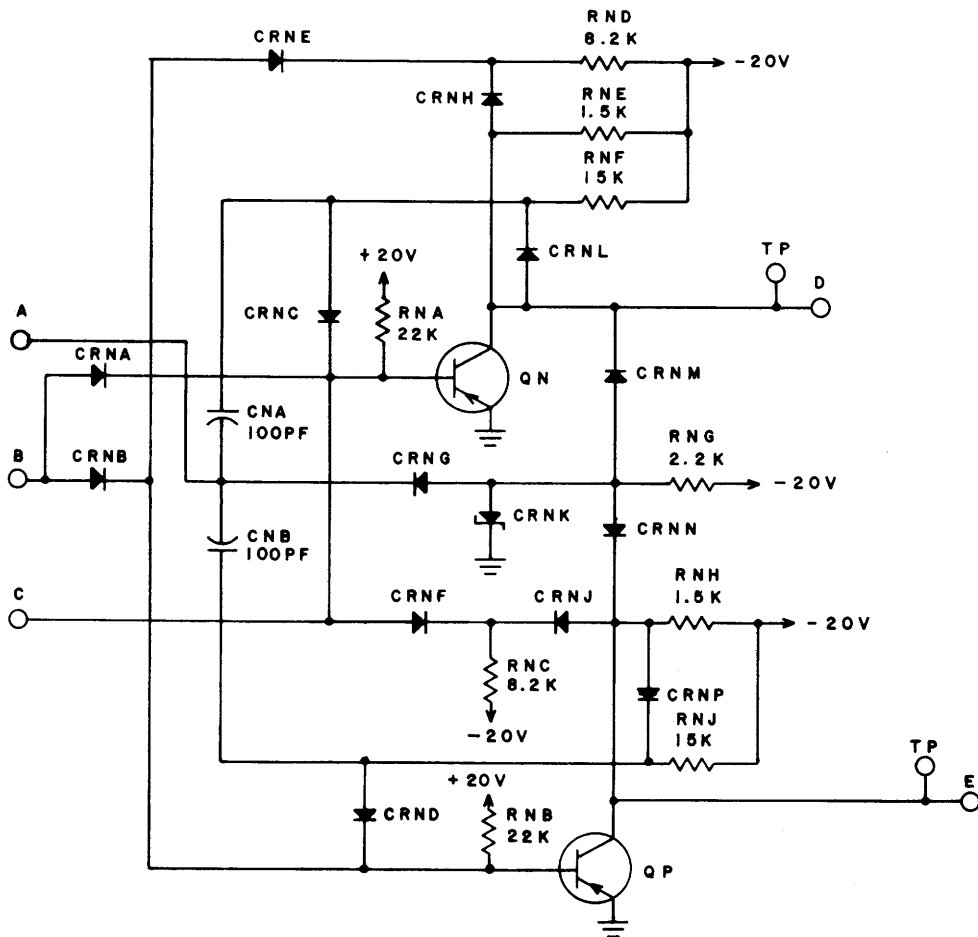
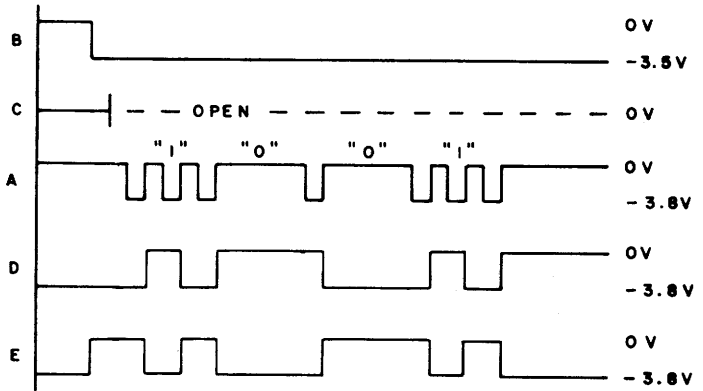
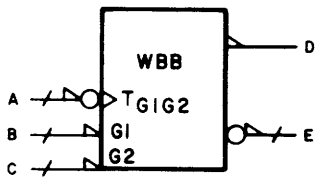

NOTE: VOLTAGE AND COMPONENT VALUES ARE FOR REFERENCE ONLY.

6T127

Figure 7-64. Flip-Flop - WBB

Toggle Flip-Flop - WBC

Inputs to A and B of the WBC flip-flop (Figure 7-65) are either a positive pulse or ground. If A has positive pulse, then B is at ground. If A is at ground then B has a positive pulse. If input A receives a positive pulse, output C will be at ground and output D will be a constant positive voltage. A positive pulse at B will toggle the flip-flop. C will then be a positive voltage and D will be at ground.

A positive pulse to input A turns on transistor QN, which drives the base of QR to ground. Transistor QR is turned off. Input B is at ground and QP is off. The base of QQ is, therefore, positive and QQ turns on. This latches the base of QR at ground and puts a ground on output C. With QP off and QR latched off, current flows from the +20v source through RNB to output D.

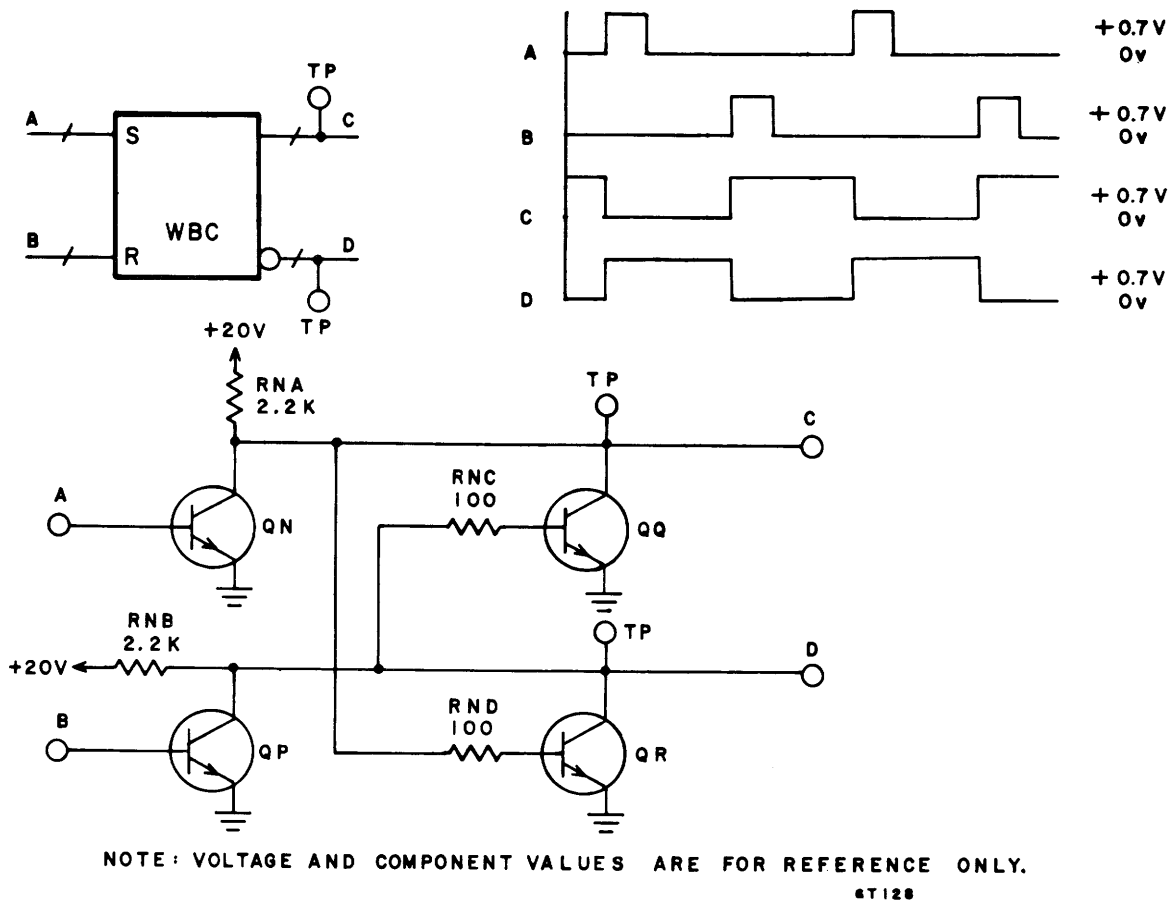

Figure 7-65. Toggle Flip-Flop - WBC

When a positive pulse is felt at B, QP turns on. This drives the base of QQ to ground, turning QQ off. Input A is at ground and QN is off. The base of QR is, therefore, positive. Transistor QR conducts, latching the base of QQ at ground and driving output D to ground. With QN and QQ off, output C is positive.

Single Shot - XAA

The input to A and B (Figure 7-66) of the XAA circuit is a 0.7v balanced square wave centered around a positive voltage. Each time the inputs change polarity a short negative pulse is formed at output C.

The square wave input is sufficient to alternately turn QN and QQ on and off. A current of about 5.6 ma is alternately switched between QN and QQ. When input A is more positive than input B, QN turns off. The voltage at the collector of QN is about -20v. The voltage at the junction of RNG and RNJ is -1.6v. When the inputs switch, QN turns on. The collector of QN rises to about -8.7v. CNA forms a positive pulse to the base of QR. The positive pulse turns QR off, QT on and QV off for the duration of the pulse. The amplitude of the pulse is limited by CRNB. Charging time for CNA is about 100 nsec. When the inputs switch again, QQ turns on and QN turns off. CNB forms a positive pulse which turns QV off again for the duration of the pulse. The output at C is ground until QV is turned off. During the short time that QV is off, a negative pulse appears at output C.

Diodes CRND and CRNE prevent saturation of QR and QS. As the collectors of QR and QS approach ground, the negative voltage at the left ends of RNJ and RNK is limited to the sum of the voltage drops across QR and CRND or QS and CRNE, respectively. Diode CRNF prevents QV from saturating.

Single Shot - XAB

The input at A of the XAB circuit (Figure 7-67) is a balanced square wave between 0v and +0.75v. The output at B is normally positive, but drops to ground for a short time at the leading edge of the ground portion of the input wave.

During the positive portion of the input wave, transistors QN and QP are on. This leaves the bases of QQ and QR near ground. Transistors QQ and QR are off. The output at B is a positive voltage supplied through resistor RNE.

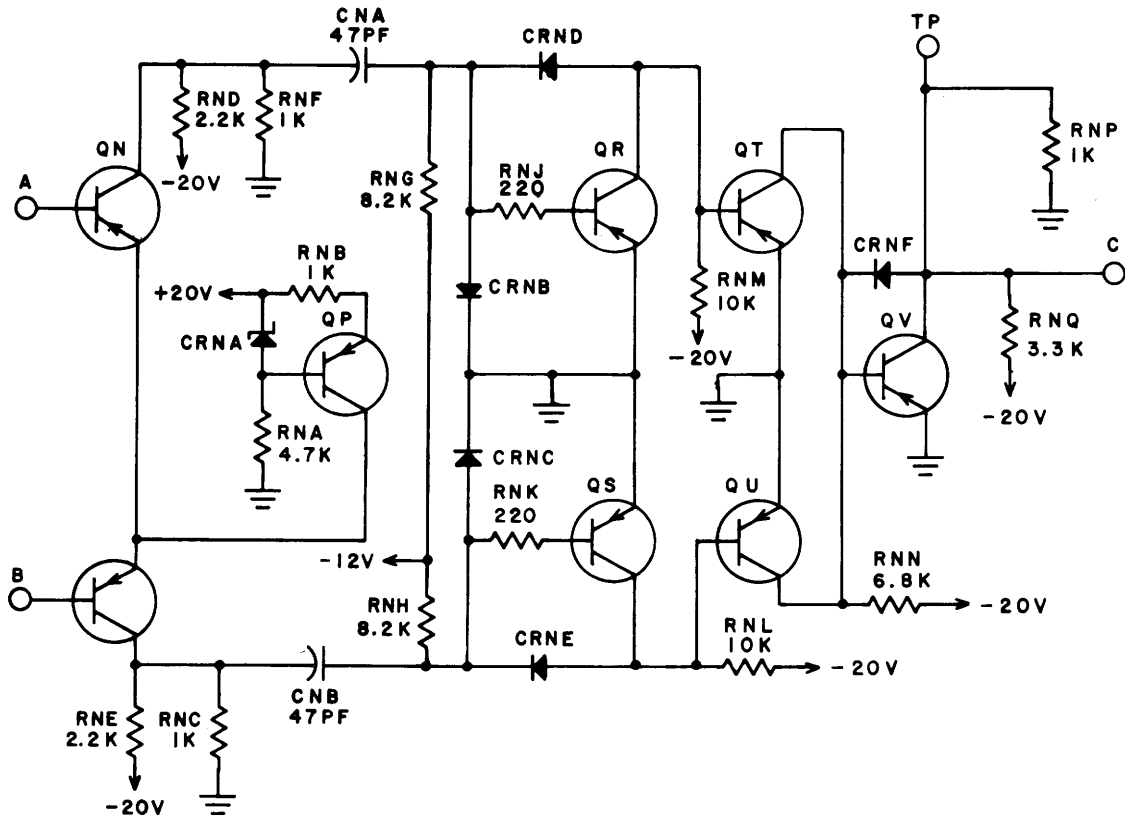
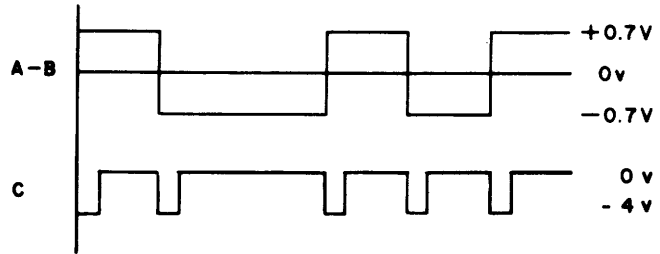
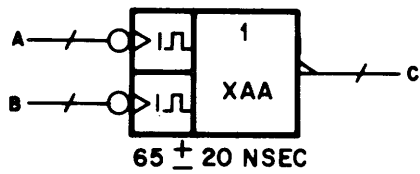

NOTE: VOLTAGE AND COMPONENT VALUES ARE FOR REFERENCE ONLY.

6T129

Figure 7-66. Single Shot - XAA

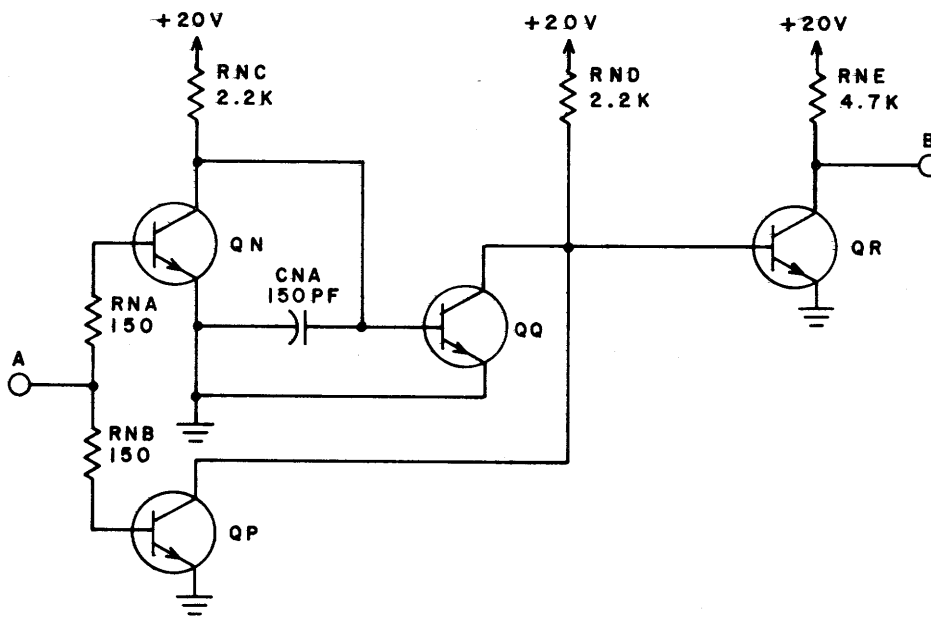
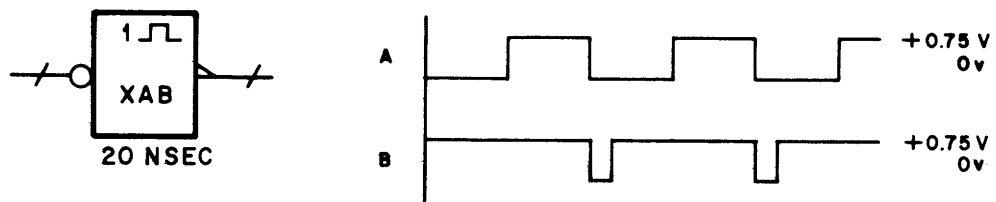

NOTE: VOLTAGE AND COMPONENT VALUES ARE FOR REFERENCE ONLY.

6T130

Figure 7-67. Single Shot - XAB

When the input wave goes to ground, transistors QN and QP turn off. With QP off, the base-emitter junction of QR is forward biased. Transistor QR conducts and the output at B drops to near ground. With QN off, capacitor CNA charges toward +20v. When the charge on CNA reaches a level sufficient to turn on QQ, the base of QR again drops to ground. Transistor QR turns off. The output at B returns to the positive level.

Gated Single Shot - XAC

The XAC circuit (Figure 7-68) produces a 100-nsec ground pulse at output C when the inputs at A and B change state. The output is normally positive. Input A is connected to the set side of a flip-flop and input B is connected to the clear side.

When the flip-flop is clear, the base of QR is positive. Transistor QR conducts 10 ma of current from the -20v supply through RND, RNC, QS, QR and RNB. The collector of QN is at +20v and the collector of QR is near +13v. Transistors QT and QU are on and QV and QW are off.

When the flip-flop sets, QR turns off and QN turns on. The collector of QN goes to +13v, which drives the base of QT to about -6v. This turns QT off, driving the base of QV positive. QV turns on and the output at C goes to ground. Capacitor CNA charges through RNE with a time constant of 135 nsec. After 100 nsec the voltage at the base of QT has risen to +0.7v and QT turns on. This drives the base of QV to ground. QV turns off and the output at C returns to a positive level.

When the flip-flop clears again, a 100-nsec ground pulse is formed at C by QR, CNB, QU and QW.

Single Shot - XAE

The XAE circuit (Figure 7-69) is a combination inverter and pulse shaper. The circuit monitors the voltage fluctuations across the head write coils. Its output is used to detect the occurrence of a fault during a write operation.

Inputs A and B are connected across the center-tapped (to ground) pair of write coils. As write current changes polarity, a negative pulse from the undriven coil momentarily turns on QN. When QN turns on, capacitor NC1 discharges through the base of QP. Transistor QP is already on, so the discharge causes it to draw more current. As the write current polarity changes, QN turns off and NC1 charges to -5 volts via diode NCR1 and resistor NR2. This action momentarily provides reverse bias to QP and turns it off for 50 nanoseconds to

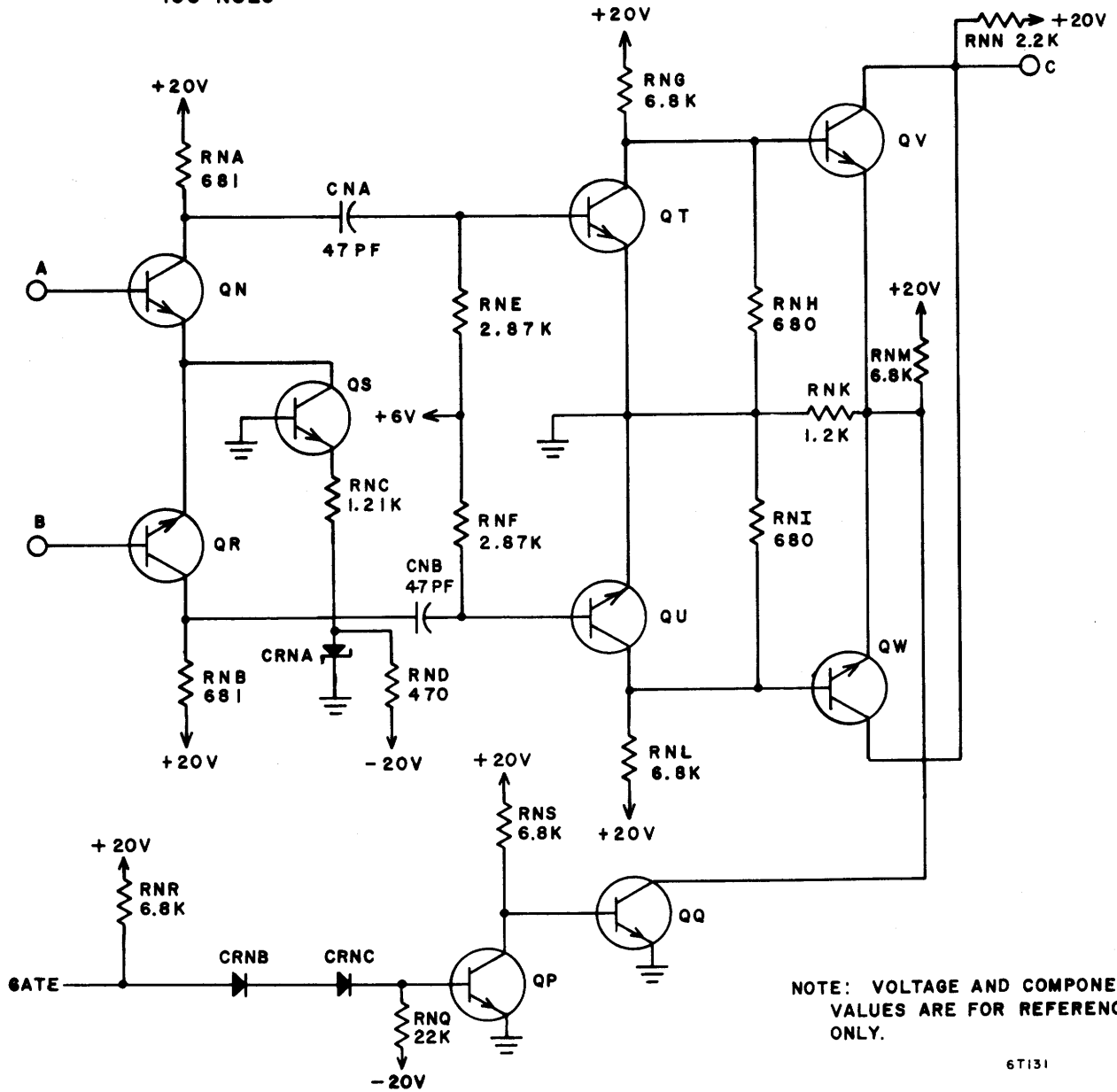
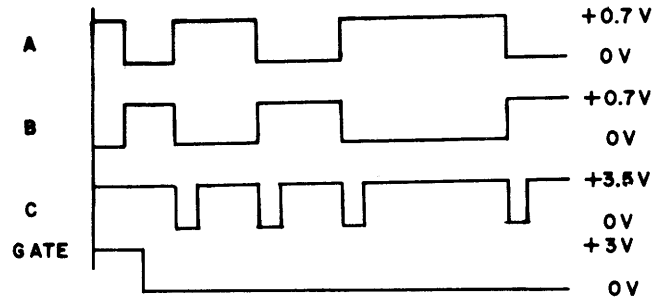
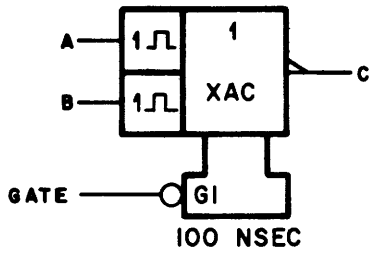

6T131

Figure 7-68. Gated Single Shot - XAC

cause a positive pulse at output D. A pulse appears at D for each transition of the head write current. The pulses drive a single-shot IC circuit which, if allowed to time out, will signal a fault.

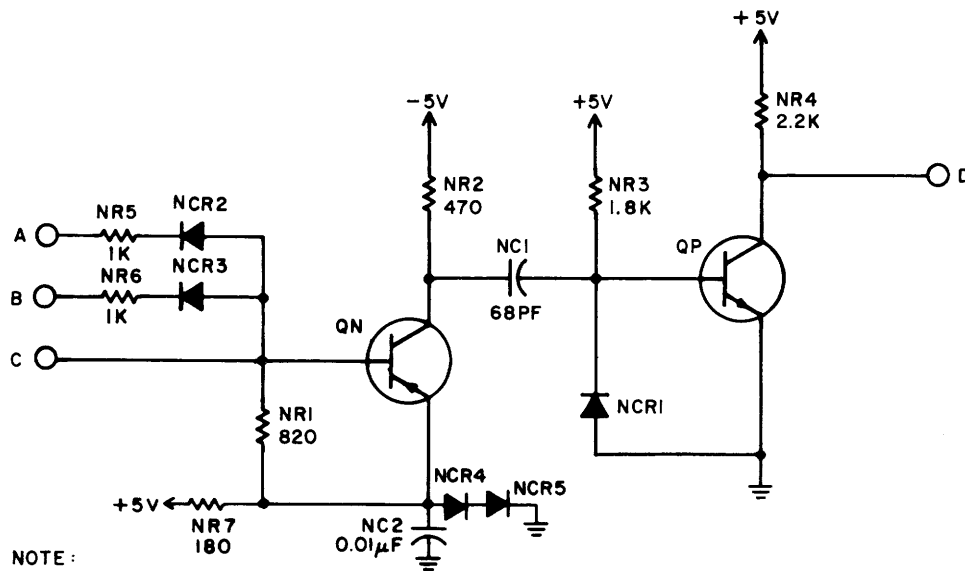
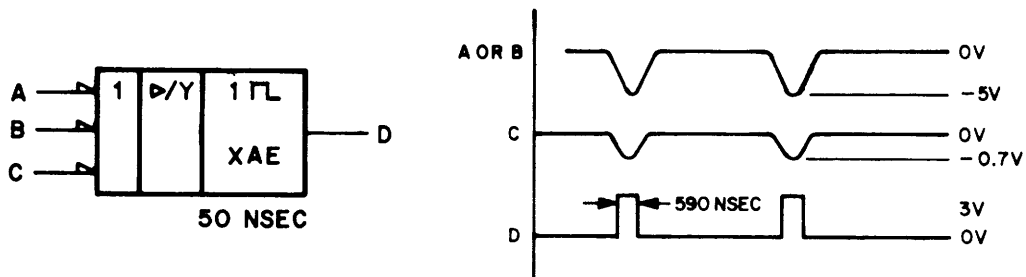

NOTE :

I. VOLTAGE AND COMPONENT VALUES FOR REFERENCE ONLY

6T150

Figure 7-69. Single Shot - XAE

PART 2

CARD DIAGRAMS



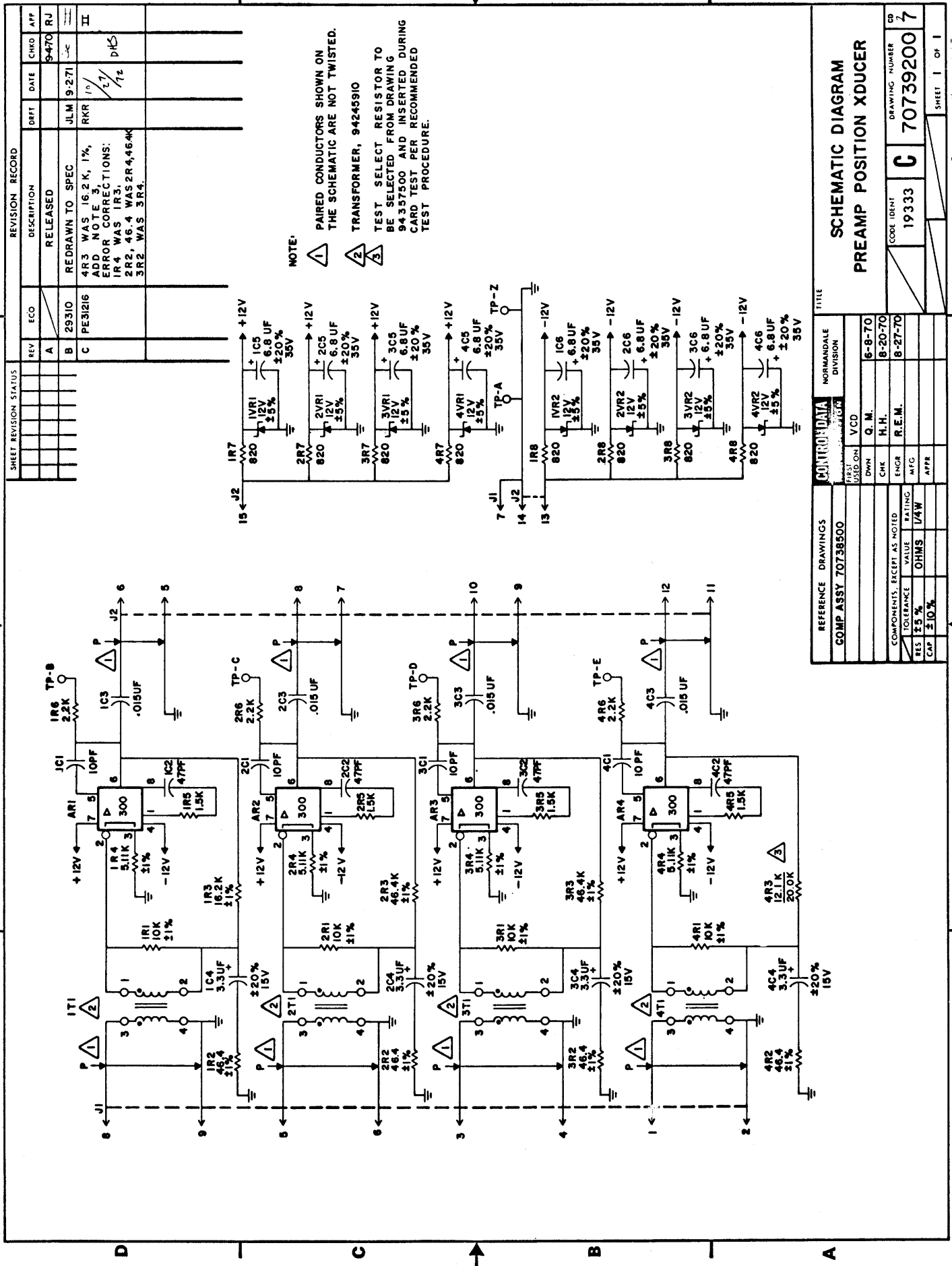

NOTE:
 1 PAIRED CONDUCTORS SHOWN ON THE SCHEMATIC ARE NOT TWISTED.
 2 TRANSFORMER, 94245910
 3 TEST SELECT RESISTOR TO BE SELECTED FROM DRAWING 6 94357500 AND INSERTED DURING CARD TEST PER RECOMMENDED TEST PROCEDURE.

SHEET REVISION STATUS		REVISION RECORD	
REV	ECO	DESCRIPTION	DRFT
A	29310	RELEASED	JLM 9-271
B	PE31216	REDRAWN TO SPEC	RKR 10/12
C		4R3 WAS 16.2K, 1%, ADD NOTE 3, ERROR CORRECTIONS: IR 4 WAS IR3, 2R2, 46.4 WAS 2R4, 46.4K 3R2 WAS 3R4.	

REFERENCE DRAWINGS		CONTROL DATA		NORMAN DALE	
COMP ASSY 70739200		USED ON	VCD	DIVISION	
CHK	Q. M.	DWN	6-8-70		
ENGR	H. H.	ENGR	8-20-70		
RES	15%	APPR	8-27-70		
CAP	±10%				

TITLE
SCHEMATIC DIAGRAM
PREAMP POSITION XDUCER

CODE IDENT	19333	DRAWING NUMBER	70739200
CD	C		7

70739200

SHEET REVISION STATUS		REVISION RECORD		CHKD	APP
REV	ECO	DESCRIPTION	DATE		
A	533200	RELEASED			II
B	PE31216	4R3 WAS 46.4K, 1%. ADD NOTE 3. ERROR CORRECTIONS: IR4 WAS IR3. 2R2, 46.4 WAS 2R4, 46.4K 3R2 WAS 3R4	RKR 1/27/72		DHS

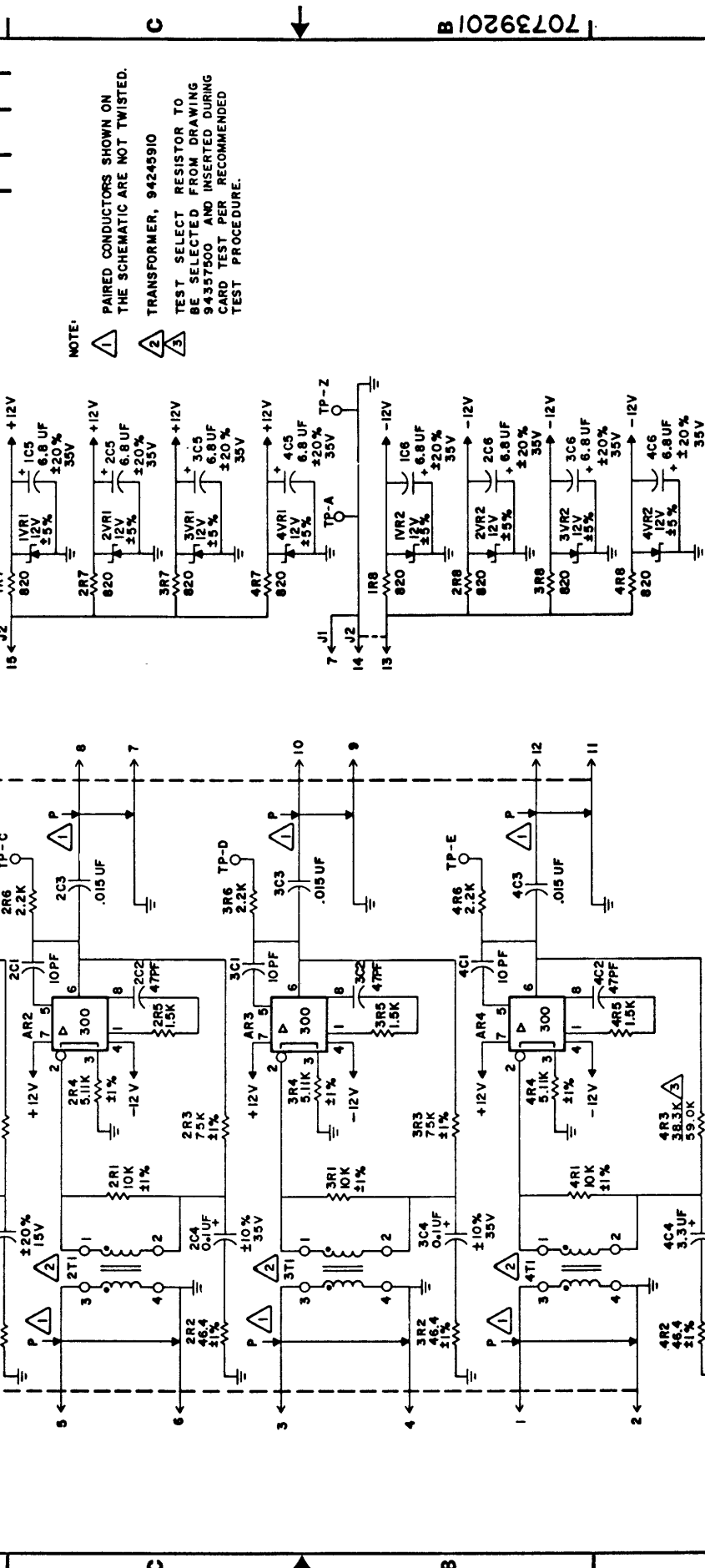

NOTE:

- 1 PAIRED CONDUCTORS SHOWN ON THE SCHEMATIC ARE NOT TWISTED.
- 2 TRANSFORMER, 94245910
- 3 TEST SELECT RESISTOR TO BE SELECTED FROM DRAWING 94357500 AND INSERTED DURING CARD TEST PER RECOMMENDED TEST PROCEDURE.

REFERENCE DRAWINGS	CONTROL DATA	NORMANDEALE DIVISION
COMP ASSY 70739201	BRSAIA	
	USED ON	R. KONECNY 10/2/71
	OWN	H. 10-5-71
	ENGR	R. OPTIC 10/5/71
	MFG	D. PAGES/L.B. 10-6-71
	APPR	A.B. 10-6-71

TITLE
SCHEMATIC DIAGRAM
PREAMP POSITION XDUCER

COR IDENT	19333	DRAWING NUMBER	70739201	CD	5
SHEET 1 OF 1			YCD		

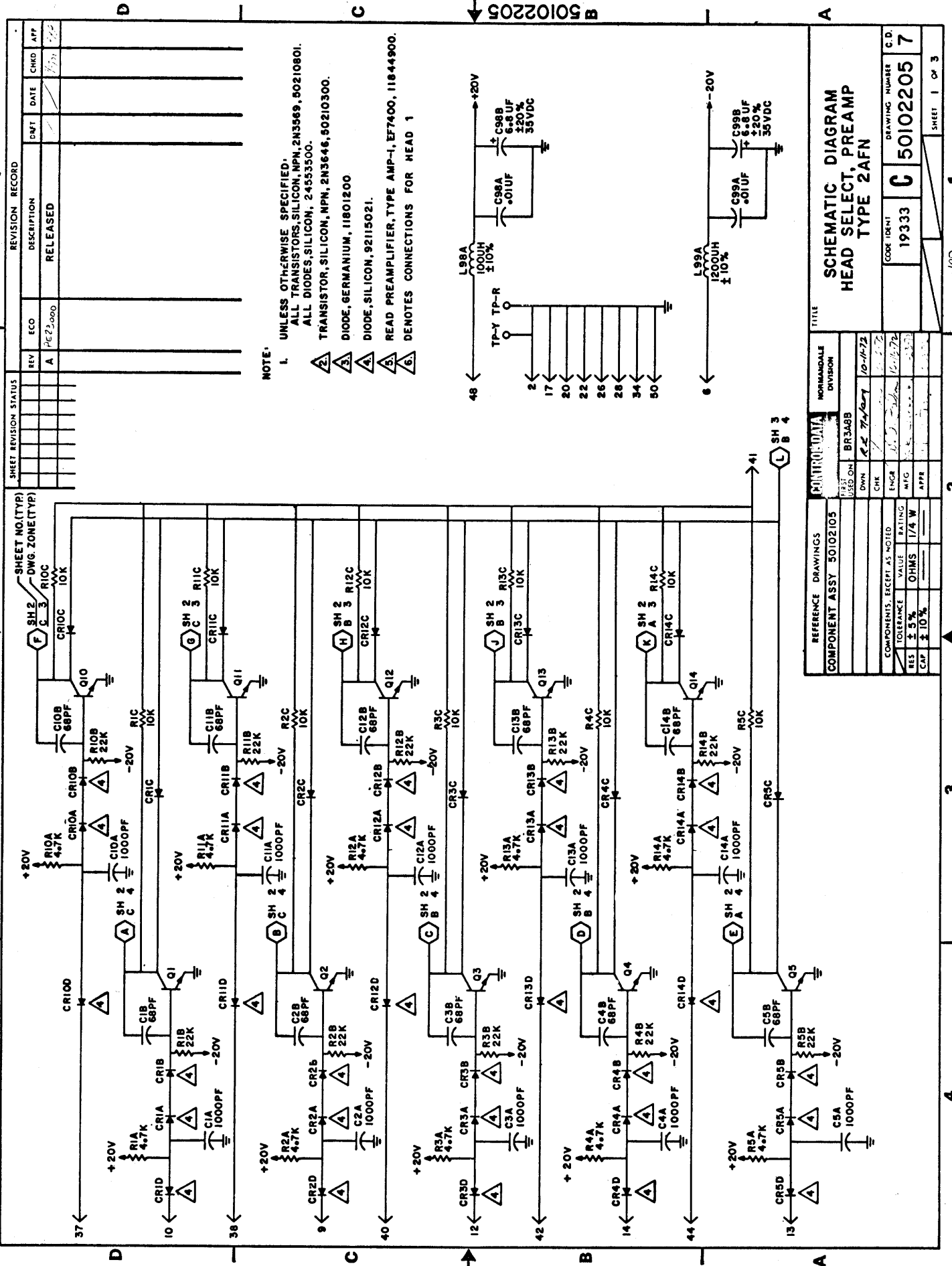

NOTE:

- 1. UNLESS OTHERWISE SPECIFIED:
ALL TRANSISTORS: SILICON, NPN, 2N35589, 50210801.
ALL DIODES: SILICON, 24553500.
- 2. TRANSISTOR, SILICON, NPN, 2N3646, 50210300.
- 3. DIODE, GERMANIUM, 11801200
- 4. DIODE, SILICON, 92115021.
- 5. READ PREAMPLIFIER, TYPE AMP-1, EF7400, 11844900.
- 6. DENOTES CONNECTIONS FOR HEAD 1

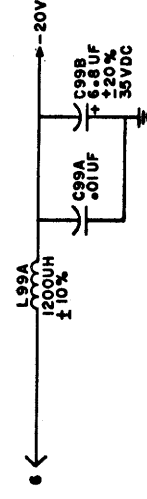
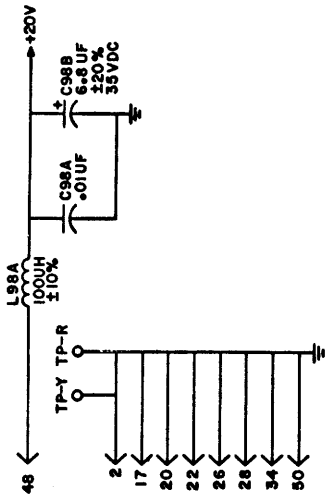

SHEET REVISION STATUS		REVISION RECORD			
REV	ECO	DESCRIPTION	DATE	CHKD	APP
A	10-23-5000	RELEASED			

REV	ECO	DESCRIPTION	DATE	CHKD	APP

REFERENCE DRAWINGS		NORMANDALE DIVISION	
TEST	USED ON	CHK	DATE
	BR3AB8		
	10-11-72		
	11-13-72		

COMPONENT ASSY 50102105		DRAWING NUMBER	
RES	OHMS	19333	50102205

SCHEMATIC DIAGRAM		DRAWING NUMBER	
HEAD SELECT, PREAMP		50102205	
TYPE 2AFN		7	

CODE IDENT: 19333
DRAWING NUMBER: 50102205
SHEET 1 OF 3

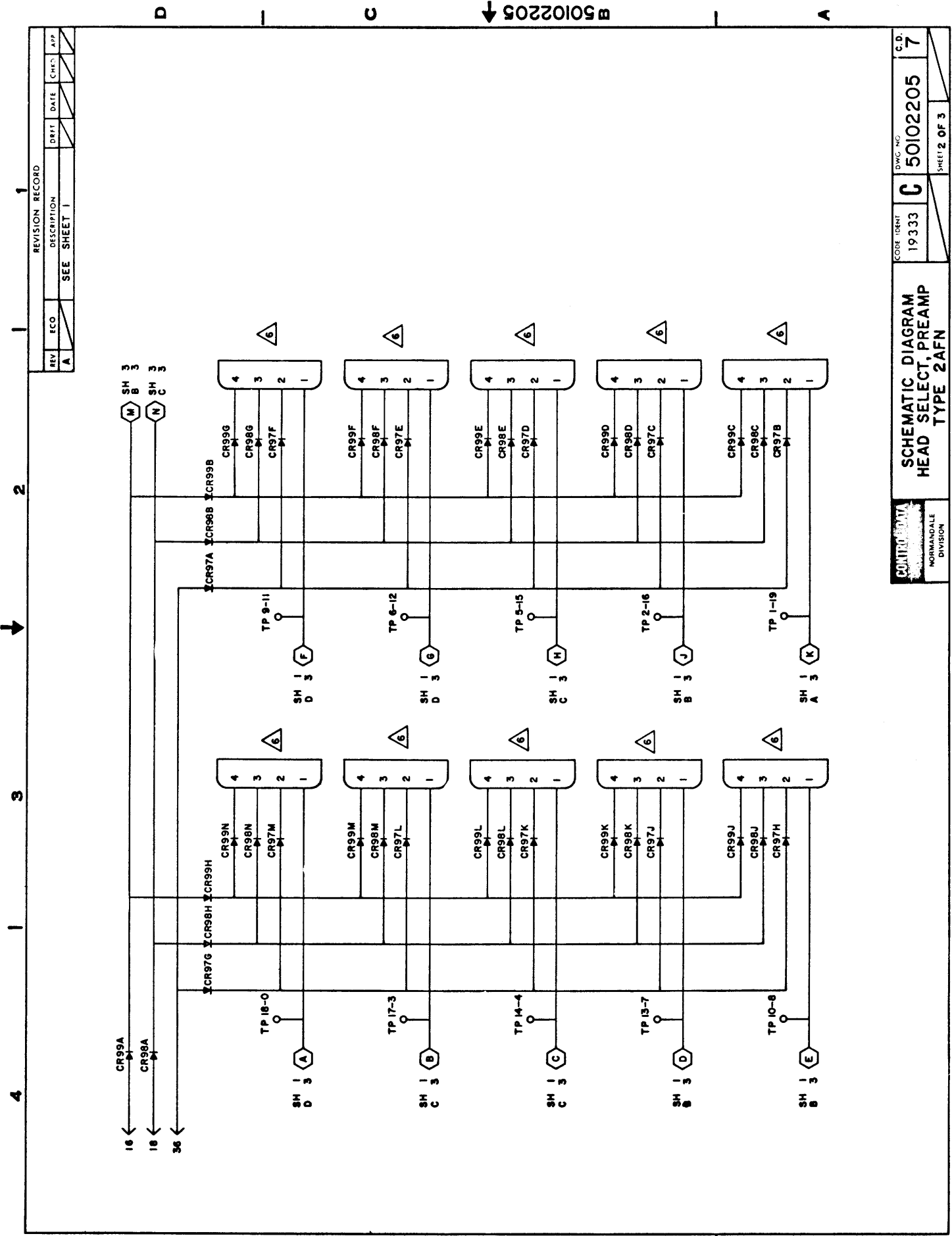

B 50102205 ↓

↑

↑

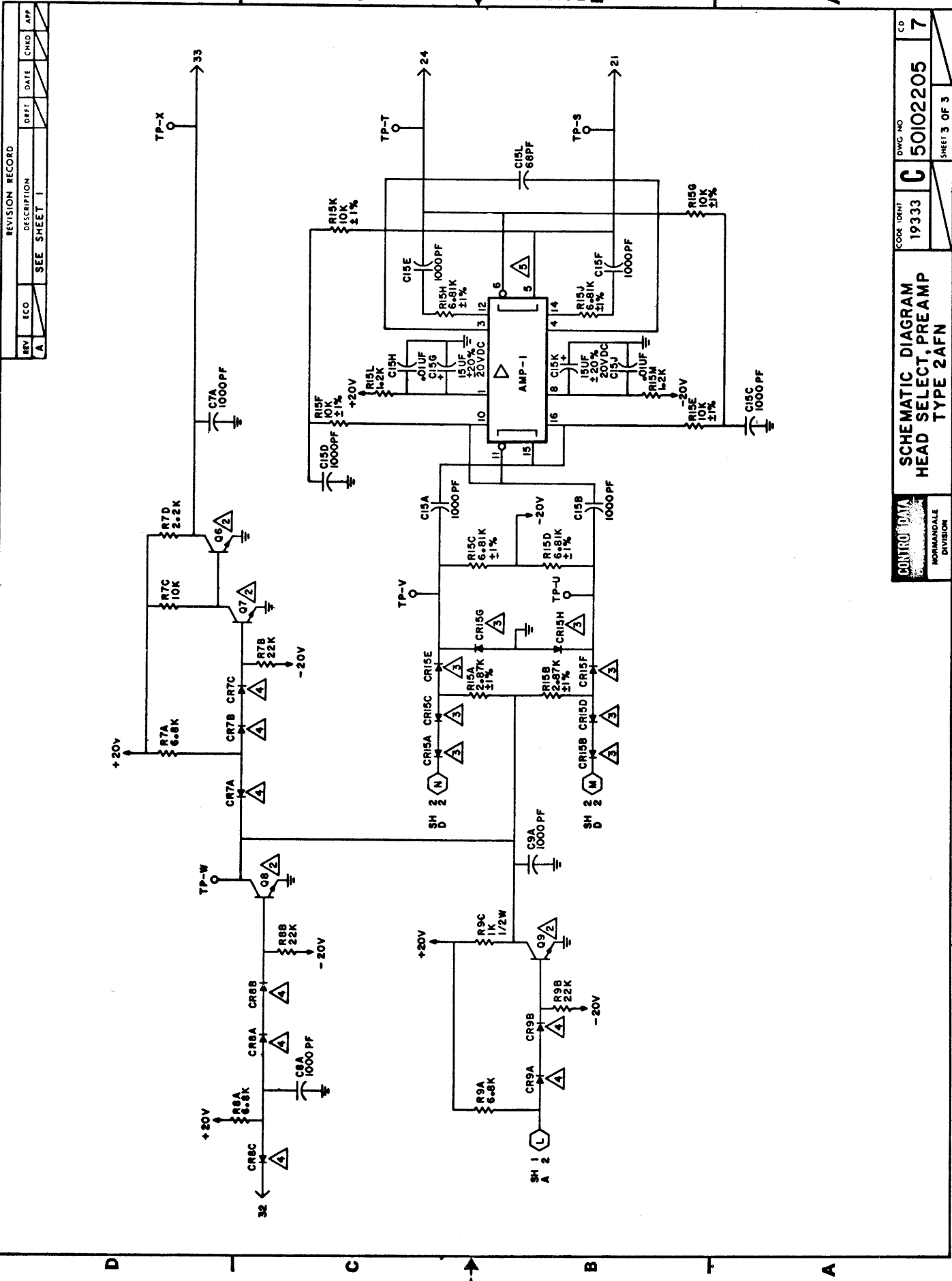

REVISION RECORD			
REV	ECO	DESCRIPTION	DATE
A		SEE SHEET 1	

REV	ECO	DESCRIPTION	DATE	CHKD	APP

CONTROL DATA
NORMANDALE
DIVISION

SCHEMATIC DIAGRAM
HEAD SELECT. PREAMP
TYPE 2AFN

CODE IDENT 19333

DWG NO C 50102205

CD 7

SHEET 3 OF 3

50102205

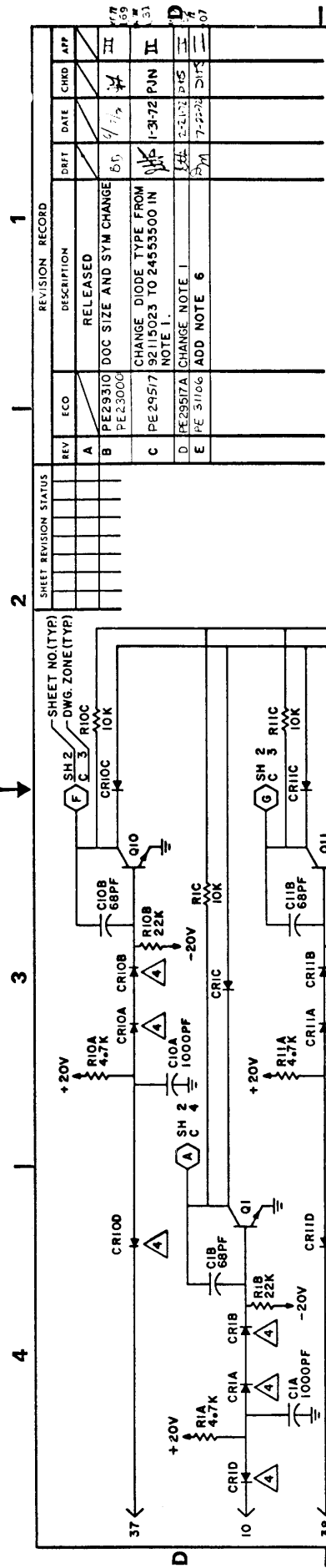

NOTE:

- UNLESS OTHERWISE SPECIFIED:
ALL TRANSISTORS, SILICON, NPN, 2N3569, 50210801.
ALL DIODES, SILICON, 2453500.
- TRANSISTOR, SILICON, NPN, 2N3646, 50210300.
- DIODE, GERMANIUM, 11801200.
- DIODE, SILICON, 92115021.
- READ PREAMPLIFIER, TYPE AMP-1, EF7400, 11844900.
- ⊿ DENOTES CONNECTIONS FOR HEAD 1

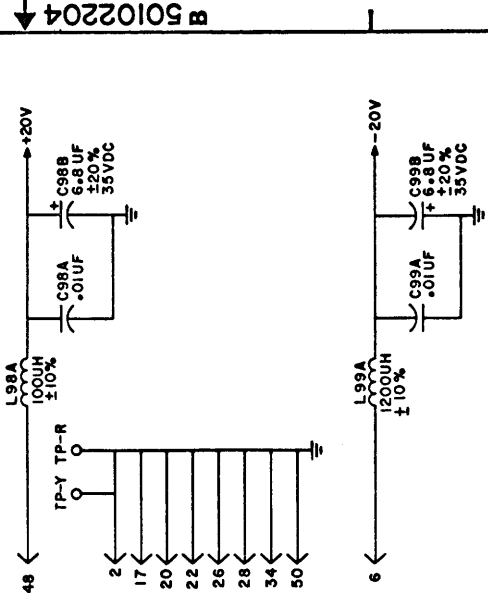

SHEET REVISION STATUS		REVISION RECORD			
REV	ECO	DESCRIPTION	DATE	CHD	APP
A	PE29310	RELEASED	85		III
B	PE29310	DOC SIZE AND SYM CHANGE	85		III
C	PE29517	CHANGE DIODE TYPE FROM 92115023 TO 24555500 IN NOTE 1.	1-31-72		II
D	PE29517A	CHANGE NOTE 1	2-21-72		II
E	PE 51106	ADD NOTE 6	7-27-72		II

REFERENCE DRAWINGS		CONTROL DATA		NORMANDAILE DIVISION	
COMPONENT ASSY	50102104	DATE	BY	DATE	BY
RES	± 5%	CHK	D. [Signature]	5-24-72	
CAP	± 10%	ENGR	K. [Signature]	5-28-72	
TOLERANCE VALUE		MFG	[Signature]	7-20-72	
COMPONENTS, EXCEPT AS NOTED		APPR	[Signature]	8-27-72	

SCHEMATIC DIAGRAM		DRAWING NUMBER	
HEAD SELECT, PREAMP		C 50102204 0	
CODE IDENT	19333	SHEET	1 OF 3

REV	ECD	DESCRIPTION	DATE	APP
1		SEE SHEET 1		

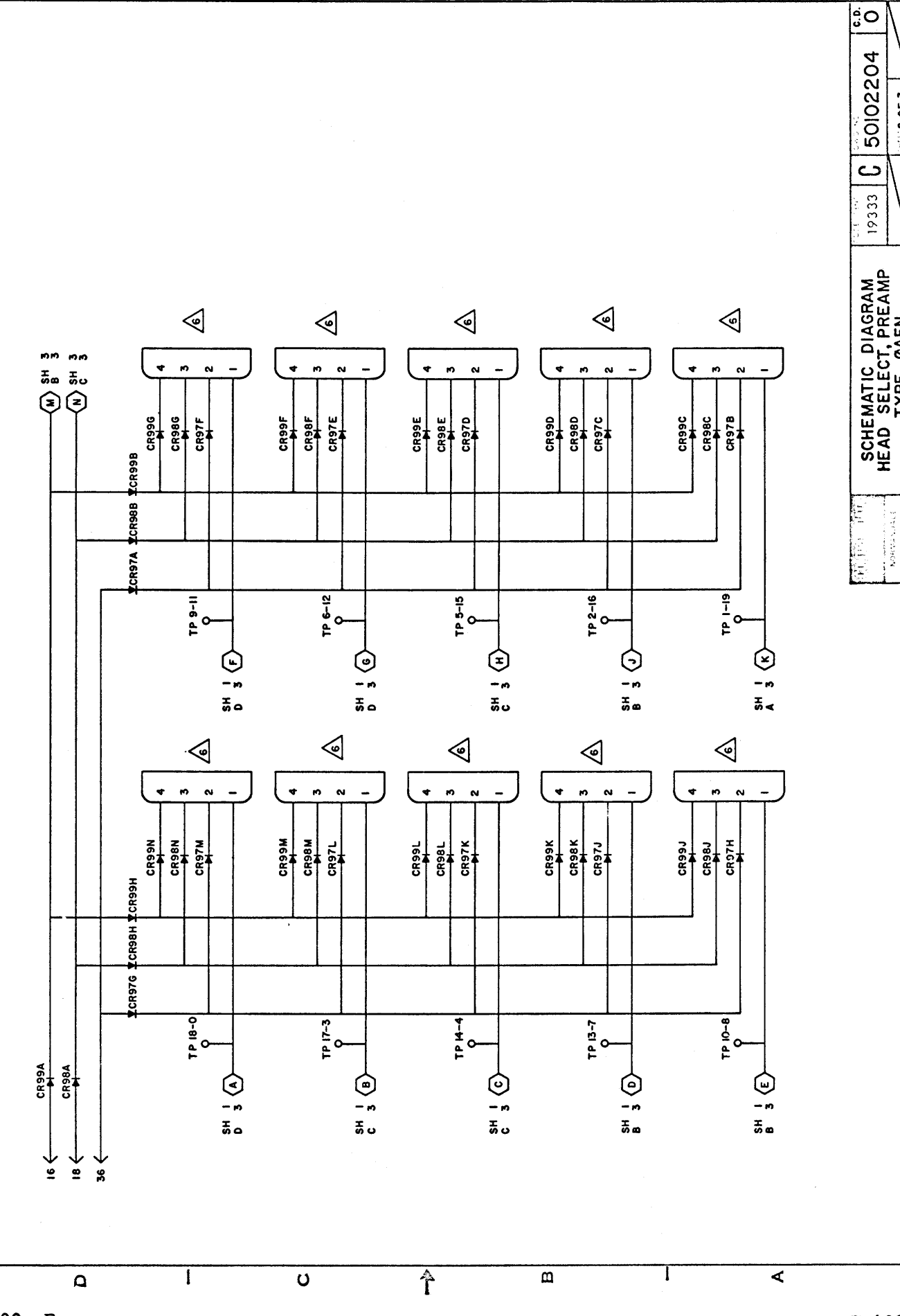

70616800 F

50102204

7-103

REVISION RECORD	DESCRIPTION	DATE	APP	
1	SEE SHEET 1			
SCHEMATIC DIAGRAM		19-333	C	50102204
HEAD SELECT, PREAMP				PAGE 2 OF 3
TYPE ØAFN				

1 2 3 4

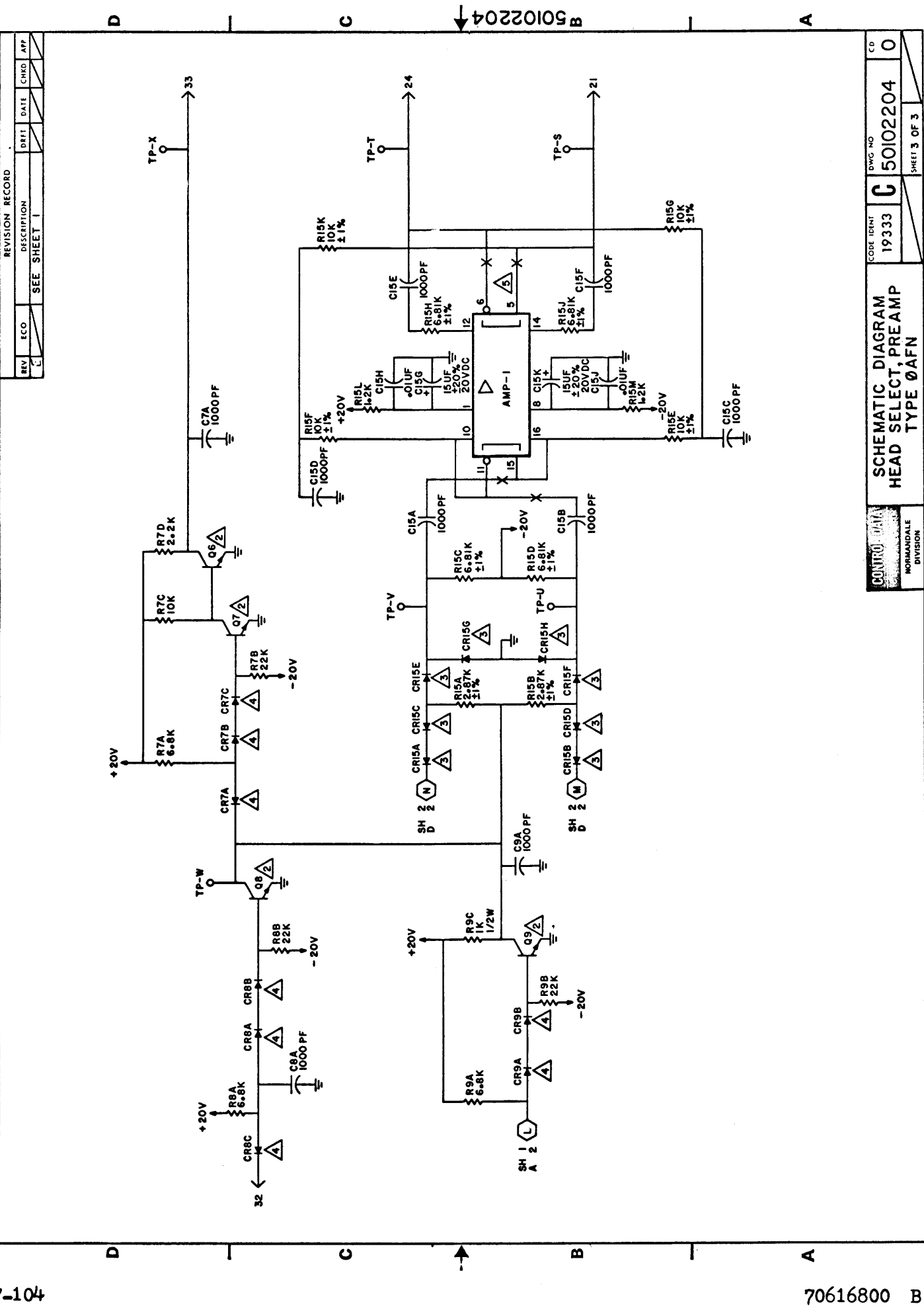

REV	ECO	DESCRIPTION	DATE	CHD	APP
		SEE SHEET 1			

REVISION RECORD		CODE	DATE	DWG NO	SHEET	OF

SCHEMATIC DIAGRAM		50102204	
HEAD SELECT, PREAMP		19333	
TYPE ØAFN		SHEET 3 OF 3	

1 2 3 4

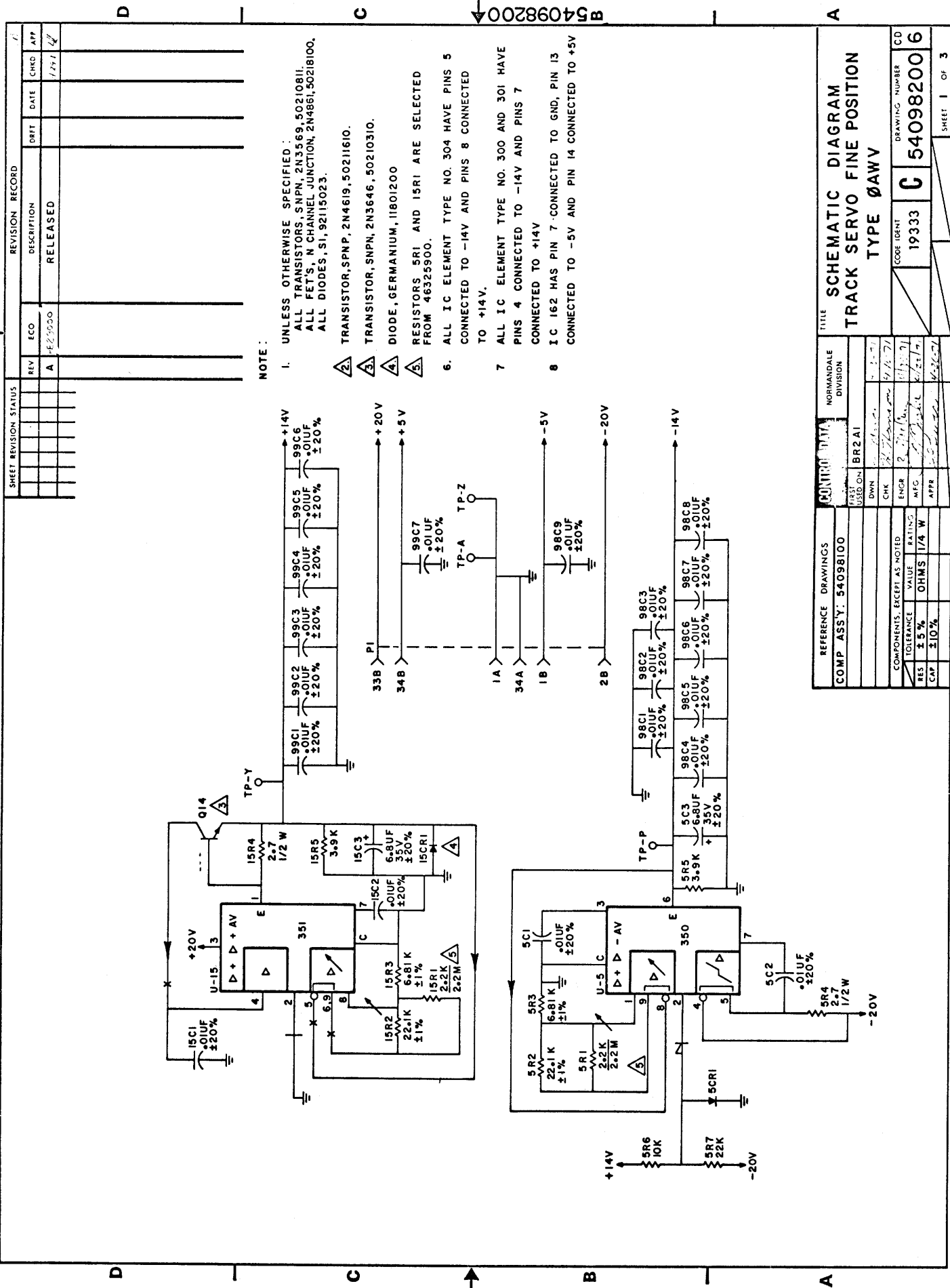

1
2
3
4

REVISION RECORD

REV	ECO	DESCRIPTION	DFT	DATE	CHKD	APP
A	142/1000	RELEASED				

SHEET REVISION STATUS

REV	ECO	DESCRIPTION	DFT	DATE	CHKD	APP

CONTROL DATA

REV	ECO	DESCRIPTION	DFT	DATE	CHKD	APP

REFERENCE DRAWINGS

COMP	ASSY	DRAWING NUMBER
	54098100	

NORMANDALE DIVISION

REV	ECO	DESCRIPTION	DFT	DATE	CHKD	APP

COMPONENTS, EXCEPT AS NOTED

TOLERANCE	VALUE	RATING
RES	±5%	OHMS 1/4 W
CAP	±10%	

TITLE

SCHMATIC DIAGRAM

TRACK SERVO FINE POSITION

TYPE ØAW

CODE IDENT

19333

DRAWING NUMBER

54098200

SHEET 1 OF 3

574098200

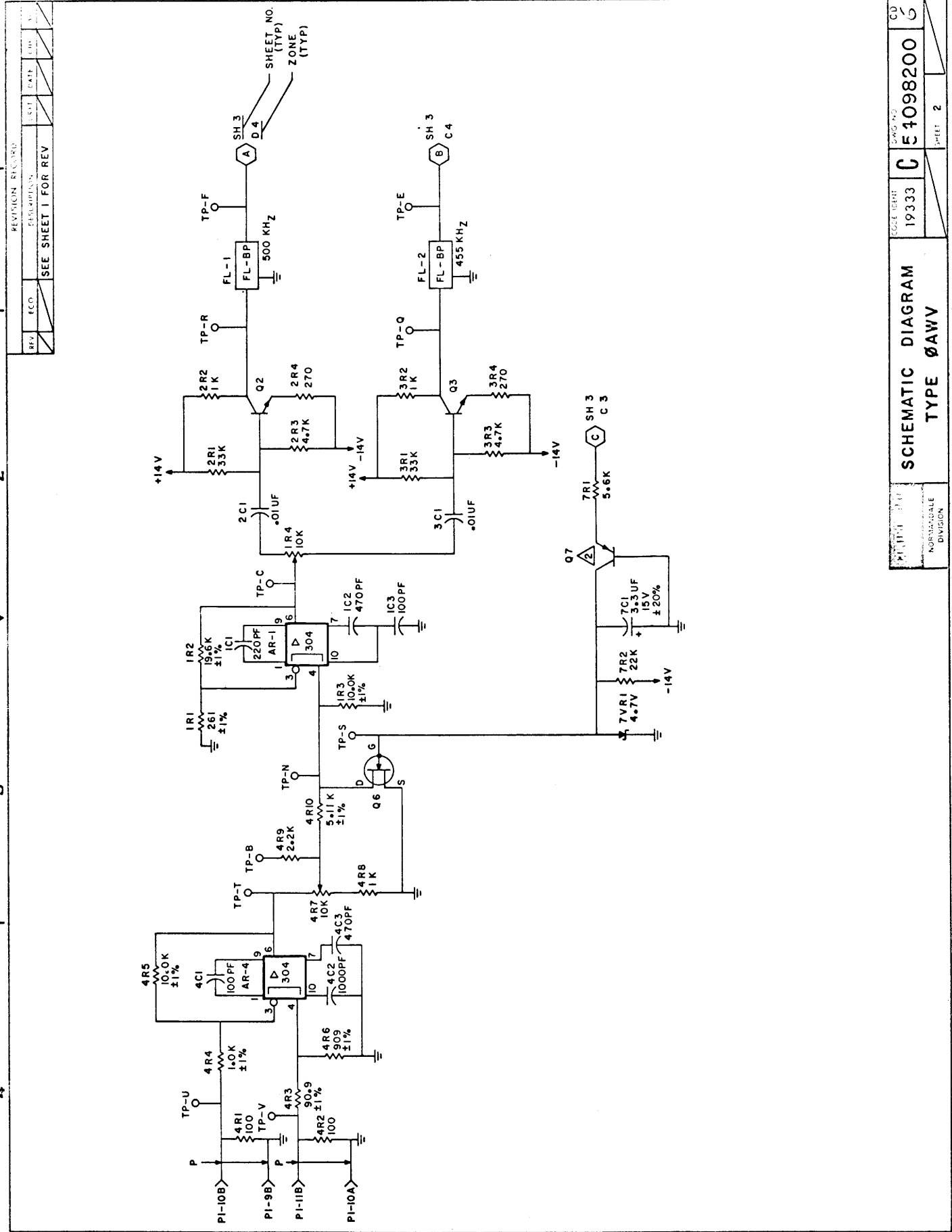

REV	ECO	SEE SHEET 1 FOR REV	DATE	CD
REVISION RECORD				
DESCRIPTION				
SHEET 1 FOR REV				
SHEET NO. 2				
SCHEMATIC DIAGRAM			CD	5
TYPE ØAWV			EDGE IDENT	19333
NORTHDAKOTA DIVISION			DWG NO	E1098200

W54098200

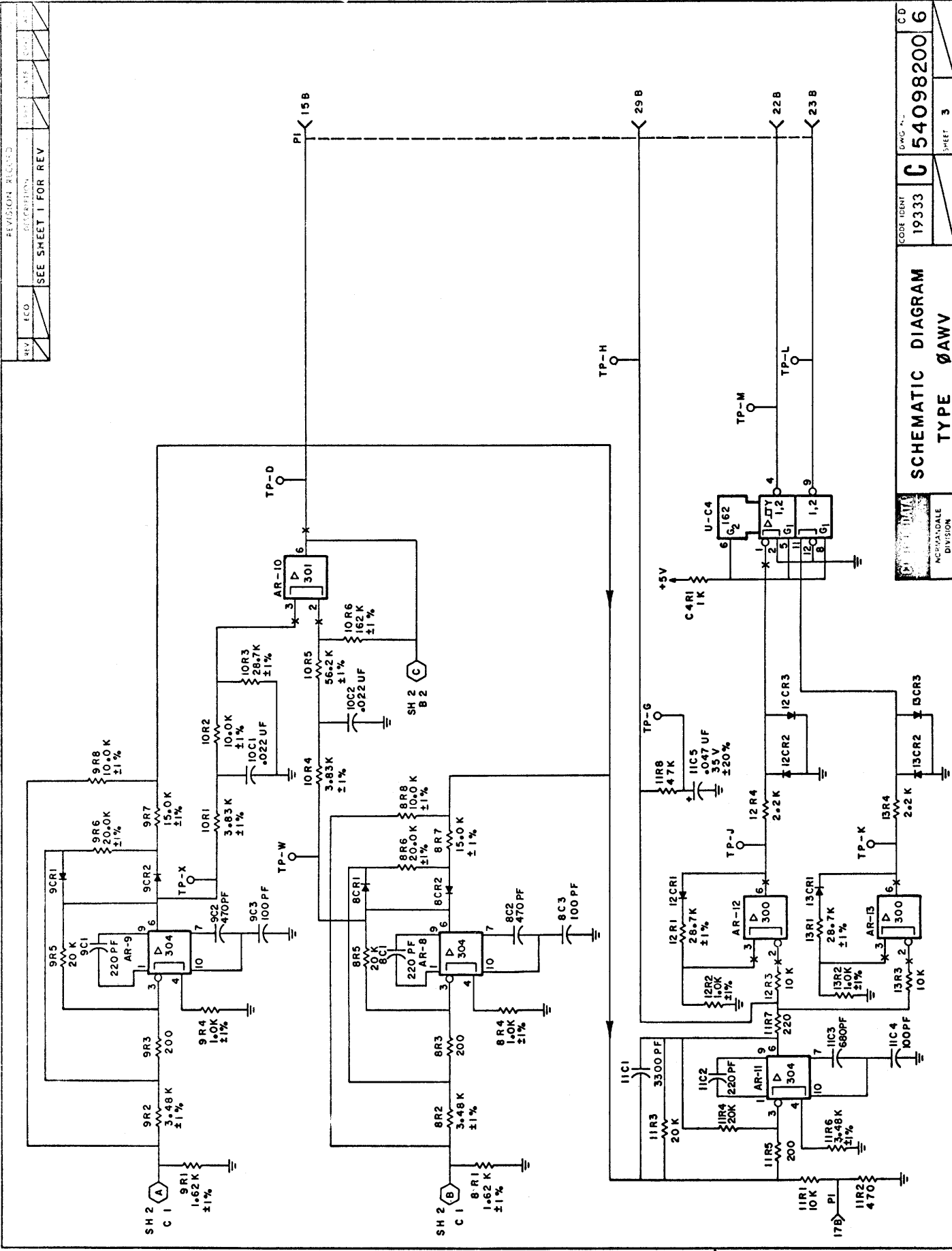

REV	ECO	DESCRIPTION	DATE	BY
SEE SHEET 1 FOR REV				

SCHEMATIC DIAGRAM
TYPE ØAW

CD 54098200 6
19333
19333
19333

REVISION RECORD

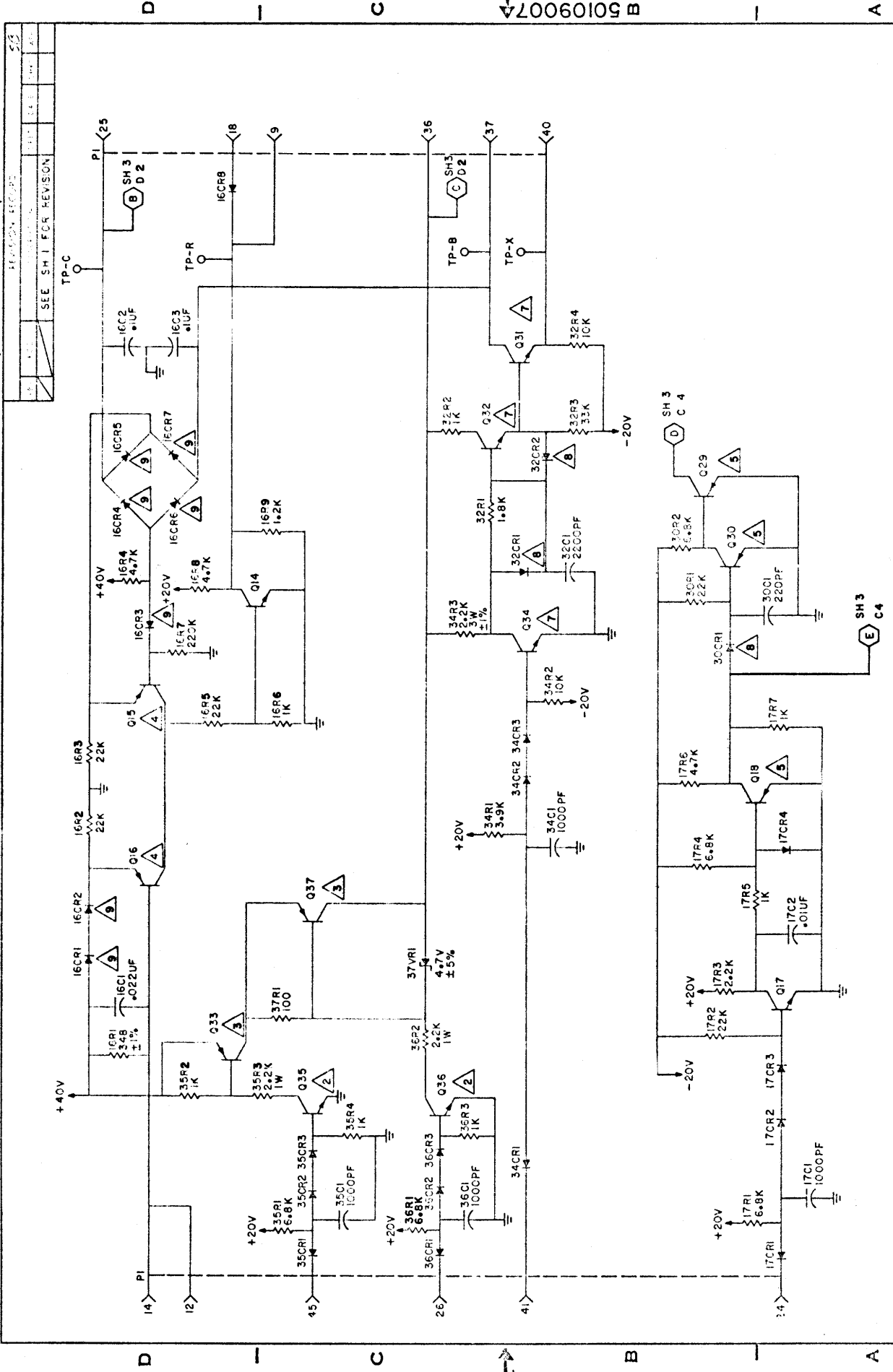

REV	ECC	DATE	APP
MISSION: SECURED			
SEE SH 1 FOR REVISION			

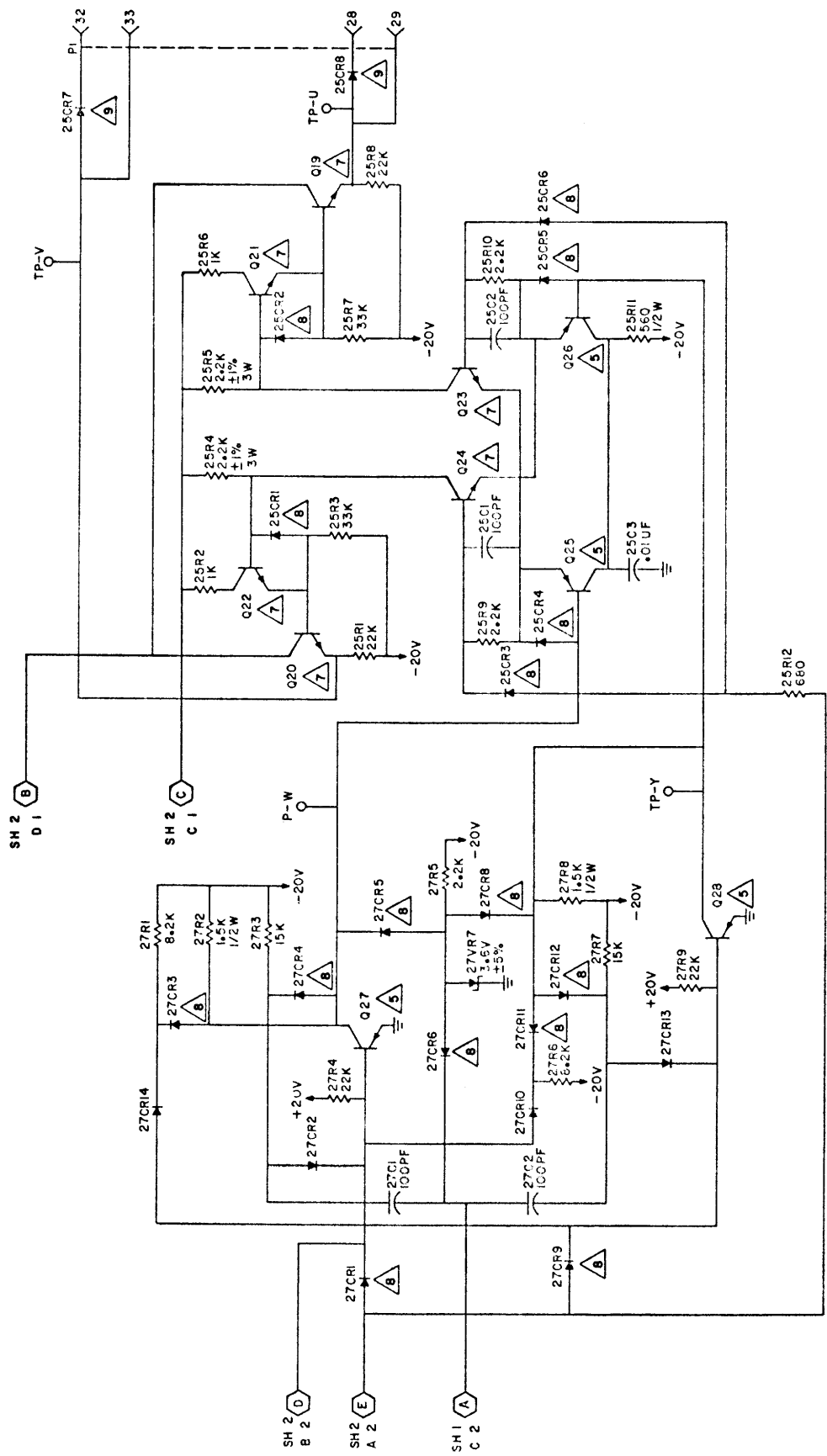

CD	50109007	0
1933	C	3
SCHEMATIC DIAGRAM		
WRITE ERASE CIRCUIT		
TYPE 1A1N		

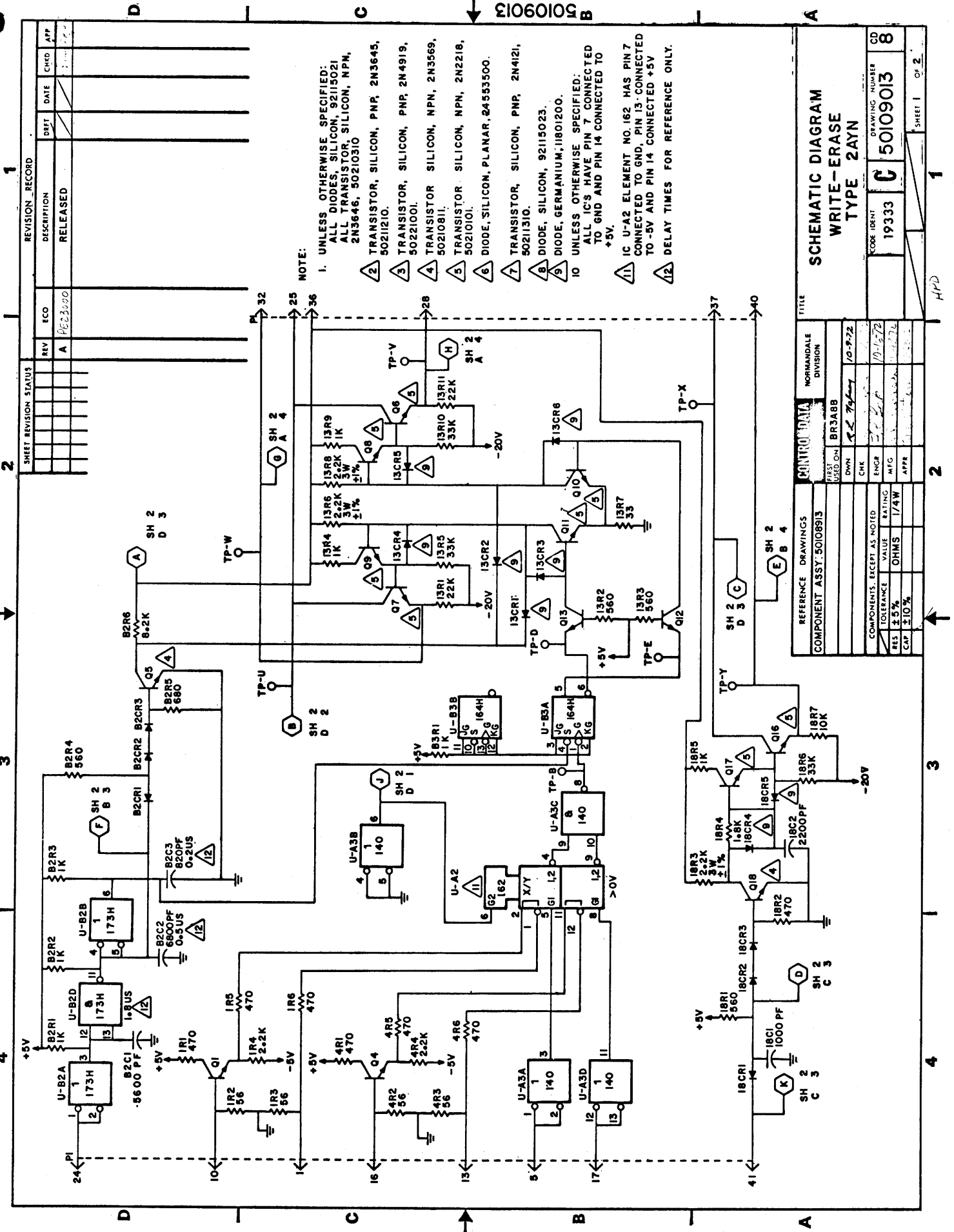

- NOTE:
1. UNLESS OTHERWISE SPECIFIED:
ALL DIODES, SILICON, 5Z115021
ALL TRANSISTORS, SILICON, NPN,
2N3646, 50210310
 2. TRANSISTOR, SILICON, PNP, 2N3645,
5021210.
 3. TRANSISTOR, SILICON, PNP, 2N4919,
50221001.
 4. TRANSISTOR SILICON, NPN, 2N3569,
50210811.
 5. TRANSISTOR SILICON, NPN, 2N2218,
50210101.
 6. DIODE, SILICON, PLANAR, 24583500.
 7. TRANSISTOR, SILICON, PNP, 2N4121,
50211310.
 8. DIODE, SILICON, 92115023.
 9. DIODE, GERMANIUM, 1B01200.
 10. UNLESS OTHERWISE SPECIFIED:
ALL IC'S HAVE PIN 7 CONNECTED
TO GND AND PIN 14 CONNECTED TO
+5V.
 11. IC U-A2 ELEMENT NO. 162 HAS PIN 7
CONNECTED TO GND, PIN 13 CONNECTED
TO -5V AND PIN 14 CONNECTED +5V
 12. DELAY TIMES FOR REFERENCE ONLY.

REVISION RECORD

REV	ECO	DESCRIPTION	DATE	CHKD	APP
A	PE23200	RELEASED			

SHEET REVISION STATUS

SCHMATIC DIAGRAM
WRITE-ERASE
TYPE 2AYN

REFERENCE DRAWINGS		CONTROL DATA		NORMANDALE DIVISION	
COMPONENT ASSY: 50108913	FIRST DESIGN: BR3A8B	CHK	10-9-72	CODE IDENT	19333
TOLERANCE	VALUE	RATING	MFG	DRAWING NUMBER	50109013
RES ±5%	OHMS	1/4W	APPR		
CAP ±10%					

1
2
3
4

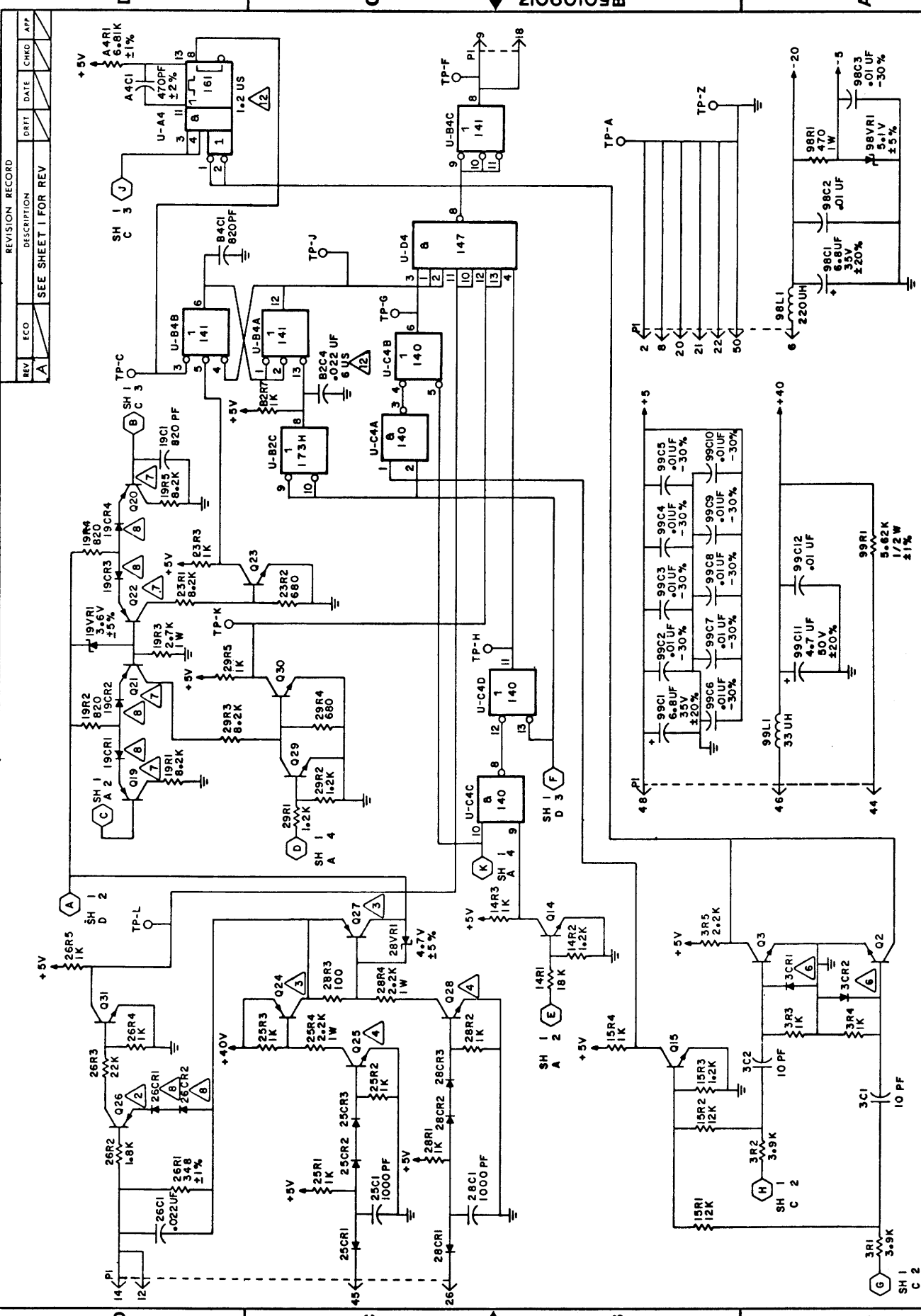

REVISION RECORD		DRFT	DATE	CHKD	APP
REV	ECO	DESCRIPTION			
A		SEE SHEET 1 FOR REV			

CD	DWG NO	SHEET 2
19333	50109013	8

SCHEMATIC DIAGRAM
WRITE-ERASE
TYPE 2AYN

CONTROL DATA CORPORATION
NORMANVILLE DIVISION

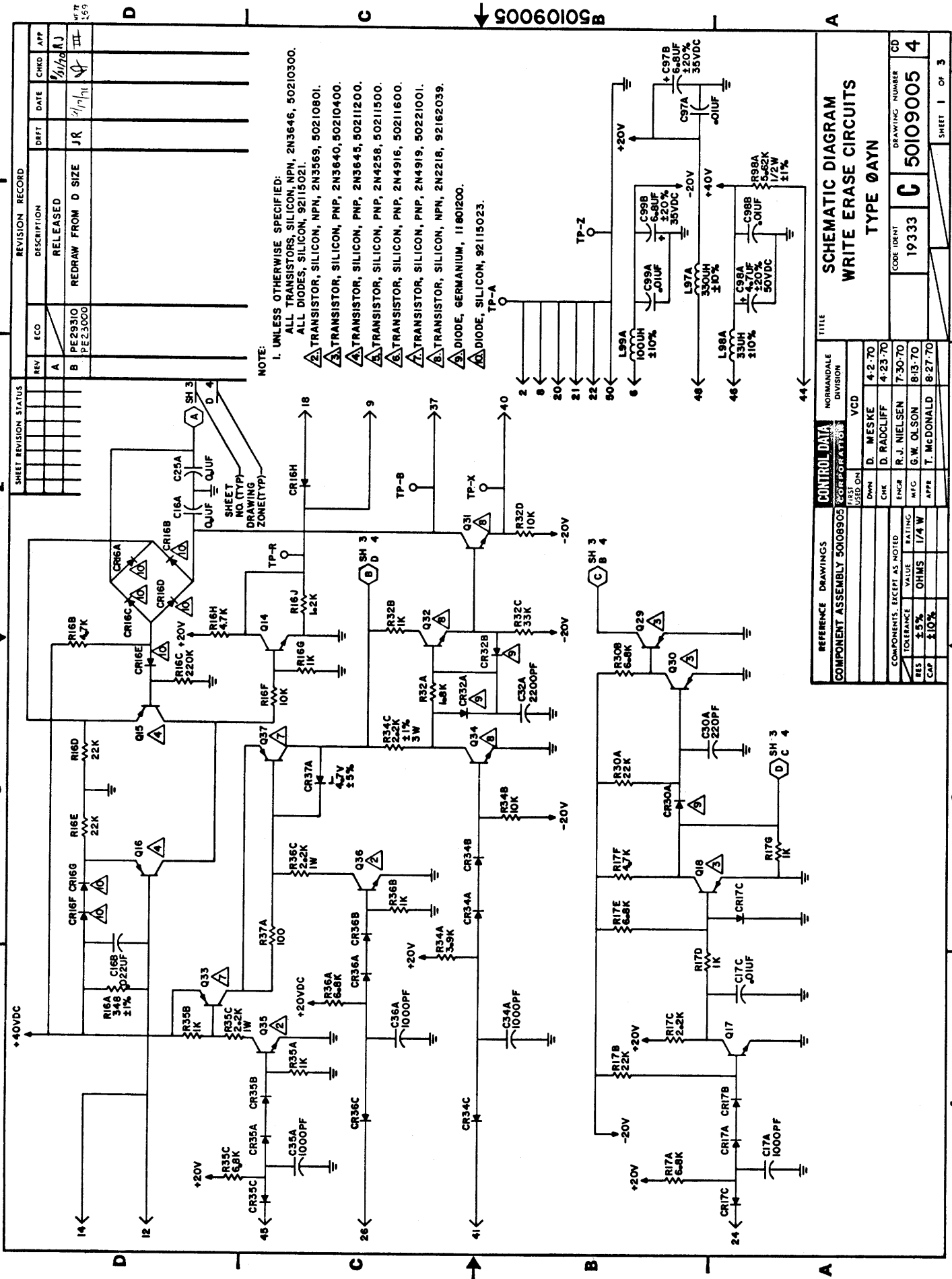

NOTE:
 1. UNLESS OTHERWISE SPECIFIED:
 ALL TRANSISTORS, SILICON, NPN, 2N3646, 50210300.
 ALL DIODES, SILICON, 92115021.
 Δ TRANSISTOR, SILICON, NPN, 2N3569, 50210801.
 Δ TRANSISTOR, SILICON, PNP, 2N3640, 50210400.
 Δ TRANSISTOR, SILICON, PNP, 2N3645, 50211200.
 Δ TRANSISTOR, SILICON, PNP, 2N4258, 50211500.
 Δ TRANSISTOR, SILICON, PNP, 2N4916, 50211600.
 Δ TRANSISTOR, SILICON, PNP, 2N4919, 50221001.
 Δ TRANSISTOR, SILICON, NPN, 2N2218, 92162039.
 Δ DIODE, GERMANIUM, 11801200.
 Δ DIODE, SILICON, 92115023.

SHEET REVISION STATUS		REVISION RECORD		
REV	ECO	DESCRIPTION	DATE	CHKD APP
A		RELEASED	7/1/71	JR
B	PE29310 PE23000	REDRAW FROM D SIZE		

REFERENCE DRAWINGS		CONTROL DATA		TITLE	
COMPONENT ASSEMBLY	5010905	REVISION	DATE	NORMAN DALE	DIVISION
		USED ON		VCD	
CHK	D. MESKE	ENGR	4-23-70		
ENGR	R. J. NIELSEN	MFG	7-30-70		
RES	±5%	VAL	813-70		
CP	±10%	RATING	8-27-70		
		APPR	T. McDONALD		
				CODE IDENT	19333
				DRAWING NUMBER	50109005
					4
SHEET 1 OF 3					

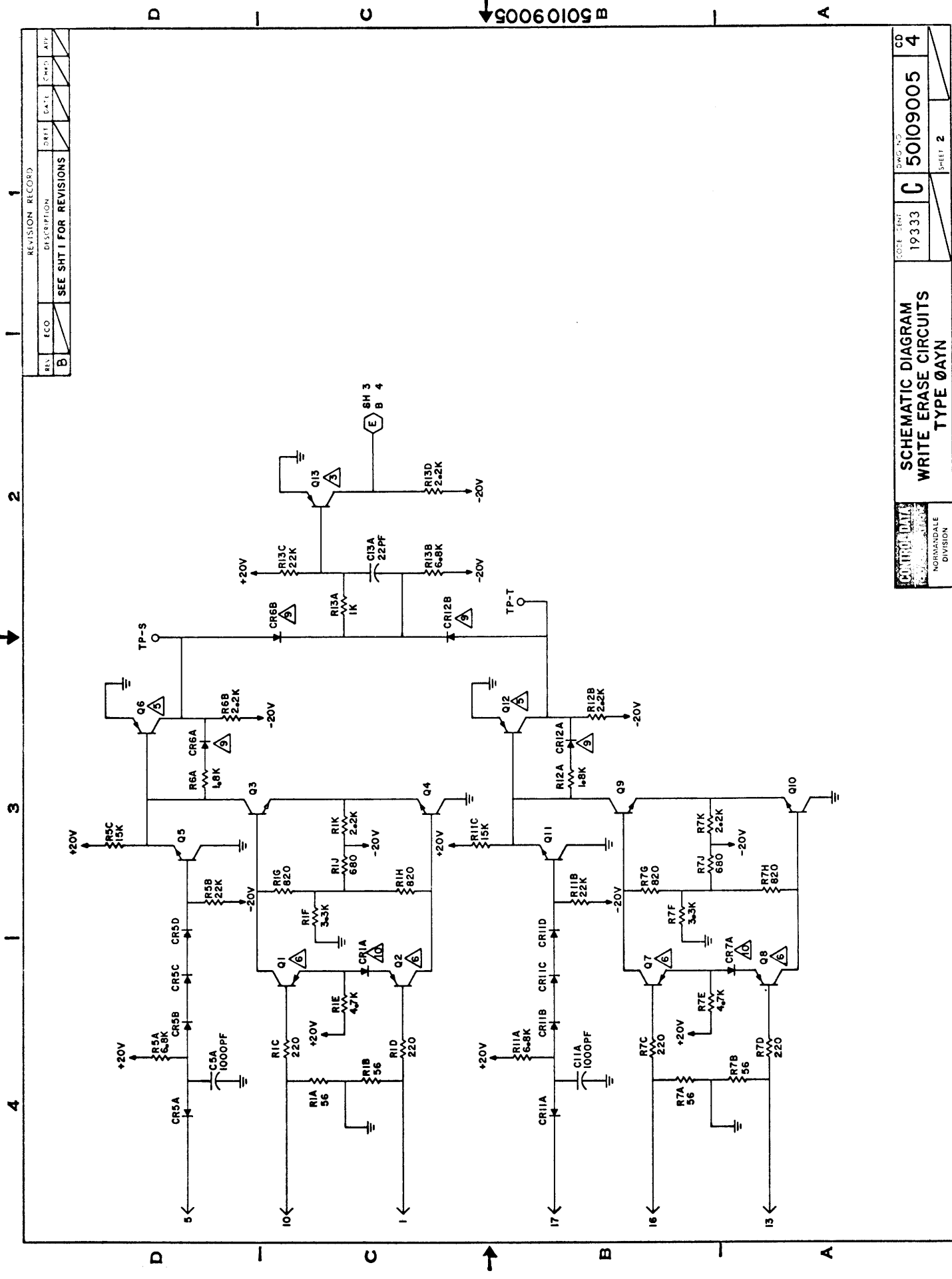

B 50109005

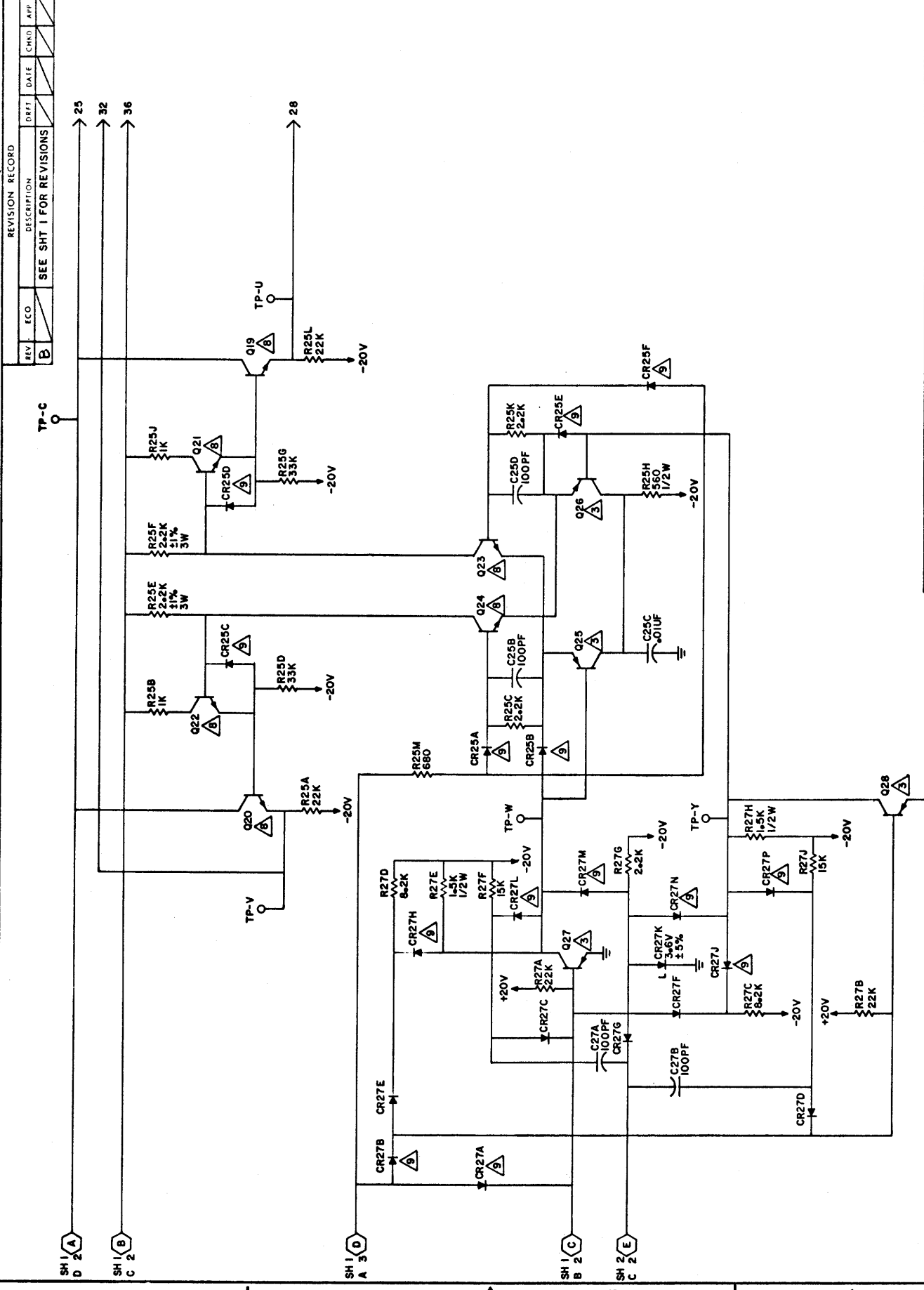

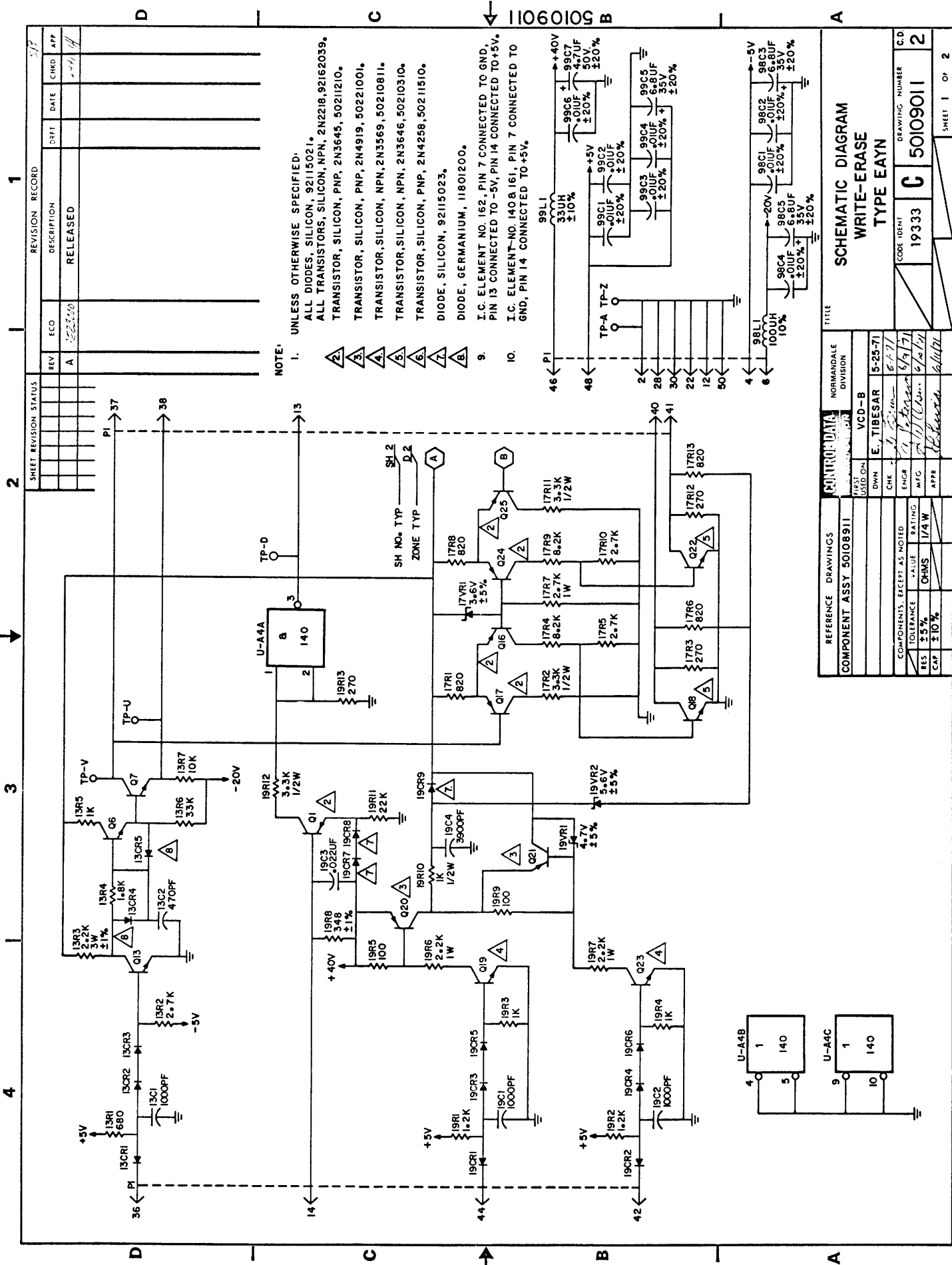

NOTE:

1. UNLESS OTHERWISE SPECIFIED:
 ALL DIODES, SILICON, 92115021.
 ALL TRANSISTORS, SILICON, NPN, 2N2219, 92162039,
 TRANSISTOR, SILICON, PNP, 2N3645, 50211210.
 TRANSISTOR, SILICON, PNP, 2N4919, 50221001.
 TRANSISTOR, SILICON, NPN, 2N3569, 50210811.
 TRANSISTOR, SILICON, NPN, 2N3646, 50210310.
 TRANSISTOR, SILICON, PNP, 2N4258, 50211510.
 DIODE, SILICON, 92115023.
 DIODE, GERMANIUM, 11801200.
 I.C. ELEMENT NO. 162, PIN 7 CONNECTED TO GND,
 PIN 15 CONNECTED TO -5V, PIN 14 CONNECTED TO +5V.
 I.C. ELEMENT NO. 140B 161, PIN 7 CONNECTED TO
 GND, PIN 14 CONNECTED TO +5V.

**SCHEMATIC DIAGRAM
 WRITE-ERASE
 TYPE EAYN**

REFERENCE DRAWINGS	CONTROL DATA	NORMANDALE DIVISION
COMPONENT ASSY 50108911	ISSN 5-25-71	VGD-B
DESIGNER	CHK	ENGR
DWN	E. TIBESAR	6-7-71
DATE	6-7-71	6-7-71
APPR	6/8/71	6/8/71
TOLERANCE, EXCEPT AS NOTED	RES ± 5%	CAP ± 10%
OHMS 1/4W		
DRAWING NUMBER	19333	C 50109011
CODE IDENT		
SHEET 1 OF 2		

50109011

REV	ECO	DATE	BY	CHKD	NO.
SEE SHEET 1					
REVISION RECORD			C.D.		
DESCRIPTION			CODE IDENT	DWG NO	2
			19333	C	50109011
			SHEET 2 OF 2		
CONTROL DATA			NORMANDEALE DIVISION		
SCHEMATIC DIAGRAM			WRITE-ERASE		
TYPE EAYN					

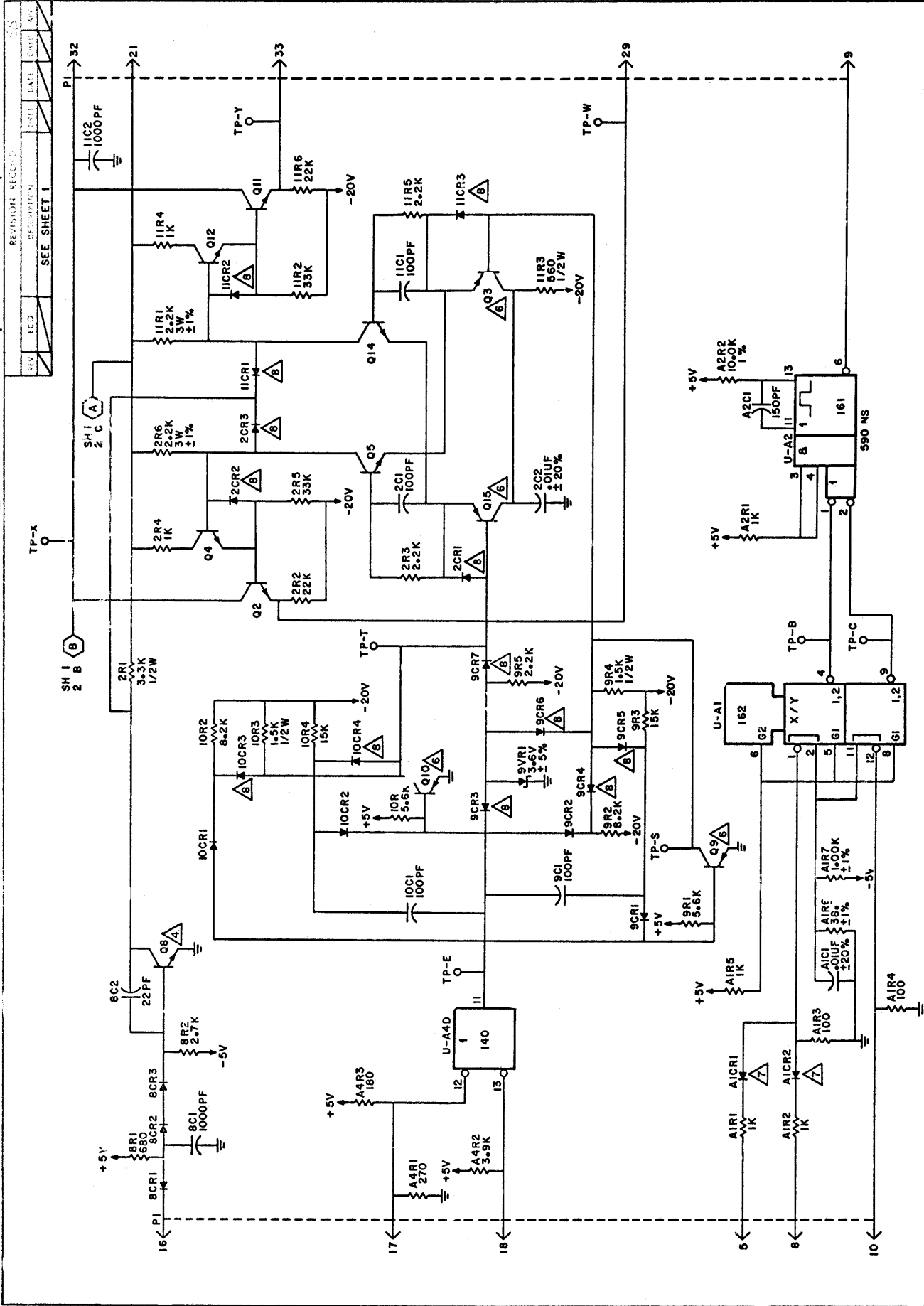

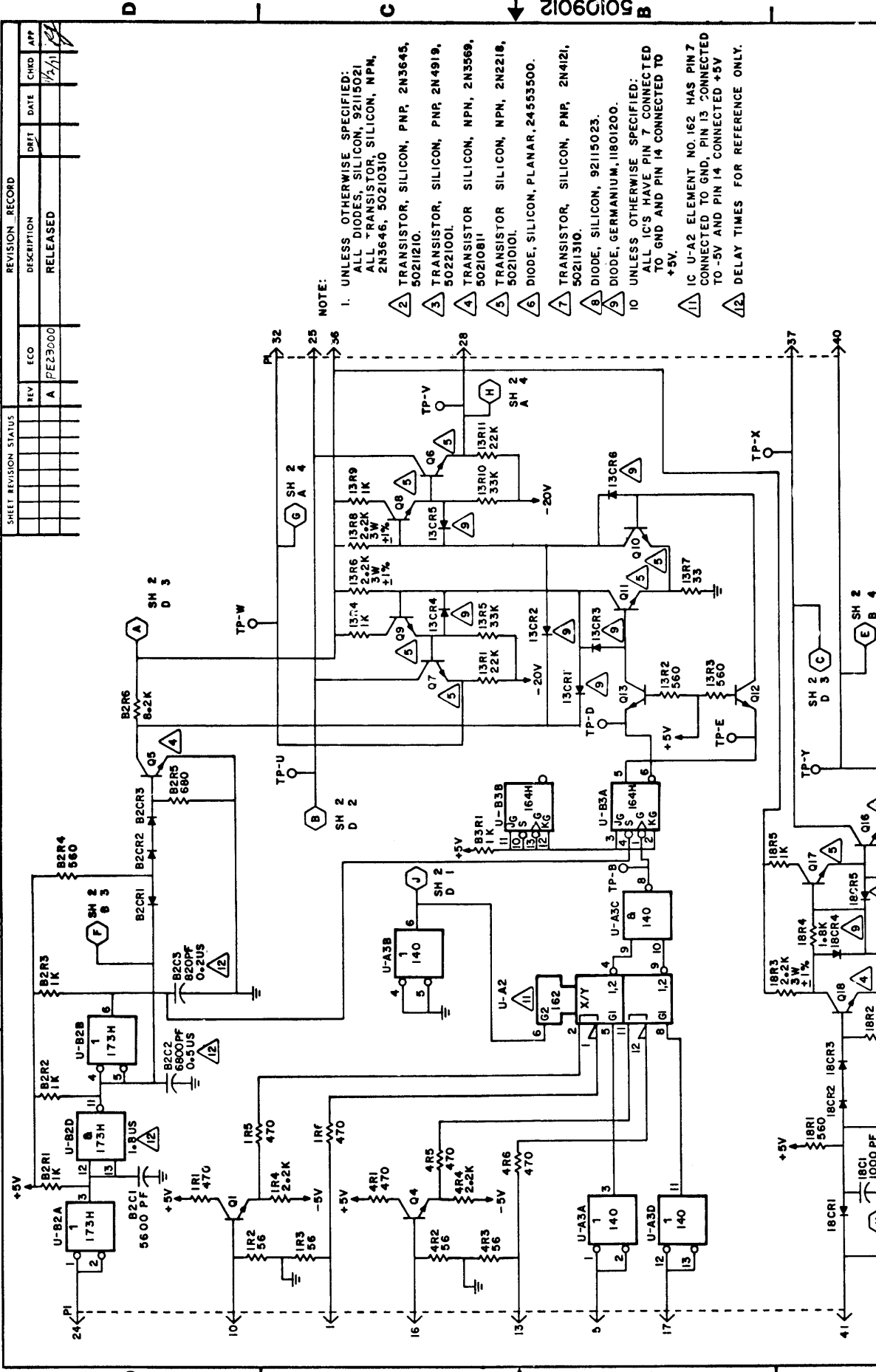

REVISION RECORD				DATE	CHKD	APP
REV	ECO	DESCRIPTION	RELEASED			
A	PEZ3000			7/11		

SHEET REVISION STATUS		CONTROL DATA		NORMAN DALE		DIVISION		BRSAIA	
DOWN	Q MARTIN	7-9-71		ENGR	7-27-71			APPR	7-28-71
CHEK	J. J. O'NEILL	7-23-71		MIG	7-26-71				

REFERENCE DRAWINGS		COMPONENTS EXCEPT AS NOTED		TOLERANCE VALUE		RATING		OHMS		1/4W	
RES	±5%	CAP	±10%								

TITLE	SCHEMATIC DIAGRAM	WRITE-ERASE	TYPE	FAYN
COMPONENT ASSY: 5010912				

FORM NO.	DATE	REV	ISSUE
19333	19333	C	5010912

SHEET 1 OF 2	
--------------	--

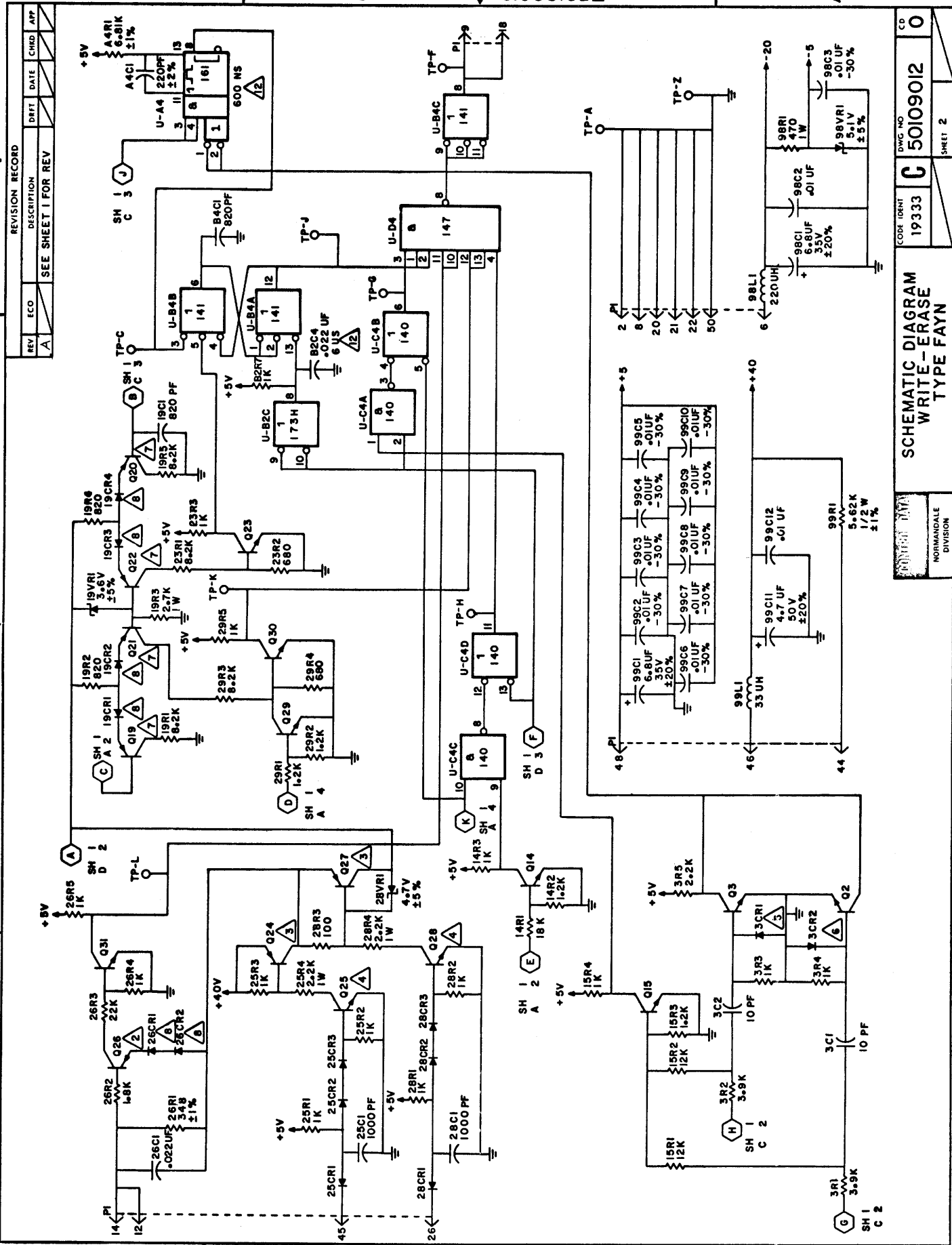

REV	ECO	DESCRIPTION	DATE	CHD	APP
A		SEE SHEET 1 FOR REV			

REVISION RECORD

SCHEMATIC DIAGRAM
WRITE-ERASE
TYPE FAWN

CODE IDENT 19333

DWG. NO G 50109012

NORMANVILLE DIVISION

SHEET 2

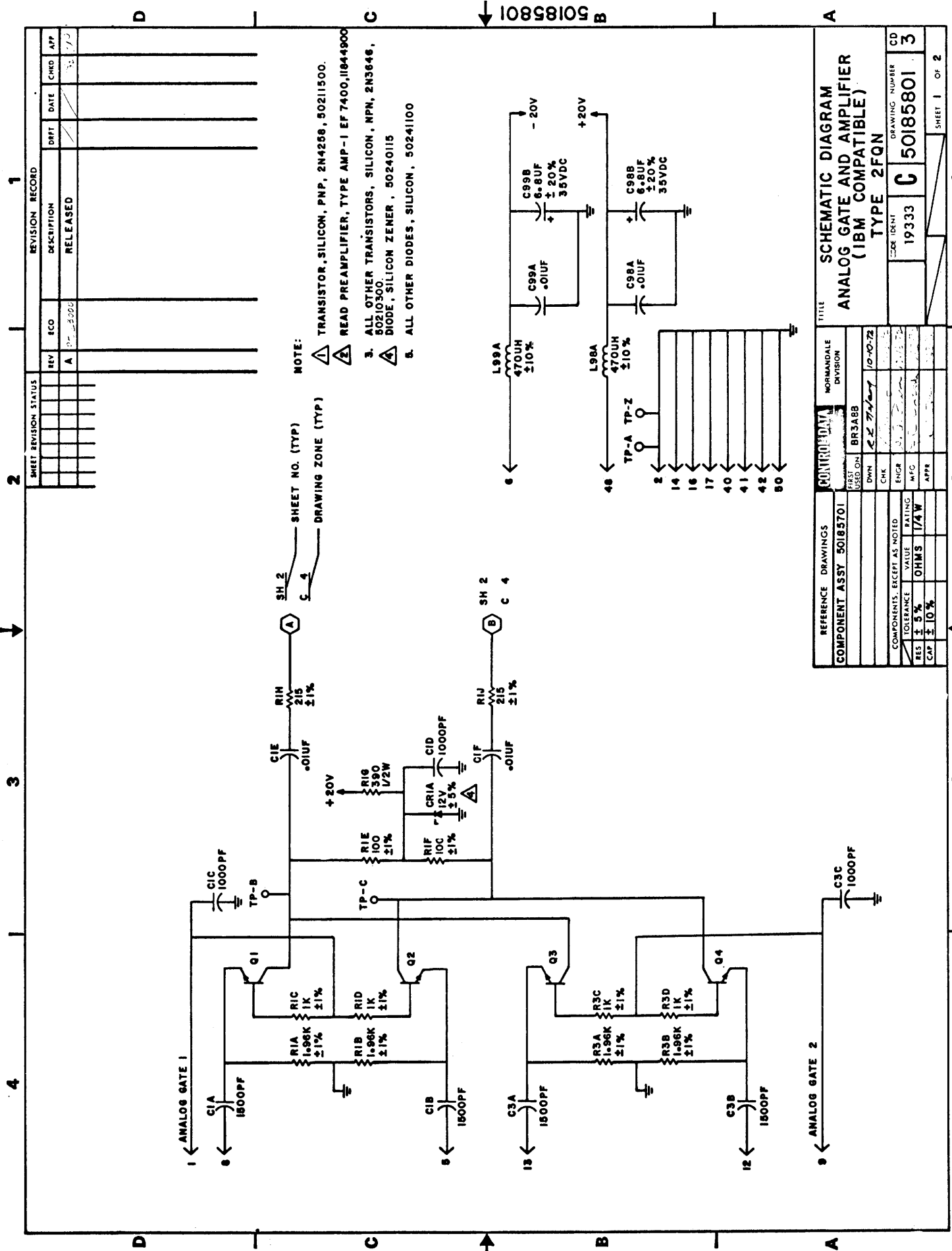

- NOTE:
- 1. TRANSISTOR, SILICON, PNP, 2N4256, 50211500.
 - 2. READ PREAMPLIFIER, TYPE AMP-1 EF 7400, I1844900.
 - 3. ALL OTHER TRANSISTORS, SILICON, NPN, 2N3646, 50210300.
 - 4. DIODE, SILICON ZENER, 50240115.
 - 5. ALL OTHER DIODES, SILICON, 50241100.

REVISION RECORD		SHEET REVISION STATUS		REV		ECO		DESCRIPTION		DRFT		DATE		CHKD		APP	
				A		5020		RELEASED									
TITLE		NORMANDEALE DIVISION		CONTROL DATA		BR348B		FIRST USED ON		10-10-72		DWN		CHK		ENGR	
REFERENCE DRAWINGS		COMPONENT ASSY 50185701		TOLERANCE		VALUE		RATING		MFC		RES		OHMS		I/W	
SCHEMATIC DIAGRAM		ANALOG GATE AND AMPLIFIER		COMPONENTS EXCEPT AS NOTED		1/4 W		1/4 W		1/4 W		CAP		10%		10%	
DRAWING NUMBER		50185801		CODE IDENT		19333		DRAWING NUMBER		CD		3		SHEET 1		OF 2	

50185801 B

1

2

3

4

D

C

B

A

D

C

B

A

REVISION RECORD			
REV	ECO	DESCRIPTION	DATE
A		SEE SHI FOR REVISIONS	

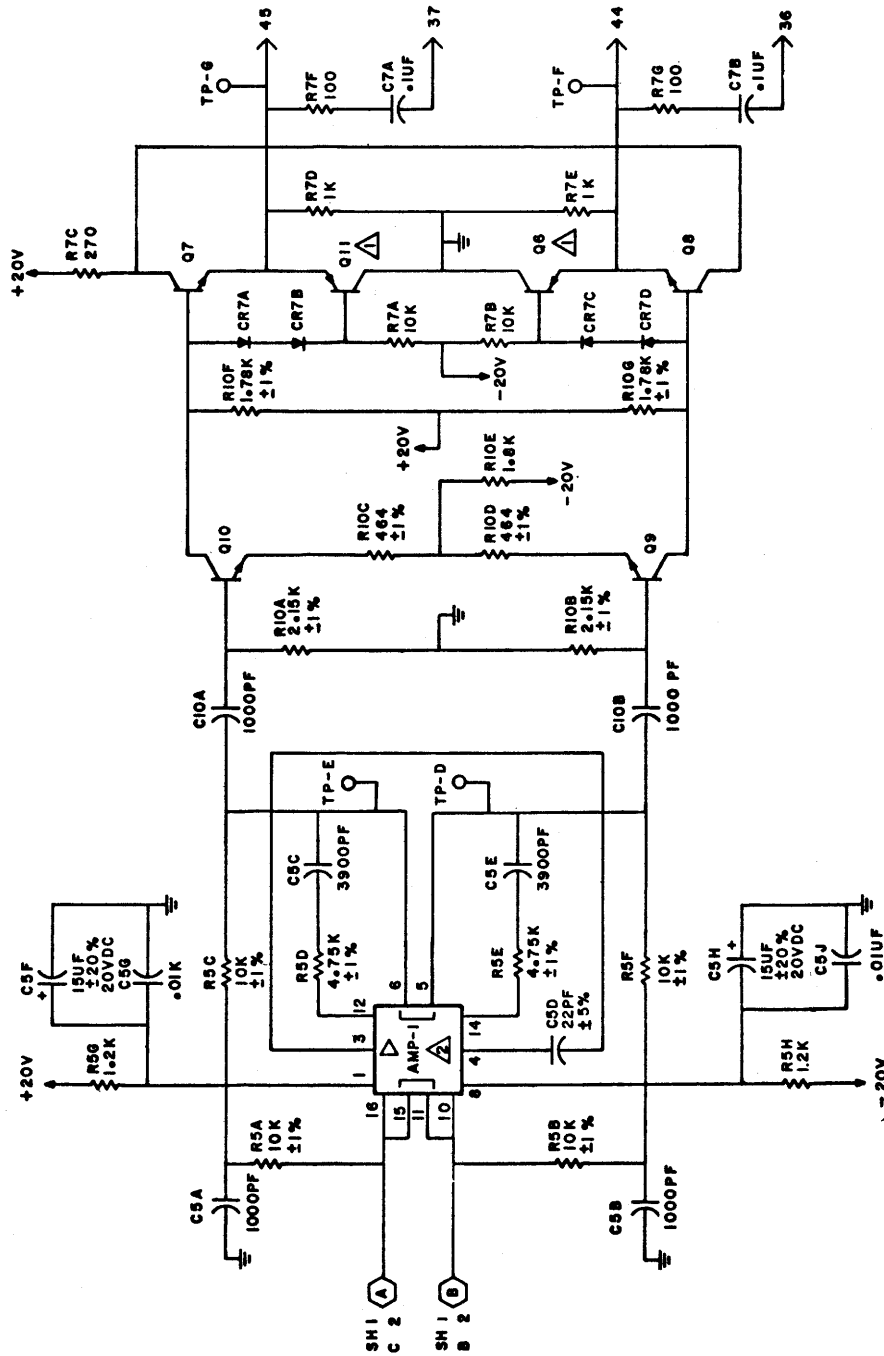

CONTROL DATA	SCHEMATIC DIAGRAM	DWG. NO.	CD
COMPONENTS	ANALOG GATE AND AMPLIFIER	C	50185801
NORMANDALE DIVISION	(IBM COMPATIBLE)	19333	3
	TYPE 2FQN	2	1

SHEET REVISION STATUS		REVISION RECORD			
REV	ECO	DESCRIPTION	DATE	CHKD	APP
A		RELEASED	7/14/69		
B	PE29310	DOC SIZE & SYM CHANGE	7-4-71		
	PE23000				

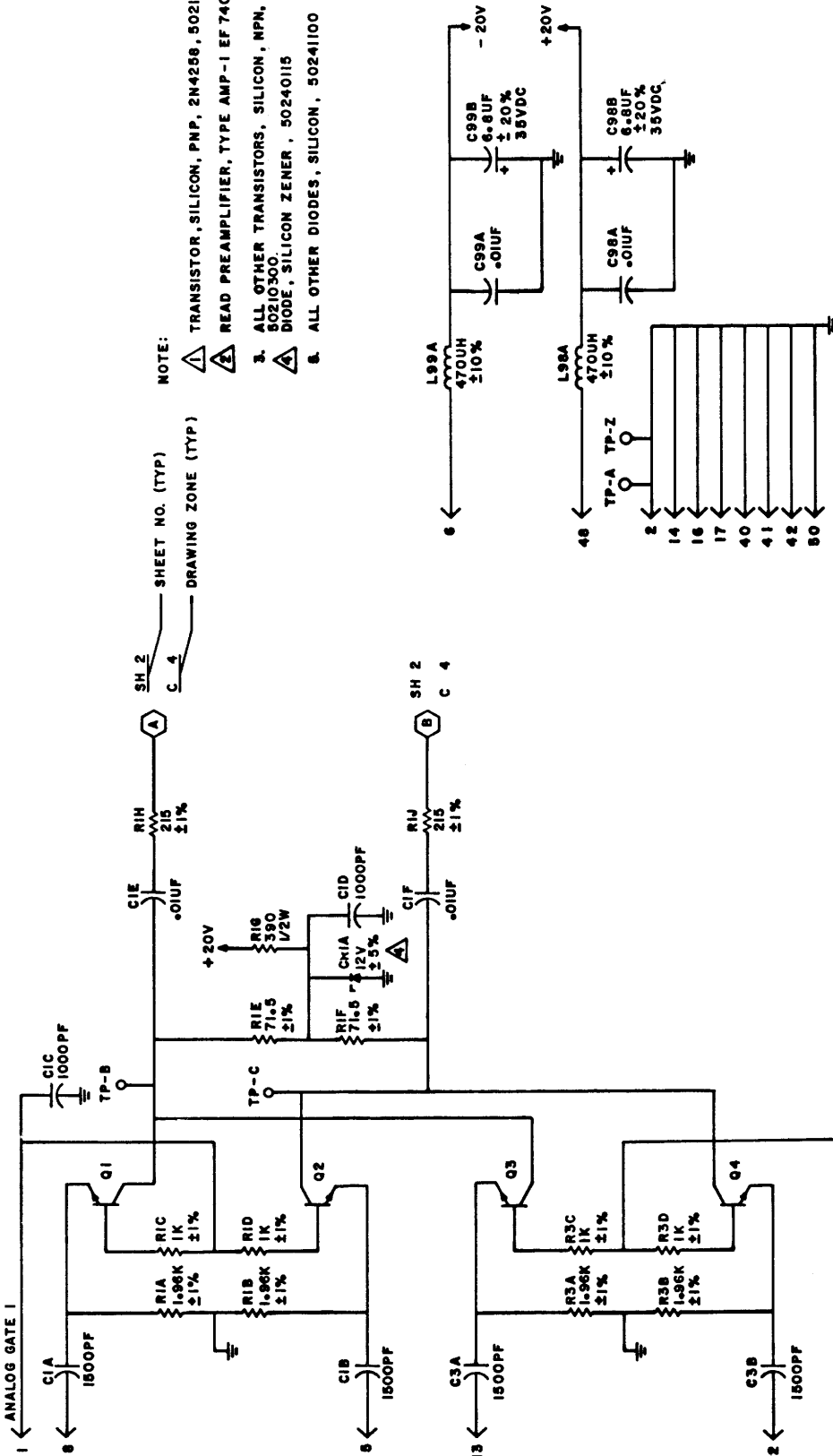

NOTE:
 1. TRANSISTOR, SILICON, PNP, 2N4258, 50211500.
 2. READ PREAMPLIFIER, TYPE AMP-1 EF 7400, 11844900.
 3. ALL OTHER TRANSISTORS, SILICON, NPN, 2N3646, 50210300.
 4. DIODE, SILICON ZENER, 50240115
 5. ALL OTHER DIODES, SILICON, 50241100

REFERENCE DRAWINGS		CONTROL DATA		NORMANDALE DIVISION	
COMPONENT ASST	50185700	USED ON	DUAL CHANNEL RESOB	CHK	F MANNING
DWN		ENGR	P. J. ...	APPR	H. S. ...
RES	± 5%	TOLERANCE	VALUE		
CAP	± 10%	RATING	1/4 W		
TITLE		SCHEMATIC DIAGRAM			
ANALOG GATE AND AMPLIFIER		(IBM COMPATIBLE)			
TYPE		9FQN			
DRAWING NUMBER		C 50185800			
CODE IDENT		19333			
SHEET 1 OF 2					

50185800 B

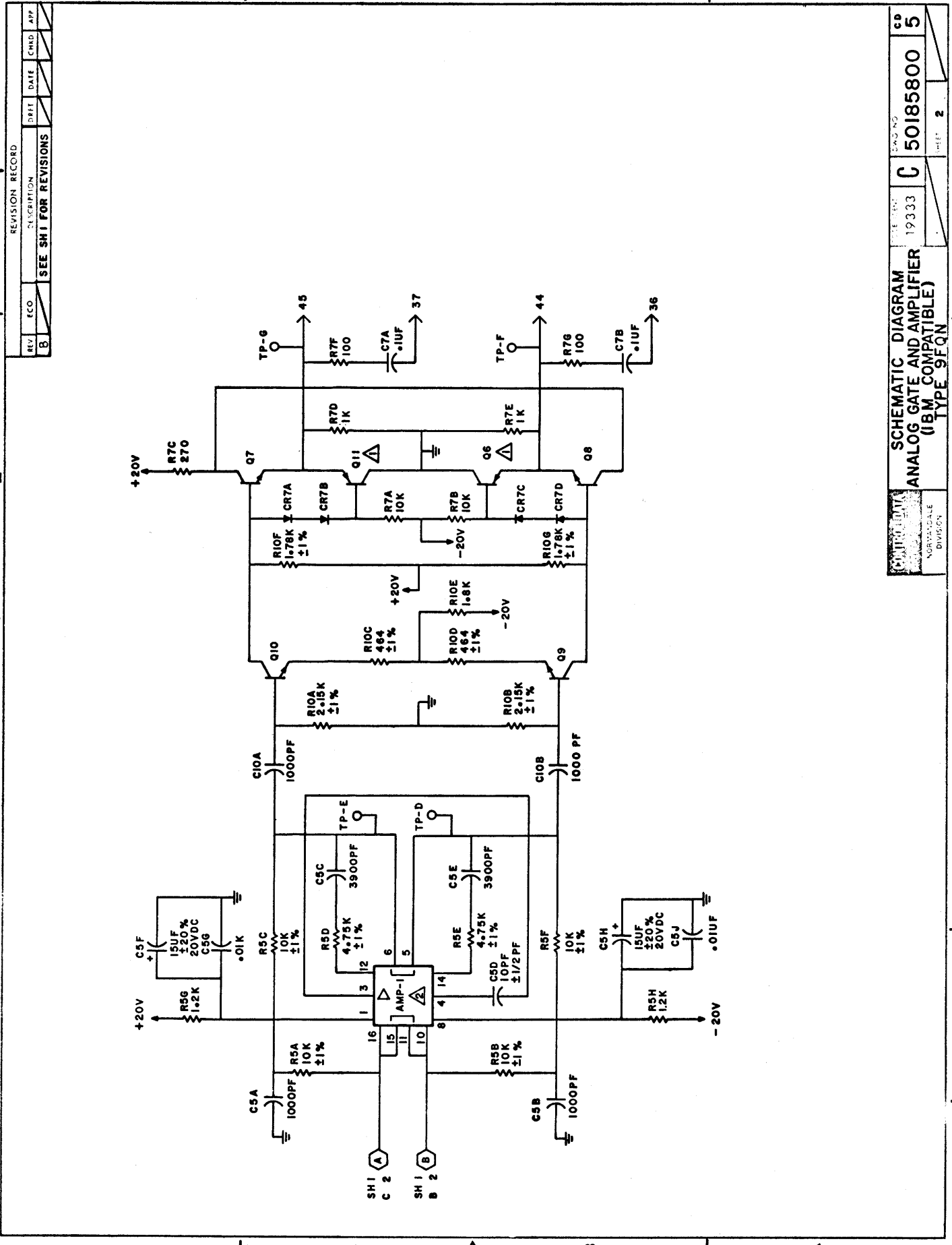

REV	ECO	DESCRIPTION	DATE	CHKD	APP
B		SEE SHI FOR REVISIONS			

CD	5
50185800	
19333	
C	
50185800	
2	

SCHEMATIC DIAGRAM
ANALOG GATE AND AMPLIFIER
(IBM COMPATIBLE)
TYPE 9FQN

IBM CORPORATION
NORWICH DIVISION

REV	ECO	DESCRIPTION	DRFT	DATE	CHRD	APP
A	PE29310 PE23000	RELEASED	7.5	6/19/71		
B		REDRAWN FROM D SIZE				

NOTE:
1. UNLESS OTHERWISE SPECIFIED:
ALL TRANSISTORS, SILICON, NPN, 2N3646,
50210310.

- TRANSISTOR, SILICON, PNP 2N4258, 50215110.
- ALL INTEGRATED CIRCUIT PACKAGES HAVE
PIN 7 CONNECTED TO GRD AND PIN 14
CONNECTED TO +5V

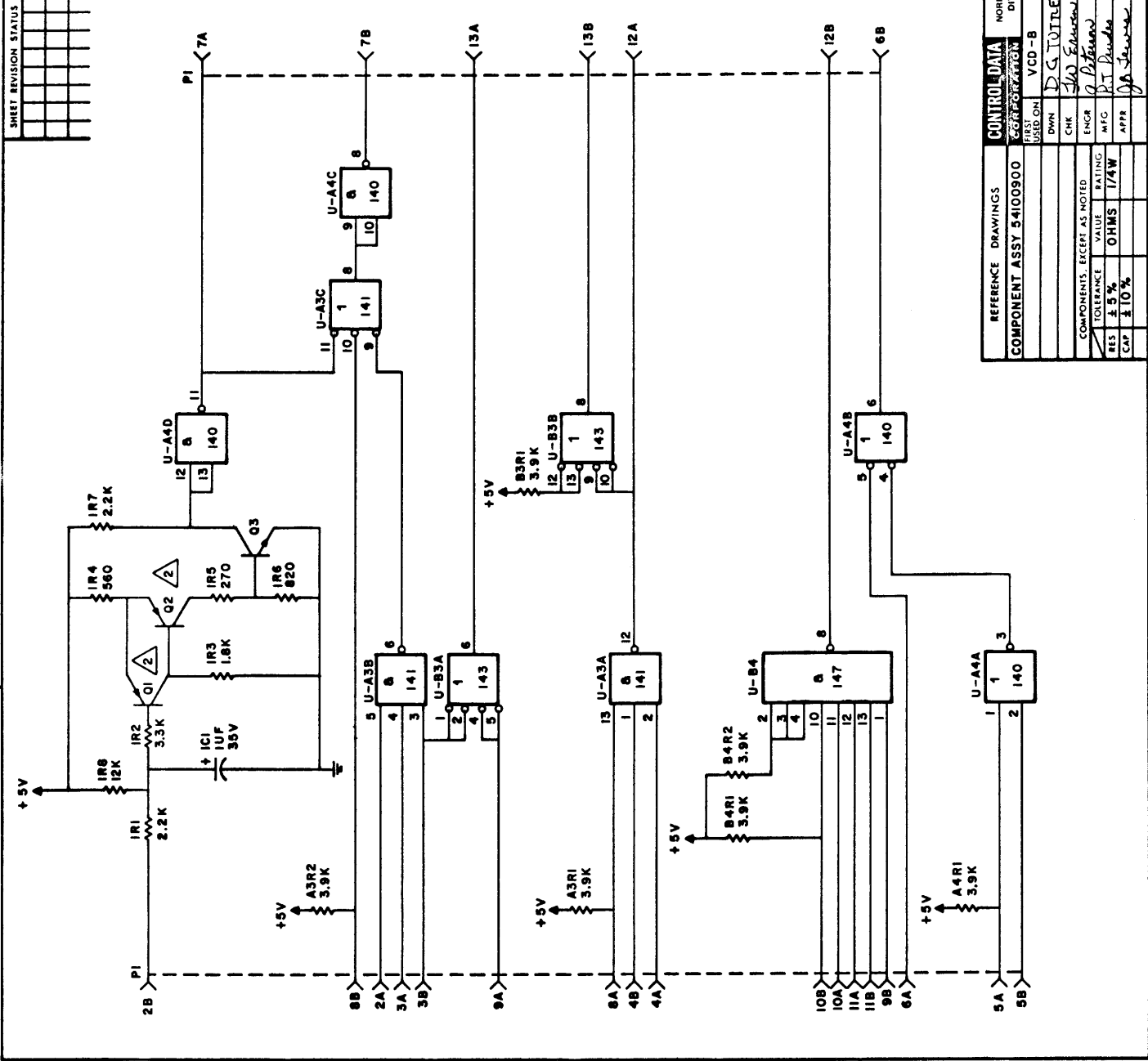

REFERENCE DRAWINGS	CONTROL DATA CORPORATION	NORMANDALE DIVISION
COMPONENT ASSY 54100900	VCD-B	
FIRST USED ON	DWN	D. G. TITILE 12-5-70
CHK	ENGR	J. J. DeWitt 1-5-71
COMPONENTS, EXCEPT AS NOTED	MFC	P. J. DeWitt 1-27-71
VALUE	RATING	APPR
TOLERANCE	OHMS	1/4W
RES ± 5%	CAP ± 10%	

TITLE	SCHEMATIC DIAGRAM	SELECT/RESET	TYPE ØBCV
CODE IDENT	19333	C	54101000
DRAWING NUMBER	54101000	5	

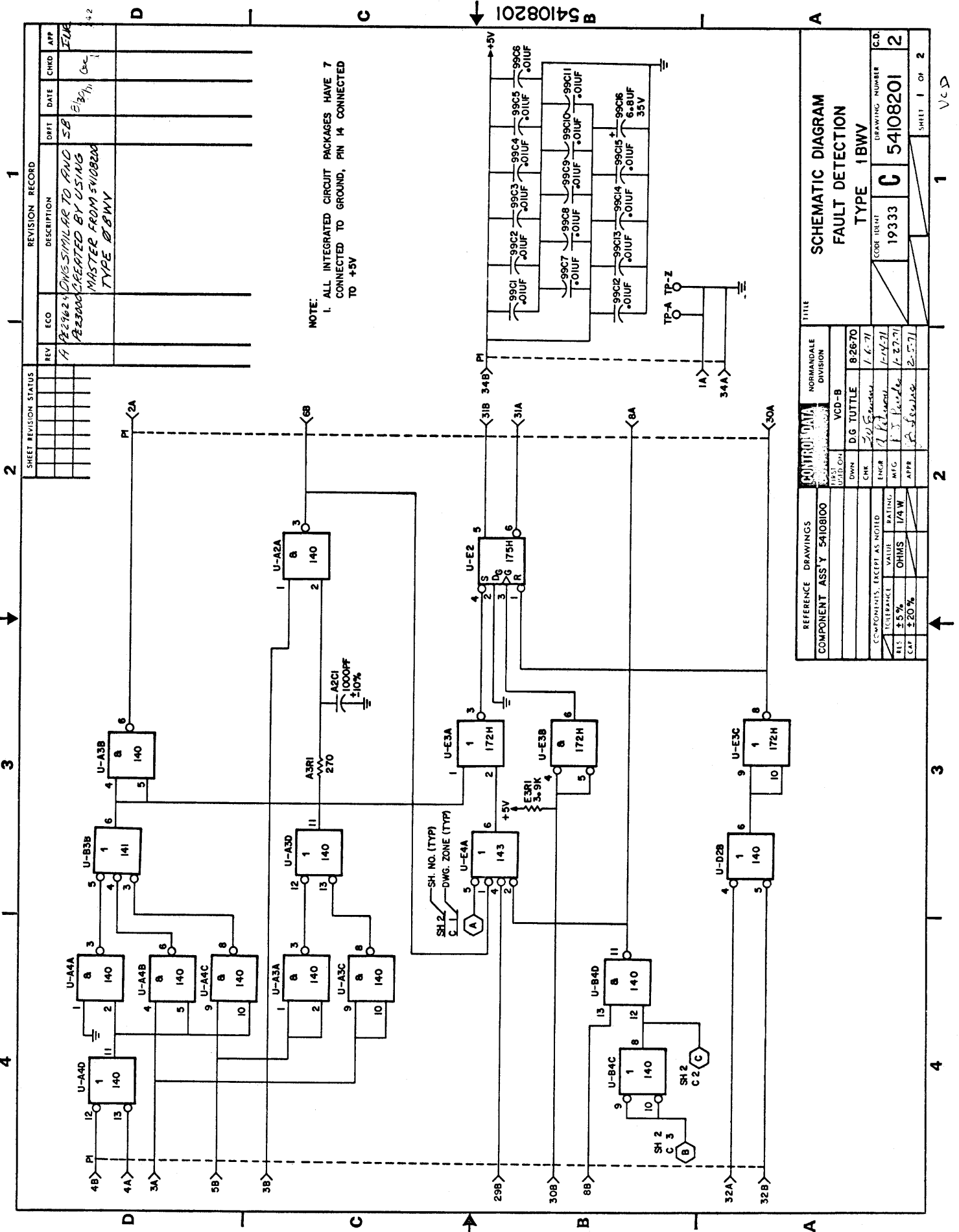

SHEET REVISION STATUS		REVISION RECORD			
REV	ECO	DESCRIPTION	DATE	CHD	APP
1					
2					
3					
4					
5					
6					
7					
8					
9					
10					
11					
12					
13					
14					
15					
16					
17					
18					
19					
20					

REFERENCE DRAWINGS		CONTROL DATA		NORMANDALE DIVISION	
COMPONENT	ASSY	UNIT	DESCRIPTION	DATE	BY
ASSY	54108201		VCD-B	8-26-70	
		DWN	D.G. TUTTLE	1-6-71	
		CHK		1-27-71	
		ENG		2-5-71	
		MTG			
		APPR			

SCHEMATIC DIAGRAM	
FAULT DETECTION	
TYPE 1BWV	
CODE IDENT	19333
DRAWING NUMBER	54108201
C.D.	2
SHEET	1 OF 2

TITLE	
SCHEMATIC DIAGRAM	
FAULT DETECTION	
TYPE 1BWV	
CODE IDENT	19333
DRAWING NUMBER	54108201
C.D.	2
SHEET	1 OF 2

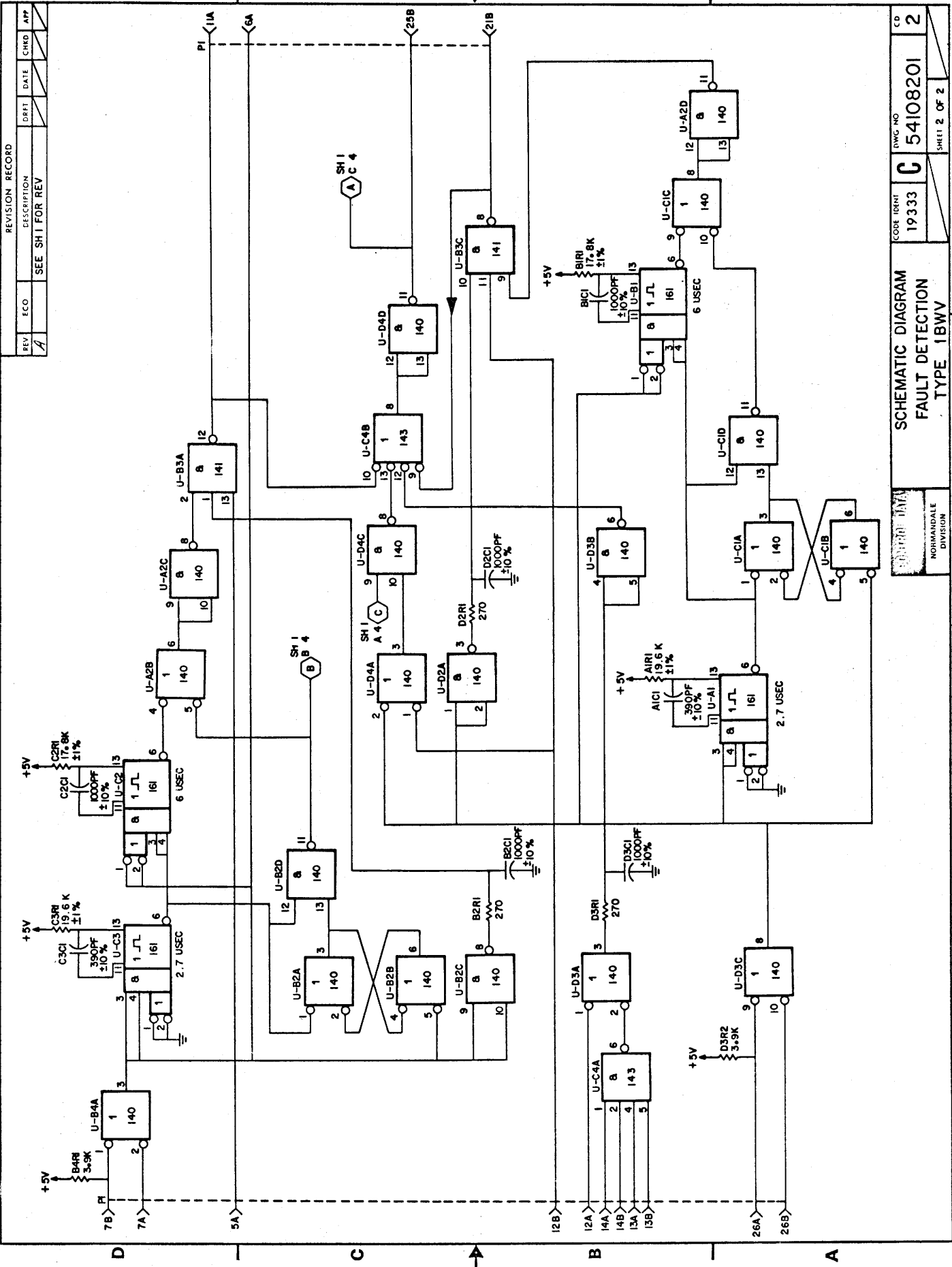

1
2
3
4

1
2
3
4

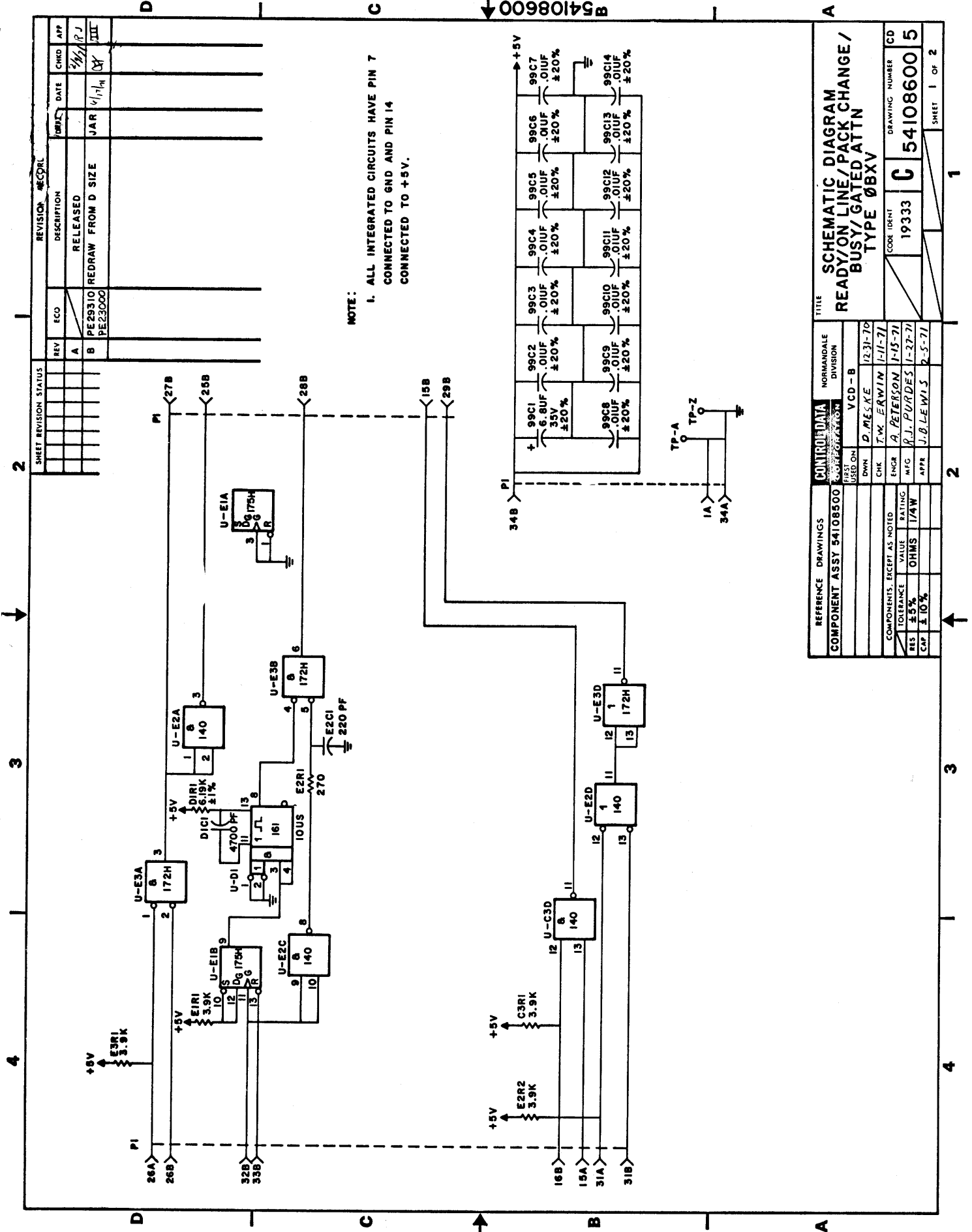

REFERENCE DRAWINGS		CONTROL DATA		NORMANDEALE DIVISION	
COMPONENT ASSY 54108500		VCD - B		D. MESSKE 12-31-70	
FIRST USED ON		CHK		T.W. ERWIN 1-11-71	
ENGR		MFG		R.J. PURDES 1-15-71	
APPR		APPR		J.B. LEWIS 2-5-71	
COMPONENTS EXCEPT AS NOTED		TOLERANCE VALUE		RATING	
RES ± 5%		OHMS		1/W	
CAP ± 10%					
TITLE		SCHEMATIC DIAGRAM		DRAWING NUMBER	
READY/ON LINE/PACK CHANGE /		BUSY/GATED ATTN		C 54108600 5	
TYPE ØBXV		CODE IDENT		19333	
SHEET 1 OF 2					

REVISION RECORD			
REV	ECO	DESCRIPTION	DATE
B		SEE SHEET 1 FOR REV	

REV	ECO	DESCRIPTION	DATE	CHKD	APP
B		SEE SHEET 1 FOR REV			

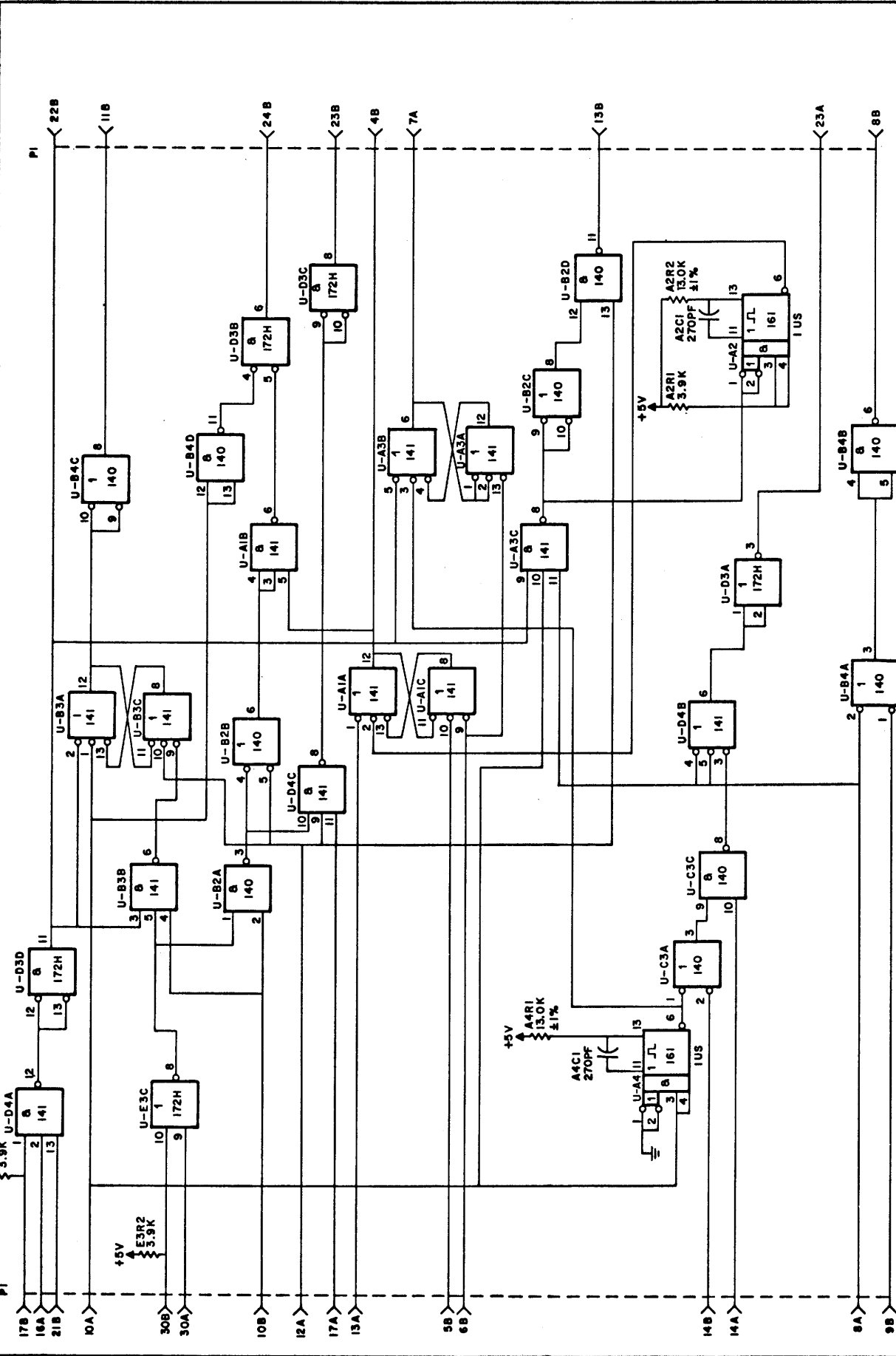

REV	ECO	DESCRIPTION	DATE	CHKD	APP
B		SEE SHEET 1 FOR REV			

SCHEMATIC DIAGRAM
 READY/ON LINE/PACK CHANGE
 /BUSY/GATED ATTN
 TYPE ØBXV

DWG. NO. 54108600
 SHEET 2

54108600

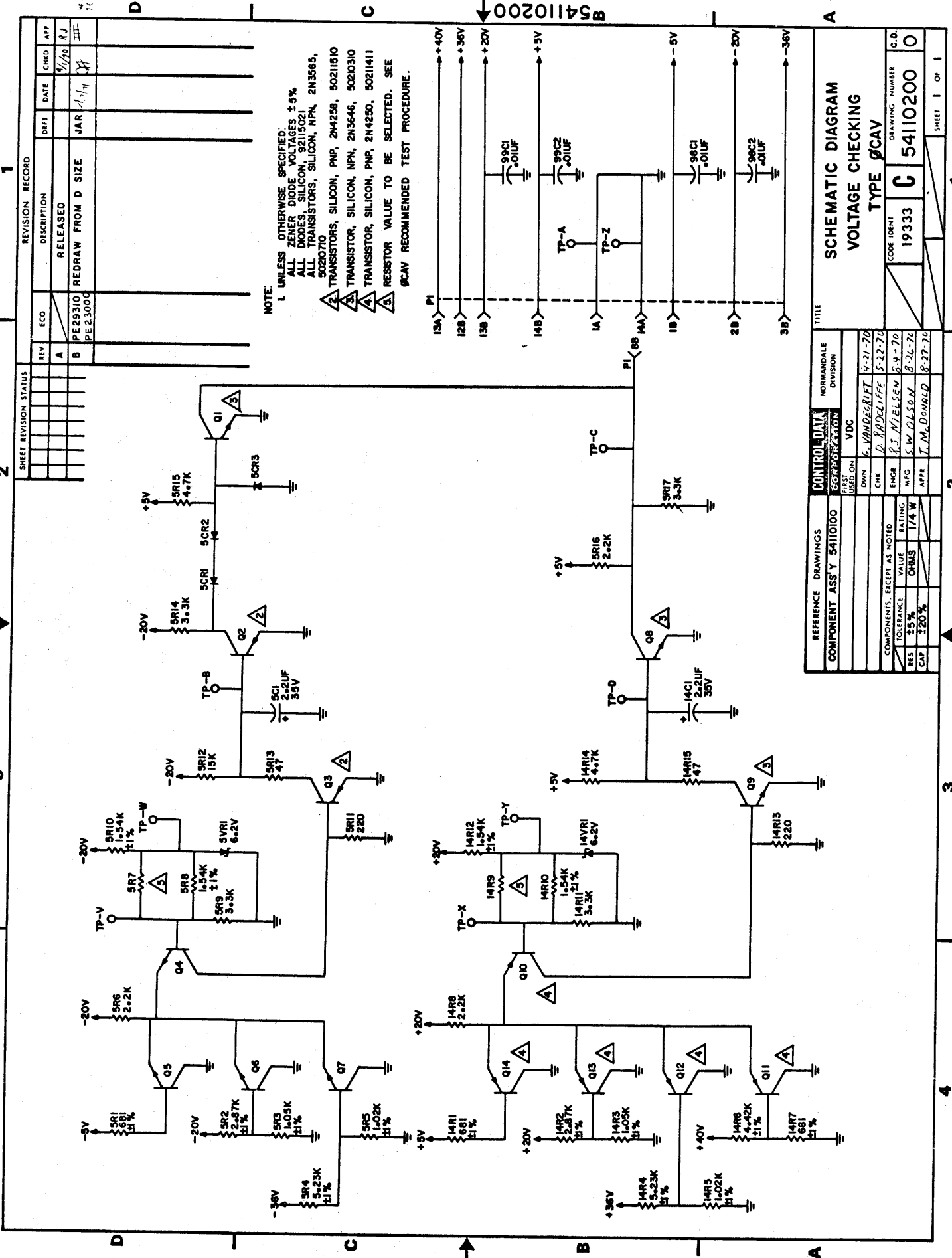

NOTE:
 1 UNLESS OTHERWISE SPECIFIED:
 ALL ZENER DIODE VOLTAGES ±5%
 ALL DIODES, SILICON, 92115021
 ALL TRANSISTORS, SILICON, MPM, 2N3565,
 5020710
 2 TRANSISTORS, SILICON, PNP, 2N4256, 90211510
 3 TRANSISTOR, SILICON, NPN, 2N3646, 9020310
 4 TRANSISTOR, SILICON, PNP, 2N4250, 90211411
 5 RESISTOR VALUE TO BE SELECTED. SEE
 9CAV RECOMMENDED TEST PROCEDURE.

SHEET REVISION STATUS		REVISION RECORD	
REV	ECO	DESCRIPTION	CHKD
A		RELEASED	RJ
B		REDRAW FROM D SIZE	JAR
PE29310			
PE23000			

REFERENCE DRAWINGS		CONTROL DATA CORPORATION	
COMPONENT ASSY	54110100	FIRST USED ON	VDC
DWN	C. VANDERKAM	ENGR	D. RADDLE
CHK	D. RADDLE	APP	T. M. DONALD
ENGR	R. J. MCELSEEN	DATE	8-26-70
MFG	S. W. OLSON	DATE	8-27-70
APP	T. M. DONALD	DATE	8-27-70

TITLE		NORMDALE DIVISION	
SCHEMATIC DIAGRAM		TYPE 9CAV	
VOLTAGE CHECKING		DRAWING NUMBER	
19333		54110200	
CODE IDENT		C.D.	
1		1	

1

2

3

4

1

2

3

4

B54110200

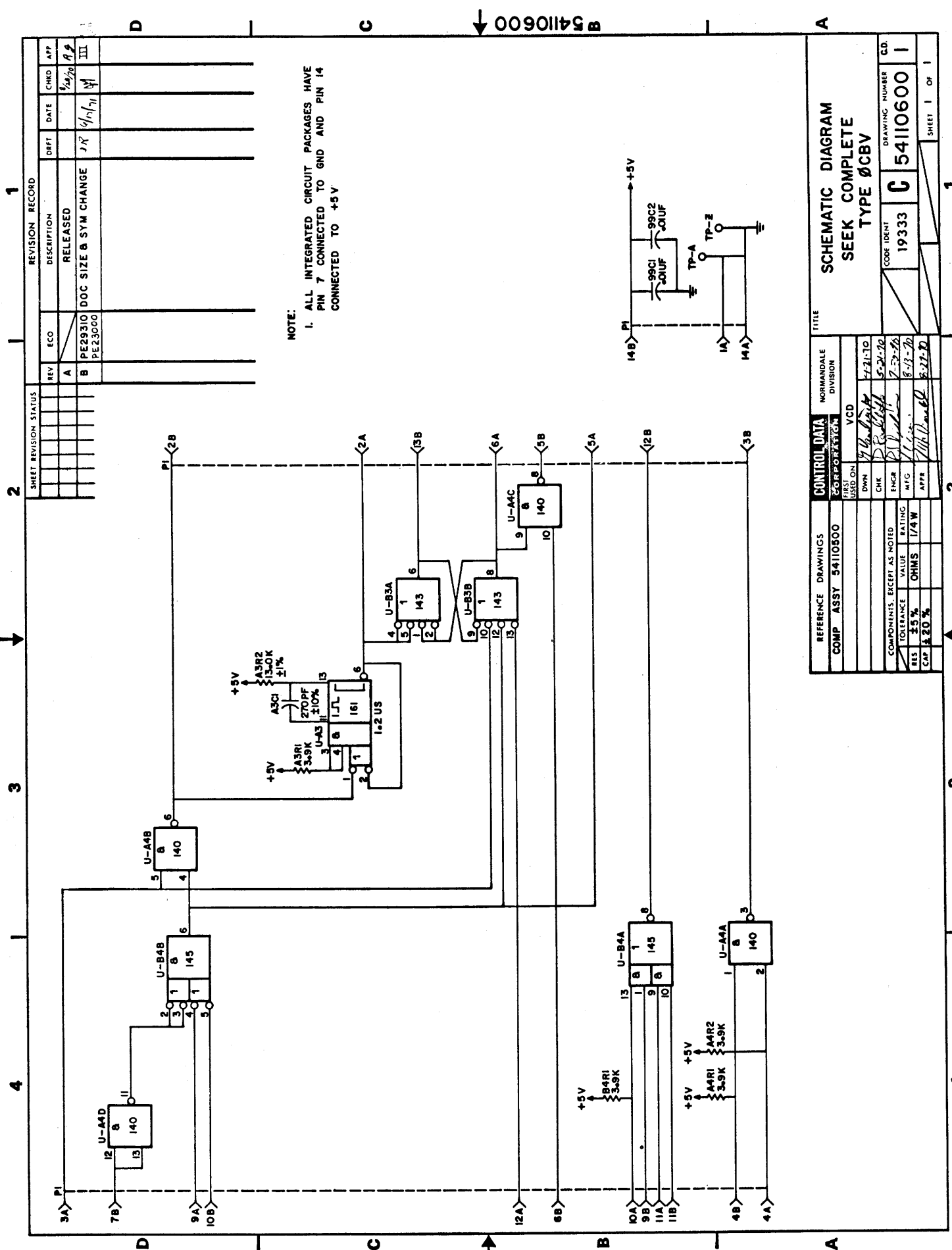

NOTE:
 1. ALL INTEGRATED CIRCUIT PACKAGES HAVE
 PIN 7 CONNECTED TO GND AND PIN 14
 CONNECTED TO +5V

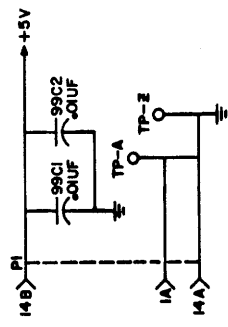

SHEET REVISION STATUS		REVISION RECORD	
REV	ECO	DESCRIPTION	DATE
A		RELEASED	9/20/70
B	PE29310 PE23000	DOC SIZE & SYM CHANGE	4/17/71

REV	ECO	DESCRIPTION	DATE	CHKD	APP
A		RELEASED	9/20/70		AS
B	PE29310 PE23000	DOC SIZE & SYM CHANGE	4/17/71		III

REFERENCE DRAWINGS		CONTROL DATA		NORMANDALE DIVISION	
COMP	ASSY	NO.	REV.	USED ON	VCD
	54110500				
COMPONENTS EXCEPT AS NOTED		CHK	DWN	1-21-70	
TOLERANCE	VALUE	ENG		5-21-70	
RES	±5%	MFG		7-29-70	
CAP	±20%	APP		8-19-70	
				8-27-70	

SCHEMATIC DIAGRAM		SEEK COMPLETE		TYPE ØCBV	
TITLE	COORD IDENT	DRAWING NUMBER	C.D.	SHEET 1 OF 1	
SEEK COMPLETE	19333	54110600	I		

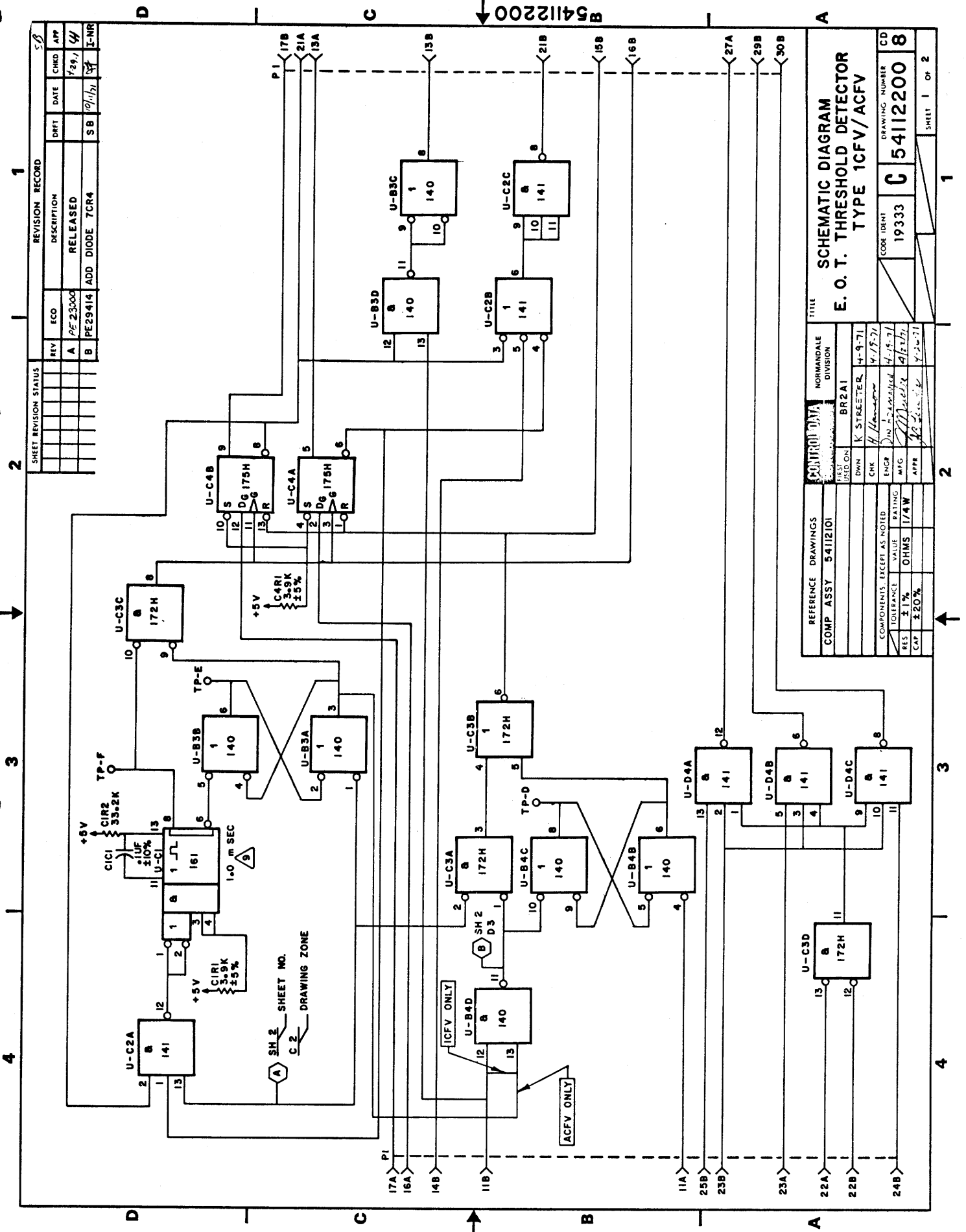

REFERENCE DRAWINGS		CONTROL DATA		NORMANDALE DIVISION	
COMP ASSY	54112101	TEST USED ON	BR2A1	CHK	K STEETER
		DWN		ENGR	H [Signature]
		APPR		MTG	DIN [Signature]
COMPONENTS, EXCEPT AS NOTED					
TOLERANCE	VALUE	BALING		APPR	[Signature]
RES	±1%	OHMS	1/4W		
CAP	±20%				

TITLE		CONTROL DATA	NORMANDALE DIVISION
E. O. T. THRESHOLD DETECTOR		19333	C 54112200
TYPE 1CFV/ACFV		LOOK IDENT	DRAWING NUMBER
			CD 8

REVISION RECORD			
REV	ECO	DESCRIPTION	DATE
A	PE23000	RELEASED	7/29/71
B	PE29414	ADD DIODE 7CR4	10/1/71

SB	10/1/71	1-NR
----	---------	------

SHEET REVISION STATUS		1	
DRAWING NUMBER		C 54112200	
DRAWING NUMBER		19333	
DRAWING NUMBER		8	
DRAWING NUMBER		1	
DRAWING NUMBER		1	

SHEET NO.		DRAWING ZONE	
SH 2	C 2		

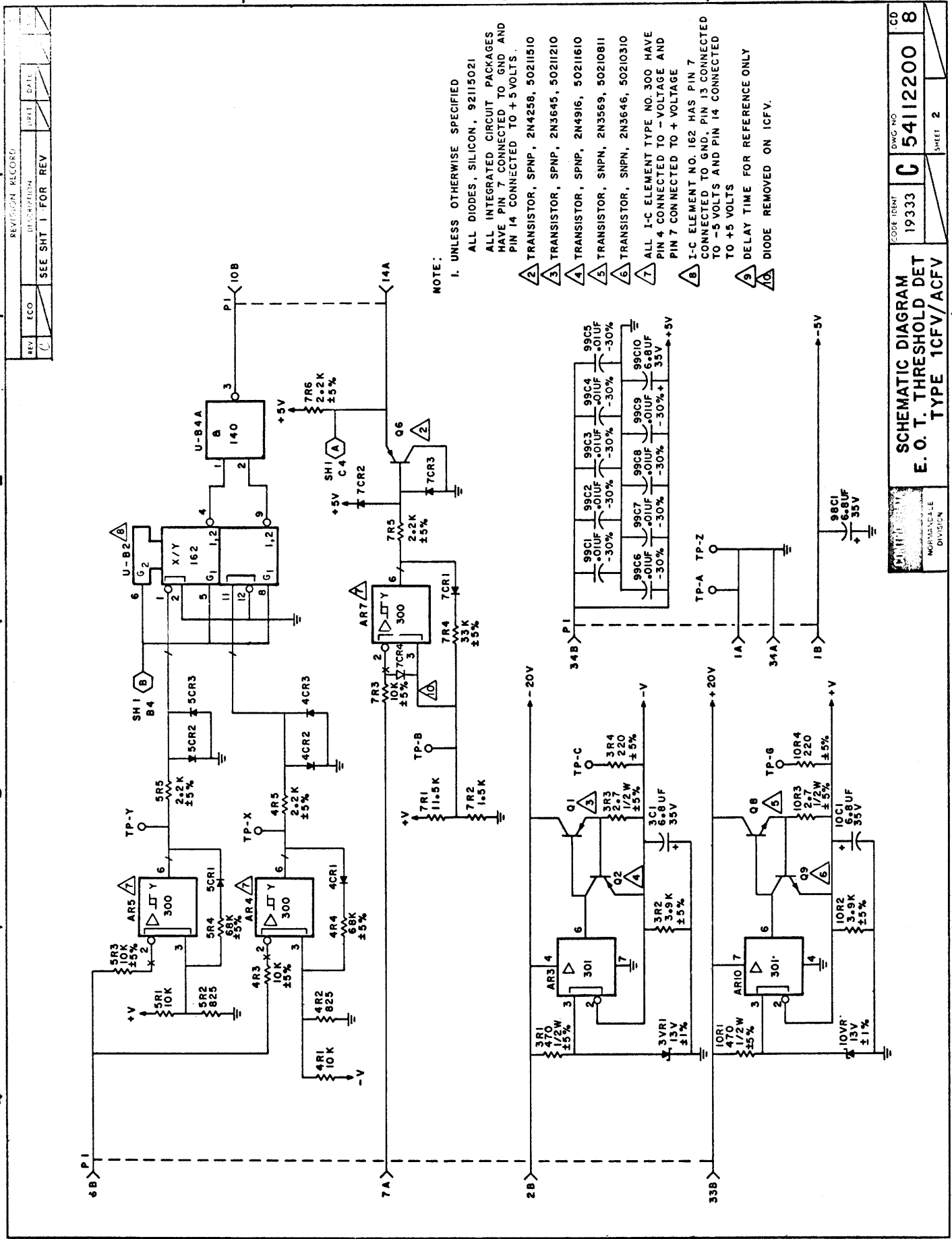

NOTE:

1. UNLESS OTHERWISE SPECIFIED ALL DIODES, SILICON, 92115021
- ALL INTEGRATED CIRCUIT PACKAGES HAVE PIN 7 CONNECTED TO GND AND PIN 14 CONNECTED TO +5 VOLTS.
2. TRANSISTOR, SPNP, 2N4258, 50211510
3. TRANSISTOR, SPNP, 2N3645, 50211210
4. TRANSISTOR, SPNP, 2N4916, 50211610
5. TRANSISTOR, SNPN, 2N3569, 50210811
6. TRANSISTOR, SNPN, 2N3646, 50210310
7. ALL I-C ELEMENT TYPE NO. 300 HAVE PIN 4 CONNECTED TO -VOLTAGE AND PIN 7 CONNECTED TO +VOLTAGE
8. I-C ELEMENT NO. 162 HAS PIN 7 CONNECTED TO GND, PIN 13 CONNECTED TO -5 VOLTS AND PIN 14 CONNECTED TO +5 VOLTS
9. DELAY TIME FOR REFERENCE ONLY
10. DIODE REMOVED ON ICFV.

REV	ECO	DESCRIPTION	DATE
		SEE SHT 1 FOR REV	
REVISION RECORD		CODE IDENT	DWG NO
		19333	C 54112200
			SHEET 2
		SCHEMATIC DIAGRAM	
		E. O. T. TYPE 1CFV/ACFV	
		CD	8

B54112200

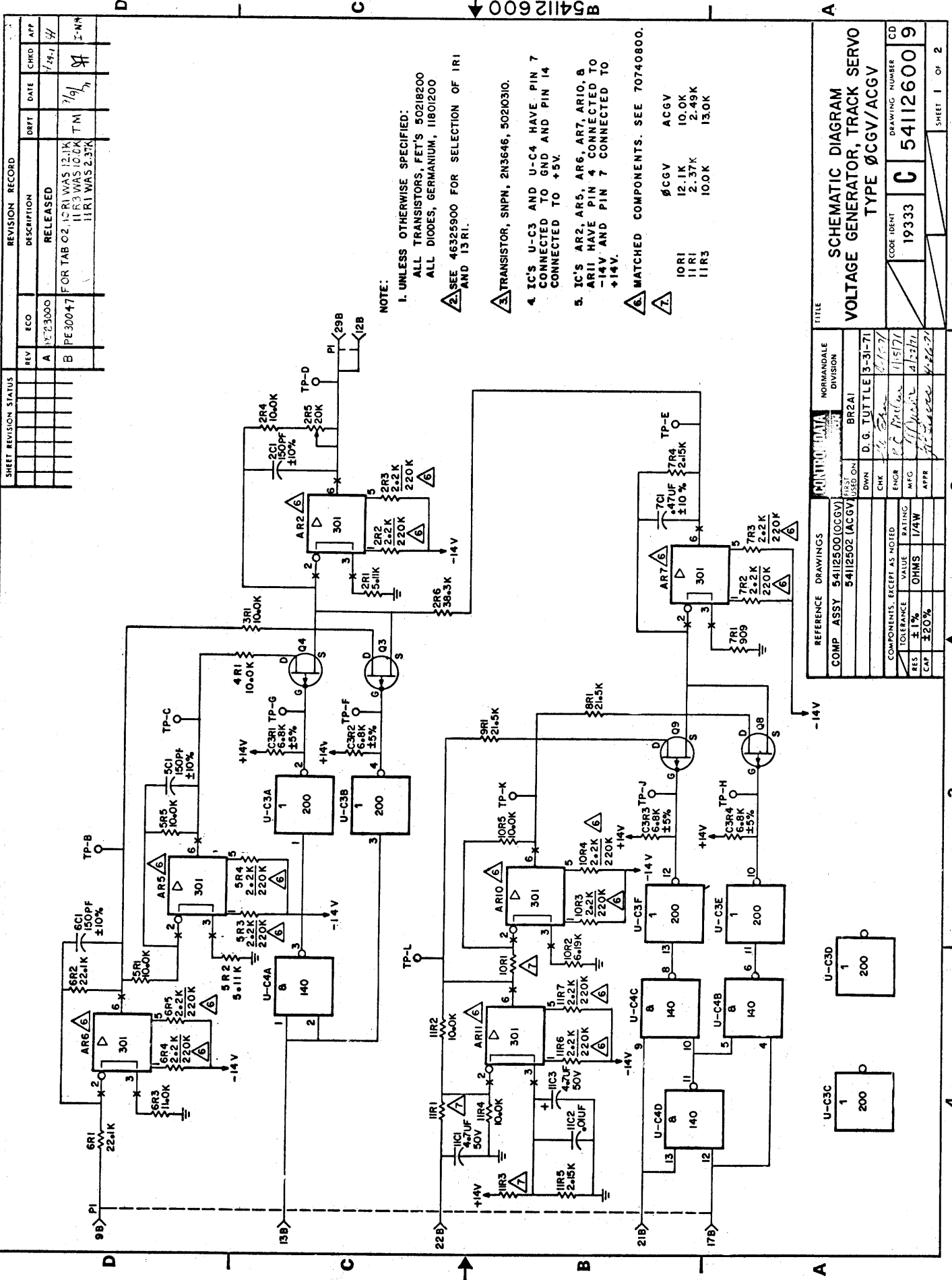

NOTE:
 1. UNLESS OTHERWISE SPECIFIED:
 ALL TRANSISTORS, FET'S 50218200
 ALL DIODES, GERMANIUM, 11801200
 2. SEE 46325900 FOR SELECTION OF IRI
 AND 13RI.

- 3. TRANSISTOR, SNPN, 2N3646, 50210310.
- 4. IC'S U-C3 AND U-C4 HAVE PIN 7 CONNECTED TO GND AND PIN 14 CONNECTED TO +5V.
- 5. IC'S AR2, AR5, AR6, AR7, AR10, 8 AR11 HAVE PIN 4 CONNECTED TO -14V AND PIN 7 CONNECTED TO +14V.
- 6. MATCHED COMPONENTS. SEE 70740800.
- 7.

ØCGV	ACGV
IRI	12.1K
IRI	10.0K
IIR3	2.37K
IIR3	10.0K
IIR3	13.0K

REV	ECO	DESCRIPTION	DRFT	DATE	CHKD	APP
A	23000	RELEASED				
B	PE30047	FOR TAB 02, IIR3 WAS 12.1K IIR3 WAS 10.0K IIR1 WAS 2.37K		7/9/71		

TITLE		NORMANDALE DIVISION	
COMP ASSY 54112502 (ACGV)		BR2A1	
REFERENCE DRAWINGS	COMPONENTS, EXCEPT AS NOTED	VALUES	RATING
RES ±1%	RES ±1%	OHMS	1/4W
CAP ±20%	CAP ±20%		
SCHEMATIC DIAGRAM		COCK IDENT	DRAWING NUMBER
VOLTAGE GENERATOR, TRACK SERVO		19333	C 54112600
TYPE 0CGV/ACGV			9
		SHEET 1	OF 2

1
2
3
4

1
2
3
4

1
2
3
4

1
2
3
4

B54112600

1
2
3
4

1
2
3
4

1
2
3
4

1
2
3
4

REVISION RECORD					
REV	ECO	DESCRIPTION	DATE	CHKD	APP
B		SEE SHT 1 FOR REV			

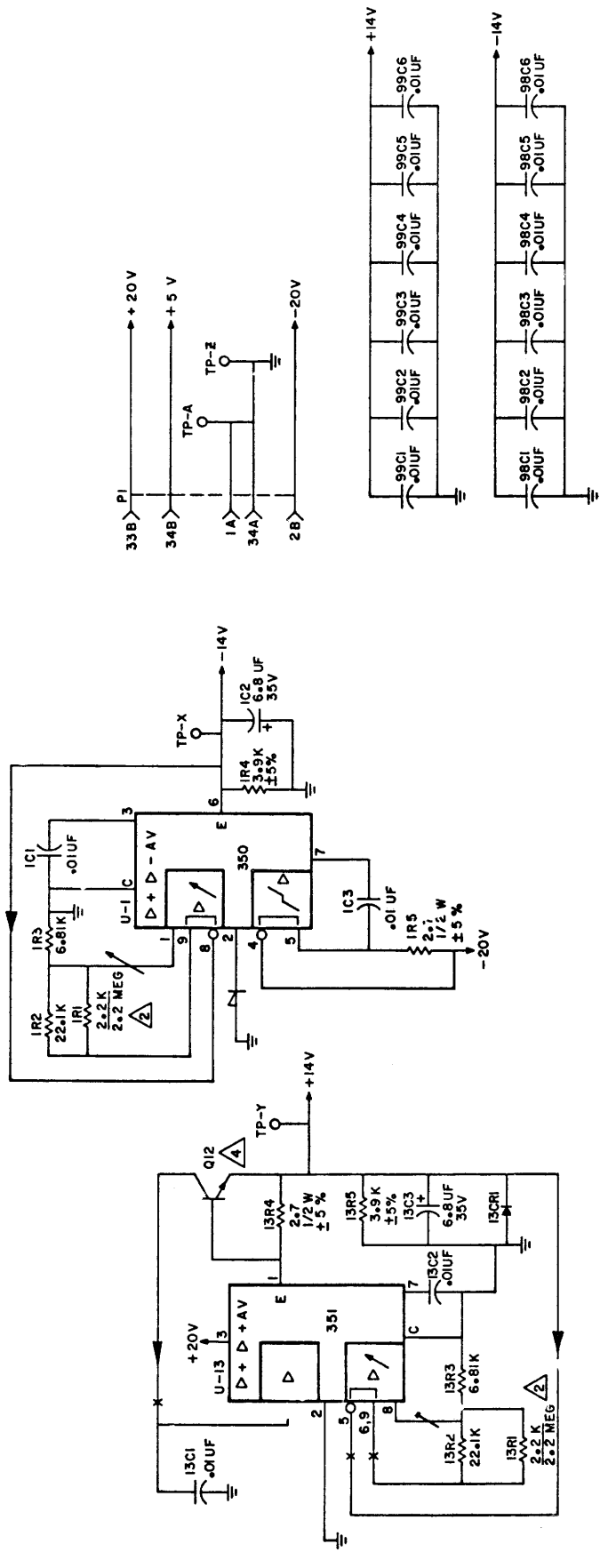

CD	DWG NO	54112600	9
19333	CODE IDENT	C	54112600
SCHEMATIC DIAGRAM		VOLTAGE GENERATOR,	
TRACK SERVO		TYPE 0CGV/ACGV	
CONTROL DATA		NORMANDEALE DIVISION	
SHEET 2		1	

SEE SH/ FOR REVISION

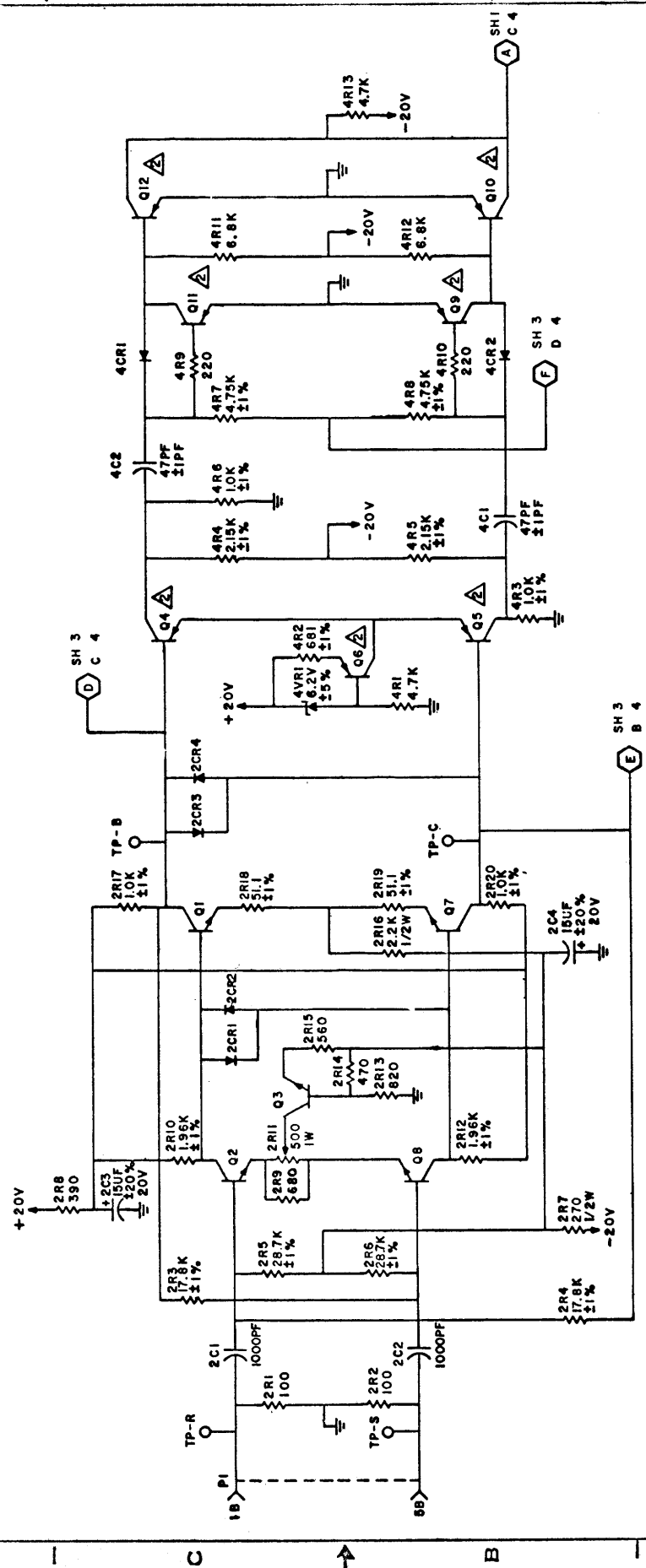

CD	1
C	54115400
15233	2
SCHEMATIC DIAGRAM READ RECOVERY TYPE 0CPV	

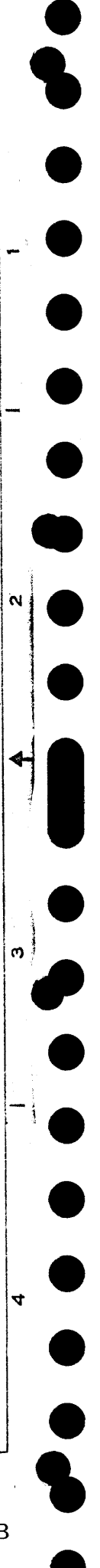

REVISION RECORD	
REV	DESCRIPTION
B	SEE SH I FOR REVISIONS

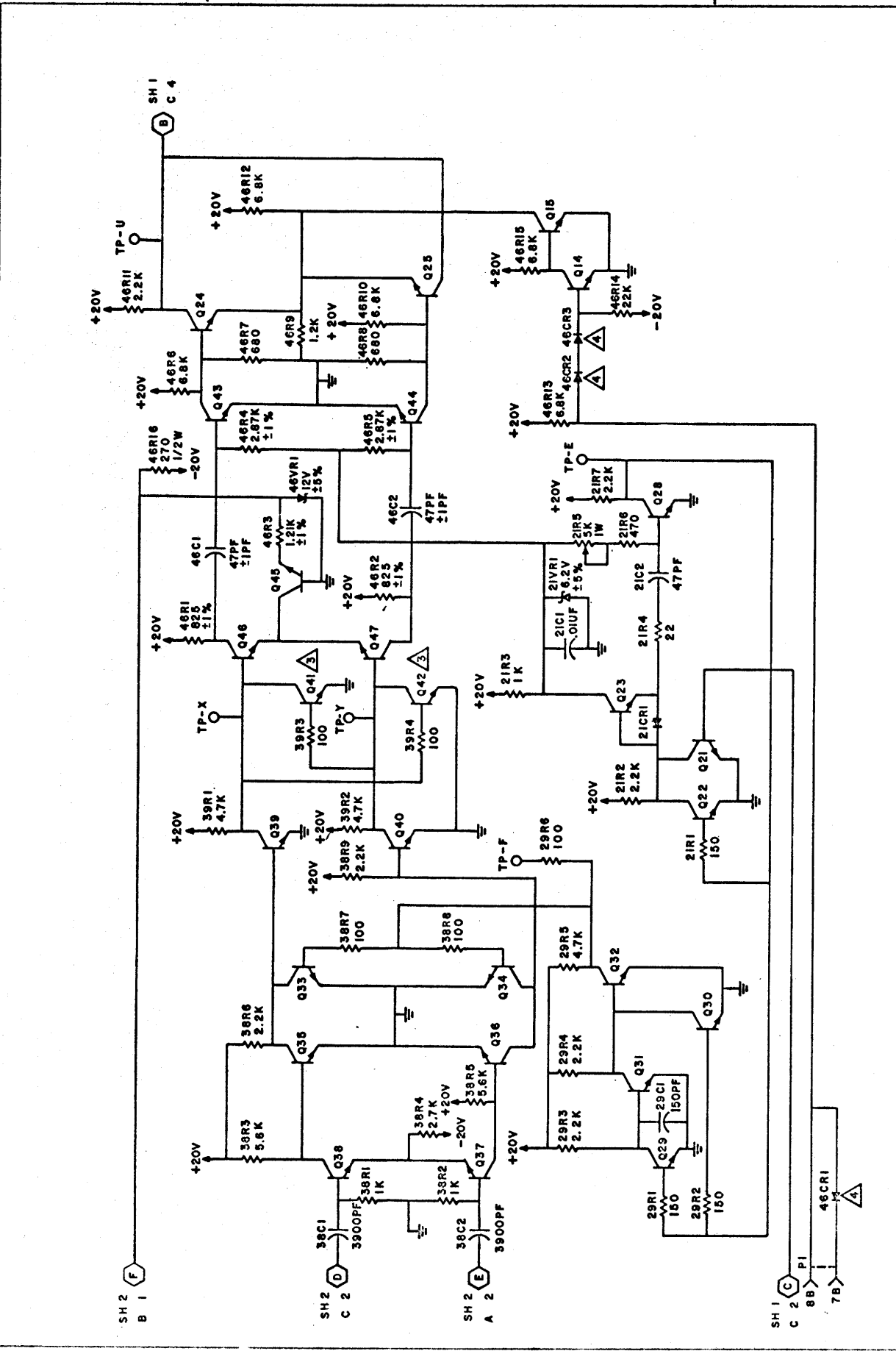

SCHEMATIC DIAGRAM		54115400	
READ RECOVERY		3	
TYPE 0CPV		1	

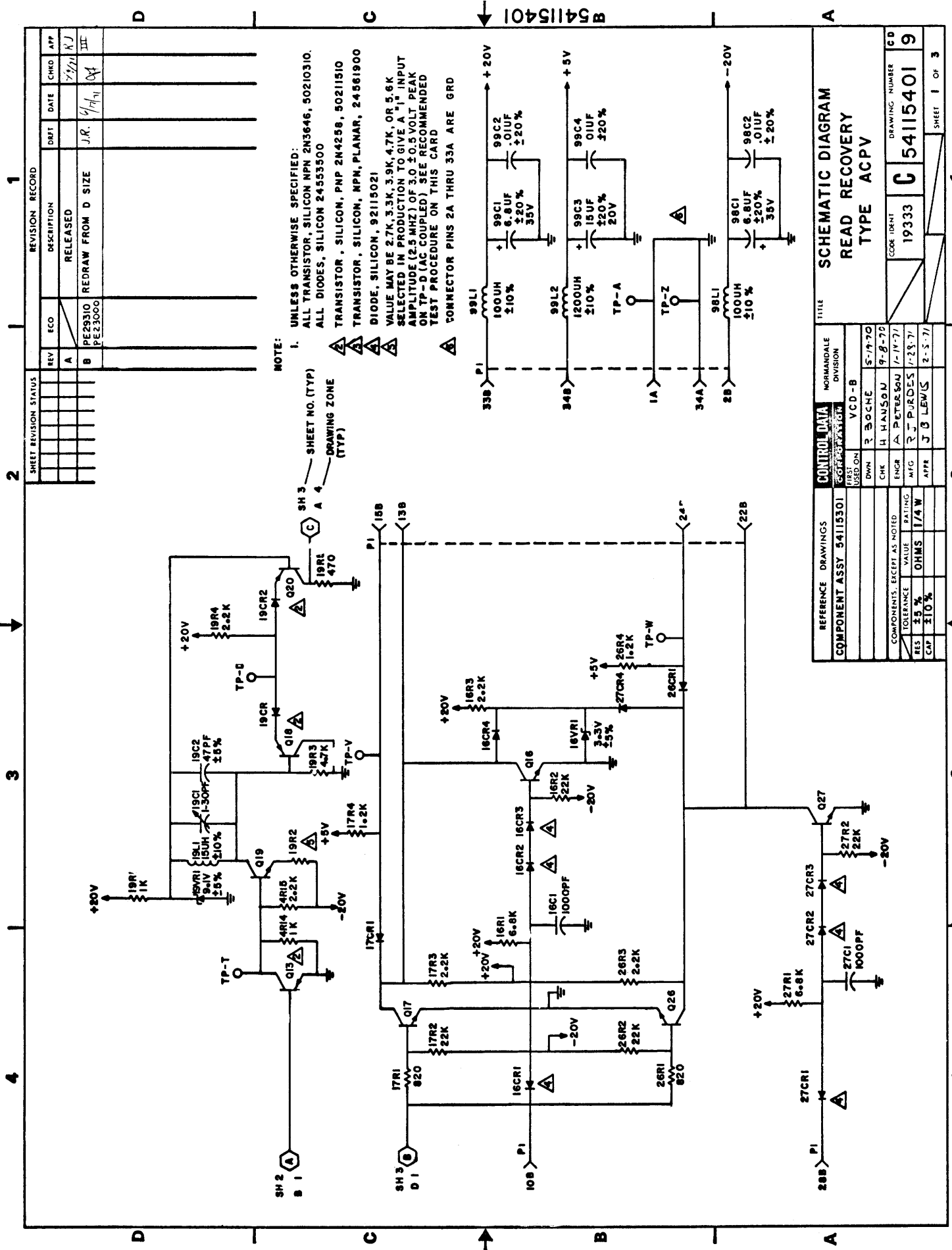

NOTE: 1. UNLESS OTHERWISE SPECIFIED:
 ALL TRANSISTOR, SILICON NPN 2N3646, 50210310.
 ALL DIODES, SILICON 24553500
 TRANSISTOR - SILICON, PNP 2N4258, 50211510
 DIODE, SILICON, 92115021
 VALUE MAY BE 2.7K, 3.3K, 3.9K, 4.7K, OR 5.6K
 SELECTED IN PRODUCTION TO GIVE A π INPUT
 AMPLITUDE (2.5 MHZ) OF 3.0 \pm 0.5 VOLT PEAK
 ON TP-D (AC COUPLED) SEE RECOMMENDED
 TEST PROCEDURE ON THIS CARD
 CONNECTOR PINS 2A THRU 33A ARE GRD

SHEET REVISION STATUS		REVISION RECORD		REV	ECO	DESCRIPTION	DRFT	DATE	CHKD	APP
1		1		A		RELEASED		7/22/71	AJ	
2		2		B	PE29310	REDRAW FROM D SIZE	J.R.	7/17/71		III
3					PE23000					

REFERENCE DRAWINGS		CONTROL DATA		NORMANDALE DIVISION		TITLE	
COMPONENT ASSY 54115301		54115301		VCD - B		SCHEMATIC DIAGRAM	
FIRST USED ON		DWN		P. BOCHÉ		READ RECOVERY	
CHK		H. HANSON		5-19-70		TYPE ACVP	
ENGR		A. PETERSON		9-8-70		CODE IDENT	
MFG		P. PURDES		7-14-71		DRAWING NUMBER	
APPR		J. B. LEWIS		2-5-71		19333	
TOLERANCE		VALUE		RATING		DRAWING NUMBER	
RES 25%		OHMS 1/4 W				54115401	
CAP 10%						CD	
						9	
						SHEET 1 OF 3	

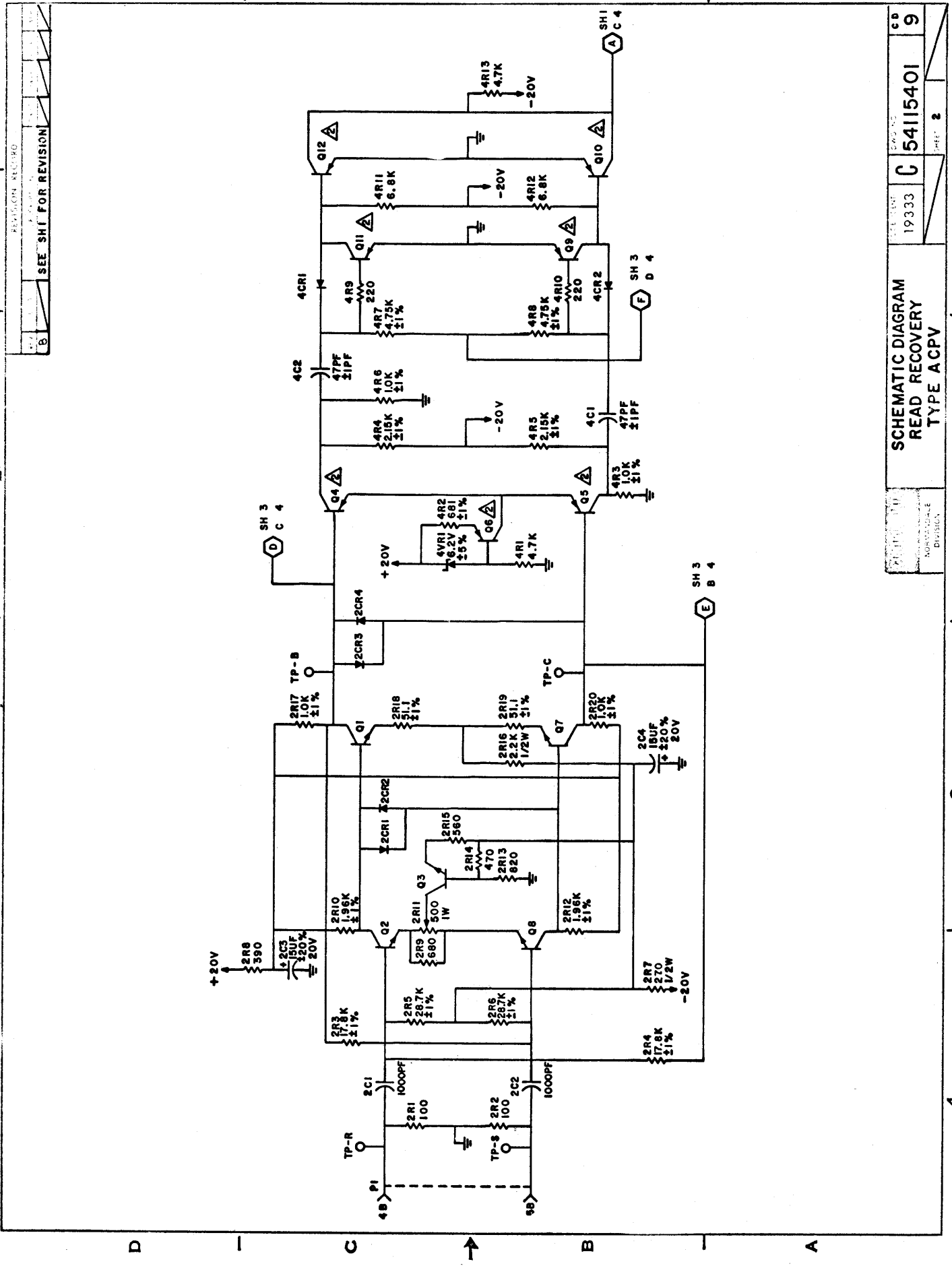

DATE DESIGNED	19333	DATE REVISION	C	WORKING DRAWING	54115401	CD	9
DESIGNED BY		DRAWN BY		CHECKED BY		APPROVED BY	
REVISION		REVISION		REVISION		REVISION	
1		2		3		4	

SCHEMATIC DIAGRAM
READ RECOVERY
TYPE ACVP

SEE SH 1 FOR REVISION

B 54115401

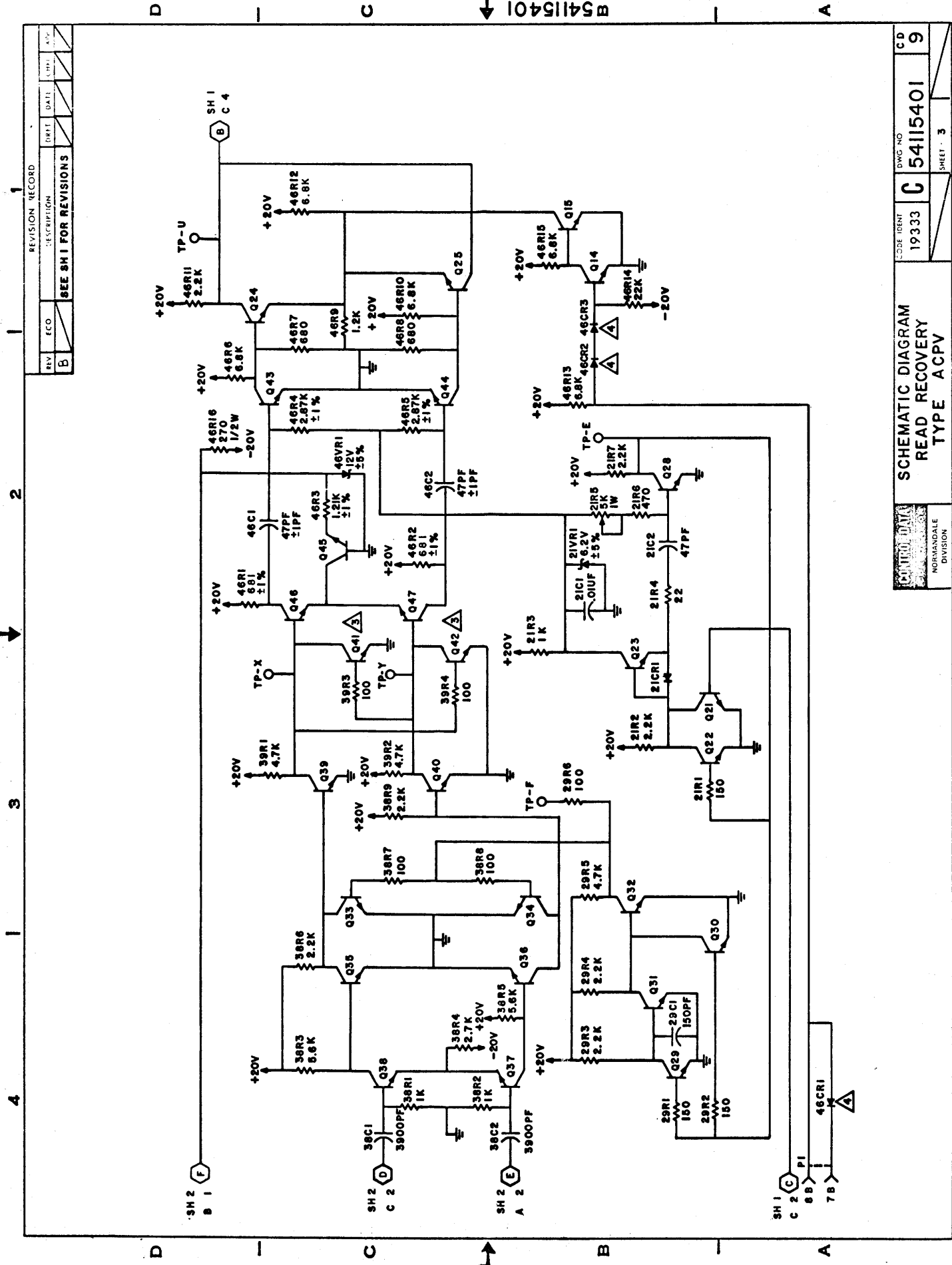

REV	ECO	DESCRIPTION	DATE	INIT	APP
B		SEE SH 1 FOR REVISIONS			

CONTROL DATA		NORMANDALE DIVISION	
SCHEMATIC DIAGRAM		READ RECOVERY	
TYPE ACPV		SHEET - 3	
CODE IDENT	DWG NO	CD	9
19333	C 54115401		

B 54115401

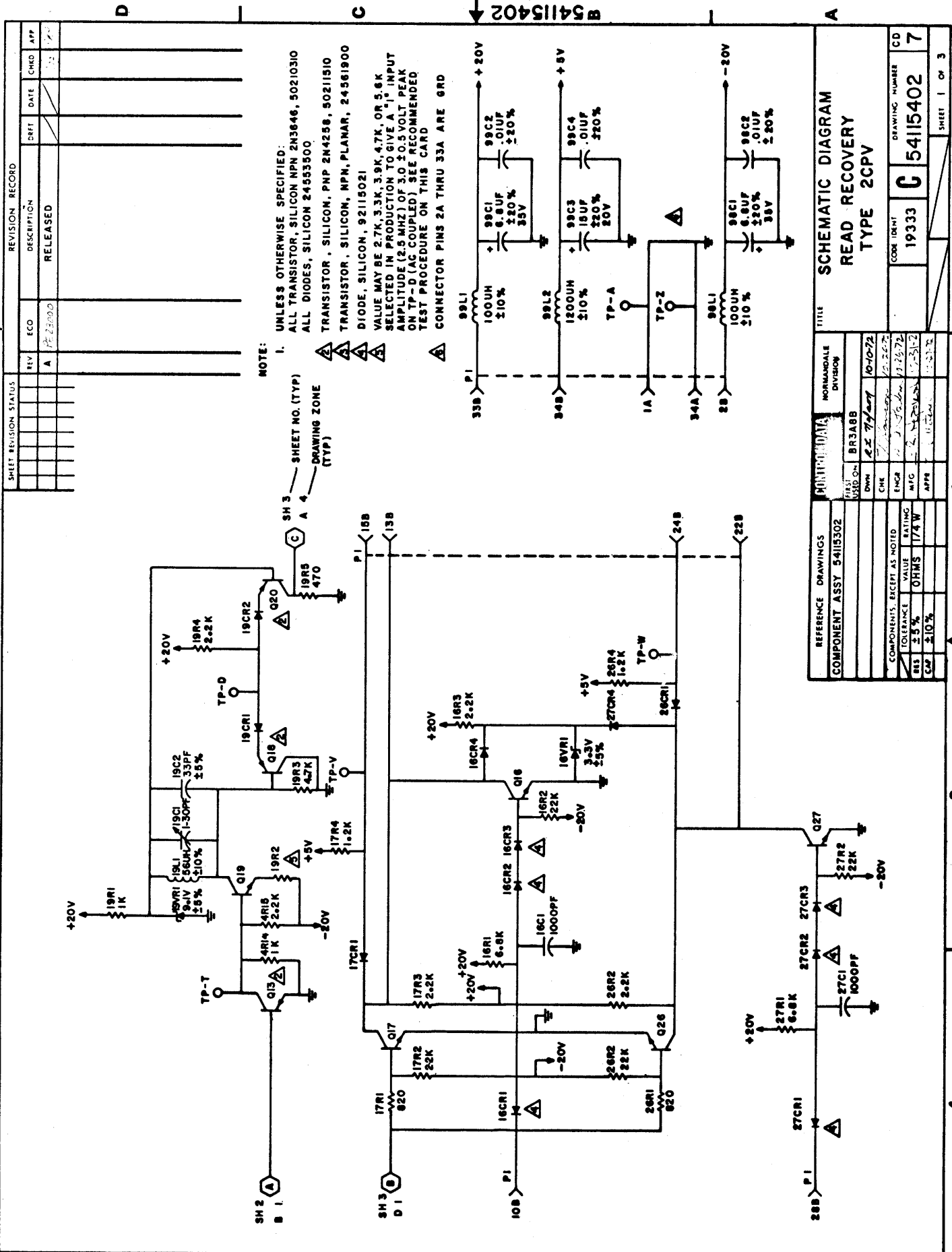

NOTE:

- UNLESS OTHERWISE SPECIFIED:
 ALL TRANSISTOR, SILICON NPN 2N3646, 50210310
 ALL DIODES, SILICON 24583500
 TRANSISTOR, SILICON, PNP 2N4258, 50211510
 TRANSISTOR, SILICON, NPN, PLANAR, 24581900
 DIODE, SILICON, 92115021
 VALUE MAY BE 2.7K, 3.3K, 3.9K, 4.7K, OR 5.6K
 SELECTED IN PRODUCTION TO GIVE A₁ INPUT
 AMPLITUDE (2.5 MHZ) OF 3.0 ±0.5 VOLT PEAK
 ON TP-B (AC COUPLED) SEE RECOMMENDED
 TEST PROCEDURE ON THIS CARD
 CONNECTOR PINS 2A THRU 33A ARE GRD

SHEET REVISION STATUS		REVISION RECORD			
REV	ECO	DESCRIPTION	CHG	DATE	CHKD
A	PC 23000	RELEASED			

REFERENCE DRAWINGS		NORMANDALE DIVISION	
COMPONENT ASSY	54115302	BR3ABB	10-10-72
FIRST USED ON:		CHK	10-10-72
DOWN		EMGR	10-10-72
UP		MFG	10-10-72
APP		APP	10-10-72

TITLE		DRAWING NUMBER	
SCHEMATIC DIAGRAM		54115402	
READ RECOVERY		19333	
TYPE 2CPV		CD	
CODE IDENT	19333	DRAWING NUMBER	7
SHEET 1 OF 3		HPD 1	

REV	ECO	DESCRIPTION	DATE	CHK	APP
A		SEE SH1 FOR REVISION			

REVISION RECORD					
1	2	3	4	1	2

B 54115402

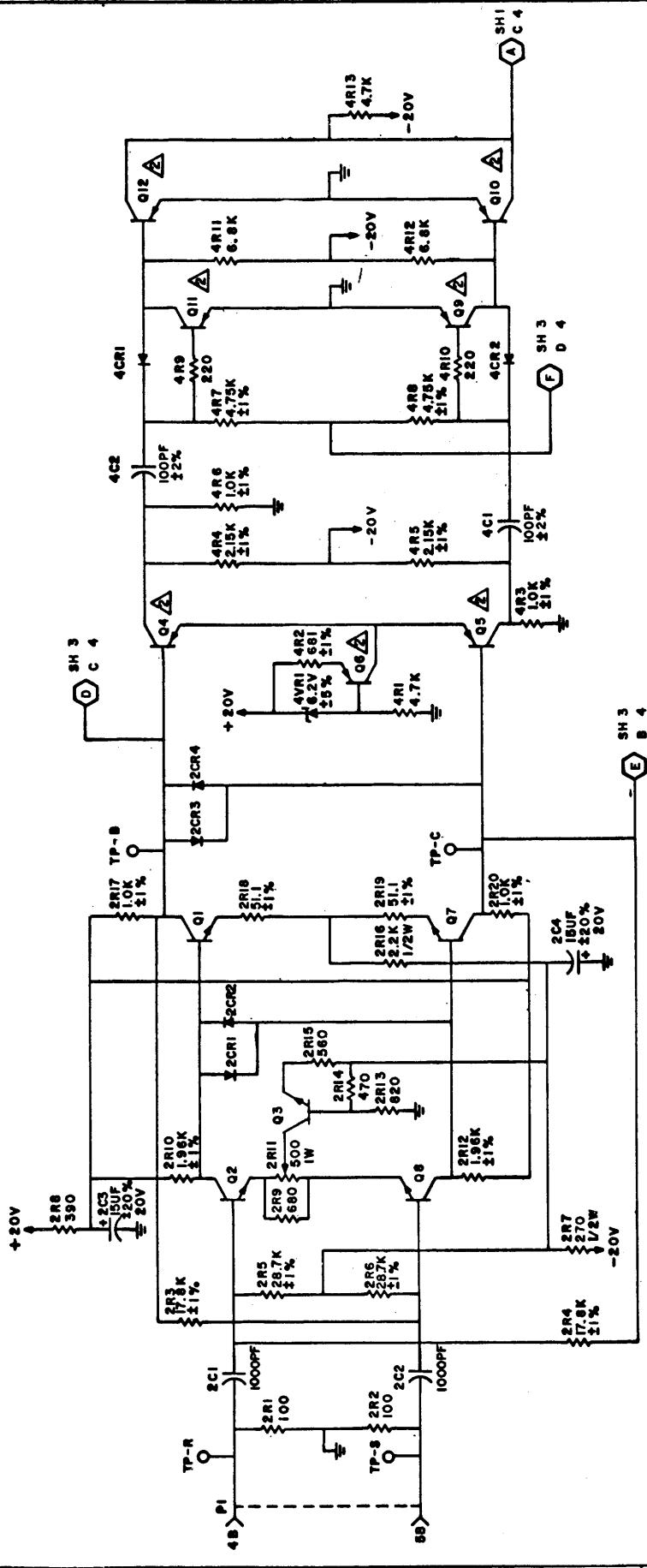

CONT'D. DATA	SCHEMATIC DIAGRAM	DWG NO	CD
DESCRIPTION	READ RECOVERY	19333	7
FORMANVILLE DIVISION	TYPE 2CPV	C	
		SHEET 2	

REVISION RECORD			
REV	ECO	DESCRIPTION	DRFT DATE
A		SEE SH 1 FOR REVISIONS	

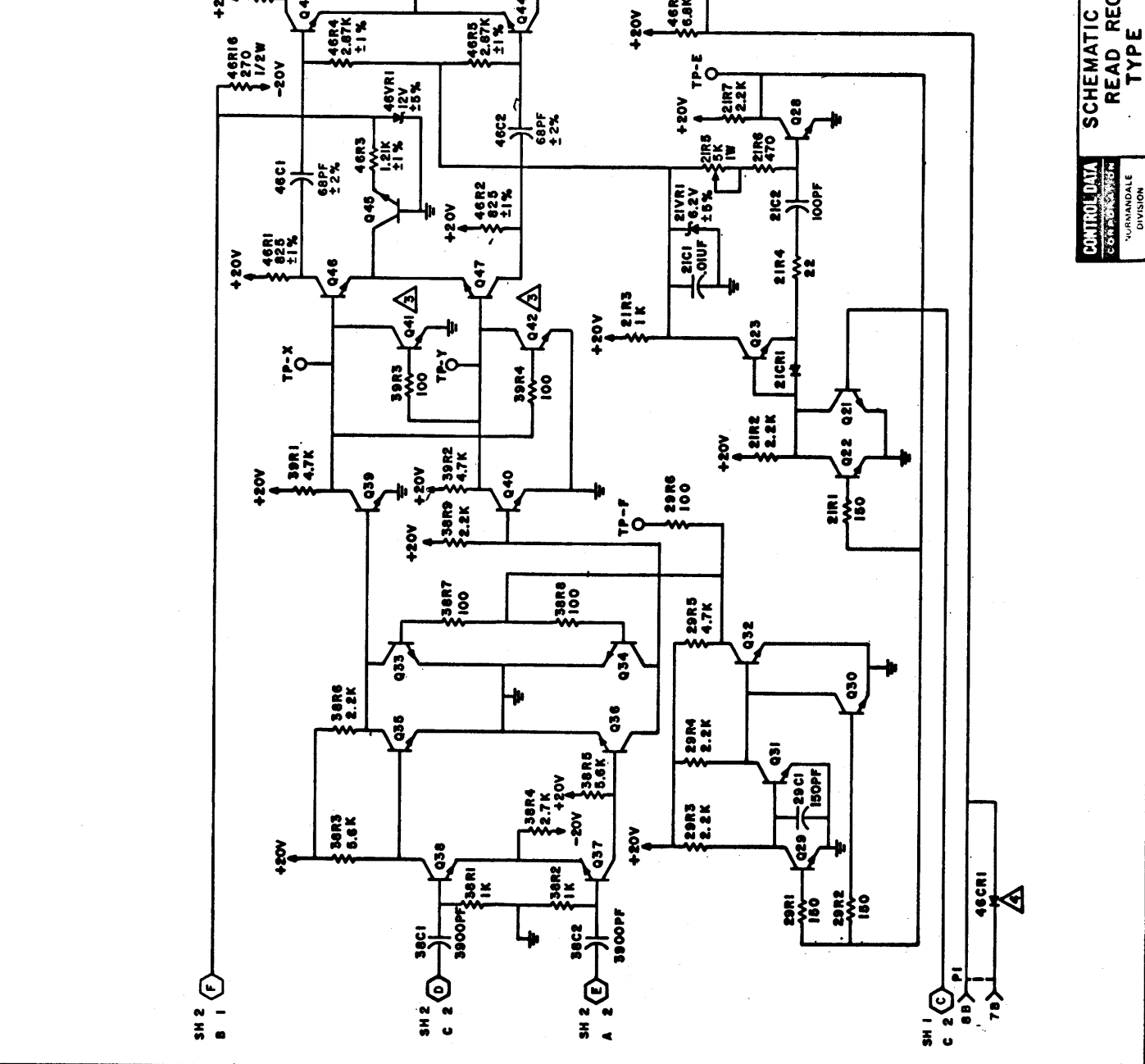

CONTROL DATA	SCHEMATIC DIAGRAM	CD
54115402	READ RECOVERY	7
19333	TYPE 2CPV	
MANHATTAN DIVISION		

54115402

19333

19333

MANHATTAN DIVISION

SCHEMATIC DIAGRAM

READ RECOVERY

TYPE 2CPV

CD 7

SHEET 3

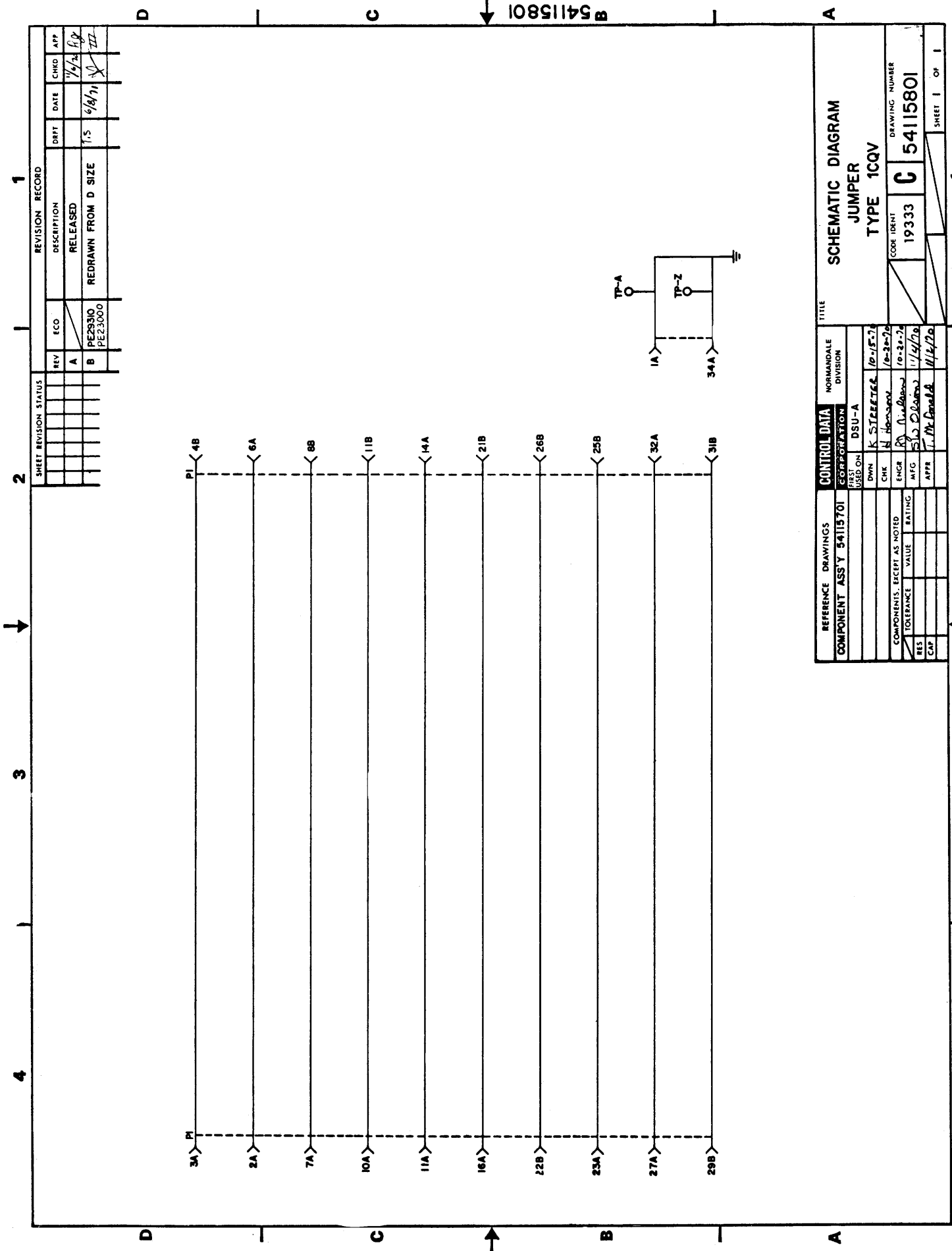

54115801

REVISION RECORD			
REV	ECO	DESCRIPTION	DATE
A		RELEASED	1/2/72
B		REDRAWN FROM D SIZE	6/8/71

SHEET REVISION STATUS	
REV	ECO
A	
B	

CHKD	APP
1/2/72	1/2/72
6/8/71	6/8/71

REFERENCE DRAWINGS COMPONENT ASSY 54115701	CONTROL DATA CORPORATION DSU-A	NORMANDE DIVISION	TITLE SCHEMATIC DIAGRAM JUMPER TYPE 1CQV
DWN K STREETER 10-15-71	CHK N HERRICK 10-20-71	ENGR R. J. DUBOIS 10-20-71	CODE IDENT 19333
RES CAP	APP J. Mc DONALD 11/16/72	MFG 5/2/72	DRAWING NUMBER 54115801
SHEET 1 OF 1			

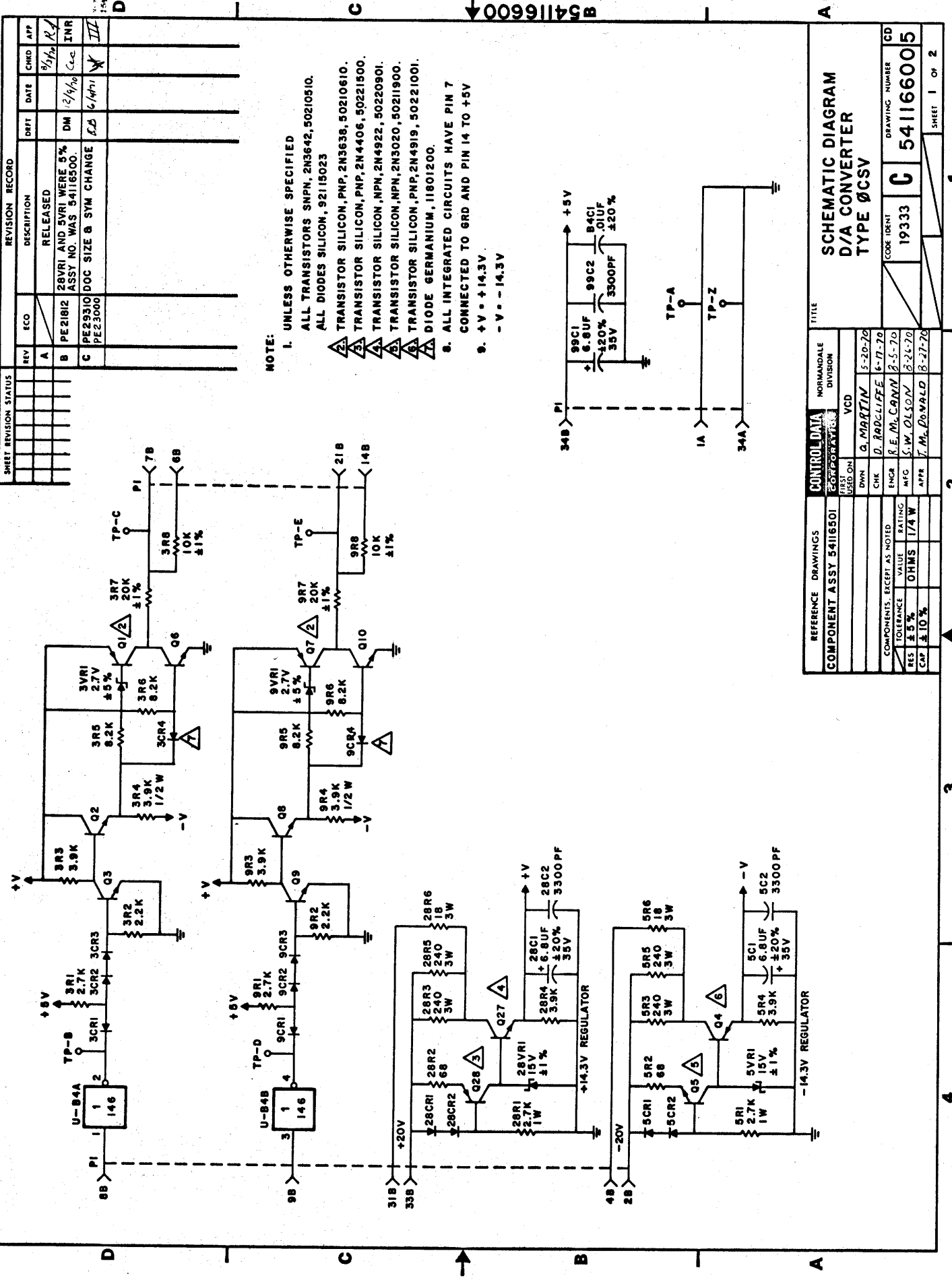

NOTE:

- UNLESS OTHERWISE SPECIFIED
ALL TRANSISTORS SNPN, 2N3642, 50210510.
ALL DIODES SILICON, 92115023
- TRANSISTOR SILICON, PNP, 2N3638, 50210610.
- TRANSISTOR SILICON, PNP, 2N4406, 50221500.
- TRANSISTOR SILICON, NPN, 2N4922, 50220901.
- TRANSISTOR SILICON, NPN, 2N3020, 50211900.
- TRANSISTOR SILICON, PNP, 2N4919, 50221001.
- DIODE GERMANIUM, 11801200.
- ALL INTEGRATED CIRCUITS HAVE PIN 7
CONNECTED TO GRD AND PIN 14 TO +5V
- +V = +14.3V
-V = -14.3V

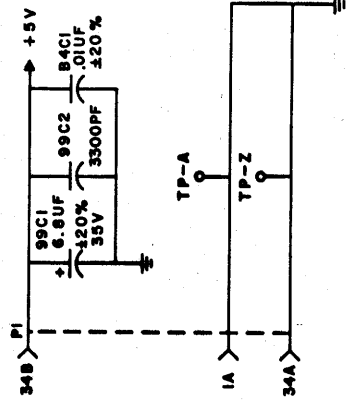

REVISION RECORD			
REV	ECO	DESCRIPTION	CHKD APP
A		RELEASED	9/1/70
B	PE21812	28VRI AND 5VRI WERE 5% ASSY NO. WAS 54116500.	DM 12/9/70
C	PE23100	DOC SIZE & SYM CHANGE	LD 6/4/71
D			

REFERENCE DRAWINGS		CONTROL DATA		NORMANDALE DIVISION		TITLE	
COMPONENT ASSY 54116501		CORPORATION		VCD		SCHEMATIC DIAGRAM D/A CONVERTER TYPE ØCSY	
DRN	D. MARTIN	CHK	D. RUDOLPH	5-20-70	19333	19333	19333
ENGR	R. E. Mc CANN	ENGR	S. W. OLSON	6-17-70	19333	19333	19333
MFG		MFG		8-5-70	19333	19333	19333
APPR	T. M. DONALD	APPR		8-27-70	19333	19333	19333
COMPONENTS, EXCEPT AS NOTED		TOLERANCE		VALUE		RATING	
RES ± 5%		OHMS		1/4W			
CAP ± 10%							
DRAWING NUMBER		DRAWING NUMBER		DRAWING NUMBER		DRAWING NUMBER	
541166005		541166005		541166005		541166005	
SHEET 1 OF 2		SHEET 1 OF 2		SHEET 1 OF 2		SHEET 1 OF 2	

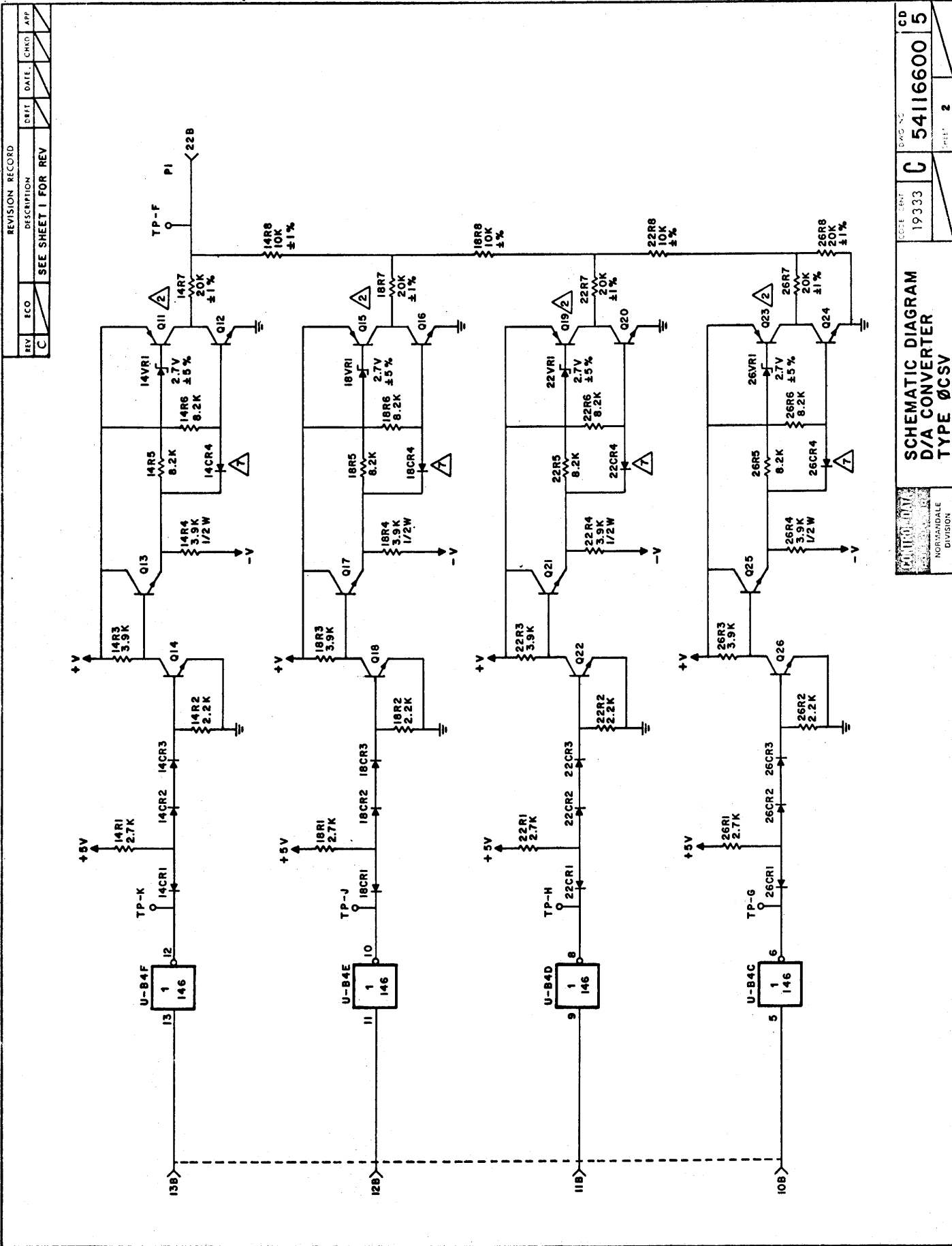

B54116600 ↓

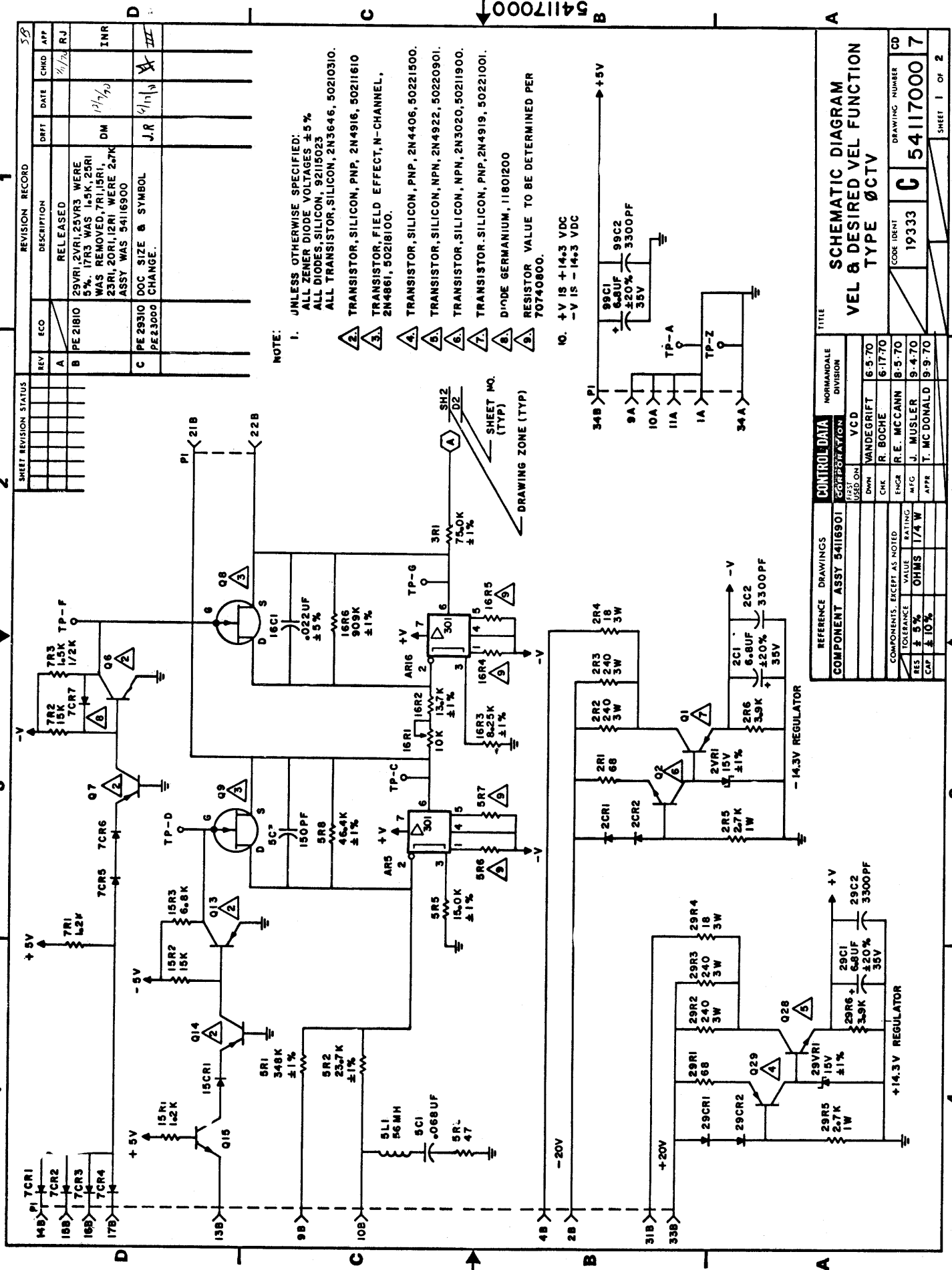

CONTROL DATA		NORMANDALE DIVISION	
COMPONENT ASSY 54116901	SCHEMATIC	VCD	
FIRST USED ON	DWN	WANDEGRIFT	6-5-70
CHK	R. BOCHE	ENGR	R. E. MCCANN 8-5-70
		MFC	J. MUSLER 9-4-70
		APPR	T. MC DONALD 9-9-70
COMPONENTS EXCEPT AS NOTED		TOLERANCE VALUE	
RES	± 5%	OHMS	1/4 W
CAP	± 10%		

REVISION RECORD		SHEET REVISION STATUS	
REV	ECO	DESCRIPTION	DATE
A		RELEASED	1/1/70
B	PE 21810	29VRI, 2VRI, 25VRS WERE 5% .17R3 WAS 1.5K, 25RI WAS REMOVED, 7RI, 15RI, 23RI, 20RI, 12RI WERE 2% DM ASSY WAS 54116900	1/1/70
C	PE 29310	DOC SIZE & SYMBOL PE23000 CHANGE.	1/1/70
D			

- NOTE:
- UNLESS OTHERWISE SPECIFIED:
ALL ZENER DIODE VOLTAGES ± 5%
ALL DIODES, SILICON, 92115023
ALL TRANSISTORS, SILICON, 2N3646, 50210310.
 - TRANSISTOR, SILICON, PNP, 2N4916, 50211610
 - TRANSISTOR, FIELD EFFECT, N-CHANNEL, 2N4861, 50218100.
 - TRANSISTOR, SILICON, PNP, 2N4406, 50221500.
 - TRANSISTOR, SILICON, NPN, 2N4922, 50220901.
 - TRANSISTOR, SILICON, NPN, 2N3020, 50211900.
 - TRANSISTOR, SILICON, PNP, 2N4919, 50221001.
 - DIODE GERMANIUM, 11801200
 - RESISTOR VALUE TO BE DETERMINED PER 70740800.

10. +V IS +14.3 VDC
-V IS -14.3 VDC

TITLE
SCHEMATIC DIAGRAM
VEL & DESIRED VEL FUNCTION
TYPE
ØCTV

19333
CORE IDENT

54117000
DRAWING NUMBER

1
SHEET 1 OF 2

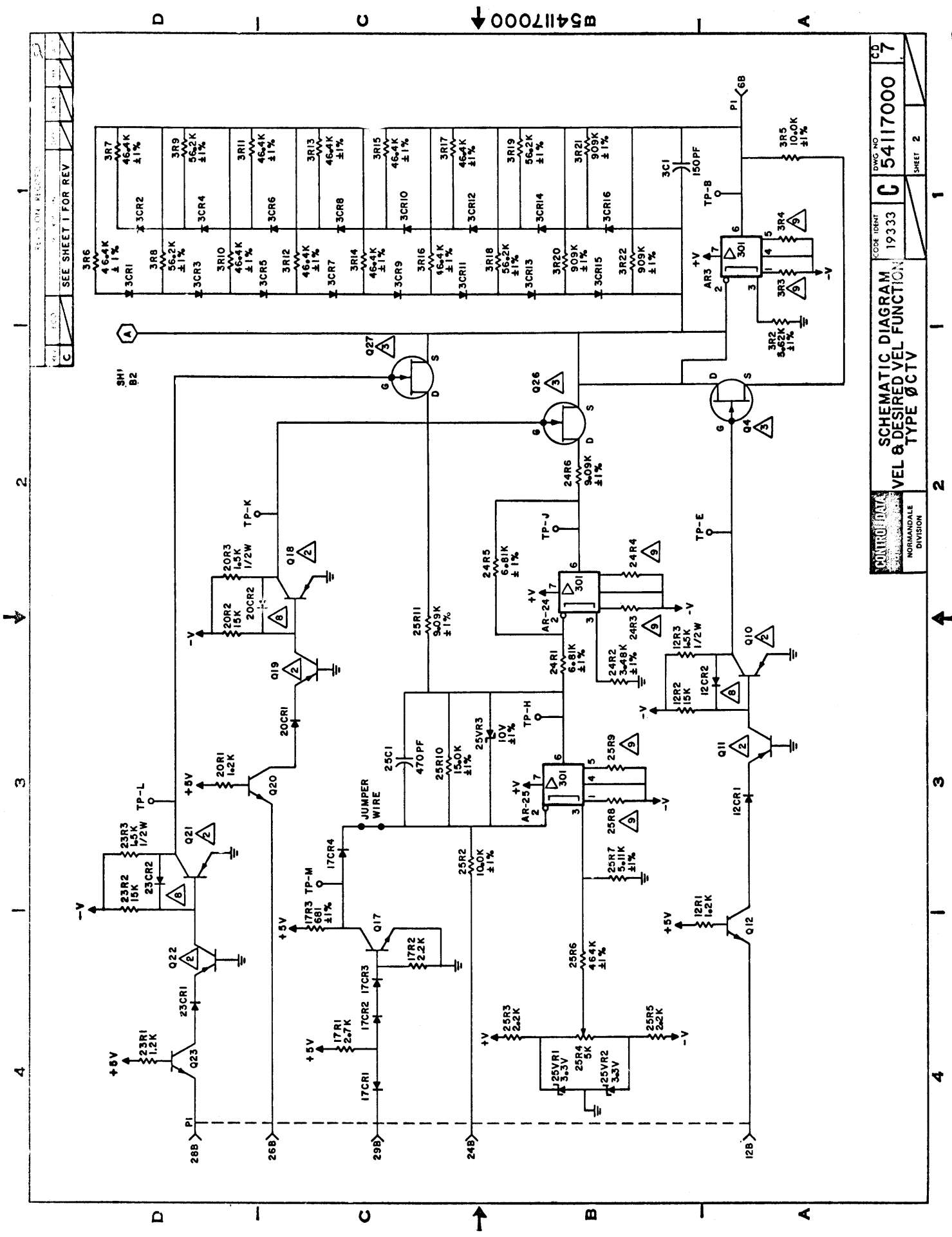

CONTROL DATA CORPORATION
NORMANVILLE DIVISION

SCHEMATIC DIAGRAM
VEL TYPE FUNCTION GENERATOR

DWG NO
54117000

CODE IDENT
19333

SHEET 2

54117000

A, B, C, D

A, B, C, D

1, 2, 3, 4

SEE SHEET 1 FOR REV

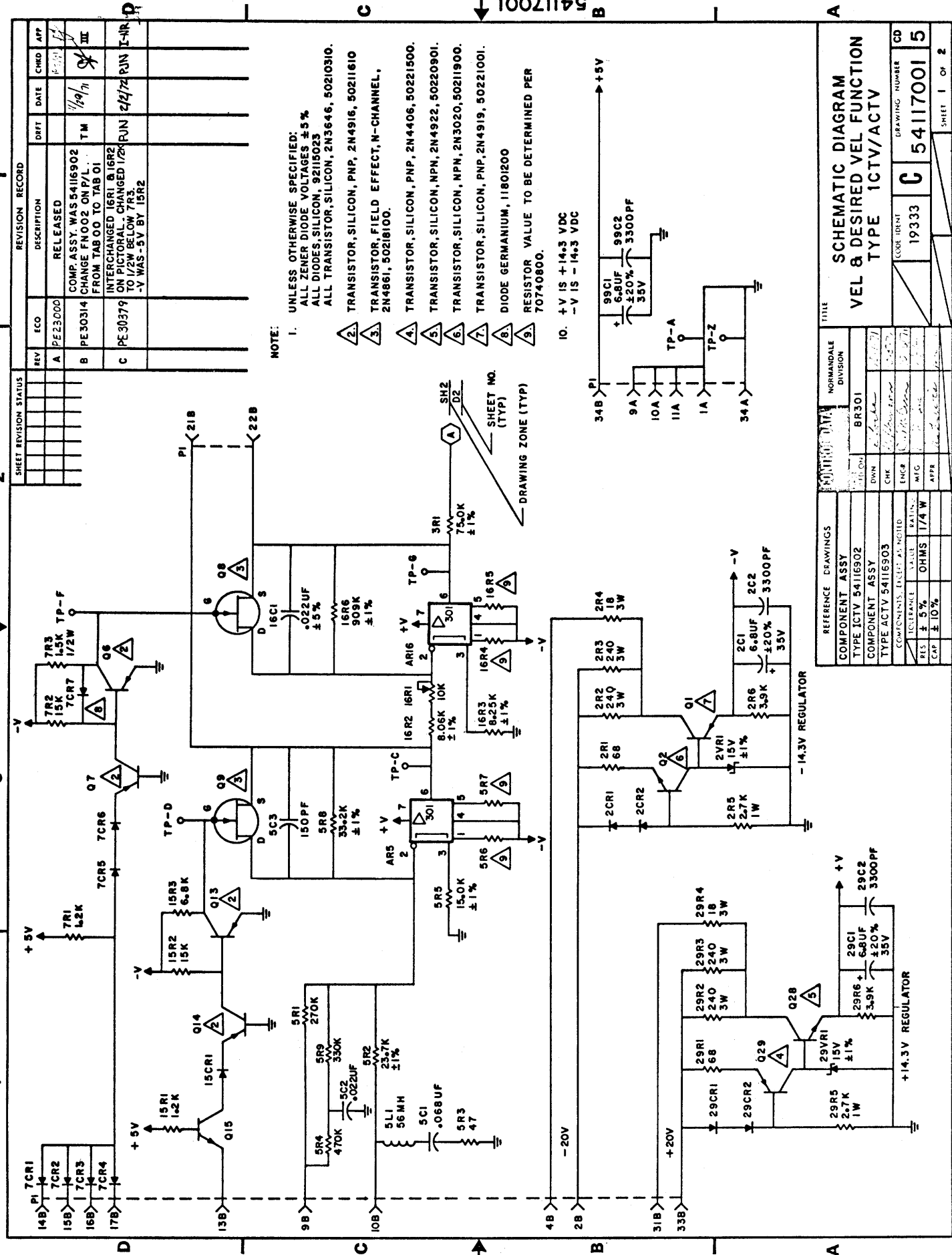

NOTE:

- UNLESS OTHERWISE SPECIFIED:
ALL ZENER DIODE VOLTAGES $\pm 5\%$
ALL DIODES, SILICON, 92115023
ALL TRANSISTORS, SILICON, 2N3646, 50210310.
- TRANSISTOR, SILICON, PNP, 2N4916, 50211610
- TRANSISTOR, FIELD EFFECT, N-CHANNEL,
2N4861, 50218100.
- TRANSISTOR, SILICON, PNP, 2N4406, 50221500.
- TRANSISTOR, SILICON, NPN, 2N4922, 50220901.
- TRANSISTOR, SILICON, NPN, 2N3020, 50211900.
- TRANSISTOR, SILICON, PNP, 2N4919, 50221001.
- DIODE GERMANIUM, 11801200
- RESISTOR VALUE TO BE DETERMINED PER
70740800.

10. +V IS ± 14.3 VDC
-V IS ± 14.3 VDC

REVISION RECORD		REV	ECO	DESCRIPTION	DRFT	DATE	CHKD	APP
A	PE23000			RELEASED				
B	PE30314			COMP ASSY WAS 54116902 CHANGE FNO02 ON P/L FROM TAB 00 TO TAB 01	TM	1/19/71		III
C	PE30379			INTERCHANGED 16R1 & 16R2 ON PICTORIAL. CHANGED 1/2W TO 1/2W BELOW 7R3. -V WAS -5V BY 15R2	RUN	12/12/72	RUN	I-NR

REFERENCE DRAWINGS	NORMANDALE DIVISION	
COMPONENT ASSY	BR301	
TYPE ICTV 54116902		
COMPONENT ASSY		
TYPE ACTV 54116903		
COMPONENTS EXCEPT AS NOTED		
TOLERANCE	VALUE	RATING
RES	$\pm 5\%$	OHMS 1/4 W
CAP	$\pm 10\%$	

TITLE		LOOK IDENT	DRAWING NUMBER	CD
SCHEMATIC DIAGRAM VEL & DESIRED VEL FUNCTION TYPE ICTV/ACTV		19333	C 54117001	5

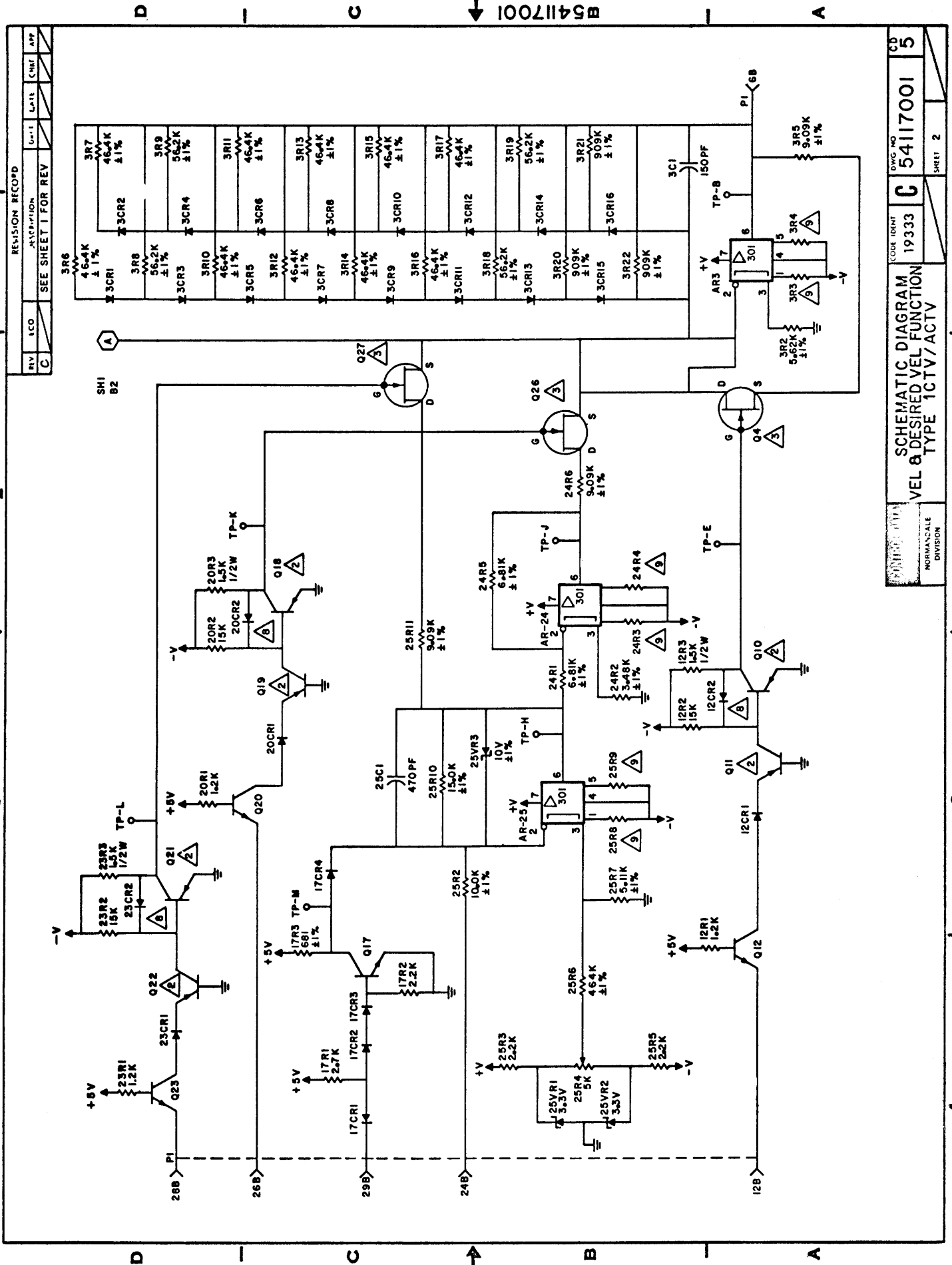

REVISION RECORD

REV	ICO	DESCRIPTION	DATE	CHK	APP
C		SEE SHEET 1 FOR REV			

DWG NO 54117001
 CODE IDENT 19333
 SCHEMATIC DIAGRAM
 VEL & DESIRED VEL FUNCTION
 TYPE 1CTV/ACTV
 NORMAL SCALE
 DIVISION
 SHEET 2

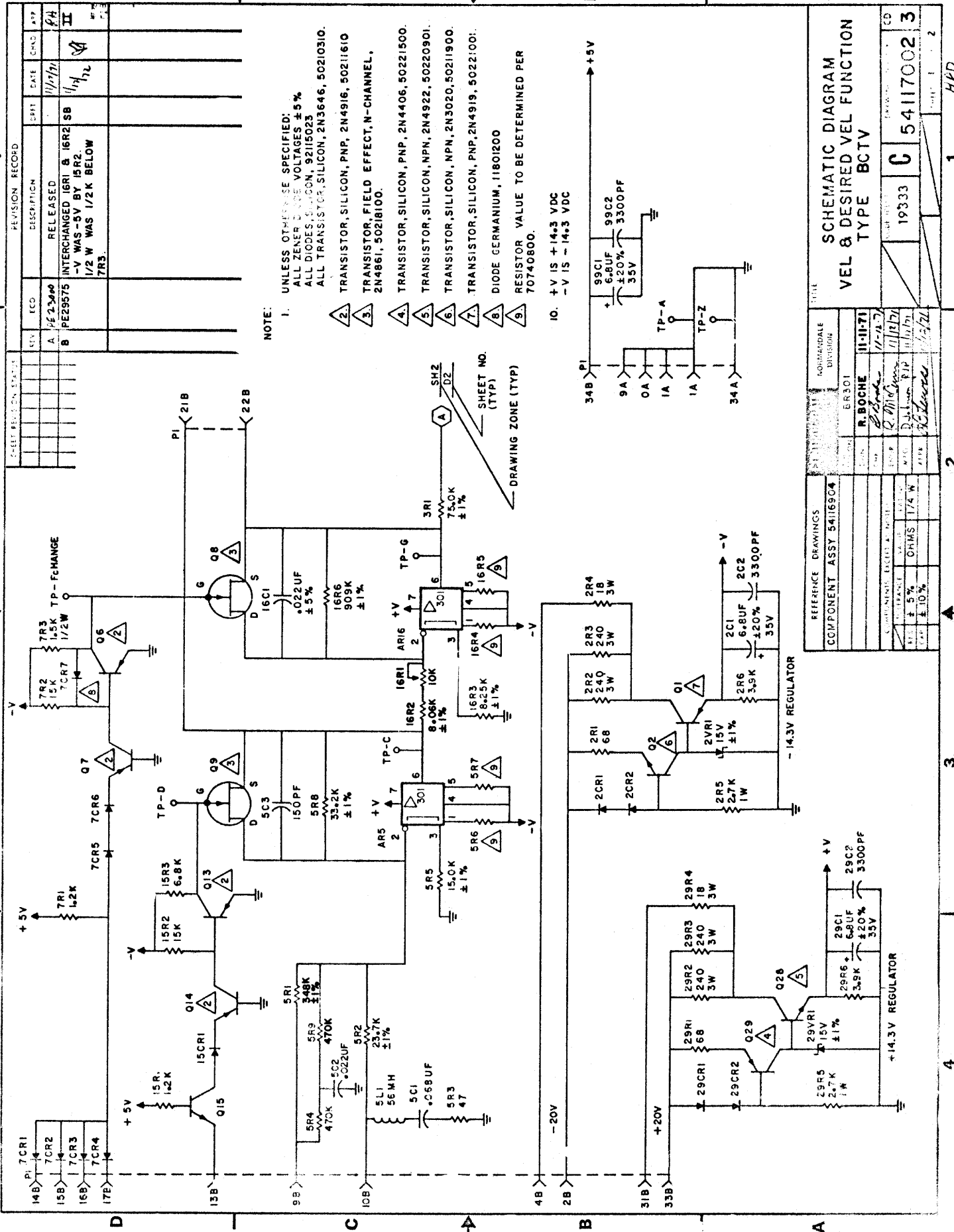

- NOTE:
1. UNLESS OTHERWISE SPECIFIED:
ALL ZENER DIODE VOLTAGES $\pm 5\%$
ALL DIODES SILICON, 92115023
ALL TRANSISTOR SILICON, 2N3646, 50210310.
 2. TRANSISTOR, SILICON, PNP, 2N4916, 50211610
 3. TRANSISTOR, FIELD EFFECT, N-CHANNEL, 2N4861, 50218100.
 4. TRANSISTOR, SILICON, PNP, 2N4406, 50221500.
 5. TRANSISTOR, SILICON, NPN, 2N4922, 50220901.
 6. TRANSISTOR, SILICON, NPN, 2N3020, 50211900.
 7. TRANSISTOR, SILICON, PNP, 2N4919, 50221001.
 8. DIODE GERMANIUM, 11801200
 9. RESISTOR VALUE TO BE DETERMINED PER 70740800.

10. +V IS ± 14.3 VDC
-V IS ± 14.3 VDC

REVISION RECORD		DATE	CHKD BY
NO.	ECO	DESCRIPTION	
A	PE23400	RELEASED	11/27/71
B	PE29575	INTERCHANGED 16R1 & 16R2 SB -V WAS -5V BY 15R2 1/2 W WAS 1/2 K BELOW 7R3.	11/17/71 11/12/71

REFERENCE DRAWINGS		COMPONENT ASSY 54117004	
NO.	DESCRIPTION	DATE	BY
1	54117002	11/17/71	R. BOCHÉ
2	54117003	11/17/71	R. BOCHÉ
3	54117004	11/17/71	R. BOCHÉ
4	54117005	11/17/71	R. BOCHÉ

SCHEMATIC DIAGRAM		VEL & DESIRED VEL FUNCTION	
TYPE	BCTV	19333	C 54117002 3
CD			

2-SHEET REVISION STATUS

PI 21B 22B 34B PI 9A 0A 1A 1A 34A

7R3 1.5K TP - FCHANGE 7R2 1.5K 7CR7 1/2W Q6 Q7 7CR5 7CR6 Q8 Q9 Q10

15R 1.2K 15R2 15K 15R3 6.8K Q13 Q14 Q15 5R1 3.3K 5R9 470K 5R2 23.7K 5L1 56MH 5C1 .022UF 5R3 47 5R4 470K 5C2 .022UF 5R5 15.0K 5R6 5R7 5R8 33.2K 5R9 16R1 10K 16R2 8.25K 16R3 8.25K 16R4 16R5 16R6 909K 16C1 .022UF 16C2 .022UF 16C3 .022UF 16C4 .022UF 16C5 .022UF 16C6 .022UF 16C7 .022UF 16C8 .022UF 16C9 .022UF 16C10 .022UF 16C11 .022UF 16C12 .022UF 16C13 .022UF 16C14 .022UF 16C15 .022UF 16C16 .022UF 16C17 .022UF 16C18 .022UF 16C19 .022UF 16C20 .022UF 16C21 .022UF 16C22 .022UF 16C23 .022UF 16C24 .022UF 16C25 .022UF 16C26 .022UF 16C27 .022UF 16C28 .022UF 16C29 .022UF 16C30 .022UF 16C31 .022UF 16C32 .022UF 16C33 .022UF 16C34 .022UF 16C35 .022UF 16C36 .022UF 16C37 .022UF 16C38 .022UF 16C39 .022UF 16C40 .022UF 16C41 .022UF 16C42 .022UF 16C43 .022UF 16C44 .022UF 16C45 .022UF 16C46 .022UF 16C47 .022UF 16C48 .022UF 16C49 .022UF 16C50 .022UF 16C51 .022UF 16C52 .022UF 16C53 .022UF 16C54 .022UF 16C55 .022UF 16C56 .022UF 16C57 .022UF 16C58 .022UF 16C59 .022UF 16C60 .022UF 16C61 .022UF 16C62 .022UF 16C63 .022UF 16C64 .022UF 16C65 .022UF 16C66 .022UF 16C67 .022UF 16C68 .022UF 16C69 .022UF 16C70 .022UF 16C71 .022UF 16C72 .022UF 16C73 .022UF 16C74 .022UF 16C75 .022UF 16C76 .022UF 16C77 .022UF 16C78 .022UF 16C79 .022UF 16C80 .022UF 16C81 .022UF 16C82 .022UF 16C83 .022UF 16C84 .022UF 16C85 .022UF 16C86 .022UF 16C87 .022UF 16C88 .022UF 16C89 .022UF 16C90 .022UF 16C91 .022UF 16C92 .022UF 16C93 .022UF 16C94 .022UF 16C95 .022UF 16C96 .022UF 16C97 .022UF 16C98 .022UF 16C99 .022UF 16C100 .022UF

2CR1 2CR2 2CR3 2CR4 2CR5 2CR6 2CR7 2CR8 2CR9 2CR10 2CR11 2CR12 2CR13 2CR14 2CR15 2CR16 2CR17 2CR18 2CR19 2CR20 2CR21 2CR22 2CR23 2CR24 2CR25 2CR26 2CR27 2CR28 2CR29 2CR30 2CR31 2CR32 2CR33 2CR34 2CR35 2CR36 2CR37 2CR38 2CR39 2CR40 2CR41 2CR42 2CR43 2CR44 2CR45 2CR46 2CR47 2CR48 2CR49 2CR50 2CR51 2CR52 2CR53 2CR54 2CR55 2CR56 2CR57 2CR58 2CR59 2CR60 2CR61 2CR62 2CR63 2CR64 2CR65 2CR66 2CR67 2CR68 2CR69 2CR70 2CR71 2CR72 2CR73 2CR74 2CR75 2CR76 2CR77 2CR78 2CR79 2CR80 2CR81 2CR82 2CR83 2CR84 2CR85 2CR86 2CR87 2CR88 2CR89 2CR90 2CR91 2CR92 2CR93 2CR94 2CR95 2CR96 2CR97 2CR98 2CR99 2CR100

29CR1 29CR2 29CR3 29CR4 29CR5 29CR6 29CR7 29CR8 29CR9 29CR10 29CR11 29CR12 29CR13 29CR14 29CR15 29CR16 29CR17 29CR18 29CR19 29CR20 29CR21 29CR22 29CR23 29CR24 29CR25 29CR26 29CR27 29CR28 29CR29 29CR30 29CR31 29CR32 29CR33 29CR34 29CR35 29CR36 29CR37 29CR38 29CR39 29CR40 29CR41 29CR42 29CR43 29CR44 29CR45 29CR46 29CR47 29CR48 29CR49 29CR50 29CR51 29CR52 29CR53 29CR54 29CR55 29CR56 29CR57 29CR58 29CR59 29CR60 29CR61 29CR62 29CR63 29CR64 29CR65 29CR66 29CR67 29CR68 29CR69 29CR70 29CR71 29CR72 29CR73 29CR74 29CR75 29CR76 29CR77 29CR78 29CR79 29CR80 29CR81 29CR82 29CR83 29CR84 29CR85 29CR86 29CR87 29CR88 29CR89 29CR90 29CR91 29CR92 29CR93 29CR94 29CR95 29CR96 29CR97 29CR98 29CR99 29CR100

29R1 29R2 29R3 29R4 29R5 29R6 29R7 29R8 29R9 29R10 29R11 29R12 29R13 29R14 29R15 29R16 29R17 29R18 29R19 29R20 29R21 29R22 29R23 29R24 29R25 29R26 29R27 29R28 29R29 29R30 29R31 29R32 29R33 29R34 29R35 29R36 29R37 29R38 29R39 29R40 29R41 29R42 29R43 29R44 29R45 29R46 29R47 29R48 29R49 29R50 29R51 29R52 29R53 29R54 29R55 29R56 29R57 29R58 29R59 29R60 29R61 29R62 29R63 29R64 29R65 29R66 29R67 29R68 29R69 29R70 29R71 29R72 29R73 29R74 29R75 29R76 29R77 29R78 29R79 29R80 29R81 29R82 29R83 29R84 29R85 29R86 29R87 29R88 29R89 29R90 29R91 29R92 29R93 29R94 29R95 29R96 29R97 29R98 29R99 29R100

29C1 29C2 29C3 29C4 29C5 29C6 29C7 29C8 29C9 29C10 29C11 29C12 29C13 29C14 29C15 29C16 29C17 29C18 29C19 29C20 29C21 29C22 29C23 29C24 29C25 29C26 29C27 29C28 29C29 29C30 29C31 29C32 29C33 29C34 29C35 29C36 29C37 29C38 29C39 29C40 29C41 29C42 29C43 29C44 29C45 29C46 29C47 29C48 29C49 29C50 29C51 29C52 29C53 29C54 29C55 29C56 29C57 29C58 29C59 29C60 29C61 29C62 29C63 29C64 29C65 29C66 29C67 29C68 29C69 29C70 29C71 29C72 29C73 29C74 29C75 29C76 29C77 29C78 29C79 29C80 29C81 29C82 29C83 29C84 29C85 29C86 29C87 29C88 29C89 29C90 29C91 29C92 29C93 29C94 29C95 29C96 29C97 29C98 29C99 29C100

29S1 29S2 29S3 29S4 29S5 29S6 29S7 29S8 29S9 29S10 29S11 29S12 29S13 29S14 29S15 29S16 29S17 29S18 29S19 29S20 29S21 29S22 29S23 29S24 29S25 29S26 29S27 29S28 29S29 29S30 29S31 29S32 29S33 29S34 29S35 29S36 29S37 29S38 29S39 29S40 29S41 29S42 29S43 29S44 29S45 29S46 29S47 29S48 29S49 29S50 29S51 29S52 29S53 29S54 29S55 29S56 29S57 29S58 29S59 29S60 29S61 29S62 29S63 29S64 29S65 29S66 29S67 29S68 29S69 29S70 29S71 29S72 29S73 29S74 29S75 29S76 29S77 29S78 29S79 29S80 29S81 29S82 29S83 29S84 29S85 29S86 29S87 29S88 29S89 29S90 29S91 29S92 29S93 29S94 29S95 29S96 29S97 29S98 29S99 29S100

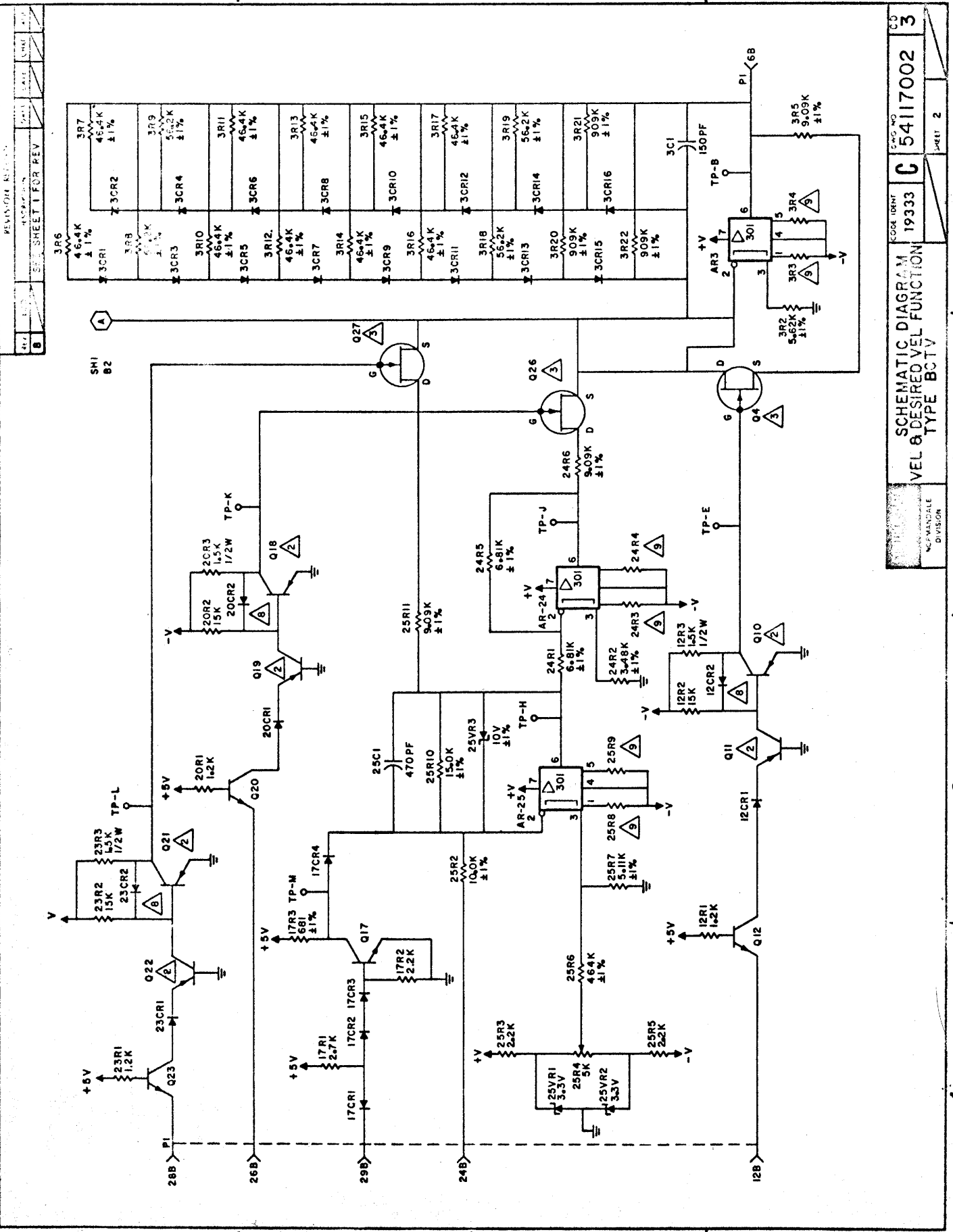

REV. 1
 SHEET 1 FOR REV.
 SCHEMATIC DIAGRAM
 VEL 8 TYPE BCTV
 CODE IDENT 19333
 C 54117002
 SHEET 2

B54117002

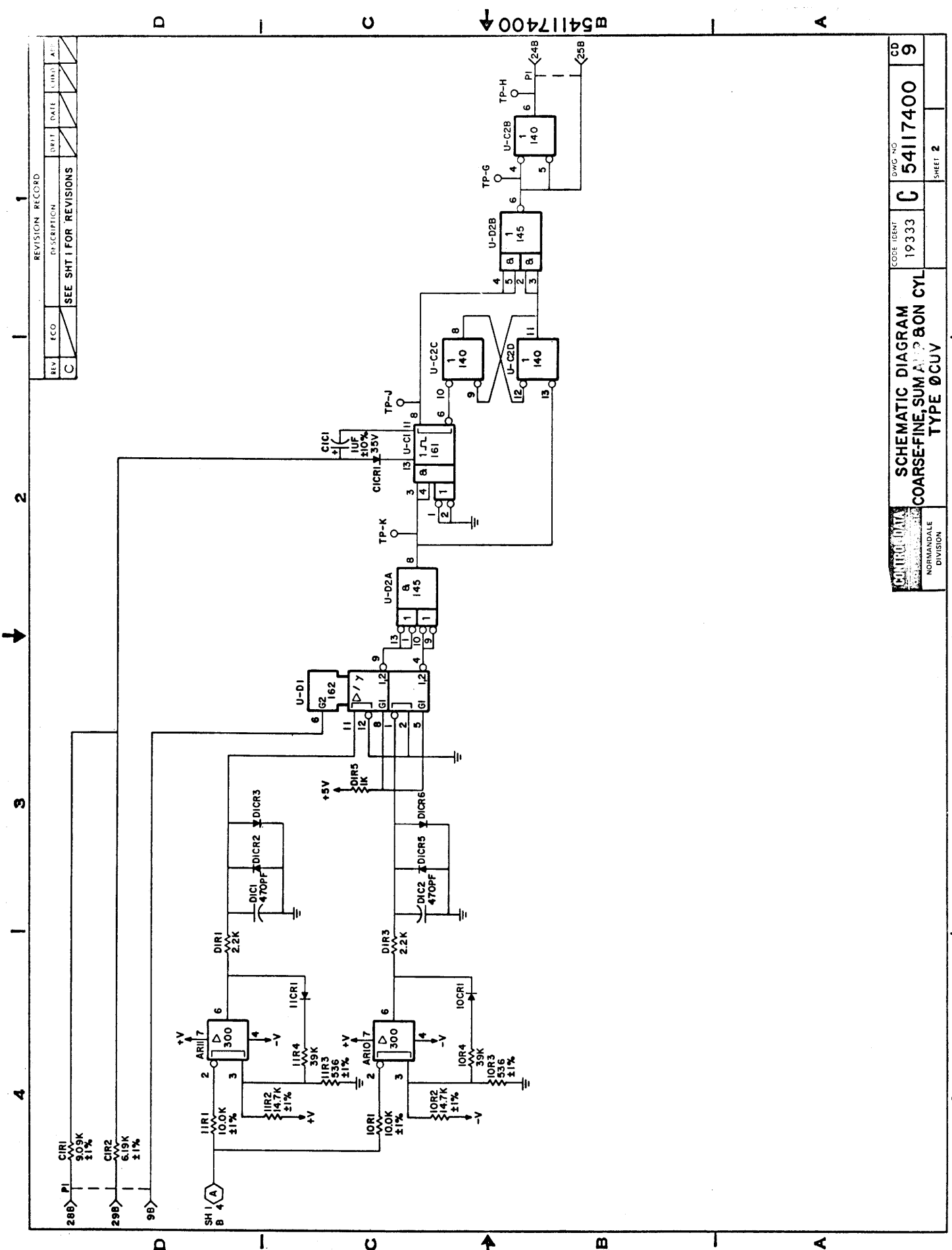

REV	ECO	DESCRIPTION	DATE	INITIALS
C		SEE SHT 1 FOR REVISIONS		

SCHEMATIC DIAGRAM		DWG NO	CD
COARSE-FINE SUM AMPLIFIER		C 54117400	9
TYPE DCUV		19333	
NORMANDALE DIVISION		SHEET 2	

B 54117400

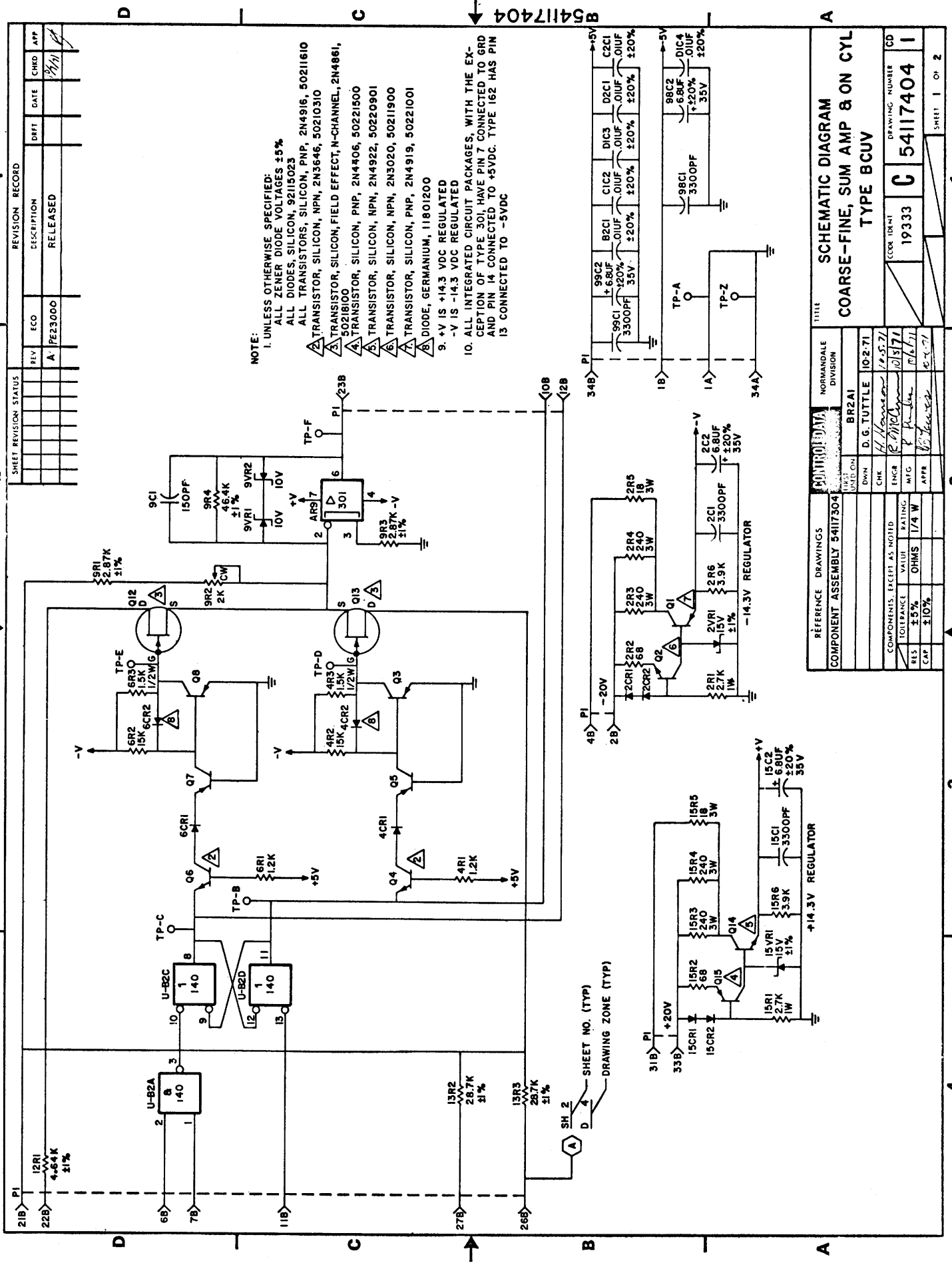

NOTE:

- UNLESS OTHERWISE SPECIFIED:
 ALL ZENER DIODE VOLTAGES $\pm 5\%$
 ALL DIODES, SILICON, 9215023
 ALL TRANSISTORS, SILICON, PNP, 2N4916, 50211610
 ALL TRANSISTORS, SILICON, NPN, 2N3646, 50210310
- TRANSISTOR, SILICON, FIELD EFFECT, N-CANAL, 2N4861, 50218100
- TRANSISTOR, SILICON, PNP, 2N4906, 50221500
- TRANSISTOR, SILICON, NPN, 2N4922, 50220901
- TRANSISTOR, SILICON, NPN, 2N3020, 50211900
- TRANSISTOR, SILICON, PNP, 2N4919, 50221001
- DIODE, GERMANIUM, 11801200

9. $+V$ IS $+14.3$ VDC REGULATED
 $-V$ IS -14.3 VDC REGULATED

10. ALL INTEGRATED CIRCUIT PACKAGES, WITH THE EXCEPTION OF TYPE 301 HAVE PIN 7 CONNECTED TO GND AND PIN 14 CONNECTED TO $+5$ VDC. TYPE 162 HAS PIN 13 CONNECTED TO -5 VDC

SHEET REVISION STATUS		REVISION RECORD	
REV	ECO	DESCRIPTION	DATE
A	FE23000	RELEASED	

REV	ECO	DESCRIPTION	DATE	CHKD	APP

REFERENCE DRAWINGS		NORMANDALE DIVISION	
COMPONENT ASSEMBLY 54117304	BR2A1	D. G. TUTTLE	10-2-71
DESIGN	CHK	ENG	10-15-71
10/10/71		10/13/71	
10/6/71		10/6/71	
10-9-71		10-9-71	

TITLE		SCHEMATIC DIAGRAM	
COARSE-FINE, SUM AMP 8 ON CYL		TYPE BCuY	
19333	19333	19333	19333
54117404	54117404	54117404	54117404
1	1	1	1

CONTROL DATA		SHEET NO. (TYP)	
DRAWING ZONE (TYP)		D 4	
SHEET NO. (TYP)		D 4	
DRAWING ZONE (TYP)		D 4	

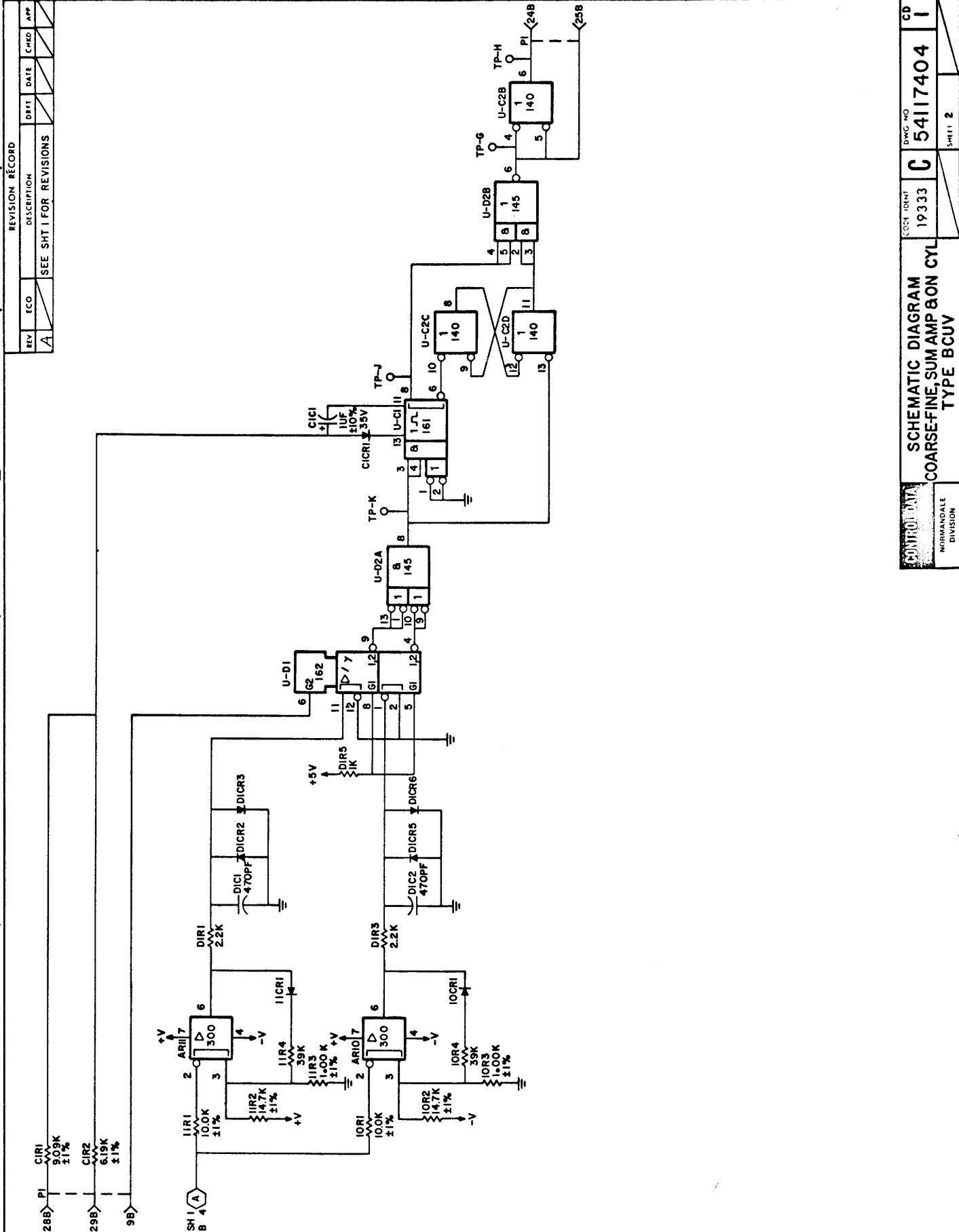

REV	ECO	DESCRIPTION	DEPT	DATE	CHKD	APP
A		SEE SHT 1 FOR REVISIONS				

REVISION RECORD

CONTROL DATA		NORMAN DALE DIVISION	
SCHEMATIC DIAGRAM COARSE-FINE, SUM AMP 80N CYL TYPE BCUV			
CD	DWG NO	COST IDENT	SHEET 2
	54117404	19333	1

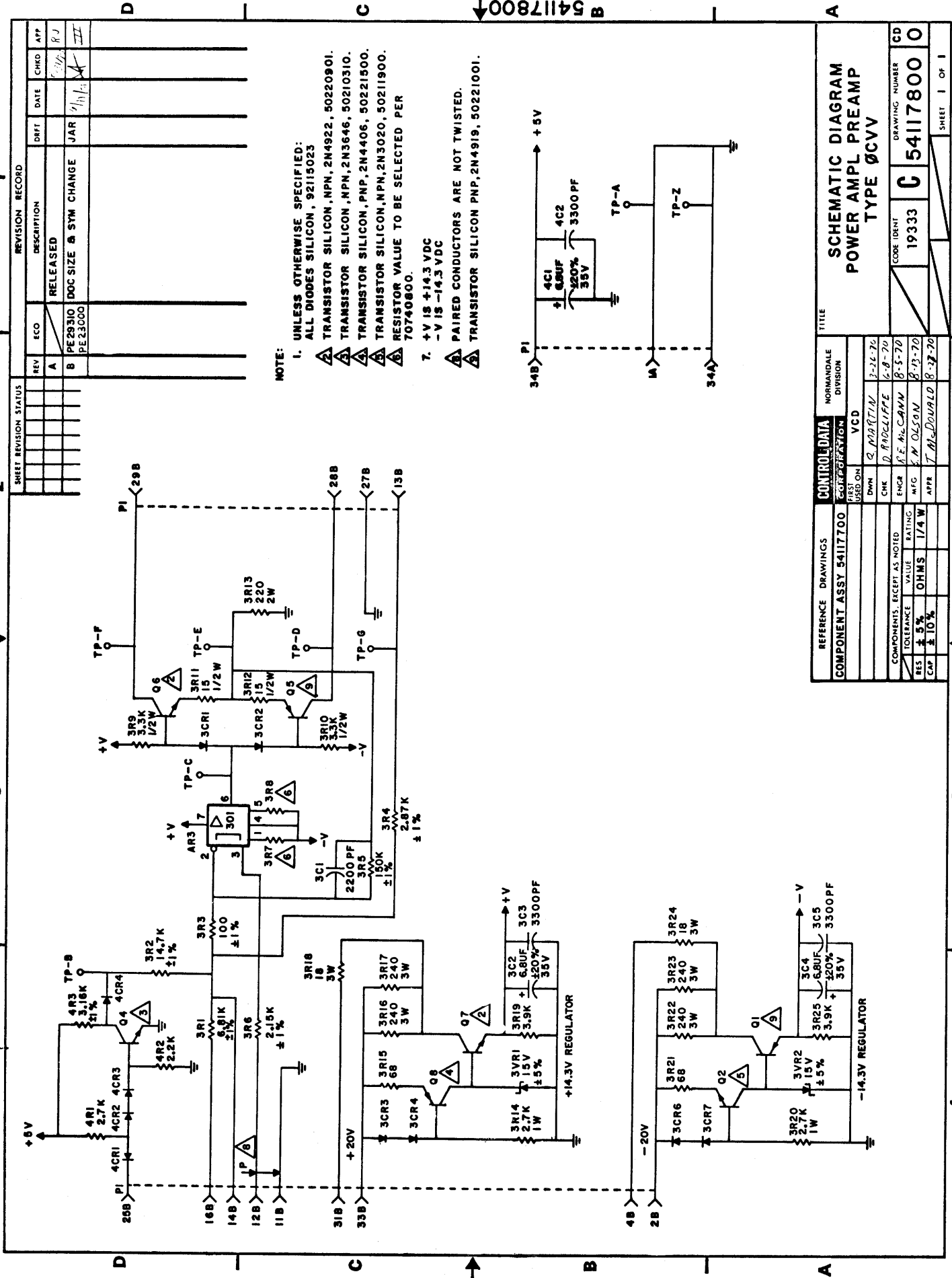

NOTE:

- UNLESS OTHERWISE SPECIFIED:
ALL DIODES SILICON, 92115023
- TRANSISTOR SILICON, PNP, 2N4922, 50220901.
- TRANSISTOR SILICON, PNP, 2N3646, 50210310.
- TRANSISTOR SILICON, PNP, 2N4406, 50221500.
- TRANSISTOR SILICON, PNP, 2N3020, 50211900.
- RESISTOR VALUE TO BE SELECTED PER 70740800.
- +V IS +14.3 VDC
-V IS -14.3 VDC
- PAIRED CONDUCTORS ARE NOT TWISTED.
- TRANSISTOR SILICON PNP, 2N4919, 50221001.

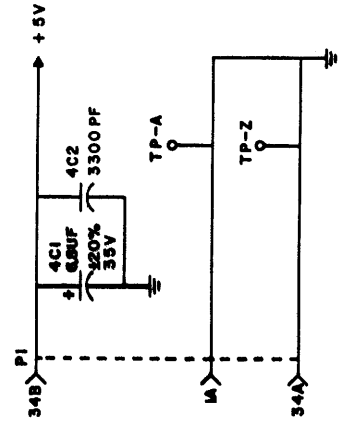

SHEET REVISION STATUS		REVISION RECORD		TITLE	
REV	ECO	DESCRIPTION	DRFT	DATE	CHKD APP
A		RELEASED			
B		DOC SIZE & SYM CHANGE	JAR	1/11/70	RJ
		PE23030			
		PE23000			

REFERENCE DRAWINGS	CONTROL DATA	NORMANDEALE DIVISION
COMPONENT ASSY 5411700	EXPERIMENTATION	VCD
FIRST USED ON:	DWN	Q. MARTIN 3-26-70
	CHK	D. RADCLIFFE 6-8-70
	ENGR	R. E. McCAW 8-5-70
	MFG	E. M. OLSON 8-13-70
	APPR	T. McDONALD 8-17-70

COMPONENTS, EXCEPT AS NOTED	VALUE	RATING
RES	± 5%	OHMS 1/4 W
CAP	± 10%	

SCHEMATIC DIAGRAM		DRAWING NUMBER	
POWER AMPL PREAMP		19333	C 54117800
TYPE 0CVV			

CODE 10RNT	19333	DRAWING NUMBER	54117800	SHEET 1 OF 1
------------	-------	----------------	----------	--------------

54117800

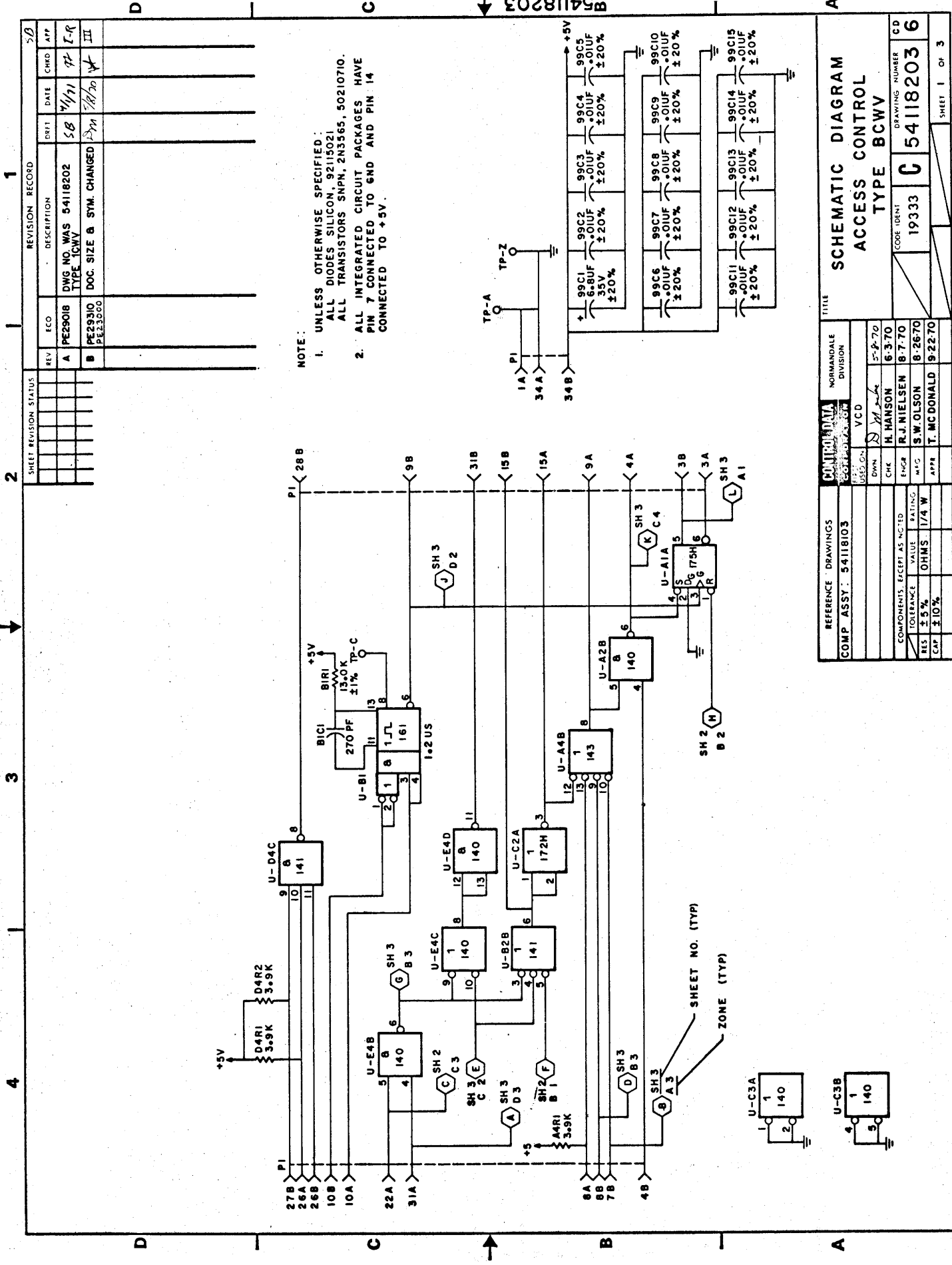

NOTE:
 1. UNLESS OTHERWISE SPECIFIED:
 ALL DIODES SILICON, 92115021
 ALL TRANSISTORS SNPN, 2N3565, 50210710.
 2. ALL INTEGRATED CIRCUIT PACKAGES HAVE
 PIN 7 CONNECTED TO GND AND PIN 14
 CONNECTED TO +5V.

REV	ECO	DESCRIPTION	DATE	CHKD	APP
A	PE29018	DWG NO. WAS 54118202 TYPE ICWV	7/1/70	SB	I-R
B	PE29310 PE29300	DOC. SIZE & SYM. CHANGED	7/20/70		III

REV	ECO	DESCRIPTION	DATE	CHKD	APP
A	PE29018	DWG NO. WAS 54118202 TYPE ICWV	7/1/70	SB	I-R
B	PE29310 PE29300	DOC. SIZE & SYM. CHANGED	7/20/70		III

REFERENCE	DRAWINGS	COMPONENT DATA	NORMAN DALE	DIVISION
COMP ASSY:	54118103	54118203	VCD	
DESIGN	H. HANSON	5-8-70		
ENGR	R.J. NIELSEN	6-3-70		
INSP	S.W. OLSON	8-7-70		
APPR	T. McDONALD	9-22-70		

COMPONENTS, EXCEPT AS NOTED	VALUE	TOLERANCE	RATING
RES	±5%	OHMS	1/4 W
CAP	±10%		

TITLE
 SCHEMATIC DIAGRAM
 ACCESS CONTROL
 TYPE BCWV

19333 CODE IDENT
 DRAWING NUMBER
 54118203
 SHEET 1 OF 3

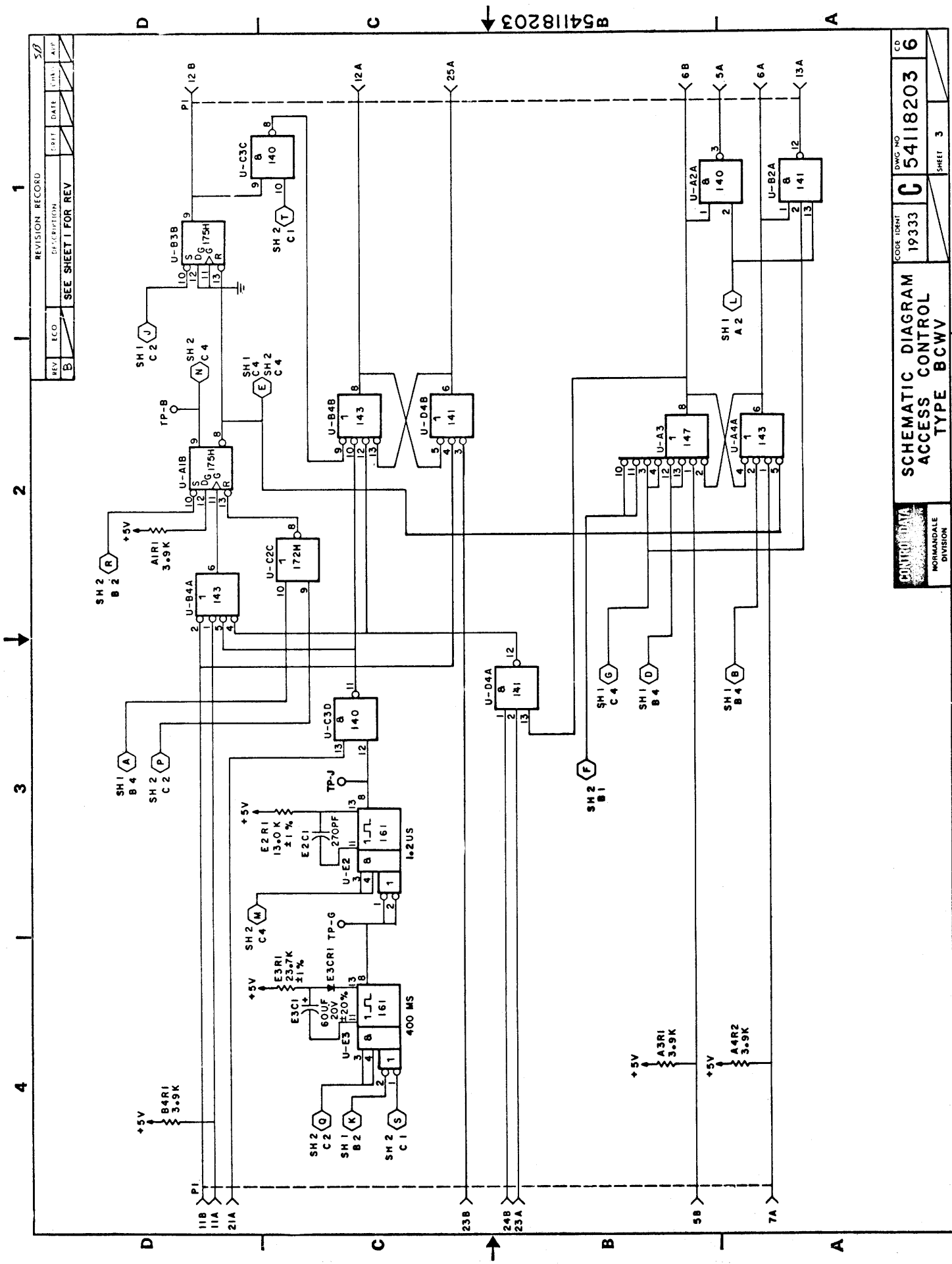

REVISION RECORD			
REV	ECO	DESCRIPTION	DATE
B		SEE SHEET 1 FOR REV	

CD	DWG NO	54118203	6
CODE IDENT	19333	C	
SCHEMATIC DIAGRAM		ACCESS CONTROL	
TYPE BCWV		SHEET 3	

B54118203

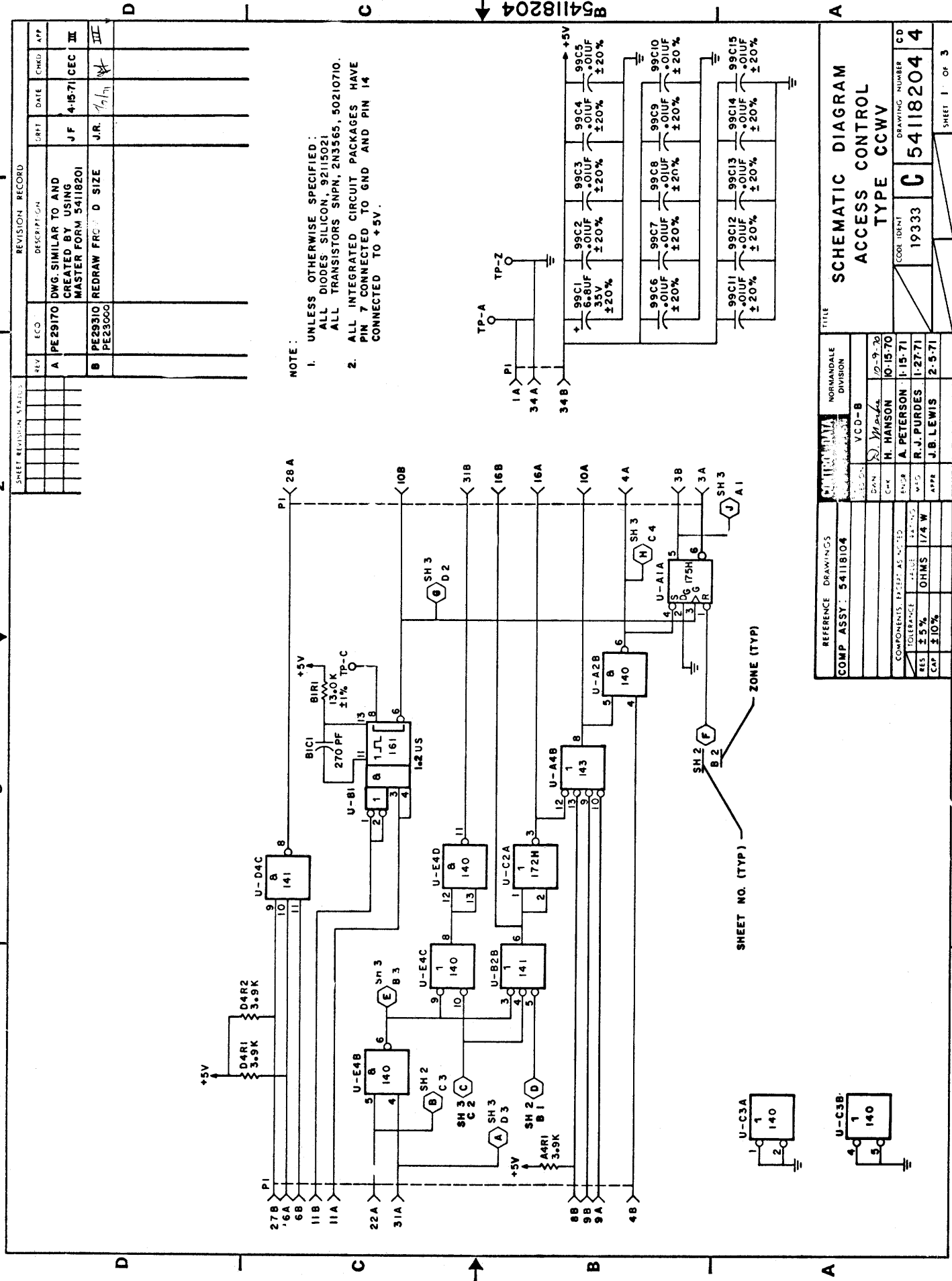

NOTE:
 1. UNLESS OTHERWISE SPECIFIED:
 ALL DIODES: SILICON, 92115021
 ALL TRANSISTORS: SNPN, 2N3565, 50210710.
 2. ALL INTEGRATED CIRCUIT PACKAGES HAVE
 PIN 7 CONNECTED TO GND AND PIN 14
 CONNECTED TO +5V.

REV	ECO	DESCRIPTION	DATE	CHKD	APP
A	PE29170	DWG. SIMILAR TO AND CREATED BY USING MASTER FORM 54118201	4-15-71	J.F.	CEC III
B	PE29310 PE23000	REDRAW FROM D SIZE	7/6/71	J.R.	III

REFERENCE DRAWINGS		NORMANDALE DIVISION	
COMP ASSY	54118104	DESIGN	VCD-B
DATE	10-15-70	CHKD	H. HANSON
DESIGNED BY	A. PETERSON	DATE	10-15-70
DESIGNED BY	R.J. PURDES	DATE	1-27-71
APPR	J.B. LEWIS	DATE	2-5-71

SCHEMATIC DIAGRAM		ACCESS CONTROL	
TYPE		CCW	
COOL IDENT	19333	DRAWING NUMBER	54118204
CD	4	SHEET	1 OF 3

B54118204

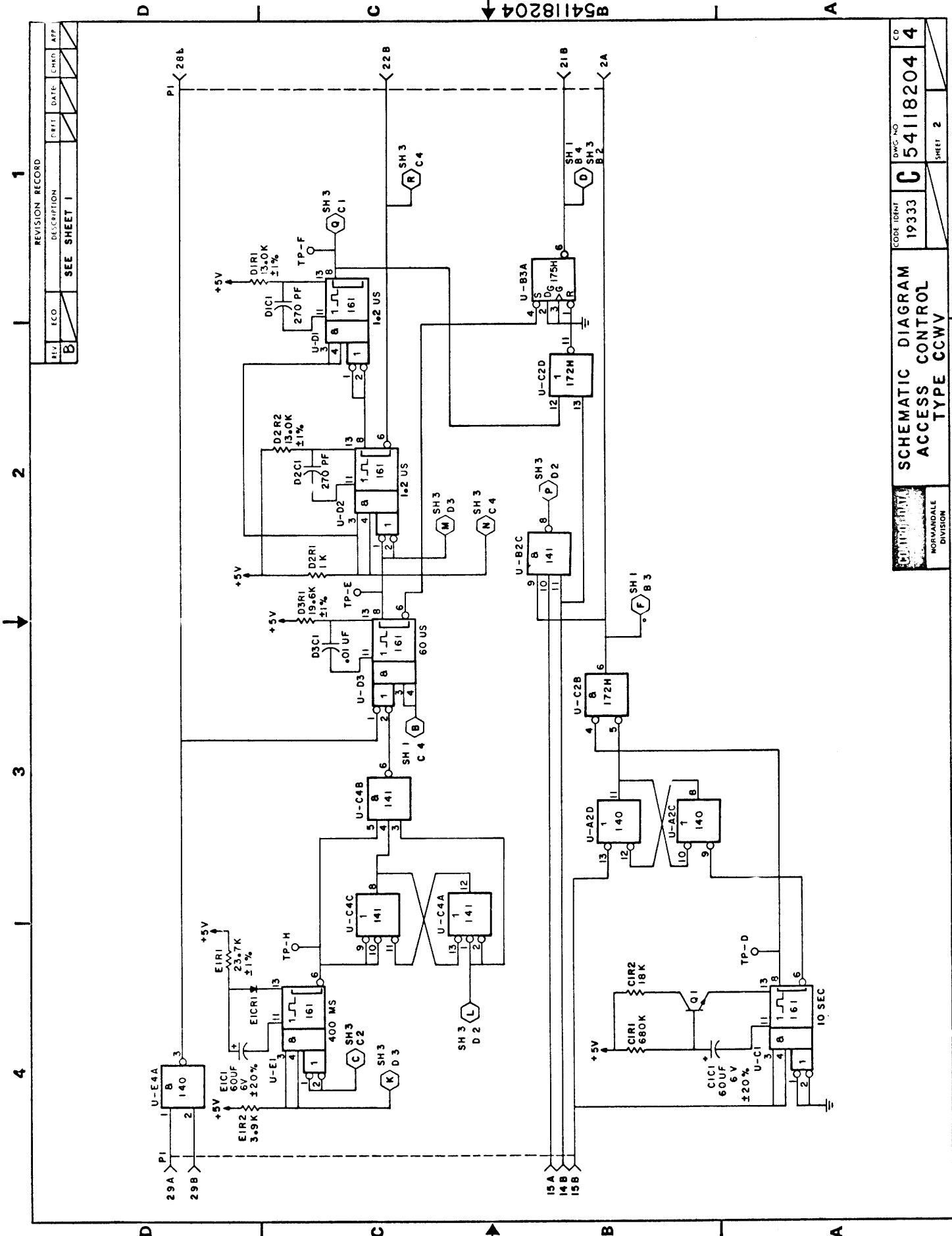

REVISION RECORD

REV	ECO	DESCRIPTION	DATE	CHKD	APP
B		SEE SHEET 1			

SCHEMATIC DIAGRAM
ACCESS CONTROL
TYPE CCWV

19333

DWG NO 54118204

SHEET 2

D B54118204 A

D C B A

1 2 3 4

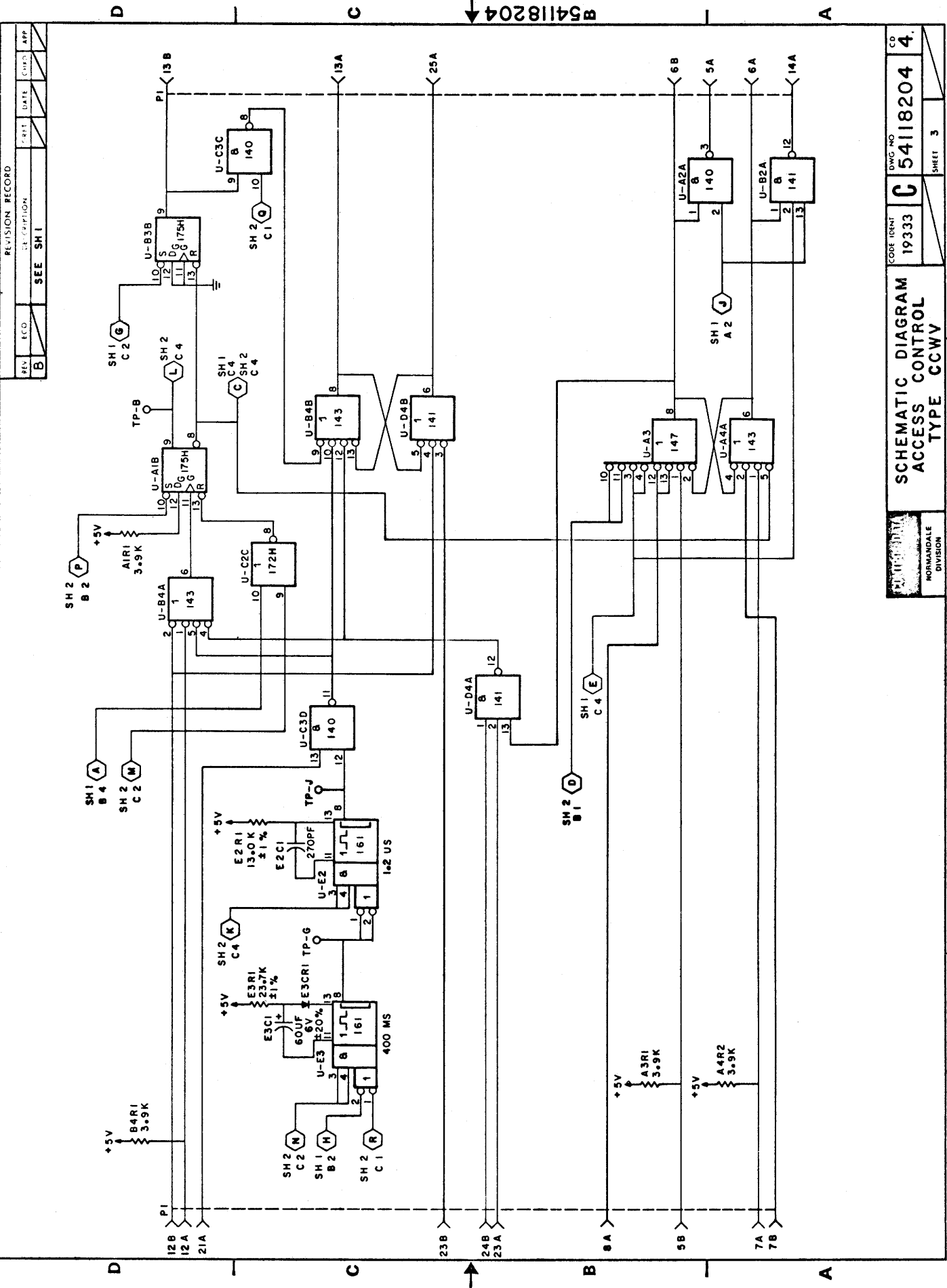

REVISION RECORD			
REV	ECO	DESCRIPTION	DATE
1	B	SEE SH1	

PLANT DIVISION
NORMAN DALE
DIVISION

**SCHEMATIC DIAGRAM
ACCESS CONTROL
TYPE CCW**

CD
DWG NO
C 54118204
1933
SHEET 3

B54118204

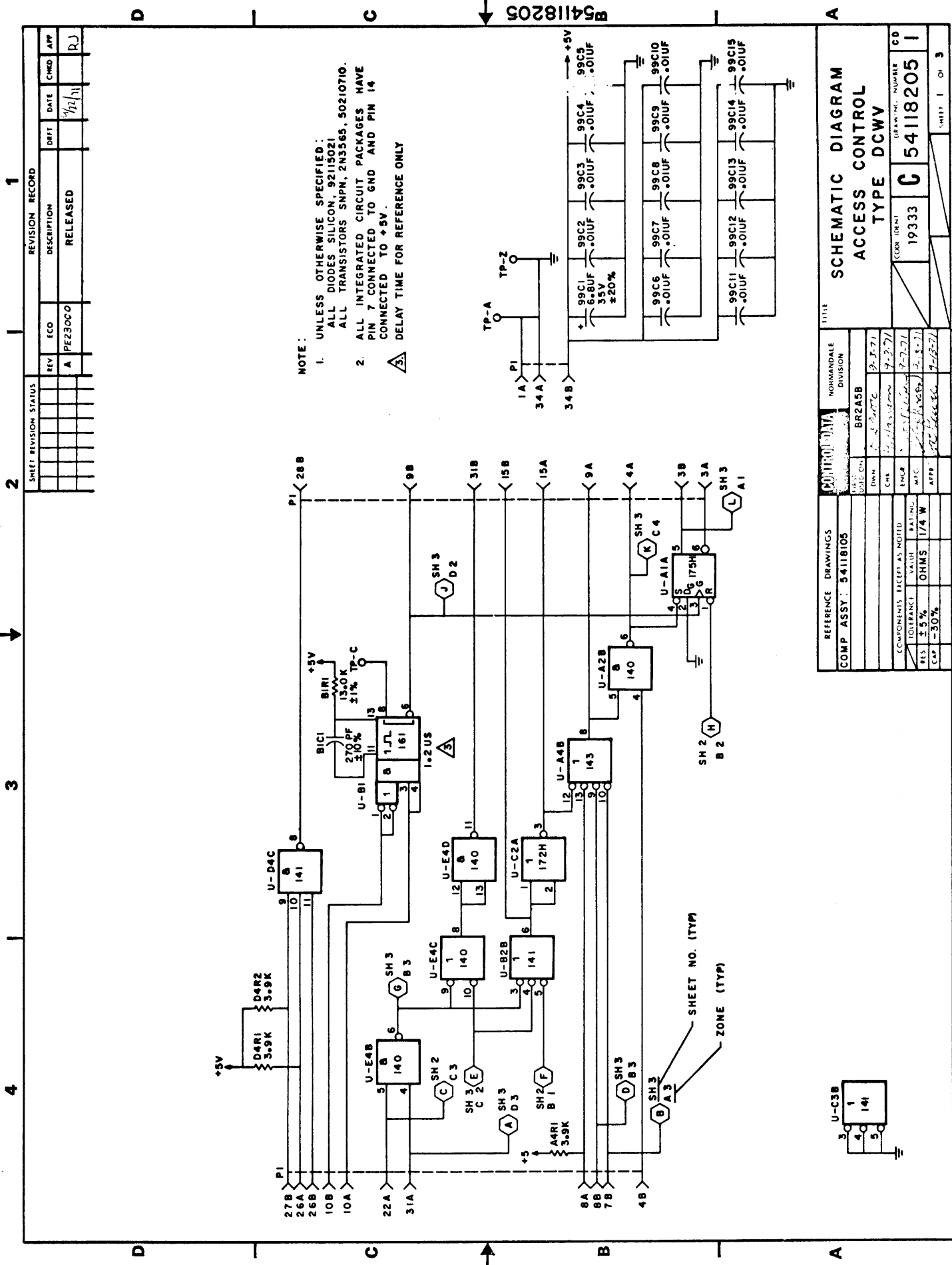

SHEET REVISION STATUS		REVISION RECORD			
REV	ECO	DESCRIPTION	DATE	CHKD	APP
A	FE23000	RELEASED	7/21/71		PJ

REFERENCE DRAWINGS		CONTROL DATA		NORMANVILLE DIVISION	
COMP ASSY: 54118105		DATE CHG	BR2ASB		
COMPONENTS EXCEPT AS NOTED		OWN	3-1-71		
TOLERANCE VALUE		ENGR	7-2-71		
RES ±5%		WFC	7-2-71		
CAP -30%		APPR	7-2-71		
		APPR	7-2-71		

SCHEMATIC DIAGRAM			ACCESS CONTROL		TYPE DCW	
COORDINATE	19333	CD	19333	CD	54118205	I
SHEET 1			OF 3			

54118205

REVISION RECORD			
REV	ECO	DESCRIPTION	DATE
A		SEE SHEET 1 FOR REV	

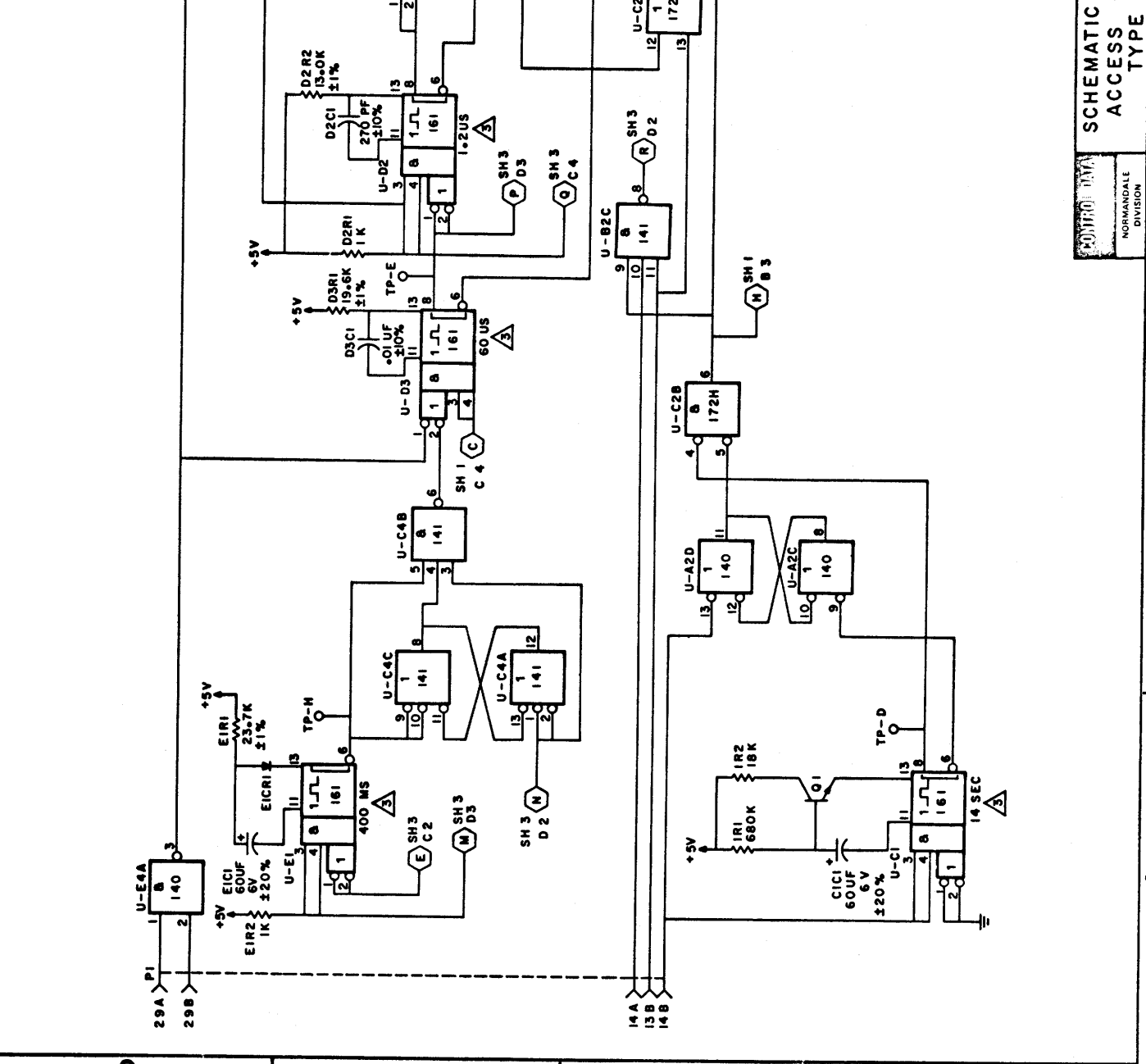

70616800 D

7-140.1

CONTROL DATA	NORMANDALE DIVISION	COM. INVT.	19333	BWG. NO.	C 54118205	CD	1
		SCHEMATIC DIAGRAM ACCESS CONTROL TYPE DCWV		SHEET 2	1		

B54118205

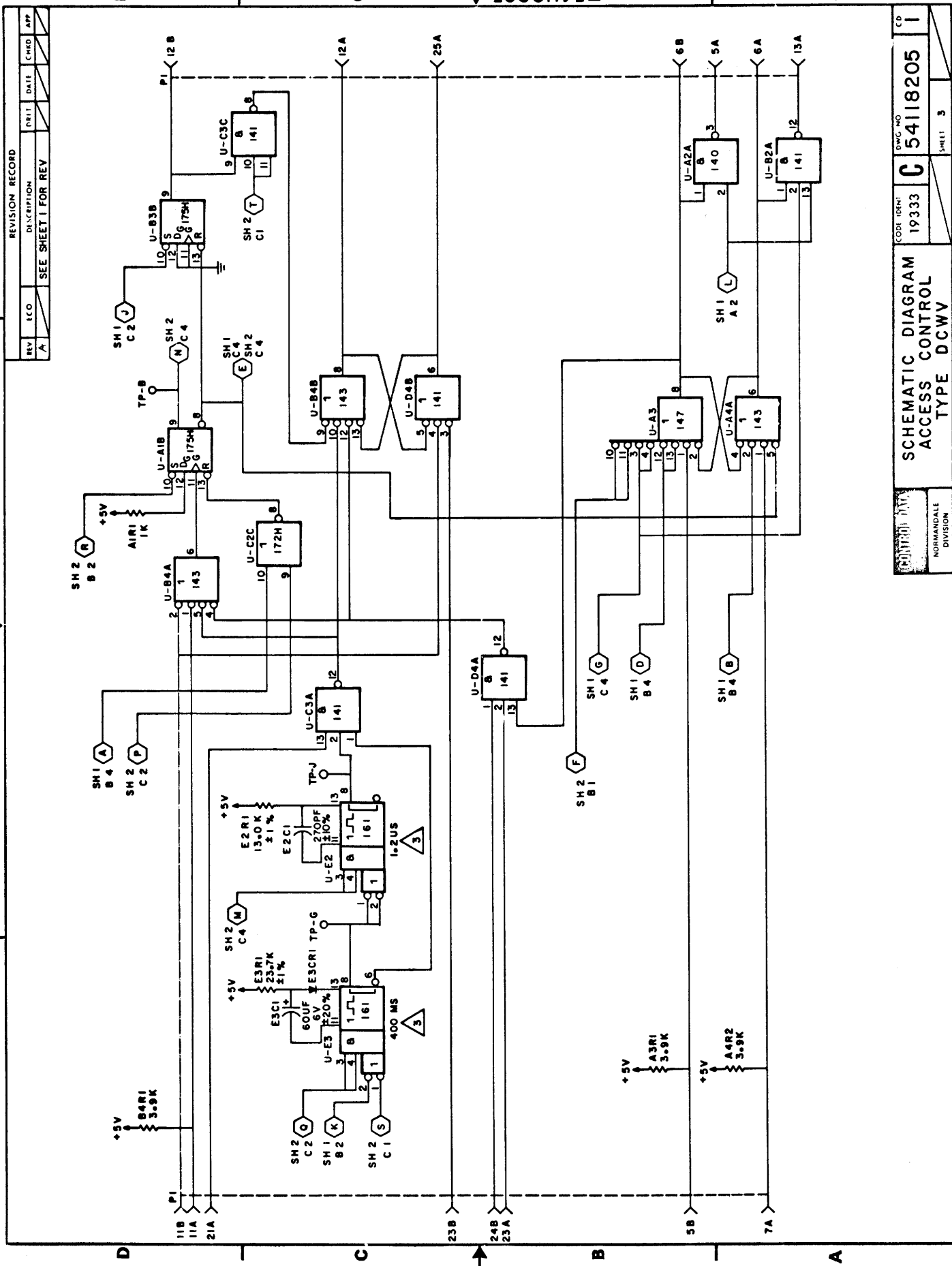

B54118205

REVISION RECORD					
REV	ECO	DESCRIPTION	DATE	CHKD	APP
A		SEE SHEET 1 FOR REV			

CORP IDENI		DWG NO	CD
19333		C	54118205
NORMANDEALE DIVISION		SHEET 3	
SCHEMATIC DIAGRAM ACCESS CONTROL TYPE DCWV			

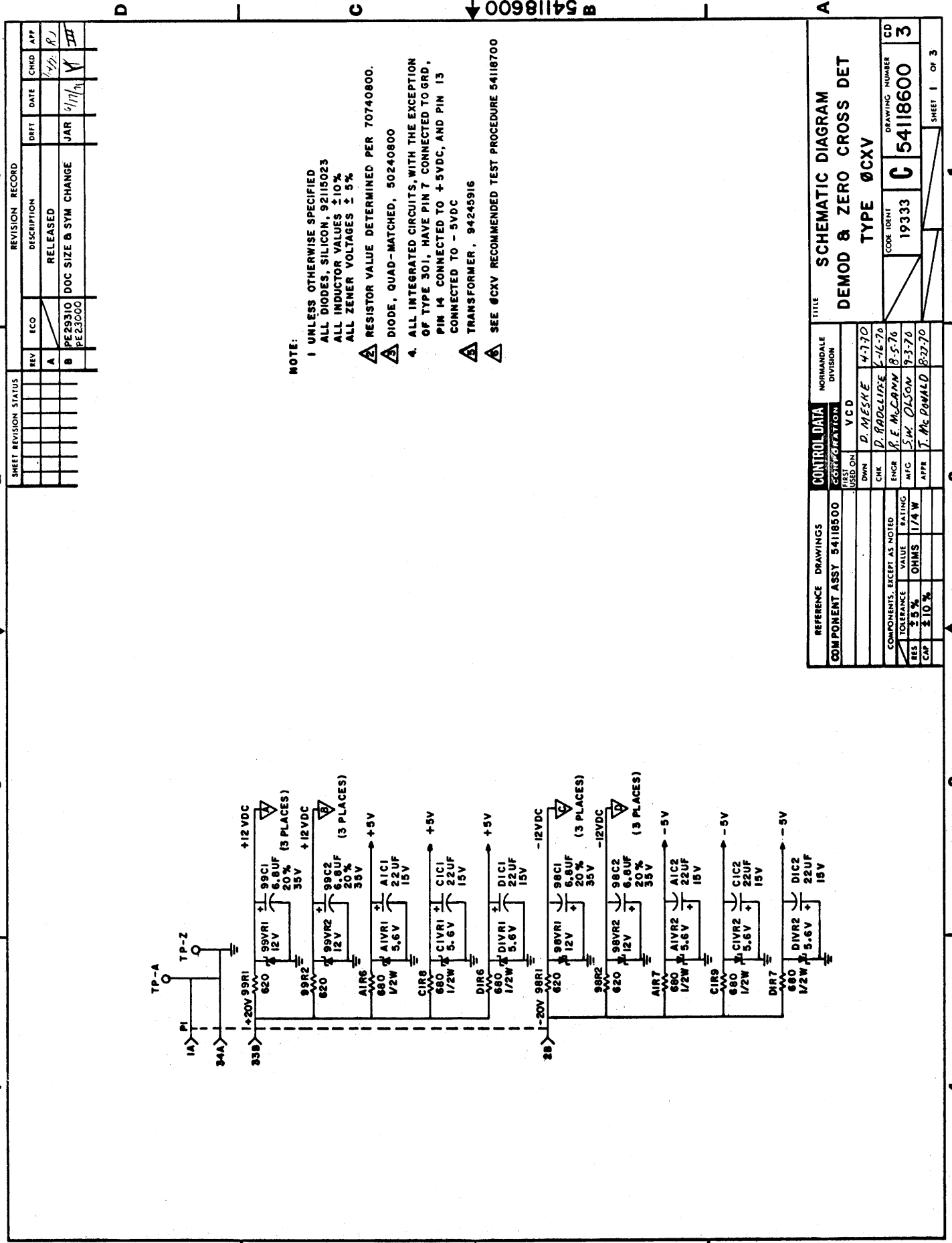

NOTE:

- 1 UNLESS OTHERWISE SPECIFIED ALL DIODES, SILICON, 92115023
- ALL INDUCTOR VALUES $\pm 10\%$
- ALL ZENER VOLTAGES $\pm 5\%$
- 2 RESISTOR VALUE DETERMINED PER 70740800.
- 3 DIODE, QUAD-MATCHED, 50240800
- 4 ALL INTEGRATED CIRCUITS, WITH THE EXCEPTION OF TYPE 301, HAVE PIN 7 CONNECTED TO GRD, PIN 14 CONNECTED TO +5VDC, AND PIN 13 CONNECTED TO -5VDC
- 5 TRANSFORMER, 94245916
- 6 SEE 0CXV RECOMMENDED TEST PROCEDURE 54118700

SHEET REVISION STATUS			REVISION RECORD			
REV	ECO	DESCRIPTION	DRFT	DATE	CHKD	APP
A		RELEASED			JAR	
B	PE29310 PE23000	DOC SIZE & SYM CHANGE		6/11/71		

REFERENCE DRAWINGS		CONTROL DATA		TITLE	
COMPONENT ASSY 54118500		CORRECTION		NORMAN DALE	
		FIRST USED ON		DIVISION	
		DWN		VCD	
		CHK		D. MESKE 4-7-70	
		ENGR		D. RADCLIFFE 4-16-70	
		MFC		R. E. McCANN 8-5-70	
		APPR		S. W. OLSON 9-3-70	
				T. Mc DONALD 8-27-70	
COMPONENTS EXCEPT AS NOTED		TOLERANCE VALUE		DRAWING NUMBER	
RES $\pm 5\%$		OHMS 1/4 W		19333	
CAP $\pm 10\%$				C 54118600	
				DRAWING NUMBER	
				CD 3	
				SHEET 1 OF 3	

54118600



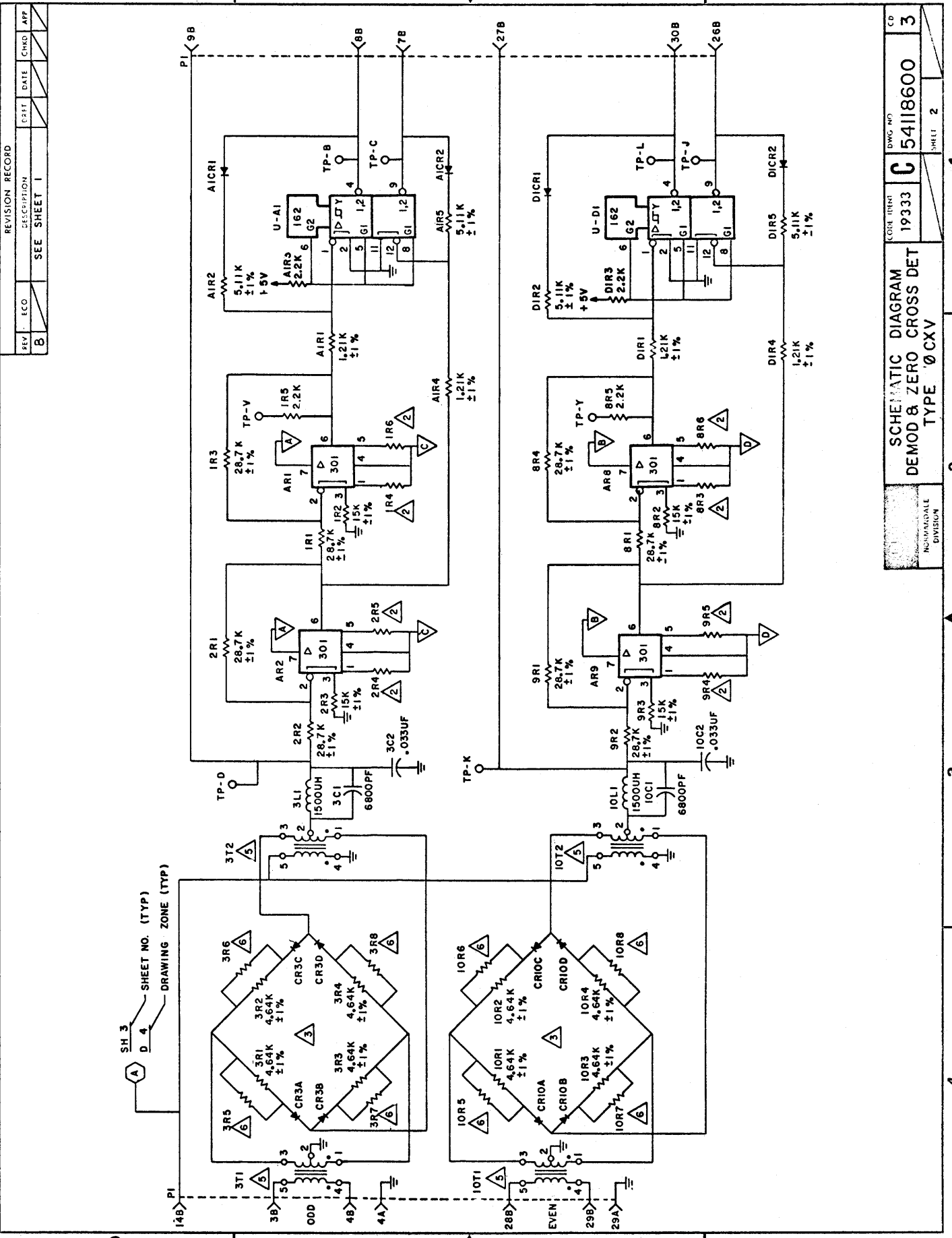

REV	ECO	DESCRIPTION	DATE	CHKD	APP
B		SEE SHEET 1			

INSURGABLE DIVISION	CD	DWG NO	CD
		54118600	3
	CORE ITEM	19333	
	SCHEMATIC DIAGRAM		
	DEMOD & ZERO CROSS DET		
	TYPE ØCXV		
		DRU 2	1

1 2 3 4

4 3 2 1

REVISION RECORD

54118600

REV	ECO	DESCRIPTION	DATE	CHKD	APP
B		SEE SHEET 1			

REVISION RECORD	
1	

CD	3
DWG NO	54118600
CODE IDENT	19333
SCHEMATIC DIAGRAM	
DEMOM 8 ZERO CROSS DET	
TYPE ØCXV	
NORMANDALE DIVISION	
SHEET	3

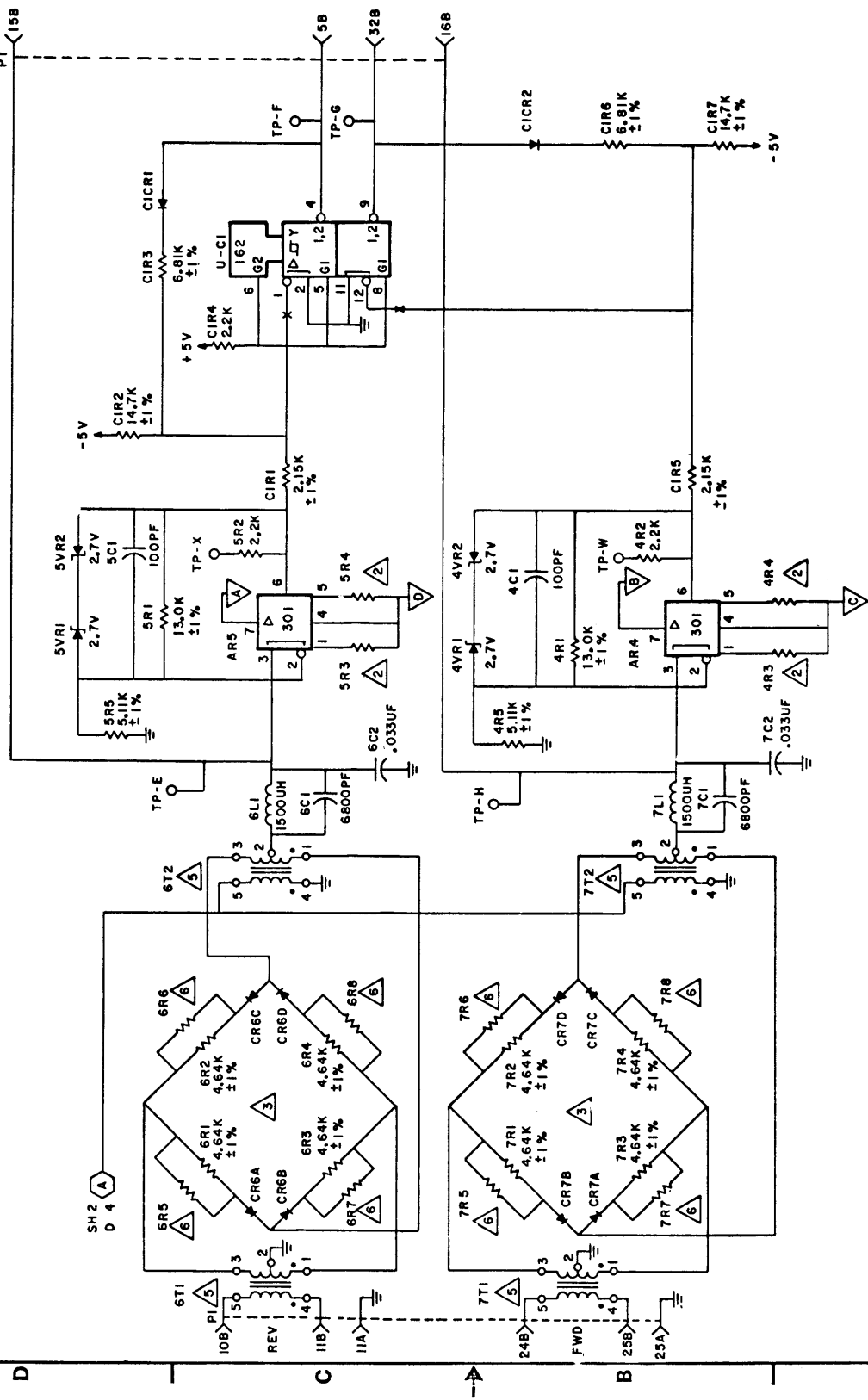

SHEET REVISION STATUS		REVISION RECORD			
REV	ECCO	DESCRIPTION	DATE	CHKD	APP
A		RELEASED			
B		A3R2 WAS 14.7K, A3C1 WAS 470 PF, IOUS WAS 2US, ASSY NO WAS 54118900.	11/17/70	BR	RJ
C		PE 29310 DOC SIZE & SYMBOL PE23000 CHANGE.	11/17/70	JAR	III

NOTE:
1. ALL INTEGRATED CIRCUIT PACKAGES HAVE PIN 7 CONNECTED TO GRD AND PIN 14 CONNECTED TO +5V

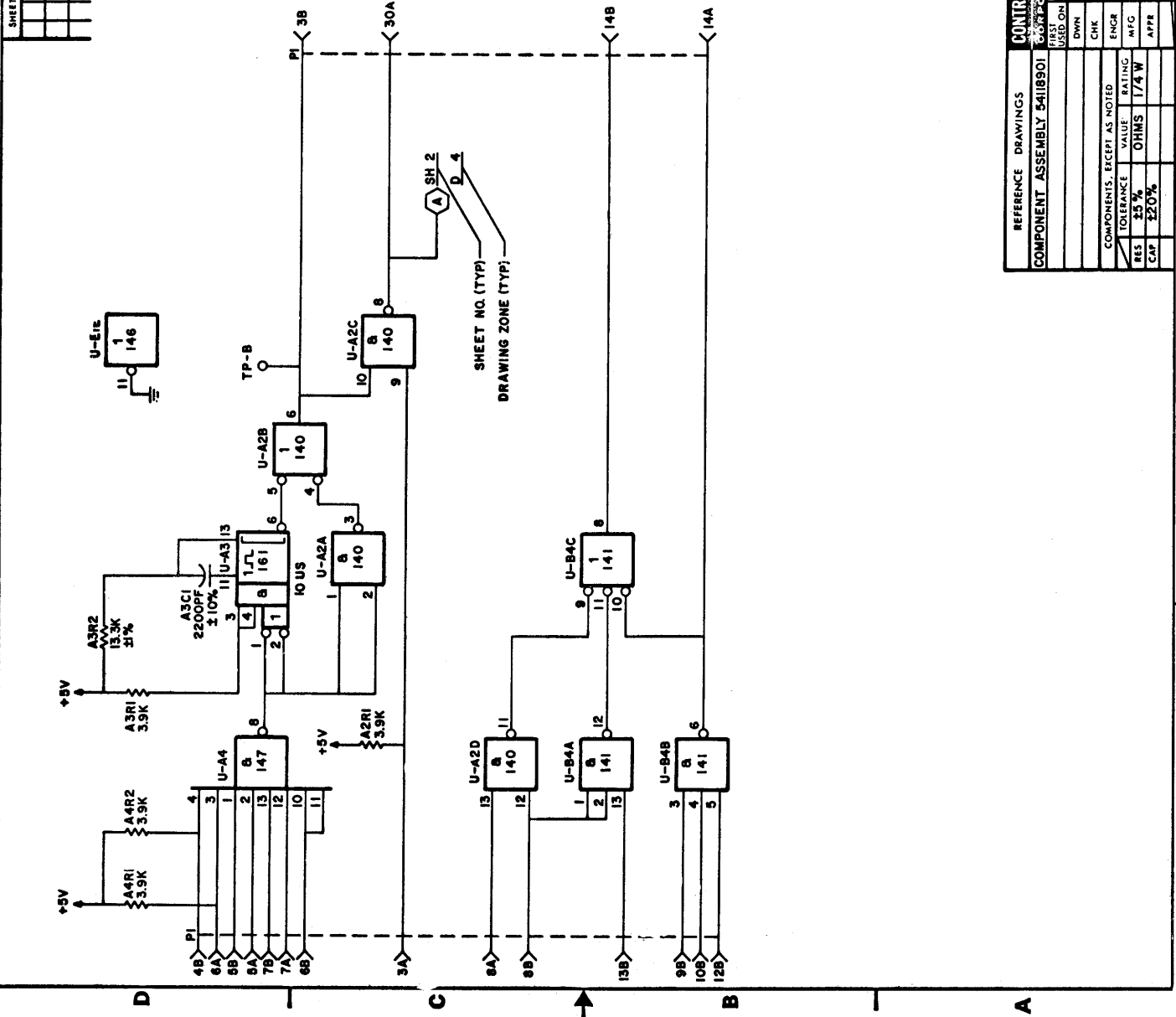

REFERENCE DRAWINGS		CONTROL DATA		NORMANDALE DIVISION	
COMPONENT	ASSEMBLY	DATE	REV	USED ON	VCD
	54118901	6/27/70	1		
CHK	J. E. MATTON	4-18-70			
ENGR	D. RADCLIFFE	5-26-70			
APPR	R. J. NIELSEN	7-27-70			
	S. W. OLSON	8-13-70			
	T. MC DONALD	8-27-70			

SCHEMATIC DIAGRAM		DRAWING NUMBER	
HEAD DECODER		54119000	
TYPE 0CYV		19333	

CD	5
SHEET 1 OF 2	

B 54119000

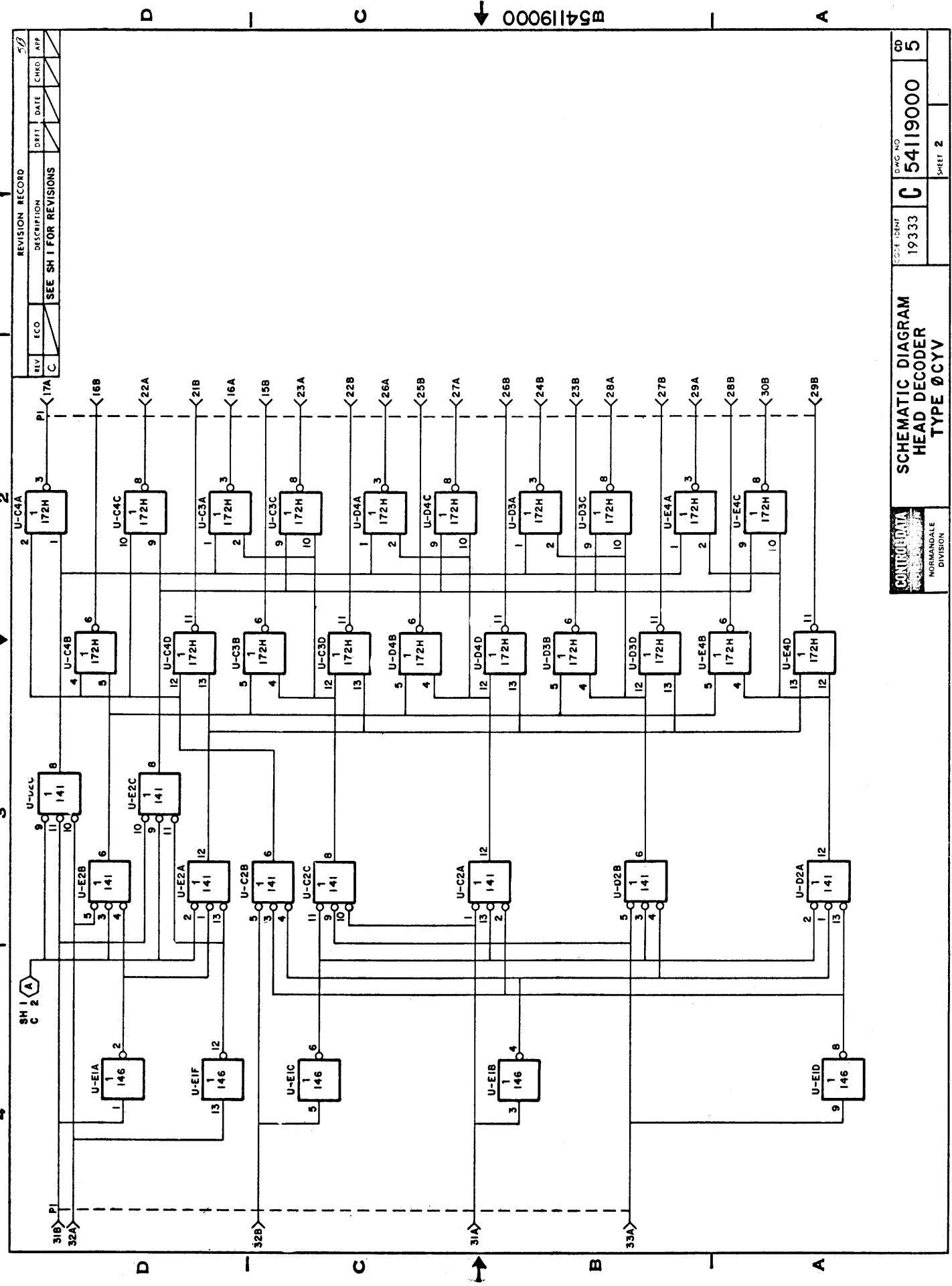

REVISION RECORD			
REV	ECO	DESCRIPTION	DATE
1	C	SEE SH 1 FOR REVISIONS	

SCHEMATIC DIAGRAM		DWG NO	5
HEAD DECODER		ECO IDENT	C 54119000
TYPE ØCYV		SHEET 2	
CONTRON DATA		NORMANVILLE DIVISION	

SHEET REVISION STATUS		REVISION RECORD		
REV	ECO	DESCRIPTION	DRFT	DATE
A		RELEASED		7/4/70
B		DOC SIZE B SYM CHANGE	JR	7/1/71
PE 29310				
FE 25500				

NOTE:
 1. UNLESS OTHERWISE SPECIFIED:
 ALL TRANSISTORS, SILICON, PNP, 2N3638, 50210610.
 ALL DIODES, SILICON, 92115021.
 ALL ZENER DIODE VOLTAGES $\pm 5\%$.
 2. TRANSISTOR, SILICON, NPN, 2N3569, 50210811.
 3. DIODE, GERMANIUM, 11801200.
 4. RESISTOR VALUE TO BE SELECTED PER 70740800.

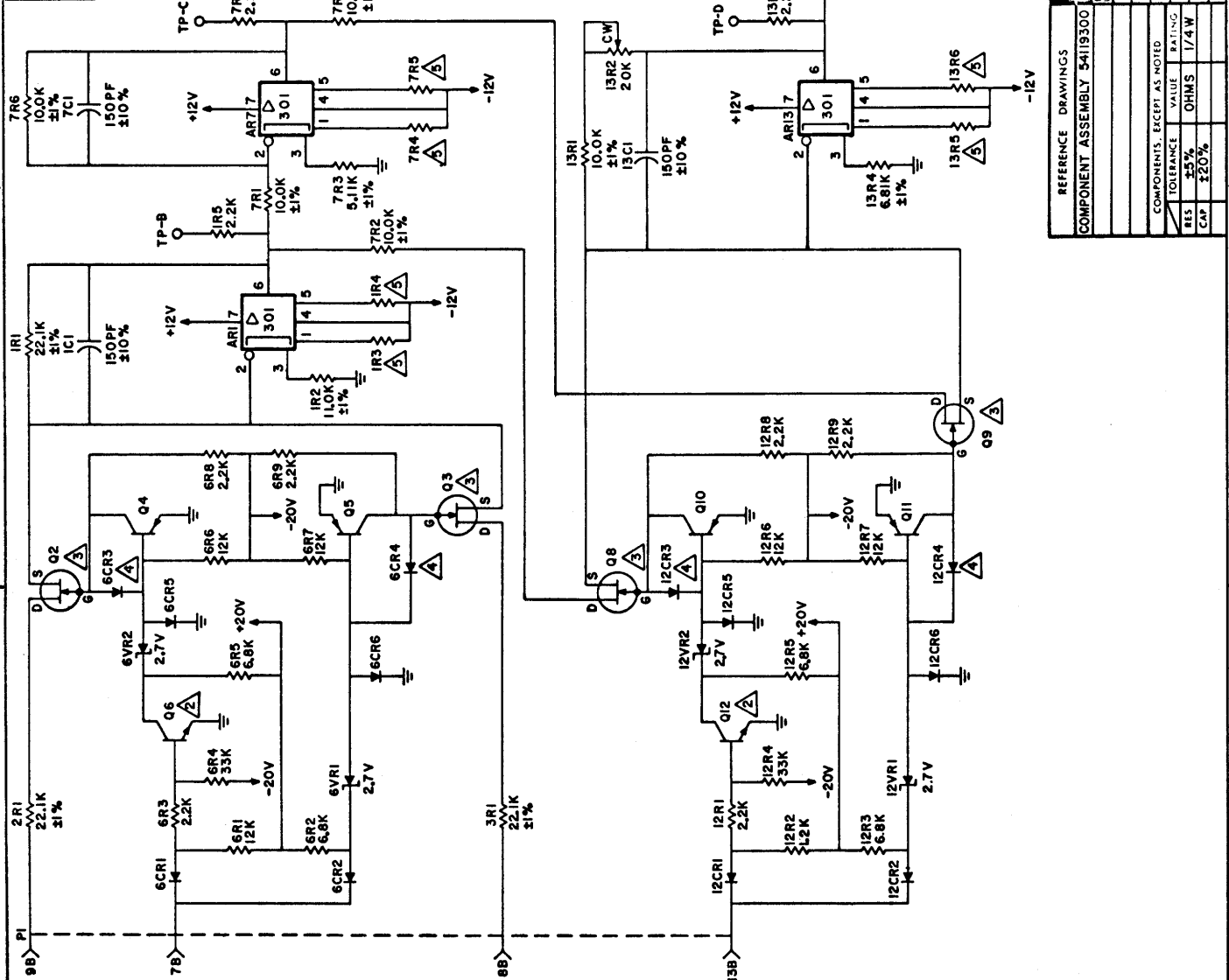

REFERENCE DRAWINGS		NORMAN DALE DIVISION	
COMPONENT ASSEMBLY	54119300	VCD	
REST USED ON		DWN	
ENGR		CHK	
MFG		APPR	
COMPONENTS, EXCEPT AS NOTED			
TOLERANCE	VALUE	RATING	
RES	$\pm 5\%$	OHMS	1/4W
CAP	$\pm 20\%$		

TITLE		DRAWING NUMBER	
SCHEMATIC DIAGRAM		19333	C
ODD-EVEN-SLOPE, ANALOG SWITCH		54119400	
TYPE 0CZC		7	
SHEET 1 OF 1			

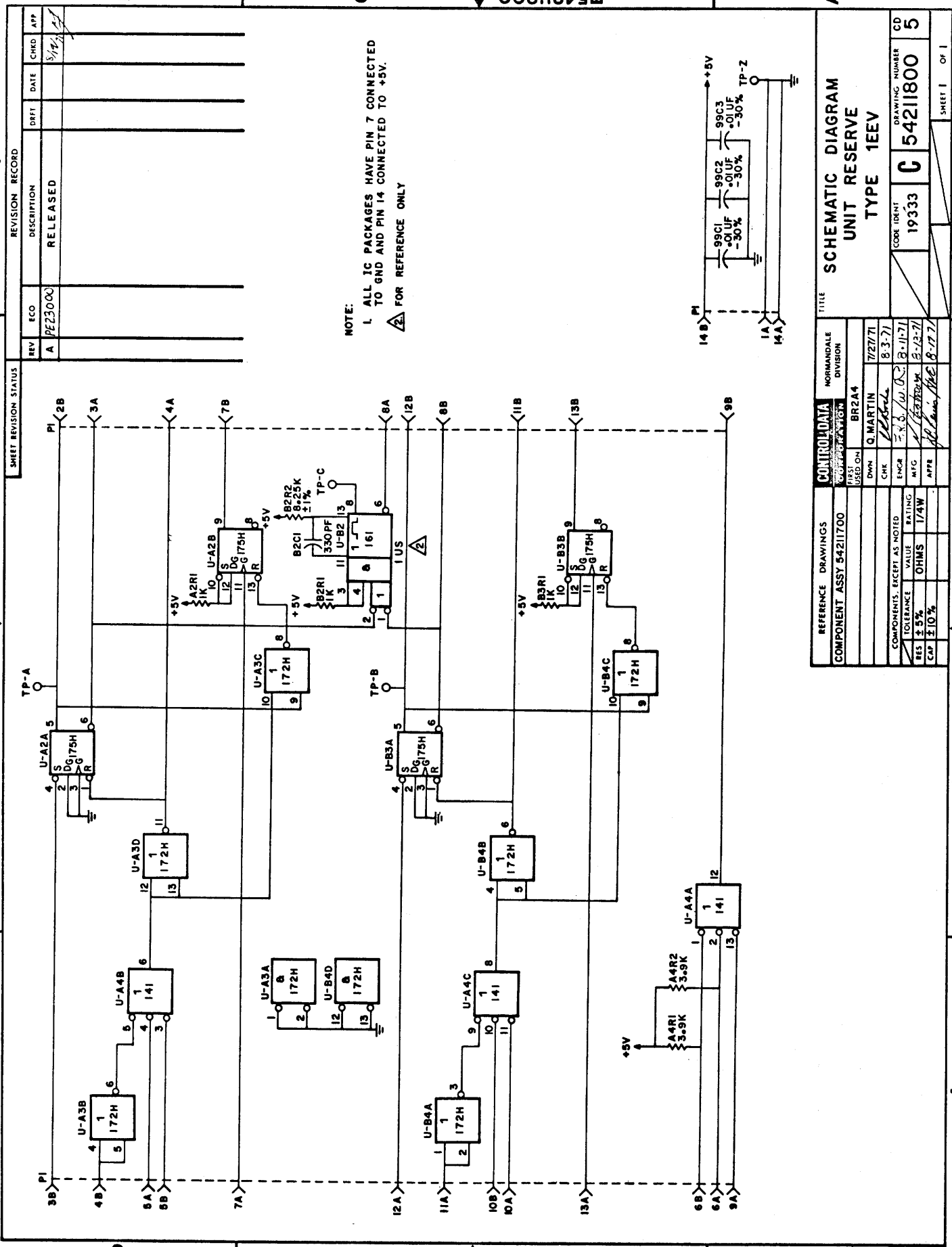

NOTE:
 1. ALL IC PACKAGES HAVE PIN 7 CONNECTED TO GND AND PIN 14 CONNECTED TO +5V.
 2. FOR REFERENCE ONLY

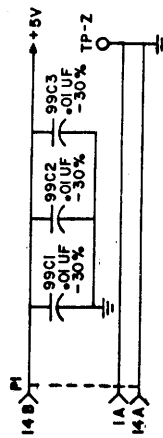

REVISION RECORD		DRFT	DATE	CHKD	APP
REV	ECO				
A	P223000	RELEASED			

SHEET REVISION STATUS		CONTROL DATA		NORMANDALE DIVISION	
1		COMPONENT ASSY 54211700	BR2A4	7/27/71	Q. MARTIN
2				8-3-71	
3				B-11-71	
4				B-13-71	
				B-17-71	

REFERENCE DRAWINGS		TITLE		DRAWING NUMBER	
COMPONENT ASSY 54211700		SCHEMATIC DIAGRAM		19333	
BR2A4		UNIT RESERVE		C 54211800	
CHK Q. MARTIN		TYPE 1EEV		CD 5	
DWN 7/27/71				SHEET 1 OF 1	
ENGR F. J. W. O. S.					
MFG B-11-71					
APPR B. J. W. O. S.					
CAP ±10%					
RES ±5%					
OHMS 1/4W					
RATING					
VALUE					
EXCEPT AS NOTED					

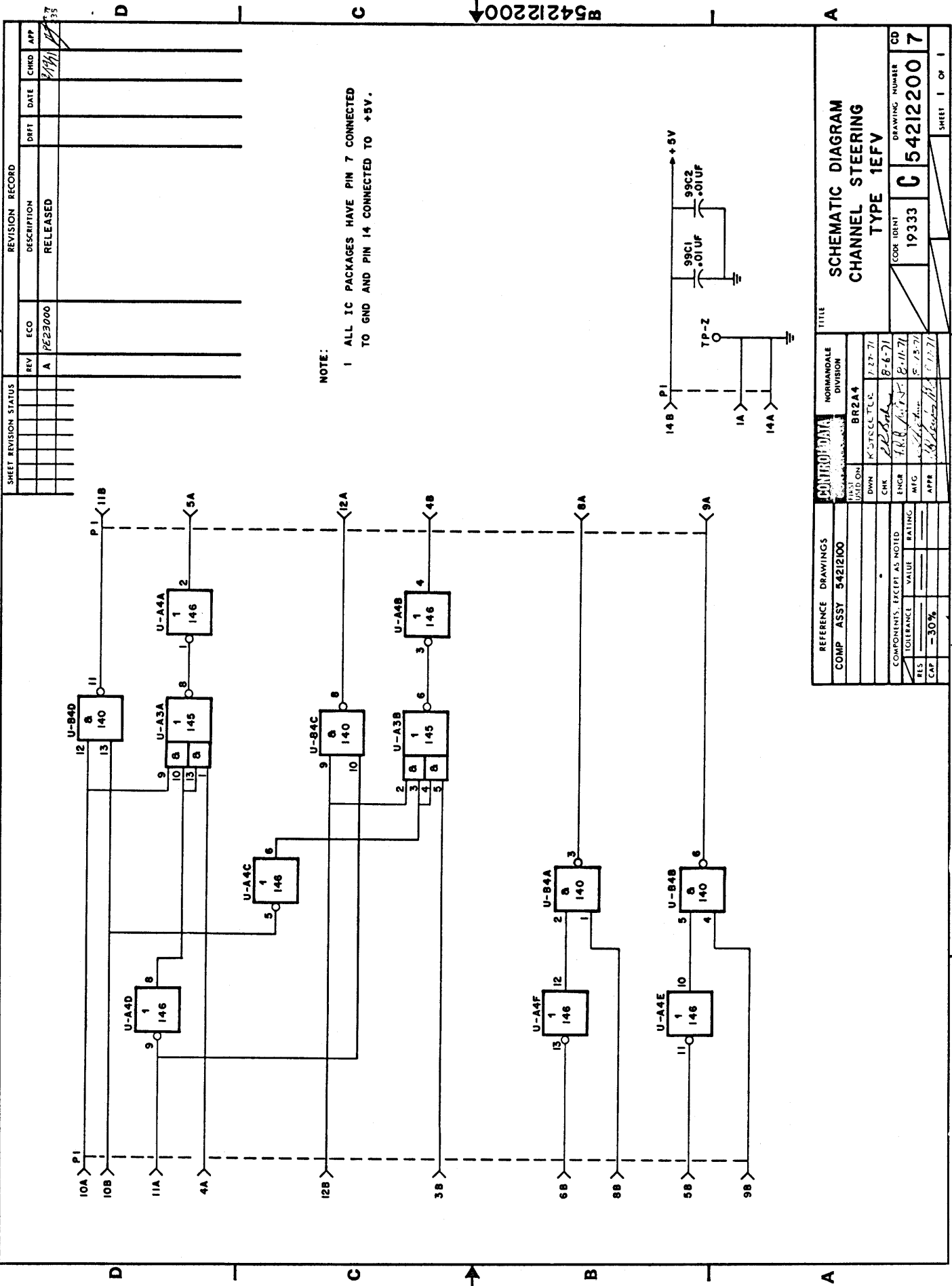

NOTE:
 1 ALL IC PACKAGES HAVE PIN 7 CONNECTED TO GND AND PIN 14 CONNECTED TO +5V.

SHEET REVISION STATUS		REVISION RECORD		
REV	ECO	DESCRIPTION	DATE	CHKD
A	PE23000	RELEASED		

REFERENCE DRAWINGS		CONTROL DATA		NORMANDEALE DIVISION	
COMP	ASSY 5421200	DWN	K STEEL	BR2A4	
COMPONENTS EXCEPT AS NOTED		CHK	RR	8-6-71	
TOLERANCE	VALUE	ENCR	TRR	8-11-71	
RAT		MFG		5-25-71	
CAP	-30%	APPR		1-12-71	

TITLE		DRAWING NUMBER	
SCHEMATIC DIAGRAM CHANNEL STEERING TYPE 1EFV		19333	54212200
		CD	7

B54212200 ↓

VCD 1

↑

SHEET REVISION STATUS		REVISION RECORD			
REV	ECO	DESCRIPTION	DATE	CHKD	APP
A		FEEDBACK DMG SIMILAR TO AND CREATED BY USING MASTER FROM 54218200 TYPE 1EWV	SB 1/1/71		AF

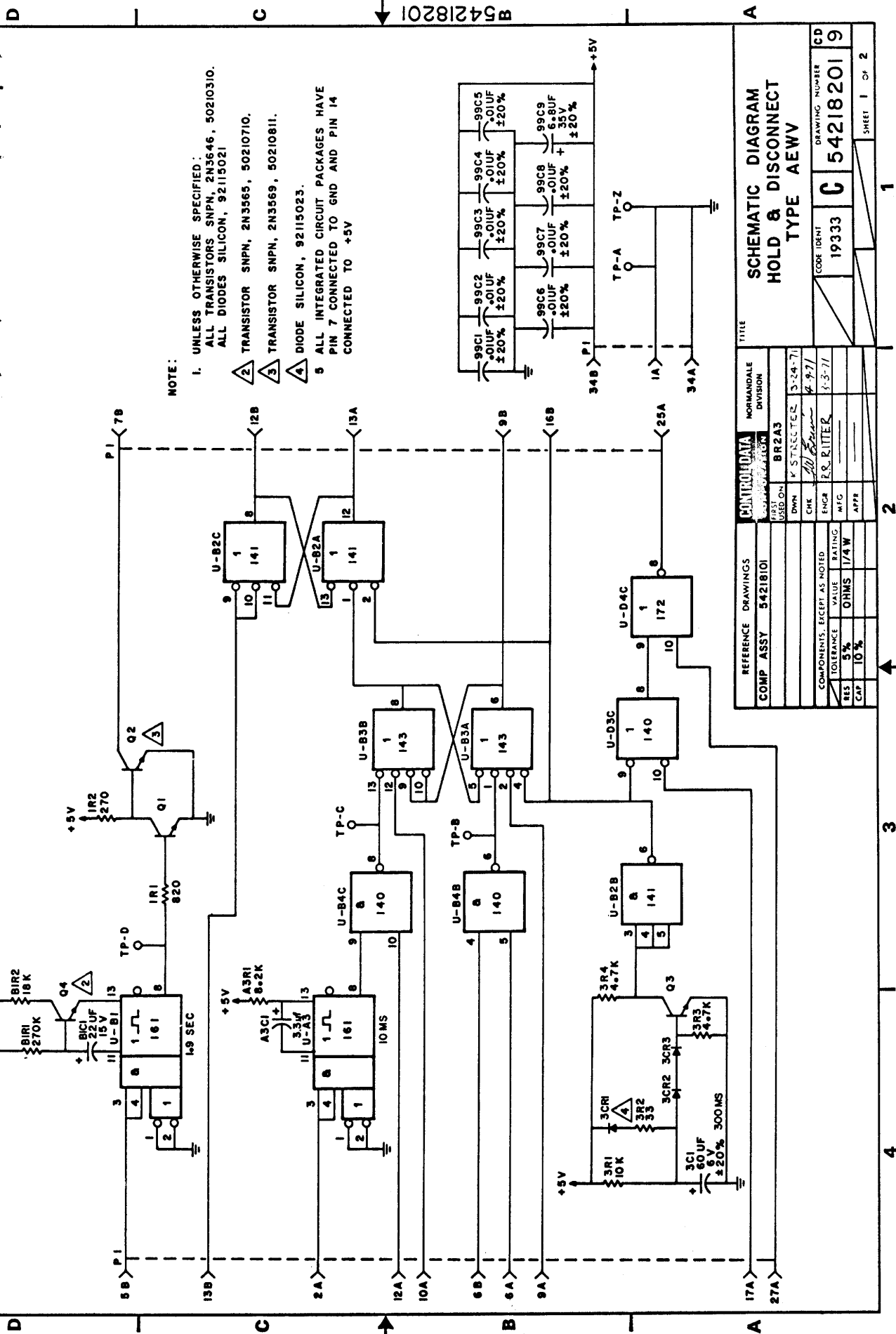

- NOTE:
- UNLESS OTHERWISE SPECIFIED:
ALL TRANSISTORS SNPN, 2N3646, 50210310.
ALL DIODES SILICON, 92115021
 - TRANSISTOR SNPN, 2N3565, 50210710.
 - TRANSISTOR SNPN, 2N3569, 50210811.
 - DIODE SILICON, 92115023.
 - ALL INTEGRATED CIRCUIT PACKAGES HAVE PIN 7 CONNECTED TO GND AND PIN 14 CONNECTED TO +5V

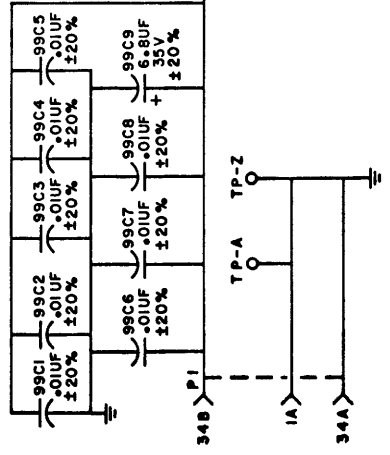

REFERENCE DRAWINGS		NORMANDALE DIVISION	
COMP ASSY	54218101	BR 2A3	
CONTROL DATA		USED ON	
		CHK	V. STREETER 3-24-71
		ENGR	R.S. RITTER 4-9-71
		APPR	
COMPONENTS, EXCEPT AS NOTED			
RES	5%	OHMS	1/4 W
CAP	10%		

SCHEMATIC DIAGRAM		DRAWING NUMBER	
HOLD & DISCONNECT		19333	C 54218201
TYPE AEW			9

REV	ECCO	DESCRIPTION	DATE	CHKD	APP
		SEE SHT 1 FOR REV			

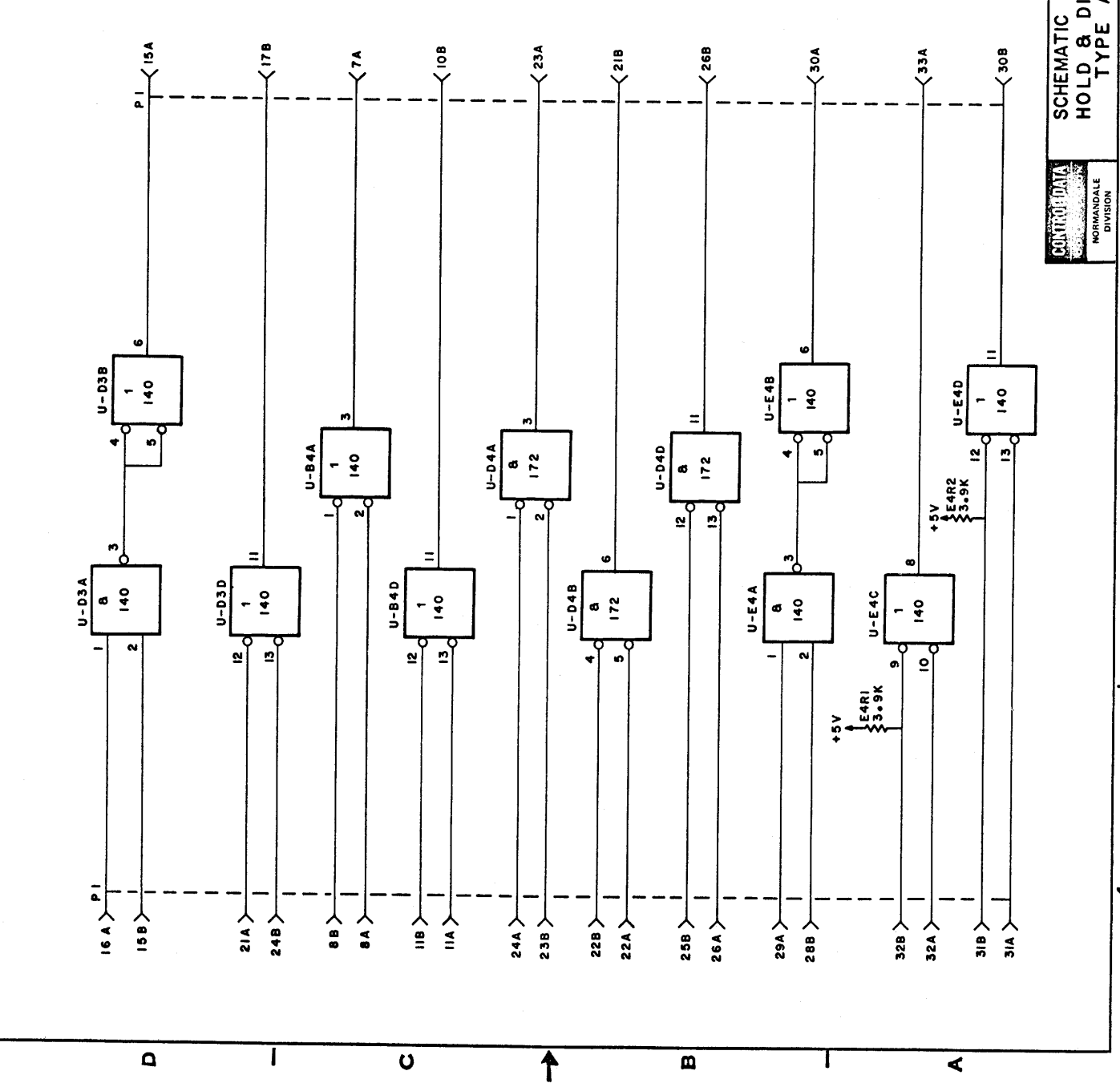

CONTROL DATA	SCHEMATIC DIAGRAM	CD
NORMANDELL DIVISION	HOLD & DISCONNECT	19333
	TYPE AEW	54218201
		DWG NO
		54218201
		SHEET 2 OF 2

B54218201 ↓

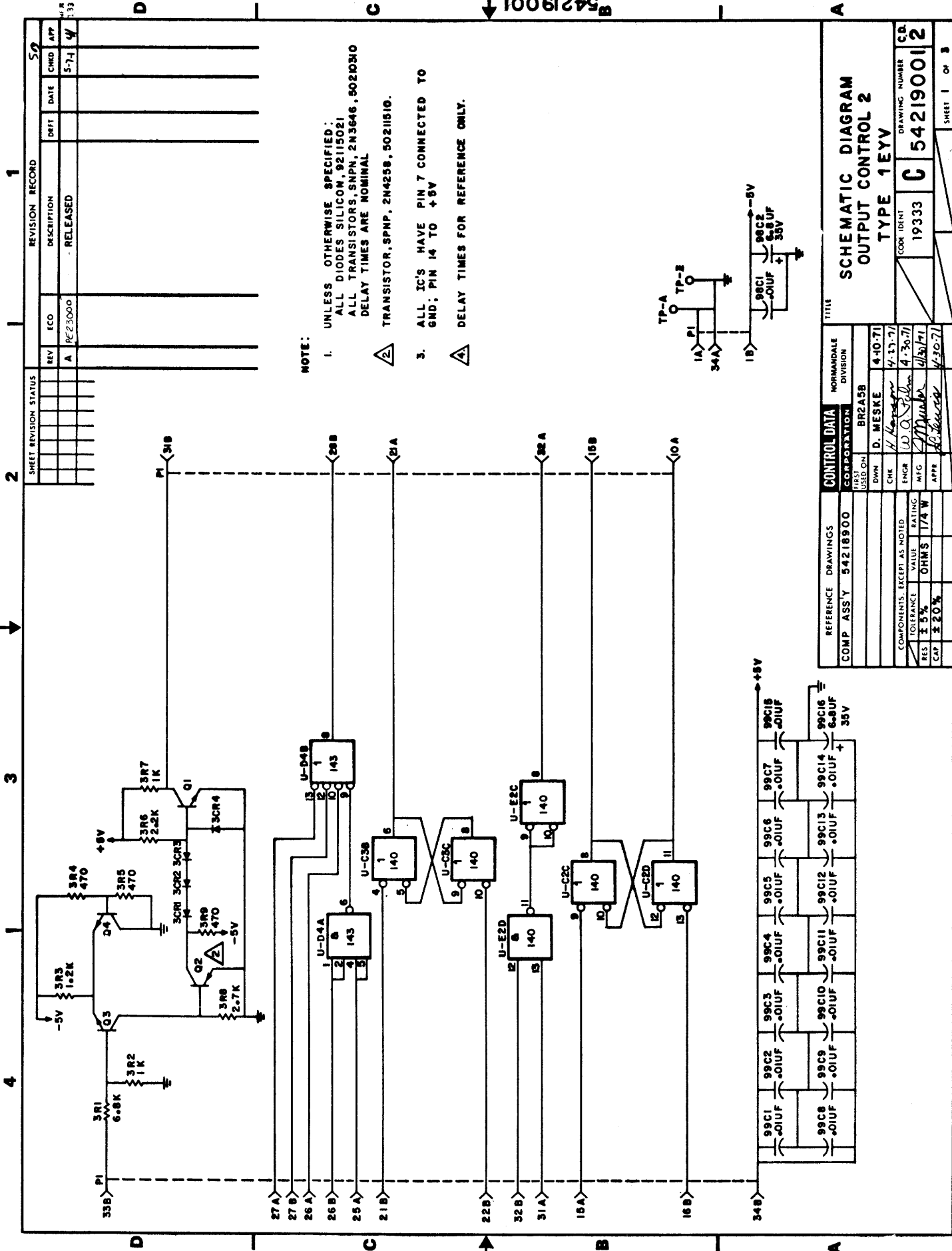

- NOTE:**
- UNLESS OTHERWISE SPECIFIED:
ALL DIODES SILICON, 92115021
ALL TRANSISTORS, SNPN, 2N3646, 50210310
DELAY TIMES ARE NOMINAL
 - TRANSISTOR, SPNP, 2N4258, 50211510.
 - ALL IC'S HAVE PIN 7 CONNECTED TO GND; PIN 14 TO +5V
 - DELAY TIMES FOR REFERENCE ONLY.

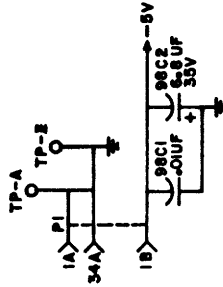

SHEET REVISION STATUS		REVISION RECORD	
REV	ECO	DESCRIPTION	DATE
A	PEZ3000	RELEASED	5-7-71

REFERENCE DRAWINGS		CONTROL DATA	
COMP ASSY	54219900	CORPORATION	NORMANDALE DIVISION
U.S.T.	SELCON	DIVN	BR2A5B
CHK	D. MESKE	ENGR	4-10-71
ENG	H. Kasper	MFG	4-13-71
APP	<i>[Signature]</i>	APPR	4-30-71
TOLERANCE VALUE RATING		DRAWING NUMBER	
RES	± 5%	19333	C 542190012
CAP	± 20%	CODE IDENT	
		19333	
		DRAWING NUMBER	
		C 542190012	
		SHEET 1 OF 3	

**SCHEMATIC DIAGRAM
OUTPUT CONTROL 2
TYPE 1EYV**

54219001

REV	ECO	DESCRIPTION	DWGT	DATE	CHKD	APP
SEE SHEET 1 FOR REV						
SR						

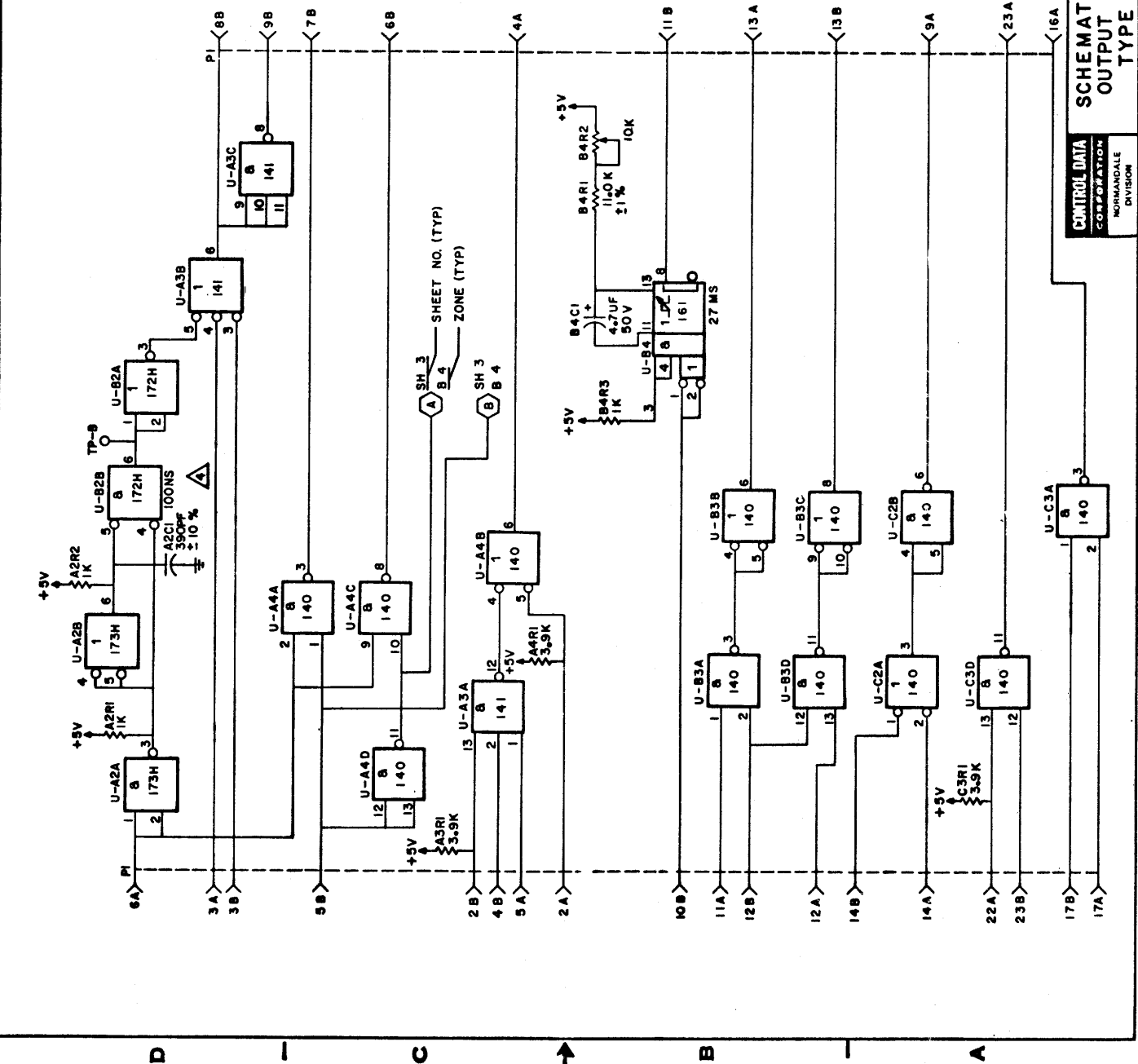

CONTROL DATA		CODE IDENT	DWG NO	C.D.
CORPORATION		19333	C 54219001	2
DIVISION				
NORMANDE				
SHEET 2				

SCHEMATIC DIAGRAM
OUTPUT CONTROL 2
TYPE 1EYV

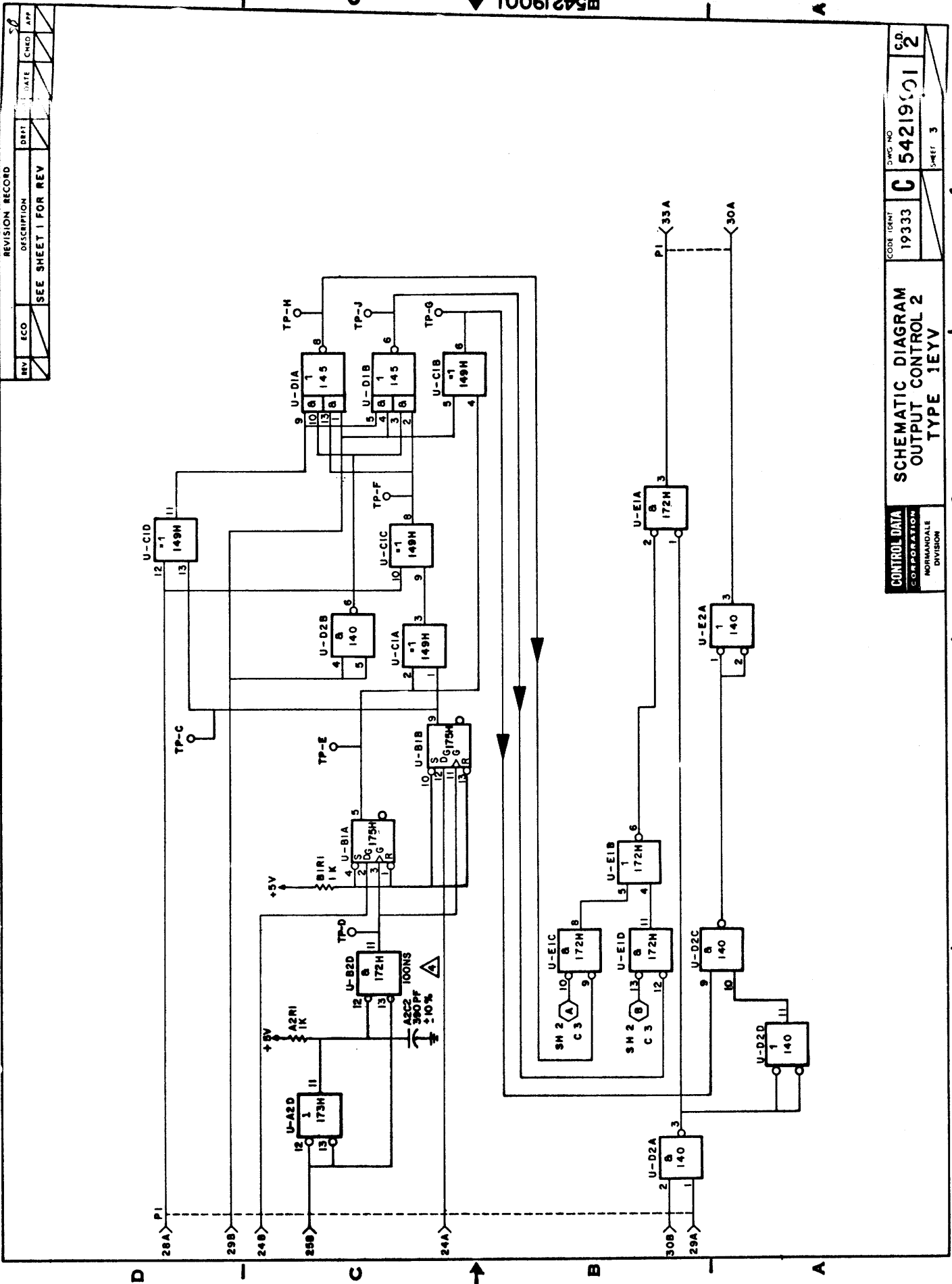

REVISION RECORD			
REV	ECO	DESCRIPTION	DATE
1		SEE SHEET 1 FOR REV	

CONTROL DATA		SCHEMATIC DIAGRAM 2	
CORPORATION		OUTPUT CONTROL 2	
NORMANVILLE DIVISION		TYPE 1EYV	
CODE IDENT	DWG NO	C.D.	SHEET
19333	5421901	2	3

BS4219001

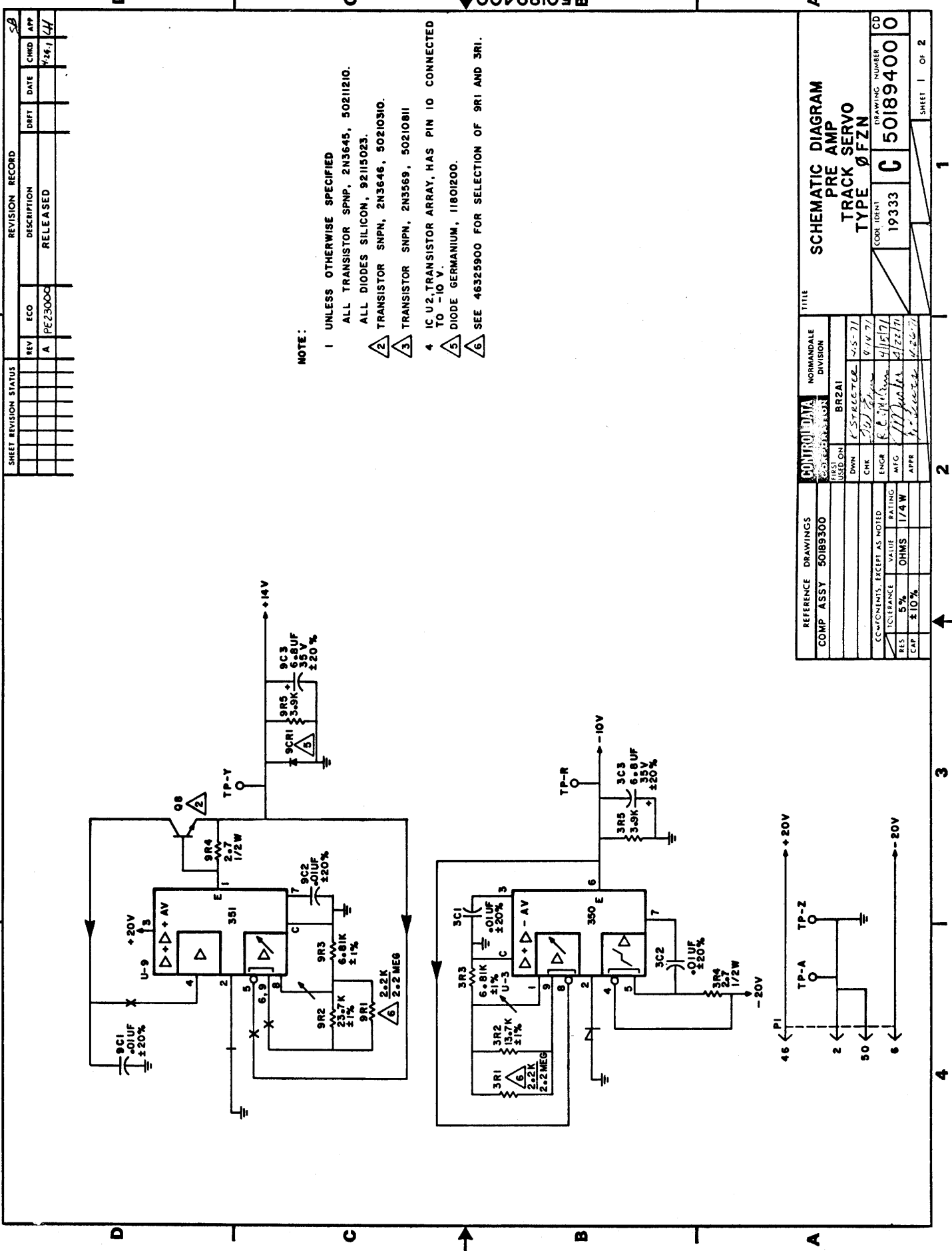

NOTE:

- 1 UNLESS OTHERWISE SPECIFIED
ALL TRANSISTOR SPNP, 2N3645, 50211210.
ALL DIODES SILICON, 92115023.
- 2 TRANSISTOR SNPN, 2N3646, 50210310.
- 3 TRANSISTOR SNPN, 2N3569, 50210811
- 4 IC U2 TRANSISTOR ARRAY, HAS PIN 10 CONNECTED TO -10 V.
- 5 DIODE GERMANIUM, 11801200.
- 6 SEE 46325900 FOR SELECTION OF 9R1 AND 3R1.

SHEET REVISION STATUS		REVISION RECORD	
REV	ECO	DESCRIPTION	DATE
A	PE2300C	RELEASED	4/26/71

REFERENCE DRAWINGS	CONTROL DATA	TITLE
COMP ASSY 50189300	UNST. SECTION BR2A1	SCHEMATIC DIAGRAM PRE AMP TRACK SERVO TYPE ØFZN
	DESIGNATION	
	ENGR	19333
	MFG	4/15/71
	APPR	4/26/71
COMPONENTS, EXCEPT AS NOTED		DRAWING NUMBER
TOLERANCE VALUE RATING		50189400
RES 5% OHMS 1/4W		19333
CAP ±10%		ØFZN
		COOK IDENT
		19333
		DRAWING NUMBER
		50189400
		SHEET 1 OF 2

50189400

7-146.6

REVISION RECORD			
REV	ECO	DESCRIPTION	DATE
1		SEE SHT 1 FOR REV	

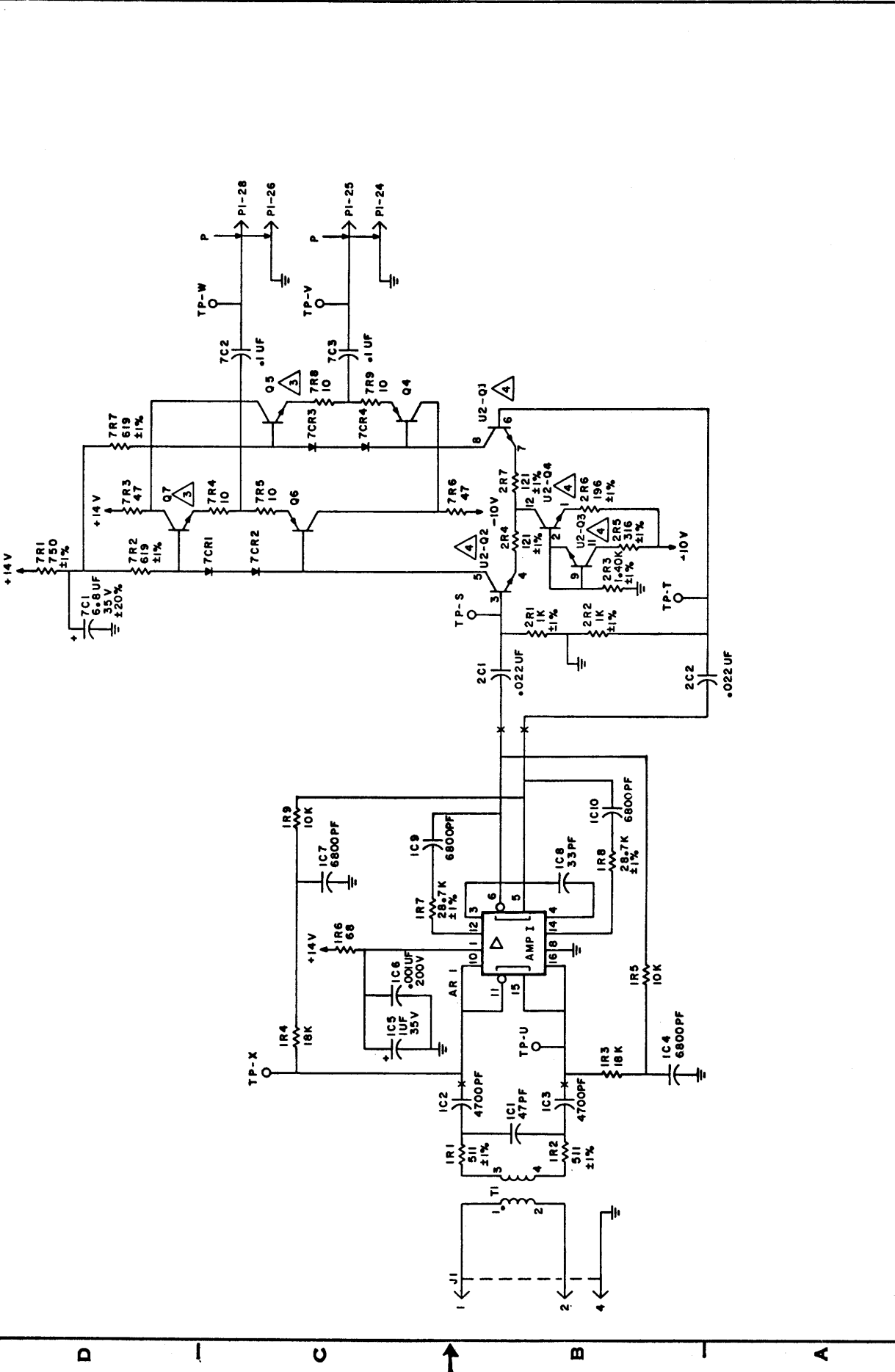

CD	0
DWG NO	50189400
COE TRNT	1933
SCHEMATIC DIAGRAM	
PRE AMP TRACK SERVO	
TYPE ØFZN	
NORMAN DALE DIVISION	
SHEET 2 OF 2	

B50189400

70616800 D

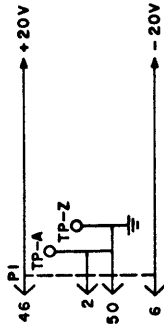
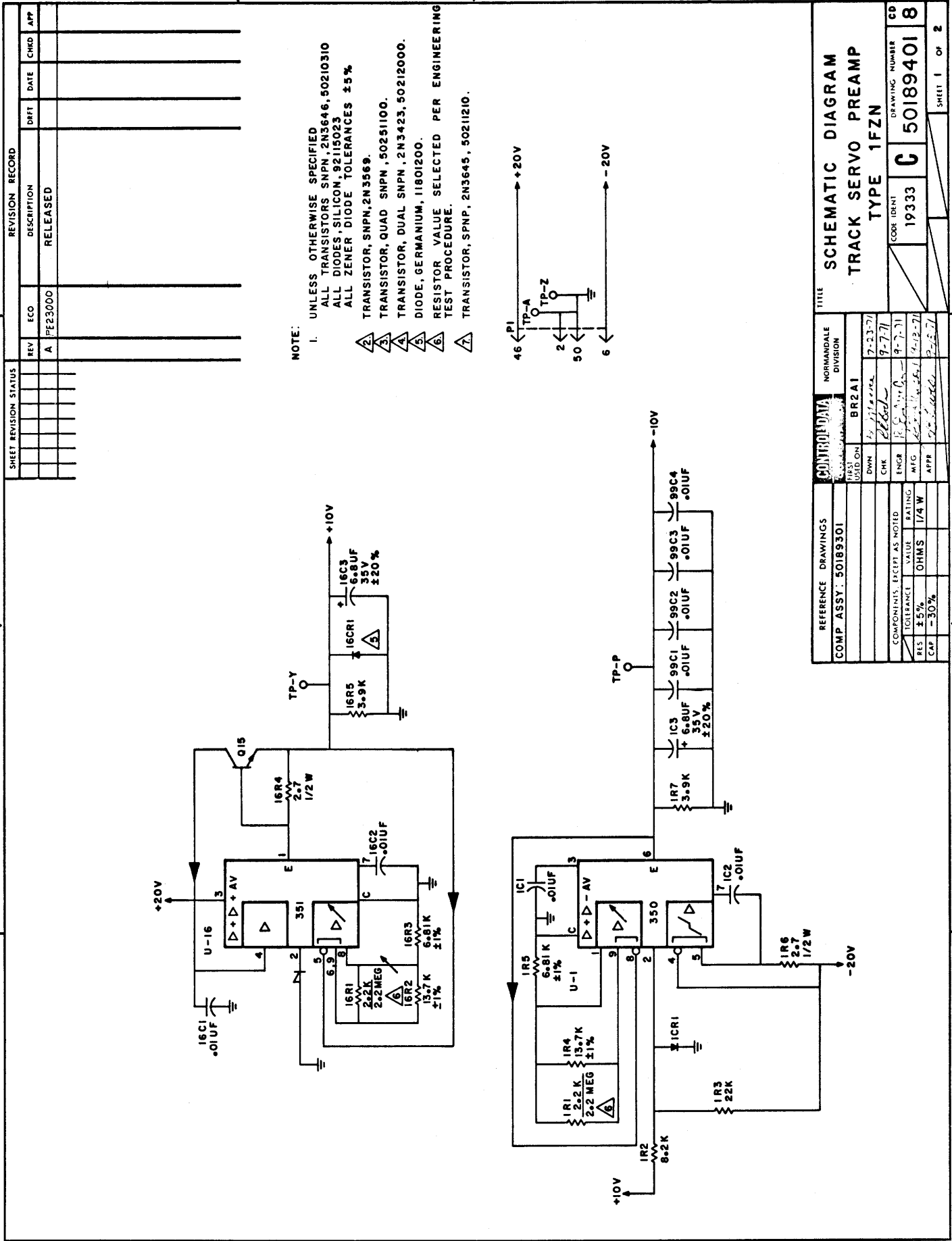

SHEET REVISION STATUS		REVISION RECORD	
REV	ECO	DESCRIPTION	DRFT DATE
A	FE23000	RELEASED	

REFERENCE DRAWINGS	COMPONENTS, EXCEPT AS NOTED	TOLERANCE	VALUE	RATING
COMP ASSY. 50189301		$\pm 5\%$	OHMS	1/4 W
		-30%		

CONTROL DATA	NORMANDEALE DIVISION
FIRST USED ON	BR 2 A 1
CHK	7-23-71
ENGR	9-7-71
MFG	11-12-71
APPR	2-2-71

TITLE		SCHEMATIC DIAGRAM	
COMP ASSY. 50189301		TRACK SERVO PREAMP	
TYPE 1FZN		COORDINATE	19333
		DRAWING NUMBER	50189401
			8
		SHEET 1 OF 2	

B50189401

REVISION RECORD			
REV	ECO	DESCRIPTION	DRFT DATE
1		SEE SHEET 1 FOR REV	
2			
3			
4			

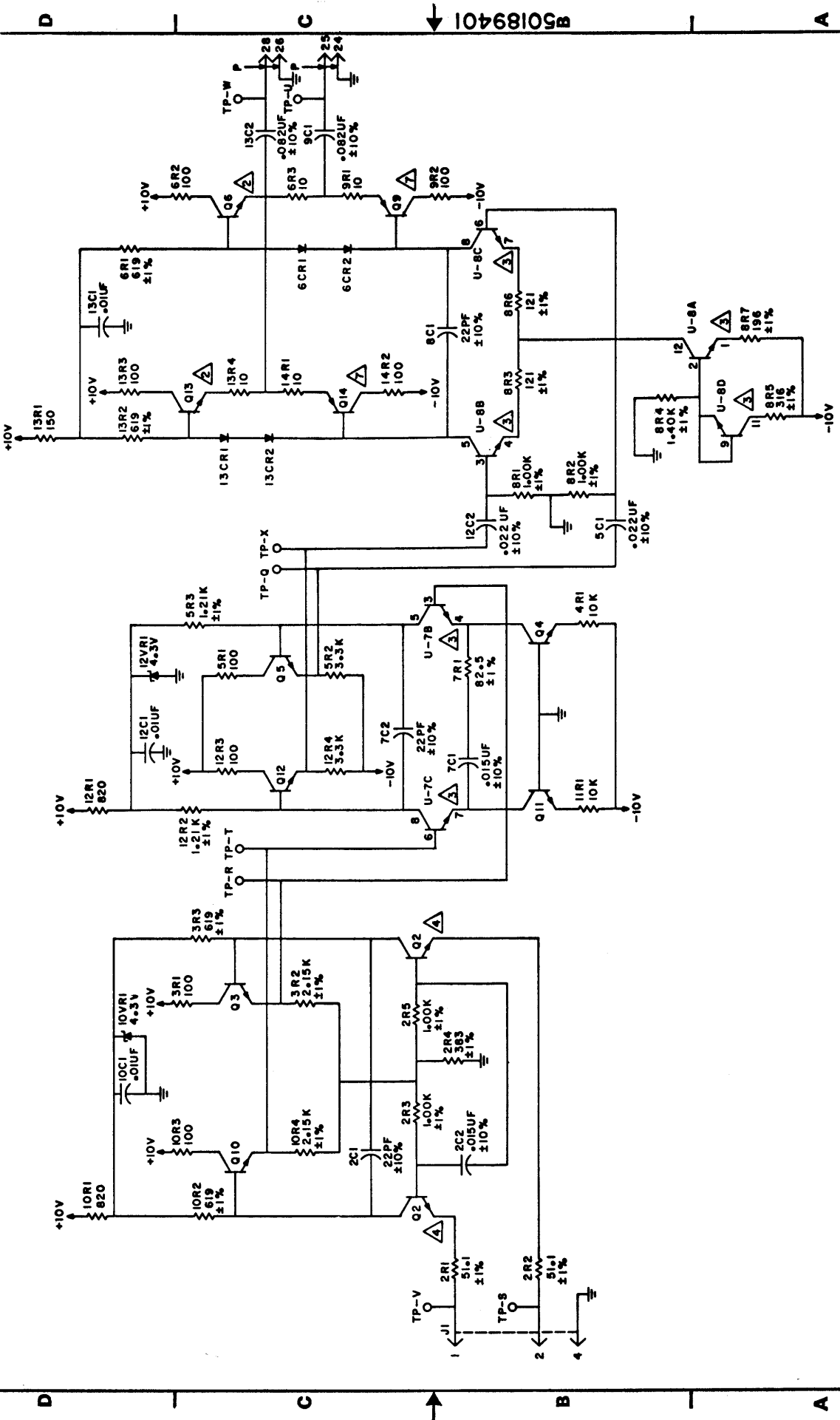

REV	ECO	DESCRIPTION	DRFT DATE	CHKD	APP
1		SEE SHEET 1 FOR REV			

CONTROL DATA	NONMARRIALE DIVISION
--------------	----------------------

CODE IDENT	DWG NO
19333	C 50189401
SCHEMATIC DIAGRAM TRACK SERVO PREAMP TYPE 1FZN	
SHEET 2	

REVISION RECORD

REV	ECO	DESCRIPTION	DATE	CHKD	APP
A	PE-31330	RELEASED	2-13-73		

SHEET DIVISION STATUS

--	--	--	--	--	--	--	--	--	--	--	--

NOTES:

- 1 UNLESS OTHERWISE SPECIFIED:
ALL 16 PIN IC'S HAVE PIN 8 CONNECTED TO GROUND AND PIN 16 CONNECTED TO +5V.
- ALL 14 PIN IC'S HAVE PIN 7 CONNECTED TO GROUND AND PIN 14 CONNECTED TO +5V.
- 2 TEST SELECT RESISTORS TO BE SELECTED FROM DRAWING 94387500 AND INSERTED DURING CARD TEST PER RECOMMENDED TEST PROCEDURE.
- 3 DELAY TIME FOR REFERENCE ONLY.
- 4 IC'S U-A3 AND U-B3 HAVE PIN 13 CONNECTED TO -5V.

D

C

1

2

3

4

↑

3

4

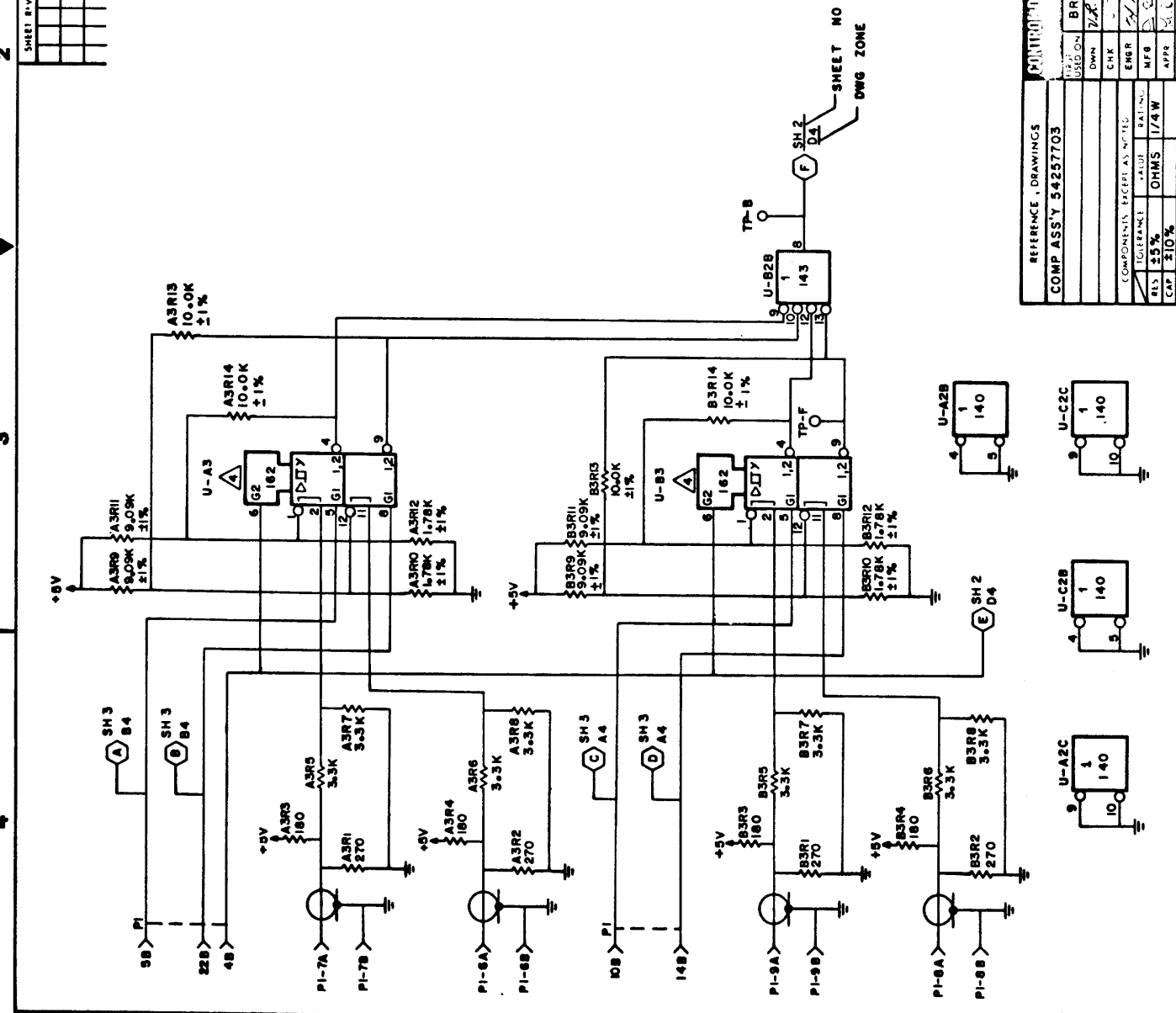

D

C

B

A

1

2

3

4

↑

1

2

3

4

B 54257803

A

TITLE SCHEMATIC DIAGRAM WRITE BLOT SIMULATION WRITE BLOT CONVERSION TYPE 3JV		CORE IDENT 19333		DRAWING NUMBER 54257803	C.D. 4
REFERENCE, DRAWINGS COMP ASS'Y 54257703		CONTROLDATA BR3ABB NORMANDALE DIVISION		DRAWING NUMBER 54257803	
DATE 2-13-73	DESIGNED BY <i>J.P. O'Connell</i>	CHK'D <i>[Signature]</i>	DATE 2-13-73	DRAWING NUMBER 54257803	
ISS 25%	APPROVED BY <i>[Signature]</i>	DATE 2-13-73	DRAWING NUMBER 54257803		
CAP ±10%	SHEET NO. 1		SHEET 1 OF 3		

7-146.10

70616800 J

REVISION RECORD			
REV	ECO	DESCRIPTION	DATE
A		SEE SHEET 1 FOR REV	

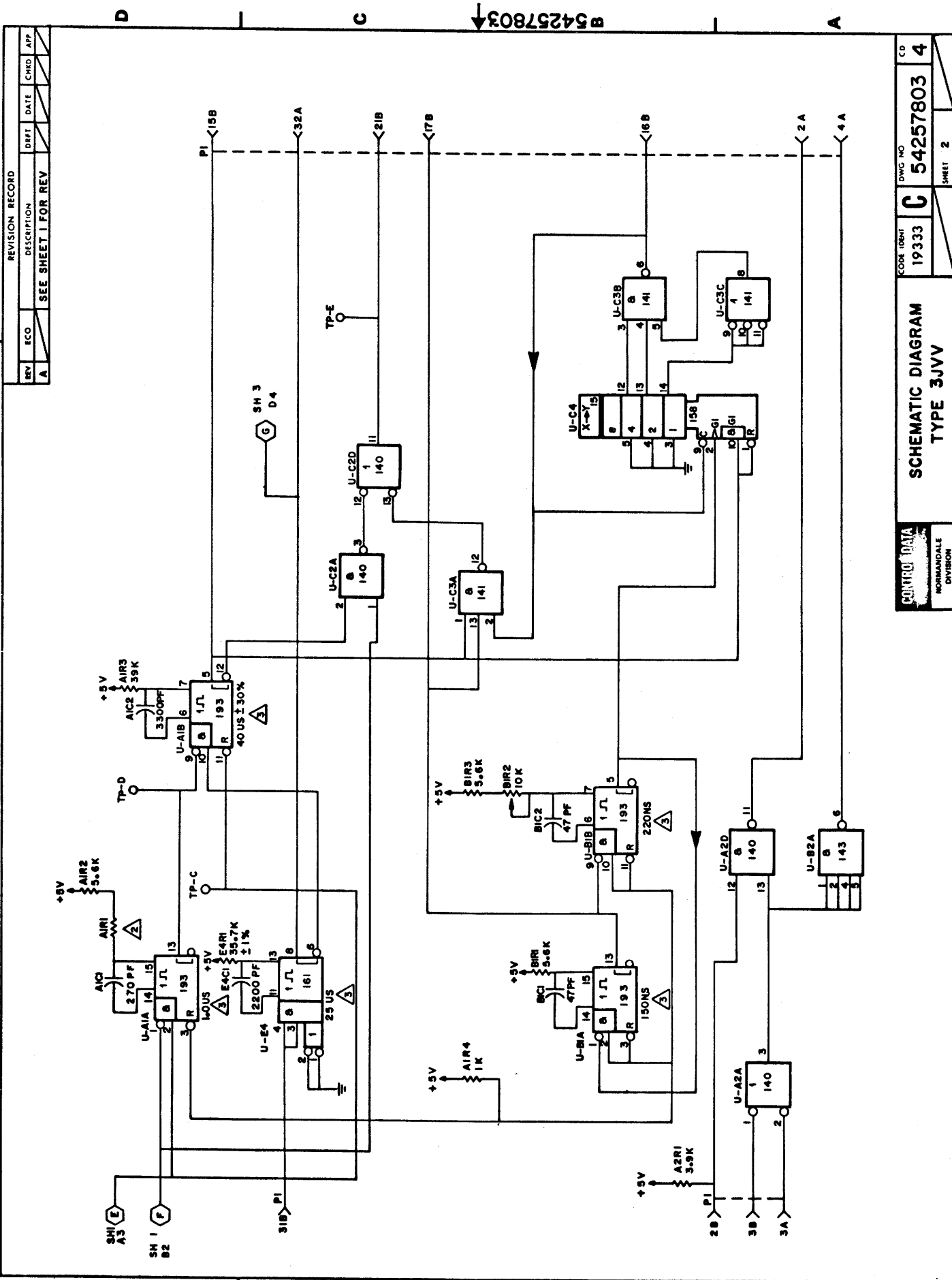

CONTROL DATA	NORMAN DALE DIVISION	SCHEMATIC DIAGRAM	CD
		TYPE 3JVV	4
19333	DWC NO	54257803	
SHEET 2			

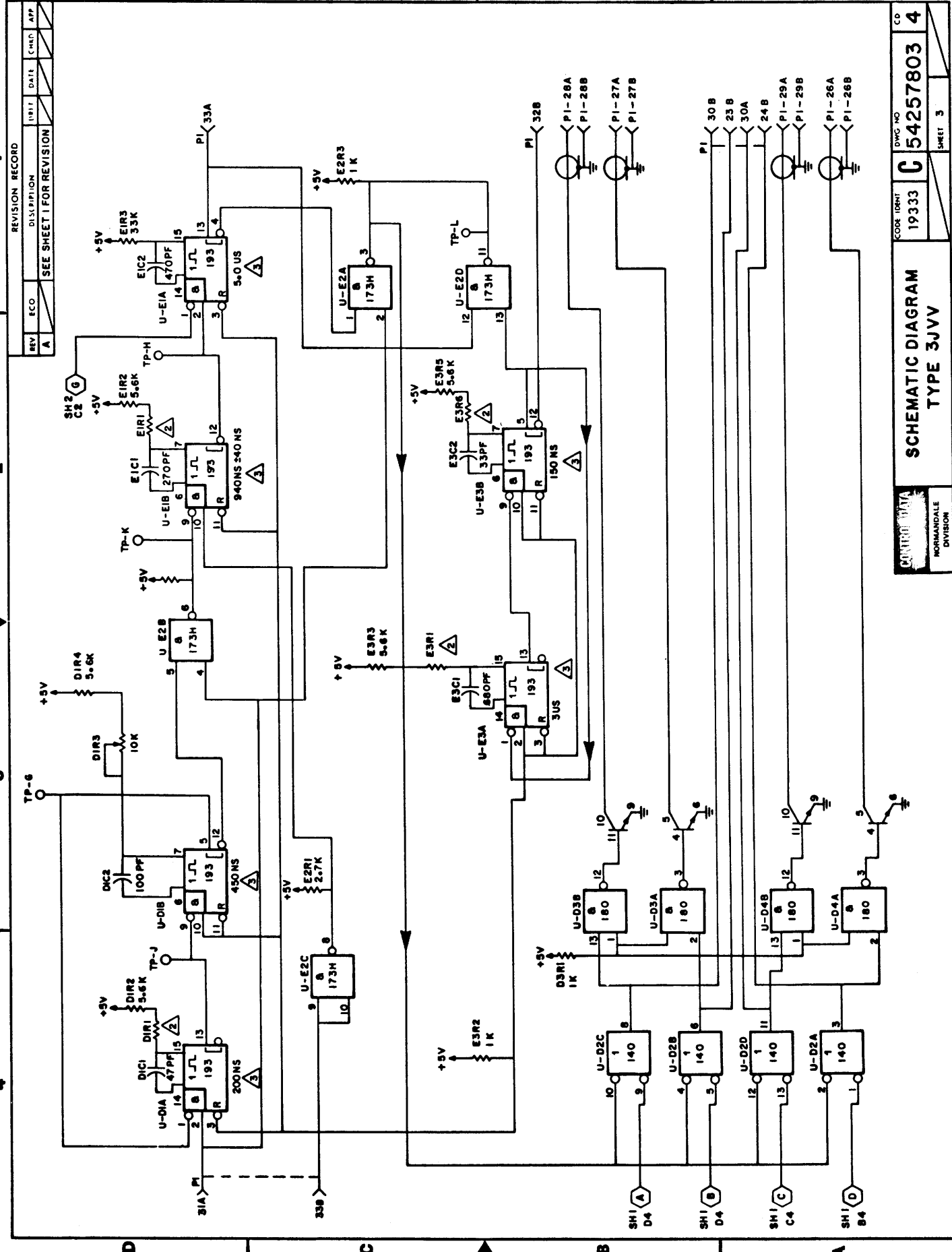

REV	ECO	DISPOSITION	DATE	CHKD	APP
A		SEE SHEET 1 FOR REVISION			

1
2
3
4

CD	DWG NO	4
CODE IDENT	C	54257803
SCHEMATIC DIAGRAM		SHEET 3
TYPE 3JVJ		
CAUTION: DATA NORMANDALE DIVISION		

1
2
3
4

B 54257803

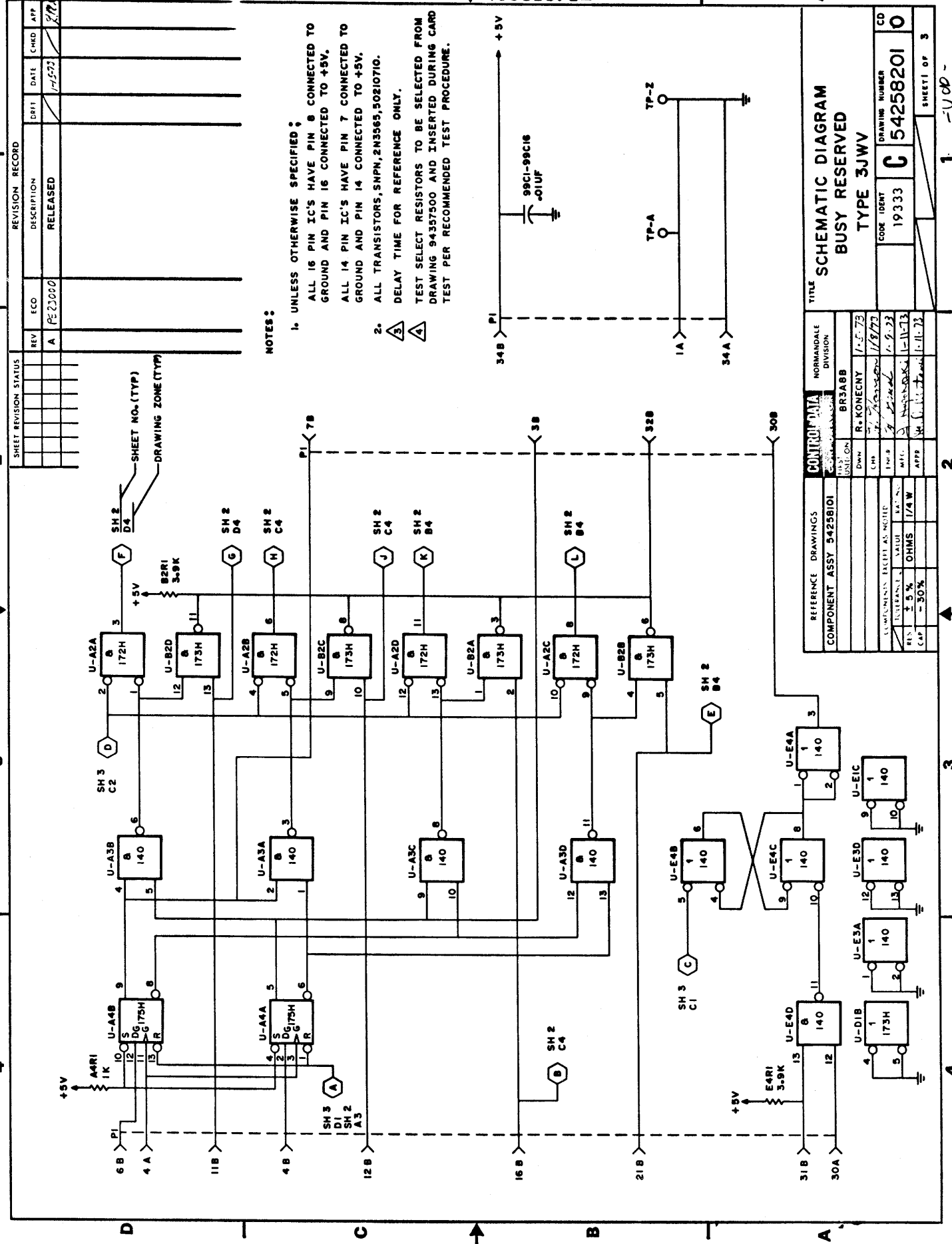

NOTES:
 1. UNLESS OTHERWISE SPECIFIED;
 ALL 16 PIN IC'S HAVE PIN 8 CONNECTED TO GROUND AND PIN 16 CONNECTED TO +5V.
 ALL 14 PIN IC'S HAVE PIN 7 CONNECTED TO GROUND AND PIN 14 CONNECTED TO +5V.
 ALL TRANSISTORS, SNPN, 2N3585, 50210710.
 DELAY TIME FOR REFERENCE ONLY.
 2. Δ TEST SELECT RESISTORS TO BE SELECTED FROM DRAWING 94357500 AND INSERTED DURING CARD TEST PER RECOMMENDED TEST PROCEDURE.

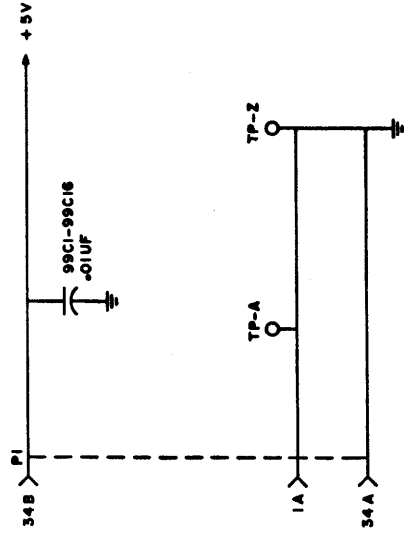

SHEET REVISION STATUS		REVISION RECORD			
REV	ECO	DESCRIPTION	DRIT	DATE	CHKD APP
A	FE23000	RELEASED		1-15-73	

REFERENCE DRAWINGS		CONTROL DATA		NORMANDALE DIVISION	
COMPONENT ASSY	54258101	UNIT ON	BR348B	DWN	R. KONECNY 1-5-73
DESIGNER		CHKD		APP	1-9-73
DATE		DATE		DATE	1-11-73
RES	± 5%	OHMS	1/4 W	APP	1-11-73
CAP	- 30%				

TITLE			
SCHEMATIC DIAGRAM			
BUSY RESERVED			
TYPE 3JWV			
CODE IDENT	19333	DRAWING NUMBER	C 54258201
CD			0

SHEET OF 3
 1 - UOD -

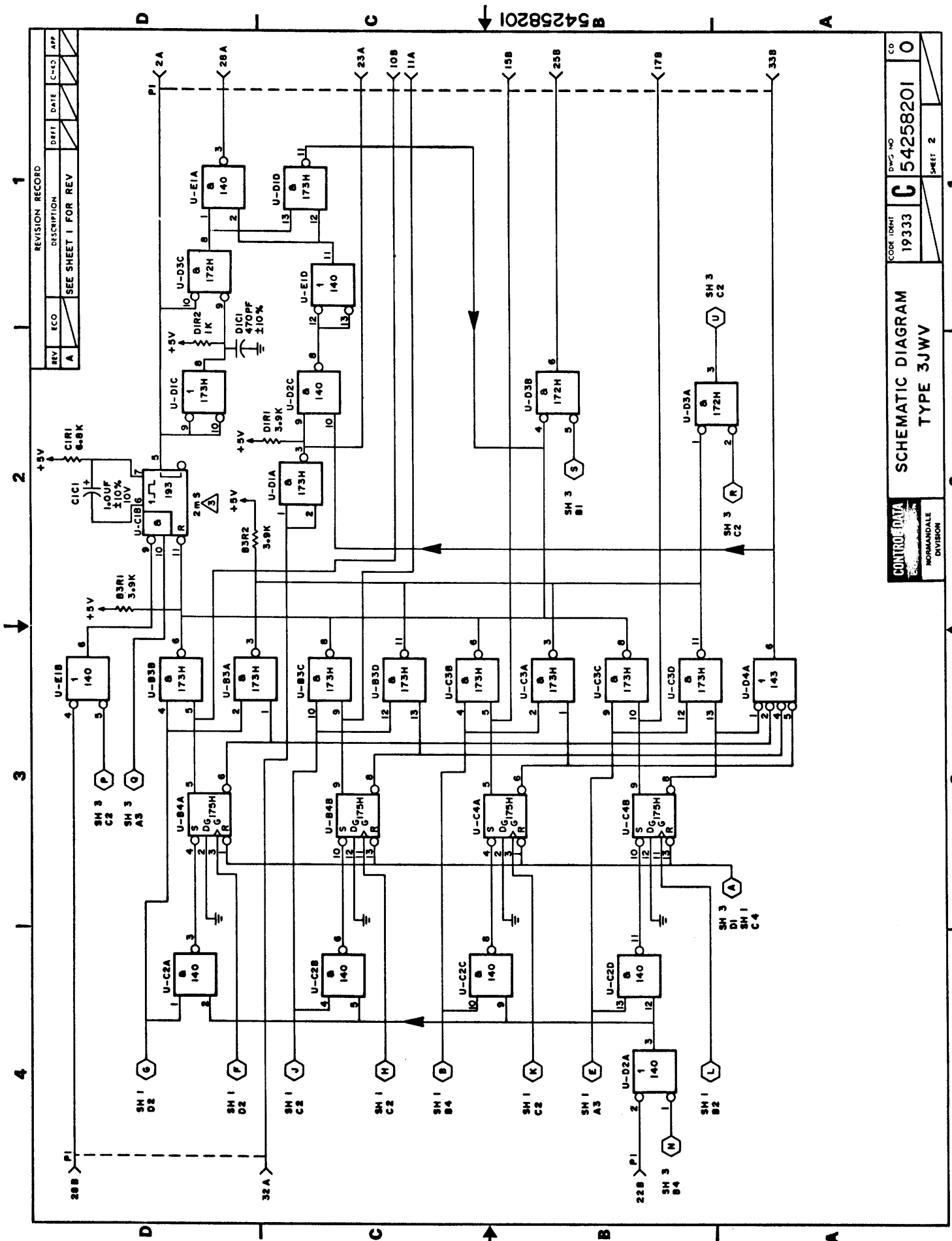

REV	ECO	DESCRIPTION	DATE	CHKD	APP
A		SEE SHEET 1 FOR REV			

CONTROL DATA
NORMANDEALE
DIVISION

SCHEMATIC DIAGRAM
TYPE 3JWV

CODE IDENT 19333
DWG NO C 54258201
SHEET 2

1 2 3 4

A B C D

← B54258201 →

REV	ECO	DESCRIPTION	DWGT	DATE	CHKD	APP
A		SEE SHEET 1 FOR REV				

REVISION RECORD						
1						

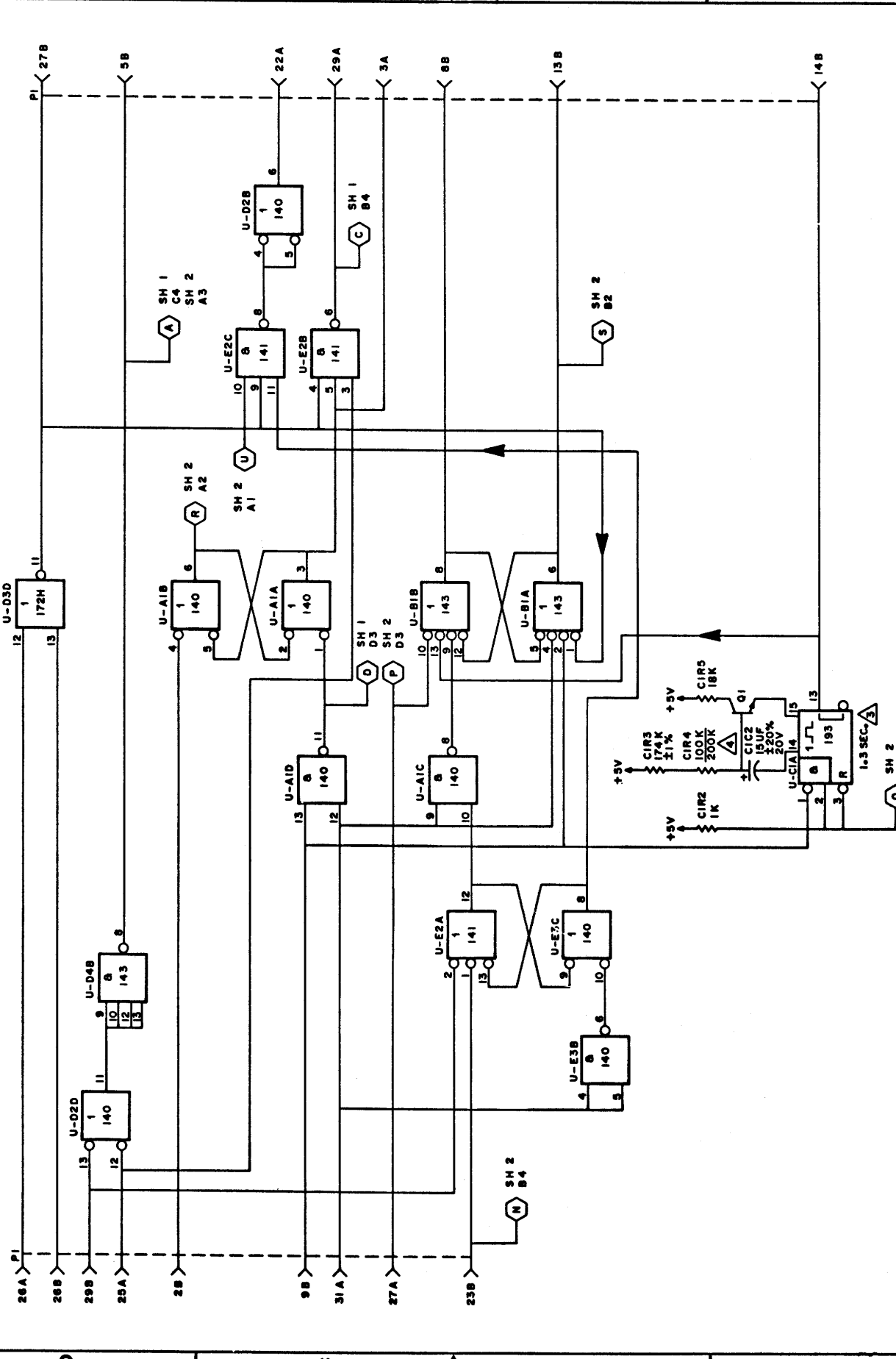

CD	DWG NO	SHEET
19333	C 54258201	3
SCHEMATIC DIAGRAM		
TYPE 3JWV		
NORMAN DALE DIVISION		

SHEET REVISION STATUS		REVISION RECORD				
REV	ECO	DESCRIPTION	DRFT	DATE	CHRD	APP
A	PC23000	RELEASED		7-5-73		

NOTES:
 1- UNLESS OTHERWISE SPECIFIED:
 ALL 16 PIN IC'S HAVE PIN 8 CONNECTED TO GROUND AND PIN 16 CONNECTED TO +5V.
 ALL 14 PIN IC'S HAVE PIN 7 CONNECTED TO GROUND AND PIN 14 CONNECTED TO +5V.

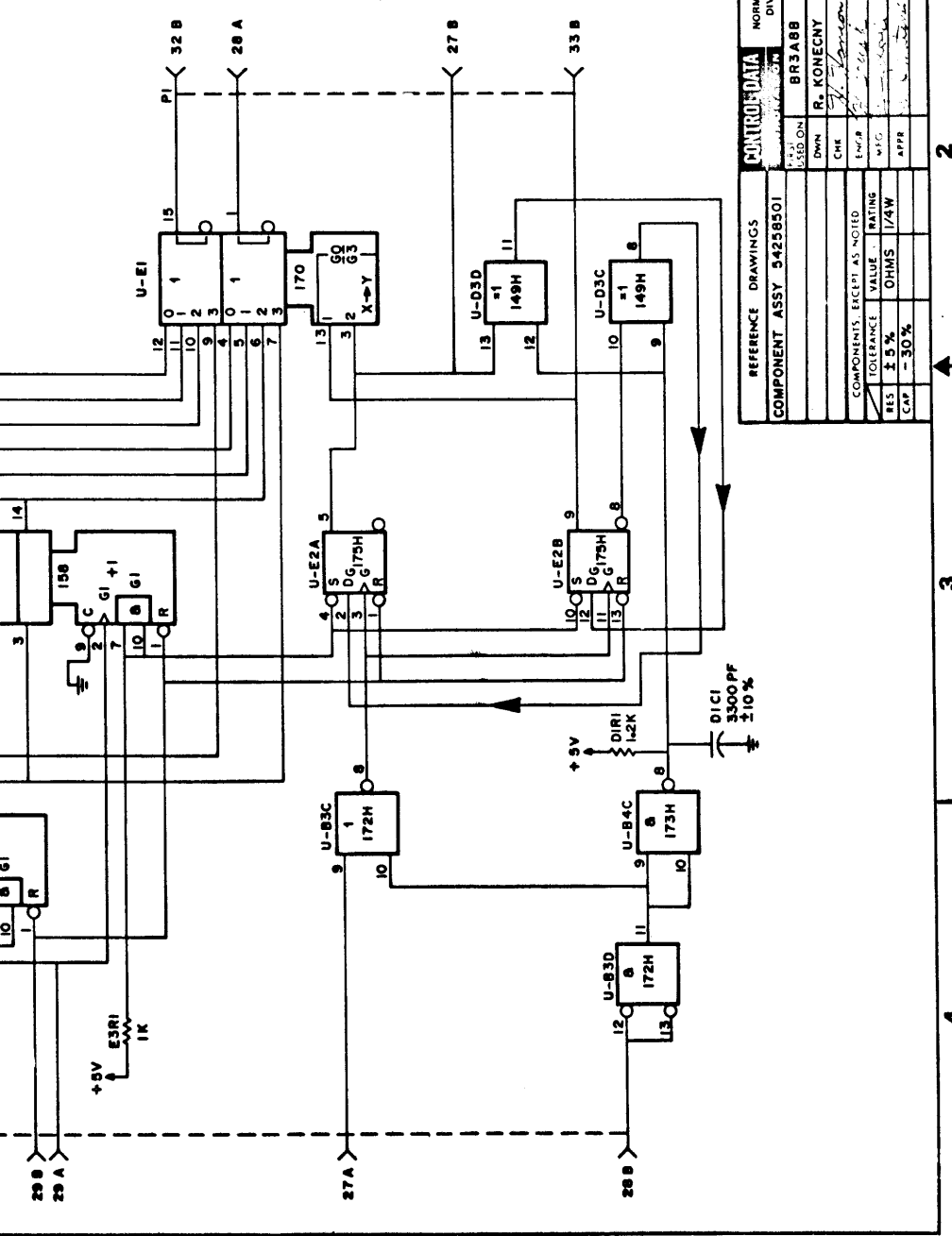

REFERENCE DRAWINGS		CONTOUR DATA		NORMANDEALE DIVISION	
COMPONENT ASSY 54258601		BR3A8B		DWN B. KONECNY	
DATE 1-1-73		CHK E. J. Konecny		DATE 1-9-73	
DRAWN BY		ENGR BY		DATE	
TOLERANCE VALUE		RATING		DATE	
RES ± 5%		OHMS 1/4W		DATE	
CAP - 30%		APPR		DATE	
TITLE				DRAWING NUMBER	
SCHEMATIC DIAGRAM				C 54258601	
HEAD BUFFER				COR IDENT	
TYPE 3JXV				19333	
SHEET 1 OF 3					

REVISION RECORD			
REV	ECO	DESCRIPTION	DATE
A		SEE SHEET 1 FOR REV	

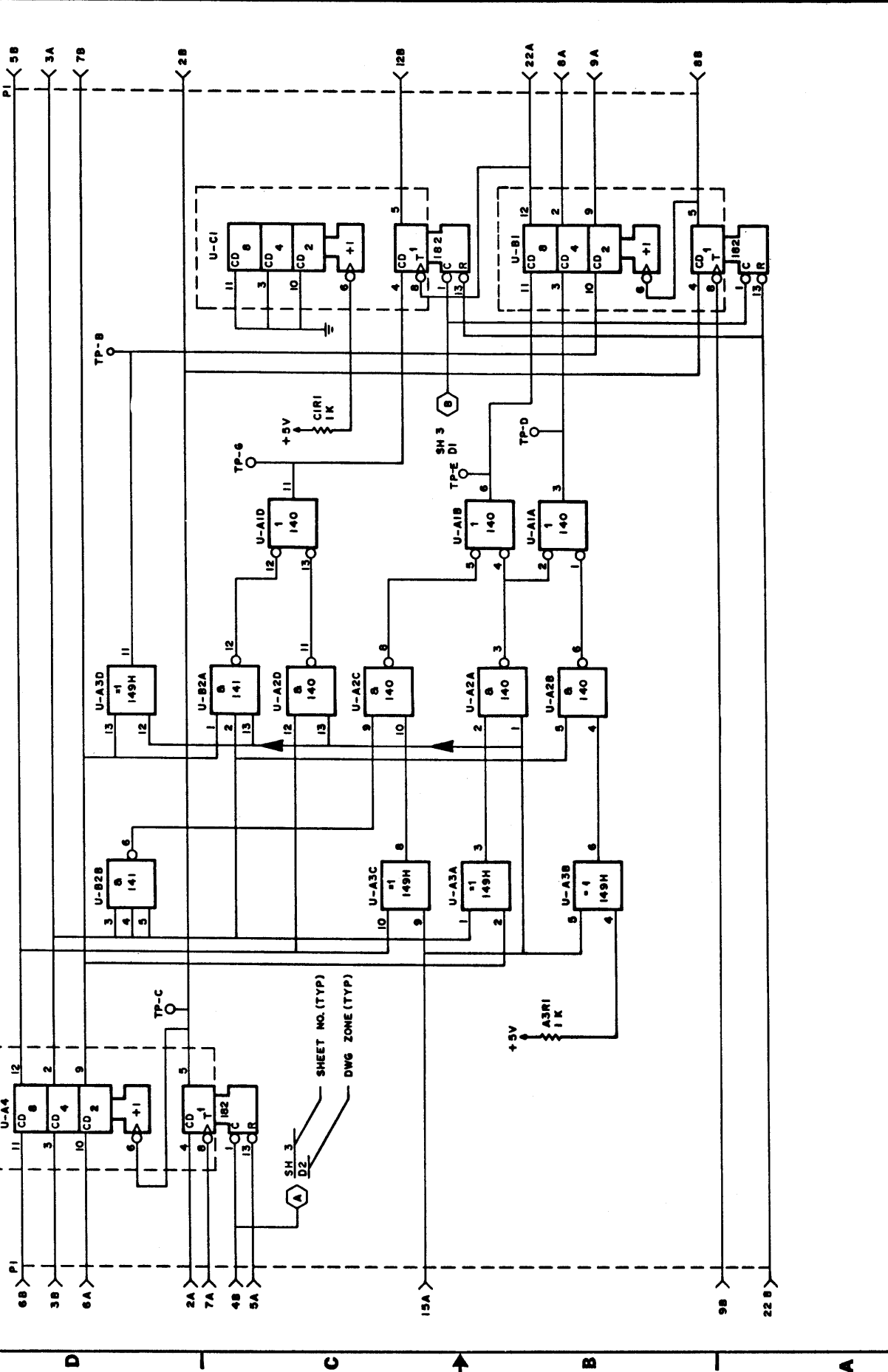

CONTROL DATA CORPORATION
NORMANVILLE DIVISION

SCHEMATIC DIAGRAM
TYPE 3JXV

CODE IDENT 19333
DWG NO 54258601
SHEET 2

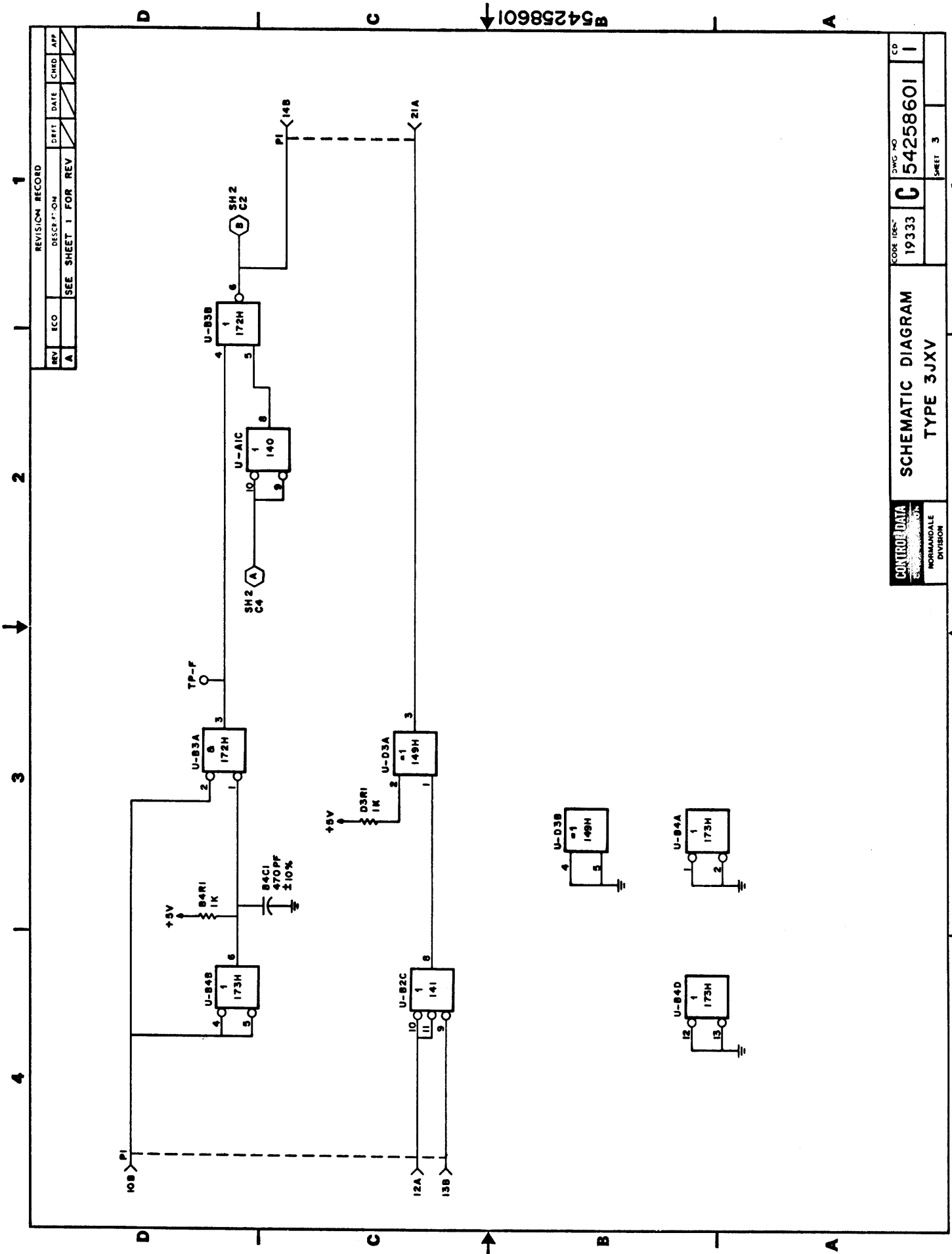

54258601

1
2
3
4

1
2
3
4

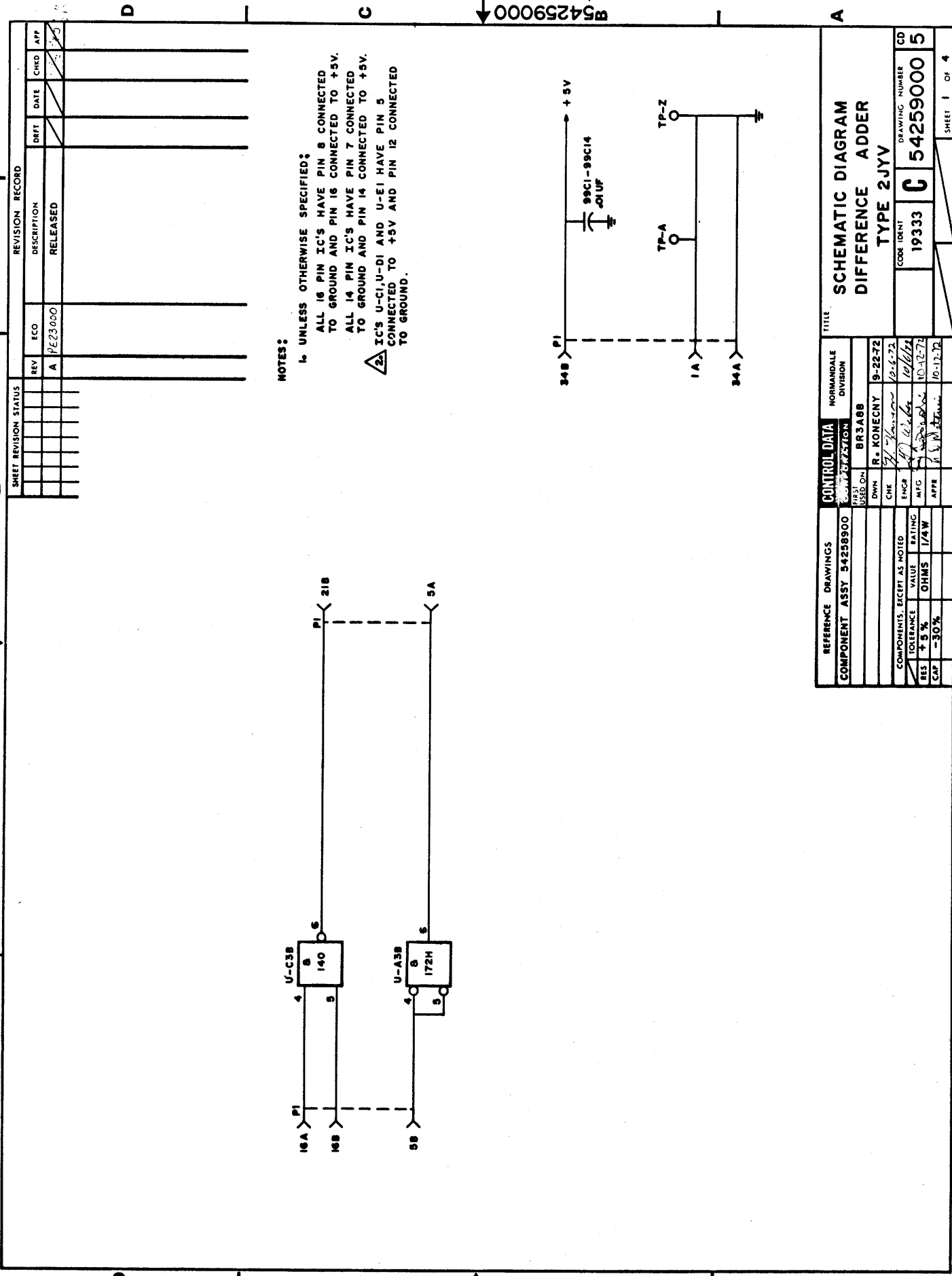

NOTES:
 1. UNLESS OTHERWISE SPECIFIED:
 ALL 16 PIN IC'S HAVE PIN 8 CONNECTED TO GROUND AND PIN 16 CONNECTED TO +5V.
 ALL 14 PIN IC'S HAVE PIN 7 CONNECTED TO GROUND AND PIN 14 CONNECTED TO +5V.
 2. IC'S U-C1, U-D1 AND U-E1 HAVE PIN 5 CONNECTED TO +5V AND PIN 12 CONNECTED TO GROUND.

SHEET REVISION STATUS		REVISION RECORD				
REV	ECO	DESCRIPTION	DRFT	DATE	CHKD	APP
A	P223000	RELEASED				

REFERENCE DRAWINGS		CONTROL DATA		NORMANDALE DIVISION		TITLE	
COMPONENT ASSY 5425900		BR3A8B		9-22-72		SCHEMATIC DIAGRAM	
FIRST USED ON		DWN		R. KONECNY		DIFFERENCE ADDER	
CHK		ENG		10-6-72		TYPE 2JYV	
COMPONENTS, EXCEPT AS NOTED		MFG		10-12-72		CODE IDENT	
TOLERANCE VALUE		APPR		10-12-72		19333	
RES +5%						DRAWING NUMBER	
CAP -30%						54259000 5	
						SHEET 1 OF 4	

HDD

54259000

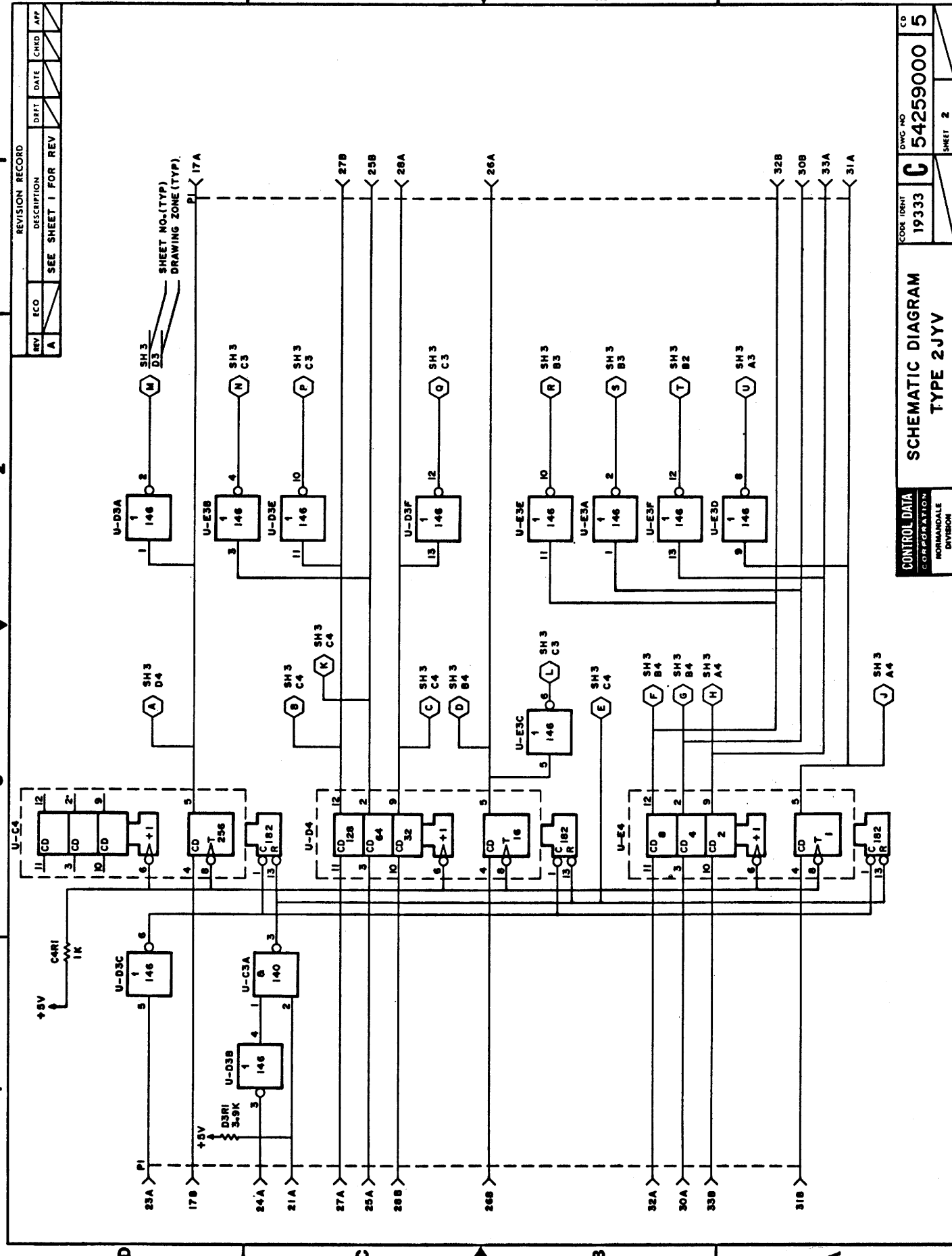

REVISION RECORD				
REV	ECO	DESCRIPTION	DRFT DATE	CHND APP
A		SEE SHEET 1 FOR REV		

SHEET NO. (TYP)
DRAWING ZONE (TYP)

CONTROL DATA		SCHEMATIC DIAGRAM		TYPE 2JYV	
CD	DWG NO	CODE DRFT	DWG NO	CD	SHEET 2
19333	C	54259000	5		

REVISION RECORD			
REV	ECO	DESCRIPTION	DRFT DATE
A		SEE SHEET 1 FOR REV	

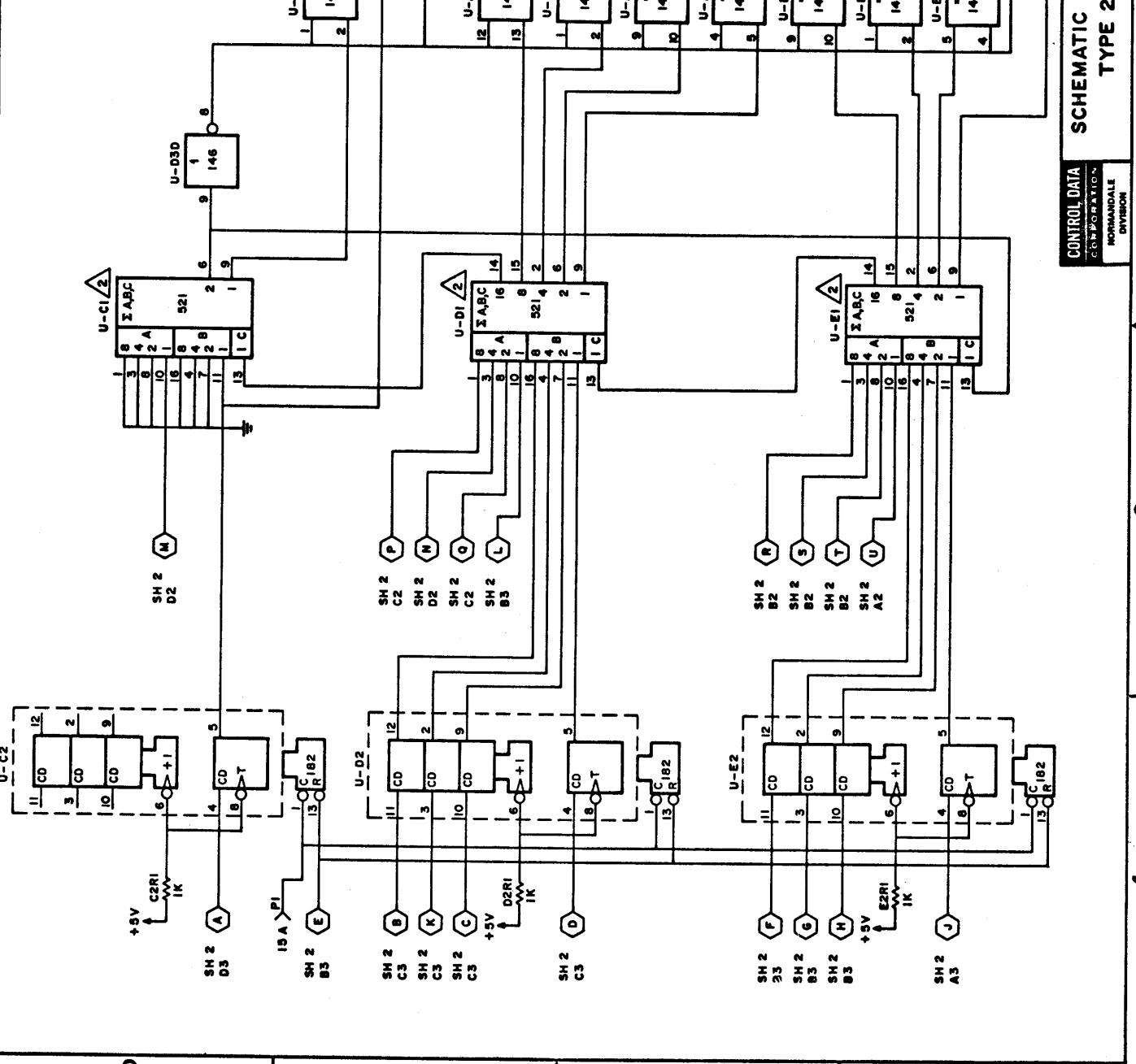

70616800 G

7-146.21

B 54259000 ↓

REV	DESCRIPTION	DRFT DATE	CHND APP
A	SEE SHEET 1 FOR REV		

DWC NO 54259000 5
CODE IDENT 19333 G
CONTROL DATA CORPORATION
NORMANVILLE DIVISION

**SCHEMATIC DIAGRAM
TYPE 2JYV**

SHEET 3

B54259000 ↓

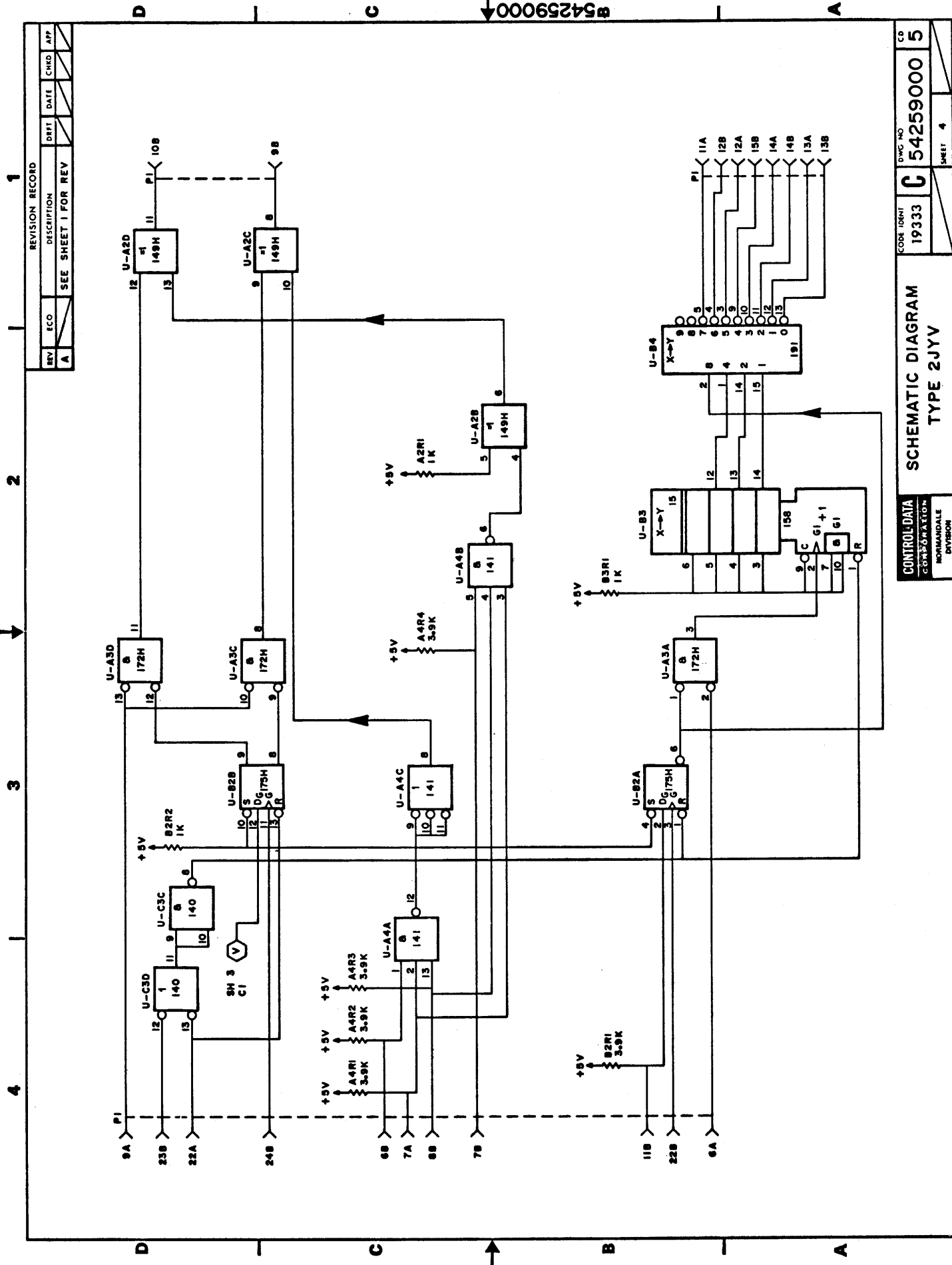

REVISION RECORD			
REV	ECO	DESCRIPTION	DATE
A		SEE SHEET 1 FOR REV	

CONTROL DATA	CD
GENERAL INFORMATION	DWG NO
NONMANUAL DIVISION	19333
	C
	5
	SHEET 4

SCHEMATIC DIAGRAM
TYPE 2JYV

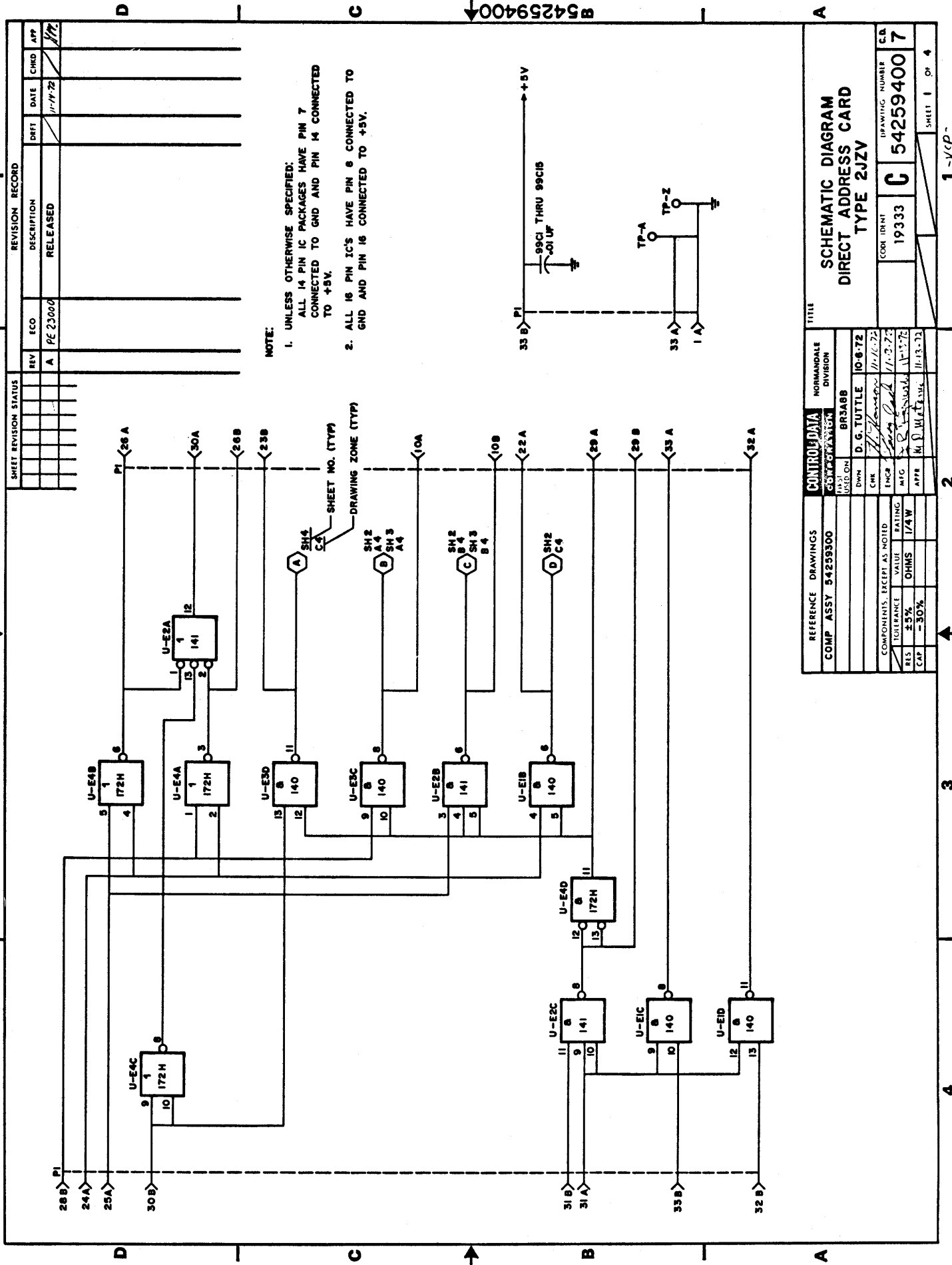

NOTE:

1. UNLESS OTHERWISE SPECIFIED:
ALL 14 PIN IC PACKAGES HAVE PIN 7
CONNECTED TO GND AND PIN 14 CONNECTED
TO +5V.
2. ALL 16 PIN IC'S HAVE PIN 6 CONNECTED TO
GND AND PIN 16 CONNECTED TO +5V.

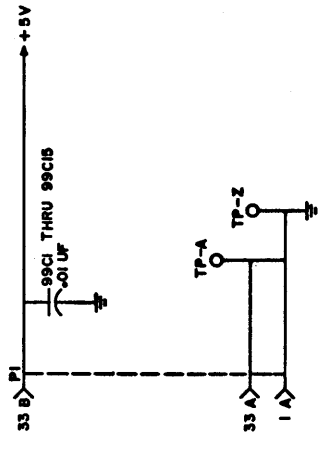

REVISION RECORD		DATE	CHKD	APP
REV	ECO	DESCRIPTION		
A	PE 23000	RELEASED		

SHEET REVISION STATUS	
1	
2	
3	
4	
5	
6	
7	
8	
9	
10	
11	
12	
13	
14	
15	
16	
17	
18	
19	
20	
21	
22	
23	
24	
25	
26	
27	
28	
29	
30	
31	
32	
33	
34	
35	
36	
37	
38	
39	
40	
41	
42	
43	
44	
45	
46	
47	
48	
49	
50	

REFERENCE DRAWINGS		CONTROL DATA		NORMANDALE DIVISION		TITLE	
COMP ASSY 54259300		COMP ASSY 54259300		BR3A8B		SCHEMATIC DIAGRAM	
COMPONENTS, EXCEPT AS NOTED		MACH USED ON		DWN		DIRECT ADDRESS CARD	
TOLERANCE VALUE		CHK		D. G. TUTTLE		TYPE 2JZV	
RES ±5%		ENGR		10-6-72		DRAWING NUMBER	
CAP -30%		FATIG		11-10-72		19333	
		1/4 W		11-13-72		CORR IDENT	
				11-13-73		C 54259400	
						DRAWING NUMBER	
						E.A.	
						7	
						SHEET 1 OF 4	

1-VCP-

B54259400

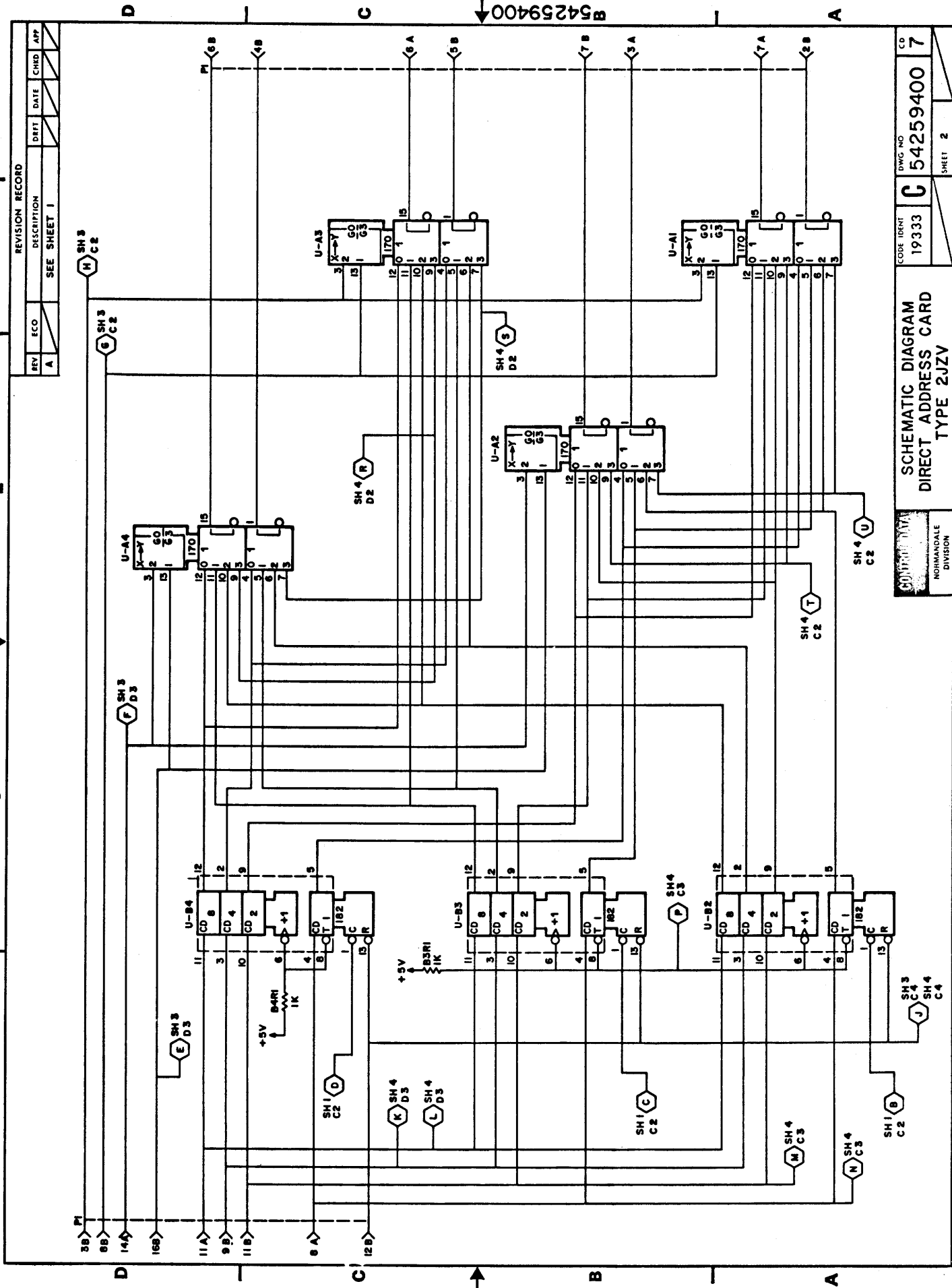

REVISION RECORD			
REV	ECO	DESCRIPTION	DATE
A		SEE SHEET 1	

CD	DWG NO	SHEET 2
19333	C 54259400	1
SCHEMATIC DIAGRAM		
DIRECT ADDRESS CARD		
TYPE 2JZV		
COMPTON DATA		
NORLANDALE DIVISION		

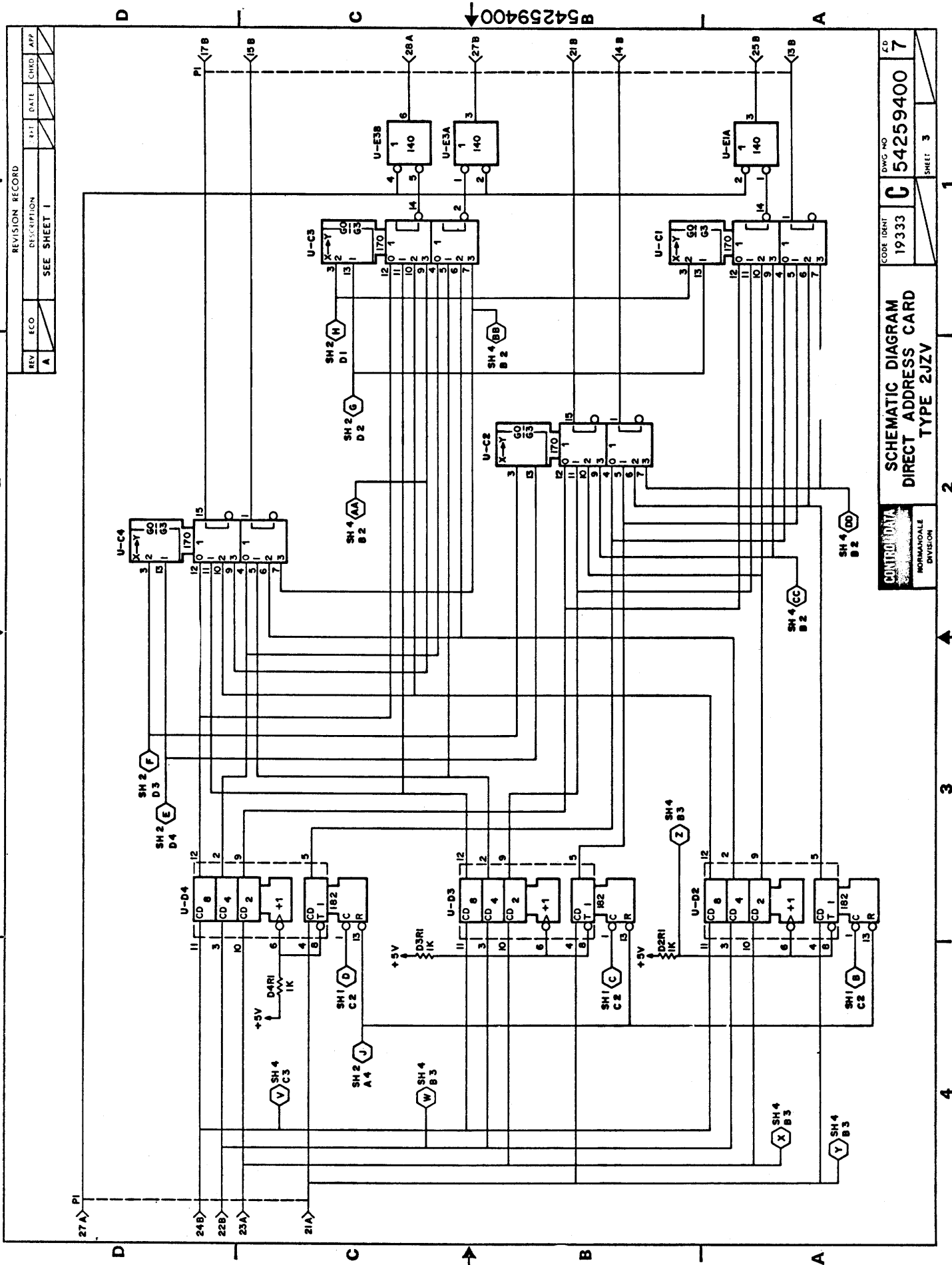

REVISION RECORD			
REV	ECO	DESCRIPTION	DATE
A		SEE SHEET 1	

SCHEMATIC DIAGRAM		DWG NO	CD
DIRECT ADDRESS CARD		C	54259400
CONTROL DATA		CODE IDENT	7
NORMANDALE DIVISION		19333	
		SHEET	3

B 54259400

REV	ECO	DESCRIPTION	DEPT	DATE	CHRD	APP
A		SEE SHEET 1				

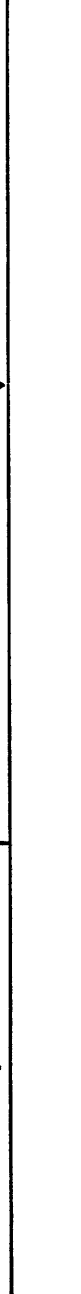

7-146.26

REVISION RECORD		CD
REV	ECO	CD
A		7

CONTROL DATA		DWG NO
CODE	DRNT	54259400
19333	C	

SCHEMATIC DIAGRAM		DWG NO
DIRECT ADDRESS CARD		54259400
TYPE 2JZY		

CORPORATION		SHEET
NORMANDALE		4

70616800 G

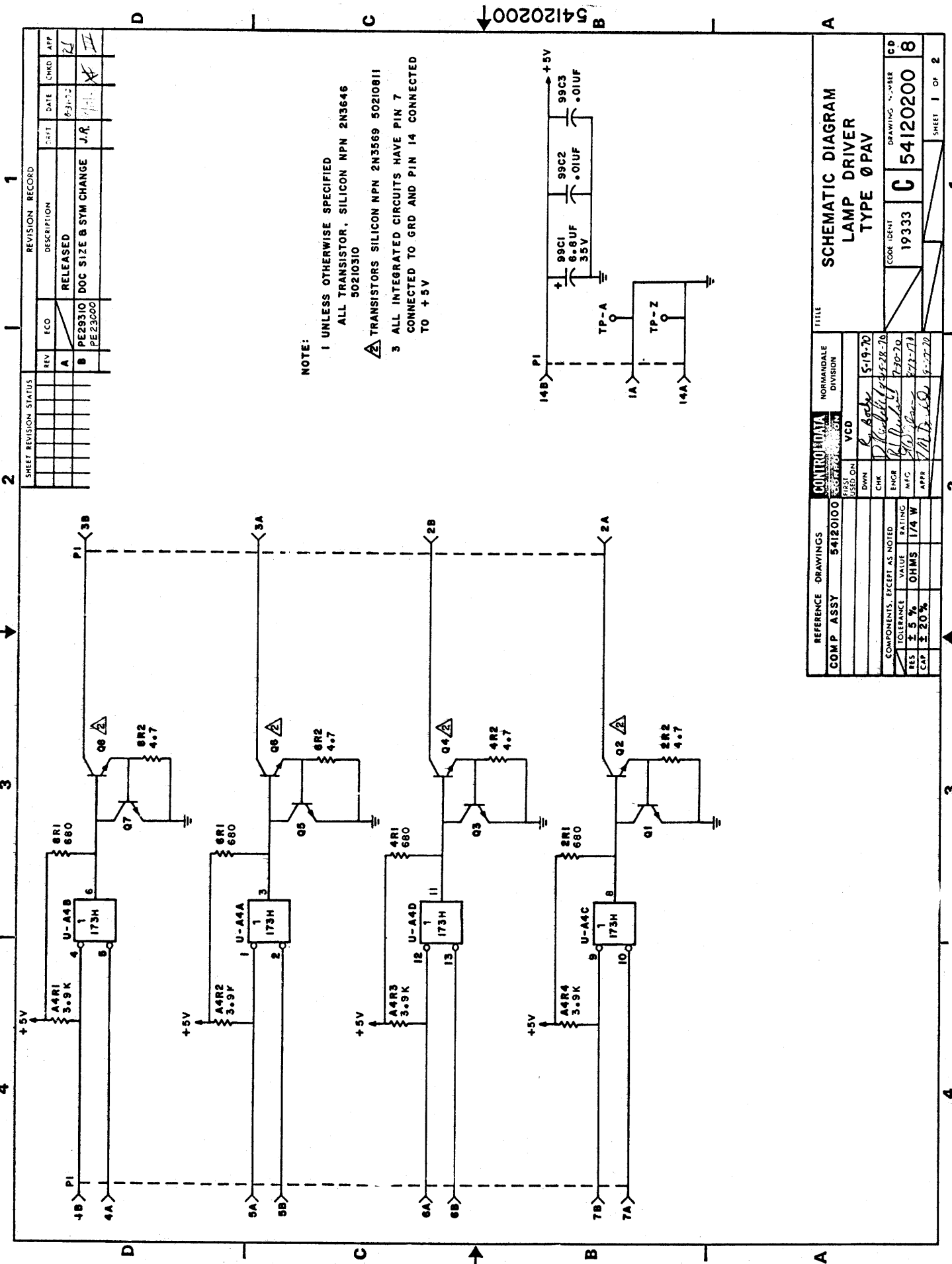

NOTE:
 1 UNLESS OTHERWISE SPECIFIED
 ALL TRANSISTOR, SILICON NPN 2N3646
 50210310
 2 TRANSISTORS SILICON NPN 2N3569 50210811
 3 ALL INTEGRATED CIRCUITS HAVE PIN 7
 CONNECTED TO GRD AND PIN 14 CONNECTED
 TO +5V

SHEET REVISION STATUS		REVISION RECORD			
REV	ECO	DESCRIPTION	DATE	CHKD	APP
A		RELEASED	5/19/70		
B		PE29310 DOC SIZE & SYM CHANGE	J.R.		
		PE23200			

REFERENCE DRAWINGS		CONTROL DATA		NORMAN DALE DIVISION		TITLE	
COMP ASSY	54120100	FIRST USED	DATE	BY	DATE	CODE IDENT	DRAWING NUMBER
		5/19/70	5-28-70	J.R.	5-28-70	19333	54120200
		CHK	ENGR	APP			
COMPONENTS, EXCEPT AS NOTED		TOLERANCE		RATING		DRAWING NUMBER	
RES ± 5%		OHMS 1/4 W				54120200	
CAP ± 20%						8	

SCHEMATIC DIAGRAM
 LAMP DRIVER
 TYPE 0PAV

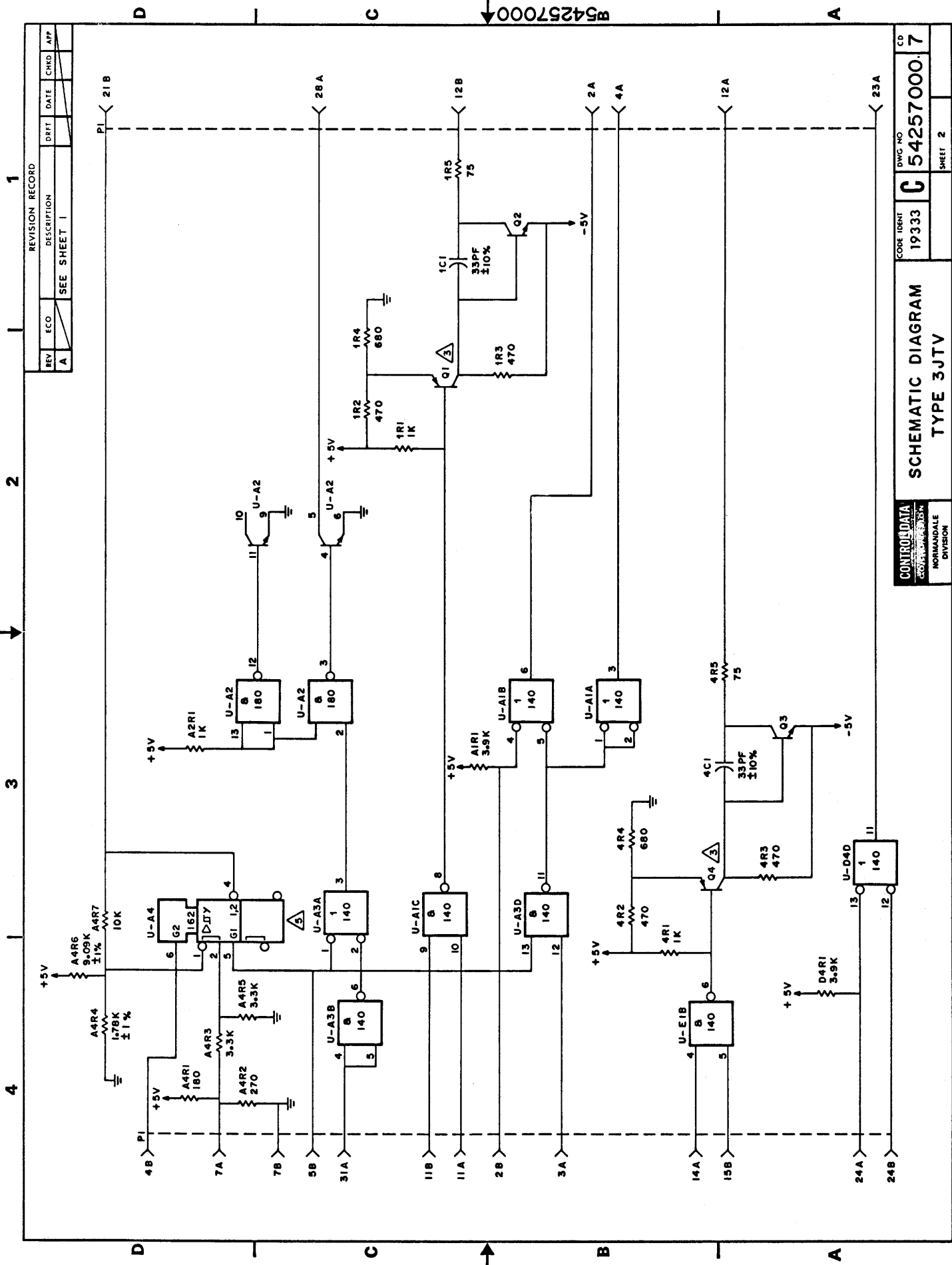

REV	ECO	DESCRIPTION	DRFT	DATE	CHNG	APP
A		SEE SHEET 1				

CONTROL DATA CORPORATION
NORMANVILLE DIVISION

SCHEMATIC DIAGRAM
TYPE 3JTV

CODE IDENT 1933

DWG NO C 54257000

SHEET 2

B54257000

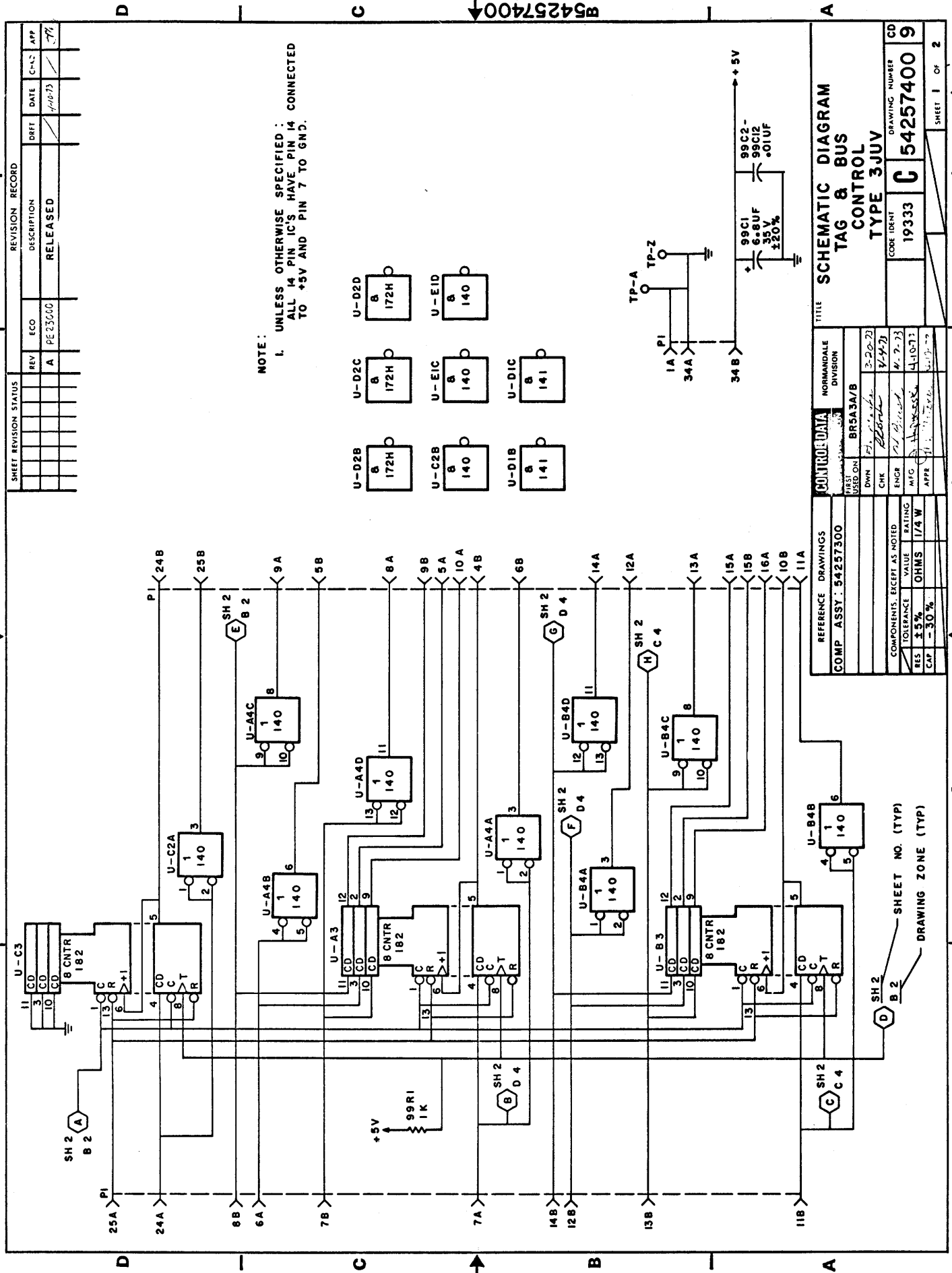

NOTE:
 1. UNLESS OTHERWISE SPECIFIED:
 ALL 14 PIN IC'S HAVE PIN 14 CONNECTED
 TO +5V AND PIN 7 TO GND.

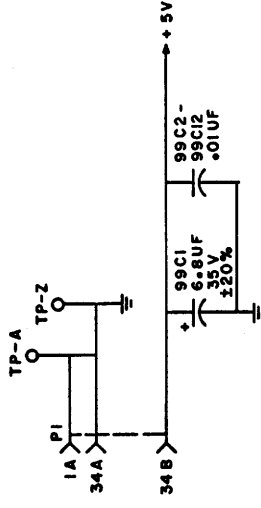
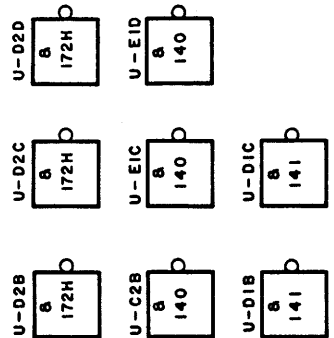

SHEET REVISION STATUS		REVISION RECORD	
REV	ECO	DESCRIPTION	DATE
A	PE23000	RELEASED	7/10/73

COMP. ASSY: 54257300	REFERENCE DRAWINGS	CONTROL DATA	NORMANDEALE DIVISION
U-C3	U-A3	U-A4A	U-A4B
U-A4C	U-A4D	U-B3	U-B4A
U-B4B	U-B4C	U-B4D	U-C2A
U-C2B	U-C2C	U-C2D	U-D1B
U-D1C	U-D1D	U-E1B	U-E1C
U-E1D	U-E1E		

TITLE	SCHEMATIC DIAGRAM TAG & BUS CONTROL TYPE 3JUV		
CODE IDENT	19333	DRAWING NUMBER	54257400
CD	9	SHEET 1 OF	2

SHEET NO. (TYP)
 DRAWING ZONE (TYP)

854257400

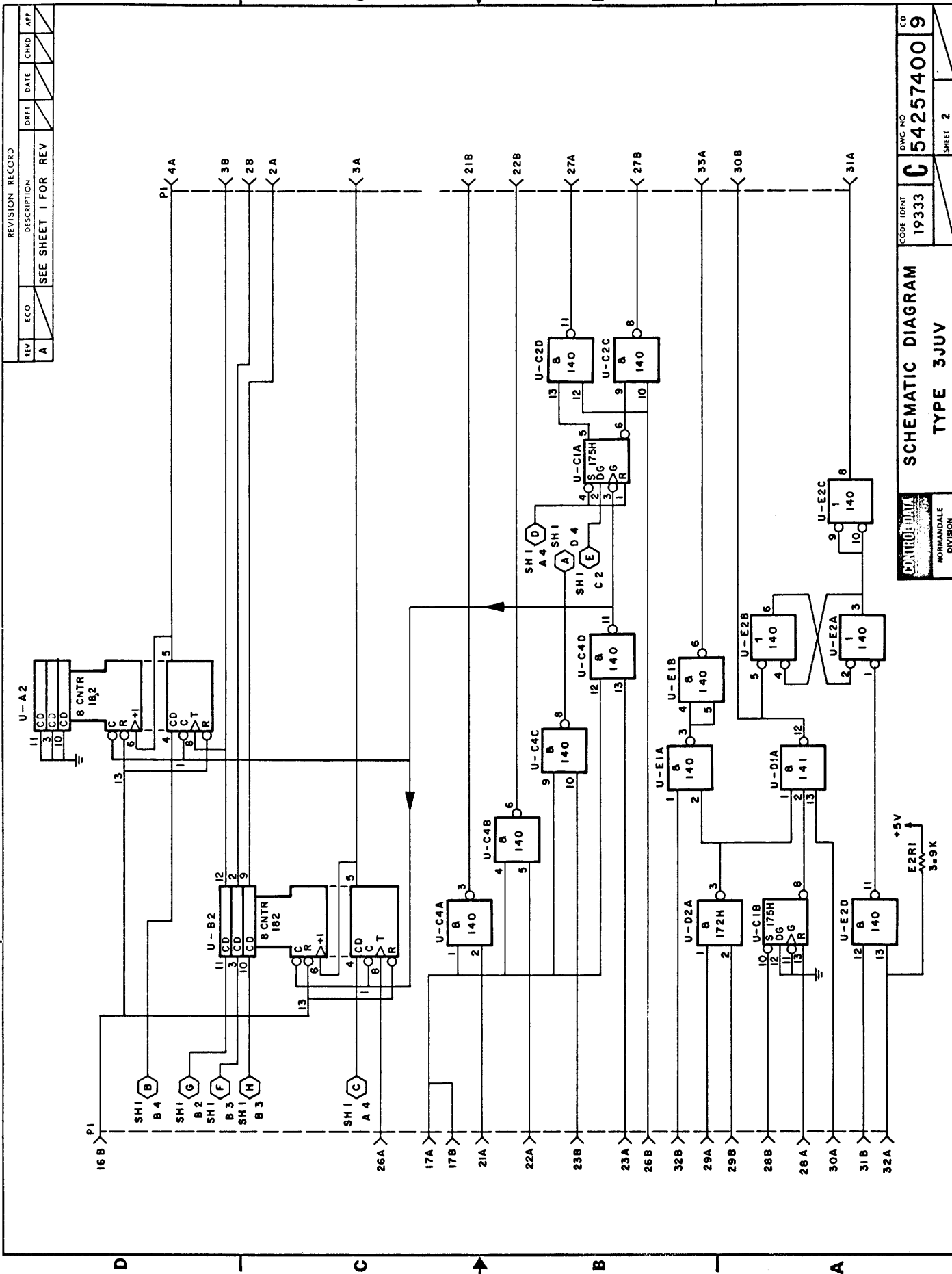

CD
 DWG NO C 54257400 9
 CODE IDENT 19333
SCHEMATIC DIAGRAM
 TYPE 3JUUV
 CONTROL DATA
 NORMANDALE DIVISION
 SHEET 2

B54257400

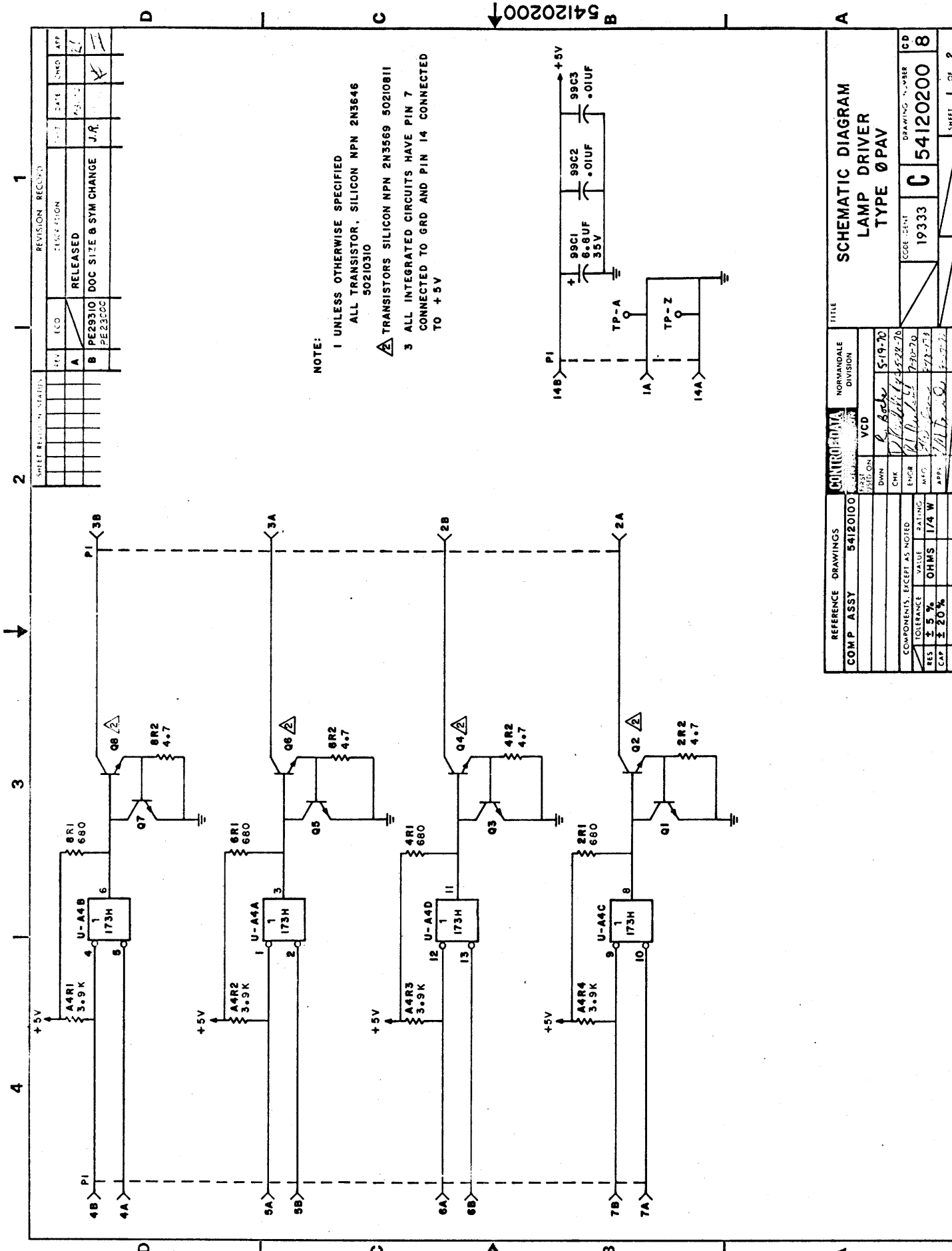

NOTE:
 1 UNLESS OTHERWISE SPECIFIED
 ALL TRANSISTOR, SILICON NPN 2N3646
 50210310
 2 TRANSISTORS SILICON NPN 2N3569 50210811
 3 ALL INTEGRATED CIRCUITS HAVE PIN 7
 CONNECTED TO GRD AND PIN 14 CONNECTED
 TO +5V

REFERENCE DRAWINGS		CONTROL DATA		NORMANDALE DIVISION		TITLE	
COMP ASSY	54120100	REV	ECO	DATE	CHKD	APP	SCHEMATIC DIAGRAM LAMP DRIVER TYPE ØPAV
COMPONENTS, EXCEPT AS NOTED		VCD		DWN		DRAWING NUMBER	
TOLERANCE	± 5%	ENGR	VAL	DATE	19333	C 54120200 8	
RES	± 20%	APP	VAL	DATE	CODE IDENT		
CAP	± 20%	APP		DATE		DRAWING NUMBER	
CAP		APP		DATE		DRAWING NUMBER	

4 3 2 1

D C B A

PI 3B 3A 2B 2A 4B 4A 5A 5B 6A 6B 7A 7B

54120200



CONTROL DATA
CORPORATION
NORMANDALE
DIVISION

SCHEMATIC DIAGRAM
LAMP DRIVER
TYPE ØPAV

CODE DENT 19333
DWG NO C 54120200
SHEET 2

CD 8

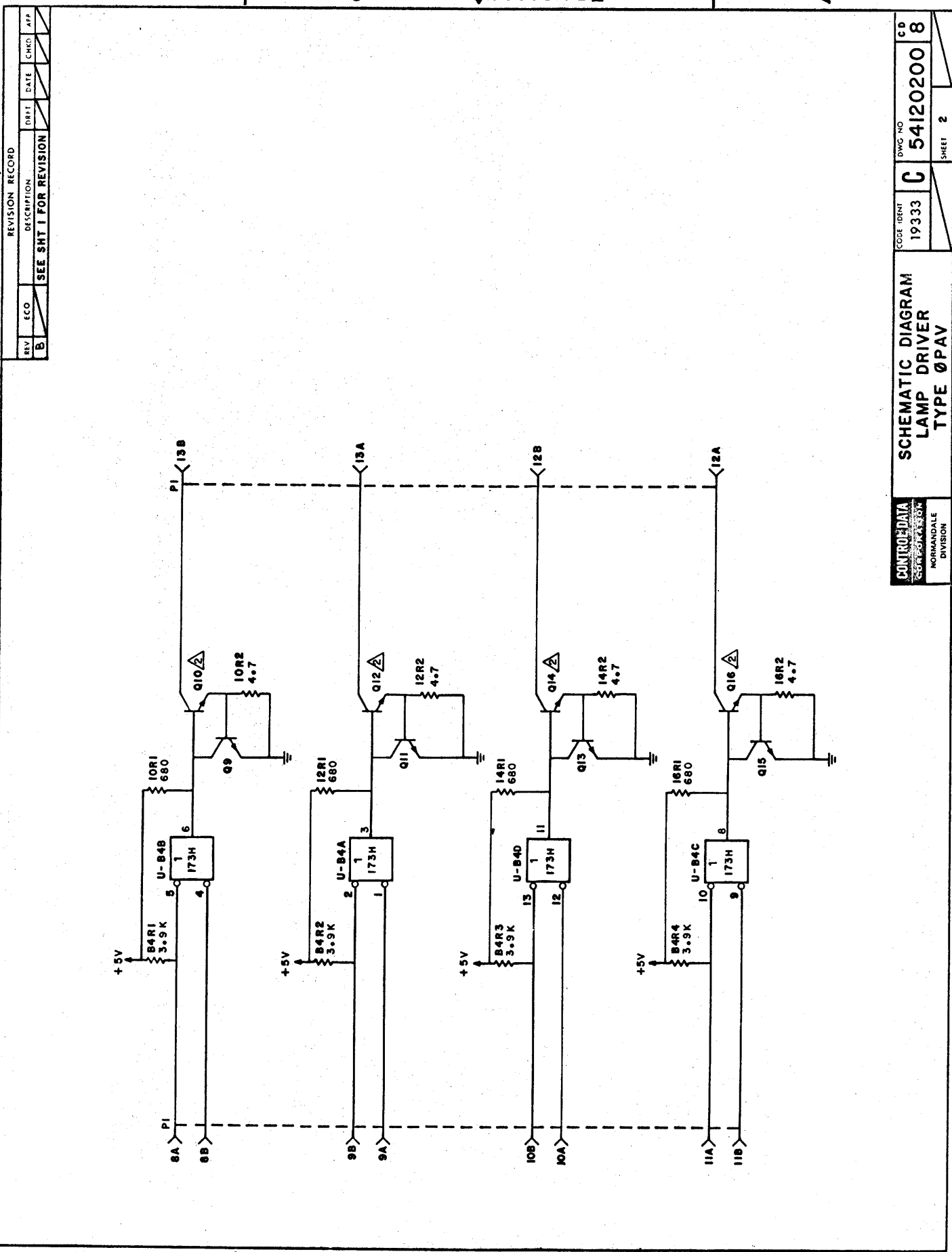

REV	ECO	DESCRIPTION	DRAW	DATE	CHKD	APP
B		SEE SHT 1 FOR REVISION				

B 54120200 ↓

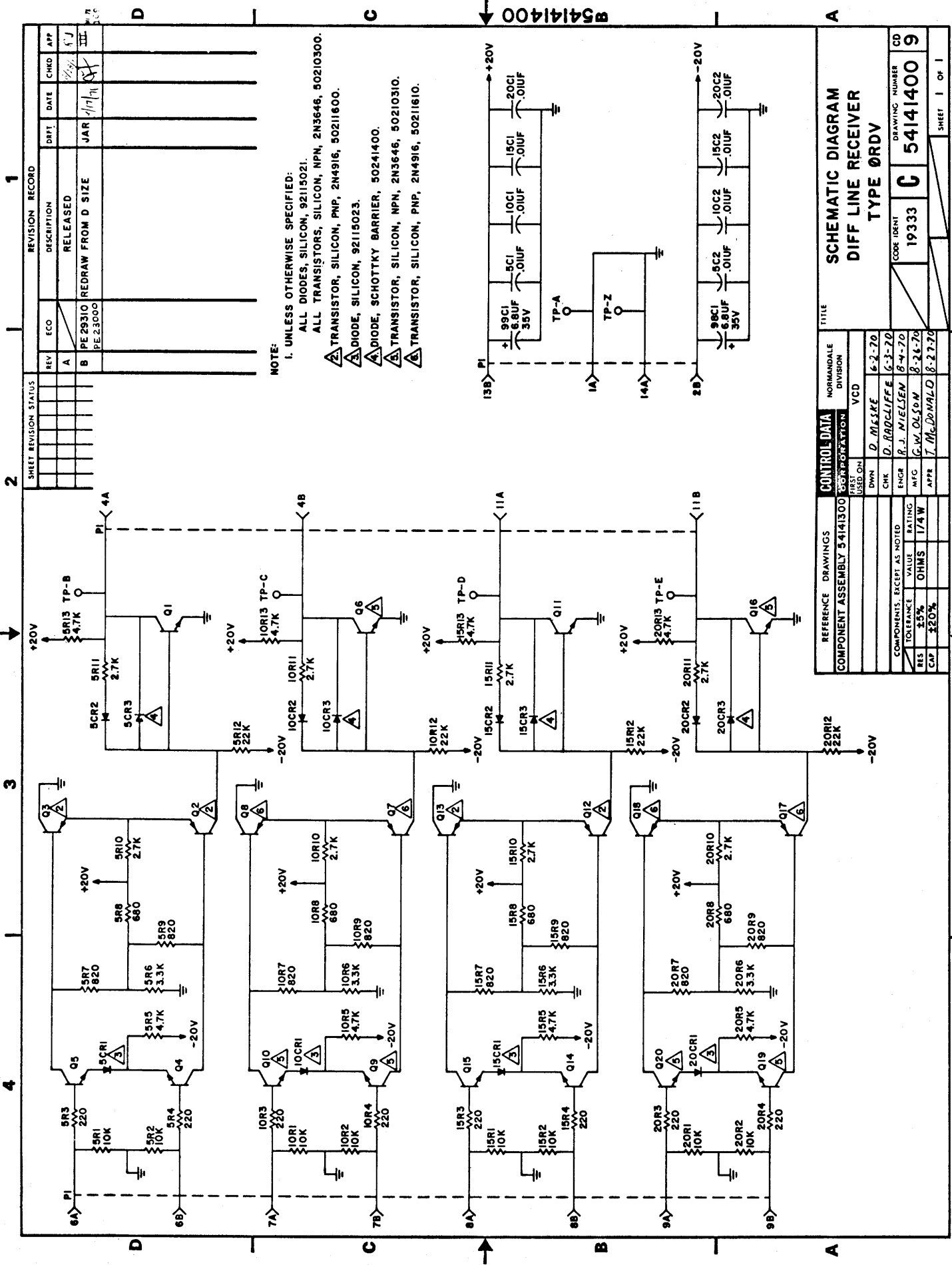

REV	ECO	DESCRIPTION	DATE	CHKD	APP
A		RELEASED			
B	PE29310	REDRAW FROM D SIZE	JAR 1/17/71		
	PE23000				

NOTE:
 1. UNLESS OTHERWISE SPECIFIED:
 ALL DIODES, SILICON, 92115021.
 ALL TRANSISTORS, SILICON, NPN, 2N3646, 50210300.
 △ TRANSISTOR, SILICON, PNP, 2N4916, 50211800.
 △ DIODE, SILICON, 92115023.
 △ DIODE, SCHOTTKY BARRIER, 50241400.
 △ TRANSISTOR, SILICON, NPN, 2N3646, 50210310.
 △ TRANSISTOR, SILICON, PNP, 2N4916, 50211610.

REFERENCE DRAWINGS		CONTROL DATA		TITLE	
COMPONENT ASSEMBLY 54141300		NORMANDALE DIVISION		SCHEMATIC DIAGRAM	
FIRST USED ON		VCD		DIFF LINE RECEIVER	
DWN	D. MCELVE	6-2-70		TYPE ØRD	
CHK	D. MADLIFE	6-3-70		DRAWING NUMBER	
ENGR	B. J. NIELSEN	8-4-70		19333	
MFG	C. W. OLSON	8-24-70		COORDINATE	
TOLERANCE	VALUE	RATING		54141400	
RES	±5%	OHMS	1/4 W	CD	
CAP	±20%			9	
				SHEET 1 OF 1	

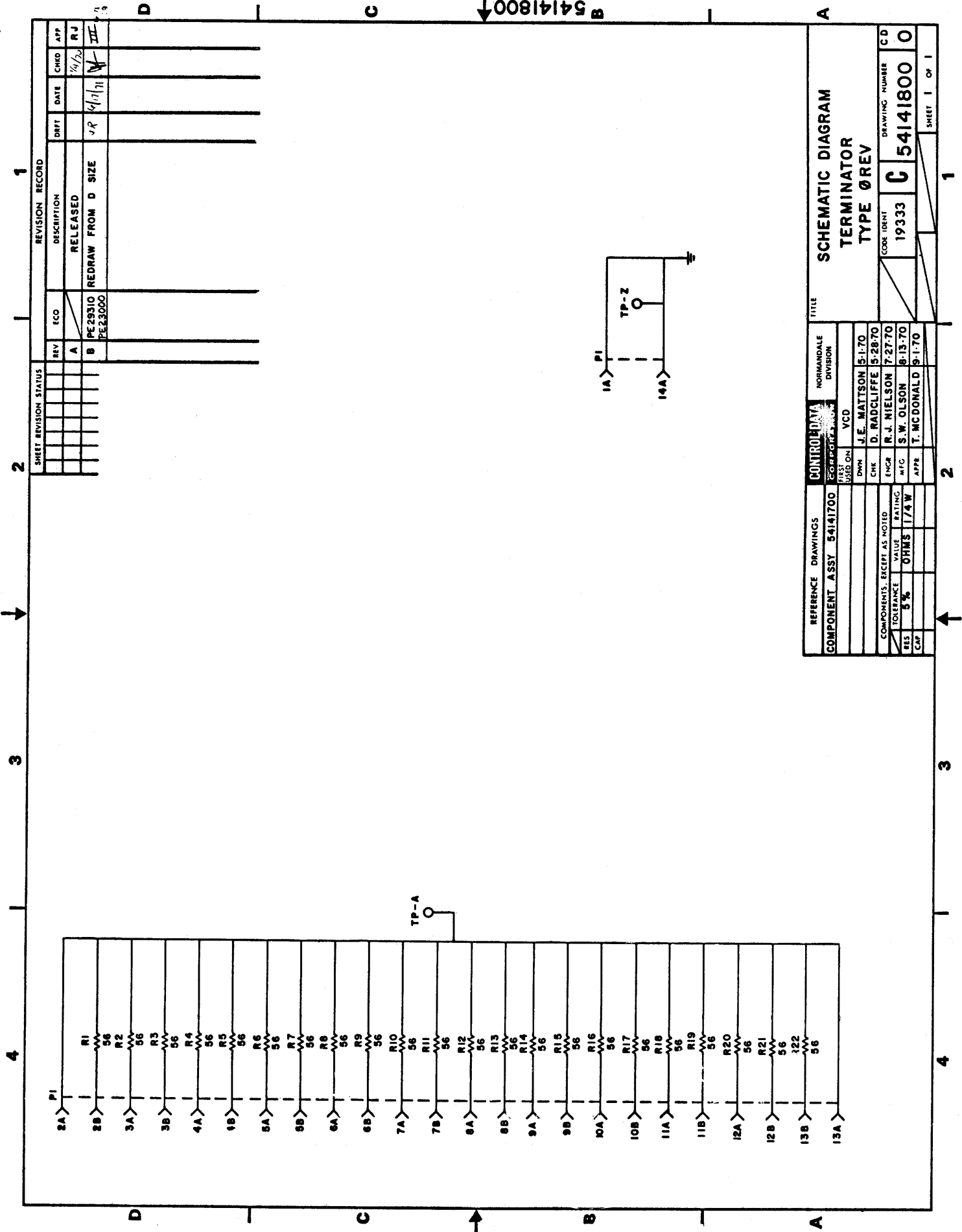

REFERENCE DRAWINGS		CONTROL DATA CORPORATION		NORMANDALE DIVISION	
COMPONENT ASSY 54141700		FIRST USED ON		YCD	
		DWN		J.E. MATISON 5-1-70	
		CHK		D. RADCLIFFE 5-28-70	
		ENGR		R.J. NIELSON 7-27-70	
		MFC		S.W. OLSON 8-13-70	
		APPR		T. McDONALD 9-1-70	
COMPONENTS EXCEPT AS NOTED		DRAWING NUMBER			
TOLERANCE VALUE RATING		19333		C 54141800	
RES 5% OHMS 1/4W		CORE IDENT		DRAWING NUMBER	
CAP				CD	
				0	

SCHEMATIC DIAGRAM
 TERMINATOR
 TYPE ØREV

TITLE

19333

54141800

SHEET 1 OF 1

1

2

3

4

D

C

B

A

4

3

2

1

54141800

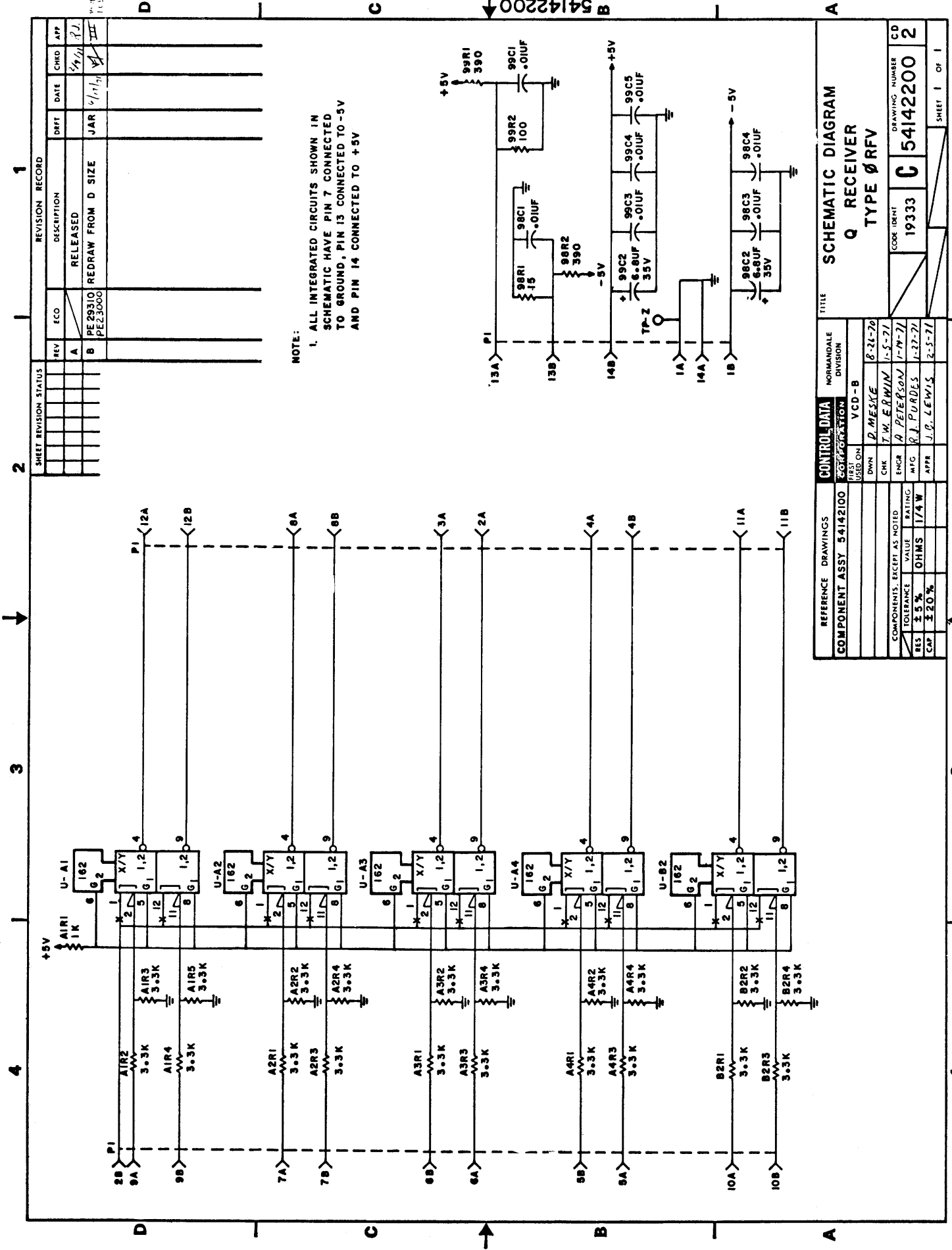

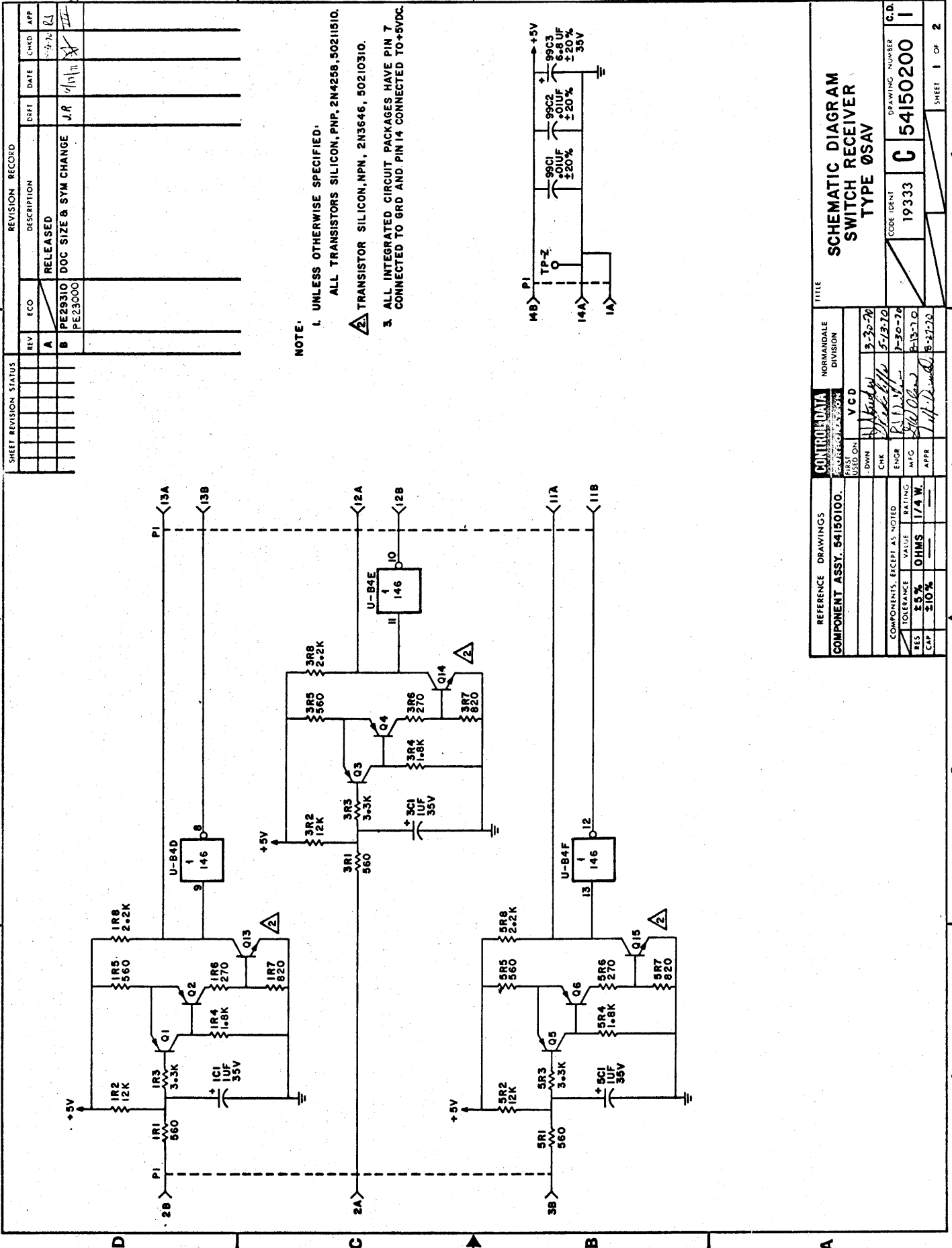

NOTE:
 1. UNLESS OTHERWISE SPECIFIED:
 ALL TRANSISTORS SILICON, PNP, 2N4258, 50211510.
 2. TRANSISTOR SILICON, NPN, 2N3646, 50210310.
 3. ALL INTEGRATED CIRCUIT PACKAGES HAVE PIN 7
 CONNECTED TO GRD AND PIN 14 CONNECTED TO +5VDC.

SHEET REVISION STATUS		REVISION RECORD			
REV	ECO	DESCRIPTION	DATE	CHKD	APP
A		RELEASED	7/1/75	RL	
B		PE29310 DOC SIZE & SYM CHANGE	J.R.		
		PE23000			

REFERENCE DRAWINGS		CONTROL DATA		NORMANDALE DIVISION	
COMPONENT ASSY. 54150100.		ELECTRONIC		DIVISION	
FIRST USED ON:		DOWN	3-30-70		
CHK		ENGR	5-13-70		
ENGR		MFG	7-20-70		
APPR		APPR	8-13-70		
			8-27-70		
COMPONENTS EXCEPT AS NOTED		TITLE			
TOLERANCE	VALUE	SCHEMATIC DIAGRAM			
RES	5%	SWITCH RECEIVER			
CAP	±10%	TYPE ØSAV			
		CODE IDENT	DRAWING NUMBER		
		19333	C 54150200		
		SHEET 1 OF 2			

REV	ECO	DESCRIPTION	DATE	CHKD	APP
B		SEE SHEET 1			

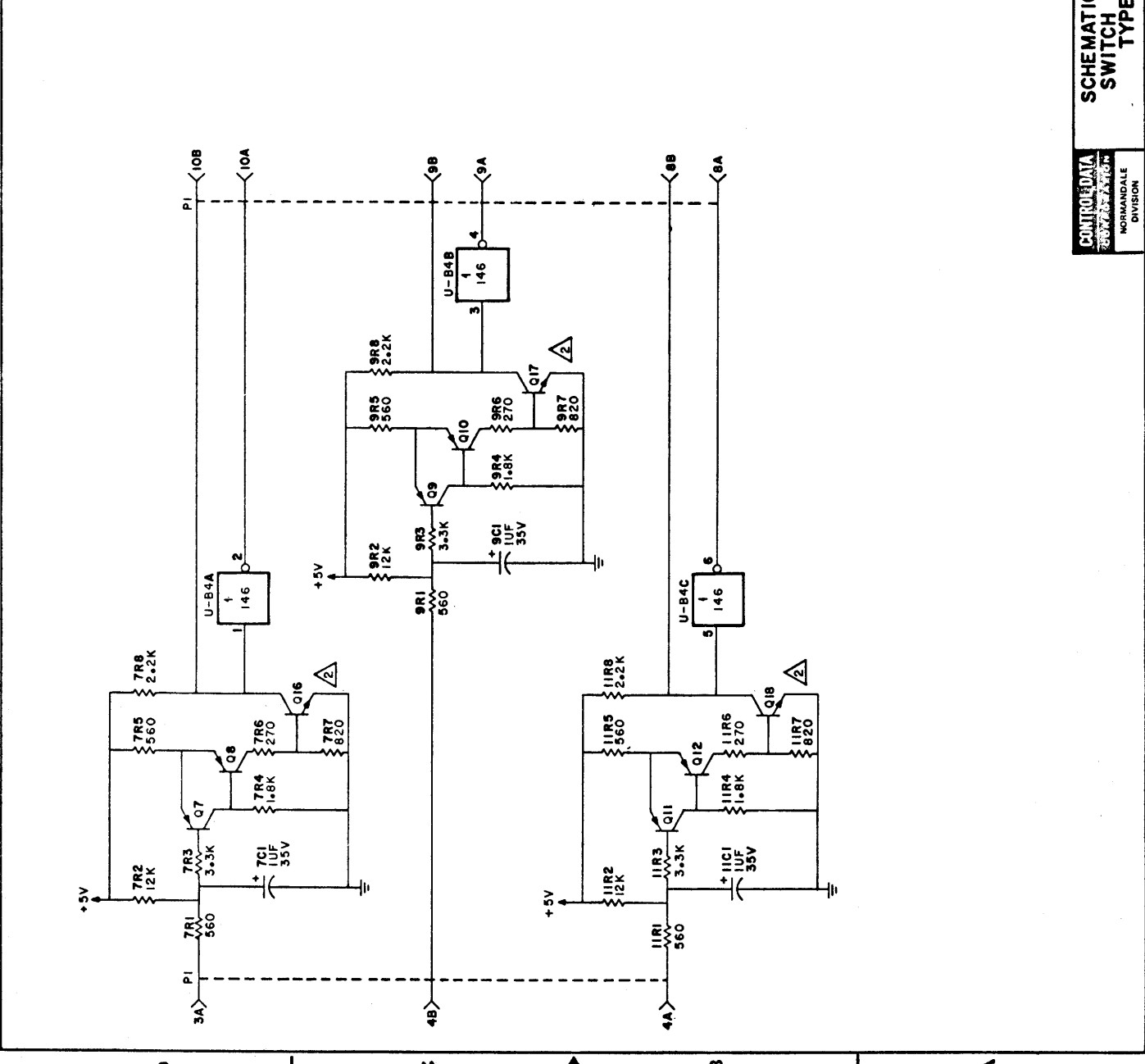

D I C B A

B 54150200

CONTROL DATA CORPORATION
 NORMANVILLE DIVISION

SCHEMATIC DIAGRAM
SWITCH RECEIVER
TYPE ØSAV

CODE IDENT 19333
 DWG NO C 54150200
 SHEET 2

C.D. 1

1 2 3 4

1 2 3 4

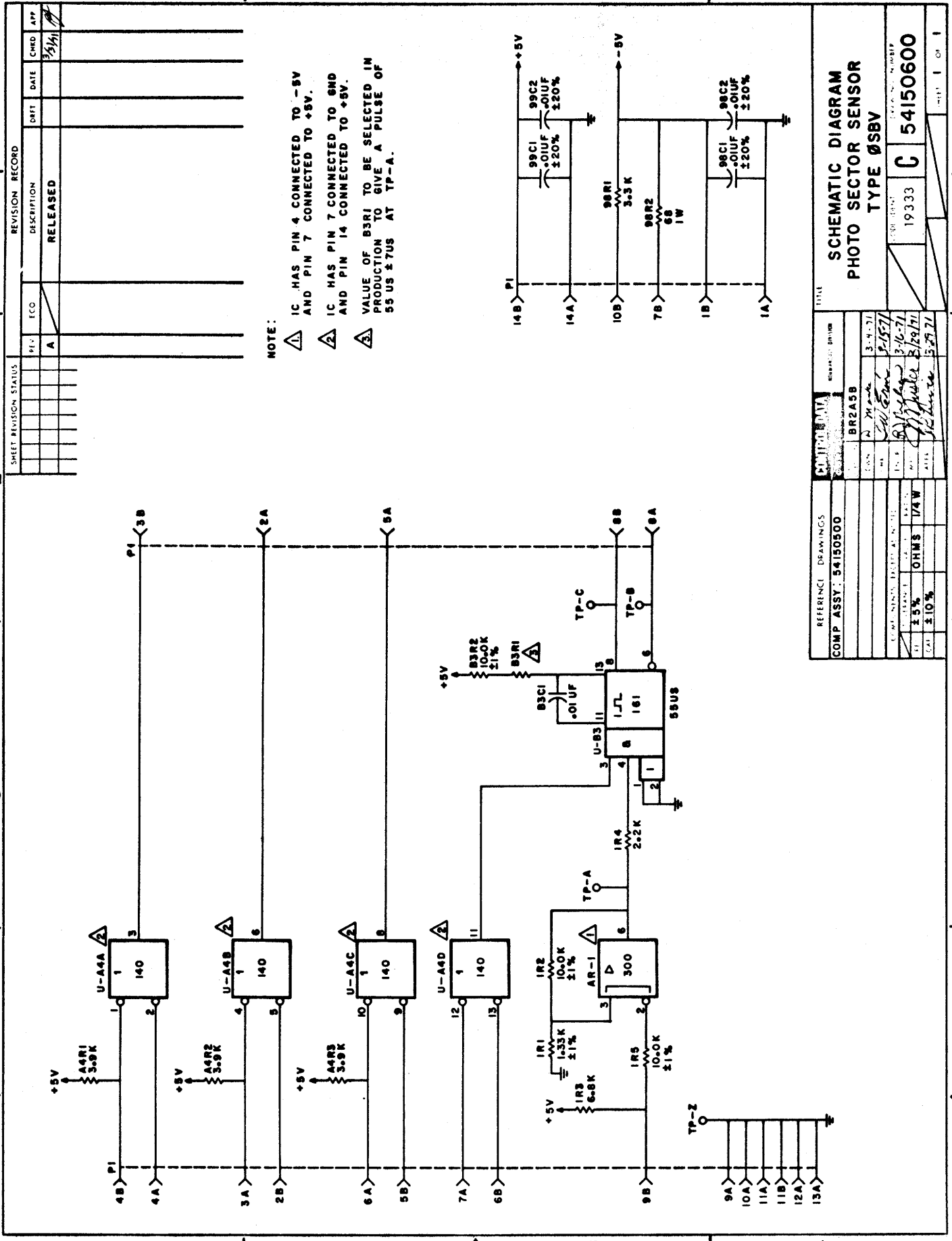

NOTE:
 ⚠ IC HAS PIN 4 CONNECTED TO -8V AND PIN 7 CONNECTED TO +8V.
 ⚠ IC HAS PIN 7 CONNECTED TO GND AND PIN 14 CONNECTED TO +8V.
 ⚠ VALUE OF B3R1 TO BE SELECTED IN PRODUCTION TO GIVE A PULSE OF 55 US ± 70S AT TP-A.

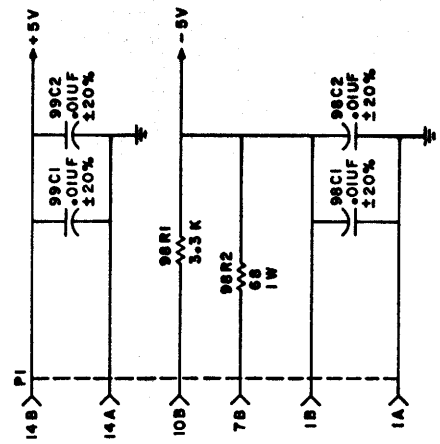

REVISION RECORD

REV.	ECO	DATE	CHKD	APP.
A				

DESCRIPTION: RELEASED

REFERENCE DRAWINGS
 COMP ASSY: 54150500

COMPONENTS LIST

QTY	DESCRIPTION	REF. DESIG.	VAL.	UNIT
1	OHMS	1/4W		
1	OHMS	1/4W		
1	OHMS	1/4W		

DATE: 3/27/71
 BY: [Signature]
 CHECKED: [Signature]

SCHEMATIC DIAGRAM
 PHOTO SECTOR SENSOR
 TYPE ØSBV

19333 C 54150600

B54150600



SHEET REVISION STATUS		REVISION RECORD			
REV	ECO	DESCRIPTION	DRFT	DATE	CHKD APP
A		RELEASED			
B	PE2310 PE2300	REDRAWN FROM D SIZE	AS	6/18/71	W/III

CONTROL DATA	NORMANDALE DIVISION	
REFERENCE DRAWINGS	COMPONENT ASSY 54161301	
USED ON	VCD -200	
OWN	D.C. TITTLE	1-22-71
CHK	R. H. ...	1-22-71
ENGR	Paul ...	1-22-71
MFG	P.T. ...	1-22-71
APPR	P.B. ...	1-27-71

TITLE		SCHEMATIC DIAGRAM
NORMANDALE DIVISION		LINE TRANSMITTER
DRAWING NUMBER		54161401 2
CODE 1081	19333	C
SHEET 1 OF 1		

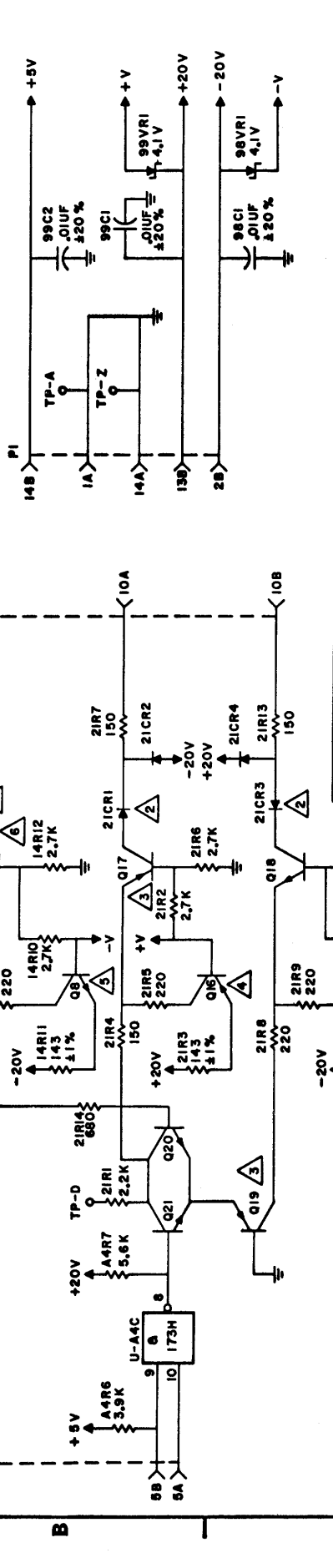

- NOTE:
- UNLESS OTHERWISE SPECIFIED:
 ALL DIODES, SILICON, 92115021
 ALL TRANSISTORS, SILICON, NPN, 2N3646, 50210300
 - DIODE, GERMANIUM, 11801200
 - TRANSISTOR, SILICON, PNP, 2N4258, 50211500
 - TRANSISTOR, SILICON, PNP, 2N2904, 51003108
 - TRANSISTOR, SILICON, NPN, 2N2218, 50210101
 - TRANSISTOR, SILICON, NPN, 2N3646, 50210310
 - TRANSISTOR, SILICON, PNP, 2N4258, 50211510
 - +V IS +16VDC NOMINAL. -V IS -16VDC NOMINAL.
 - ALL INTEGRATED CIRCUIT PACKAGES HAVE PIN 7 CONNECTED TO GRD AND PIN 14 CONNECTED TO +5VDC

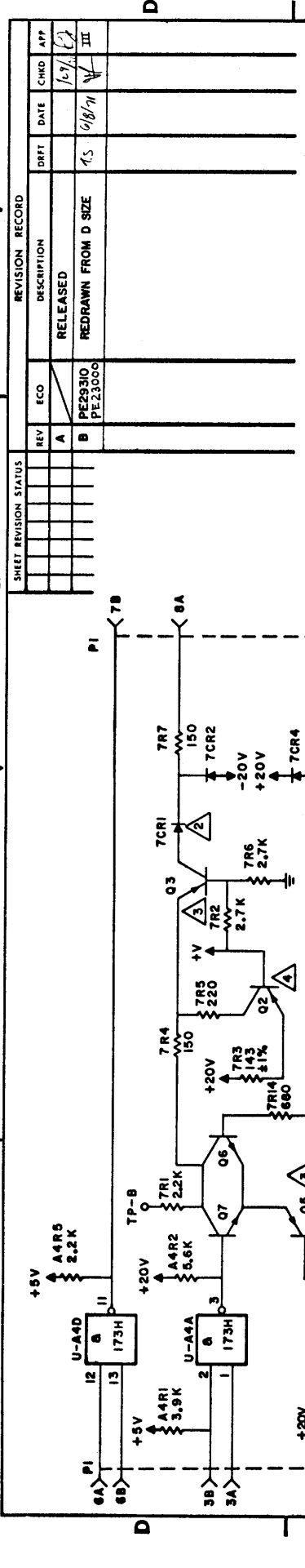

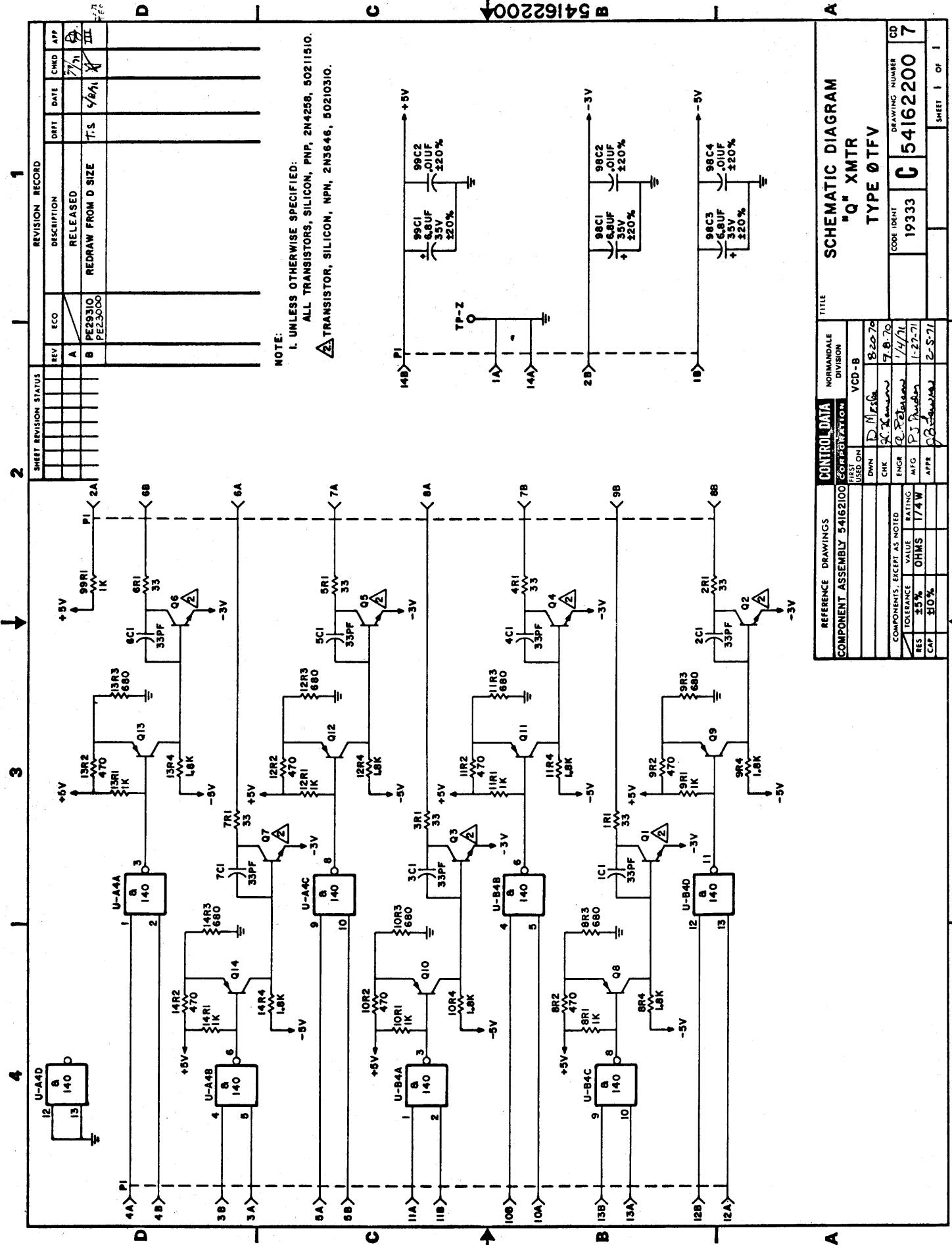

NOTE:
 1. UNLESS OTHERWISE SPECIFIED:
 ALL TRANSISTORS, SILICON, PNP, 2N4258, 50211510.
 2. TRANSISTOR, SILICON, NPN, 2N3646, 50210310.

SHEET REVISION STATUS		REVISION RECORD			
REV	ECO	DESCRIPTION	DATE	CHKD	APP
A		RELEASED	7/5		
B		REDRAW FROM D SIZE	4/6/71		

REFERENCE DRAWINGS		CONTROL DATA		TITLE	
COMPONENT ASSEMBLY	54162200	FIRST USED ON	CORPORATION	NORMANDALE DIVISION	VCD-B
COMPONENTS EXCEPT AS NOTED		CHK	D. M. [Signature]	DWN	8-20-70
TOLERANCE	VALUE	ENGR	[Signature]		7-8-70
RES	5%	MFG	P. J. [Signature]		1-14-71
CAP	50%	APPR	[Signature]		1-27-71
					2-5-71

SCHEMATIC DIAGRAM		DRAWING NUMBER	
"Q" XMTR	TYPE 0TFV	19333	54162200
		CODE IDENT	DRAWING NUMBER
			CD
			7
		SHEET 1 OF 1	

B 54162200A

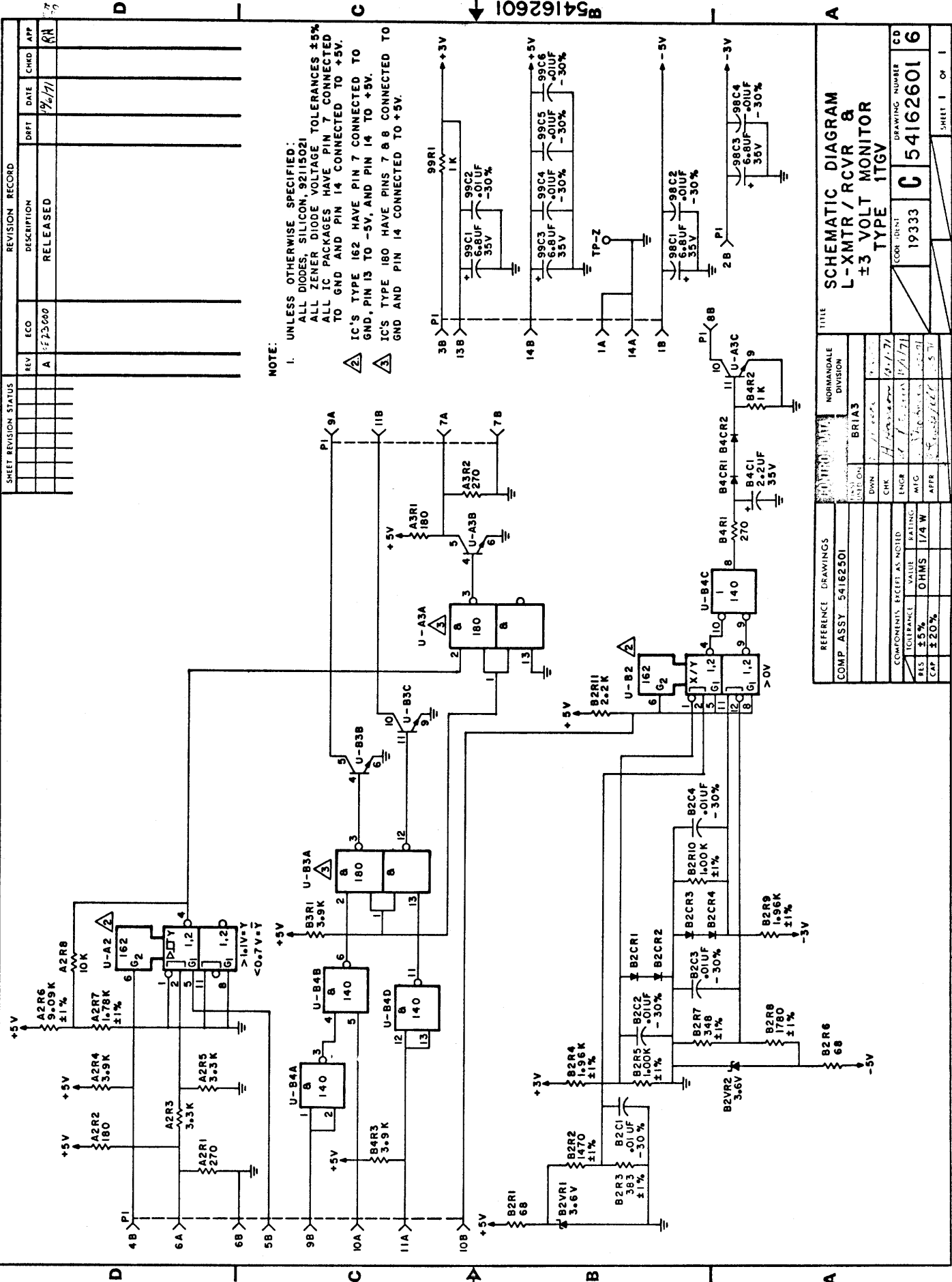

NOTE:
 1. UNLESS OTHERWISE SPECIFIED:
 ALL DIODES, SILICON, 92115021
 ALL ZENER DIODE VOLTAGE TOLERANCES $\pm 5\%$
 ALL IC PACKAGES HAVE PIN 7 CONNECTED TO GND AND PIN 14 CONNECTED TO +5V.
 2. IC'S TYPE 162 HAVE PIN 7 CONNECTED TO GND, PIN 13 TO -5V, AND PIN 14 TO +5V.
 3. IC'S TYPE 180 HAVE PINS 7 & 8 CONNECTED TO GND AND PIN 14 CONNECTED TO +5V.

SHEET REVISION STATUS		REVISION RECORD		
REV	ECO	DESCRIPTION	DATE	CHKD APP
A	123000	RELEASED	7/6/71	RM

REFERENCE DRAWINGS		NORMAN DALE DIVISION	
COMP ASSY	54162501	BR1A3	
DESIGN		CHK	8/1/71
ENGR		WFC	5/11/71
RATNG		AFPR	5/7/71
TOLERANCE	VALUE		
RES	$\pm 5\%$		
CAP	$\pm 20\%$		
TITLE			
SCHEMATIC DIAGRAM			
L-XMTR/RCVR & ±3 VOLT MONITOR			
COORDINATE			
19333		DRAWING NUMBER	
C 54162601		CD	
SHEET 1 OF 1		1 VCD	



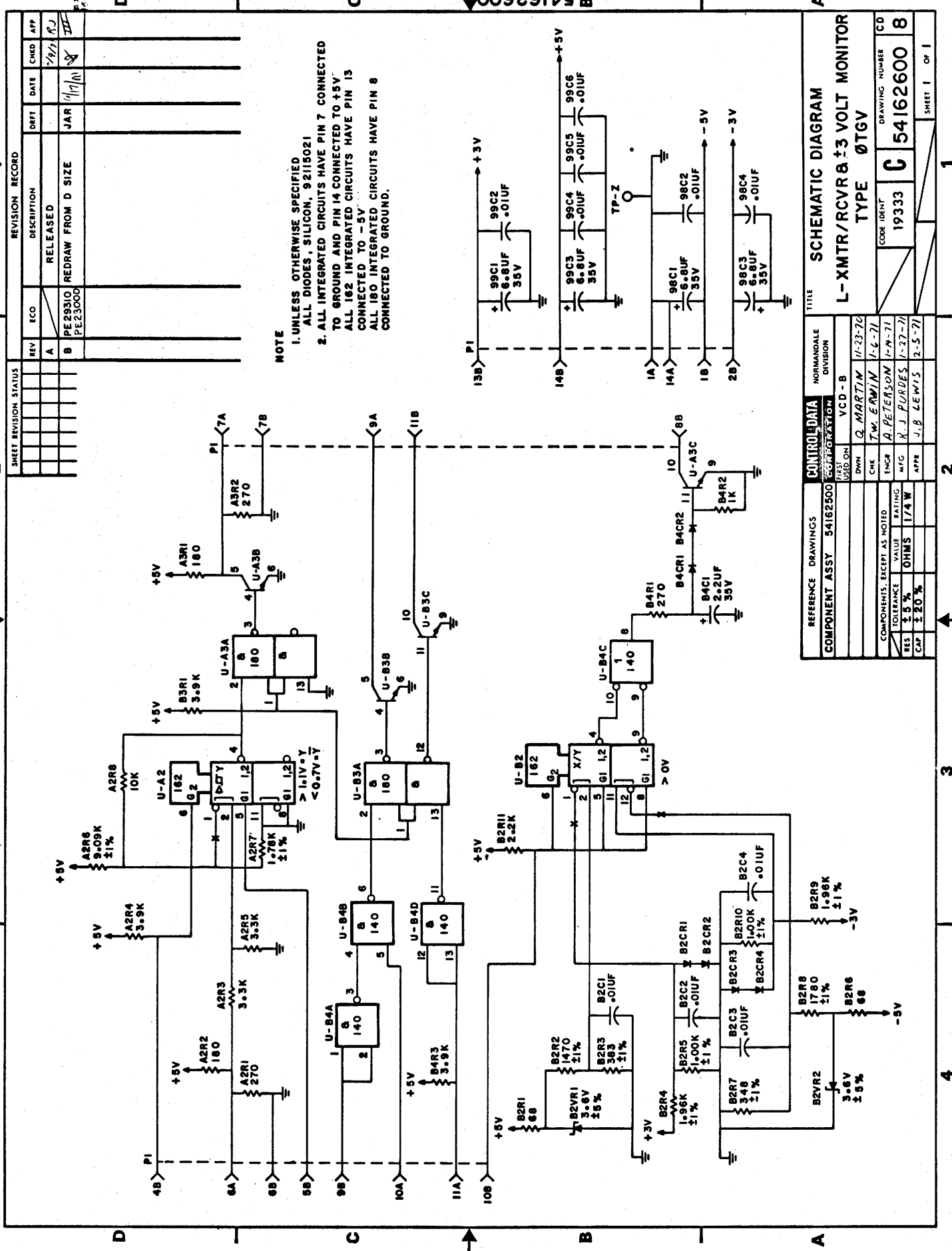

NOTE
 1. UNLESS OTHERWISE SPECIFIED
 ALL DIODES, SILICON, 92115021
 2. ALL INTEGRATED CIRCUITS HAVE PIN 7 CONNECTED
 TO GROUND AND PIN 14 CONNECTED TO +5V
 ALL 162 INTEGRATED CIRCUITS HAVE PIN 13
 CONNECTED TO -5V
 ALL 180 INTEGRATED CIRCUITS HAVE PIN 8
 CONNECTED TO GROUND.

SHEET REVISION STATUS		REVISION RECORD		CHKD	APP
REV	ECO	DESCRIPTION	DATE		
A		RELEASED			
B	PE29310 PE29300	REDRAW FROM D SIZE	JAR 1/17/71		

REFERENCE DRAWINGS	CONTROL DATA	NORMANDE	
COMPONENT ASSY 54162500	54162500	DIVISION	
USED ON	VCD - B		
DWN	Q. MARTIN	11-23-70	
CHK	T.W. EMMIN	1-6-71	
ENGR	A. PETERSON	1-11-71	
APP	J. B. LEWIS	2-5-71	

TITLE		SCHEMATIC DIAGRAM	
L-XMTR/RCVR 3 VOLT MONITOR		TYPE 0TGV	
COOK IDENT	19333	DRAWING NUMBER	54162600
CHECKED		CD	8

1

2

3

4

D

C

B

A

B 54162600

1

2

3

4

SHEET REVISION STATUS		REVISION RECORD			
REV	ECO	DESCRIPTION	DATE	CHKD	APP
A	PE29136	DWG SIMILAR TO B CREATED BY USING MASTER FROM 54170200 TYPE 0UAV	9/21/71	J	NE
B	PE23000				
C	PE29310	REDRAWN FROM D SIZE	7/5/71	J	NE
D	PE29599	Q7 WAS 50210310	8-11-71	K	II

NOTE:
 1. UNLESS OTHERWISE SPECIFIED:
 ALL TRANSISTOR SILICON, NPN, 2N4250, 5021411
 ALL DIODES SILICON, 92115021
 2. TRANSISTOR SILICON, NPN, 2N3546, 50210310
 3. TRANSISTOR SILICON, NPN, 2N3569, 50210811
 4. RECTIFIER, SILICON CONTROL, 93314010
 5. TRANSISTOR, SILICON, NPN, 50210102.

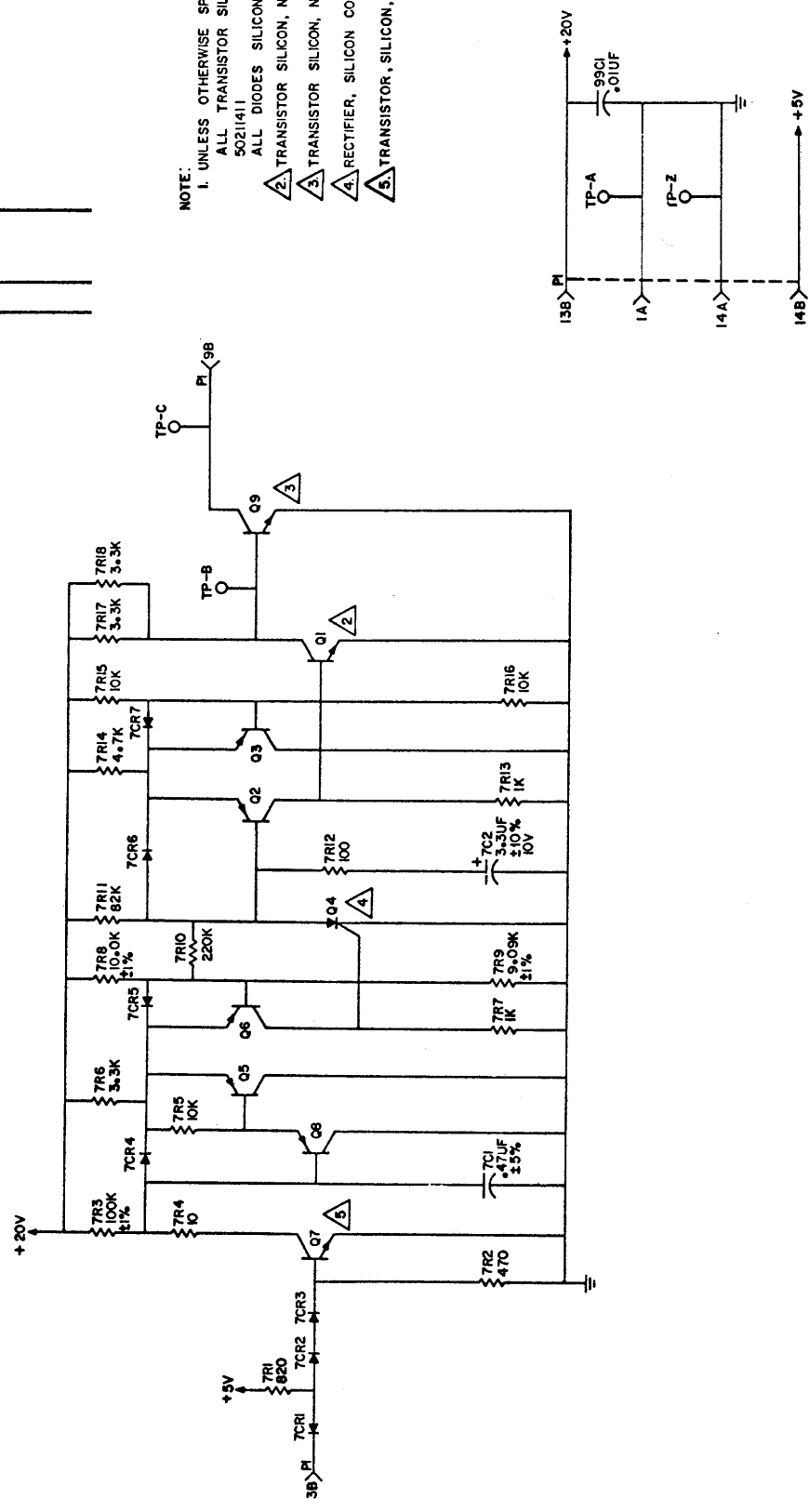

REFERENCE DRAWINGS		TITLE	
COMPONENT ASSY 54170101		SCHEMATIC DIAGRAM	
		SPEED DETECTOR	
		TYPE 1UAV	
VCD		19333	DRAWING NUMBER
DESIGNER		C	54170201
CHECKED			
DATE			
BY			
APPR			
SCALE			
MATERIAL			
QUANTITY			
REMARKS			
SHEET 1 OF 1			

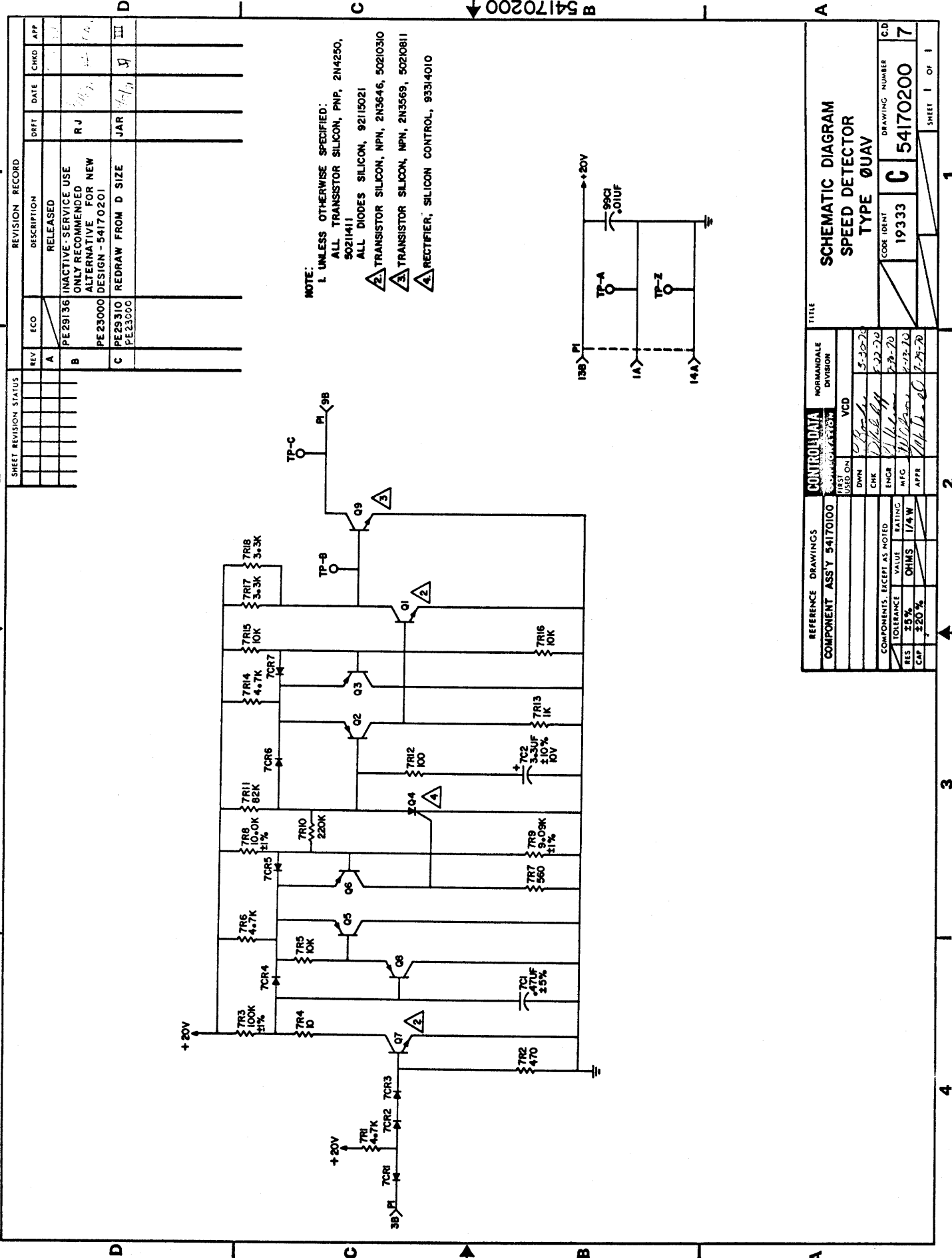

REV	ECO	DESCRIPTION	DRFT	DATE	CHKD	APP
A	PE29136	RELEASED				
B		INACTIVE - SERVICE USE ONLY RECOMMENDED ALTERNATIVE FOR NEW DESIGN - 54170201	RJ			
C	PE29310	REDDRAW FROM D SIZE	JAR	1/17		
D	PE23000					
	PE23000					

NOTE:
 1 UNLESS OTHERWISE SPECIFIED:
 ALL TRANSISTOR SILICON, PNP, 2N4250,
 5021411
 ALL DIODES SILICON, 92115021
 2 TRANSISTOR SILICON, NPN, 2N3646, 50210310
 3 TRANSISTOR SILICON, NPN, 2N3569, 50210811
 4 RECTIFIER, SILICON CONTROL, 93314010

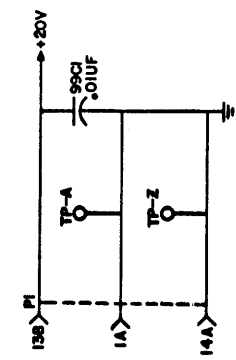

REFERENCE DRAWINGS		CONTROL DATA		NORMAN DALE	
COMPONENT ASSY 54170100		FIRST INFORMATION		DIVISION	
USED ON	VCD	CHK	5-30-70		
ENGR	5-22-70	MTC	5-22-70		
APPR	5-22-70	APPR	5-22-70		
COMPONENTS, EXCEPT AS NOTED		TOLERANCE VALUE		RATING	
RES 5%		OHMS 1/4 W		CAP 320%	

TITLE		DRAWING NUMBER	
SCHEMATIC DIAGRAM		19333	
SPEED DETECTOR		C 54170200	
TYPE 0UAV		7	
SHEET 1 OF 1			

SHEET REVISION STATUS			REVISION RECORD			
REV	ECO	DATE	DESCRIPTION	DFT	CHKD	APP
A		7/23/60	RELEASED		%/7/71	RN

54171400

NOTE:

- 1. UNLESS OTHERWISE SPECIFIED: ALL IC PACKAGES HAVE PIN 7 CONNECTED TO GND AND PIN 14 CONNECTED TO +5V.
- 2. ALL TRANSISTOR, SILICON, NPN, 2N2221, 50210102, ALL DIODE, SILICON, 92115021.
- 3. TRANSISTOR, SILICON, NPN, 2N3568, 50210810.
- 4. VALUE TO BE SELECTED PER ENGINEERING TEST PROCEDURE.
- 5. DELAY TIME FOR REF ONLY.

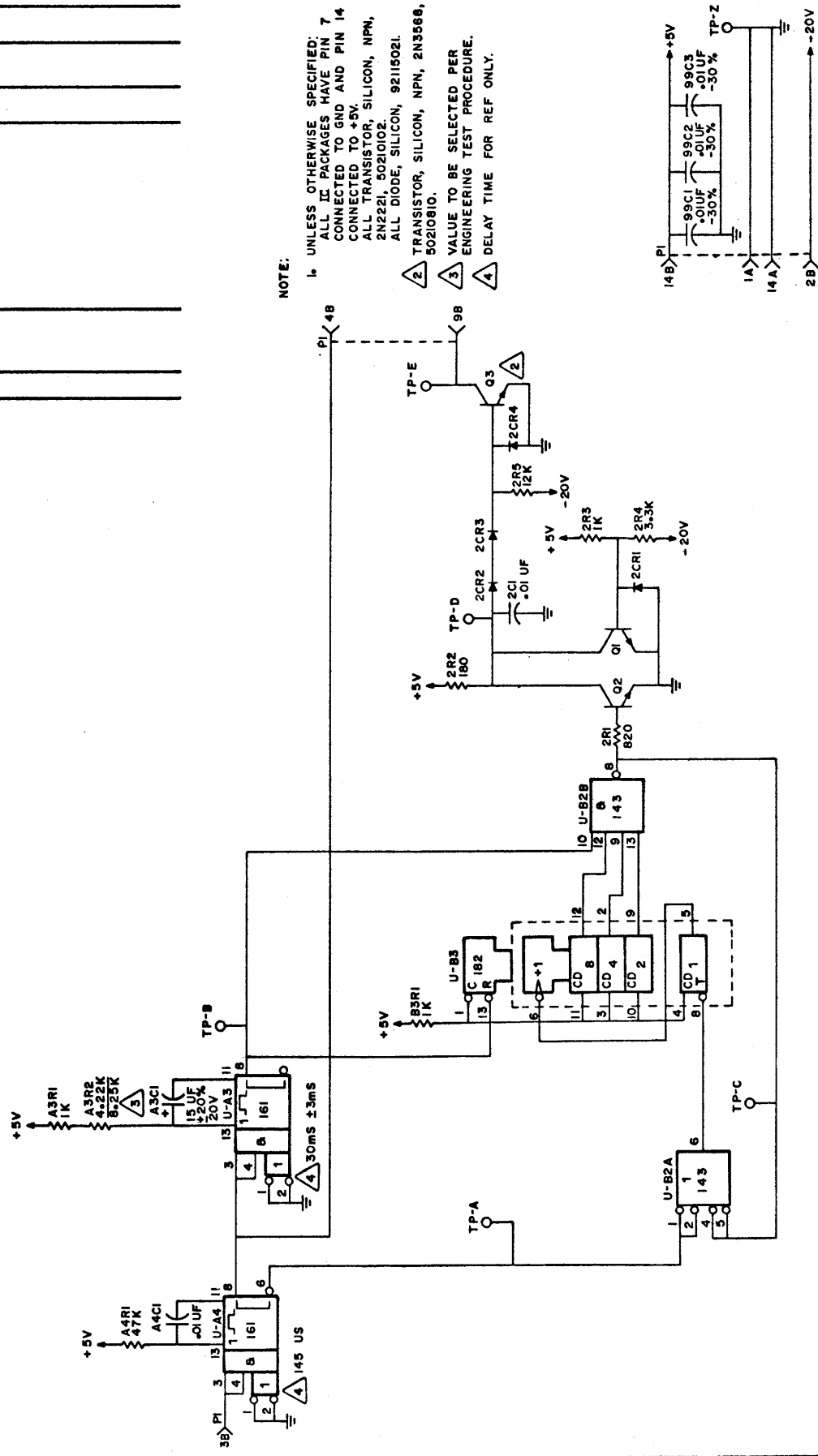

REFERENCE DRAWINGS		ESTABLISH DRAWING	
COMPONENT ASSY 54171300	BR2A5B	DATE	9/1/71
		DESIGNED BY	G. MARTIN
		CHECKED BY	
COMPONENTS BASED AS LISTED			
		DATE	7/27/60
		BY	
		TEST	
		APPR	
TOL	±5%	OHMS	1/4W
VAL	±10%		

SCHEMATIC DIAGRAM			
SPEED DETECTOR			
TYPE 1UDV			
FORM NO.	19333	DRAWING NUMBER	54171400
CD	2		

YCD

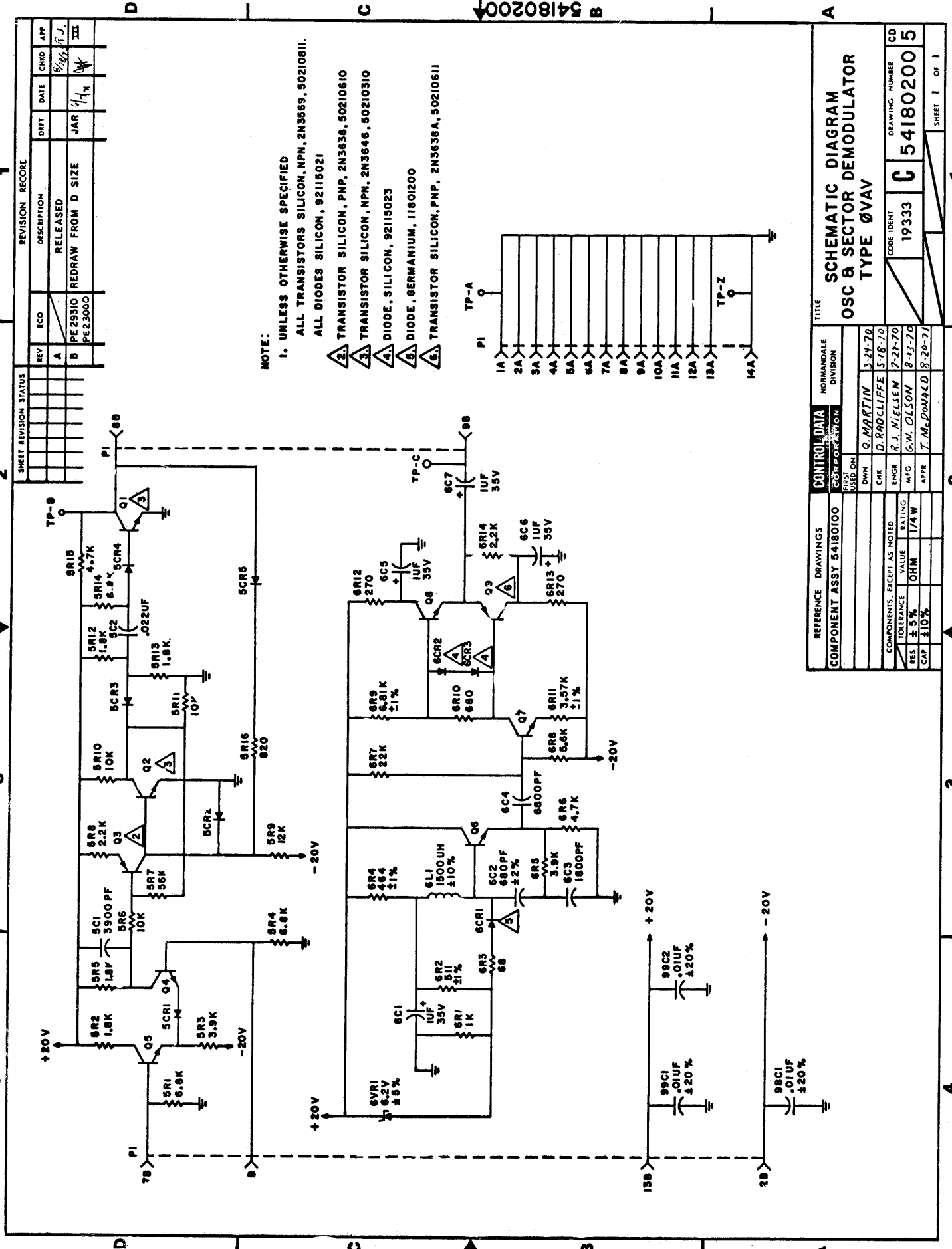

NOTE:

1. UNLESS OTHERWISE SPECIFIED
ALL TRANSISTORS SILICON, NPN, 2N3636, 50210611.
ALL DIODES SILICON, 92115021
2. TRANSISTOR SILICON, PNP, 2N3636, 50210610
3. TRANSISTOR SILICON, NPN, 2N3646, 50210310
4. DIODE, SILICON, 92115023
5. DIODE, GERMANIUM, 11801200
6. TRANSISTOR SILICON, PNP, 2N3638A, 50210611

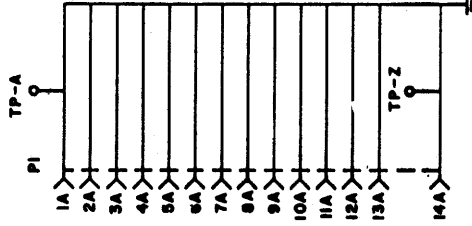

SHEET REVISION STATUS		REVISION RECORD				
REV	ECO	DESCRIPTION	DRFT	DATE	CHKD	APP
A		RELEASED				
B		PE29310 REDRAW FROM D SIZE	JAR	7/47		
PE23000						

REFERENCE DRAWINGS		CONTROL DATA CORPORATION		NORMANDALE DIVISION	
COMPONENT ASSY	54180100	FIRST USEL ON	CHK	DWN	DATE
				Q. MARTIN	3-24-70
				D. RADCLIFFE	5-18-70
				R. J. NIELSEN	7-27-70
				G. W. OLSON	8-17-70
				T. M. DONALD	8-20-71

TITLE		DRAWING NUMBER	
SCHEMATIC DIAGRAM OSC & SECTOR DEMODULATOR TYPE ØVAV		19333	C 54180200
CD			5

54180200 B

4

3

2

1

SHEET REVISION STATUS		REVISION RECORD			
REV	ECO	DESCRIPTION	DFT	DATE	CHKD
A	FE2300	RELEASED		11-2-71	

2.2B 2.4B 2.6B 2.8B 3.1B 3.2B 3.4B 3.6B 3.8B 4.0B 4.2B 4.4B 4.6B 4.8B 5.0B 5.2B 5.4B 5.6B 5.8B 6.0B 6.2B 6.4B 6.6B 6.8B 7.0B 7.2B 7.4B 7.6B 7.8B 8.0B 8.2B 8.4B 8.6B 8.8B 9.0B 9.2B 9.4B 9.6B 9.8B 10.0B

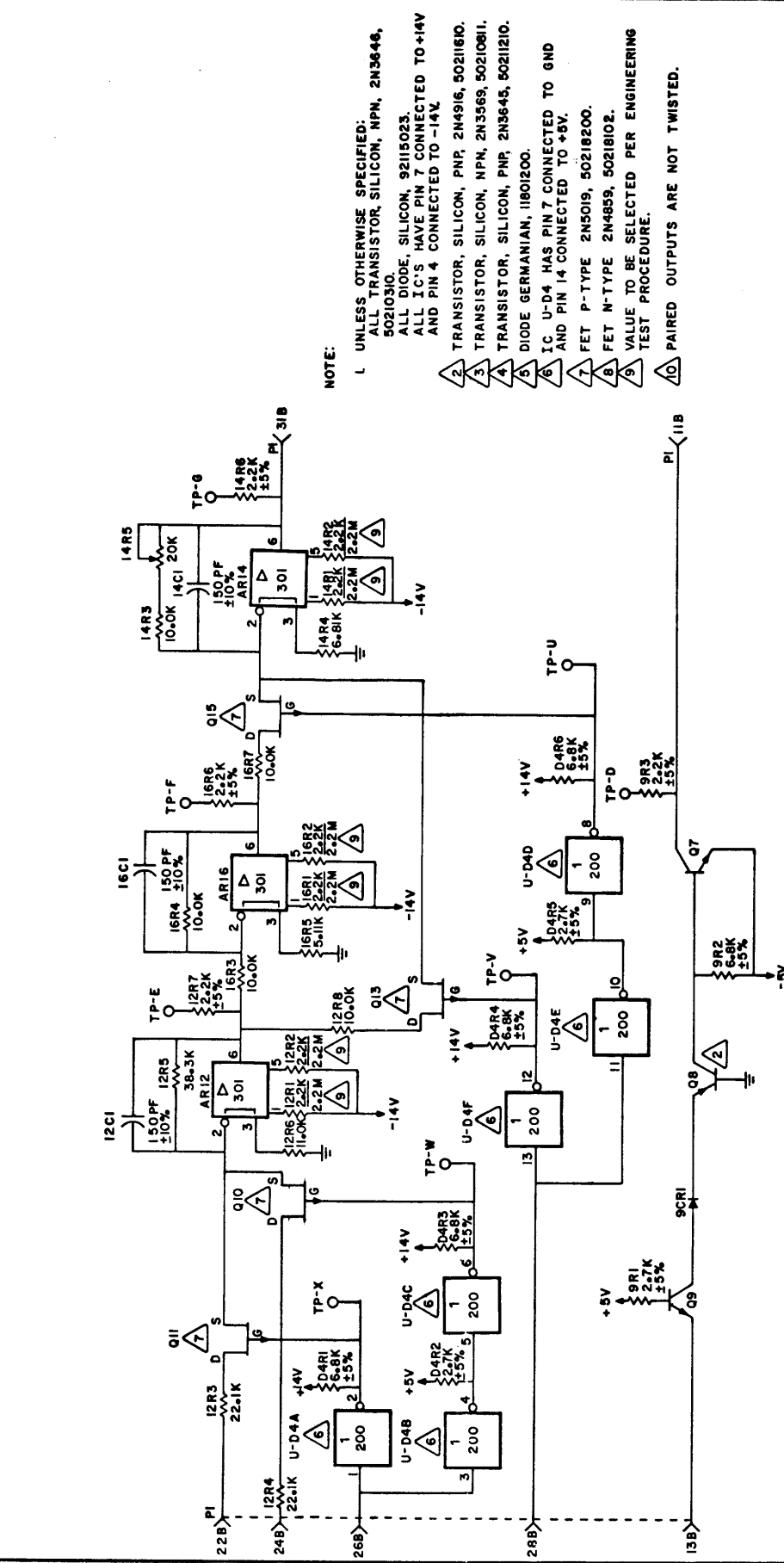

NOTE:

- UNLESS OTHERWISE SPECIFIED:
ALL TRANSISTOR, SILICON, NPN, 2N3646, 50210310.
ALL DIODE, SILICON, 92115023.
ALL IC'S HAVE PIN 7 CONNECTED TO +14V AND PIN 4 CONNECTED TO -14V.
- TRANSISTOR, SILICON, PNP, 2N4916, 50211610.
- TRANSISTOR, SILICON, NPN, 2N3569, 50210811.
- TRANSISTOR, SILICON, PNP, 2N3645, 50212101.
- DIODE GERMANIAN, 1801200.
- IC U-D4 HAS PIN 7 CONNECTED TO GND AND PIN 14 CONNECTED TO +5V.
- FET P-TYPE 2N5019, 50218200.
- FET N-TYPE 2N4859, 50218102.
- VALUE TO BE SELECTED PER ENGINEERING TEST PROCEDURE.
- PAIRED OUTPUTS ARE NOT TWISTED.

REFERENCE DRAWINGS		CONTROL DATA	NORMAN DALE	DIVISION		
COMPONENT ASSY 54189900		BRSAIA	B/3/71			
DWN		G. MARTIN	11/1/71			
CHK		H. HARRISON	11/1/71			
ENGR		N. S. PETERSON	11/1/71			
MTC		J. P. ...	11/1/71			
APP		J. S. ...	11/1/71			
RES ± 1%		OHMS	RATING		CAP	
CAP -30%		1/4W				

TITLE
SCHEMATIC DIAGRAM
50KHZ OSC. & ANALOG SWITCH
TYPE 1VY1

CODE IDENT	19333	DRAWING NUMBER	54189900	CD	0
SHEET 1 OF 2	1	2	3	4	1

← B54189900

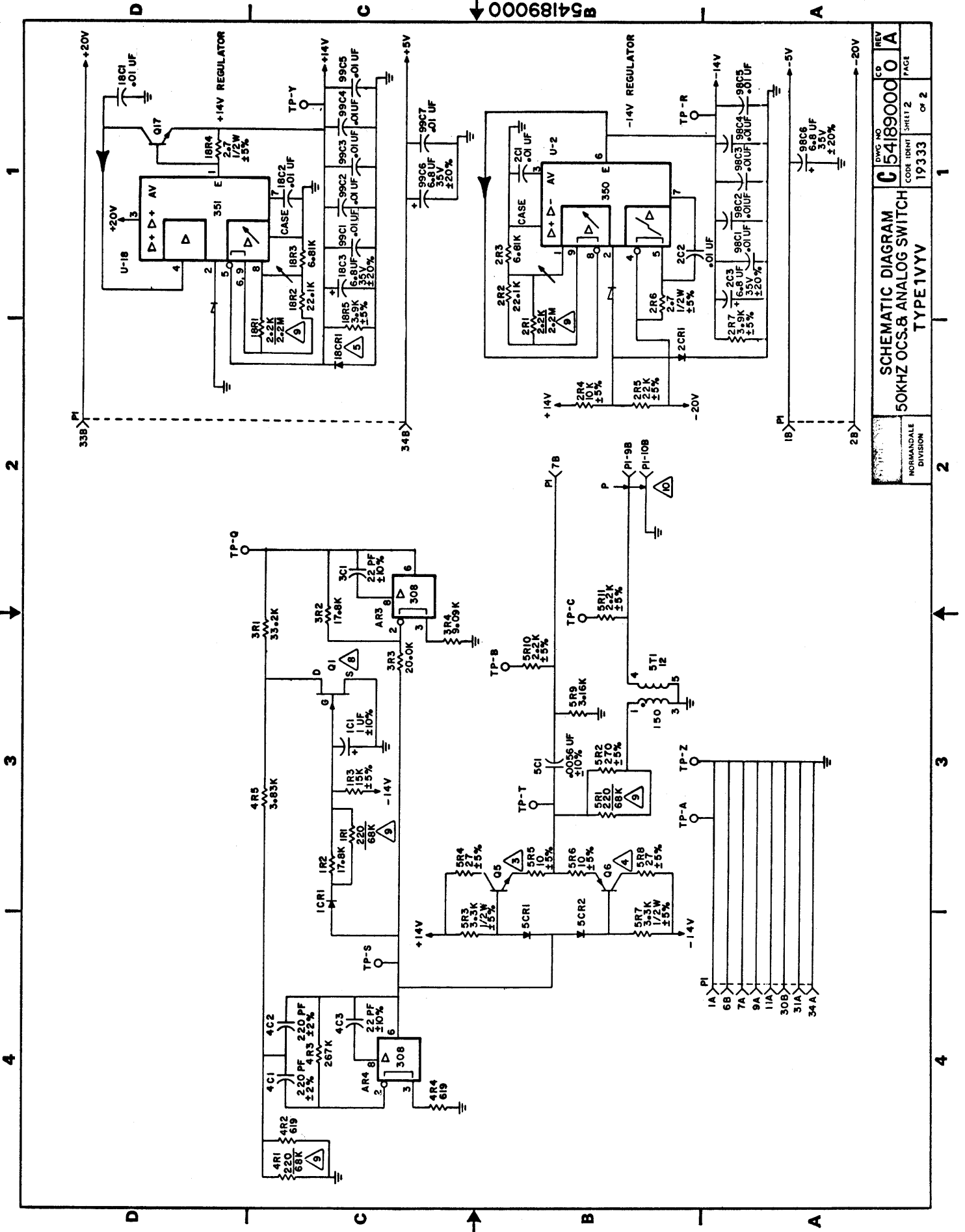

REV	CD	REV	CD
	0	0	0
PAGE		PAGE	
19333		19333	
of 2		of 2	
SCHEMATIC DIAGRAM 50KHZ OCS.8 ANALOG SWITCH TYPE 1VYV			
NORMANDALE		NORMANDALE	
DIVISION		DIVISION	

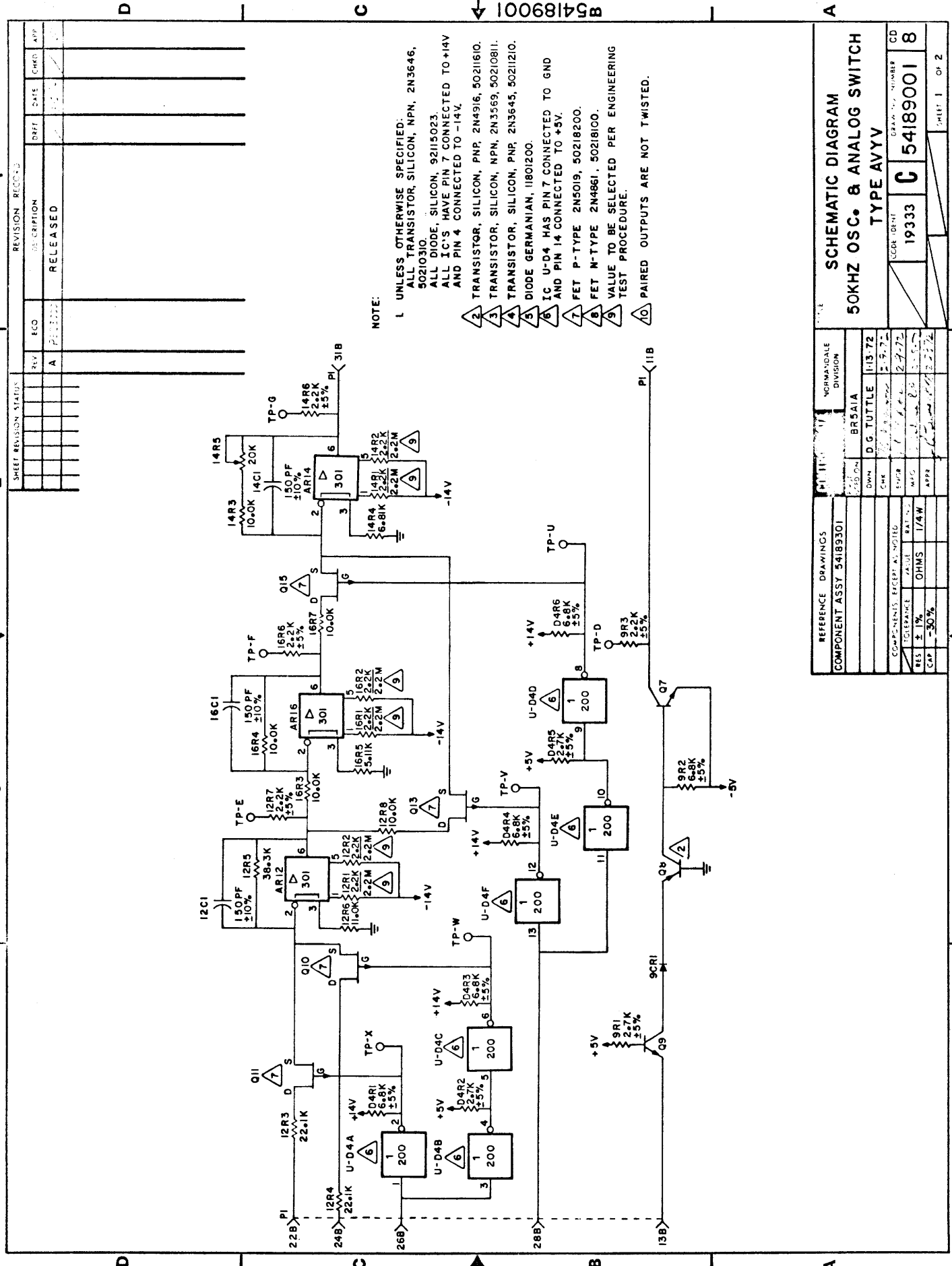

- NOTE:
- 1 UNLESS OTHERWISE SPECIFIED:
ALL TRANSISTOR, SILICON, NPN, 2N3646,
50210310.
ALL DIODE, SILICON, 92115023.
ALL IC'S HAVE PIN 7 CONNECTED TO +14V
AND PIN 4 CONNECTED TO -14V.
 - 2 TRANSISTOR, SILICON, PNP, 2N4916, 50211610.
 - 3 TRANSISTOR, SILICON, NPN, 2N3569, 50210811.
 - 4 TRANSISTOR, SILICON, PNP, 2N3645, 50211210.
 - 5 DIODE GERMANIAN, 11801200.
 - 6 IC U-D4 HAS PIN 7 CONNECTED TO GND
AND PIN 14 CONNECTED TO +5V.
 - 7 FET P-TYPE 2N5019, 50218200.
 - 8 FET N-TYPE 2N4861, 50218100.
 - 9 VALUE TO BE SELECTED PER ENGINEERING
TEST PROCEDURE.
 - 10 PAIRED OUTPUTS ARE NOT TWISTED.

SHEET REVISION STATUS		REVISION RECORD	
REV	ECO	DESCRIPTION	DATE
A		RELEASED	

REFERENCE DRAWINGS		NORMANDAILE DIVISION	
COMPONENT ASSY	PI IIB	BRSAIA	D G TUTTLE
54189301			
COMPONENTS EXCEPT AS NOTED		DATE	BY
TOLERANCE		1-13-72	
RES ± 1%	OHMS 1/4W	2-7-72	
CAP ± 30%			

SCHEMATIC DIAGRAM		TYPE AVVY	
50KHZ OSC. & ANALOG SWITCH		19333	C 54189001
CD		DRAWING NUMBER	
VCP		SHEET 1 OF 2	

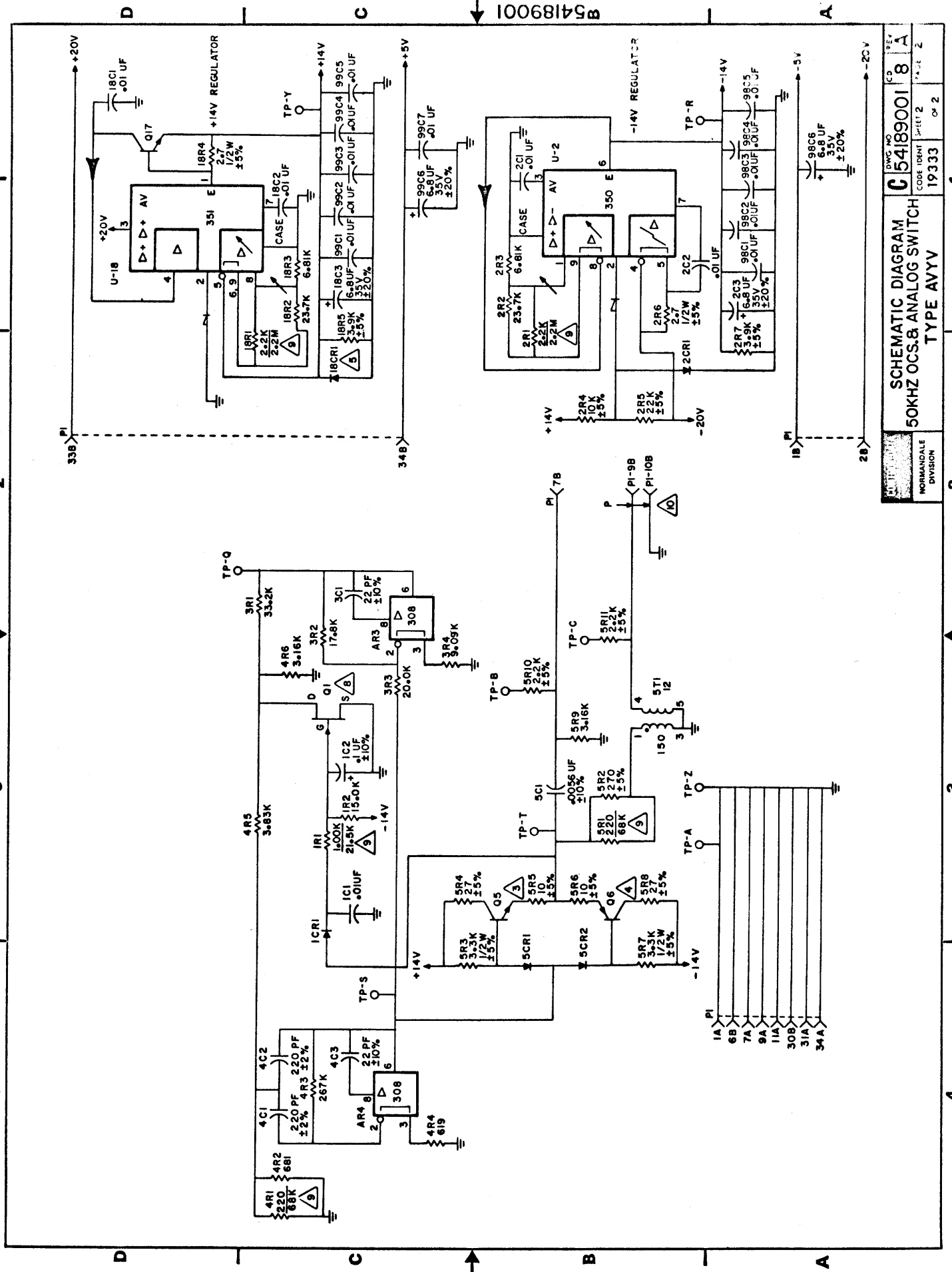

DWG NO **C54189001** 8
 CODE IDENT **19333** OF 2
 SCHEMATIC DIAGRAM
 50KHZ OCS.8 ANALOG SWITCH
 TYPE AVYY
 NORMANDEALE
 DIVISION

B54189001

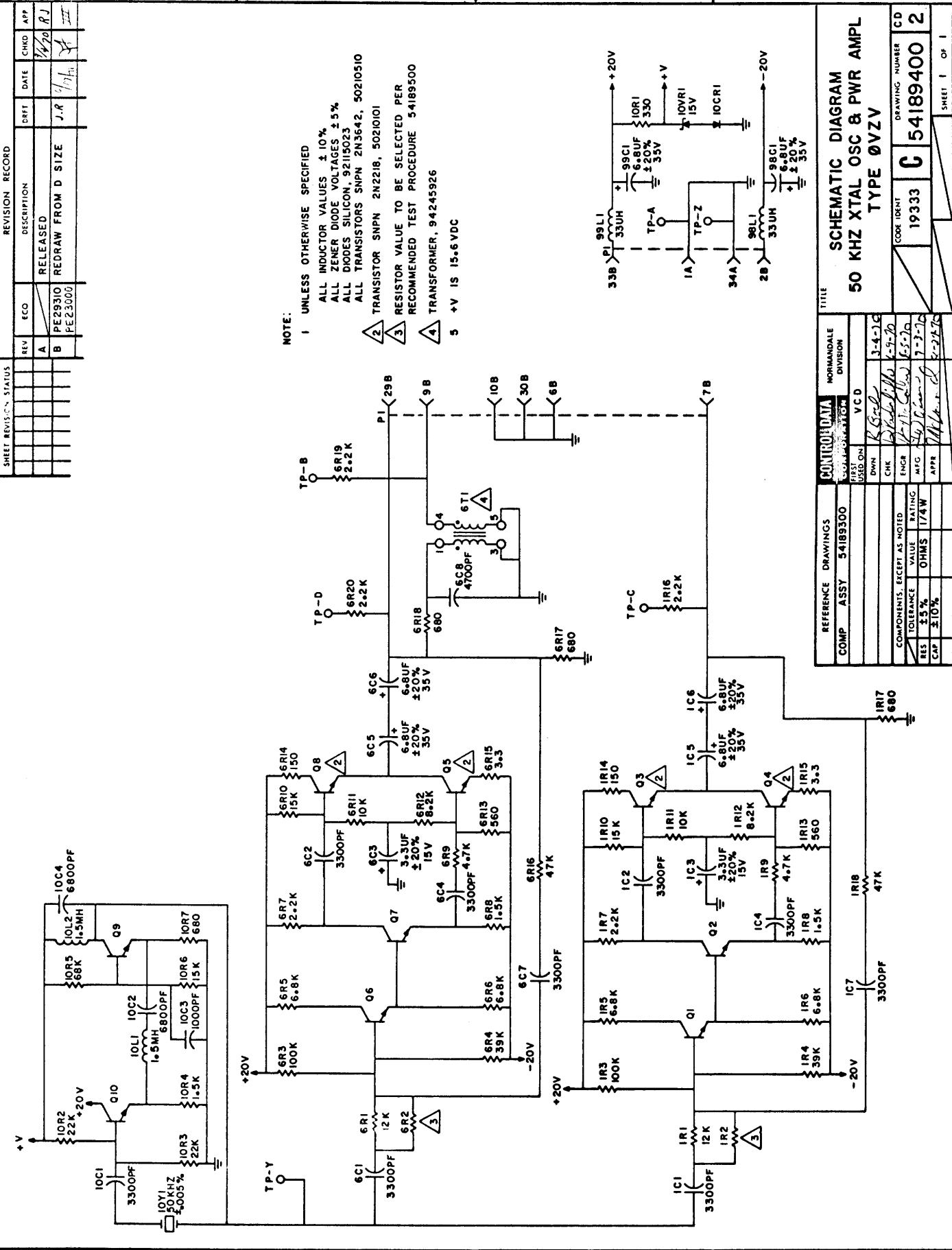

NOTE:
 1 UNLESS OTHERWISE SPECIFIED
 ALL INDUCTOR VALUES ±10%
 ALL ZENER DIODE VOLTAGES ±5%
 ALL DIODES SILICON, 92115023
 ALL TRANSISTORS SNPN 2N3642, 50210510
 2 TRANSISTOR SNPN 2N2219, 50210101
 3 RESISTOR VALUE TO BE SELECTED PER
 RECOMMENDED TEST PROCEDURE 54189500
 4 TRANSFORMER, 94245926
 5 +V IS 15.6VDC

REVISION RECORD		SHEET REVISION STATUS		CONTROL DATA		REFERENCE DRAWINGS		NORMANDALE DIVISION	
REV	ECO	DESCRIPTION	DRBT	DATE	CHKD	APP	COMP	ASSY	COMPONENTS EXCEPT AS NOTED
A		RELEASED					4189300		DWN
B	PE29310	REDRAW FROM D SIZE	J.R.	1/17/60					ENGR
	PE23000								MFC
									MFG
									RES
									VAL
									OHMS
									1/4 W
									CAP
									±10%
					TITLE				
					50 KHZ XTAL OSC & PWR AMPL				
					TYPE 0VZV				
					DRAWING NUMBER				
					19333				
					CODE DENT				
					C				
					DRAWING NUMBER				
					54189400				
					CD				
					2				
					SHEET 1 OF 1				

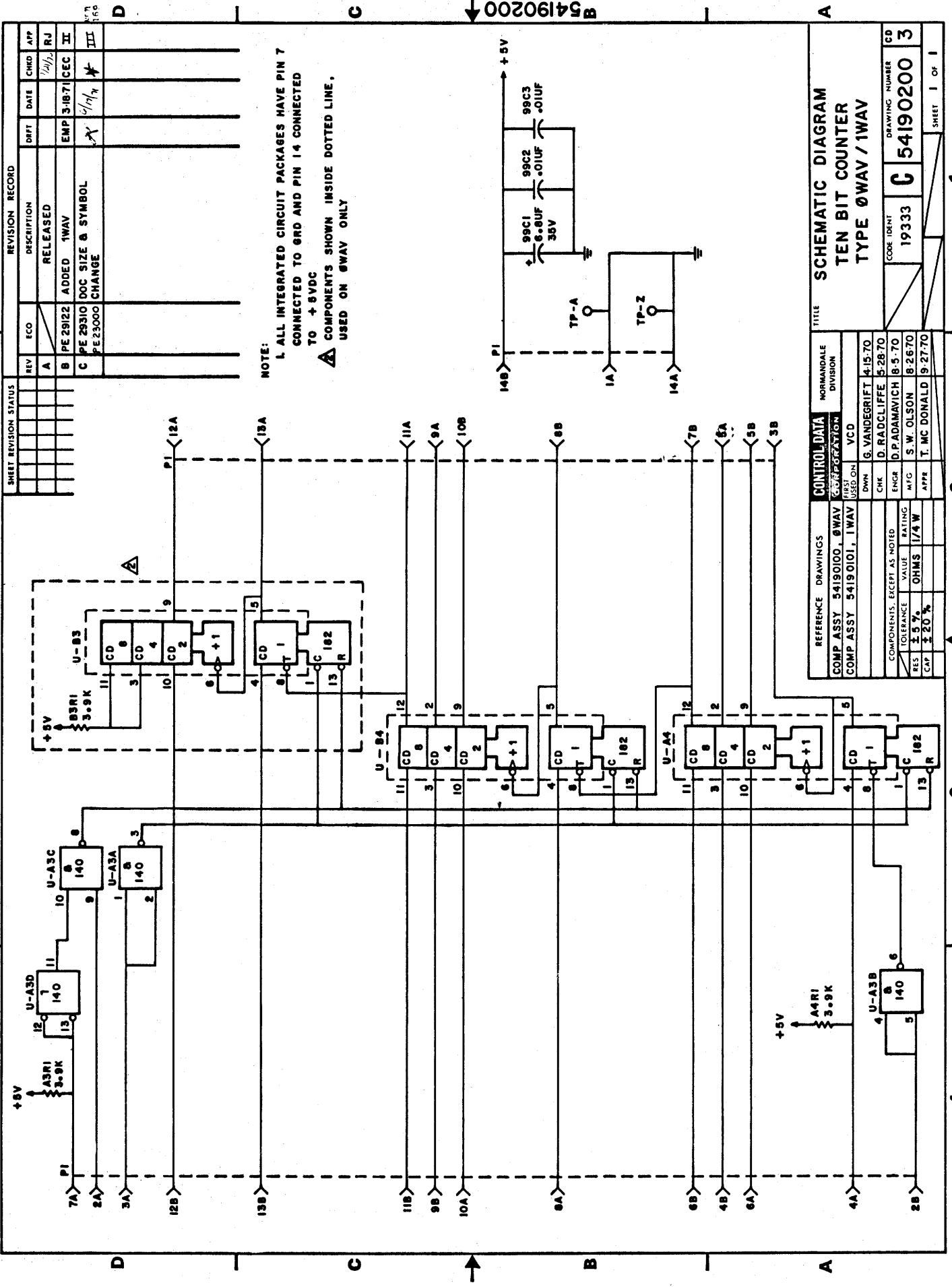

NOTE:
 1. ALL INTEGRATED CIRCUIT PACKAGES HAVE PIN 7 CONNECTED TO GND AND PIN 14 CONNECTED TO +5VDC
 2. COMPONENTS SHOWN INSIDE DOTTED LINE, USED ON 6WAY ONLY

REVISION RECORD						
REV	ECO	DESCRIPTION	DRFT	DATE	CHKD	APP
A		RELEASED				
B	PE29122	ADDED 1WAY	EMP	3-18-71	CEC	II
C	PE29310	DOC SIZE & SYMBOL CHANGE		4/17/71		III
D						

REFERENCE DRAWINGS		CONTROL DATA		NORMANDALE DIVISION	
COMP ASSY	54190100, 6WAY	COMP ASSY	54190101, 1WAY	CD	54190200
DWN	G. VANDEGRIFT	CHK	D. RADCLIFFE	19333	19333
ENGR	D.P. DAMAVICH	MFG	S.W. OLSON	19333	19333
APPR	T. MC DONALD	DATE	9-27-70	19333	19333

TITLE		SCHEMATIC DIAGRAM	
TEN BIT COUNTER		TYPE 6WAY / 1WAY	
CODE IDENT	19333	DRAWING NUMBER	54190200
SHEET 1 OF 1		SHEET 1 OF 1	

54190200

1

2

3

4

D

C

B

A

SHEET REVISION STATUS		REVISION RECORD			
REV	ECO	DESCRIPTION	DRFT	DATE	CHKD APP
A		RELEASED	J.R.	4/11/70	J.R.
B	PE29310	DOC SIZE & SYM CHANGE	J.R.	4/11/70	J.R.
	PE23000				

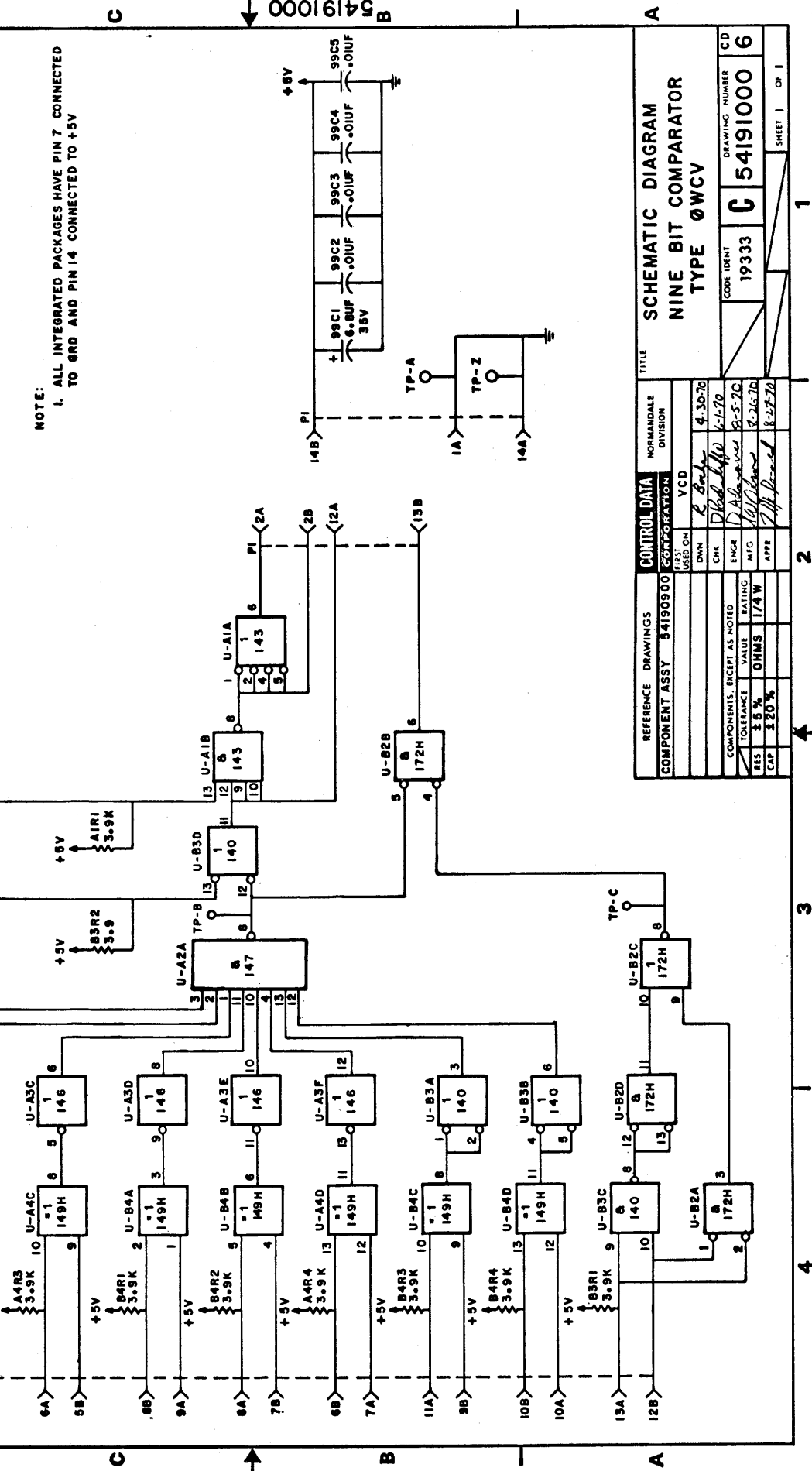

NOTE:
1. ALL INTEGRATED PACKAGES HAVE PIN 7 CONNECTED TO GRD AND PIN 14 CONNECTED TO +5V

REFERENCE DRAWINGS		CONTROL DATA		NORMANDALE DIVISION	
COMPONENT ASSY	54190900	COMPONENT	54191000	VCD	4-3070
RES	± 5%	OHMS	1/AW	ENGR	D. A. ...
CAP	± 20%	APPX		MFG	B-5-70
		DATE	8-22-70	CHK	R. ...
		APPX		APPX	J. ...

TITLE		DRAWING NUMBER	
SCHEMATIC DIAGRAM		CD	
NINE BIT COMPARATOR		54191000	
TYPE ØWC		19333	
SHEET 1 OF 1			

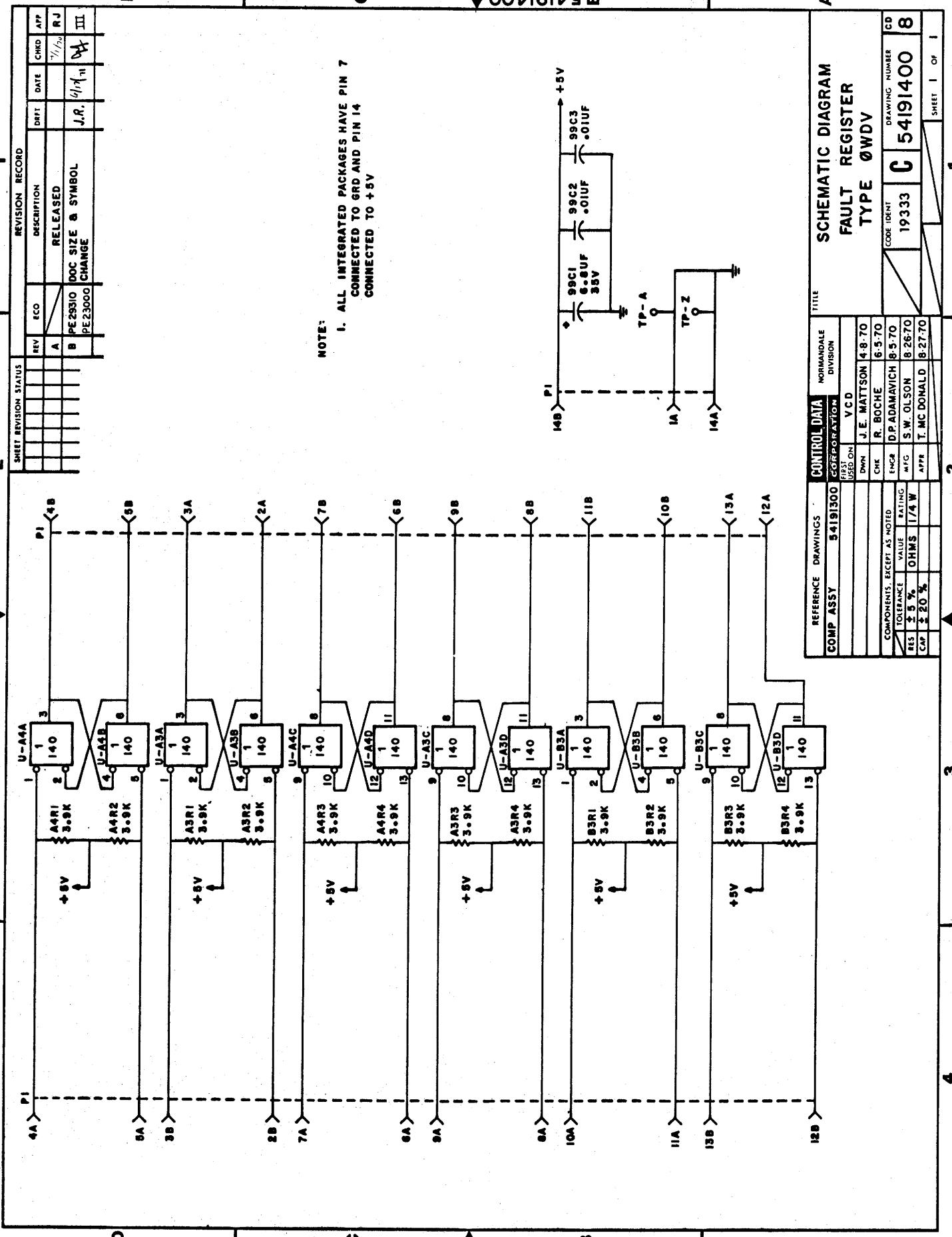

NOTE:
1. ALL INTEGRATED PACKAGES HAVE PIN 7
CONNECTED TO GRD AND PIN 14
CONNECTED TO +5V

SHEET REVISION STATUS		REVISION RECORD				
REV	ECO	DESCRIPTION	DRFT	DATE	CHKD	APP
A		RELEASED		11/17/70		RJ
B		DOC SIZE & SYMBOL CHANGE		1/17/71		J.R.
						III

REFERENCE DRAWINGS		CONTROL DATA		NORMANDALE DIVISION		
COMP ASSY	DRAWINGS	CORPORATION	DESIGN	DATE	TITLE	
54191300		WEST LON	VCD	4-8-70	SCHEMATIC DIAGRAM FAULT REGISTER TYPE ØWDV	
		J.E. MATTSON		6-5-70		
		CHK	R. BOCHE	8-5-70	CODE IDENT 19333	
		ENGR	DP ADAMAVICH	8-5-70		
		MFG	S.W. OLSON	8-26-70		
		APPR	T. MC DONALD	8-27-70	DRAWING NUMBER 54191400	
					CD	8

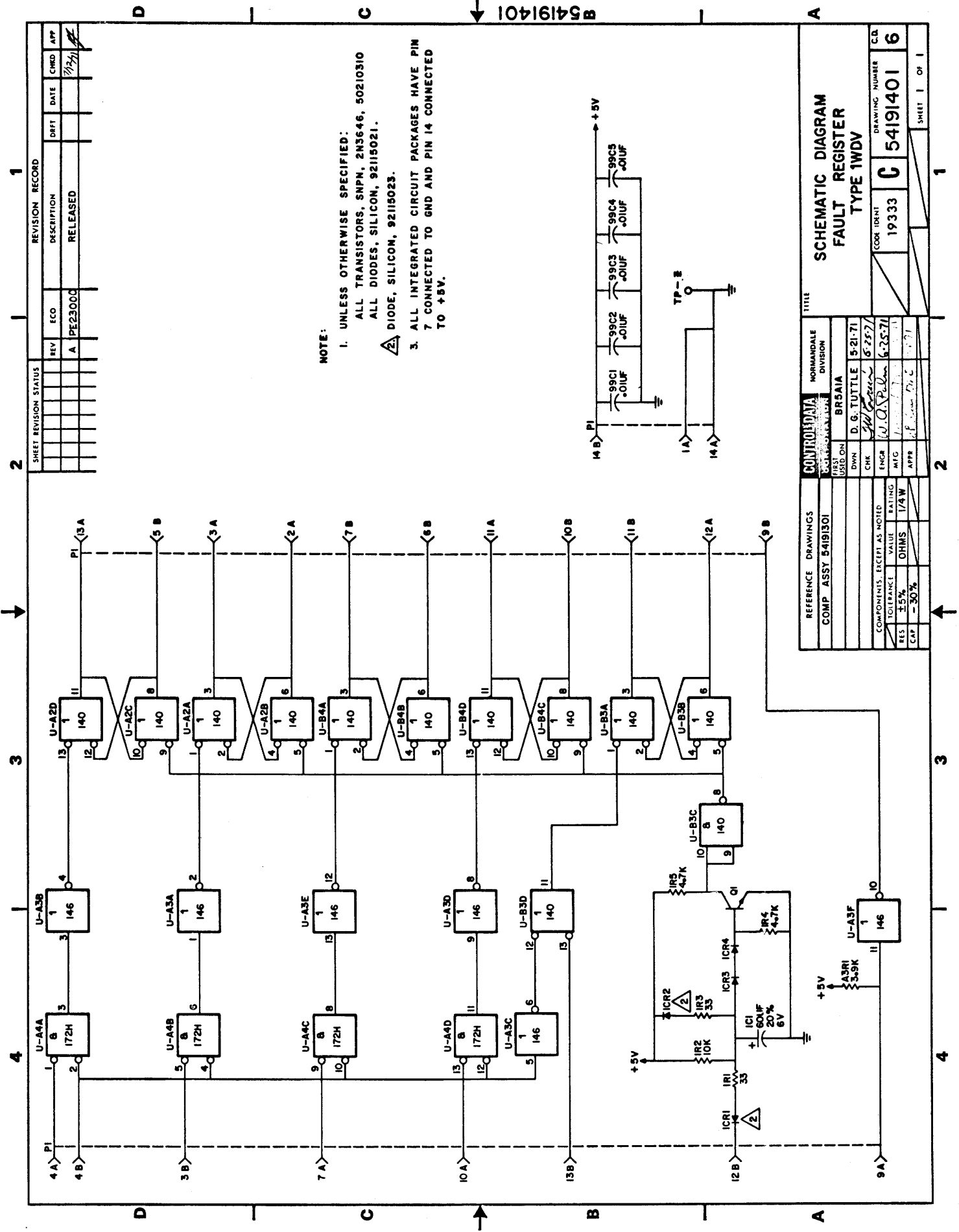

NOTE:

- UNLESS OTHERWISE SPECIFIED:
ALL TRANSISTORS, SNPN, 2N3646, 50210310
ALL DIODES, SILICON, 92115021.
▲ DIODE, SILICON, 92115023.
- ALL INTEGRATED CIRCUIT PACKAGES HAVE PIN 7 CONNECTED TO GND AND PIN 14 CONNECTED TO +5V.

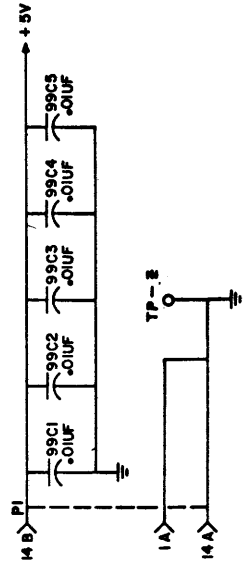

SHEET REVISION STATUS		REVISION RECORD	
REV	ECO	DESCRIPTION	DATE
A	PE23000	RELEASED	7/3/71

REFERENCE DRAWINGS		CONTROL DATA		NORMANDALE DIVISION		TITLE		
COMP ASSY 54191301	BRSA1A	DWN	D. G. TUTTLE	5-21-71	6-25-71	19333	C 54191401	
COMPONENTS, EXCEPT AS NOTED	RES ±5%	OHMS	1/AW	APPR	DATE	COOK IDENT	DRAWING NUMBER	
TOLERANCE VALUE	CAP -30%						6	
							19333	C 54191401
							1	1

B 54191401

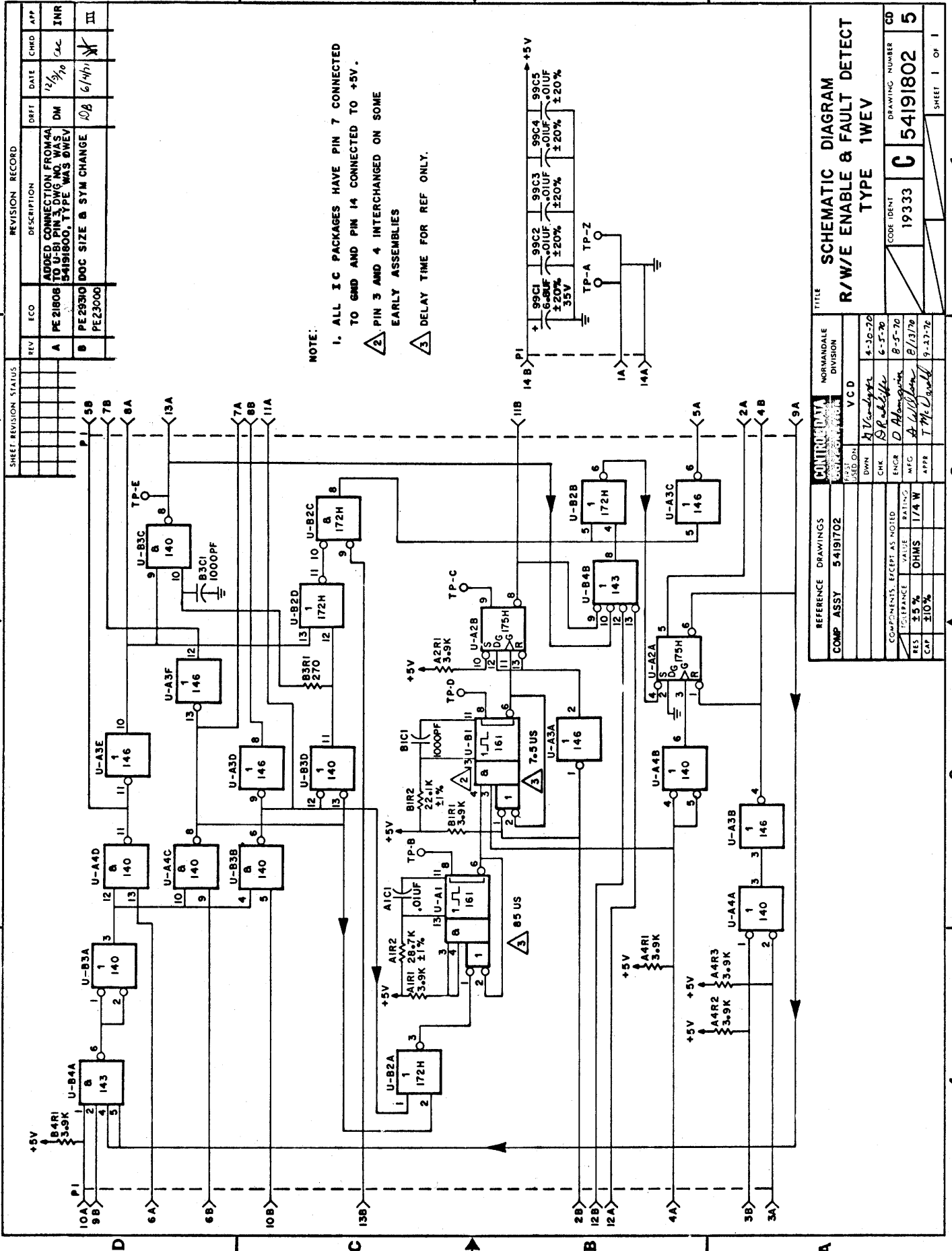

B54191802

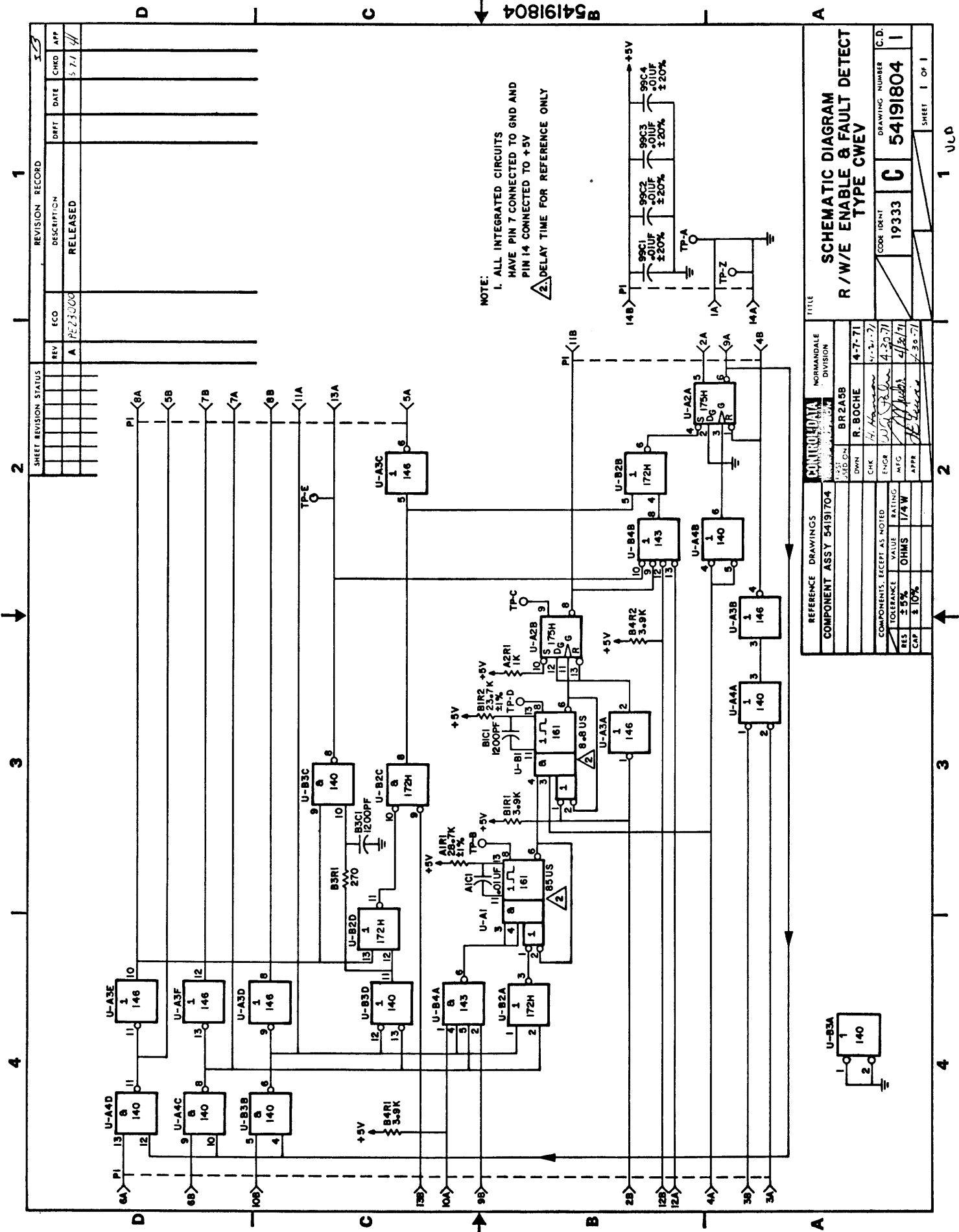

NOTE:
 1. ALL INTEGRATED CIRCUITS
 HAVE PIN 7 CONNECTED TO GND AND
 PIN 14 CONNECTED TO +5V
 2. DELAY TIME FOR REFERENCE ONLY

REV	ECO	DESCRIPTION	DATE	DRFT	CHKD	APP
A	PE23000	RELEASED	5/7/74			

SHEET REVISION STATUS		REVISION RECORD	
NO.	DESCRIPTION	DATE	BY
1			
2			
3			
4			

REFERENCE DRAWINGS		NORMANDALE DIVISION	
COMPONENT ASSY 54191704	BR2A08	R. BOICHE	4-7-71
COMPONENTS EXCEPT AS NOTED		CHK	4-23-71
TOLERANCE	VALUE	ENGR	4-23-71
RES	± 5%	MFG	4/23/71
CAP	± 10%	APPR	4-23-71

TITLE		DRAWING NUMBER	
SCHEMATIC DIAGRAM		54191804	
R/W/E ENABLE & FAULT DETECT		C.D.	
TYPE CWEY		1	
CODE IDENT		19333	
SHEET 1 OF 1		U.L.P.	

SHEET REVISION STATUS		REVISION RECORD		
REV	ECO	DESCRIPTION	DRFT	DATE
A		PF23000		
		RELEASED		

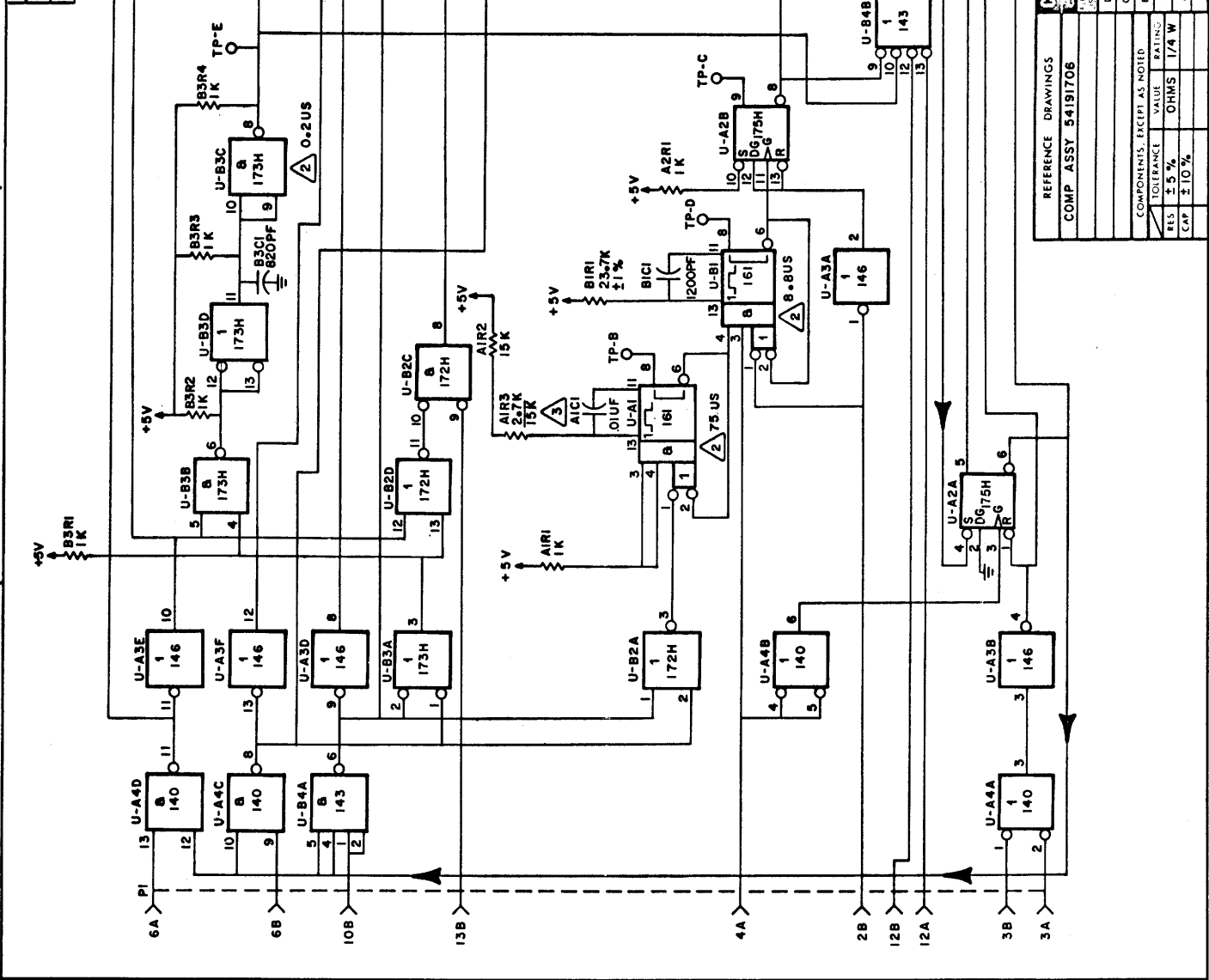

NOTE:
 1. ALL IC PACKAGES HAVE PIN 7 CONNECTED TO GND AND PIN 14 CONNECTED TO +5V.
 2. DELAY TIME FOR REF ONLY.
 3. VALUE TO BE SELECTED PER ENGINEERING TEST PROCEDURE.

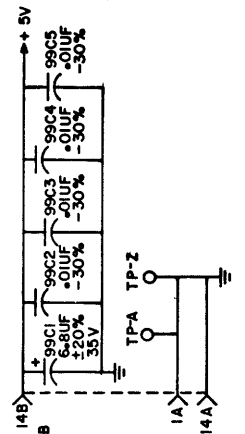

REFERENCE DRAWINGS		NORMANDALE DIVISION	
COMP ASSY 54191706	BR2A3	Q. MARTIN	8/20/71
		ENG. B. J. WOODS	8-31-71
		APP. S. J. WOODS	8-31-71
			8-31-71

TITLE		DRAWING NUMBER	
R/W/E ENABLE & FAULT DETECT		54191806	
TYPE DWE		19333	C
		CODE IDENT	1 OF 1

COMPONENTS, EXCEPT AS NOTED		TOLERANCE		RATINGS	
RES	± 5%	OHMS	1/A W		
CAP	± 10%				

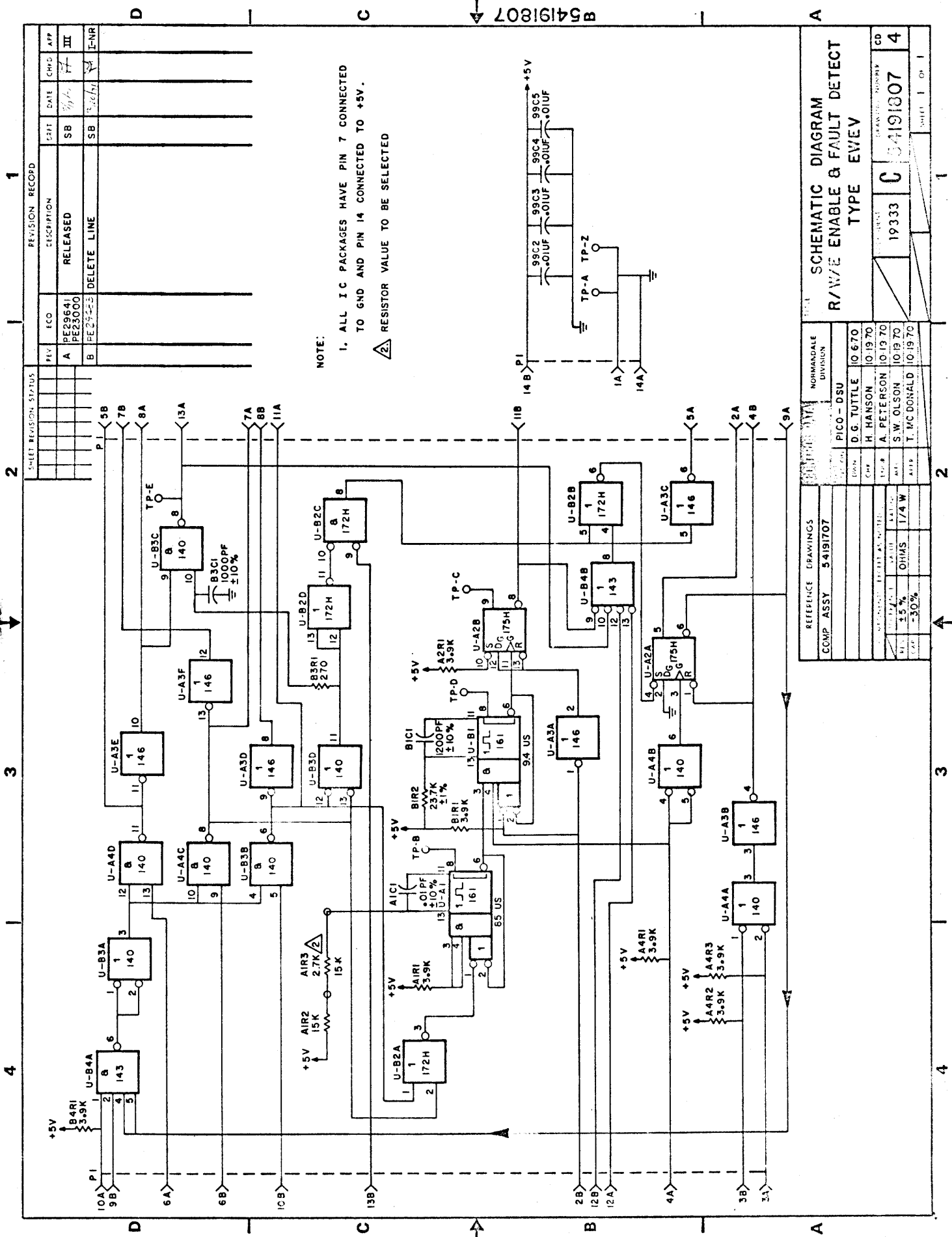

REVISION RECORD			
REV	ECO	DESCRIPTION	DATE
A	PE29641 PE29600	RELEASED	SB
B	PE29233	DELETE LINE	SB

SHEET REVISION STATUS			
REV	DATE	CHKD	APP
1			III
2			I-NR

REFERENCE DRAWINGS			
COMP ASSY	NO	DATE	BY
54191707			

SCHEMATIC DIAGRAM R/W/E ENABLE & FAULT DETECT TYPE EVIE			
NO	DATE	BY	CD
1933	10/19/70	A. PETERSON	4
	10/19/70	S.W. OLSON	
	10/19/70	T. MC DONALD	

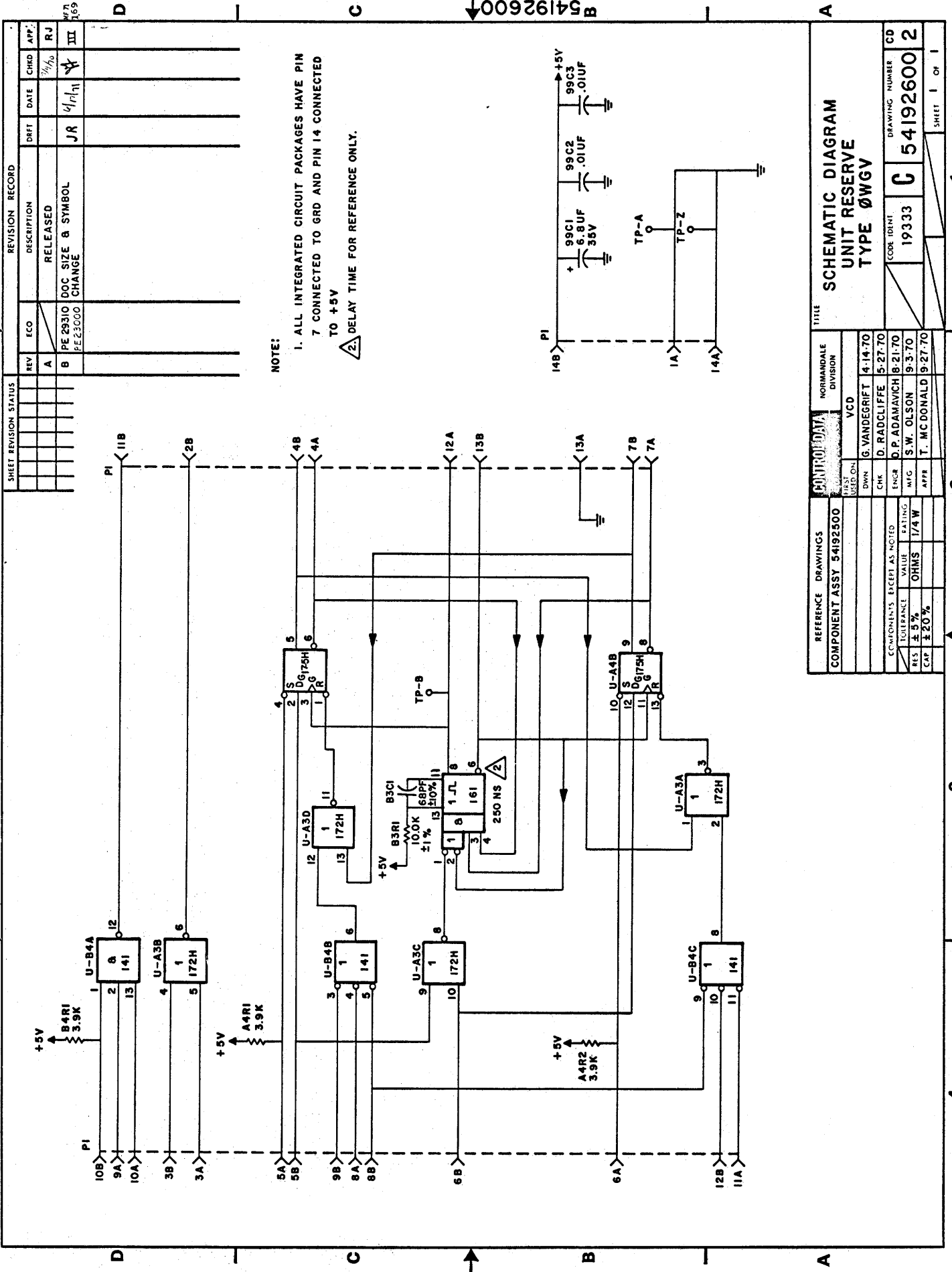

NOTE:
 1. ALL INTEGRATED CIRCUIT PACKAGES HAVE PIN 7 CONNECTED TO GRD AND PIN 14 CONNECTED TO +5V
 2. DELAY TIME FOR REFERENCE ONLY.

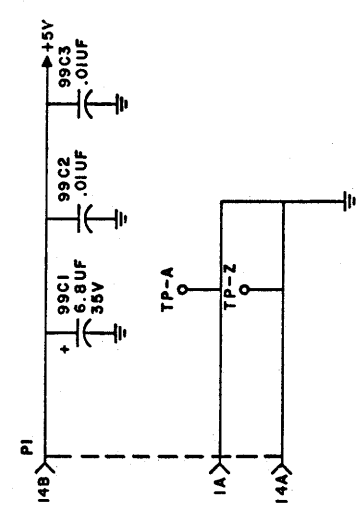

REVISION RECORD			
REV	ECO	DESCRIPTION	DATE
A		RELEASED	
B	PE 29310 FE 23000	DOC SIZE & SYMBOL CHANGE	JR 4/11/71

REV	CHKD	APP.
		RJ
		III

SHEET REVISION STATUS	
NO.	DESCRIPTION
1	
2	
3	
4	

REFERENCE DRAWINGS		CONTROL DATA		NORMANDELE DIVISION	
COMPONENT ASSY	54192600	REV	USED ON	CHK	DATE
			VCD	G. VANDEGRIFT	4-14-70
				D. RADCLIFFE	5-27-70
				D.P. ADAMAVICH	8-21-70
				S.W. OLSON	9-3-70
				T. McDONALD	9-27-70

TITLE		DRAWING NUMBER	
SCHEMATIC DIAGRAM		CD	
UNIT RESERVE		19333	
TYPE DWG		C 54192600 2	

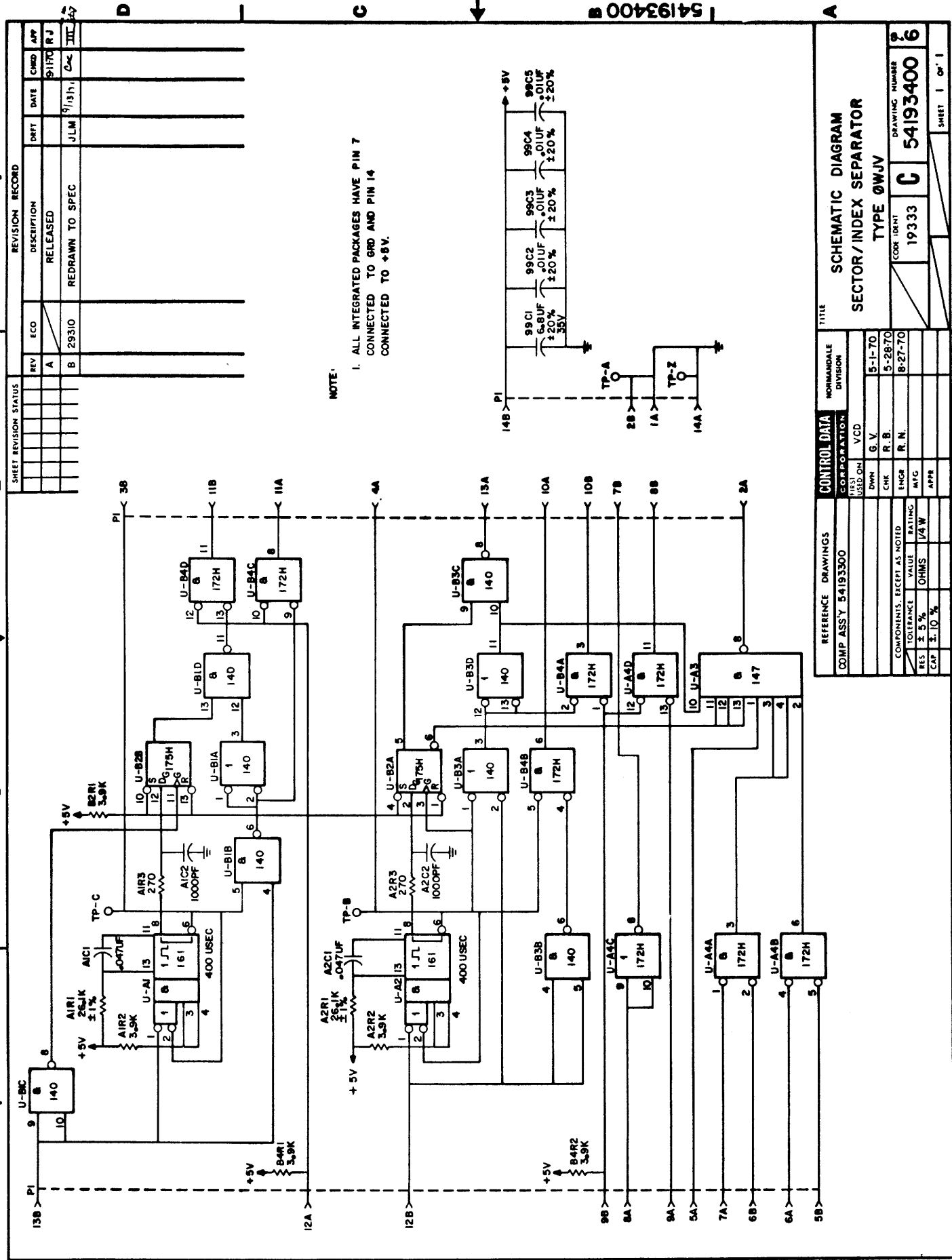

NOTE:
 1. ALL INTEGRATED PACKAGES HAVE PIN 7
 CONNECTED TO GND AND PIN 14
 CONNECTED TO +5V.

SHEET REVISION STATUS		REVISION RECORD	
REV	ECO	DESCRIPTION	DATE
A		RELEASED	9/15/70
B	29310	REDRAWN TO SPEC	9/15/70

REFERENCE DRAWINGS		CONTROL DATA		NORMANDALE DIVISION	
COMP ASSY	54193300	IR33	USED ON	VCD	
DWN	G.V.	5-1-70			
CHK	R.B.	5-28-70			
ENGR	R.N.	8-27-70			
COMPONENTS, EXCEPT AS NOTED					
TOLERANCE	VALUE	RATING	MFG		
RES	± 5%	OHMS	1/4W		
CAP	± 10%		APPR		

TITLE		DRAWING NUMBER	
SCHEMATIC DIAGRAM		54193400	
SECTOR/INDEX SEPARATOR		TYPE 0WJV	
COR IDENT		19333	
SHEET 1 OF 1		VCD	

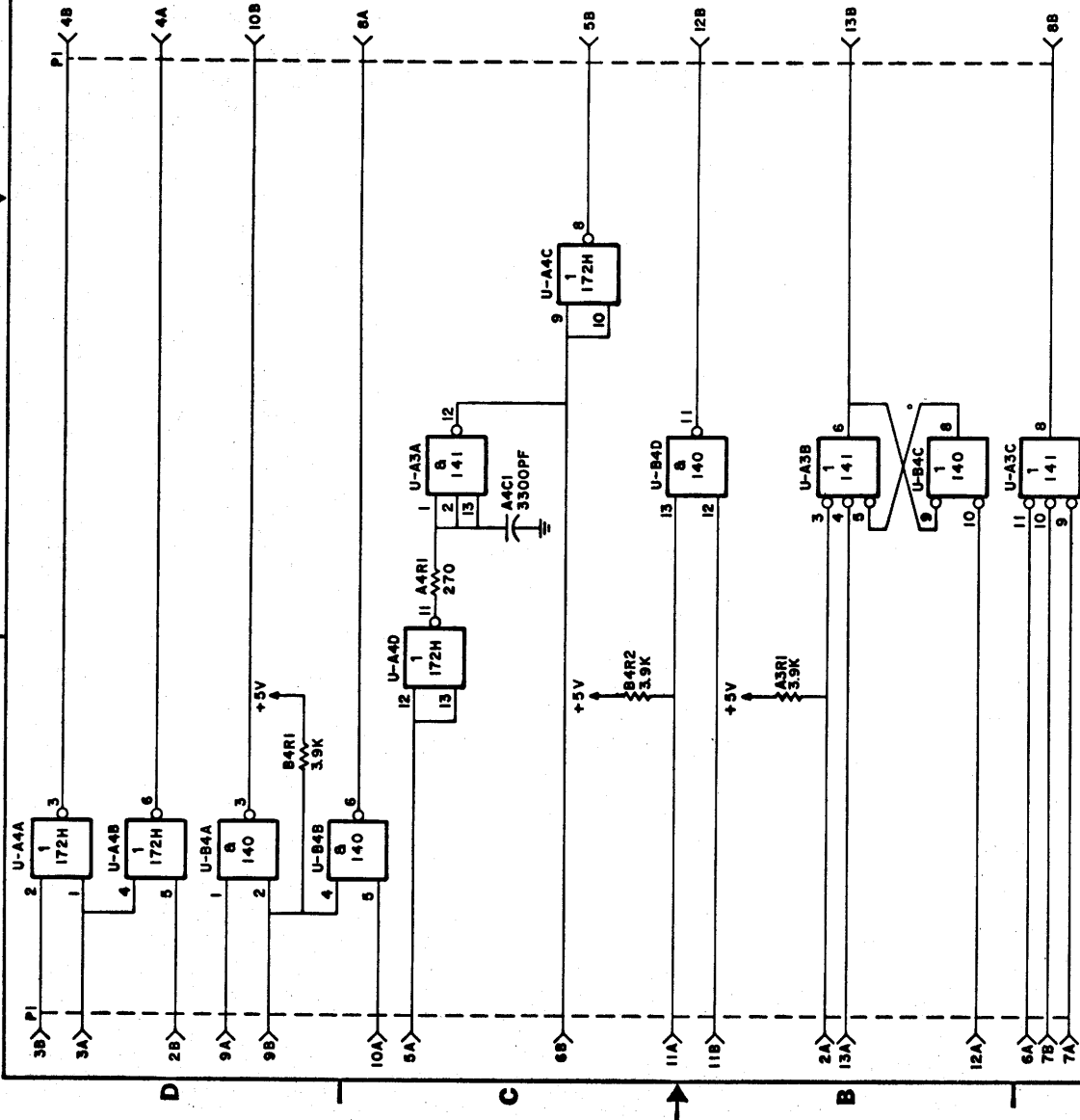

NOTE:
 1 ALL INTEGRATED CIRCUIT PACKAGES HAVE
 PIN 7 CONNECTED TO GND AND PIN 14
 CONNECTED TO +5V

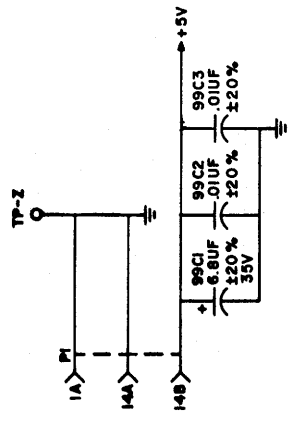

SHEET REVISION STATUS		REVISION RECORD			
REV	ECC	DESCRIPTION	DATE	CHKD	APP
A		RELEASED			
B		REDRAW FROM D SIZE	7/5 4/87		
		PE29310			
		PE23000			

REFERENCE DRAWINGS		CONTROL DATA		NORMANDALE DIVISION		TITLE	
COMPONENT ASSEMBLY 54194100		CORPORATION		VCD		SCHEMATIC DIAGRAM	
DATE	USED ON	CHK	ENGR	APPR	DATE	CODE IDENT	DRAWING NUMBER
9/18/78		D. Whelan	G. Peterson	T. McLeod	10/6/78	19333	54194200
COMPONENTS, EXCEPT AS NOTED		TOLERANCE VALUE		RATING		DRAWING NUMBER	
		OHMS		1/4 W		9	
RES	±5%						
CAP	±10%						
				SHEET 1 OF 1			

A

C

D

A

C

D

B54194200

1

2

3

4

1

2

3

4

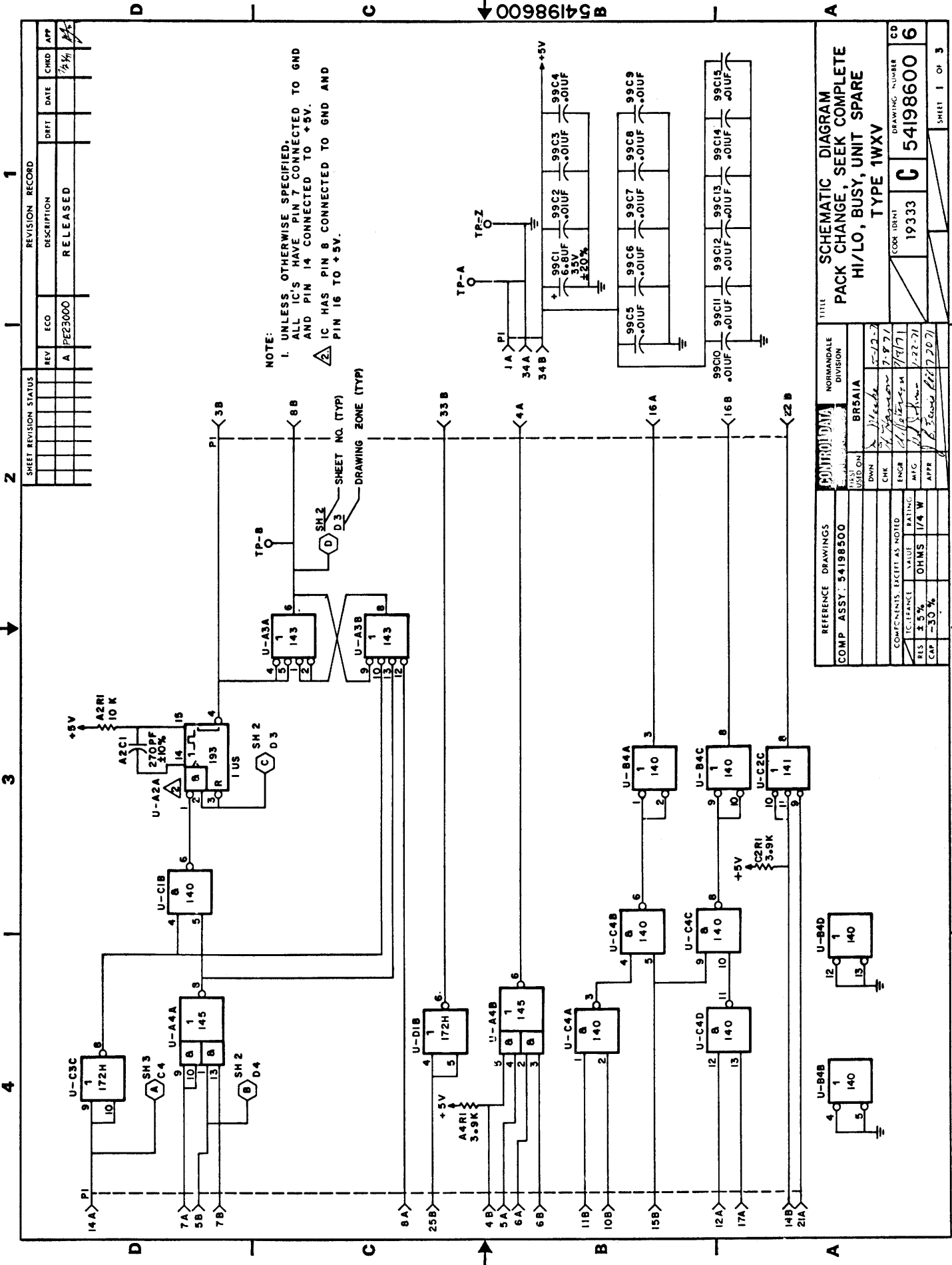

NOTE:
 1. UNLESS OTHERWISE SPECIFIED, ALL IC'S HAVE PIN 7 CONNECTED TO GND AND PIN 14 CONNECTED TO +5V.
 2. IC HAS PIN 8 CONNECTED TO GND AND PIN 16 TO +5V.

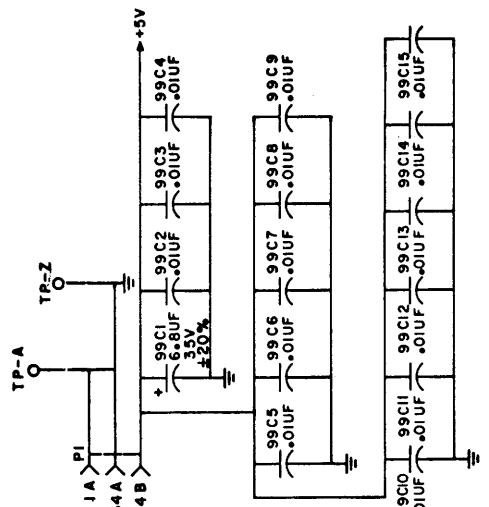

SHEET REVISION STATUS		REVISION RECORD	
REV	ECO	DESCRIPTION	DATE
A	PE23000	RELEASED	1/2/71

REFERENCE DRAWINGS		CONTROL DATA		TITLE	
COMP ASSY:	54198500	DIVISION	NORMANDALE	SCHEMATIC DIAGRAM	
TEST USED ON		BRSAIA		PACK CHANGE, SEEK COMPLETE	
DWN				HI/LO, BUSY, UNIT SPARE	
CHK				GOV. UNIT	19333
ENGR				DRAWING NUMBER	54198600
MTC					6
RES	±5%	OHMS	1/4 W		
CAP	-30%				
APPR					

REV. A	ECO	DESCRIPTION	DATE	CHKD	APP
SEE SHEET 1 FOR REV					

REVISION RECORD

SCHEMATIC DIAGRAM
 PACK CHANGE, SEEK COMPLETE
 HI/LO, BUSY, UNIT SPARE
 C 54198600
 6

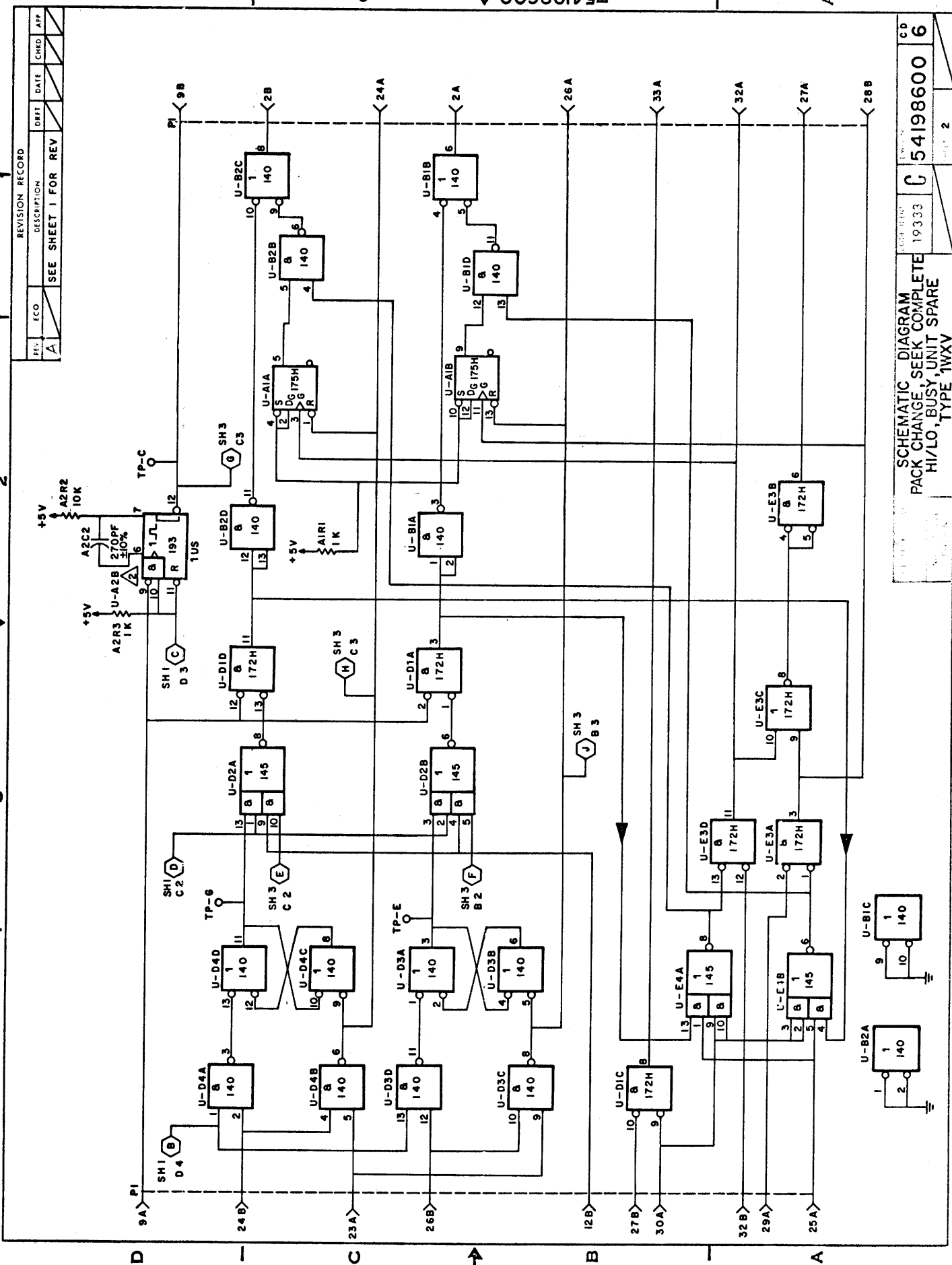

54198600

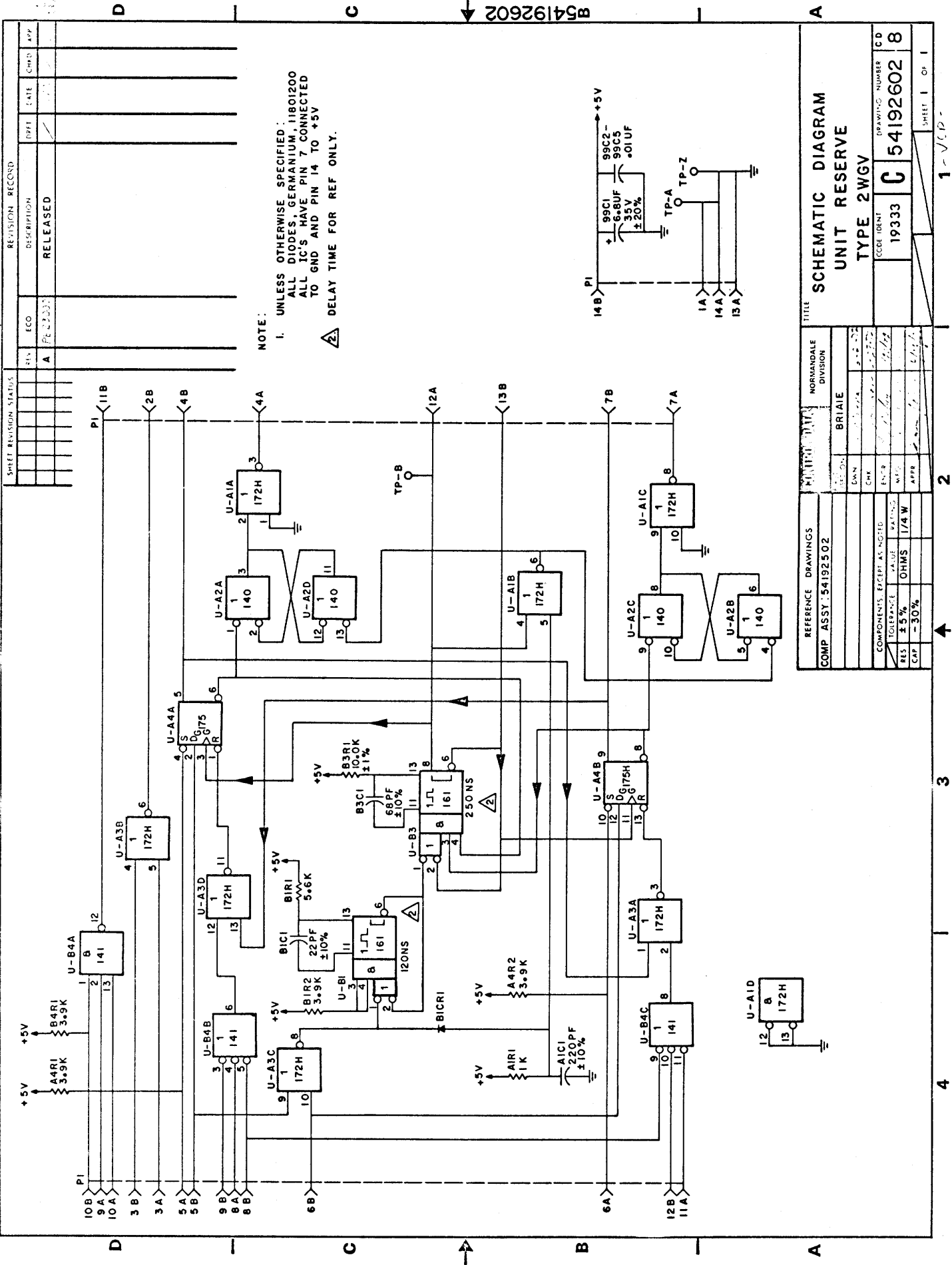

NOTE:

- UNLESS OTHERWISE SPECIFIED:
ALL DIODES, GERMANIUM, 11801200
ALL IC'S HAVE PIN 7 CONNECTED
TO GND AND PIN 14 TO +5V
DELAY TIME FOR REF ONLY.

REV	ECO	DESCRIPTION	DATE	CHKD	APP
A	PC 2333	RELEASED			

SHEET	REVISION	STATUS
1		

TITLE		SCHEMATIC DIAGRAM	
UNIT RESERVE		TYPE 2WG	
DRAWING NUMBER		19333	
DRAWING NUMBER		54192602	
DRAWING NUMBER		8	
DRAWING NUMBER		1	
DRAWING NUMBER		1	

REFERENCE DRAWINGS	NORMANDALE DIVISION		
COMP ASSY: 54192502	BRIA/E		
COMPONENTS, EXCEPT AS NOTED	E/W		
TOLERANCE	1/4 W		
RES	±5%		
CAP	-30%		

B54192602

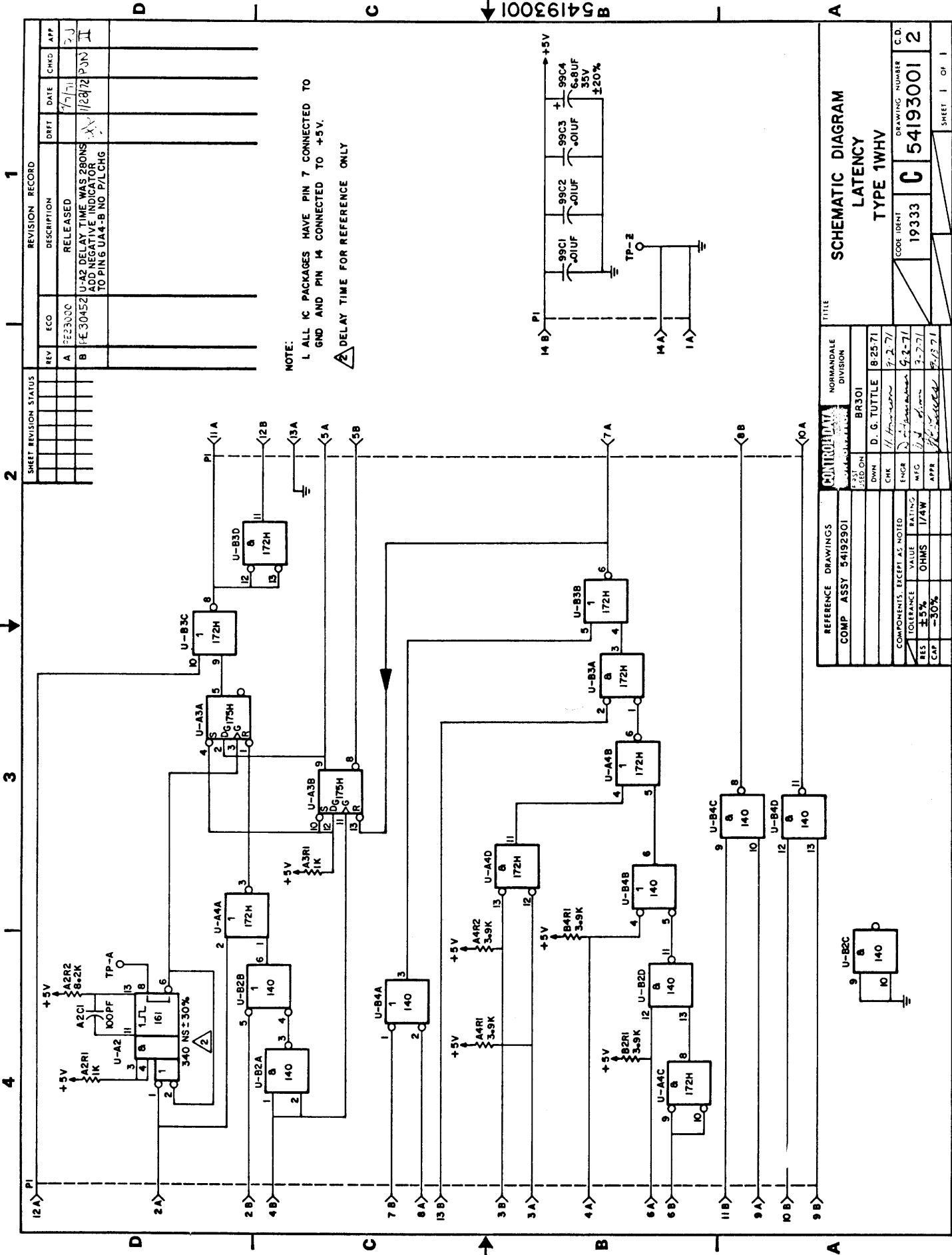

NOTE:
 1. ALL IC PACKAGES HAVE PIN 7 CONNECTED TO GND AND PIN 14 CONNECTED TO +5V.
 2. DELAY TIME FOR REFERENCE ONLY

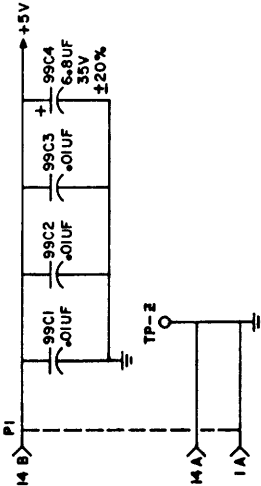

REVISION RECORD		DRFT	DATE	CHKD	APP
REV	ECO				
A	E2300C		7/7/71		JJ
B	E30452		11/28/72	PJN	JJ
DESCRIPTION					
U-A2 DELAY TIME WAS 280NS					
ADD NEGATIVE INDICATOR					
TO PINS U44-B NO. P/L CHG					

REFERENCE DRAWINGS		NORMANDALE DIVISION	
COMP	ASSY 54192901	BR301	
CHK	D. G. TUTTLE	8-25-71	
ENGR		9-2-71	
MFG		9-2-71	
APPR		9-13-71	
TITLE			
SCHEMATIC DIAGRAM			
LATENCY			
TYPE 1WHV			
CODE IDENT	19333	DRAWING NUMBER	C 54193001
SHEET 1 OF 1		C.D.	

SHEET REVISION STATUS	
1	
2	
3	
4	

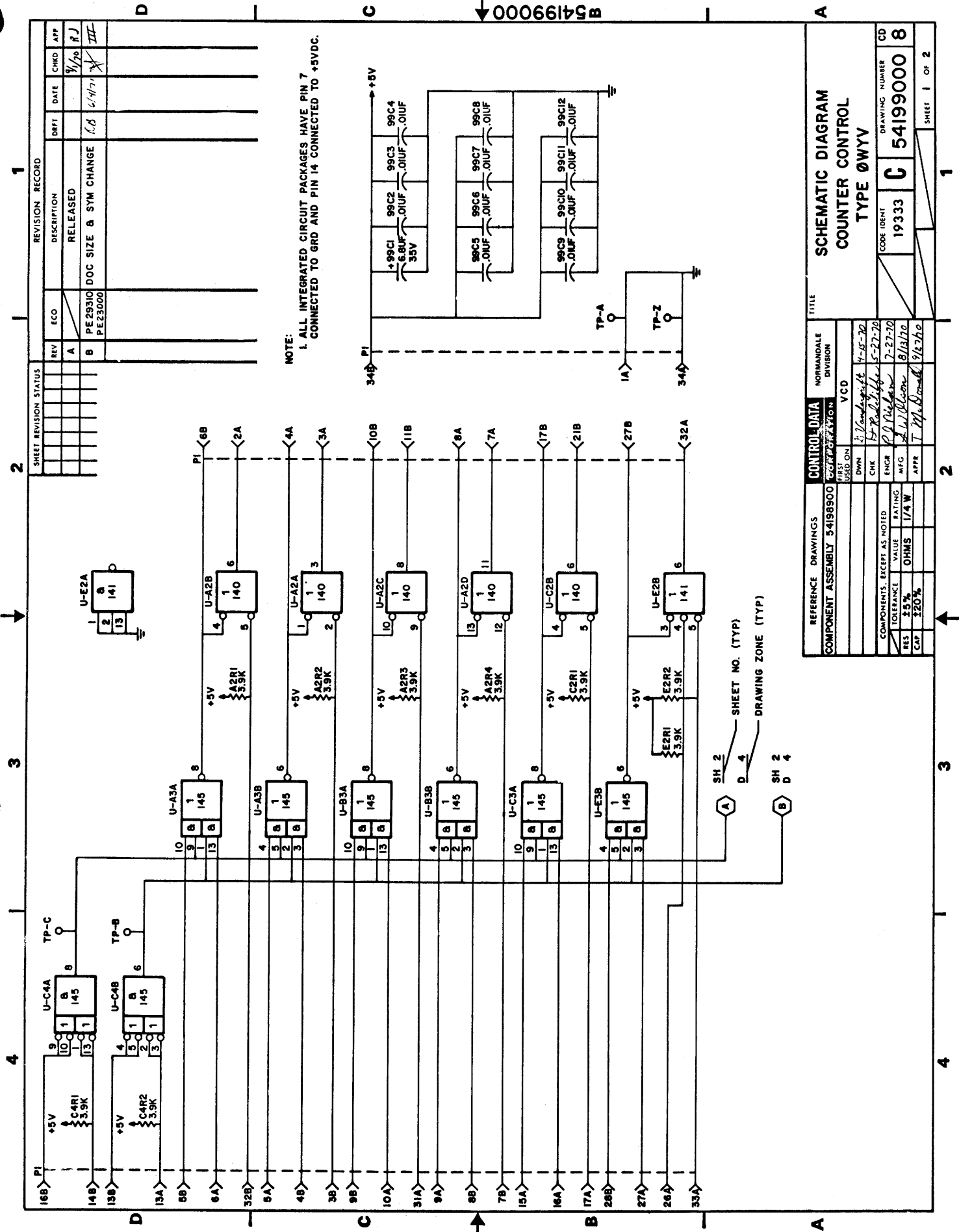

NOTE:
1. ALL INTEGRATED CIRCUIT PACKAGES HAVE PIN 7
CONNECTED TO GRD AND PIN 14 CONNECTED TO +5VDC.

SHEET REVISION STATUS		REVISION RECORD	
REV	ECO	DESCRIPTION	DRFT DATE
A		RELEASED	9/70 RJ
B		PE 29310 DOC SIZE & SYM CHANGE	10/71 X
		PEE3000	

REFERENCE DRAWINGS	CONTROL DATA	NORMANDALE DIVISION	TITLE
COMPONENT ASSEMBLY 54199000	CONFIRMATION		SCHEMATIC DIAGRAM COUNTER CONTROL TYPE ØWY
FIRST USED ON	VCD		
DWN	4-15-70		
CHK	5-27-70		
ENGR	7-27-70		
MFG	8/13/70		
APPR	9/2/70		
RES 15%	OHMS 1/A/W		
CAP 120%			

CODE IDENT	DRAWING NUMBER	CD
19333	C	54199000
		8

CONTROL DATA	CONFIRMATION	NORMANDALE DIVISION	TITLE
COMPONENT ASSEMBLY 54199000	CONFIRMATION		SCHEMATIC DIAGRAM COUNTER CONTROL TYPE ØWY
FIRST USED ON	VCD		
DWN	4-15-70		
CHK	5-27-70		
ENGR	7-27-70		
MFG	8/13/70		
APPR	9/2/70		
RES 15%	OHMS 1/A/W		
CAP 120%			

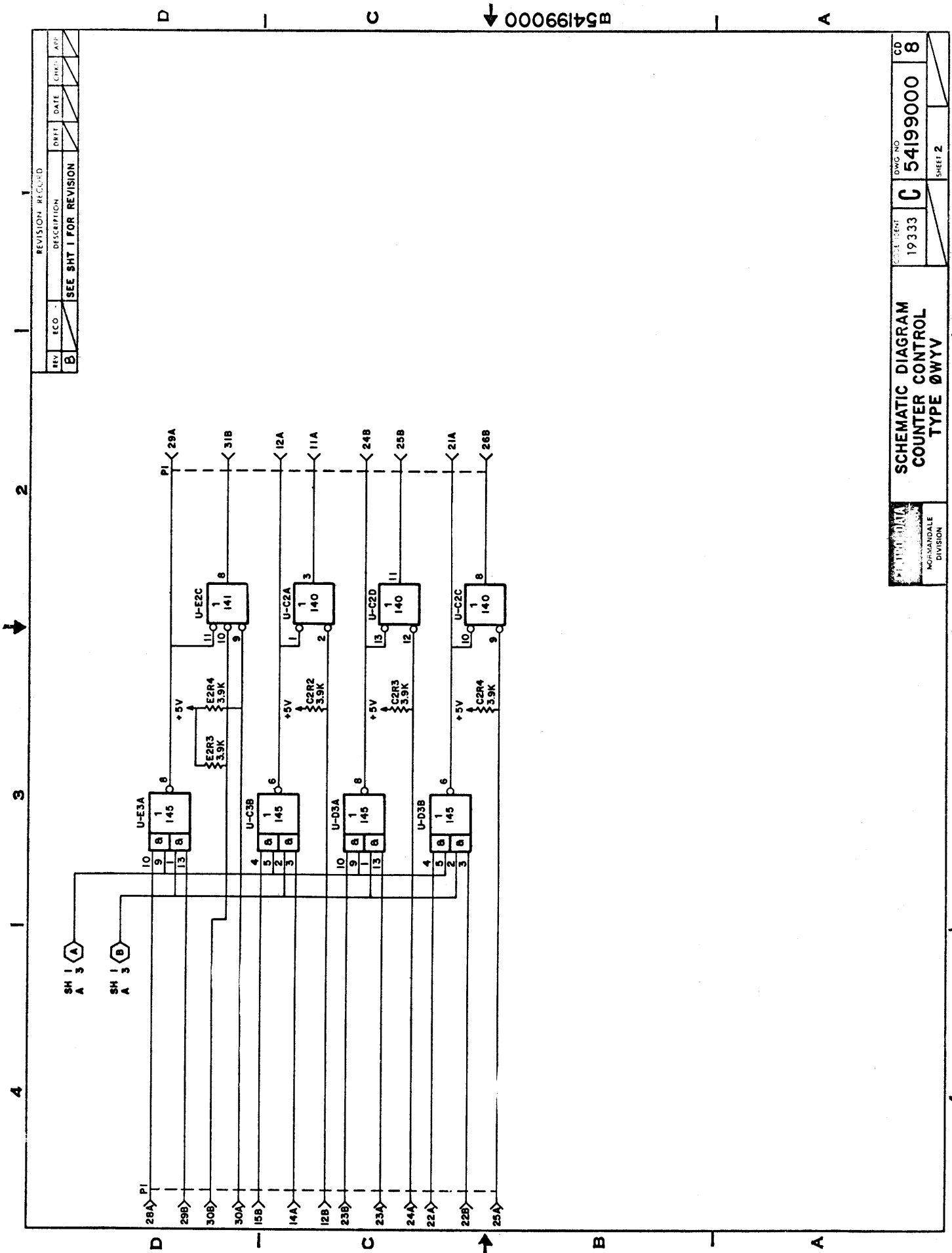

REV	ECO	DESCRIPTION	DATE	CHK'D	APP
B		SEE SHT 1 FOR REVISION			

SCHEMATIC DIAGRAM		CD
COUNTER CONTROL		8
TYPE ØWYV		
DATE	DWG NO	SHEET 2
19333	C 54199000	
MORNINGDALE DIVISION		

B54199000 ↓

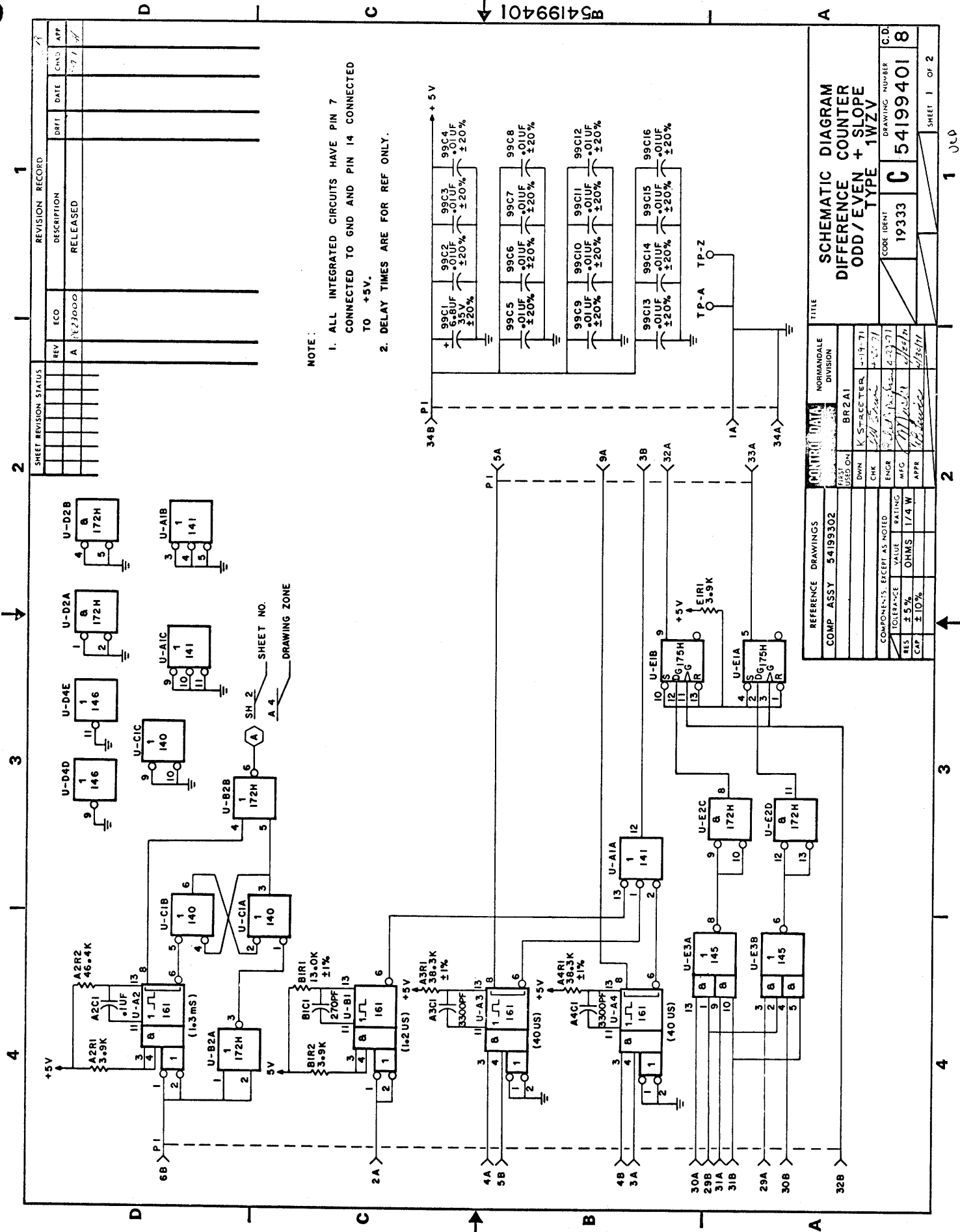

NOTE:
 1. ALL INTEGRATED CIRCUITS HAVE PIN 7 CONNECTED TO GND AND PIN 14 CONNECTED TO +5V.
 2. DELAY TIMES ARE FOR REF ONLY.

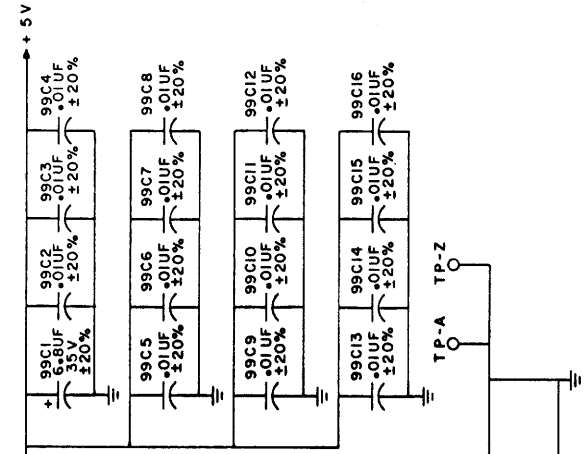

SHEET REVISION STATUS		REVISION RECORD	
REV	ECO	DESCRIPTION	DATE
A	22000	RELEASED	7/1/71

COMP ASSY	54199302	TITLE	NORMANDALE DIVISION
FIRST USED ON	BR 2A1	DRAWING NUMBER	54199401
CHK	K S REETER	DATE	7/1/71
ENGR	DW BROWN	APPR	W B BROWN
MFG	W B BROWN	DATE	7/1/71
RES	W B BROWN	DATE	7/1/71
CAP	W B BROWN	DATE	7/1/71

REFERENCE DRAWINGS		TITLE	
COMP ASSY	54199302	NORMANDALE DIVISION	
FIRST USED ON	BR 2A1	DRAWING NUMBER	54199401
CHK	K S REETER	DATE	7/1/71
ENGR	DW BROWN	APPR	W B BROWN
MFG	W B BROWN	DATE	7/1/71
RES	W B BROWN	DATE	7/1/71
CAP	W B BROWN	DATE	7/1/71

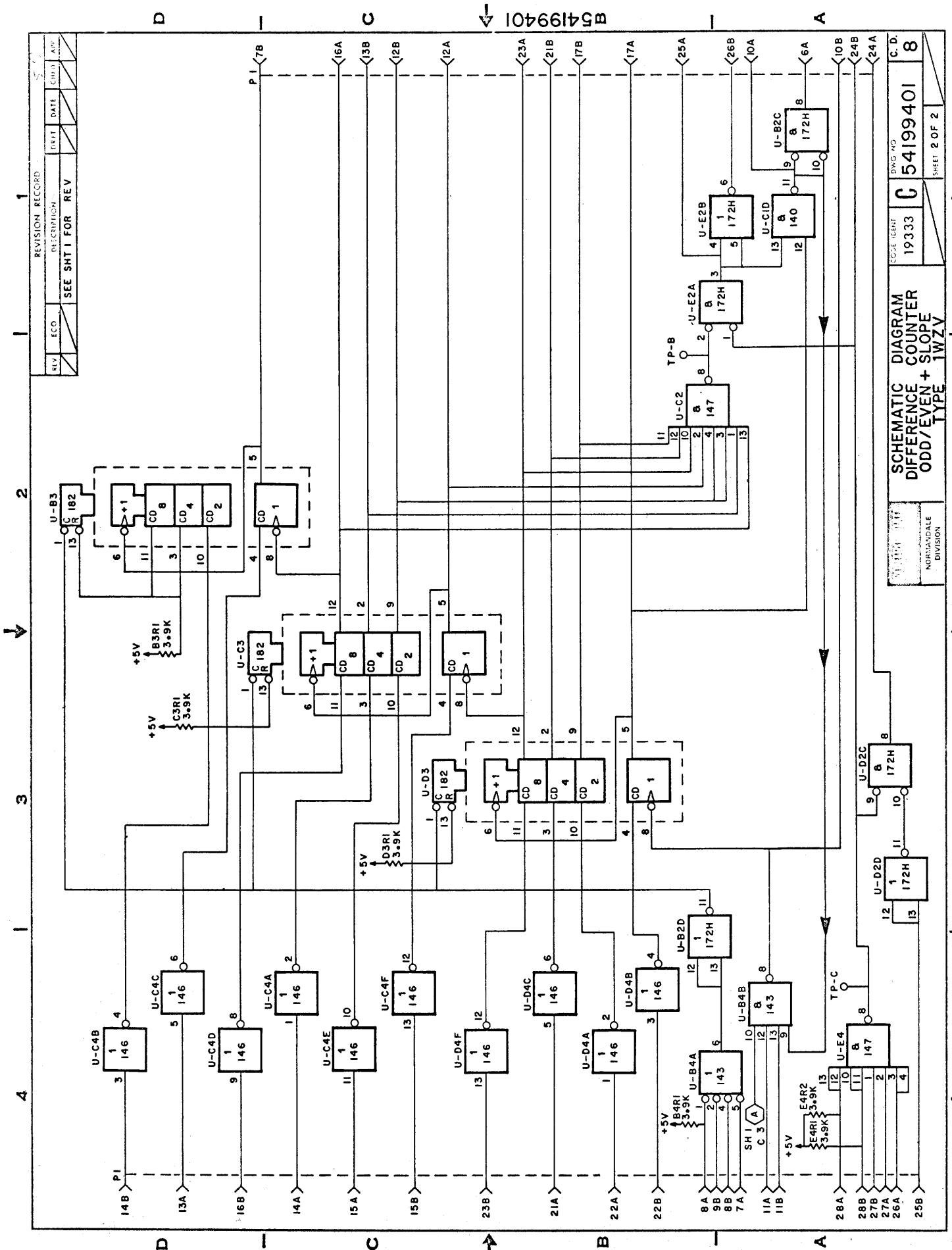

REV	ECO	DESCRIPTION	DATE	CHKD	APP
		SEE SHT 1 FOR REV			

REVISION RECORD

SCHEMATIC DIAGRAM		DWG NO	C.D.
DIFFERENCE COUNTER		54199401	8
ODD/EVEN + SLOPE		19333	
TYPE 1WZV			
ADVISABLE DIVISION			
		SHEET 2 OF 2	

54199401

PART 3

HEAD AND DISK PACK
REPLACEMENT CRITERIA

HEAD AND DISK PACK REPLACEMENT CRITERIA

HEAD REPLACEMENT CRITERIA

Heads of the DSU have been designed so that they should not need replacement if given proper preventive maintenance and care. If a head requires replacement refer to the Preface of this manual for the publication containing the Maintenance section. Refer to that section for Head/Arm Replacement procedure. A head is defective and needs replacing if any of the following conditions exist:

1. Consistent oxide buildup on head indicating repeated head/disk impact.
2. Appreciable oxide buildup located primarily on the edge of the ferrite insert, indicating a warped head.
3. Oxide or wear over 1/2 of the head face surface.
4. A head which is scratched over 1/2 of the head face surface.
5. Concentric scratches on disk surface. Inspect the head for imbedded particles.
6. Audible ping indicating that the head is hitting the disk surface.

DISK PACK REPLACEMENT CRITERIA

The disk pack is designed to last the lifetime of the equipment. Replacement of the disk pack is required only if excessive runout (see Disk Pack Runout Check) is encountered or physical damage to the pack results in the loss of recording ability.

A disk pack is defective and needs replacement if any of the following conditions exist:

1. Damage to the disk pack resulting in a bent or broken disk. If a disk is bent perform Disk Pack Runout Check procedure.
2. Gouged or scored disk surface causing the loss of stored data.
3. Imbedded particles in a disk surface that cannot be removed by cleaning and are causing damage to the heads.

Disk Pack Runout Check

This procedure determines whether a bent disk pack may remain in use. If the disk pack fails to meet the requirements of the procedure, it should be returned to the manufacturer for reconditioning.

1. Open cabinet top cover.
2. Install the disk pack to be checked on a DSU spindle.
3. Grasp the pack cleaning brushes, override the shaft detent mechanism, and rotate the brushes into the disk pack.
4. Place the disk pack runout gage (P/N 84357600) base on the DSU deck base plate (Figure 7-70) adjacent to disk cleaner cutout in shroud.
5. Turn the bezel of the dial indicator to indicate zero. Orient the dial indicator so that the plastic tip is not only contacting a disk surface but is deflected for an indication of approximately 0.020 inch. Tighten dial indicator in this position. Turn the bezel to set the dial indicator to zero.

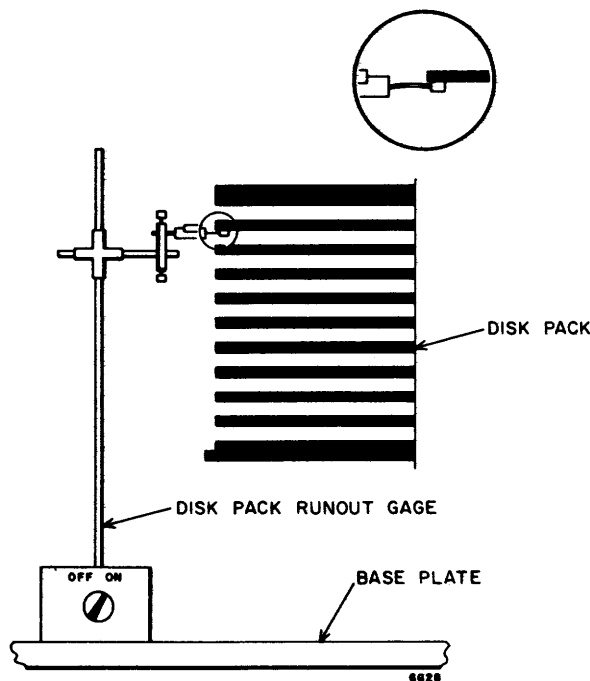

Figure 7-70. Disk Pack Runout Check

NOTE

A mirror is required to observe dial indicator when some disk surfaces are checked.

6. Manually and slowly rotate the disk pack one full revolution while carefully observing the dial indicator. The sum of the deviations (to either side of zero) should not exceed 0.012 inch.
7. If a total deflection of 0.012 inch is encountered in step 6, recheck the indication. The total deflection must occur in a disk circumference of 4 inches or more.
8. Repeat steps 5 through 7 for the 19 remaining disk surfaces.
9. Rotate the pack cleaning brushes clear of the disk surfaces.
10. Remove the disk pack and the disk pack runout gage.

ACCESS TESTER CARD

The access tester card (p/n 54116100) is a special tool used optionally with some DSU's to perform off line maintenance procedures of Section 6. Figure 7-71 is the logic drawing for the card and is provided as an aid in using the tester. Erroneous and/or misleading positioning of the actuator will occur if the tester is not used as specified in the Operation paragraph.

OPERATION

The access tester card allows DSU positioning to be performed in one of two basic modes: repeat (continuous, alternate forward and reverse seeks between a specified pair of tracks) and incremental (sequential seeks of a specified length to the forward limit, returning to zero, and repeating). The desired mode is selected in accordance with the setting of the IN/RP (incremental/repeat) switch, S4. Operation in either mode is controlled by the R/S (run/stop) switch, S3, and the ST (start) switch, S1. A single step modification of the two basic modes may also be performed.

Repeat Mode (Figure 7-72)

To exercise a DSU in the repeat mode, perform following procedure:

1. Set DSU logic chassis maintenance panel ON LINE/OFF LINE switch to OFF LINE and set DC switch to OFF.
2. Install access tester card in DSU logic chassis location C30.
3. Set DC switch to ON.
4. Install disk pack on DSU spindle.
5. Start spindle motor and allow brush cycle to end.
6. Press tester RT (return to zero) switch, S2. DSU should load heads and return to track 0.
7. Set tester IN/RP switch to RP position (repeat).
8. Set tester R/S switch to R position (run).
9. Set tester FWD switches to binary equivalent of the higher valid track desired during the seek. (Example: To select track 100, set FWD switches 64, 32, and 4 to 1. Set other switches to 0).
10. Set tester REV switches to binary equivalent of the lower valid track desired during the seek. (Example: To select track 10, set REV switches 8 and 2 to 1. Set other switches to 0).

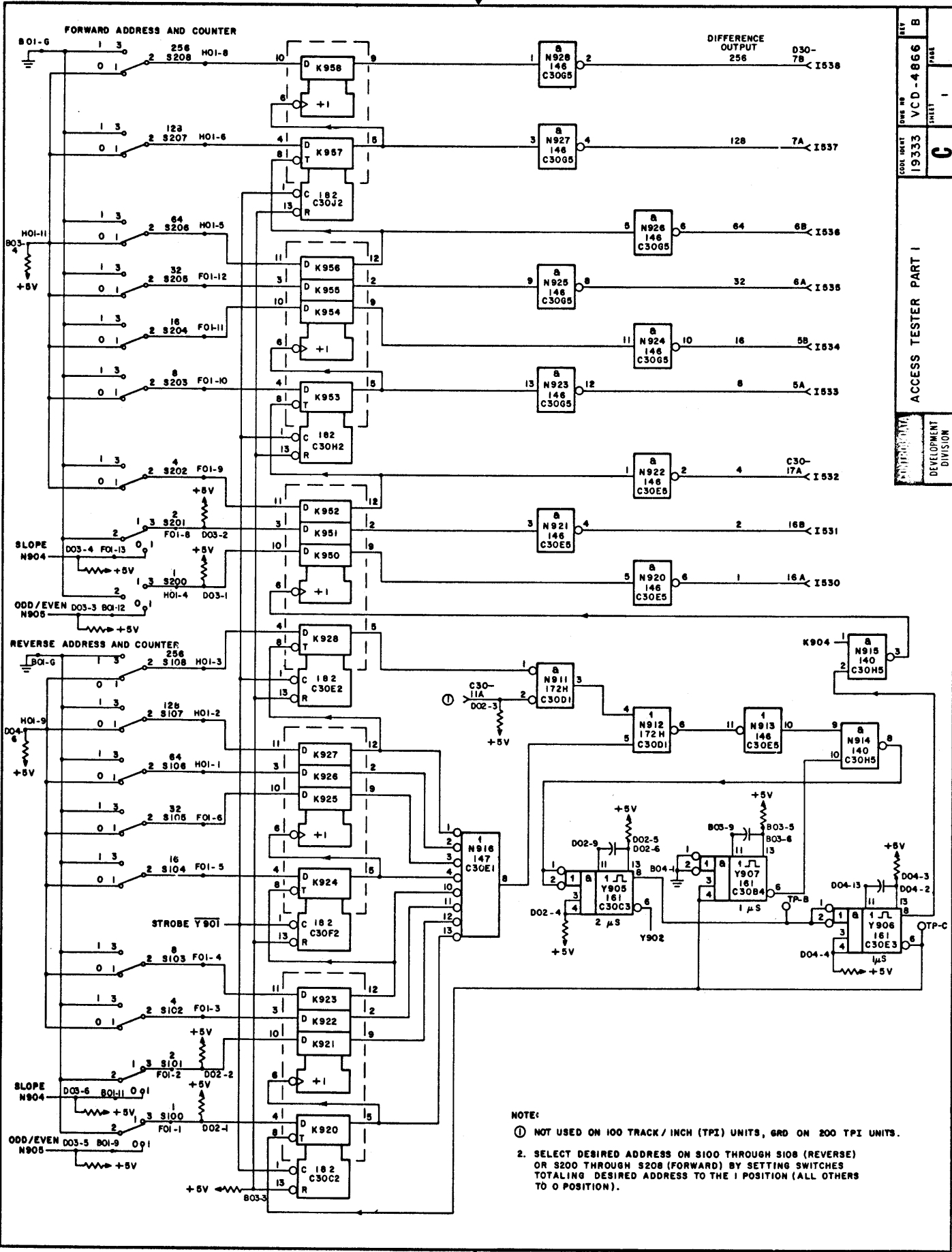

NOTE:
 ① NOT USED ON 100 TRACK / INCH (TPI) UNITS, GRD ON 200 TPI UNITS.
 2. SELECT DESIRED ADDRESS ON S100 THROUGH S108 (REVERSE) OR S200 THROUGH S208 (FORWARD) BY SETTING SWITCHES TOTALING DESIRED ADDRESS TO THE 1 POSITION (ALL OTHERS TO 0 POSITION).

Figure 7-71. Access Tester Card Logic - (Sheet 1 of 2)

REPEAT SEEK (CYLINDER 4 TO CYLINDER 2)

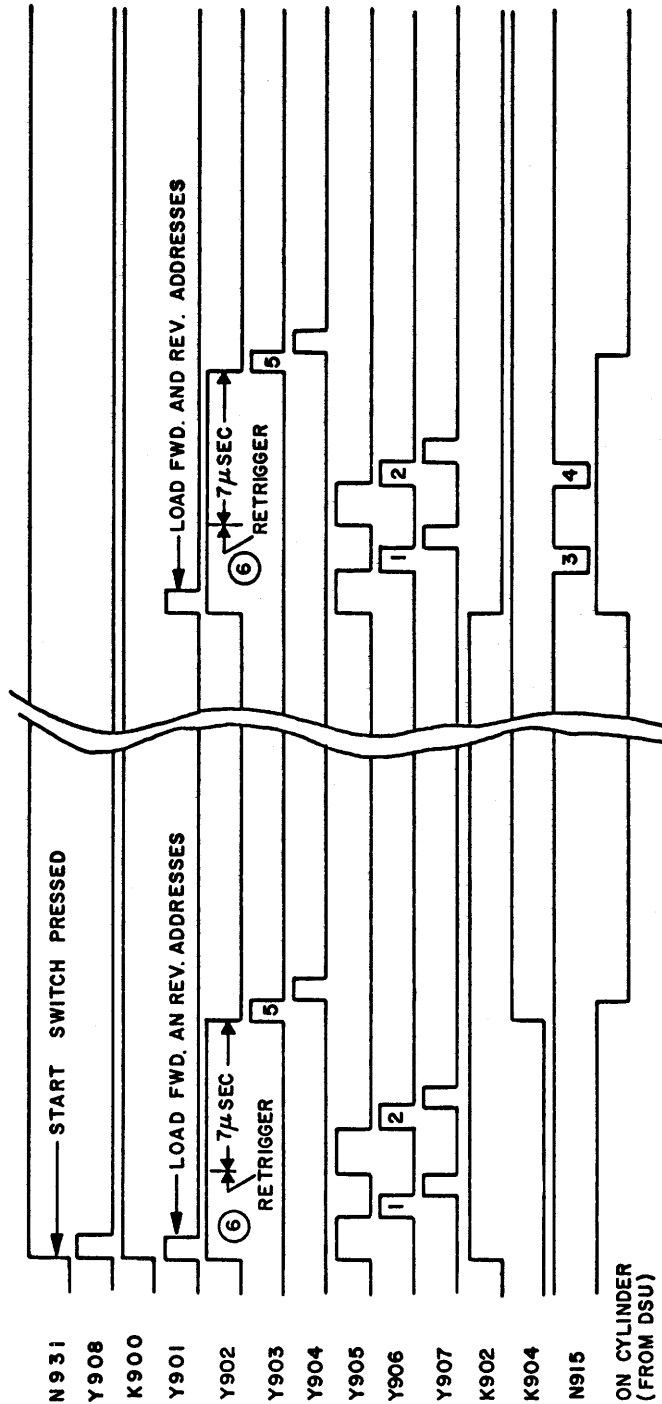

1. INCREMENT REVERSE COUNTER CONTENT 11111101 → 11111110
2. " " " 11111110 → 11111111
3. INCREMENT FORWARD " " 11111101 → 11111100
4. " " " 11111100 → 11111101
5. DELIVER DIFFERENCE FROM FORWARD COUNTER TO DSU DIFFERENCE COUNTER.
- ⑥ Y902 RETRIGGERED BY Y905 EVERY 4 μSEC UNTIL REVERSE COUNTER IS INCREMENTED TO ALL ONES.

6T175

Figure 7-72. Repeat Mode Timing

11. Press tester ST switch.
12. The DSU should now seek forward to the track specified by the FWD switches, generate an On Cylinder signal, seek in reverse to the track specified by the REV switches, and generate an On Cylinder signal.
13. The activities of step 12 will continue until either the tester RT switch is pressed or the R/S switch is set to the S position (stop).
14. Set DSU DC switch to OFF before removing tester card from logic chassis.

Incremental Mode

To exercise a DSU in the incremental mode, perform the following procedure:

1. Set DSU logic chassis maintenance panel ON LINE/OFF LINE switch to OFF LINE and set DC switch to OFF.
2. Install access tester card in DSU logic chassis location C30.
3. Set DC switch to ON.
4. Install disk pack on DSU spindle.
5. Start spindle motor and allow brush cycle to end.
6. Press tester RT (return to zero) switch, S2. DSU should load heads and return to track 0.

NOTE

This procedure is written for a one-track incremental seek. Other, but not all, increments may be selected. Valid selected increments are restricted to those where the FWD switch 1 is set to 1 and the FWD switch 2 is set to 0. Remaining FWD switches (4 through 256) may be set as desired. Settings other than the aforementioned, will result in unpredictable seek activity.

7. Set tester FWD switch 1 to 1.
8. Set all other FWD and REV switches to 0.
9. Set tester IN/RP switch to IN position (incremental).
10. Set tester R/S switch to R position (run).
11. Press tester ST switch.
12. The DSU should now seek forward, one track at a time, until the forward limit is reached, at which time the logic chassis maintenance panel FAULT indicator lights (indicates seek error). To recover from the seek error, the DSU will automatically

return to track 0 and again seek forward, one track at a time.

13. The activities of step 12 will continue until either the tester RT switch is pressed or the R/S switch is set to the S position (stop).
14. Set DSU DC switch to OFF before removing tester card from logic chassis.

Single Step

To exercise a DSU in either a repeat single step mode or an incremental single step mode, perform following procedure:

1. Perform either the procedure for repeat mode operation or the procedure for incremental mode operation, except when the applicable procedure directs positioning of R/S switch, set it to S (instead of R).
2. Now, when the tester ST switch is pressed (step 12 of both procedures), the DSU will perform one seek operation and stop.
3. Press tester ST switch each time a seek operation is desired.

READ/WRITE TESTER CARD

The R/W tester card (p/n 54113701) is a special tool used optionally with some DSU's to perform off line maintenance procedures of Section 6. Figure 7-73 is the logic drawing for the card and is provided as an aid in using the tester.

OPERATION

The R/W tester card allows checkout and diagnosis of the read/write circuits in a DSU.

Write Operation (Figure 7-74)

To write on a DSU disk pack, perform following procedure:

1. Set DSU logic chassis maintenance panel ON LINE/OFF LINE switch to OFF LINE and set DC switch to OFF.
2. Install R/W tester card in DSU logic chassis location C21.
3. Set DC switch to ON.

CAUTION

A CE disk pack contains specially recorded tracks of data. Extreme care must be taken so that this data is not modified. Read or write circuit diagnosis or testing should be done using an unrecorded disk pack or one containing expendable data (scratch pack).

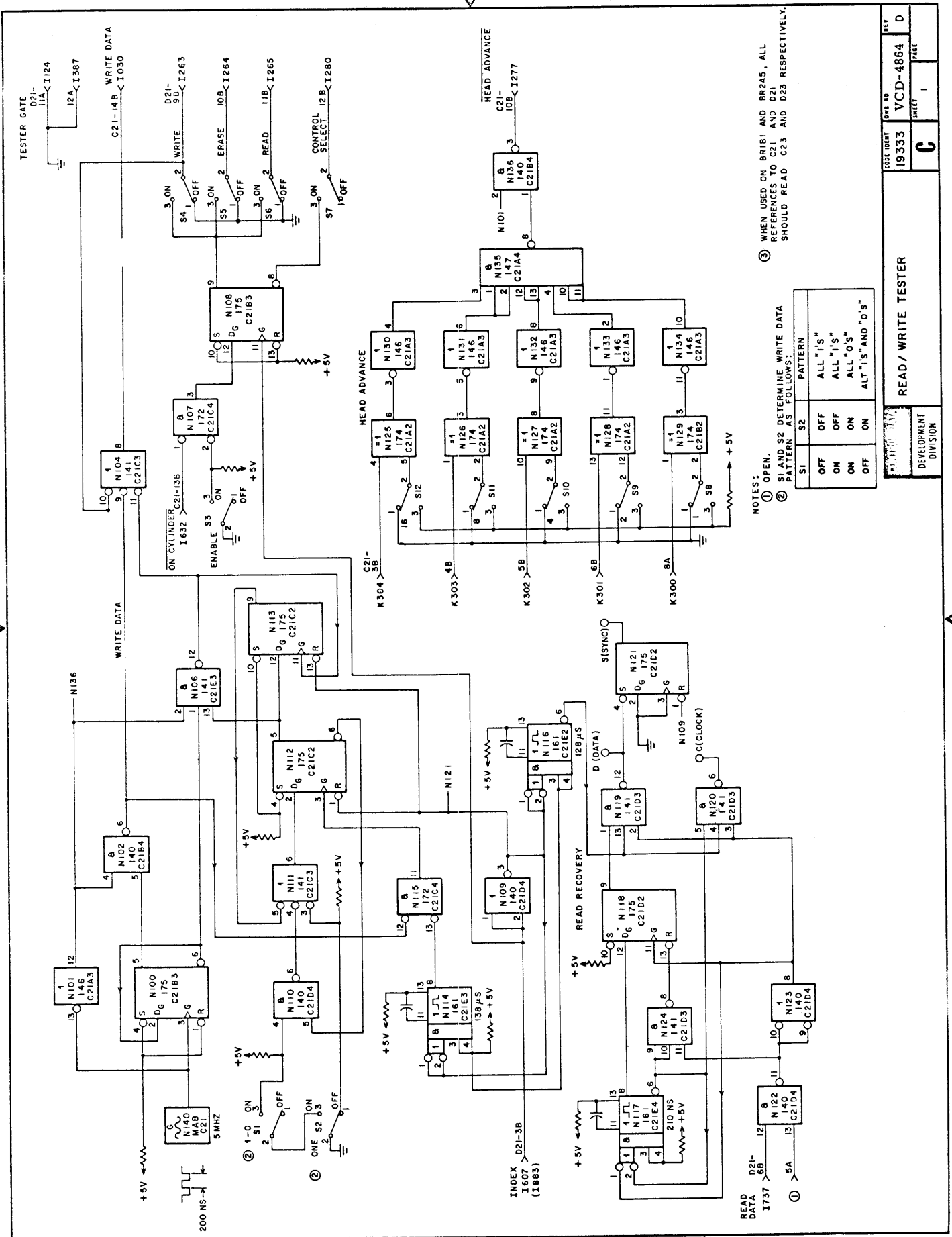

NOTES:
 ① OPEN.
 ② S1 AND S2 DETERMINE WRITE DATA PATTERN AS FOLLOWS:

S1	S2	PATTERN
OFF	OFF	ALL "1'S"
ON	OFF	ALL "1'S"
ON	ON	ALL "0'S"
OFF	ON	ALT "1'S" AND "0'S"

READ / WRITE TESTER

DEVELOPMENT DIVISION

CODE IDENT: 19333

Case no: VCD-4864

REV: D

DATE: _____

Figure 7-73. Read/Write Tester Card Logic

WRITE ALL ZEROS

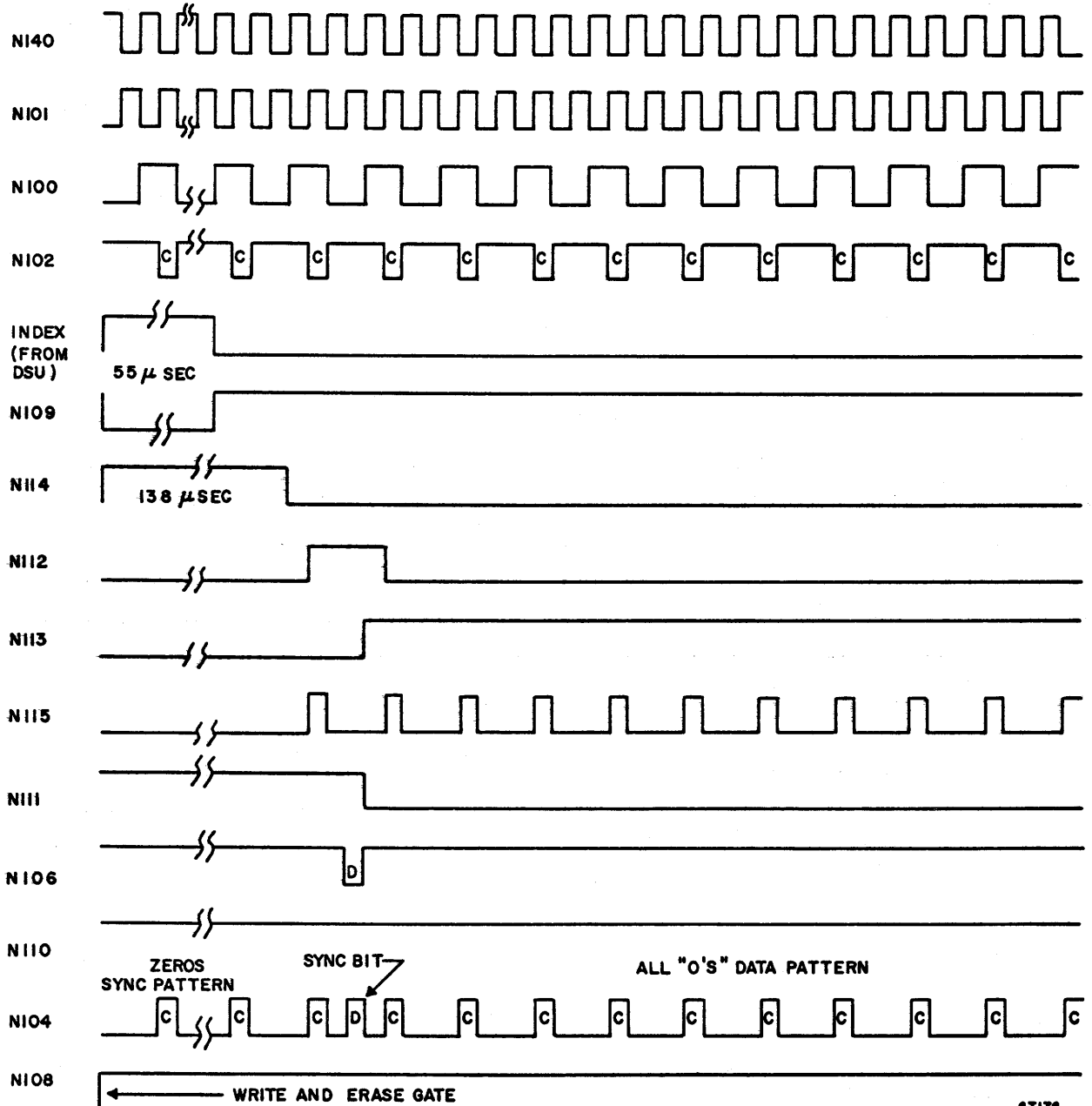

6T176

Figure 7-74. Write Operation Timing - All Zeros

4. Install a scratch pack on DSU spindle.
5. Start spindle motor and allow brush cycle to end.
6. Select desired data pattern to be written by setting tester switches as follows:

Desired pattern	1-0 switch (S1)	ONE switch (S2)
All "1's"	OFF	OFF
All "1's"	ON	OFF
All "0's"	ON	ON
Alternate "1's" and "0's"	OFF	ON

7. Set tester W (write), E (erase), and C-S (control select) switches to ON.
8. Set tester R (read) switch to OFF.
9. Position DSU heads to desired track. (Positioning may be manually, using access tester card, or central processor).
10. Set tester binary switches (1 through 16) representing binary equivalent of desired head to the right. (Example: To select head 11, set switches 8, 2, and 1 to the right. Set switches 4 and 16 to the left).
11. Set tester EN (enable) switch to ON.
12. When the leading edge of Index (Figure 7-74) is sensed, a 138 usec sync pattern of all "0's" is written. This is followed by a single data "1" sync bit and finally the pattern selected by switches S1 and S2 is written until the next leading edge of Index.

NOTE

The positions of the binary switches used to select a head may be changed during a write operation without affecting a read recovery.

13. The activity of step 12 will repeat until one of the following occurs:
 - If W, E, or C-S switch is set to OFF, the write operation will stop immediately
 - If EN switch is set to OFF or a DSU not On Cylinder occurs, the write operation will stop with the next Index pulse.
14. Refer to Read Operation paragraph to recover written pattern.

Read Operation

The tester read recovery circuit is a simple discriminator designed to recover a pattern written during the above described Write Operation. The tester incorporates no checking logic, and pattern verification can be made only by monitoring the D (data) and C (clock) test jacks with an oscilloscope. Use the tester S (sync) test jack to trigger the oscilloscope.

To read from a DSU disk pack, perform the following procedure:

NOTE

Following procedure assumes that tester was installed in DSU logic chassis to write a pattern, and now a read recovery of the pattern is to be performed.

1. Set tester W and E switches to OFF.
2. Set R and C-S switches to ON.
3. Set tester binary switches representing binary equivalent of desired head to the right. (Example: To select head 15, set switches 8, 4, 2, and 1 to the right. Set switch 16 to the left).
4. Set tester EN switch to ON.
5. When the leading edge of Index is sensed, tester generates Read Gate. Tester discriminator circuit then uses the 138-usec "0's" pattern to get in sync. When single-shot N116 times out (noise blanking), the recovered data "1" sync bit sets the Sync FF, N121. Then follows recovered data and clock pulses which the tester separates for monitoring (inverted) at the D and C test jacks.
6. The activity of step 5 will continue until the R, C-S, or EN switch is set to OFF.
7. Set DSU DC switch to OFF before removing tester card from logic chassis.



SECTION 8

PARTS DATA

Information for this section is included in Disk Storage
Unit Parts Data Manual.

SECTION 9

WIRE LISTS

Information for this section is included in Disk Storage
Unit Diagrams, Wire Lists Manual

SECTION 10

EQUATION SUMMARY

(Not Applicable)



COMMENT SHEET

MANUAL TITLE CONTROL DATA DISK STORAGE UNIT
Maintenance Aids

PUBLICATION NO. 70616800 REVISION _____

FROM: NAME: _____
BUSINESS ADDRESS: _____

COMMENTS:

This form is not intended to be used as an order blank. Your evaluation of this manual will be welcomed by Control Data Corporation. Any errors, suggested additions or deletions, or general comments may be made below. Please include page number references and fill in publication revision level as shown by the last entry on the Record of Revision page at the front of the manual. Customer engineers are urged to use the TAR.

CUT ALONG LINE

PRINTED IN U.S.A.

AA3419 REV. 11/99

NO POSTAGE STAMP NECESSARY IF MAILED IN U. S. A.

FOLD ON DOTTED LINES AND STAPLE

STAPLE

STAPLE

FOLD

FOLD

FIRST CLASS
PERMIT NO. 8241
MINNEAPOLIS, MINN.

BUSINESS REPLY MAIL
NO POSTAGE STAMP NECESSARY IF MAILED IN U.S.A.

POSTAGE WILL BE PAID BY
CONTROL DATA CORPORATION
Technical Publications Department
7801 Computer Avenue
Minneapolis, MN 55435

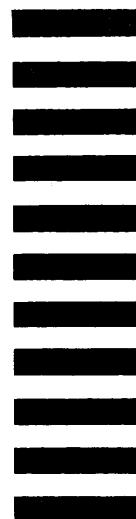

CUT ALONG LINE

FOLD

FOLD

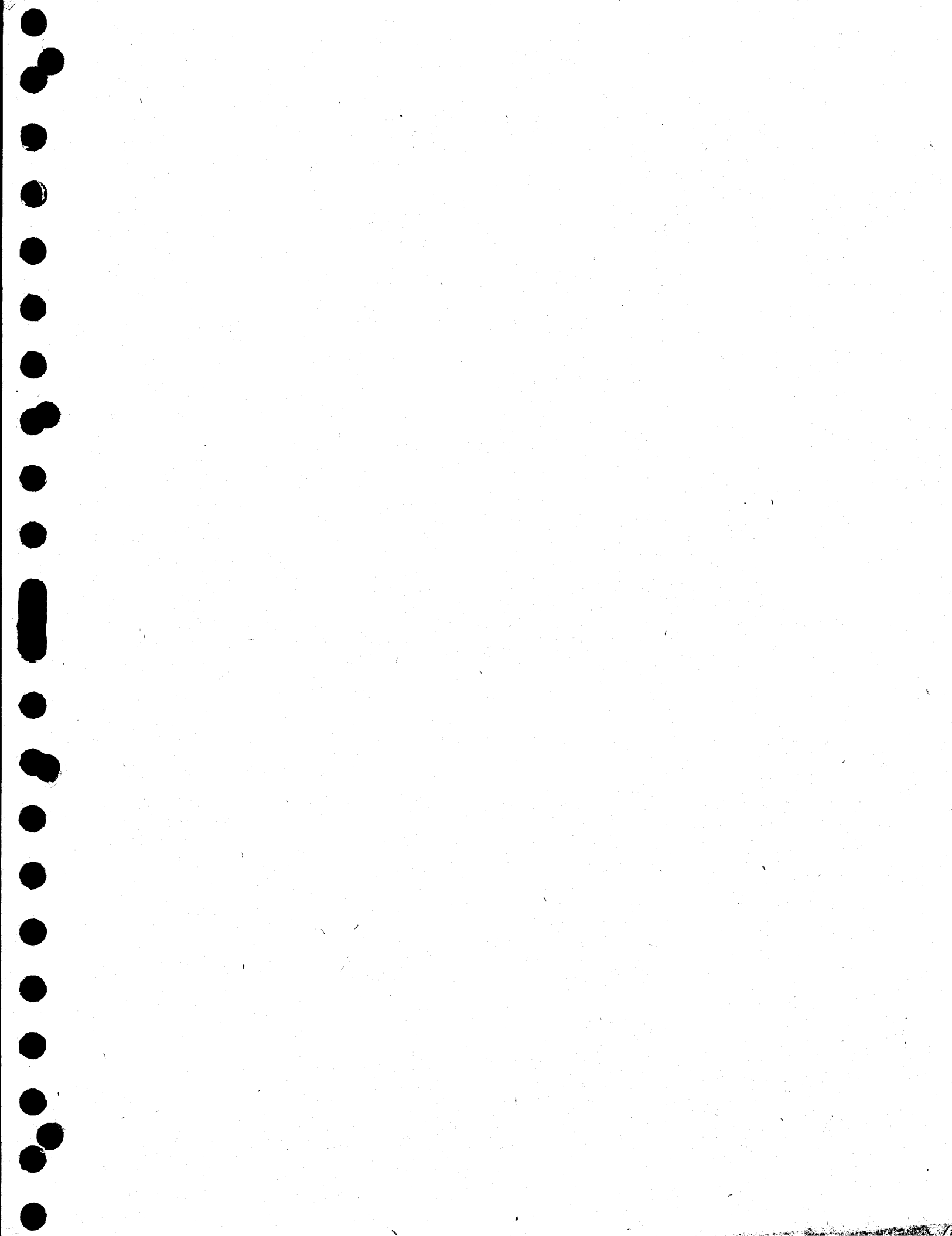

CONTROL DATA

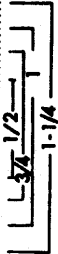

>>> CUT OUT FOR USE AS LOOSE-LEAF BINDER TITLE TAB

CONTROL DATA
CORPORATION

8100 34th AVE. SO., MINNEAPOLIS, MINN. 55440

LITHO IN U.S.A.