

Dansk Data Elektronik A/S

**Technical
Field Change Notes**

Updated 1st November 1996

Copyright © 1990

Dansk Data Elektronik A/S

Copyright © 1990 Dansk Data Elektronik A/S
All Rights Reserved
Printed in Denmark

Stock no.: 93700501

NOTICE

The information in this document is subject to change without notice.

Dansk Data Elektronik A/S, Denmark assumes no responsibility for any errors that may appear in this document.

Permax® is a registered trademark of Dansk Data Elektronik A/S, Denmark.

Table of Contents

SECTION 1.0 : Supermax Field Change Notes

CPU 4700	1
CPU 0100/1	2
CPU 3400	3
CPU 4100/1	4
CPU 4500/1	5
DIOC 0400/1/2	6
DIOC 1100/1	7
DIOC 4000	8
NIOC 1600	9
SECTION 1.1	10

SECTION 1.1 : Supermax Field Change Notes

NIOC 3600	1
SIOC 0300/1	2
SIOC 3600	3
MIOC 4600	4
MIOC 4800	5
MIOC SUBMODULES	6
CIOC 0900/1	7
STATUS	8
OTHERS	9
SECTION 2.0	10

Table of Contents

SECTION 2.0 : Miscellaneous Field Change Notes

NTC 1300	1
NTC2 1310	2
SGD 2500	3
SGD 2510	4
SGD 2600	5
SGD	6
.....	7
.....	8
OTHERS	9
SECTION 3.0	10

SECTION 3.0 : Enterprise/SPC3 Field Change Notes

BAIO301/302	1
MEM301	2
MMD301	3
CPU300/301	4
BMD	5
SCU	6
.....	7
.....	8
OTHERS	9
.....	10

SECTION 3.0

BAIO301/302 1

MEM301 2

MMD301 3

CPU300/301 4

PMD 5

SCU 6

7

8

OTHERS 9

10

SECTION 1.0

CPU 4700 1

CPU 0100/1 2

CPU 3400 3

CPU 4100/1 4

CPU 4500/1 5

DIOC 0400/1/2 6

DIOC 1100/1 7

DIOC 4000 8

NIOC 1600 9

SECTION 1.1 10

Supermax Field Change Notice no. 153

Module:	MCU4700, ISS 2. R4000MCU.
Date:	95-09-19

Category:

- Production change.
- In the field: Never.

Corrects the error:

- The clock signal from the oscillator to the R4400 should not be buffered.

Needed tools:

Hand tools.

Description:

- Shortcircuit pin 12 and pin 13 of H10 (74AS1004) before mounting the component.
- Cut pin 12 and pin 13 on H10 74AS1004 before mounting.

Circuits involved:

Name	Type
H10	74AS1004

Previous FCN:

FCN136

Supermax Field Change Notice no. 136

Module:	MCU4700, ISS 2. R4000MCU. FCN no 1.
Date:	93-09-03

Category:

- Production change.
- In the field: If errors occur.

Corrects the error:

- When the CPU module is connected to 256 Mbyte memory, the self test fails with FF in the display and the Diagnostic Program reports "Error during PROM self test. Fatal error".

Needed tools:

Hand tools.

Supermax FCN kit 136, stock number 95101360, consisting of:

- One EPROM labeled "R4BOOT-0 Vers 1.2 93.08.25"
- One EPROM labeled "R4BOOT-1 Vers 1.2 93.08.25"
- One EPROM labeled "R4BOOT-2 Vers 1.2 93.08.25"
- One EPROM labeled "R4BOOT-3 Vers 1.2 93.08.25"

Description:

- Replace EPROM device F5 with EPROM labeled "R4BOOT-0"
- Replace EPROM device F4 with EPROM labeled "R4BOOT-1"
- Replace EPROM device F3 with EPROM labeled "R4BOOT-2"
- Replace EPROM device F2 with EPROM labeled "R4BOOT-3"

Circuits involved:

Name	Type	Position
F2	EPROM 27512	M9
F3	EPROM 27512	M10
F4	EPROM 27512	M10
F5	EPROM 27512	M11

SUPERMAX FIELD CHANGE NOTICE NO. 71

DATE: 890116

MODULE: 0100/0101 CPU

CATEGORY:

Production change.

In the field:

When errors occur.

When modules are exchanged or installed in systems with 24 positions.

CORRECTS THE ERROR:

The arbitration signals in the Supermax I/O bus are open collector signals, that are driven by all units in the system.

The rise time of these signals is approximately proportional to the number of units in the system.

In a system with 12 positions the rise time is small enough to leave a large margin.

In a system with 24 positions and many units the rise time is larger and a smaller margin remains.

High temperature and low voltage reduces the margin, and errors may occur in large systems. The errors are usually time out errors.

To improve the margin, the rise time is decreased by reducing the pull-up resistors in systems with 24 positions.

The pull-up resistors are reduced by using two sets of pull-up resistors in parallel, one set in each card cage. The pull-up resistors are located on CPU modules and the changes are described in field change notes 71, 72, and 73.

All units in a Supermax system have one or two drivers, that drive the arbitration signals. All drivers in a system must be changed to drive the reduced pull-up resistors.

The necessary changes for all units are described in field change notes 71 - 79.

All units in a system must be updated according to these notes, when the pull-up resistors are reduced as described in field change notes 71, 72, and 73.

A unit, that is updated, may be used in a system where the pull-up resistors are not reduced.

TOOLS NEEDED:

Hand tools.

1 74AS641

1 SIL resistor package type 10X-1-151

DESCRIPTION:

1. Change IC in position C0 from 74ALS641-1 to 74AS641.
2. If CPU 0100, update revision level to F by removing the letter E revision level field.

If CPU 0101, update ASSY revision level to B by removing the letter A in ASSY identification field.

3. In systems with 24 positions:

Install pull-up resistors in position SI25 on one 100/101 CPU module, so two CPU modules have pull up resistors installed, one in each card cage.

SUPERMAX FIELD CHANGE NOTICE NO. 47

DATE: 870527

MODULE: CPU 0100 and 0101

CATEGORY:

Production change.

In the field: To be made when installing Non-Operator Diagnostic Programs.

CORRECTS THE ERROR:

Enables the CPU to activate the reset line in the mother board.

NEEDED TOOLS:

Insulated wire.

DESCRIPTION:

1. Connect J2 pin B-12 to J2 pin C-10.
2. Change revision level to C by removing the letter B in the PCB identification on the component side of the board.

CIRCUITS INVOLVED:

Bus connector J2.

Note: Pin row A in J2 is closest to the mother board.

SUPERMAX FIELD CHANGE NOTICE NO. 24DATE: 850813MODULE: 0101 CPU MODULE.CATEGORY:

PRODUCTION CHANGE.

TO BE MADE AT A SUITABLE OCCASION.

CORRECTS THE ERROR:

Unreliable data transfers over the IO bus in large Supermax systems with two card cabinets.

DESCRIPTION:

The frequency of the BUS CLOCK is changed from 10 MHz to 8 MHz. Clocks are strapped in a strap socket position Z6. The strap socket is found in the upper left corner of the board close to the three crystal oscillators.

Old clock strap position Z6:

10 Mhz	0	0	CPU CLOCK (PIN 16)
12 Mhz	0-----0	0	CPU CLOCK
16 Mhz	0	0	20 Mhz
16 Mhz	0	0	INTERNAL CLOCK
8 Mhz	0	0	BUS CLOCK
6 Mhz	0	0	10 Mhz
8 Mhz	0	0	
10 Mhz	0	0	

New clock strap position Z6:

10 Mhz	0	0	CPU CLOCK (PIN 16)
12 Mhz	0-----0	0	CPU CLOCK
16 Mhz	0	0	20 Mhz
16 Mhz	0	0	INTERNAL CLOCK
8 Mhz	0-----0	0	BUS CLOCK
6 Mhz	0	0	10 Mhz
8 Mhz	0	0	
10 Mhz	0	0	

SUPERMAX FIELD CHANGE NOTICE NO. 19

DATE: 850708

MODULE: CPU MODULE 0101

CATEGORY:

PRODUCTION CHANGE.

IN THE FIELD:
TO BE MADE AT A SUITABLE OCCASION.

CORRECTS THE ERROR:

A single bit error in main memory is not corrected properly,
when the error occurs in a program reference to main memory.

A single bit error in a data reference is corrected properly.

NEEDED TOOLS:

HAND TOOLS.

DESCRIPTION:

Disconnect S1 PIN 3 from the printed circuit board.

Connect S1 PIN 3 to XC PIN 2 using a wire on the component
side of the board.

Update PCB Revision level from A to B by removing the letter A
from the component side of the board.

SUPERMAX FIELD CHANGE NOTICE NO. 17

DATE: 850308

MODULE: 0100 CPU MODULE.

CATEGORY:

PRODUCTION CHANGE.

IN THE FIELD:
TO BE MADE AT A SUITABLE OCCASION.

CORRECTS THE ERROR:

SYSTEM CRASH caused by double fault in main memory.
This crash gives error code 47 in front panel display.

The change increases address set up time to memory modules,
when the memory is accessed from the IO bus.

NEEDED TOOLS:

Hand tools.

DESCRIPTION:

PAL in position F1 is changed from C10 to C11.
PAL in position C1 is changed from C20 to C21.
PAL in position F8 is changed from C60 to C61.

SUPERMAX FIELD CHANGE NOTICE NO. 14

DATE: 841121

MODULE: 0100 CPU MODULE. SINGLE CPU SYSTEMS.CATEGORY:

PRODUCTION CHANGE.

TO BE MADE AT A SUITABLE OCCASION.

TO BE MADE WHEN A SYSTEM IS EXPANDED.

CORRECTS THE ERROR:

Clock strap used in single CPU systems:

6 Mhz	0	0	CPU CLOCK (PIN 16)
8 Mhz	0	0	CPU CLOCK
10 Mhz	0-----0	0	CPU CLOCK
10 Mhz	0-----0	0	BUS CLOCK
12 Mhz	0	0	BUS CLOCK
16 Mhz	0	0	BUS CLOCK
16 Mhz	0-----0	0	INTERNAL CLOCK
20 Mhz	0	0	INTERNAL CLOCK

Pin 3 and pin 4 in the clock strap is driven by the same clock driver. When the clock in the IO bus is heavily loaded, the waveform on the clock pin of the 68000 is unacceptable. Because of this error the clock strap must be changed to:

6 Mhz	0	0	CPU CLOCK (PIN 16)
8 Mhz	0---}	0	CPU CLOCK
10 Mhz	0---}	0	CPU CLOCK
10 Mhz	0---}	0	BUS CLOCK
12 Mhz	0	0	BUS CLOCK
16 Mhz	0	0	BUS CLOCK
16 Mhz	0-----0	0	INTERNAL CLOCK
20 Mhz	0	0	INTERNAL CLOCK

This clock strap has always been used in multi CPU systems.

SUPERMAX FIELD CHANGE NOTICE NO. 9

DATE: 840924

MODULE: 0100 C SUPERMAX CPU MODULE.

CATEGORY:

PRODUCTION CHANGE.

IN THE FIELD: TO BE MADE AT A SUITABLE OCCASION.

CORRECTS THE ERROR:

To run test programs in the CPU module from the SERVICE PORT it is necessary to change the interrupt strap on the module.

NEEDED TOOLS:

Hand tools.

DESCRIPTION:

Connect Z5-06 to Z5-10, interrupt strap. Interrrupt from the SERVICE PORT is strapped to interrupt level 1.

Disconnect X6-10 from the PCB by cutting the pin. Transmitter interrupt from the SERVICE PORT is disconnected.

Update revision level from C to D by removing the letter C on the component side of the board.

CIRCUITS INVOLVED:

Interrupts from the SERVICE PORT.

SUPERMAX FIELD CHANGE NOTICE NO. 7

DATE: 840227 KAN

MODULE: 0100 C SUPERMAX CPU MODULE.

CATEGORY:

PRODUCTION CHANGE.
TO BE MADE WHEN ERROR OCCURS.

CORRECTS THE ERROR:

Power up RESET pulse too short.
RESET pulse generated by KEY sufficiently long.

NEEDED TOOLS:

Hand tools.

Resistor 22 Kohm

Tantal capacitor 22uF/16v. Distance between pins: 2.54 mm.

DESCRIPTION:

Change resistor RE7 from 10 Kohm to 22 Kohm.
Change tantal capacitor CA4 from 6.8 uF/25 v to 22 uF/16v

CIRCUITS INVOLVED:

Power up reset

SUPERMAX FIELD CHANGE NOTICE NO. 3

DATE: 831014.

MODULE: 0100B CPU MODULE

CATEGORY:

TO BE MADE WITHOUT ANY UNNECESSARY DELAY.

CORRECTS THE ERROR:

SYSTEM CRASH ERROR CODE 14.

PROBABILITY OF OCCURRENCE PROPORTIONAL TO THE SQUARE
OF THE CPU WORK LOAD.

NEEDED TOOLS:

HAND TOOLS. INSULATED WIRE. PAL MARKED C151.

DESCRIPTION:

1. REPLACE PAL MARKED C150 WITH PAL MARKED C151.
2. DISCONNECT Y7-09 BY CUTTING WIRE ON SOLDER SIDE CLOSE TO THE PIN.
3. CONNECT Y7-09 TO C4-11.
4. DISCONNECT R9-12 BY CUTTING WIRE ON SOLDER SIDE CLOSE TO THE PIN.
5. CONNECT R9-12 TO N0-12.
6. UPDATE REVISION LEVEL FROM 0100B TO 0100C BY REMOVING THE LETTER
B ON COMPONENT SIDE.

CIRCUITS INVOLVED:

NAME	TYPE	POSITION
Y7	74S08	A 6,1
C4	74ALS573	A 7,1
R9	74LS74	B 3,6
N0	PAL C151	B 5,4

SUPERMAX FIELD CHANGE NOTICE NO. 1

DATE: 830507 KAN

MODULE: 0100A CPU MODULE

CATEGORY:

TO BE MADE WITHOUT ANY DELAY AT ALL.

CORRECTS THE ERROR:

SPURIOUS INTERRUPT.

NEEDED TOOLS:

HAND TOOLS. INSULATED WIRE.

DESCRIPTION:

1. Cut the connection to Y0-05 on the solder side of the board.
2. Connect Y0-05 to Z1-12 on the solder side using insulated wire.
3. Change revision level from 0100A to 0100B by removing the letter A in the PC identification on the component side of the board.

CIRCUITS INVOLVED:

Name	Type	Position
Y0	74S20	B 8,6
Z1	74S04	B 7,7

SUPERMAX FIELD CHANGE NOTICE NO. 72

DATE: 890116

MODULE: 3400 CPU

CATEGORY:

Production change.

In the field:

When errors occur.

When modules are exchanged or installed in systems with 24 positions.

CORRECTS THE ERROR:

The arbitration signals in the Supermax I/O bus are open collector signals, that are driven by all units in the system.

The rise time of these signals is approximately proportional to the number of units in the system.

In a system with 12 positions the rise time is small enough to leave a large margin.

In a system with 24 positions and many units the rise time is larger and a smaller margin remains.

High temperature and low voltage reduces the margin, and errors may occur in large systems. The errors are usually time out errors.

To improve the margin, the rise time is decreased by reducing the pull-up resistors in systems with 24 positions.

The pull-up resistors are reduced by using two sets of pull-up resistors in parallel, one set in each card cage. The pull-up resistors are located on CPU modules and the changes are described in field change notes 71, 72, and 73.

All units in a Supermax system have one or two drivers, that drive the arbitration signals. All drivers in a system must be changed to drive the reduced pull-up resistors.

The necessary changes for all units are described in field change notes 71 - 79.

All units in a system must be updated according to these notes, when the pull-up resistors are reduced as described in field change notes 71, 72, and 73.

A unit, that is updated, may be used in a system where the pull-up resistors are not reduced.

TOOLS NEEDED:

Hand tools.

1 74AS641

DESCRIPTION:

1. Change IC in position Z3 from 74ALS641-1 to 74AS641.
2. Update ASSY revision level to F by removing the letter E in ASSY identification field.
3. In systems with 24 positions:

Turn all bits in switch Z10 on, on one CPU module, to add an extra set of pull up resistors.

Make sure that two CPU modules have switch Z10 turned on, one in each card cage.

SUPERMAX FIELD CHANGE NOTICE NO. 66

DATE: 881123

MODULE: CPU 3400

CATEGORY:

Production change.

In the field: To be made at a suitable occasion.

CORRECTS THE ERROR:

There is a possibility that the module changes the unit number during the last clock cycle of an access to the I/O bus. If that happens, it may cause an error in another unit connected to the I/O bus.

TOOLS NEEDED:

Hand tools.

DESCRIPTION:

1. Disconnect M6 pin 23 by cutting the wire from M6 pin 23 to M6 pin 2 on the solder side of the board.
2. Connect M6 pin 23 to Z2 pin 15 by a wire on the solder side of the board.
5. Update PCB revision level C to D by removing the letter C.

SUPERMAX FIELD CHANGE NOTICE NO. 57

DATE: 880711

MODULE: CPU 3400.

CATEGORY:

Production change.

CORRECTS THE ERROR:

Problems during an access to the IO bus if:

1. The processor MC68020 is running at 25 MHz.
2. A program running in user mode violates the memory protection.

TOOLS NEEDED:

Hand tools.
PAL C2P147.

DESCRIPTION:

1. Change PAL in position X4 to C2P147.
 2. Update ASSY revision level from D to E by removing the letter D.
-

SUPERMAX FIELD CHANGE NOTICE NO. 55

DATE: 880615

MODULE: CPU 3400.

CATEGORY:

Production change.

In the Field: To be made when error occurs.

This note replaces note #53.

CORRECTS THE ERROR:

"error corrected. Syndrome bits not valid."

The error may be seen when the CPU is running the memory test program at a high voltage level. (5.25 v).

The flip flop that samples the error signal from the ECC circuitry is set even if there is no error in memory. This setting is caused by very high dV/dt on the data input to the flip flop.

The memory control executes an error correcting cycle, when the flip flop has been set, but because there is no error in memory the syndrome bits are either set to 7F (no error) or not set at all.

The cure is to increase the rise time on the data inputs to the flip flop.

NEEDED TOOLS: Hand tools.

DESCRIPTION:

If ASSY revision level is B then

1. Connect a 270 pF capacitor between pin 2 and pin 7 on C7.
2. Connect a 270 pF capacitor between pin 6 and pin 7 on C8.

3. Update ASSY revision level from B to D by removing the letters B and C.

If ASSY revision level is C then

1. Disconnect the 10 pF capacitor between pin 2 and pin 3 on C8.
 2. Connect a 270 pF capacitor between pin 2 and pin 7 on C7.
 3. Connect a 270 pF capacitor between pin 6 and pin 7 on C8.
 3. Update ASSY revision level from C to D by removing the letter C.
-

SUPERMAX FIELD CHANGE NOTICE NO. 54

DATE: 880201

MODULE: CPU 3400

CATEGORY:

Production change.

In the field: To be made when error occurs.

CORRECTS THE ERROR:

Mismatch between read and write data when running the bustest program. The bustest program is a part of Supermax diagnostic programs.

TOOLS NEEDED:

Hand tools.
Insulated wire.
2 x 75F74.
1 x PAL C2P132.

DESCRIPTION:

1. PAL in position X3 is changed to C2P132.
2. Disconnect Z5 pin 4 by cutting the pin near the PCB.
3. Connect Z5 pin 4 to Z6 pin 5 with insulated wire on the component side of the PCB.
4. Disconnect B9 pin 11 by cutting the pin near the PCB.

5. Connect B9 pin 11 to A16 pin 8 with insulated wire on the component side of the PCB.
6. Connect A16 pin 9 to C12 pin 10 with insulated wire on the component side of the PCB.
7. Change the PCB revision level to C by removing the letter B in the PCB identification on the component side of the board.

SUPERMAX FIELD CHANGE NOTICE NO. 53DATE: 880201MODULE: CPU 3400.CATEGORY:

Production change.

In the Field: To be made when error occurs.

CORRECTS THE ERROR:

"error corrected. Syndrome bits not valid."

The error may be seen when the CPU is running the memory test program at a high voltage level. (5.25 v).

The flip flop that samples the error signal from the ECC circuitry is set even if there is no error in memory. This setting is caused by very high dV/dt on the data input to the flip flop.

The memory control executes an error correcting cycle, when the flip flop has been set, but because there is no error in memory the syndrome bits are either set to 7F (no error) or not set at all.

The cure is to increase the rise time on the data input to the flip flop.

NEEDED TOOLS: Hand tools.DESCRIPTION:

1. Connect a 10 pF capacitor between pin 2 and pin 3 on C8.
 2. Update ASSY revision level from B to C by removing the letter B.
-

SUPERMAX FIELD CHANGE NOTICE NO. 48DATE: 870624MODULE: CPU 3400CATEGORY:

PRODUCTION CHANGE

CORRECTS THE ERROR:

If the clock frequency for the 68020 is increased to 25 MHz bad data is written in the data cache under certain circumstances.

DESCRIPTION:

PAL in position C1 is changed from CP53 to CP56.

SUPERMAX FIELD CHANGE NOTICE NO. 43

DATE: 870501

MODULE: CPU 3400

CATEGORY:

Production change.

In the field: To be made when error occurs.
To be made at a suitable occasion.

CORRECTS THE ERROR:

Seen from the user the system is down.
One or more io-controllers detects a time-out cycle on the
supermax io bus and stops execution.

The error occurs some times when a user program generates an
illegal address.

NEEDED TOOLS:

Hand tools.
PAL c2p43.

DESCRIPTION:

1. Connect W1 pin 23 to W3 pin 23 with insulated wire on the
solder side on the board.
2. Change PAL package W1 from c2p42 to c2p43.
3. Change revision level to B by removing the letter A in the
PCB identification on the component side of the board.

CIRCUITS INVOLVED:

Name Type

W1 PAL c2p42 / c2p43

W3 PAL c2p60

SUPERMAX FIELD CHANGE NOTICE NO. 42DATE: 870428MODULE: CPU 3400CATEGORY:

. PRODUCTION CHANGE

CORRECTS THE ERROR:

Increases the margin for generation of check bits during byte write operations.

DESCRIPTION:

PAL in position F4 is changed from CP120 to CP123 or from CP170 to CP173.

Supermax Field Change Notice no. 106

Module: CPU 4100 and 4101, ISS 0.

Date: 92.01.30

Category:

- Production change.
- In the field: To be made without any unnecessary delay.

Corrects the error:

- The error results in system crash, display code 00, 02 and 87 with the Supermax Operating System.

Needed tools:

Hand tools.

Supermax FCN kit 106, stock number 95101060, consisting of:

1. One PAL labeled "C3001"
2. One PAL labeled "C3101"
3. One PAL labeled "C3033"

Description:

1. Replace PAL C3000 with C3001.
2. Replace PAL C3100 with C3101.
3. Replace PAL C3032 with C3033.
4. Update ASSY revision field: Update to revision J by removing the letter I in the ASSY identification field.

Circuits involved:

Name	Type	Position
R4	C3000	L10
R3	C3100	L11
X3	C3032	L9

Supermax Field Change Notice no. 103

Module: CPU 4100 and 4101, ISS 0.

Date: 91.06.01

Category:

- Production change.
- In the field: To be made without any unnecessary delay.

Corrects the error:

- The error is seen, when using the Supermax Diagnostics bus test program as a bus time-out.
- The error results in system crash, display code 00, with the Supermax Operating System.

Needed tools:

Hand tools.

Supermax FCN kit 103, stock number 95101030, consisting of:

1. One PAL labeled "C3272"

Description:

1. Replace PAL C3271 with C3272.
2. Update ASSY revision field: Update to revision I by removing the letter H in the ASSY identification field.

Circuits involved:

Name	Type	Position
B11	C3271	B14

Supermax Field Change Notice no. 98

Module:	CPU 4100 and 4101, ISS 0.
Date:	91.02.26

Category:

- Production change.
- In the field: To be made without any unnecessary delay.

Corrects the error:

- A PAL device does not comply with its AC specification. The PAL is replaced with a different type.
- The error results in unpredictable errors, system crash, core dumped or trace files with the Supermax Operating System.
- The error is seen as memory errors with the Supermax Diagnostic programs. Worst case environment is high supply voltage and high temperature.

Needed tools:

Hand tools.

Supermax FCN kit 098, stock number 95100980, consisting of:

1. One PAL labeled "C3361".

Description:

1. Change PAL C3360 to C3361.
2. Update ASSY revision field: Update to revision H by removing the letter G in the ASSY identification field.

Circuits involved:

Name	Type	Position
E4	C3360	D10

Supermax Field Change Notice no. 96

Module:	CPU 4100 and 4101, ISS 0.
Date:	91.01.08

Category:

- Production change.
- In the field: Before Supermax operating system 530.5N (or later version) is installed.

Corrects the error:

- The 530.5N operating system use broadcast write cycles. The broadcast cycles are not working correctly due to an wired-or glitch.
- The error results in unpredictable errors, system crash or system hang-up with the Supermax Operating System.

Needed tools:

Hand tools.

Supermax FCN kit 096, stock number 95100960, consisting of:

1. One resistor, 330 ohm.

Description:

1. Change resistor WR1 from 100 to 330 ohm.
2. Update ASSY revision field: Update to revision G by removing the letter F in the ASSY identification field.

Circuits involved:

Name	Type	Position
WR1	Resistor	K5

Resistor WR1 is located near Unit number switch U7 and single inline resistor network US1.

Supermax Field Change Notice no. 93

Module:	CPU 4100 and 4101, ISS 0.
Date:	90.10.05

Category:

- Production change.
- In the field: Before Supermax operating system 530.5N is installed.

Corrects the error:

- The 530.5N operating system use broadcast write cycles. This new facility is not working correctly due to an error in SRAM type CY7C164-25PC.
- The error results in unpredictable errors or system crash with the Supermax operating system.

Needed tools:

Hand tools.

Supermax FCN kit 093, stock number 95100930, consisting of:

1. Four SRAM's.

Description:

1. If SRAM M15, M16, M17 or M18 is a CY7C164 type then replace the four SRAM's with SRAM's from the FCN kit.
2. Update ASSY revision field:
 - Update to revision F by removing the letter E in the ASSY identification field.

Circuits involved:

Name	Type	Position
M15	SRAM	M6
M16	SRAM	M7
M17	SRAM	M5
M18	SRAM	M7

SUPERMAX FIELD CHANGE NOTICE NO. 81

DATE: 890208

MODULE: CPU 4100

CATEGORY:

Production change.

In the field: To be made without any unnecessary delay.

CORRECTS THE ERROR:

Several latches are implemented in combinatorial PALs. The asynchronous latches are not correctly programmed. The problem is fixed with a new set of PALs with changed programming.

The error is seen with the Supermax Diagnostic Programs as write/read errors during the bus test.

The problem results in unpredictable errors with the Supermax Operating System.

TOOLS NEEDED:

Hand tools.

One PAL C3181

One PAL C3121

One PAL C3131

DESCRIPTION:

1. Change PAL V14 to C3181.
2. Change PAL S11 to C3121.
3. Change PAL S9 to C3131.
4. Update ASSY revision level to E by removing the letter D in ASSY identification field.

CIRCUITS INVOLVED:

Name:	Type:	Position:
V14	PAL C3181	M8
S11	PAL C3121	C6
S9	PAL C331	B5

SUPERMAX FIELD CHANGE NOTICE NO. 73

DATE: 890116

MODULE: 4100 CPU

CATEGORY:

Production change.

In the field:

When errors occur.

When modules are exchanged or installed in systems with 24 positions.

CORRECTS THE ERROR:

The arbitration signals in the Supermax I/O bus are open collector signals, that are driven by all units in the system.

The rise time of these signals is approximately proportional to the number of units in the system.

In a system with 12 positions the rise time is small enough to leave a large margin.

In a system with 24 positions and many units the rise time is larger and a smaller margin remains.

High temperature and low voltage reduces the margin, and errors may occur in large systems. The errors are usually time out errors.

To improve the margin, the rise time is decreased by reducing the pull-up resistors in systems with 24 positions.

The pull-up resistors are reduced by using two sets of pull-up resistors in parallel, one set in each card cage. The pull-up resistors are located on CPU modules and the changes are described in field change notes 71, 72, and 73.

All units in a Supermax system have one or two drivers, that drive the arbitration signals. All drivers in a system must be changed to drive the reduced pull-up resistors.

The necessary changes for all units are described in field change notes 71 - 79.

All units in a system must be updated according to these notes, when the pull-up resistors are reduced as described in field change notes 71, 72, and 73.

A unit, that is updated, may be used in a system where the pull-up resistors are not reduced.

TOOLS NEEDED:

Hand tools.

1 74AS641

DESCRIPTION:

1. Change IC in position U3 from 74ALS641-1 to 74AS641.
2. Update ASSY revision level to D by removing the letter C in ASSY identification field.
3. In systems with 24 positions:

Turn all bits in switch U6 on, on one CPU module, to add an extra set of pull up resistors.

Make sure that two CPU modules have switch U6 turned on, one in each card cage.

SUPERMAX FIELD CHANGE NOTICE NO. 67

DATE: 881123

MODULE: CPU 4100 and CPU 4101

CATEGORY:

Production change.

In the field: To be made at a suitable occasion.

CORRECTS THE ERROR:

There is a possibility that the module changes the unit number during the last clock cycle of an access to the I/O bus. If that happens, it may cause an error in another unit connected to the I/O bus.

TOOLS NEEDED:

Hand tools.

DESCRIPTION:

1. Disconnect L7 pin 23 by making two cuts on the solder side of the of the board. (See next page)
2. Connect L7 pin 2 to the plated through hole, PTH, with a wire on the solder side of the board.
2. Connect L7 pin 23 to U2 pin 15 with a wire on the solder side of the board.
5. Update PCB revision level B to C by removing the letter B.

CPU module 4100/4101 seen from the solder side.

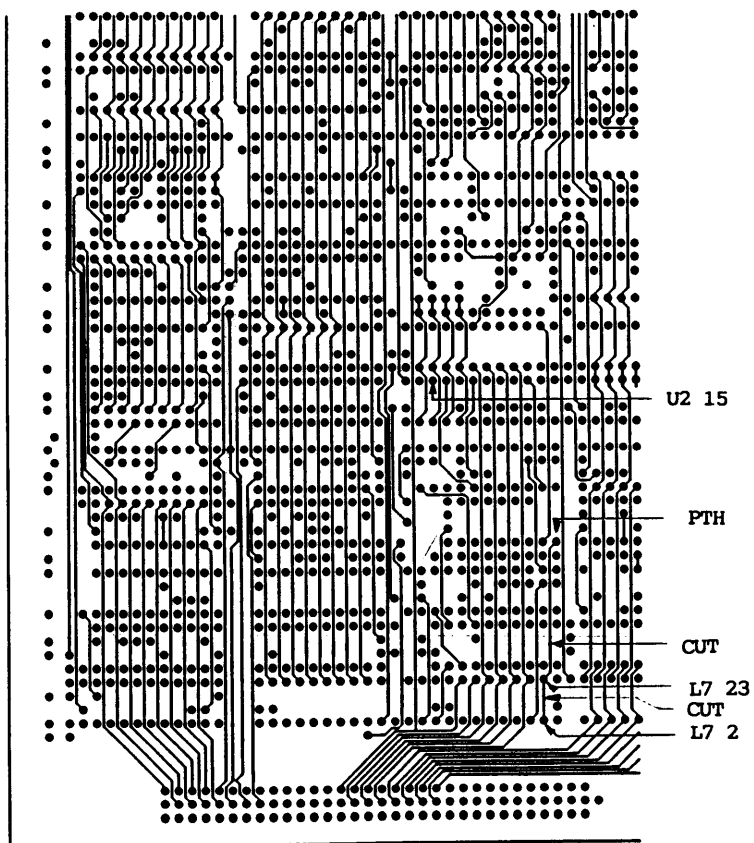

SUPERMAX FIELD CHANGE NOTICE NO. 63

DATE: 881123

MODULE: CPU 4100 and 4101.

CATEGORY:

Production change.

In the field: To be made at a suitable occasion.

CORRECTS THE ERROR:

The CPU does not release the I/O bus immediately after a read modify write cycle.

TOOLS NEEDED:

Hand tools.

DESCRIPTION:

1. Change PAL in position X3 from C3031 to C3032.
 2. Update ASSY revision from B to C by removing the letter B.
-

SUPERMAX FIELD CHANGE NOTICE NO. 62

DATE: 881109

MODULE: CPU 4100 and 4101.

CATEGORY:

Production change.

In the field: To be made when error occurs.

CORRECTS THE ERROR:

Start up problem. The module does not start the self test program after power up or reset. The front panel display shows 88.

TOOLS NEEDED:

Hand tools.

DESCRIPTION:

1. Disconnect B2 pin 13 by cutting the pin close to the board.
2. Connect B2 pin 13 to F1 pin 13 by soldering a wire to the pins on the component side of the board.
3. Update PCB revision from A to B by removing the letter A.

SUPERMAX FIELD CHANGE NOTICE NO. 61

DATE: 881108

MODULE: CPU 4100.

CATEGORY:

Production change.

In the field: To be made when error occurs.

CORRECTS THE ERROR:

Problems with service port when a real time clock module is installed.

TOOLS NEEDED:

Hand tools.

Three 4K7 resistors.

DESCRIPTION:

1. Change resistors PR1,PR2,PR3 from 10K to 4K7.
 2. Update ASSY revision level from A to B by removing the letter A.
-

Supermax Field Change Notice no. 122

Module:	CPU 4501, ISS 1 and ISS 2. R3000 CPU - FCN no 4.
Date:	93-01-04

Category:

- Production change.
- In the field: Before the Supermax platform, The Optimized RISC Platform, is installed on Supermax SM4, SM6, SM12 and SM24.

Corrects the error:

- Missing support of fast boot.

This firmware will support fast boot. Fast boot is only supported in the new cabinets SM4, SM6, SM12 and SM24. The main memory is not tested, but it is initialized. This happens during the following condition:

- Key switch in **SYSTEM**
- **SHUTDOWN** push button activated and **START** push button activated. **SHUTDOWN** push button must be activated until the display shows P0.

Needed tools:

Hand tools.

Supermax FCN kit 122, stock number 95101220, consisting of:

- One EPROM labeled "R3BOOT-0 Vers 2.0 92.11.01"
- One EPROM labeled "R3BOOT-1 Vers 2.0 92.11.01"
- One EPROM labeled "R3BOOT-2 Vers 2.0 92.11.01"
- One EPROM labeled "R3BOOT-3 Vers 2.0 92.11.01"

Description:

- Replace EPROM device F5 with EPROM labeled "R3BOOT-0"
- Replace EPROM device F4 with EPROM labeled "R3BOOT-1"
- Replace EPROM device F3 with EPROM labeled "R3BOOT-2"
- Replace EPROM device F2 with EPROM labeled "R3BOOT-3"

Circuits involved:

Name	Type	Position
F2-F5	EPROM 27512	M11

Supermax Field Change Notice no. 107

Module: CPU 4501, ISS 1 and 2.

Date: 91.01.30

Category:

- Production change.
- In the field: To be made without any unnecessary delay.

Corrects the error:

- The error results in system crash, display code 87 with the Supermax Operating System.

Needed tools:

Hand tools.

Description:

1. Connect G8 pin 11 to G8 pin 10 with insulated wire on the solder side of the PCB.
2. Disconnect G8 pin 11 from the PCB by cutting the pin close to the device.
3. Update PCB revision field:
 - 4501 ISS 1: Update to revision D by removing the letter C in the PCB identification field.
 - 4501 ISS 2: Update to revision C by removing the letter B in the PCB identification field.

Circuits involved:

Name	Type	Position
G8	74LS390	M6

Supermax Field Change Notice no. 102

Module: CPU 4501, ISS 1 and 2.

Date: 91.06.04

Category:

- Production change.
- In the field: To be made without any unnecessary delay.

Corrects the error:

- The error is seen, when using the Supermax Diagnostics bus test program as a mismatch between read and write data.
- The error results in unpredictable errors, system crash or system hang-up with the Supermax Operating System.

Needed tools:

Hand tools.

Supermax FCN kit 102, stock number 95101020, consisting of:

1. One PAL labeled "C4021"
2. One PAL labeled "C4151"

Description:

1. Connect H15 pin 12 to H1 pin 16 with insulated wire on the component side of the PCB.
2. Replace PAL C4020 with C4021.
3. Replace PAL C4150 with C4151.
4. Update PCB revision field:
 - 4501 ISS 1: Update to revision C by removing the letter B in the PCB identification field.
 - 4501 ISS 2: Update to revision B by removing the letter A in the PCB identification field.

Circuits involved:

Name	Type	Position
H1	C4020	L4
H15	74LS14	J5
L4	C4150	L8

Supermax Field Change Notice no. 97

Module:	CPU 4501, ISS 1.
Date:	91.01.09

Category:

- Production change.
- In the field: Before Supermax operating system 530.5N (or later version) is installed.

Corrects the error:

- The 530.5N operating system use broadcast write cycles. The broadcast cycles are not working correctly due to an wired-or glitch.
- The error results in unpredictable errors, system crash or system hang-up with the Supermax Operating System.

Needed tools:

Hand tools.

Supermax FCN kit 097, stock number 95100970, consisting of:

1. One resistor, 180 ohm.

Description:

1. Cut the PCB wire on the solder side of the PCB. See the attached page. The wire connects RN7 pin 8 to H14 pin 8.
2. Connect RN7 pin 8 to H14 pin 8 with a 180 ohm resistor on the solder side of the PCB.
3. Update PCB revision field: Update to revision B by removing the letter A in the PCB identification field.

Circuits involved:

Name	Type	Position
RN7	SIL	H6
H14	SWITCH	H5

CPU 4501, ISS 1. Solder side.

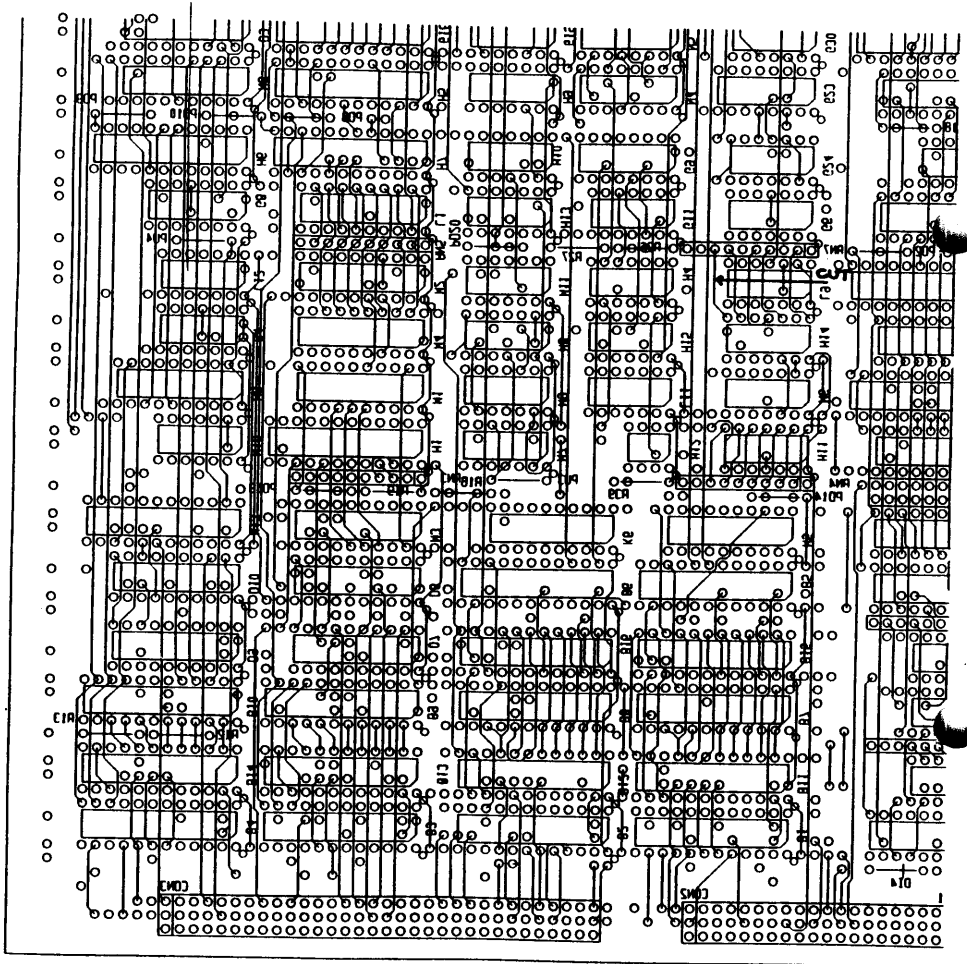

SUPERMAX FIELD CHANGE NOTICE NO. 75

DATE: 890116

MODULE: 0400/0401/0402 DIOC

CATEGORY:

Production change.

In the field:

When errors occur.

When modules are exchanged or installed in systems with 24 positions.

CORRECTS THE ERROR:

The arbitration signals in the Supermax I/O bus are open collector signals, that are driven by all units in the system.

The rise time of these signals is approximately proportional to the number of units in the system.

In a system with 12 positions the rise time is small enough to leave a large margin.

In a system with 24 positions and many units the rise time is larger and a smaller margin remains.

High temperature and low voltage reduces the margin, and errors may occur in large systems. The errors are usually time out errors.

To improve the margin, the rise time is decreased by reducing the pull-up resistors in systems with 24 positions.

The pull-up resistors are reduced by using two sets of pull-up resistors in parallel, one set in each card cage. The pull-up resistors are located on CPU modules and the changes are described in field change notes 71, 72, and 73.

All units in a Supermax system have one or two drivers, that drive the arbitration signals. All drivers in a system must be changed to drive the reduced pull-up resistors.

The necessary changes for all units are described in field change notes 71 - 79.

All units in a system must be updated according to these notes, when the pull-up resistors are reduced as described in field change notes 71, 72, and 73.

A unit, that is updated, may be used in a system where the pull-up resistors are not reduced.

TOOLS NEEDED:

Hand tools.

2 74AS641

DESCRIPTION:

1. Change IC in position N2 from 74ALS641-1 to 74AS641.
2. Change IC in position N4 from 74ALS641-1 to 74AS641.
3. If DIOC 0400 or DIOC 0401 update revision level to H by removing the letter G from the revision level field.

If DIOC 0402 update revision level to G by removing the letter F in the revision level field.

SUPERMAX FIELD CHANGE NOTICE NO. 28

DATE: 860120

MODULE: DIOC MODULE 0400, 0401 and 0402.

CATEGORY:

Production change.

In the field: To be made without any unnecessary delay.

CORRECTS THE ERROR:

Unix environment:

Seen from the user the system is down. Typically the system dies or crashes with a display error code 00.

Supermax diagnostic programs:

The DIOC displays usually the error message ESR 0000 0000.

NEEDED TOOLS:

Hand tools. PAL D32 and D42. Resistor 5.6 Kohm.

DESCRIPTION:

1. Check with ohm-meter the connection between L7 pin 09 and T2 pin 16. (PAL D10)
2. Disconnect L7 pin 09 by cutting wire on the solder side near the pin.
3. Check no-connection between L7 pin 09 and T2 pin 16.
4. Connect L7 pin 09 to P4 pin 08 with insulated wire on the component side.
5. Change PAL D40 to D42, package 02. Insert D42 in the socket with pin 04 out of the socket.

6. Connect I5 pin 16 to O2 pin 04 with insulated wire on the component side.
7. Cut M4 pin 10 near the PCB.
8. Connect M4 pin 10 to M3 pin 05 with insulated wire on the component side.
9. Change resistor RS1 from a 2.2 Kohm to a 5.6 Kohm resistor.

If FCN 21 not is made then:

10. Check with ohm-meter the connection between PAL D30, package P2 pin 07 and P3 pin 05.
11. Disconnect P2 pin 07 by cutting wire on the solder side near the pin.
12. Check no-connection between P2 pin 07 and P3 pin 05.
13. Connect P2 pin 07 to T2 pin 16 with insulated wire on the solder side.
14. Change PAL package P2 from D30 to D32.

If FCN 21 is made then:

15. Remove wire between P2 pin 07 and P1 pin 29.
16. Connect P2 pin 07 to T2 pin 16 with insulated wire on the solder side.
17. Change PAL package P2 from D31 to D32.
18. Change revision level:

For DIOC 0400 and DIOC 0401 update PCB revision level to G by removing the letter F from the solder side.

For DIOC 0402 update PCB revision level to F by removing the letter E from the solder side.

CIRCUITS INVOLVED:

Name	Type	Position
L7	74LS14	A 5,7.
T2	PAL D10	A 9,8.
P4	74S04	B 4,9. Between H1 and M3.
O2	PAL D40	B 1,3.
I5	74ALS574	B 2,4.
M3	74LS11	B 4,10.
M4	74LS74	B 5,9.
P2	PAL D30	B 3,7.
P3	74ALS74	B 5,7.
P1	8085	B 1,8.
RS1	2K2 resistor	B 7,3. Between S3 and R2. Near pin 01 and 16 on K4, 74LS393.

SUPERMAX FIELD CHANGE NOTICE NO. 21

DATE: 850814

MODULE: DIOC MODULE 0400, 0401 and 0402.

CATEGORY:

PRODUCTION CHANGE.

IN THE FIELD:
TO BE MADE AT A SUITABLE OCCASION.

CORRECTS THE ERROR:

Bug in the arbitration between internal and external memory cycles. The bug is only visible, when the module runs the SUPERMAX diagnostic program "bustest".

NEEDED TOOLS: HAND TOOLS. PAL D31. Insulated wire.

DESCRIPTION:

Package P1 is LSI 8085, Position B 1,9

Package P2 is PAL D30, Position B 3,7

Disconnect P2 pin 07 by cutting the wire on the solder side close to the pin.

Connect P2-07 to P1-29 with insulated wire on the solder side of the board.

PAL package P2 is changed from D30 to D31.

For DIOC 0400 and DIOC 0401 update PCB revision level from E to F by removing the letter E from the solder side.

For DIOC 0402 update PCB revision level from D to E by removing the letter D from the solder side.

SUPERMAX FIELD CHANGE NOTICE NO. 16

DATE: 841203

MODULE: 400, 401, AND 402 DIOC MODULE

CATEGORY:

PRODUCTION CHANGE.

IN THE FIELD: TO BE MADE AT A SUITABLE OCCASION.

CORRECTS THE ERROR:

CHANGES THE FREQUENCY OF THE TIMER INTERRUPT.

DESCRIPTION:

Remove jumper between SK3-1 and SK4-1.

Place jumper between SK3-5 and SK4-5.

SK3 AND SK4 are placed in position C 3,2.

SUPERMAX FIELD CHANGE NOTICE NO. 15

DATE: 841129

MODULE: 0400D, 0401D, and 0402C DIOC MODULE

CATEGORY:

PRODUCTION CHANGE.

IN THE FIELD: TO BE MADE WITHOUT ANY UNNECESSARY DELAY.

CORRECTS THE ERROR:

Wrong orientation of electrolytic capacitor CU1.

The capacitor CU1 controls read and write delay after head load in the floppy disk interface. The fault may cause read or write errors after head load.

NEEDED TOOLS:

Hand tools. Electrolytic capacitor 6.8 uF, 25v

DESCRIPTION:

CU1 is placed close to the service port connector. Unsolder old CU1 and replace with new CU1. New CU1 must have +pin connected to U7-6 and -pin connected to U7-7, that is +pin closest to the service port.

For DIOC 0400 and DIOC 0401 update revision level from D to E by removing the letter D from the solder side.

For DIOC 0402 update revision level from C to D by removing the letter C from the solder side.

SUPERMAX FIELD CHANGE NOTICE NO. 10

DATE: 840924 KAN

MODULE: 0400, 0401, and 0402 DIOC MODULE for 8" floppy disk drives. SPC-1 7045X FOR 8" floppy disk drives.

CATEGORY:

PRODUCTION CHANGE.

IN THE FIELD: TO BE MADE WITHOUT ANY UNNECESSARY DELAY.

CORRECTS THE ERROR:

Reduced write current must be used on the inner tracks on 8" floppy disks.

NEEDED TOOLS:

Hand tools. Insulated wire.

DESCRIPTION:

Connect pin 2 to pin 8 in the connector to the floppy disk on the solder side of the board. Pin 2 and pin 8 in the floppy disk interface are now driven by the TG43 signal from the floppy disk controller. Make sure that the disk drive is strapped to use reduced write current when pin 2 or pin 8 is driven low. Refer to the manual for the disk drive in question.

For DIOC 0400 and DIOC 0401 update revision level from C to D by removing the letter C from the solder side.

For DIOC 0402 update revision level from B to C by removing the letter B from the solder side.

Disk drives:

BASF 6104: NO CHANGE NECESSARY.

QUME DATA TRACK 8: STRAPS LI AND LC MUST BE IN PALCE.

CDC 9406-4: SWITCH LC MUST BE ON: S2-12 CONNECTED TO S2-05.
SWITCH MW MUST BE ON: S2-03 CONNECTED TO S2-14.

NEC 1165-F: NO STRAPS INVOLVED.

SUPERMAX FIELD CHANGE NOTICE NO. 6

DATE: 840203.

MODULE: 0400, 0401 AND 0402 DIOC MODULE

CATEGORY:

TO BE MADE AT A SUITABLE OCCASION OR
TO BE MADE WHEN ERROR OCCURS.

CORRECTS THE ERROR:

ERROR MAY OCCUR DURING DISKCOPY FROM A STREAMING TAPE TO A
WINCHESTER DISK.

AFTER ERROR: NO ACCESS POSSIBLE TO THE DISKS ON ONE DIOC.

NEEDED TOOLS:

HAND TOOLS AND THIN WIRE WITH TEFLON INSULATION.

DESCRIPTION:

1. COMPONENT R1, 74LS423.
CUT PIN 3 ON THE COMPONENTSIDE OF THE PCB. CUT NEAR THE PCB.
2. REMOVE THE PIN AND CLEAN THE HOLE.
3. PUT THE WIRE THROUGH THE PIN 3 HOLE, FROM THE SOLDER SIDE TO THE COMPONENTSIDE.
4. CONNECT THE WIRE TO R1 PIN 3 ON THE COMPONENTSIDE.
5. CONNECT THE WIRE TO L1 PIN 14 ON THE SOLDERSIDE.
6. NOW R1 PIN 3 IS CONNECTED TO L1 PIN 14.
7. IF DIOC MODULE 0400 THEN UPDATE REVISION LEVEL FROM 0400 B TO 0400 C BY REMOVING THE LETTER B ON THE SOLDER SIDE

IF DIOC MODULE 0401 THEN UPDATE REVISION LEVEL FROM 0401 B TO
0401 C BY REMOVING THE LETTER B ON THE SOLDER SIDE

IF DIOC MODULE 0402 THEN UPDATE REVISION LEVEL FROM 0402 A TO
0402 B BY REMOVING THE LETTER A ON THE SOLDER SIDE

CIRCUITS INVOLVED:

NAME	TYPE	POSITION
R1	74LS423	B 1,10
L1	PAL-D80	A 6,9

SUPERMAX FIELD CHANGE NOTICE NO. 4DATE: 831012.MODULE: 0400 AND 0401 DIOC MODULECATEGORY:

TO BE MADE WITHOUT ANY UNNECESSARY DELAY.

CORRECTS THE ERROR:

NO ACCESS POSSIBLE TO THE DISKS ON ONE DIOC.

PROPABILITY OF OCCURRENCE PROPORTIONAL WITH THE DISK LOAD.

NEEDED TOOLS:

HAND TOOLS.

DESCRIPTION:

1. REPLACE DMA CONTROLLER AM9517A-4 WITH AM9517A-5.
2. UPDATE REVISION LEVEL FROM 040X A TO 040X B BY REMOVING THE LETTER A ON THE SOLDER SIDE.

CIRCUITS INVOLVED:

NAME	TYPE	POSITION
Q1	AM9517A	A 9,5

SUPERMAX FIELD CHANGE NOTICE NO. 85DATE: 890627MODULE: DIOC 1100 and 1101.CATEGORY:

Production change.

In the field: To be made without any unnecessary delay if any Supermax module in the machine is updated with Field Change Note 71-79.

CORRECTS THE ERROR:

System crash 00 due to a bus error on the common I/O bus.

NEEDED TOOLS:

Hand tools.

PAL D2104.

DESCRIPTION:

1. Change PAL L2 to D2104.

2. Update ASSY revision level field on:

DIOC 1100 to F by removing the letter E in ASSY identification field.

DIOC 1101 to E by removing the letter D in ASSY identification field.

CIRCUITS INVOLVED:

Name:	Type:	Position:
L2	PAL	A 4,4

SUPERMAX FIELD CHANGE NOTICE NO. 78

DATE: 890116

MODULE: 1100/1101 DIOC

CATEGORY:

Production change.

In the field:

When errors occur.

When modules are exchanged or installed in systems with 24 positions.

CORRECTS THE ERROR:

The arbitration signals in the Supermax I/O bus are open collector signals, that are driven by all units in the system.

The rise time of these signals is approximately proportional to the number of units in the system.

In a system with 12 positions the rise time is small enough to leave a large margin.

In a system with 24 positions and many units the rise time is larger and a smaller margin remains.

High temperature and low voltage reduces the margin, and errors may occur in large systems. The errors are usually time out errors.

To improve the margin, the rise time is decreased by reducing the pull-up resistors in systems with 24 positions.

The pull-up resistors are reduced by using two sets of pull-up resistors in parallel, one set in each card cage. The pull-up resistors are located on CPU modules and the changes are described in field change notes 71, 72, and 73.

All units in a Supermax system have one or two drivers, that drive the arbitration signals. All drivers in a system must be changed to drive the reduced pull-up resistors.

The necessary changes for all units are described in field change notes 71 - 79.

All units in a system must be updated according to these notes, when the pull-up resistors are reduced as described in field change notes 71, 72, and 73.

A unit, that is updated, may be used in a system where the pull-up resistors are not reduced.

TOOLS NEEDED:

Hand tools.

2 74AS641

DESCRIPTION:

1. Change IC in position N4 from 74ALS641-1 to 74AS641.
2. Change IC in position N5 from 74ALS641-1 to 74AS641.
3. If DIOC 1100, update ASSY revision level to E by removing the letter D in ASSY identification field.

If DIOC 1101, update ASSY revision level to D by removing the letter C in ASSY identification field.

SUPERMAX FIELD CHANGE NOTICE NO. 59

DATE: 881012

MODULE: DIOC 1100 and 1101

CATEGORY:

Production change.
To be made at a suitable occasion.

CORRECTS THE ERROR:

The voltage level is too low on the interrupt bus during interrupt acknowledge cycles. The interrupt bus is pulled up during acknowledge cycles with resistor network SF1.

The error is seen with the diagnostic programs running interrupt test.

TOOLS NEEDED:

Hand tools.
Single inline resistor network, 1 Kohm. Ex. 10x-1-102.

DESCRIPTION:

1. Exchange resistor network SF1 to a 1 Kohm part.
2. Update ASSY revision level on DIOC 1101 from B to C by removing the letter B in the ASSY revision field.
3. Update ASSY revision level on DIOC 1100 from C to D by removing the letter C in the ASSY revision field.

CIRCUIT INVOLVED:

SF1 is located between package B6 and B9.

SUPERMAX FIELD CHANGE NOTICE NO. 56

DATE: 880622

MODULE: DIOC 1101.

CATEGORY:

Production change.

In the Field: To be made when error occurs.

CORRECTS THE ERROR:

Not possible to adjust the floppy disk controller.

The free running VCO freq. is adjusted with a variable capacitor. It is necessary to mount a capacitor in serie with the variable capacitor because of new PCB and component specifications.

NEEDED TOOLS:

1. Hand tools.
2. One ceramic capacitor, 47 pF.

DESCRIPTION:

1. Remove the shortcircuit wire in position KC2.
2. Mount a 47pF ceramic capacitor in position KC2.
3. Update ASSY revision level from A to B by removing the letter A.

CIRCUIT INVOLVED:

KC2 is located between the floppy disk controller K3 (SAB 2797B) and the switch KS1.

For floppy disk controller adjustment see Supermax technical note number 3.

SUPERMAX FIELD CHANGE NOTICE NO. 51

DATE: 871029

MODULE: DIOC 1100 and 1101.

CATEGORY:

Production change.

In the field: To be made at a suitable occasion
or
to be made when error occurs.

CORRECTS THE ERROR:

Supermax diagnostic programs: BTU read/write error during bustest.

The problem is a marginal timing. The worst case situation is when the board is cold.

NEEDED TOOLS:

Hand tools.
PAL D2P71.
Insulated wire.
TTL component 74S00.

DESCRIPTION:

1. Package G4: Cut pin 4 near the PCB.
2. Connect package G4 pin 4 to package P1 pin 4 with insulated wire on the component side of the PCB.
3. Remove package J5, PAL D2P70.
4. Insert PAL D2P71 in position J5 with pin 11 out of the socket.
5. Connect PAL D2P71 pin 11 to G6 pin 1 with insulated wire on the component side of the PCB.

6. Change revision level on DIOC 1100 to F by removing the letter G in the PCB identification on the component side of the board.

Change revision level on DIOC 1101 to B by removing the letter A in the PCB identification on the component side of the board.

CIRCUITS INVOLVED:

Name	Type	Position
G4	74S00	Located near 8085 CPU.
G6	74S04	Located near the DRAM array.
J5	PAL D2P70	
P1	PAL D2P90	

SUPERMAX FIELD CHANGE NOTICE NO. 44

DATE: 870501

MODULE: DIOC 1100

CATEGORY:

Production change.

In the field: To be made without any unnecessary delay.

CORRECTS THE ERROR:

The supermax diagnostic program revision 4.0 detects a parity error in the program memory bank during a bustest.

Seen from the user the system is down.

The problem is a marginal timing when an internal interrupt cycle is executed simultaneously with an access from the supermax io bus.

NEEDED TOOLS:

PAL d2p103.

DESCRIPTION:

1. Change PAL package L2 from d2p102 to d2p103.
2. Change revision level to C by removing the letter B in the ASSY identification on the component side of the board.

CIRCUITS INVOLVED:

Name	Type	Position
L2	PAL	A 4,4

SUPERMAX FIELD CHANGE NOTICE NO. 37

DATE: 860203

MODULE: DIOC MODULE 1100.

CATEGORY:

Production change.

In the field: To be made when error occurs.

CORRECTS THE ERROR:

Read problems on floppy disks.

The WD2795 floppy disk controller has an on-chip data separator. The data separator includes a voltage controlled oscillator. This oscillator has a nonlinear characteristic and is temperature sensitive. The SIEMENS 2797B is a redesigned controller with an improved VCO and extended technical characteristics of the PLL.

NEEDED TOOLS:

Hand tools.
Oscilloscope.
Frequency counter, optional.

SIEMENS 2797B, floppy disk controller.
74LS646, data buffer.
74LS645, data buffer.
2 TEKELEC/JOHANSON 9694, trim capacitors.

DESCRIPTION:

1. Change component K4 from a 74LS648 part to a 74LS646 part.
2. Change component K5 from a 74LS640 part to a 74LS645 part.

3. Change component K3 WD2795 to a SIEMENS 2797B floppy disk controller.
4. Change component KC5 to a TEKELEC/JOHANSON 9694 trim capacitor.
5. Change component KC3 to a TEKELEC/JOHANSON 9694 trim capacitor.
6. Make the adjustments as described in Supermax technical note number 3, revision 1.
7. Change revision level to B by removing the letter A in the ASSY identification on the component side of the board.

CIRCUITS INVOLVED:

Name	Type	Position
K3	WD2795	B 10,5
K4	74LS648	B 7,4
K5	74LS640	B 8,4
KC5	trim.cap.	B 12,5
KC3	trim cap.	B 11,2

SUPERMAX FIELD CHANGE NOTICE NO. 34, revision 1.DATE: 880406MODULE: DIOC MODULE 1100.CATEGORY:

Production change.

In the field: To be made when installing a peripheral unit on the SCSI interface.

CORRECTS THE ERROR:

Hang up on SCSI interface during command and status handshake.

NEEDED TOOLS:

Hand tools.

DESCRIPTION:

1. Connect S14 pin 8 to S4 pin 2 with insulated wire on the component side.
2. Change revision level to F by removing the letter E in the PCB identification on the component side of the board.

CIRCUITS INVOLVED:

Name	Type	Position
S14	74S74	C 1,10
S4	74ALS580	B 12,9

SUPERMAX FIELD CHANGE NOTICE NO. 31

DATE: 860120

MODULE: DIOC MODULE 1100

CATEGORY:

Production change.

In the field: To be made without any unnecessary delay.

CORRECTS THE ERROR:

Unix environment:

Seen from the user the system is down. Typically the system dies or crashes with a display error code 00.

Supermax diagnostic programs:

The DIOC displays usually the error message ESR 0100 0000.

NEEDED TOOLS:

Hand tools.

PAL D2P161.

3 components of type 74AS574.

DESCRIPTION:

1. Check with ohm-meter the connection between PAL D2P160, package L3 pin 8 and the 1 kohm pull up resistor near the pin.
2. Disconnect L3 pin 08 by cutting wire between pin and the pull up resistor. on the solder side.
3. Check no-connection between L3 pin 08 and the pull up resistor.
4. Connect L3 pin 08 to PAL D2P102, package L2 pin 04 with insulated wire on the solder side.

5. Change PAL D2P160 to D2P161.
6. Cut Q9 pin 13 near the PCB.
7. Connect Q9 pin 13 to Q4 pin 12 with insulated wire on the component side.
8. Change L1 from 74ALS574 to 74AS574.
9. Change O1 from 74ALS574 to 74AS574.
10. Change H12 from 74ALS574 to 74AS574.
11. Change revision level to E by removing the letter D in the PCB identification on the component side of the board.

CIRCUITS INVOLVED:

Name	Type	Position
L3	PAL D2P160	A 7,7.
L2	PAL D2P102	A 4,4.
Q9	74LS74	B 2,5.
Q4	74S08	B 1,5.
L1	74ALS574	A 4,6.
O1	74ALS574	A 5,8.
H12	74ALS574	B 8,6.

SUPERMAX FIELD CHANGE NOTICE NO. 27

DATE: 851129

MODULE: DIOC MODULE 1100

CATEGORY:

PRODUCTION CHANGE.

IN THE FIELD: TO BE MADE WITHOUT ANY UNNECESSARY DELAY.

CORRECTS THE ERROR:

System hang up because of a memory parity error or last byte in a sector garbaged after a winchester disk read command.

NEEDED TOOLS:

Hand tools. PAL D2P61.

DESCRIPTION:

1. Check with ohm-meter the connection between S13 pin 02 and D2 pin 09.
2. Disconnect S13 pin 02 by cutting wire on the solder side. See page 4.
3. Check no-connection between S13 pin 02 and D2 pin 09.
4. Connect S13 pin 02 to S3 pin 15 with insulated wire on the solder side.
5. Check with ohm-meter the connection between S13 pin 05 and S10 pin 01.
6. Disconnect S13 pin 05 by cutting wire on the solder side. See page 4.
7. Check no-connection between S13 pin 05 and S10 pin 01.

8. Connect S13 pin 05 to S3 pin 06 with insulated wire on the solder side.
9. Check with ohm-meter the connection between S13 pin 07 and S18 pin 05.
10. Disconnect S13 pin 07 by cutting wire on the solder side. See page 4.
11. Check no-connection between S13 pin 07 and S18 pin 05.
12. Connect S13 pin 07 to S10 pin 08 with insulated wire on the solder side.
13. Check with ohm-meter the connection between E20 pin 02 and G6 pin 05.
14. Disconnect E20 pin 02 by cutting wire on the solder side. See page 4.
15. Check no-connection between E20 pin 02 and G6 pin 05.
16. Connect E20 pin 02 to G6 pin 08 with insulated wire on the component side.
17. Change PAL package S13 from D2P60 to D2P61.
18. Change revision level from C to D by removing the letter C in the PCB identification on the component side of the board.

CIRCUITS INVOLVED:

Name	Type	Position
S13	PAL D2P60	B 13,5.
D2	2681	B 13,2.
S3	74LS273	B 11,7.
S10	74S74	B 11,5.
S18	74S74	B 12,7.
E20	74S00	A 11,8.
G6	74S04	B 1,3.

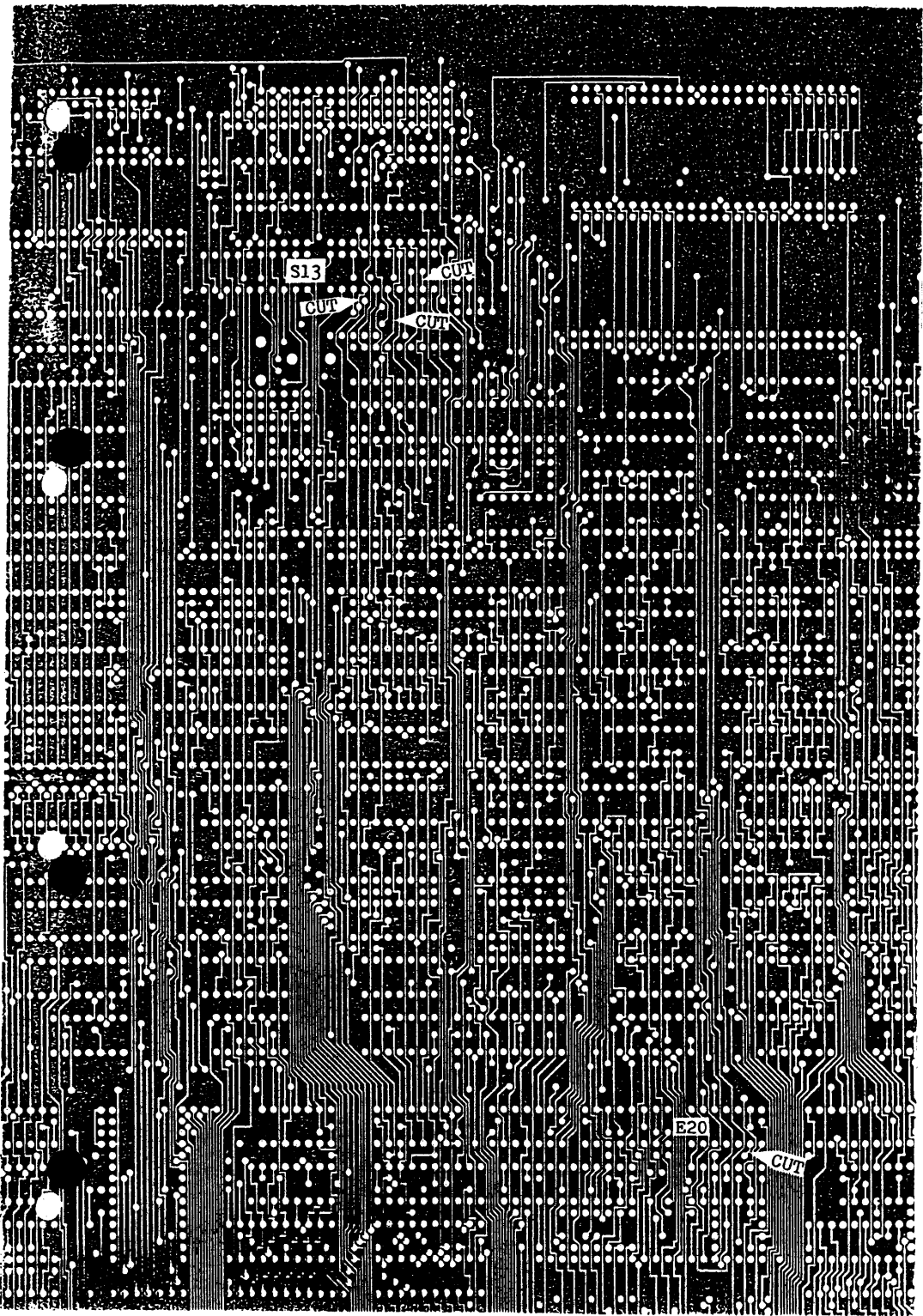

S13

CUT

CUT

CUT

E20

CUT

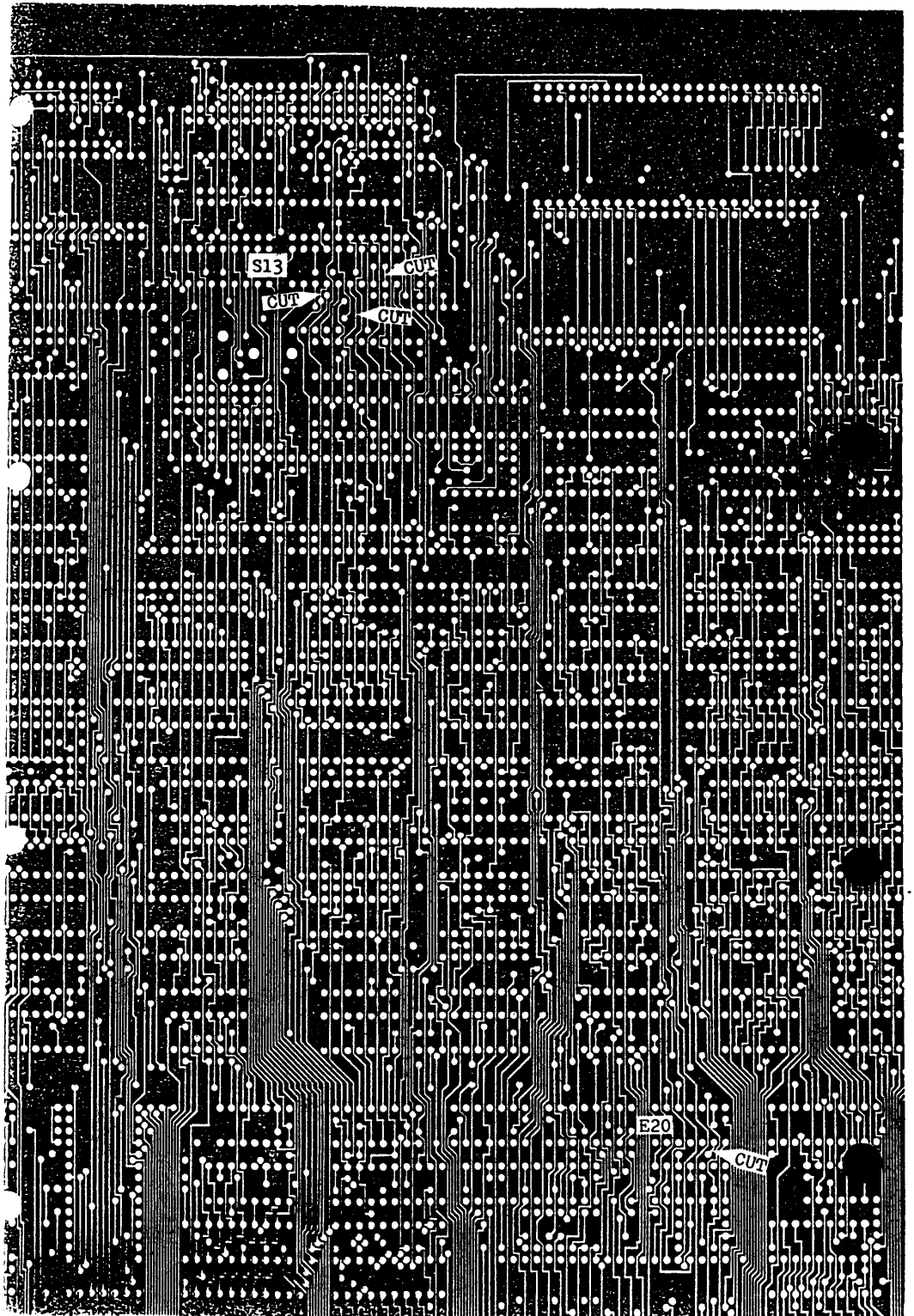

S13

CUT

CUT

CUT

E20

CUT

SUPERMAX FIELD CHANGE NOTICE NO. 25

DATE: 850820

MODULE: DIOC MODULE 1100

CATEGORY:

PRODUCTION CHANGE.

IN THE FIELD:

To be made at a suitable occasion.

CORRECTS THE ERROR:

This is an extension to supermax field change notice no. 23. As an assistance three different copies of the silkscreen are enclosed.

NEEDED TOOLS:

Hand tools. Resistor, 1k ohm.

DESCRIPTION:

Package H10 is 74S74, position B 12,7.

Connect 1k ohm resistor between H10 pin 14 and H10 pin 10 on solder side of the board.

Package G5 is 74S00, position A 11,1.

Cut G5 pin 10 near the PCB. Connect G5 pin 10 to G5 pin 09 on component side of the board.

Change revision level from B to C by removing the letter B in the PCB identification on the component side of the board.

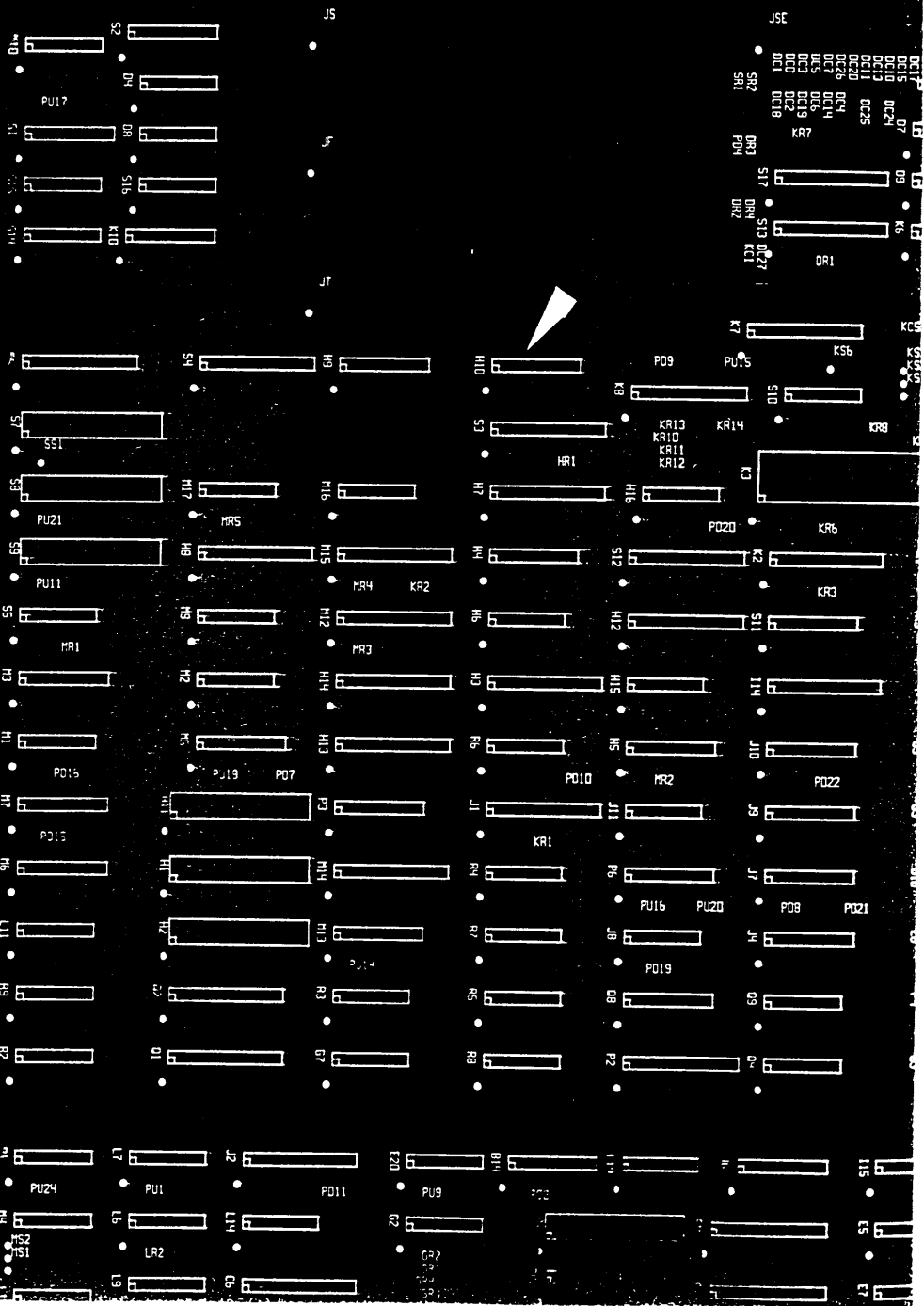

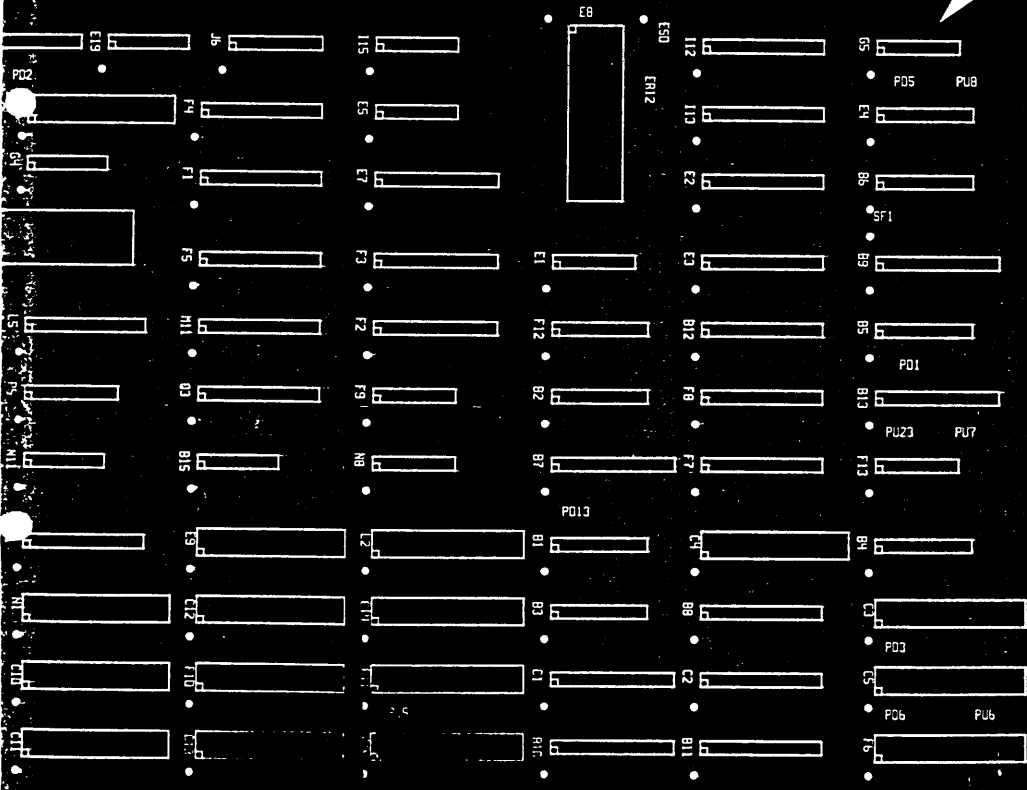
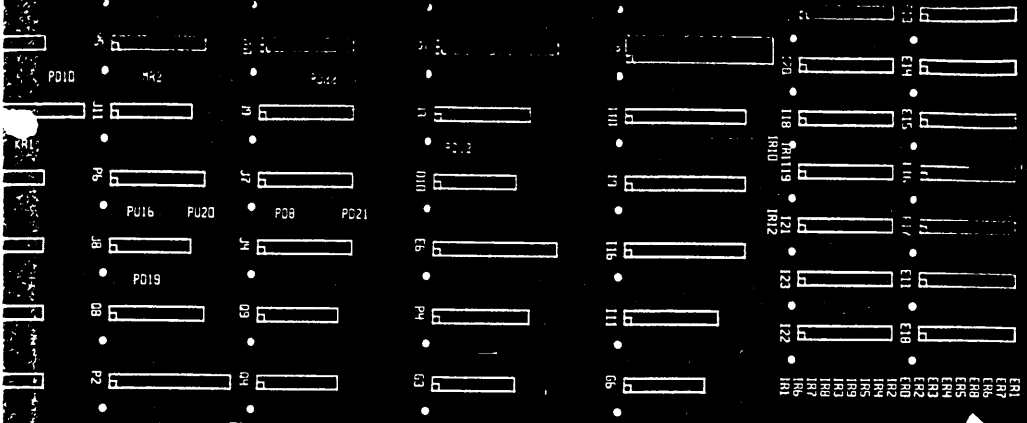

45555

55555

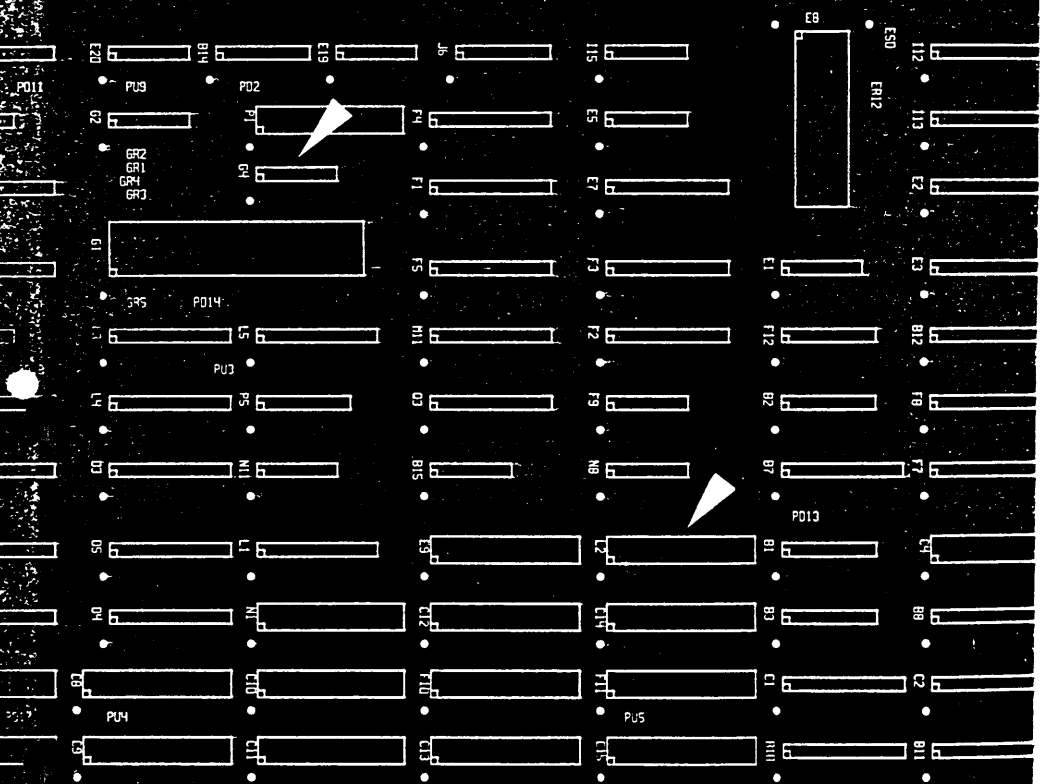
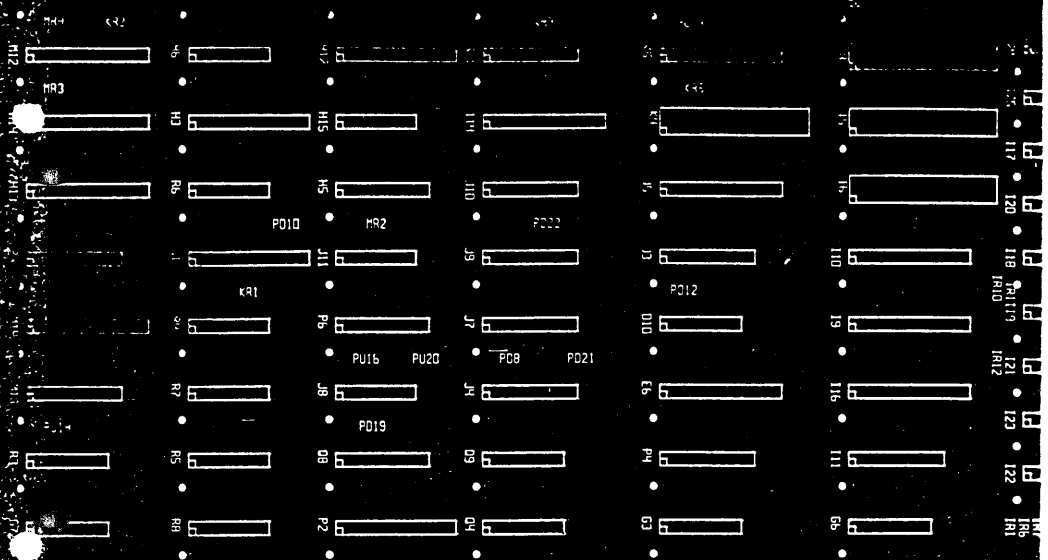

J1C
J1B
J1A

J1C
J1B
J1A

SUPERMAX FIELD CHANGE NOTICE NO. 23DATE: 850814MODULE: DIOC MODULE 1100CATEGORY:

PRODUCTION CHANGE.

IN THE FIELD:
TO BE MADE AT A SUITABLE OCCASION.

CORRECTS THE ERROR:

Bug in the arbitration between internal and external memory cycles. The bug is only visible, when the module runs the SUPERMAX diagnostic program "bustest".

NEEDED TOOLS:

HAND TOOLS. PAL D2P102. Insulated wire.

DESCRIPTION:

Package G4 is 74S00, Position A 9,6
Package L2 is PAL D2P100, Position A 4,4

Connect G4-05 to L2-14 with insulated wire on the solder side of the board.

PAL package L2 is changed from D2P100 or D2P101 to D2P102.

Change revision level from A to B by removing the letter A in the PCB identification on the component side of the board.

Supermax Field Change Notice no. 142

Module:	DIOC4000-4Mb, DIOC4000-8Mb and DIOC4000-32Mb
Date:	94.06.24

Category:

- Production change.
- In the field, when booting from a Seagate 12550 (2047Mb).
- In the field, when booting from a disk, after a power-up, fails.

Corrects the error:

- When booting from a disk, that has a long "power-up / motor start-up time", the DIOC4000 firmware will not boot from the disk. This is because the disk reports *Not ready* status, when the DIOC4000 is reading.
- This error has only been seen on a DIOC4000-4Mb module with a Seagate 12550 disk.
- The new boot firmware will issue a SCSI start unit command (starting the spindle motor) to the disk and wait until the disk is ready.

Needed tools:

Hand tools.

Supermax FCN kit 142, stock number 95101420, consisting of:

1. One EPROM labeled "D3Q010 Vers 4.1 94.06.09"

Description:

- Replace EPROM device Q1 with EPROM labeled "D3Q010 Vers 4.1 94.06.09".

Circuits involved:

Name	Type	Position
Q1	EPROM 27512	L8

Supermax Field Change Notice no. 127

Module:	DIOC4000, PCB 4000 ISS 1 (FCN no 17).
Module:	DIOC4000, PCB 4000 ISS 2 (FCN no 8).
Date:	93-02-03

Category:

- Production change.
- In the field, if error occurs.

Corrects the error:

- Timeout problems on the DIOC. The time before timeout is increased from 100 μ s to 1 ms. The error is seen as various system crash error codes.

Needed tools:

Hand tools.

Small piece of insulated wire.

Description:

1. Cut the connection between J8 pin 5 and J11 pin 9 on the component side of the PCB. (See the drawing on page 2, regarding the location of that connection.)
2. Connect J9 pin 6 and J11 pin 9 using insulated wire on the component side of the PCB.
3. Update the PCB revision field:
 - DIOC4000 ISS 1: Update to revision K by removing the letter J in the PCB revision field label.
 - DIOC4000 ISS 2: Update to revision G by removing the letter F in the PCB revision field.

Circuits involved:

Name	Type	Position
J9	74LS390	L15
J11	74AS1004	L13

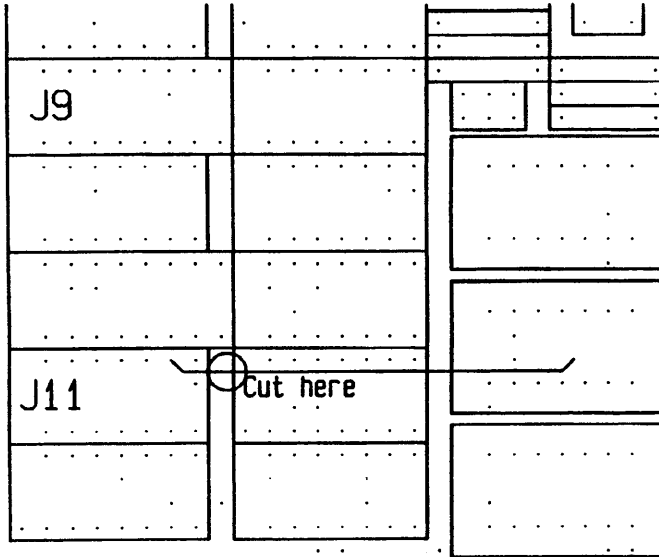

Board layout details DIOC4000.

Supermax Field Change Notice no. 114

Module:	DIOC 4000 ISS 1 (FCN no 16) and ISS 2 (FCN no 7).
Date:	92-10-21

Category:

- Production change.
- In the field, when installing a R4000MCU module in a system.

Corrects the error:

- The communication between the DIOC module and the R4000MCU module does not function correctly.

Needed tools:

Hand tools.

Supermax FCN kit 114, stock number 95101140, consisting of:

1. 20cm insulated wire.
2. One label with the letter "J".

Description:

1. Cut H9 pin 5 close to the PCB.
2. Connect H9 pin 11 and H9 pin 5 on the component using insulated wire.
3. Connect H6 pin 9, H9 pin 13, O8 pin 13 and O8 pin 12 using insulated wire on the component side of the PCB.
4. Connect O8 pin 9, O8 pin 10 and O8 pin 11 on the component side of the PCB.
5. Connect O8 pin 8 and H9 pin 12 using insulated wire on the component side of the PCB.
6. Update the PCB revision field:
 - 4000 ISS 1: Update to revision J by removing the letter H in the PCB identification field. This is done by placing the label with the letter J on the revision field.
 - 4000 ISS 2: Update to revision F by removing the letter E in the PCB identification field.

Circuits involved:

Name	Type	Position
H6	74F74	A2
H9	74AS32	A2
O8	74AS00	A3

Supermax Field Change Notice no. 95

Module:	DIOC3 4000, ISS 1 and ISS 2
Date:	90.11.29

Category:

- Production change.
- In the field, when booting from a 3½" floppy disk drive or from a dual hosted disk system.

Corrects the error:

- Booting from a 3½" floppy disk on drive 0 (720Kb or 1.44Mb format) is not supported. Only on DIOC3 4000 ISS 2.
- Booting from a dual hosted disk system is not supported.

For further information on dual hosted disk system, see *Supermax technical note no. 17*.

Needed tools:

Hand tools.

Supermax FCN kit 095, stock number 95100950, consisting of:

1. One EPROM labeled "D3BOOT Version 4.0 Date 90.09.01"

Description:

- Replace EPROM device Q1 with EPROM labeled "D3BOOT Version 4.0 Date 90.09.01".

Circuits involved:

Name	Type	Position
Q1	EPROM 27512	L8

Supermax Field Change Notice no. 94

Module: DIOC 4000, ISS 1 and ISS 2.

Date: 90.10.05

Category:

- Production change.
- In the field: When errors occur.

Corrects the error:

- The error is seen, when using the Supermax Diagnostics bus test program as a bus time out. The error results in unpredictable errors or a system crash (display value 00) with the Supermax Operating System.
- This note corrects two problems. The problem originally covered by field change note 90 is also corrected by this note. It is not necessary to make field change note 90, if this note is made.

Needed tools:

Hand tools.

Supermax FCN kit 094, stock number 95100940, consisting of:

1. One PAL labeled "D3162".

Description:

1. Cut the PCB wire on the solder side of the PCB. See the attached page.
2. Connect P5 pin 11 to O6 pin 10 with insulated wire on the component side of the PCB.
3. Change PAL L1 to D3162.
4. Update PCB revision field:
 - 4000 ISS 1: Update to revision H by removing the letter G in the PCB identification field.
 - 4000 ISS 2: Update to revision E by removing the letter D in the PCB identification field.

Circuits involved:

Name	Type	Position
P5	74F74	B4
O6	74F74	B3
L1	D3161	A4

DIOC 4000 ISS 1:

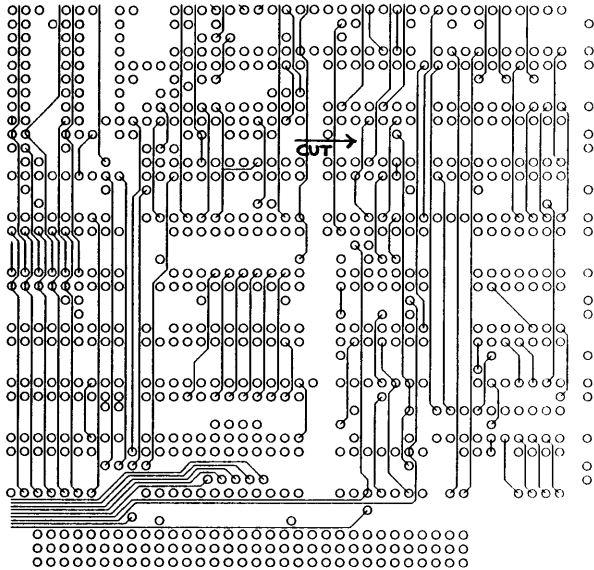

DIOC 4000 ISS 2:

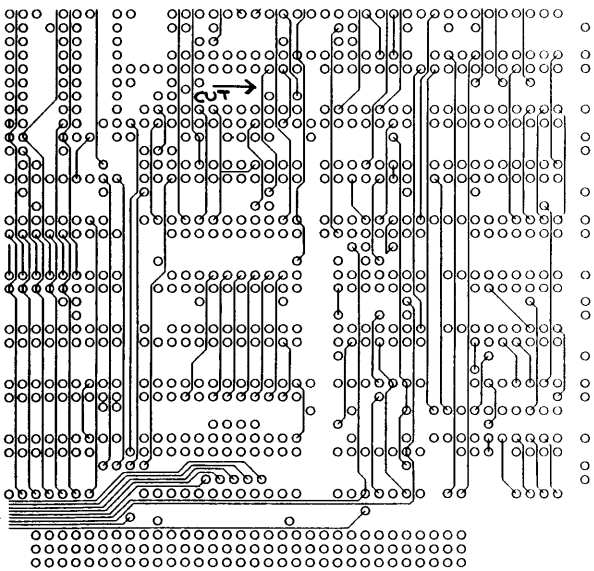

Supermax Field Change Notice no. 92

Module:	DIOC 4000, ISS 1 and 2.
Date:	90.09.05

Category:

- Production change.
- In the field: When two DIOC 4000 modules are connected to the same SCSI cable.

Corrects the error:

- The SCSI interface cable is terminated with resistor-networks at each end of the cable. Power to the resistor-network is provided by the SCSI device which holds the network (DIOC or disk drive) or by the *termination power signal* in the cable.
- The *termination power signal* is used when two DIOC modules are connected to the same cable. Each DIOC module holds a termination networks and both DIOC modules provides the termination power to the cable.
- If one DIOC module loses the power the other DIOC provides the termination power and the SCSI bus is still properly terminated.
- This note describes how to provide correct termination power.

Needed tools:

Hand tools.

Supermax FCN kit 092, stock number 95100920, consisting of:

1. Two 1N5818 diodes.

Description:

1. Replace diode DS3 and DS53 with 1N5818 types.
2. Connect strap ST10 pin 2 to connector CN3 pin 26 with insulated wire on the solder side of the PCB.
3. Strap ST8 provides termination power to SCSI interface 0. Set strap to short between pin 2 and 3.
4. Strap ST10 provides termination power to SCSI interface 1. Set strap to short between pin 2 and 3.
5. Update PCB revision field:
 - 4000 ISS 1: Update to revision G by removing the letter F in the PCB identification field.
 - 4000 ISS 2: Update to revision D by removing the letter C in the PCB identification field.

Circuits involved:

Name	Type	Position
DS3	Diode	C14
DS53	Diode	C14
ST8	Strap	C14
ST10	Strap	C14
CN3	Connector	C14

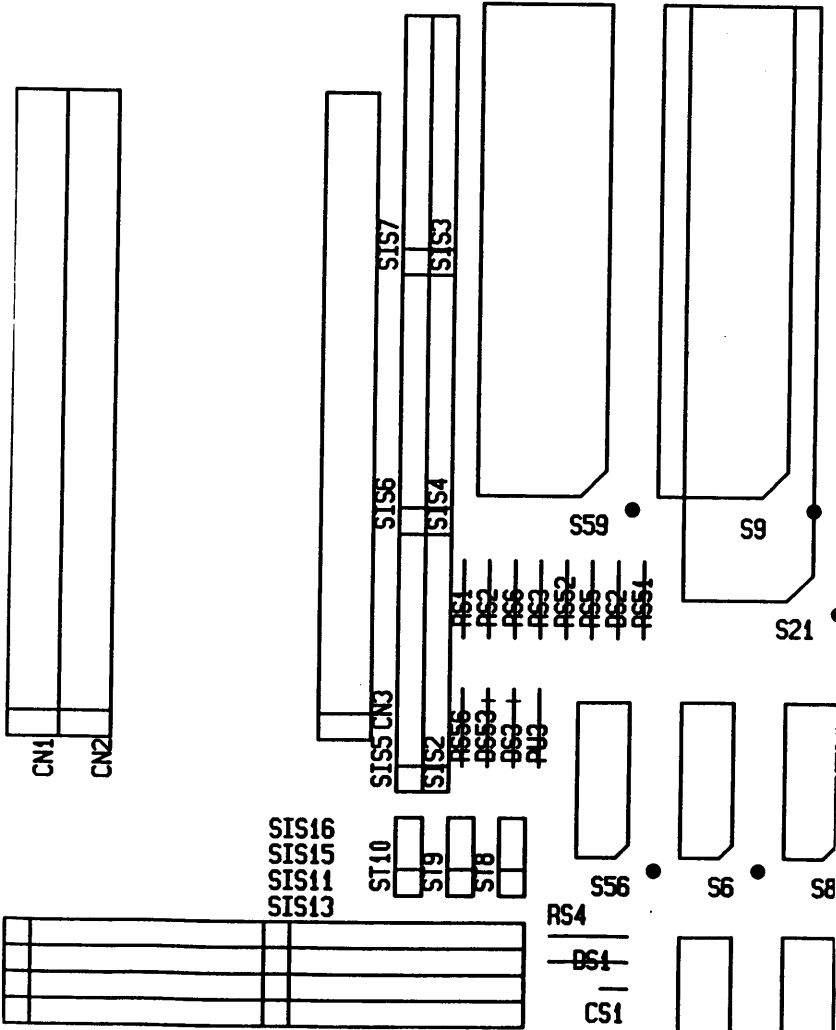

Supermax Field Change Notice no. 91

Module: DIOC 4000, ISS 1.

Date: 90.06.13

Category:

- Production change.
- In the field: When field change note 89 is made.

Corrects the error:

- The error results in a system crash (display value 00) during boot with the Supermax Operating System.

Needed tools:

Hand tools.

Supermax FCN kit 091, stock number 95100910, consisting of:

1. One PAL labeled "D3291"

Description:

1. Change PAL D3290 to D3291.
2. Update to revision F by removing the letter E in the ASSY identification field.

Circuits involved:

Name	Type	Position
T8	D3291	H12

Supermax Field Change Notice no. 90

Module:	DIOC 4000, ISS 1 and ISS 2.
Date:	90.05.30

Category:

- Production change.
- In the field: When errors occur.

Corrects the error:

- The error is seen using the Supermax Diagnostics bus test program as a bus time out. The error results in unpredictable errors or a system crash (display value 00) with the Supermax Operating System.
- The worst case environment is a system with more than one DIOC 4000, few other boards and high VCC, 5.25 Volt. The problem is crosstalk between two signals.

Needed tools:

Hand tools.

Description:

1. Cut the PCB wire two different places on the component side of the PCB. See the attached page.
2. Connect connector CONJ2 pin b3 to the *via* with insulated wire on the component side of the PCB. See the attached page.
3. Update PCB revision field:
 - 4000 ISS 1: Update to revision F by removing the letter E in the PCB identification field.
 - 4000 ISS 2: Update to revision C by removing the letter B in the PCB identification field.

Circuits involved:

Name	Type	Position
CONJ2	Connector	J1

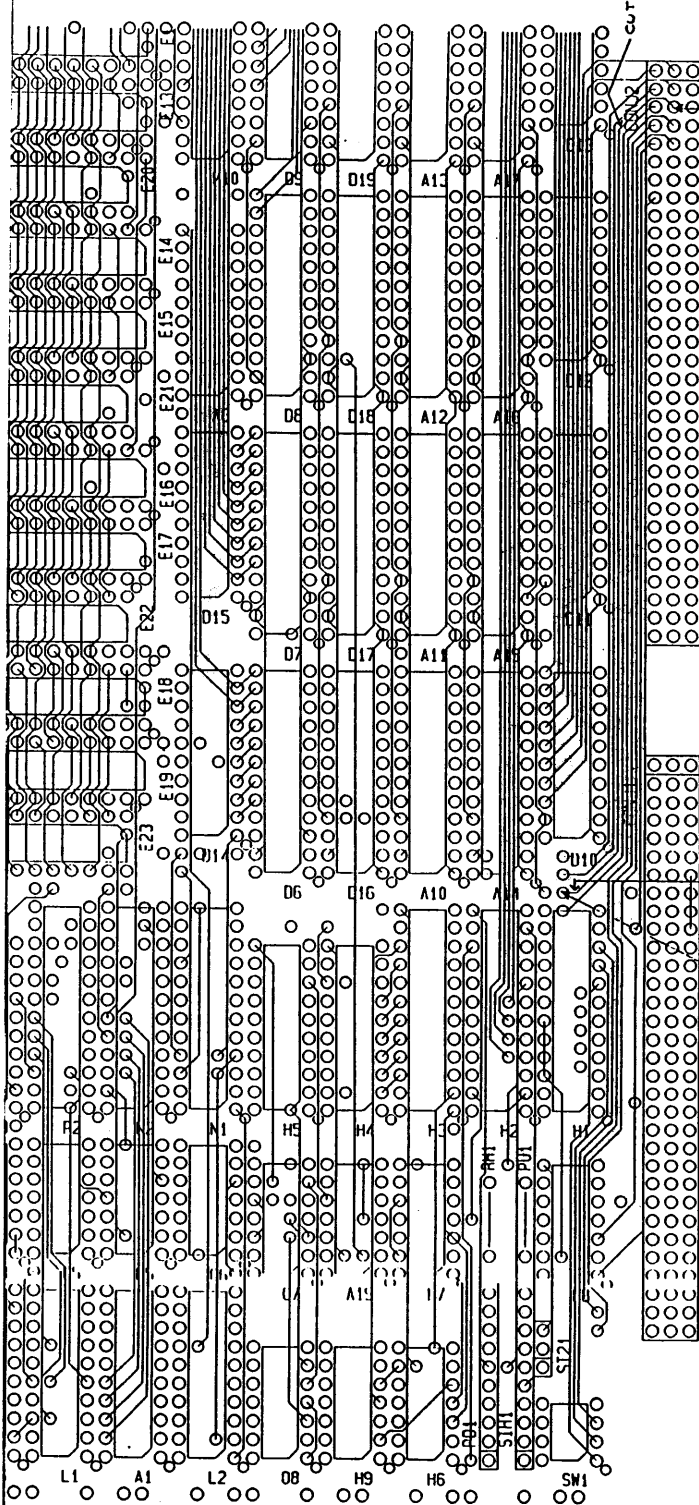

BIOC 4000 IES 1 AND 2
COMPONENT SIDE

CUT
CONNECT WIRE

CUT

VIA
CONNECT WIRE

Supermax Field Change Notice no. 89

Module: DIOC3 4000, ISS 1 and ISS 2

Date: 90.04.24

Category:

- Production change.
- In the field, when booting from the floppy disk drive or from a mirrored/striped disk system.

Corrects the error:

- Booting from the floppy disk drive is not supported. Only on DIOC3 4000 ISS 2.
- Booting from a mirrored/striped disk system is not supported.

For further information, see *Supermax technical note no. 14*.

Needed tools:

Hand tools.

Supermax FCN kit 089, stock number 95100890, consisting of:

1. One EPROM labeled "D3BOOT Version 3.0 Date 90.04.01"

Description:

- Replace EPROM device Q1 with EPROM labeled "D3BOOT Version 3.0 Date 90.04.01".

Circuits involved:

Name	Type	Position
Q1	EPROM 27512	L8

SUPERMAX FIELD CHANGE NOTICE NO. 87

DATE: 900222

MODULE: DIOC3. DDE 4000, ISS 1 and ISS 2.

CATEGORY:

Production change.

In the field: To be made without any unnecessary delay.

CORRECTS THE ERROR:

System hang-up due to an unrecoverable parity error in the diskcache memory.

The content of the diskcache memory is correct but due to a logic hazard an parity error is detected.

NEEDED TOOLS:

Hand tools.

PAL device D3134.

DESCRIPTION:

1. Bend pin 6 on PAL D3153.
2. Bend pin 23 on PAL D3134.
3. Replace PAL D3133 with D3134.
4. Connect PAL D3134 pin 23 with PAL D3153 pin 6 with insulated wire on the componentside of the PCB.
5. Connect PAL D3134 pin 23 to pin 5 with insulated wire on the solder side of the PCB.
6. Update PCB revision field:

dde 4000 ISS 1: Update to revision E by removing the letter D in the PCB identification field.

dde 4000 ISS 2: Update to revision B by removing the letter A in the PCB identification field.

CIRCUITS INVOLVED:

Name:	Type:	Position:
P1	PAL D3133	C5
P2	PAL D3153	C4

SUPERMAX FIELD CHANGE NOTICE NO. 86DATE: 891127MODULE: DIOC 4000CATEGORY:

Production change.

In the field: To be made without any unnecessary delay.

CORRECTS THE ERROR:

System hang-up due to an unrecoverable parity error in the diskcache memory.

NEEDED TOOLS:

Hand tools.

PAL D3112.

DESCRIPTION:

1. Change PAL N2, D3111 to D3112.
2. Update ASSY revision level field to E by removing the letter D in ASSY identification field.

CIRCUITS INVOLVED:

Name: Type: Position:

N2 PAL C4

SUPERMAX FIELD CHANGE NOTICE NO. 84DATE: 890627MODULE: DIOC 4000CATEGORY:

Production change.

In the field: To be made without any unnecessary delay if any Supermax module in the machine is updated with Field Change Note 71-79.

CORRECTS THE ERROR:

System crash 00 due to a bus error on the common I/O bus.

NEEDED TOOLS:

Hand tools.

PAL D3133.

DESCRIPTION:

1. Change PAL P1 to D3133.
2. Update ASSY revision level field to D by removing the letter C in ASSY identification field.

CIRCUITS INVOLVED:

Name:	Type:	Position:
-------	-------	-----------

P1	PAL	C5
----	-----	----

SUPERMAX FIELD CHANGE NOTICE NO. 83

DATE: 890510

MODULE: DIOC 4000

CATEGORY:

Production change.

In the field: To be made when a DIOC 4000 is installed in a Supermax.

To be made before a customer using CPU 4100 is updated with Supermax operating system OS 530.1J.

CORRECTS THE ERROR:

The CPU 4100 supports a new scheme to transfer data across the common Supermax I/O bus. This scheme uses a new backplane signal. This signal is not driven in systems based on CPU boards older than CPU 4100. New operating systems will use the new data transfer mechanism, but this will not work in conjunction with the DIOC 4000, until a strap has been changed. When this strap is placed in one position the DIOC 4000 ignores the new backplane signal. When this strap is in the new position the DIOC 4000 uses the backplane signal as an input.

NEEDED TOOLS:

Hand tools.

Solder station.

Note: The strap may be a piece of wire.

DESCRIPTION:

In the field:

1. DIOC 4000 in a Supermax with CPU 3400.

Strap ST21: Short between pin 1 and 2.

2. DIOC 4000 in Supermax with CPU 4100 or a future CPU module.

Strap ST21: Short between pin 2 and 3.

In the production:

Change component ST21 to a removable strap and use the above rules.

Strap ST21 is placed in position A1, between the unit number switch and component H8.

SUPERMAX FIELD CHANGE NOTICE NO. 80

DATE: 890208

MODULE: DIOC 4000

CATEGORY:

Production change.

In the field: To be made without any unnecessary delay.

CORRECTS THE ERROR:

During a read access to the Supermax I/O bus the internal databus starts to oscillate. The oscillation introduces voltage levels on several PALs above the max. specification. Due to the high voltage levels the PALs fail.

The error is seen with the Supermax Diagnostic Programs as parity errors in the cache memory during the bus test.

The problem results in unpredictable errors with the Supermax Operating System.

TOOLS NEEDED:

Hand tools.

One PAL D3153

One PAL D3111

DESCRIPTION:

1. Change PAL P2 to D3153.
2. Change PAL N2 to D3111.
3. Connect N2 pin 22 to N4 13 with insulated wire on the solder side of the PCB.

4. Update PCB revision level to D by removing the letter C in PCB identification field.

CIRCUITS INVOLVED:

Name:	Type:	Position:
P2	PAL D3153	C4
N2	PAL D3111	C4
N4	74LS541	C6

SUPERMAX FIELD CHANGE NOTICE NO. 79

DATE: 890116

MODULE: 4000 DI0C

CATEGORY:

Production change.

In the field:

When errors occur.

When modules are exchanged or installed in systems with 24 positions.

CORRECTS THE ERROR:

The arbitration signals in the Supermax I/O bus are open collector signals, that are driven by all units in the system.

The rise time of these signals is approximately proportional to the number of units in the system.

In a system with 12 positions the rise time is small enough to leave a large margin.

In a system with 24 positions and many units the rise time is larger and a smaller margin remains.

High temperature and low voltage reduces the margin, and errors may occur in large systems. The errors are usually time out errors.

To improve the margin, the rise time is decreased by reducing the pull-up resistors in systems with 24 positions.

The pull-up resistors are reduced by using two sets of pull-up resistors in parallel, one set in each card cage. The pull-up resistors are located on CPU modules and the changes are described in field change notes 71, 72, and 73.

All units in a Supermax system have one or two drivers, that drive the arbitration signals. All drivers in a system must be changed to drive the reduced pull-up resistors.

The necessary changes for all units are described in field change notes 71 - 79.

All units in a system must be updated according to these notes, when the pull-up resistors are reduced as described in field change notes 71, 72, and 73.

A unit, that is updated, may be used in a system where the pull-up resistors are not reduced.

TOOLS NEEDED:

Hand tools.

2 74AS641

DESCRIPTION:

1. Change IC in position H4 from 74ALS641-1 to 74AS641.
 2. Change IC in position H5 from 74ALS641-1 to 74AS641.
 3. Update ASSY revision level to C by removing the letter B in ASSY identification field.
-

SUPERMAX FIELD CHANGE NOTICE NO. 70

DATE: 890113

MODULE: DIOC 4000

CATEGORY:

Production change.

In the field: To be made without any unnecessary delay.

CORRECTS THE ERROR:

Problems during access to the disk cache memory and the Supermax io bus. The error is seen with the Supermax Diagnostic Programs as read/write errors during cache memory tests and as read/write errors during the bus test. The problem is typically seen when VCC is 5.25 Volt or more.

During an access to the I/O bus or the cache memory and a simultaneous refresh cycle to the local memory bank, the 74AS244 local memory drivers introduce a ground bounce noise effect on the address bus. The noise will result in an illegal address during the cache memory or I/O bus cycle.

The ground bounce effect is seen with very fast drivers and a simultaneous switch from all output high to low. The local memory timing allows the use of slower drivers, i.e. ALS types instead of AS.

The problem will result in unpredictable errors with the Supermax operating system.

TOOLS NEEDED:

Hand tools.

One PAL D3151B.
Three 74ALS244.

DESCRIPTION:

1. Remove PAL D3151 or D3152.
2. Remove the wire between PAL D3152 and P5 pin 1.
2. Insert PAL D3151B in socket P2.
3. Change E3, E4 and E5 from 74AS244 to 74ALS244 types.
4. Update ASSY revision level to B by removing the letter A in ASSY identification field.

Circuits involved:

Name:	Type:	Position:
P5	74F74	B4
P2	PAL D3151	C4
E3	74AS244	K5
E4	74AS244	K6
E5	74AS244	K5

SUPERMAX FIELD CHANGE NOTICE NO. 69DATE: 890103MODULE: DIOC 4000CATEGORY:

Production change.

In the field: To be made without any unnecessary delay.

CORRECTS THE ERROR:

Timing problems during access to the disk cache memory. The error is seen with the Supermax diagnostic programs as read/write errors or parity errors. Seen from the Supermax operating system the system will crash with display code 30 or report a parity error to the service port.

TOOLS NEEDED:

Hand tools.

DESCRIPTION:

1. Cut J11 pin 1 near the PCB.
2. Connect J11 pin 1 to J11 pin 13 with insulated wire on the component side of the PCB.
3. Update PCB revision level to C by removing the letter B in PCB identification field.

Circuits involved:

<u>Name:</u>	<u>Type:</u>	<u>Position:</u>
J11	74AS1004	L13

SUPERMAX FIELD CHANGE NOTICE NO. 68

DATE: 881212

MODULE: DIOC 4000

CATEGORY:

Production change.

In the field: To be made without any unnecessary delay.

CORRECTS THE ERROR:

Timing problems during access to the disk cache memory. The error is seen with the Supermax diagnostic programs as read/write errors or parity errors. Seen from the Supermax operating system the system will crash with display code 30 or report a parity error to the service port.

TOOLS NEEDED:

Hand tools.

One PAL D3070D.

One PAL D3380.

One PAL D3152.

One 74AS573.

One resistor, 33 ohm.

DESCRIPTION:

1. Change PAL M1 D3070 to D3070D.
2. Remove wire from PAL L9 D3370 pin 14.
3. Change PAL L9 D3370 to D3380.
4. Connect wire to D3380 pin 14. The wire connects L9 pin 14 to P5 pin 11.

5. Change PAL P2 D3151 to D3152. Insert D3152 with pin 17 out of the socket.
6. Connect P5 pin 1 to P2 pin 17 with a wire on the component side of the PCB.
7. Change component C17 to a 74AS573 device.
8. Change strap ST6. Remove connection between pin 2 and 3. Connect pin 1 and 2.
9. Cut K8 pin 11.
10. Connect O1 pin 1 to K1 pin 13 with insulated wire on the solder side of the PCB.
11. Cut J11 pin 6 near the PCB, bend the component pin, remove the pin in the PCB and clean the solder from the hole.
12. Connect J11 pin 6 to the component hole through a 33 ohm resistor.
13. Cut J11 pin 5 near the PCB and bend the pin.
14. Connect J11 pin 5 to J12 pin 6 with insulated wire on the component side of the PCB.
15. Update PCB revision level to B by removing the letter A in PCB identification field.

Circuits involved:

Name:	Type:	Position:
M1	PAL D3070	H9
L9	PAL D3370	C4
P5	74F74	B4
P2	PAL D3151	C4
C17	74ALS573	M5

ST6	Strap	M13
K8	74AS32	K9
K1	PAL D3090	H8
O1	74AS21	K8
J11	74AS1004	L13
J12	74AS1004	L14

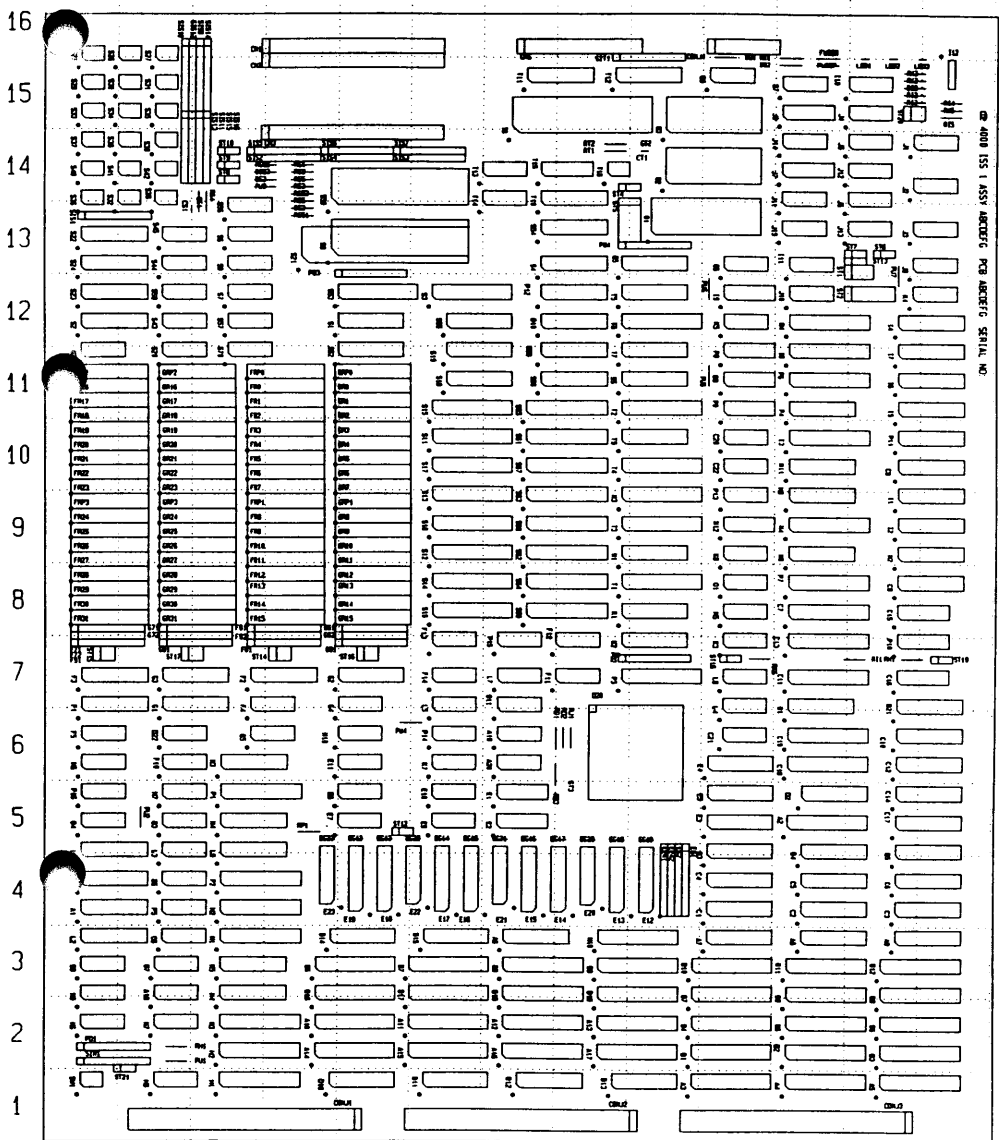

ON FILES DESIGNER ECU 00000000 ASSY 1 551 0000 00

+ A B C D E F G H J K L M N

		gmsa data electronic s/s	
8	878723	4000	
1	861281	Component-ID	
2			
3			
4			
5			

Supermax Field Change Notice no. 99

Module:	NIOC 1600, NIOC 3600, SIOC2 3600
Date:	91.03.08

Category:

- Production change.
- In the field: In case of error.

Corrects the error:

- Loading the NIOC, with operating system or test programs, might result in a parity error.

Needed tools:

Hand tools.

Supermax FCN kit 099, stock number 95100990, consisting of:

1. One PAL labeled "NP141"

Description:

- Replace PAL NP140 device Q7 with PAL labeled "NP141".
- Module 1600 ASSY revision field: Update to revision E by removing the letter D in the ASSY identification field.
- Module 3600 ASSY revision field: Update to revision D by removing the letter C in the ASSY identification field.

Circuits involved:

Name	Type	Position
Q7	PAL NP140	J6

Supermax Field Change Notice no. 88

Module:	NIOC 1600, NIOC 3600, SIOC2 3600
Date:	90.04.24

Category:

- Production change.
- In the field, when operating system named `niocb` must be loaded into the NIOC.

Corrects the error:

- Loading the NIOC with operating system named `niocb` is not supported.

For further information see *Supermax technical note no. 13*.

Needed tools:

Hand tools.

Supermax FCN kit 088, stock number 95100880, consisting of:

1. One EPROM labeled "SNBOOT EVEN Version 2.0 Date 90.04.01"
2. One EPROM labeled "SNBOOT ODD Version 2.0 Date 90.04.01"

Description:

- Replace EPROM device Q1 with EPROM labeled "SNBOOT EVEN Version 2.0 Date 90.04.01".
- Replace EPROM device Q2 with EPROM labeled "SNBOOT ODD Version 2.0 Date 90.04.01".

Circuits involved:

Name	Type	Position
Q1	EPROM 27256	J13
Q2	EPROM 27256	J14

SUPERMAX FIELD CHANGE NOTICE NO. 77

DATE: 890116

MODULE: 1600 NIOC, 3600 NIOC/SIOC

CATEGORY:

Production change.

In the field:

When errors occur.

When modules are exchanged or installed in systems with 24 positions.

CORRECTS THE ERROR:

The arbitration signals in the Supermax I/O bus are open collector signals, that are driven by all units in the system.

The rise time of these signals is approximately proportional to the number of units in the system.

In a system with 12 positions the rise time is small enough to leave a large margin.

In a system with 24 positions and many units the rise time is larger and a smaller margin remains.

High temperature and low voltage reduces the margin, and errors may occur in large systems. The errors are usually time out errors.

To improve the margin, the rise time is decreased by reducing the pull-up resistors in systems with 24 positions.

The pull-up resistors are reduced by using two sets of pull-up resistors in parallel, one set in each card cage. The pull-up resistors are located on CPU modules and the changes are described in field change notes 71, 72, and 73.

All units in a Supermax system have one or two drivers, that drive the arbitration signals. All drivers in a system must be changed to drive the reduced pull-up resistors.

The necessary changes for all units are described in field change notes 71 - 79.

All units in a system must be updated according to these notes, when the pull-up resistors are reduced as described in field change notes 71, 72, and 73.

A unit, that is updated, may be used in a system where the pull-up resistors are not reduced.

TOOLS NEEDED:

Hand tools.

1 74AS641

DESCRIPTION:

1. Change IC in position K2 from 74ALS641-1 to 74AS641.
2. If NIOC 1600, update ASSY revision level to D by removing the letter C in ASSY identification field.

If NIOC/SIOC 3600, update ASSY revision level to C by removing the letter B in ASSY identification field.

SUPERMAX FIELD CHANGE NOTICE NO. 65

DATE: 881123

MODULE: NIOC 1600, NIOC 3600, and SIOC 3600.

CATEGORY:

Production change.

In the field: To be made at a suitable occasion.

CORRECTS THE ERROR:

There is a possibility that the module changes the unit number during the last clock cycle of an access to the I/O bus. If that happens, it may cause an error in another unit connected to the I/O bus.

TOOLS NEEDED:

Hand tools.

DESCRIPTION:

1. Disconnect A0 pin 11 from the PCB by cutting the pin close to the PCB.
2. Connect A0 pin 11 to K7 pin 5 by a wire on the component side of the board.
5. Update PCB revision level:

for NIOC 1600 from E to F by removing the letter E

for NIOC/SIOC 3600 from D to E by removing the letter D.

SUPERMAX FIELD CHANGE NOTICE NO. 64DATE: 881123MODULE: NIOC 1600, NIOC 3600, and SIOC 3600.CATEGORY:

Production change.

In the field: To be made at a suitable occasion.

CORRECTS THE ERROR:

The module may start a wrong access to the I/O bus. This access may cause an error in another unit. The error only occurs after a read modify write cycle from the I/O bus.

TOOLS NEEDED:

Hand tools.

DESCRIPTION:

1. Change PAL in position L1 from NP150 to NP151.
2. Disconnect L2 pin 6 from the PCB by cutting the pin close to the device.
3. Remove the disconnected pin from the PCB.
4. Connect L1 pin 15 to the empty hole L2 pin 6 by a wire on the solder side of the board.
5. Update PCB revision level:

for NIOC 1600 from D to E by removing the letter D

for NIOC/SIOC 3600 from C to D by removing the letter C.

SUPERMAX FIELD CHANGE NOTICE NO. 49DATE: 870714MODULE: NIOC Module 1600. SIOC2 Module 3600CATEGORY:

PRODUCTION CHANGE.

In the Field:
TO BE MADE WHEN ERROR OCCURS.

CORRECTS THE ERROR:

Parity error NIOC/SIOC2 module.

Parity errors in NIOC/SIOC2 have been seen in large Supermax systems with 24 positions motherboard. The parity error may occur when the NIOC/SIOC2 is the active unit in a bus test and tests a DIOC or a SIOC module.

NEEDED TOOLS:

Hand tools

DESCRIPTION:

Disconnect O1 pin 2 and 5 from the PCB and connect these pins to L6 pin 8.

1. Remove 74S00 in position O1.
2. Install 74S00 in position O1 with pin 2 and pin 5 lifted from the printed circuit board.

3. Connect O1 pin 2 and pin 5 to L6 pin 8. Use a thin wire on the component side of the board.

4. Update PCB revision level:

on NIOC 1600 from C to D by removing the letter C.

on SIOC2 3600 from B to C by removing the letter B.

SUPERMAX FIELD CHANGE NOTICE NO. 46DATE: 870518MODULE: NIOC 1600CATEGORY:

Production change.

In the field: To be made when error occurs.

CORRECTS THE ERROR:

The NIOC may have difficulties when writing to the EEPROM.
The problem is a marginal timing when writing to the EEPROM.

NEEDED TOOLS:

Wire.

Soldering iron.

DESCRIPTION:

1. connect Q5 pin 13 to Q0 pin 20.
2. connect Q7 (npl40) pin 13 to Q5 pin 9.
3. connect Q5 pin 5 to Q5 pin 12.
4. connect Q5 pin 10 to Q5 pin 11.
5. disconnect pin 27 on Q0.
4. connect Q5 pin 8 to Q0 27
5. Change revision level to C by removing the letter B in the ASSY identification on the component side of the board.

CIRCUITS INVOLVED:

Name	Type	Position
Q0	eprom	11,1
Q5	741s32	14,2
Q7	pal	10,4

SUPERMAX FIELD CHANGE NOTICE NO. 36DATE: 870105MODULE: NIOC MODULE 1600.CATEGORY:

Production change.

In the field: To be made when an error occurs.

CORRECTS THE ERROR:

The application program sees the LAN as a heavy loaded network. The supermax diagnostic programs reports a time-out during a command or status phase.

The error occurs because the INTEL 82501, S52189 or S552189 step, is delivered with reduced specifications.

NEEDED TOOLS:

Hand tools.

1 resistor 2k7 +- 5%
2 resistors 2k2 +- 5%
2 resistor 5k6 +- 5%
2 capacitor 10 nF ceramic.

1 resistor network 10x-1-272.
2 resistor networks 10x-1-392.

1 IC, SEEQ 8023.

DESCRIPTION:

1. Mount the following componentes:

Name on silkscreen:	Type:	Value:
CRO	Resistor	2k2 +- 5%
CR3	Resistor	5k6 +- 5%
ACO	Capacitor	10 nF ceramic.
CR4	Resistor	2k2 +- 5%
CR7	Resistor	5k6 +- 5%
AC1	Capacitor	10 nF ceramic.

2. Change resistor network SIO to a 10x-1-392 network.
3. Change resistor network SI1 to a 10x-1-272 network.
4. Change resistor network SI2 to a 10x-1-392 network.
5. Change resistor IR6 to a 2k7 +- 5 % resistor.
6. Change Y2, INTEL 82501 S52189 or S552189, to a SEEQ 8023 device.
7. The INTEL 82501 shall be returned to the factory.
8. Straps and jumpers:

AJ9

Pin 1 connected to pin 2: SEEQ 8023 compatible.
 Pin 2 connected to pin 3: INTEL 82501 compatible.

AJA

Pin 1 connected to pin 2: SEEQ 8023 compatible.
 Pin 2 connected to pin 3: INTEL 82501 compatible.

AJB

Pin 1 connected to pin 2: INTEL 82501 compatible.
 Pin 2 connected to pin 3: SEEQ 8023 compatible.

9. Change revision level to B by removing the letter A in the ASSY identification on the component side of the board.

CIRCUITS INVOLVED:

All components are situated near the 16 pin flatcable header.

SUPERMAX FIELD CHANGE NOTICE NO. 35DATE: 861126MODULE: NIOC MODULE 1600.CATEGORY:

Production change.

To be made at a suitable occasion.

CORRECTS THE ERROR:

If bus drivers B8, B9, C0, and C1 are 74ALS646 data errors may occur in bus test program. Bad data is written in the memory of the NIOC from the IO bus.

NEEDED TOOLS:

Hand tools.

DESCRIPTION:

1. Change PAL NP70 position L5 to PAL NP71.
 2. Connect PAL NP71 position L5 pin 16 to PAL NP150 position L1 pin 18.
 3. Change revision level to B by removing the letter A in the PCB identification on the component side of the board.
-

SECTION 1.1

NIOC 3600 1

SIOC 0300/1 2

SIOC 3600 3

MIOC 4600 4

MIOC 4800 5

MIOC SUBMODULES 6

CIOC 0900/1 7

STATUS 8

OTHERS 9

SECTION 2.0 10

Supermax Field Change Notice no. 99

Module: NIOC 1600, NIOC 3600, SIOC2 3600

Date: 91.03.08

Category:

- Production change.
- In the field: In case of error.

Corrects the error:

- Loading the NIOC, with operating system or test programs, might result in a parity error.

Needed tools:

Hand tools.

Supermax FCN kit 099, stock number 95100990, consisting of:

1. One PAL labeled "NP141"

Description:

- Replace PAL NP140 device Q7 with PAL labeled "NP141".
- Module 1600 ASSY revision field: Update to revision E by removing the letter D in the ASSY identification field.
- Module 3600 ASSY revision field: Update to revision D by removing the letter C in the ASSY identification field.

Circuits involved:

Name	Type	Position
Q7	PAL NP140	J6

Supermax Field Change Notice no. 88

Module:	NIOC 1600, NIOC 3600, SIOC2 3600
Date:	90.04.24

Category:

- Production change.
- In the field, when operating system named *niocb* must be loaded into the NIOC.

Corrects the error:

- Loading the NIOC with operating system named *niocb* is not supported.

For further information see *Supermax technical note no. 13*.

Needed tools:

Hand tools.

Supermax FCN kit 088, stock number 95100880, consisting of:

1. One EPROM labeled "SNBOOT EVEN Version 2.0 Date 90.04.01"
2. One EPROM labeled "SNBOOT ODD Version 2.0 Date 90.04.01"

Description:

- Replace EPROM device Q1 with EPROM labeled "SNBOOT EVEN Version 2.0 Date 90.04.01".
- Replace EPROM device Q2 with EPROM labeled "SNBOOT ODD Version 2.0 Date 90.04.01".

Circuits involved:

Name	Type	Position
Q1	EPROM 27256	J13
Q2	EPROM 27256	J14

SUPERMAX FIELD CHANGE NOTICE NO. 77

DATE: 890116

MODULE: 1600 NIOC, 3600 NIOC/SIOC

CATEGORY:

Production change.

In the field:

When errors occur.

When modules are exchanged or installed in systems with 24 positions.

CORRECTS THE ERROR:

The arbitration signals in the Supermax I/O bus are open collector signals, that are driven by all units in the system.

The rise time of these signals is approximately proportional to the number of units in the system.

In a system with 12 positions the rise time is small enough to leave a large margin.

In a system with 24 positions and many units the rise time is larger and a smaller margin remains.

High temperature and low voltage reduces the margin, and errors may occur in large systems. The errors are usually time out errors.

To improve the margin, the rise time is decreased by reducing the pull-up resistors in systems with 24 positions.

The pull-up resistors are reduced by using two sets of pull-up resistors in parallel, one set in each card cage. The pull-up resistors are located on CPU modules and the changes are described in field change notes 71, 72, and 73.

All units in a Supermax system have one or two drivers, that drive the arbitration signals. All drivers in a system must be changed to drive the reduced pull-up resistors.

The necessary changes for all units are described in field change notes 71 - 79.

All units in a system must be updated according to these notes, when the pull-up resistors are reduced as described in field change notes 71, 72, and 73.

A unit, that is updated, may be used in a system where the pull-up resistors are not reduced.

TOOLS NEEDED:

Hand tools.

1 74AS641

DESCRIPTION:

1. Change IC in position K2 from 74ALS641-1 to 74AS641.
2. If NIOC 1600, update ASSY revision level to D by removing the letter C in ASSY identification field.

If NIOC/SIOC 3600, update ASSY revision level to C by removing the letter B in ASSY identification field.

SUPERMAX FIELD CHANGE NOTICE NO. 65DATE: 881123MODULE: NIOC 1600, NIOC 3600, and SIOC 3600.CATEGORY:

Production change.

In the field: To be made at a suitable occasion.

CORRECTS THE ERROR:

There is a possibility that the module changes the unit number during the last clock cycle af an access to the I/O bus. If that happens, it may cause an error in another unit connected to the I/O bus.

TOOLS NEEDED:

Hand tools.

DESCRIPTION:

1. Disconnect A0 pin 11 from the PCB by cutting the pin close to the PCB.
2. Connect A0 pin 11 to K7 pin 5 by a wire on the component side of the board.
5. Update PCB revision level:
for NIOC 1600 from E to F by removing the letter E
for NIOC/SIOC 3600 from D to E by removing the letter D.

SUPERMAX FIELD CHANGE NOTICE NO. 64DATE: 881123MODULE: NIOC 1600, NIOC 3600, and SIOC 3600.CATEGORY:

Production change.

In the field: To be made at a suitable occasion.

CORRECTS THE ERROR:

The module may start a wrong access to the I/O bus. This access may cause an error in another unit. The error only occurs after a read modify write cycle from the I/O bus.

TOOLS NEEDED:

Hand tools.

DESCRIPTION:

1. Change PAL in position L1 from NP150 to NP151.
2. Disconnect L2 pin 6 from the PCB by cutting the pin close to the device.
3. Remove the disconnected pin from the PCB.
4. Connect L1 pin 15 to the empty hole L2 pin 6 by a wire on the solder side of the board.
5. Update PCB revision level:

for NIOC 1600 from D to E by removing the letter D

for NIOC/SIOC 3600 from C to D by removing the letter C.

SUPERMAX FIELD CHANGE NOTICE NO. 52

DATE: 871120

MODULE: SIOC 3600 and NIOC 3600.

CATEGORY:

Production change.

In the field: To be made at a suitable occasion.

CORRECTS THE ERROR:

Erroneous component list.

NEEDED TOOLS:

Hand tools.

Two resistor networks 10x-1-102 (relates to SIOC2 function).

One resistor network 10x-1-331 (relates to SIOC2 function).

Two resistor networks 10x-1-392 (relates to NIOC function).

One resistor network 10x-1-272 (relates to NIOC function).

One resistor 5k6 +- 5%.

One resistor 2k7 +- 5%.

DESCRIPTION:

1. Change resistor CR7 to a 5k6 +- 5 % resistor.
2. Change resistor network SIO to a 10x-1-392 network.
3. Change resistor network SI1 to a 10x-1-272 network.
4. Change resistor network SI2 to a 10x-1-392 network.
5. Change resistor IR6 to a 2k7 +- 5 % resistor.
6. Check that Y2 is a SEEQ 8023 device if it is a NIOC 3600.

7. Change resistor network SI10 to a 10x-1-102 network.
8. Change resistor network SI14 to a 10x-1-331 network.
9. Change resistor network SI15 to a 10x-1-102 network.
10. Change revision level to B by removing the letter A in the ASSY identification on the component side of the board.

CIRCUITS INVOLVED:

All components are situated near the top of the pcb.

SUPERMAX FIELD CHANGE NOTICE NO. 49DATE: 870714MODULE: NIOC Module 1600. SIOC2 Module 3600CATEGORY:

PRODUCTION CHANGE.

In the Field:
TO BE MADE WHEN ERROR OCCURS.

CORRECTS THE ERROR:

Parity error NIOC/SIOC2 module.

Parity errors in NIOC/SIOC2 have been seen in large Supermax systems with 24 positions motherboard. The parity error may occur when the NIOC/SIOC2 is the active unit in a bus test and tests a DIOC or a SIOC module.

NEEDED TOOLS:

Hand tools

DESCRIPTION:

Disconnect O1 pin 2 and 5 from the PCB and connect these pins to L6 pin 8.

1. Remove 74S00 in position O1.
2. Install 74S00 in position O1 with pin 2 and pin 5 lifted from the printed circuit board.

3. Connect O1 pin 2 and pin 5 to L6 pin 8. Use a thin wire on the component side of the board.

4. Update PCB revision level:

on NIOC 1600 from C to D by removing the letter C.

on SIOC2 3600 from B to C by removing the letter B.

SUPERMAX FIELD CHANGE NOTICE NO. 74

DATE: 890116

MODULE: 0300/0301 SIOC

CATEGORY:

Production change.

In the field:

When errors occur.

When modules are exchanged or installed in systems with 24 positions.

CORRECTS THE ERROR:

The arbitration signals in the Supermax I/O bus are open collector signals, that are driven by all units in the system.

The rise time of these signals is approximately proportional to the number of units in the system.

In a system with 12 positions the rise time is small enough to leave a large margin.

In a system with 24 positions and many units the rise time is larger and a smaller margin remains.

High temperature and low voltage reduces the margin, and errors may occur in large systems. The errors are usually time out errors.

To improve the margin, the rise time is decreased by reducing the pull-up resistors in systems with 24 positions.

The pull-up resistors are reduced by using two sets of pull-up resistors in parallel, one set in each card cage. The pull-up resistors are located on CPU modules and the changes are described in field change notes 71, 72, and 73.

All units in a Supermax system have one or two drivers, that drive the arbitration signals. All drivers in a system must be changed to drive the reduced pull-up resistors.

The necessary changes for all units are described in field change notes 71 - 79.

All units in a system must be updated according to these notes, when the pull-up resistors are reduced as described in field change notes 71, 72, and 73.

A unit, that is updated, may be used in a system where the pull-up resistors are not reduced.

TOOLS NEEDED:

Hand tools.

1 74AS641

DESCRIPTION:

1. Change IC in position M2 from 74ALS641-1 to 74AS641.
2. If SIOC 0300, update revision level to D by removing the letter C in the revision level field.

If SIOC 0301, update ASSY revision level to B by removing the letter A in ASSY identification field.

SUPERMAX FIELD CHANGE NOTICE NO. 58DATE: 880920MODULE: SIOC 301.CATEGORY:

Production change.
To be made when error occurs.

CORRECTS THE ERROR:

Due to a missing PCB connection the SIOC is not able to bootstrap with the UNIX operating system 3.

TOOLS NEEDED:

Hand tools.

DESCRIPTION:

1. Connect H3 pin 6 to O1 pin 16 with insulated wire on the component side of the PCB.
2. Update PCB revision level from A to B by removing the letter A in the PCB revision field.

CIRCUIT INVOLVED:

H3 is located in coordinate G9.
O1 is located in coordinate F9.

SUPERMAX FIELD CHANGE NOTICE NO. 29

DATE: 860120

MODULE: SIOC MODULE 0300 and 0301.

CATEGORY:

Production change.

In the field: To be made without any unnecessary delay.

CORRECTS THE ERROR:

Unix environment:

Seen from the user the system is down. Typically the system dies or crashes with a display error code 00.

Supermax diagnostic programs:

The SIOC displays usually the error message ESR 0000 0000.

NEEDED TOOLS:

Hand tools. PAL S32 AND S42.

DESCRIPTION:

1. Cut I5 pin 01 near the PCB.
2. Connect I5 pin 01 to H1 pin 08 with insulated wire on the component side.
3. Change PAL S40 to S42, package K2. Insert S42 in the socket with pin 04 out of the socket.
4. Connect I2 pin 15 to K2 pin 04 with insulated wire on the component side.
5. Cut B8 pin 10 near the PCB.

6. Connect B8 pin 10 to B7 pin 12 with insulated wire on the component side.

If FCN 20 not is made then:

7. Check with ohm-meter the connection between PAL S30, package H7 pin 07 and H5 pin 05.
8. Disconnect H7 pin 07 by cutting wire on the solder side near the pin.
9. Check no-connection between H7 pin 07 and H5 pin 05.
10. Connect H7 pin 07 to PAL S60, package K4 pin 11 with insulated wire on the solder side.
11. Change PAL package H7 from S30 to S32.

If FCN 20 is made then:

12. Remove wire between H7 pin 07 and H6 pin 29.
13. Connect H7 pin 07 to K4 pin 11 with insulated wire on the solder side.
14. Change PAL package H7 from S31 to S32.
15. Change revision level to C by removing the letter B in the PCB identification on the solder side of the board.

CIRCUITS INVOLVED:

Name	Type	Position
I5	74LS00	A 5,5.
H1	74S04	B 4,4.

K2	PAL S40	B	5,3.
I2	74ALS574	B	2,3.
B8	74LS74	A	6,4.
B7	74LS21	A	7,4.
H7	PAL S30	B	3,4.
H6	8085	B	1,4.
H5	74LS74	B	5,4.
K4	PAL S60	B	1,3.

SUPERMAX FIELD CHANGE NOTICE NO. 20

DATE: 850814

MODULE: SIOC MODULE 0300 and 0301

CATEGORY:

PRODUCTION CHANGE.

IN THE FIELD:
TO BE MADE AT A SUITABLE OCCASION.

CORRECTS THE ERROR:

Bug in the arbitration between internal and external memory cycles. The bug is only visible, when the module runs the SUPERMAX diagnostic program "bustest".

NEEDED TOOLS:

HAND TOOLS. PAL S31. Insulated wire.

DESCRIPTION:

Package H6 is LSI 8085, Position B 1,5
Package H7 is PAL S30, Position B 3,4

Disconnect H7 pin 07 by cutting the wire on the solder side close to the pin.

Connect H7-07 to H6-29 with insulated wire on the solder side of the board.

PAL package H7 is changed from S30 to S31.

Change revision level from A to B by removing the letter A in the PCB identification on the solder side of the board.

SUPERMAX FIELD CHANGE NOTICE NO. 5

DATE: 831012.

MODULE: 0300 AND 0301 SIOC MODULE.

CATEGORY:

TO BE MADE AT A SUITABLE OCCASION OR
TO BE MADE WHEN ERROR OCCURS.

CORRECTS THE ERROR:

POSSIBLE TO PRINT OUT ON SERIEL CHANNEL 7 WITHOUT ANY PERIPHERAL
CONNECTED TO THIS CHANNEL.

NEEDED TOOLS:

HAND TOOLS.

DESCRIPTION:

1. REMOVE RESISTOR RT1.
2. REMOVE CAPACITOR CT1.

CIRCUITS INVOLVED:

NAME	TYPE	POSITION
RT1	RESISTOR	B 8,7
CT1	CAPACITOR	B 8,7

THE COMPONENTS ARE SITUATED BETWEEN THE TWO ROWS OF RS-232-C DRIVERS.

Supermax Field Change Notice no. 99

Module: NIOC 1600, NIOC 3600, SIOC2 3600

Date: 91.03.08

Category:

- Production change.
- In the field: In case of error.

Corrects the error:

- Loading the NIOC, with operating system or test programs, might result in a parity error.

Needed tools:

Hand tools.

Supermax FCN kit 099, stock number 95100990, consisting of:

1. One PAL labeled "NP141"

Description:

- Replace PAL NP140 device Q7 with PAL labeled "NP141".
- Module 1600 ASSY revision field: Update to revision E by removing the letter D in the ASSY identification field.
- Module 3600 ASSY revision field: Update to revision D by removing the letter C in the ASSY identification field.

Circuits involved:

Name	Type	Position
Q7	PAL NP140	J6

Supermax Field Change Notice no. 88

Module:	NIOC 1600, NIOC 3600, SIOC2 3600
Date:	90.04.24

Category:

- Production change.
- In the field, when operating system named `niocb` must be loaded into the NIOC.

Corrects the error:

- Loading the NIOC with operating system named `niocb` is not supported.

For further information see *Supermax technical note no. 13*.

Needed tools:

Hand tools.

Supermax FCN kit 088, stock number 95100880, consisting of:

1. One EPROM labeled "SNBOOT EVEN Version 2.0 Date 90.04.01"
2. One EPROM labeled "SNBOOT ODD Version 2.0 Date 90.04.01"

Description:

- Replace EPROM device Q1 with EPROM labeled "SNBOOT EVEN Version 2.0 Date 90.04.01".
- Replace EPROM device Q2 with EPROM labeled "SNBOOT ODD Version 2.0 Date 90.04.01".

Circuits involved:

Name	Type	Position
Q1	EPROM 27256	J13
Q2	EPROM 27256	J14

SUPERMAX FIELD CHANGE NOTICE NO. 77

DATE: 890116

MODULE: 1600 NIOC, 3600 NIOC/SIOC

CATEGORY:

Production change.

In the field:

When errors occur.

When modules are exchanged or installed in systems with 24 positions.

CORRECTS THE ERROR:

The arbitration signals in the Supermax I/O bus are open collector signals, that are driven by all units in the system.

The rise time of these signals is approximately proportional to the number of units in the system.

In a system with 12 positions the rise time is small enough to leave a large margin.

In a system with 24 positions and many units the rise time is larger and a smaller margin remains.

High temperature and low voltage reduces the margin, and errors may occur in large systems. The errors are usually time out errors.

To improve the margin, the rise time is decreased by reducing the pull-up resistors in systems with 24 positions.

The pull-up resistors are reduced by using two sets of pull-up resistors in parallel, one set in each card cage. The pull-up resistors are located on CPU modules and the changes are described in field change notes 71, 72, and 73.

All units in a Supermax system have one or two drivers, that drive the arbitration signals. All drivers in a system must be changed to drive the reduced pull-up resistors.

The necessary changes for all units are described in field change notes 71 - 79.

All units in a system must be updated according to these notes, when the pull-up resistors are reduced as described in field change notes 71, 72, and 73.

A unit, that is updated, may be used in a system where the pull-up resistors are not reduced.

TOOLS NEEDED:

Hand tools.

1 74AS641

DESCRIPTION:

1. Change IC in position K2 from 74ALS641-1 to 74AS641.
2. If NIOC 1600, update ASSY revision level to D by removing the letter C in ASSY identification field.

If NIOC/SIOC 3600, update ASSY revision level to C by removing the letter B in ASSY identification field.

SUPERMAX FIELD CHANGE NOTICE NO. 65

DATE: 881123

MODULE: NIOC 1600, NIOC 3600, and SIOC 3600.

CATEGORY:

Production change.

In the field: To be made at a suitable occasion.

CORRECTS THE ERROR:

There is a possibility that the module changes the unit number during the last clock cycle of an access to the I/O bus. If that happens, it may cause an error in another unit connected to the I/O bus.

TOOLS NEEDED:

Hand tools.

DESCRIPTION:

1. Disconnect A0 pin 11 from the PCB by cutting the pin close to the PCB.

2. Connect A0 pin 11 to K7 pin 5 by a wire on the component side of the board.

5. Update PCB revision level:

for NIOC 1600 from E to F by removing the letter E

for NIOC/SIOC 3600 from D to E by removing the letter D.

SUPERMAX FIELD CHANGE NOTICE NO. 64

DATE: 881123

MODULE: NIOC 1600, NIOC 3600, and SIOC 3600.

CATEGORY:

Production change.

In the field: To be made at a suitable occasion.

CORRECTS THE ERROR:

The module may start a wrong access to the I/O bus. This access may cause an error in another unit. The error only occurs after a read modify write cycle from the I/O bus.

TOOLS NEEDED:

Hand tools.

DESCRIPTION:

1. Change PAL in position L1 from NP150 to NP151.
2. Disconnect L2 pin 6 from the PCB by cutting the pin close to the device.
3. Remove the disconnected pin from the PCB.
4. Connect L1 pin 15 to the empty hole L2 pin 6 by a wire on the solder side of the board.
5. Update PCB revision level:

for NIOC 1600 from D to E by removing the letter D

for NIOC/SIOC 3600 from C to D by removing the letter C.

SUPERMAX FIELD CHANGE NOTICE NO. 52

DATE: 871120

MODULE: SIOC 3600 and NIOC 3600.

CATEGORY:

Production change.

In the field: To be made at a suitable occasion.

CORRECTS THE ERROR:

Erroneous component list.

NEEDED TOOLS:

Hand tools.

Two resistor networks 10x-1-102 (relates to SIOC2 function).

One resistor network 10x-1-331 (relates to SIOC2 function).

Two resistor networks 10x-1-392 (relates to NIOC function).

One resistor network 10x-1-272 (relates to NIOC function).

One resistor 5k6 +- 5%.

One resistor 2k7 +- 5%.

DESCRIPTION:

1. Change resistor CR7 to a 5k6 +- 5 % resistor.
2. Change resistor network SIO to a 10x-1-392 network.
3. Change resistor network SI1 to a 10x-1-272 network.
4. Change resistor network SI2 to a 10x-1-392 network.
5. Change resistor IR6 to a 2k7 +- 5 % resistor.
6. Check that Y2 is a SEEQ 8023 device if it is a NIOC 3600.

7. Change resistor network SI10 to a 10x-1-102 network.
8. Change resistor network SI14 to a 10x-1-331 network.
9. Change resistor network SI15 to a 10x-1-102 network.
10. Change revision level to B by removing the letter A in the ASSY identification on the component side of the board.

CIRCUITS INVOLVED:

All components are situated near the top of the pcb.

SUPERMAX FIELD CHANGE NOTICE NO. 49DATE: 870714MODULE: NIOC Module 1600. SIOC2 Module 3600CATEGORY:

PRODUCTION CHANGE.

In the Field:
TO BE MADE WHEN ERROR OCCURS.

CORRECTS THE ERROR:

Parity error NIOC/SIOC2 module.

Parity errors in NIOC/SIOC2 have been seen in large Supermax systems with 24 positions motherboard. The parity error may occur when the NIOC/SIOC2 is the active unit in a bus test and tests a DIOC or a SIOC module.

NEEDED TOOLS:

Hand tools

DESCRIPTION:

Disconnect O1 pin 2 and 5 from the PCB and connect these pins to L6 pin 8.

1. Remove 74S00 in position O1.
2. Install 74S00 in position O1 with pin 2 and pin 5 lifted from the printed circuit board.

3. Connect O1 pin 2 and pin 5 to L6 pin 8. Use a thin wire on the component side of the board.

4. Update PCB revision level:

on NIOC 1600 from C to D by removing the letter C.

on SIOC2 3600 from B to C by removing the letter B.

SUPERMAX FIELD CHANGE NOTICE NO. 45

DATE: 870518

MODULE: SIOC2 3600

CATEGORY:

Production change.

In the field: To be made when error occurs.

CORRECTS THE ERROR:

The SIOC2 may have difficulties when writing to the EEPROM.
The problem is a marginal timing when writing to the EEPROM.

NEEDED TOOLS:

Wire.

Soldering iron.

DESCRIPTION:

1. connect Q5 pin 13 to Q0 pin 20.
2. connect Q7 (npl40) pin 13 to Q5 pin 9.
3. connect Q5 pin 5 to Q5 pin 12.
4. connect Q5 pin 10 to Q5 pin 11.
5. disconnect pin 27 on Q0.
4. connect Q5 pin 8 to Q0 27
5. Change revision level to B by removing the letter A in the
ASSY identification on the component side of the board.

CIRCUITS INVOLVED:

Name	Type	Position
Q0	eeeprom	11,1
Q5	741s32	14,2
Q7	pal	10,4

Supermax Field Change Notice no. 123

Module:	MIOC 4Mb module, PCB 4600 ISS 2. FCN no 1. MIOC 2Mb module, PCB 4600 ISS 2. FCN no 1. (Production only)
Date:	93-01-19

NOTE: This FCN replaces FCN119 in the production only.

Category:

- Production change.
- In the field, if error occurs.

Corrects the error:

- Hazardous timing of various control signals.

Needed tools:

Hand tools.

Supermax FCN kit 123, stock number 95101230, consisting of:

1. One PAL labeled "MX322".
2. One PAL labeled "MX1151".

Description:

1. Change the PAL in X115 from MX1150 to MX1151.
2. Remove the PAL MX320 in X32.
3. Mount the PAL MX322 in X32 with pin 12, pin 15, pin 16 and pin 19 out of the socket.
4. Connect X32 pin 15 and 68030 pin G1 using insulated wire on the component side of the PCB. (See the attached drawing concerning 68030 pin numbering.)
5. Connect X32 pin 16 and 68030 pin J1 using insulated wire on the component side of the PCB. (See the attached drawing concerning 68030 pin numbering.)
6. Connect X32 pin 12 and X116 pin 13 using insulated wire on the component side of the PCB.
7. Connect X32 pin 19 and X54 pin 13 using insulated wire on the component side of the PCB.
8. Update the ASSY revision field from A to B by removing the letter A.

Circuits involved:

Name	Type	Position
X32	PAL	C5
X54	PAL	C5
X116	PAL	C5
X115	PAL	L3
68030	CPU	G6

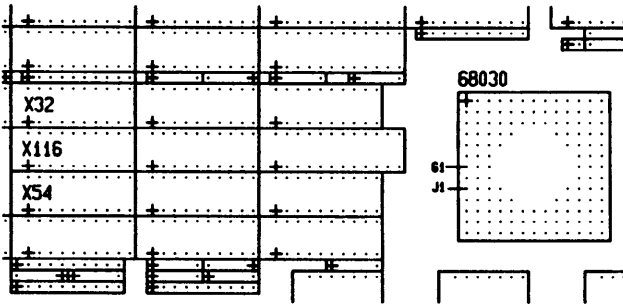

Board layout details 4600.

Supermax Field Change Notice no. 134

Module:	MIOC4600-2Mb, PCB 4600 ISS 2. FCN no 4. MIOC4600-4Mb, PCB 4600 ISS 2. FCN no 4.
Date:	93-07-15

Category:

- Production change.
- In the field, if error occurs or at a suitable occasion.

Corrects the error:

- Because of noise on the I/O bus address lines, generated by the MIOC, an internal memory access is terminated, returning wrong data to the MIOC.
The error is seen as various system crash on the MIOC, indicating that the MIOC has read wrong data.

Needed tools:

Hand tools.

Supermax FCN kit 134, stock number 95101340, consisting of:

1. One PAL labeled "MX022".
2. 25 cm insulated wire.

Description:

1. Remove PAL MX021 from the socket X02.
2. Install PAL MX022 in X02 with pin 13 outside the socket.
3. Connect X02 (MX022) pin 13 and X03 (MX030) pin 2 using insulated wire on the component side of the PCB.
4. Update the ASSY revision field from C to D by removing the letter C.

Circuits involved:

Name	Type	Position
X02	PAL	J4
X03	PAL	D5

Supermax Field Change Notice no. 133

Module:	MIOC4600-2Mb, PCB 4600 ISS 2. FCN no 3. MIOC4600-4Mb, PCB 4600 ISS 2. FCN no 3.
Date:	93-06-28

Category:

- Production change.
- In the field, if error occurs.

Corrects the error:

- Due to a component type mismatch, one pin on the MC68030 microprocessor is connected to a signal on the PCB, even though the pin is marked "Do not connect". The effect of this error is unpredictable.

Needed tools:

Hand tools.

Description:

1. Carefully remove the MC68030 from the socket.
2. Remove pin F10 from the socket and carefully cut F10 on the processor.
3. Carefully insert the MC68030 into the socket.
4. Update the ASSY revision field from B to C by removing the letter B.

Circuits involved:

Name	Type	Position
68030	MC68030	G6

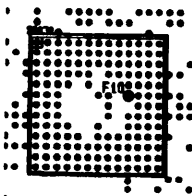

MIOC4600 Board layout. Component side

Supermax Field Change Notice no. 126

Module:	MIOC4800-2Mb, PCB 4600 ISS 2. FCN no 2. MIOC4800-4Mb, PCB 4600 ISS 2. FCN no 2.
Date:	93-02-03

Category:

- Production change.
- In the field, if error occurs.

Corrects the error:

- Timeout problems on the MIOC. The time before timeout is increased from 100 μ s to 500 μ s. The error is seen as various system crash error codes.

Needed tools:

Hand tools.
Small piece of wire.

Description:

1. Cut the connection between X102 pin 12 and X101 pin 4 on the solder side of the PCB.
2. Connect X102 pin 12 and X101 pin 6 using a small piece of wire on the component side of the PCB.
3. Update the PCB revision field from A to B by removing the letter A.

Circuits involved:

Name	Type	Position
X101	74LS390	B6
X102	74LS390	B6

Supermax Field Change Notice no. 119

Module:	MIOC 2Mb module, PCB 4600 ISS 2. FCN no 1.
Date:	92-12-15

Category:

- Production change.
- In the field, if error occurs.

Corrects the error:

- Hazardous timing of various control signals.

Needed tools:

Hand tools.

Supermax FCN kit 119, stock number 95101190, consisting of:

1. One PAL labeled "MX321".
2. One PAL labeled "MX1151".

Description:

1. Change the PAL in X32 from MX320 to MX321.
2. Change the PAL in X115 from MX1150 to MX1151.
3. Update the ASSY revision field from A to B by removing the letter A.

Circuits involved:

Name	Type	Position
X32	PAL	C5
X115	PAL	L3

Supermax Field Change Notice no. 148

Module:	MIOC4800-2Mb, PCB 4800 ISS 1. MIOC4800-8Mb, PCB 4800 ISS 1.
Date:	95-08-14

Category:

- Production change.
- In the field, if error occurs.

Corrects the error:

Eliminates spurious faults caused by too high signal levels on some clock lines.

Needed tools:

Hand tools.

Supermax FCN kit 148, stock number 95101480, consisting of:

1. Five resistors, 220 ohm.
2. Five resistors, 330 ohm.

Description:

- Connect a 220 ohm resistor from X63 pin 20 to X63 pin 11 and connect a 330 Ohm resistor from X63 pin 10 to X63 pin 11.
Connect a 220 ohm resistor from X02 pin 24 to X02 pin 1 and connect a 330 Ohm resistor from X02 pin 12 to X02 pin 1.
Connect a 220 ohm resistor from X115 pin 20 to X115 pin 1 and connect a 330 Ohm resistor from X115 pin 10 to X115 pin 1.
Connect a 220 ohm resistor from X34 pin 20 to X34 pin 1 and connect a 330 Ohm resistor from X34 pin 10 to X34 pin 1.
Connect a 220 ohm resistor from X40 pin 20 to X40 pin 1 and connect a 330 Ohm resistor from X40 pin 10 to X40 pin 1.
- Update the revision field by removing the letter B.
New field should be REV: __CDEFGHIJK

Circuits involved:

Name	Type
X02	PAL22V10
X34	PAL16R4
X40	PAL16R6
X63	74AS573
X115	GAL16V8

Previous FCN:

FCN139.

Supermax Field Change Notice no. 139

Module:	MIOC4800-2Mb, PCB 4800 ISS 1. FCN no 1. MIOC4800-8Mb, PCB 4800 ISS 1. FCN no 1.
Date:	94-04-18

Category:

- Production change.
- In the field, if error occurs.

Corrects the error:

The manufacturer of the P74FCT481 parity checker/generator has decided to discontinue this product.

In addition, the parity circuit has been noise sensitive, introducing faulty parity errors.

This FCN will remove the parity circuit from the board. This means that Diagnostic Programs version 5.2 or earlier, can not be used to test the updated MIOC4800. Diagnostic Programs version 5.2.1 or later should be used.

Needed tools:

Hand tools.

Description:

- Production:
1. Do not mount XN7 and XN8.
 2. Do not mount D0P0, D0P1, D0P2, D0P3, D1P0, D1P1, D1P2, and D1P3.
 3. Update the revision field by removing the letter A.
New field should be REV: BCDEFGHIJK

- In the field:
1. Remove XN7 and XN8 from the board.
 2. Update the revision field by removing the letter A.
New field should be REV: BCDEFGHIJK

Circuits involved:

Name	Type	Position
XN7	74FCT481	E4
XN8	74FCT481	H4
D0P0	DRAM	D3
D0P1	DRAM	D3
D0P2	DRAM	D3
D0P3	DRAM	D4
D1P0	DRAM	C3
D1P1	DRAM	C3
D1P2	DRAM	C3
D1P3	DRAM	C4

Supermax Field Change Notice no. 151

Module:	ISDN 30 Channel, PCB 4690 ISS 2.
Date:	95-09-19

Category:

- Production change.
- In the field, if error occurs.

Corrects the error:

On early versions of the AT&T T7230 controller IC the CRC4 check is not implemented correctly. This only affects the primary rate transmissions and has been corrected in the latest version of the chip.

Needed tools:

Hand tools, 68 pin PLCC extraction tool.

Supermax FCN kit 151, stock number 95101510, consisting of:

1. One 68 pin PLCC T7230 ML3 controller IC.

Description:

- IC17 is to be replaced with the new chip T7230 ML3.
- Update the assembly field by removing the letter A.
New field should be ASSY: _BCDEF

Circuits involved:

Name	Type
IC17	T7230-MC

Previous FCN:

None.

Supermax Field Change Notice no. 117

Module:	HDLC submodule, PCB 4640 Iss. 1, 2 and 3. FCN no 3.
Date:	92-12-02.

Category:

- Production change.
- In the field, if error occurs.

Corrects the error:

- The HDLC module is blocking the V24/V28 interface lines during the reset sequence of the system.

Needed tools:

Hand tools.

Supermax FCN kit 117, stock number 95101170, consisting of:

1. 15 cm of insulated wire.
2. One PAL labeled "HDC043"

Description:

1. Cut IC15 pin 9 and IC15 pin 19.
2. Connect IC20 pin 4 and IC22 pin 14 using insulated wire on the solder side of the PCB.
3. Connect IC24 pin 12 and IC23 pin 14 using insulated wire on the solder side of the PCB.
4. Replace PAL HDC042 with HDC043.
This will change the software readable revision field from 2 to 3.
5. Update the PCB revision field:
PCB 4640 Iss 1 and 2: Update to revision C by removing the letter B in the PCB identification field.
PCB 4640 Iss 3: Update to revision B by removing the letter A in the PCB identification field.

Circuits involved:

Name	Type	Position
IC15	74LS273	C3
IC20	75C188	E5
IC24	75C188	C5

Supermax Field Change Notice no. 113

Module:	TERM32 box / TERM322 serial port panel.
Date:	92-08-21
Module FCN no:	1

Category:

- Production change.
- In the field: To be made if error occurs.

Corrects the error:

- Distorted characters or in some cases break down of communication.
- The problem has been seen when using long cables with the Facit A3400 (DDE 700/710).

Note. The TERM32 is specified to be able to run 19.2 kbit with up to 50 m cable.

Needed tools:

Hand tools.

Supermax FCN kit 113, stock number 95101130, consisting of:

- 32 pcs AD238JN receiver/transmitter circuits

Description:

- Replace the receiver/transmitter circuits with the new ones. TERM32 box has 32 of these, all placed in sockets IC16-IC47.
- Update the ASSY revision field:
Update to revision B by removing the letter A in the ASSY identification field.

Supermax Field Change Notice no. 110

Module:	HDLC submodule, PCB 4640 Iss. 1, 2 and 3.
Date:	92-04-29

Category:

- Production change.
- In the field, without any unnecessary delay.

Corrects the error:

- The HDLC module does not work correctly, when other submodules are connected to the MIOC.

Needed tools:

Hand tools.

Supermax FCN kit 110, stock number 95101100, consisting of:

1. One PAL labeled "HDC011"
2. One PAL labeled "HDC042"

Description:

1. Replace PAL HDC010 with HDC011.
2. Replace PAL HDC041 with HDC042.
This will change the software readable revision field from 1 to 2.
3. Update the ASSY revision field:
Update to revision B by removing the letter A in the ASSY identification field.

Circuits involved:

Name	Type	Position
IC9	PAL	A1
IC12	PAL	C2

Supermax Field Change Notice no. 108

Module: HDLC submodule, PCB 4640 Iss. 1 and Iss. 2.

Date: 92-02-07

Category:

- Production change.

Corrects the error:

- Inverted receive and transmit clocks on the V.24/V.28 interface.

Needed tools:

Hand tools.

Supermax FCN kit 108, stock number 95101080, consisting of:

1. One 74LS38.
2. One resistor network 7 × 1K with new name RS12.
3. One PAL labeled "HDC041"
4. 40 cm insulated wire.

Description:

1. Remove IC18 74LS126 from the PCB. Install the 74LS38 in IC18.
2. Cut pin 2, 5 and 8 on RS12 before mounting. Mount the resistor network RS12 on the component side of the PCB on top of IC18. Make the following connections:
 - IC18 pin 14 and RS12 pin 1.
 - IC18 pin 11 and RS12 pin 4.
 - IC18 pin 8 and RS12 pin 7.
 - IC18 pin 3 and RS12 pin 3 using insulated wire.
 - IC18 pin 6 and RS12 pin 6 using insulated wire.
3. Cut the wire on the solder side of the PCB at the two locations indicated on the attached drawing.
4. Make the following connections on the component side of the PCB:
 - IC19 pin 13 and IC18 pin 3 using insulated wire.
 - IC19 pin 12 and IC21 pin 5 using insulated wire.
 - IC19 pin 11 and IC18 pin 8 using insulated wire.
 - IC19 pin 10 and IC25 pin 5 using insulated wire.
5. Replace PAL HDC040 with HDC041.
This will change the software readable revision field from 0 to 1.
6. Update the PCB revision field:
Update to revision B by removing the letter A in the PCB identification field.

Circuits involved:

Name	Type	Position
IC18	74LS126	F2
IC19	74LS04	A4
IC21	75C188	E5
IC25	75C188	C5

Solder side PCB layout.

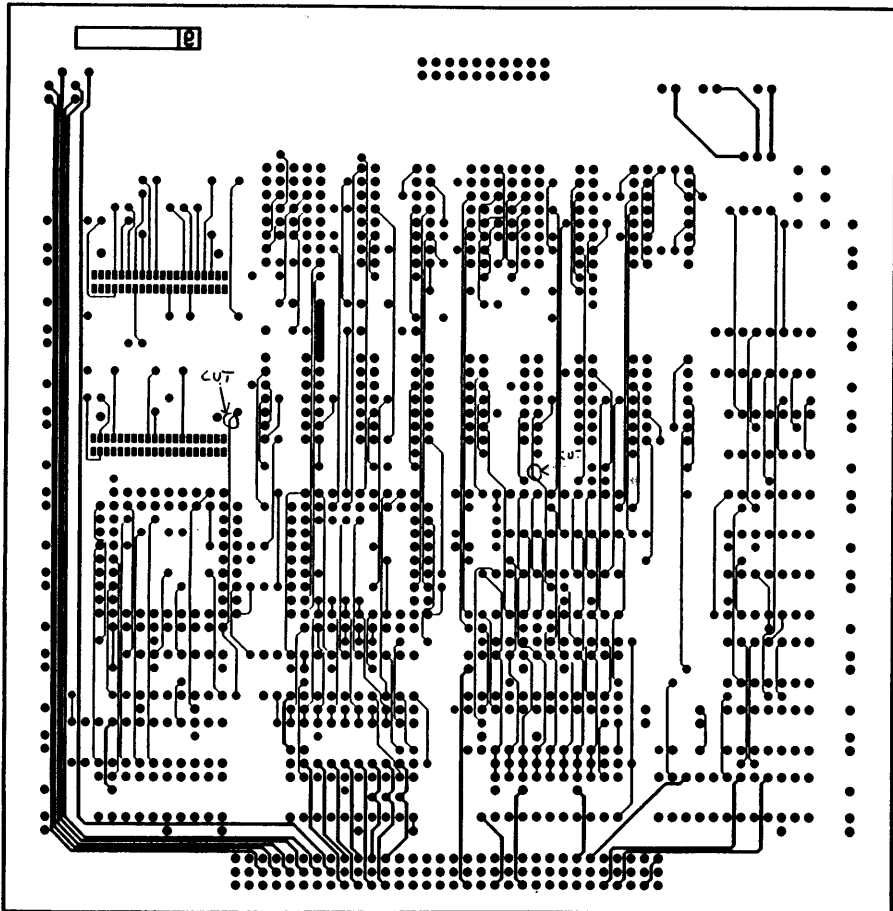

SUPERMAX FIELD CHANGE NOTICE NO. 76

DATE: 890116

MODULE: 0900/0901 CIOC

CATEGORY:

Production change.

In the field:

When errors occur.

When modules are exchanged or installed in systems with 24 positions.

CORRECTS THE ERROR:

The arbitration signals in the Supermax I/O bus are open collector signals, that are driven by all units in the system.

The rise time of these signals is approximately proportional to the number of units in the system.

In a system with 12 positions the rise time is small enough to leave a large margin.

In a system with 24 positions and many units the rise time is larger and a smaller margin remains.

High temperature and low voltage reduces the margin, and errors may occur in large systems. The errors are usually time out errors.

To improve the margin, the rise time is decreased by reducing the pull-up resistors in systems with 24 positions.

The pull-up resistors are reduced by using two sets of pull-up resistors in parallel, one set in each card cage. The pull-up resistors are located on CPU modules and the changes are described in field change notes 71, 72, and 73.

All units in a Supermax system have one or two drivers, that drive the arbitration signals. All drivers in a system must be changed to drive the reduced pull-up resistors.

The necessary changes for all units are described in field change notes 71 - 79.

All units in a system must be updated according to these notes, when the pull-up resistors are reduced as described in field change notes 71, 72, and 73.

A unit, that is updated, may be used in a system where the pull-up resistors are not reduced.

TOOLS NEEDED:

Hand tools.

2 74AS641

DESCRIPTION:

1. Change IC in position N2 from 74ALS641-1 to 74AS641.
 2. Change IC in position N4 from 74ALS641-1 to 74AS641.
 3. Update ASSY revision level to D by removing the letter C in ASSY identification field.
-

SUPERMAX FIELD CHANGE NOTICE NO. 60

DATE: 881020

MODULE: CIOC 0900 and 0901

CATEGORY:

Production change.
To be made at a suitable occasion.

CORRECTS THE ERROR:

Due to tristate levels on the internal address bus during DMA cycles the address decoding logic asserts illegal select signals. The internal address bus is pulled up during DMA cycles with resistor network SH1.

The error is seen as read/write errors with the diagnostic programs running bus test.

TOOLS NEEDED:

Hand tools.
Single inline resistor network, 3k3 Kohm. Ex. 10x-1-332.

DESCRIPTION:

1. Insert resistor network SH1.
2. Update ASSY revision level on CIOC 0900 from B to C by removing the letter B in the ASSY revision field.
3. Update ASSY revision level on CIOC 0901 from B to C by removing the letter B in the ASSY revision field.

CIRCUIT INVOLVED:

SH1 is located near LSI device Q9, AM9517, pin 20.

SUPERMAX FIELD CHANGE NOTICE NO. 39

DATE: 870310.

MODULE: CIOC MODULE 0901.

CATEGORY:

Production change.

In the field: To be made when error occurs.

CORRECTS THE ERROR:

The clear to send signal, CTS, is missing when the data-communication protocol is based on the RS-422 interface.

TOOLS NEEDED:

Hand tools.

DESCRIPTION:

1. Check with a ohm-meter the connection between W4 pin 17 and U1 pin 10.
2. Disconnect W4 pin 17 by cutting the wire near the pin on the solder side of the PCB.
3. Check no-connection between W4 pin 17 and U1 pin 10.
4. Connect W4 pin 17 to W5 pin 30 with insulated wire on the solder side of the PCB.
5. Take V4 out of the socket, bend pin 17 and insert the component in the socket.

6. Connect V4 pin 17 to V5 pin 30 with insulated wire on the component side of the PCB.

7. Change revision level to B by removing the letter A in the PCB identification on the component side of the board.

CIRCUITS INVOLVED:

Name	Type	Position
W4	8251, USART	C 10,8
W5	8273, HDLC	C 11,9
U1	74LS08	C 9,10
V4	8251, USART	C 5,10
V5	8273, HDLC	C 5,8

SUPERMAX FIELD CHANGE NOTICE NO. 38DATE: 870223MODULE: CIOC MODULE 0900 and 0901.CATEGORY:

Production change.

In the field: To be made when error occurs.

CORRECTS THE ERROR:

The carrier detect signal is lost when the data-communication protocol is based on HDLC communication in conjunction with the RS-422 interface.

NEEDED TOOLS:

Hand tools.
Two 4K7 resistors.

DESCRIPTION:

1. Mount resistor RU10. RU10 pin 1 is connected to U10 pin 14. RU10 pin 2 is connected to U10 pin 5.
2. Mount resistor RU12. RU12 pin 1 is connected to U10 pin 14. RU12 pin 2 is connected to U10 pin 9.
3. Change revision level to B by removing the letter A in the ASSY identification on the component side of the board.

CIRCUITS INVOLVED:

Name	Type	Position
------	------	----------

RU10	resistor	C	1,6
RU12	resistor	C	3,6
U10	75189	C	2,6

SUPERMAX FIELD CHANGE NOTICE NO. 33

DATE: 860901

MODULE: CIOC MODULE 0900.

CATEGORY:

Production change.

In the field: To be made when error occurs.
To be made at a suitable occasion.

CORRECTS THE ERROR:

Unix environment:

The error occurs only when running the SNA protocol.

Seen from the user the system is down. Typically the system dies or crashes with a display error code 00 during the boot--procedure. The CIOC turns LED 4 and LED 1 on.

Supermax Diagnostic Program shows no errors.

NEEDED TOOLS:

Hand tools. PAL CC61.

DESCRIPTION:

1. Check with ohm-meter the connection between PAL CC60, package O4 pin 11 and Q8 pin 06.
2. Disconnect O4 pin 11 by cutting wire on the solder side near the pin.
3. Check no-connection between O4 pin 11 and Q8 pin 06.

4. Connect O4 pin 11 to Q5 pin 12 with insulated wire on the solder side.
5. Change PAL package O4 from CC60 to CC61.
6. Change revision level to F by removing the letter E in the PCB identification on the component side of the board.

CIRCUITS INVOLVED:

Name	Type	Position
O4	PAL CC60	A 6,6.
Q8	74LS08	B 3,8.
Q5	74LS74	A 9,9.

SUPERMAX FIELD CHANGE NOTICE NO. 30

DATE: 860120

MODULE: CIOC MODULE 0900.

CATEGORY:

Production change.

In the field: To be made without any unnecessary delay.

CORRECTS THE ERROR:

Unix environment:

Seen from the user the system is down. Typically the system dies or crashes with a display error code 00.

Supermax diagnostic programs:

The CIOC displays usually the error message ESR 0000 0000.

NEEDED TOOLS:

Hand tools. PAL CC32 and CC32.

DESCRIPTION:

1. Cut L7 pin 09 near the PCB.
2. Connect L7 pin 09 to P4 pin 08 with insulated wire on the component side.
3. Change PAL CC40 to CC42, package 02. Insert CC42 in the socket with pin 04 out of the socket.
4. Connect I5 pin 16 to O2 pin 04 with insulated wire on the component side.
5. Cut M4 pin 10 near the PCB.

6. Connect M4 pin 10 to M3 pin 05 with insulated wire on the component side.

If FCN 22 not is made then:

7. Check with ohm-meter the connection between PAL CC30, package P2 pin 07 and P3 pin 05.
8. Disconnect P2 pin 07 by cutting wire on the solder side near the pin.
9. Check no-connection between P2 pin 07 and P3 pin 05.
10. Connect P2 pin 07 to T2 pin 16 with insulated wire on the solder side.
11. Change PAL package P2 from CC30 to CC32.

If FCN 22 is made then:

12. Remove wire between P2 pin 07 and P1 pin 29.
13. Connect P2 pin 07 to T2 pin 16 with insulated wire on the solder side.
14. Change PAL package P2 from CC31 to CC32.
15. Change revision level to E by removing the letter D in the PCB identification on the component side of the board.

CIRCUITS INVOLVED:

Name	Type	Position
L7	74LS14	A 7,9.
T2	PAL CC11	B 5,4.

P4	74S04	B	5,5.
O2	PAL CC40	A	9,7.
I5	74ALS574	A	7,7.
M3	74LS11	B	8,2.
M4	74LS74	B	10,1.
P2	PAL CC30	B	4,5.
P3	74ALS74	B	7,4.
P1	8085	B	2,4.

SUPERMAX FIELD CHANGE NOTICE NO. 26

DATE: 850829

MODULE: CIOC MODULE 0900

CATEGORY:

PRODUCTION CHANGE.

IN THE FIELD: TO BE MADE WITHOUT ANY UNNECESSARY DELAY.

CORRECTS THE ERROR:

System hang up because of an illegal bus interrupt.

NEEDED TOOLS:

Hand tools. PAL CC11.

DESCRIPTION:

1. Update board to revision level D. (Field change note 22)
2. Check with ohm-meter the connection between A2 pin 11 and M9 pin 08.
3. Disconnect A2 pin 11 by cutting wire on component side. See page 3.
4. Check no-connection between A2 pin 11 and M9 pin 08.
5. Check with ohm-meter the connection between A3 pin 04 and F2 pin 01.
6. Disconnect A3 pin 04 by cutting wire on component side. See page 4.
7. Check no-connection between A3 pin 04 and F2 pin 01.
8. Check with ohm-meter the connection between A3 pin 02 and A4 pin 01.
9. Disconnect A3 pin 02 by cutting wire on solder side. See page 5.
10. Check no-connection between A3 pin 02 and A4 pin 01.

11. Check with ohm-meter the connection between A3 pin 02 and the plated through hole near the pin on the solder side. See page 5.
12. Disconnect A3 pin 02 by cutting wire on solder side. See page 5.
13. Check no-connection between A3 pin 02 and the plated through hole near the pin.
14. Connect A2 pin 11 to F2 pin 01 with insulated wire on the component side.
15. Connect A3 pin 02 to 02 pin 15 with insulated wire on the component side.
16. Connect A3 pin 04 to 01 pin 13 with insulated wire on the component side.
17. Connect A4 pin 01 to the plated through hole near A3 pin 02 with insulated wire on the solder side.
18. Change PAL package T2 from CC10 to CC11.
19. Change revision level from D to E by removing the letter D in the PCB identification on the component side of the board.

CIRCUITS INVOLVED:

Name	Type	Position
A2	74LS05	A 6,5.
A3	74LS03	B 2,10.
A4	74LS257	B 1,10.
F2	74ALS573	A 7,3.
01	PAL CC70	A 8,7.
02	PAL CC40	A 9,7.
M9	74LS00	B 6,1.
T2	PAL CC10	B 5,4.

Component side:



Component side:

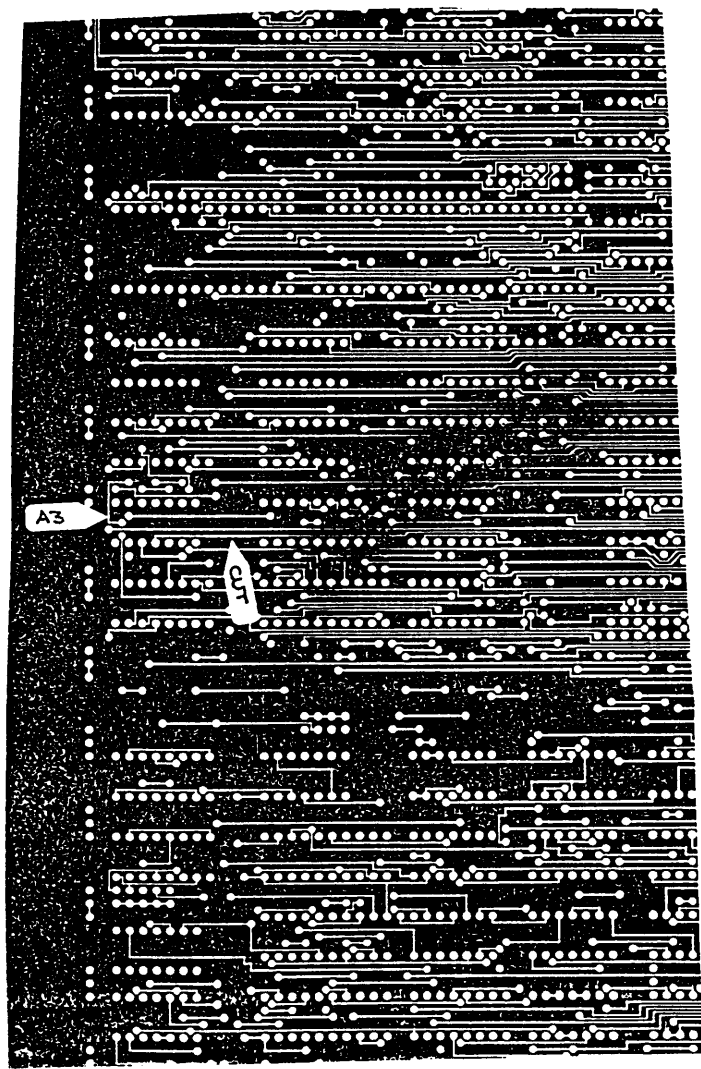

Solder side:

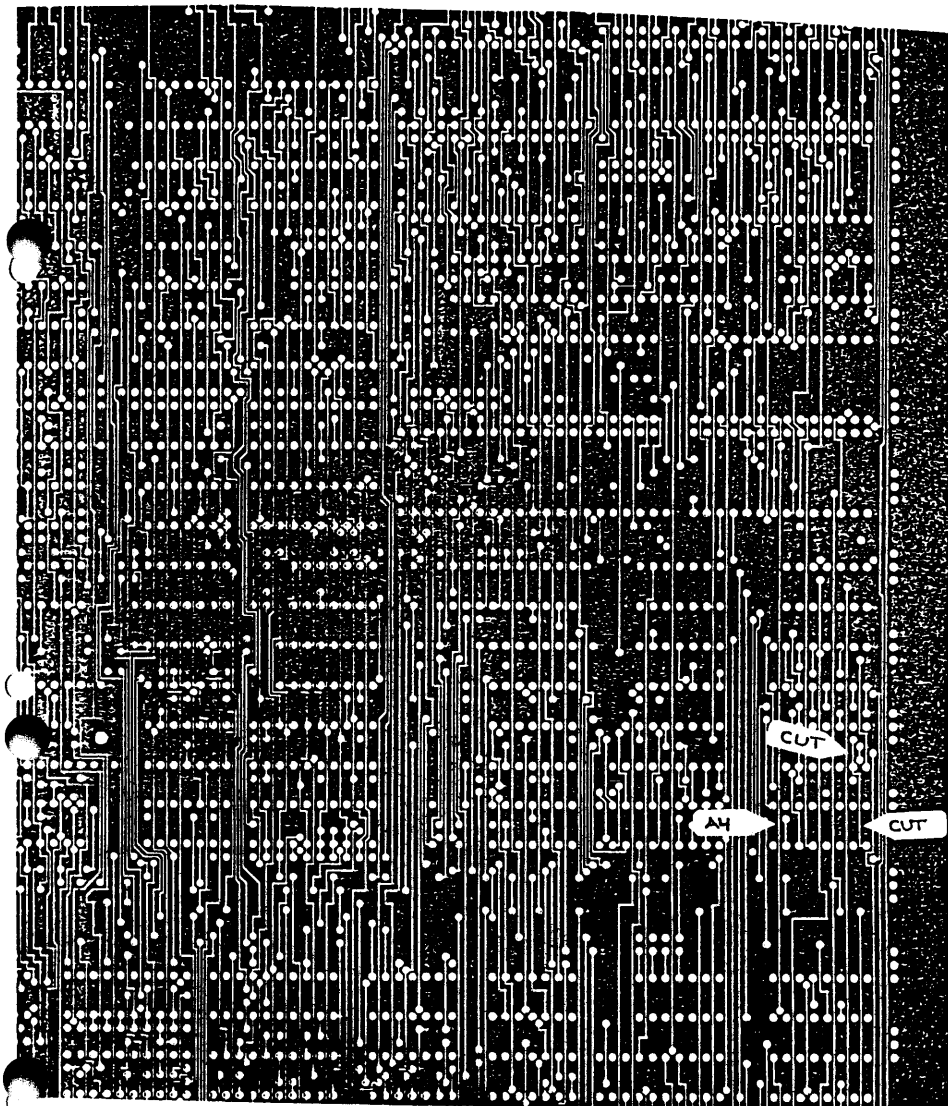

SUPERMAX FIELD CHANGE NOTICE NO. 22

DATE: 850814

MODULE: CIOC MODULE 0900

CATEGORY:

PRODUCTION CHANGE.

IN THE FIELD:
TO BE MADE AT A SUITABLE OCCASION.

CORRECTS THE ERROR:

Bug in the arbitration between internal and external memory cycles. The bug is only visible, when the module runs the SUPERMAX diagnostic program "bustest".

NEEDED TOOLS:

HAND TOOLS. PAL CC31. Insulated wire.

DESCRIPTION:

Package P1 is LSI 8085, Position B 2,5

Package P2 is PAL CC30, Position B 4,5

Disconnect P2 pin 07 by cutting the wire on the solder side close to the pin.

Connect P2-07 to P1-29 with insulated wire on the solder side of the board.

PAL package P2 is changed from CC30 to CC31.

Change revision level from C to D by removing the letter C in the PCB identification on the component side of the board.

SUPERMAX FIELD CHANGE NOTICE NO. 13

DATE: 841121.

MODULE: 0900B CIOC MODULE

CATEGORY:

To be made without any delay at all.

CORRECTS THE ERROR:

Proper function of communication channel 0 when using the RS-422 interface.

NEEDED TOOLS:

Hand tools. Insulated wire.

DESCRIPTION:

1. Disconnect insulated wire between Q8-13 and T5-15 on solder side.
2. Connect Q8-13 to V7-06 with insulated wire on solder side.
3. Remove jumper between SK3-04 and SK4-04.
4. Place jumper between SK3-03 and SK4-03.
5. Update revision level for the PCB from 0900B to 0900C by removing the letter B on the component side.

CIRCUITS INVOLVED:

NAME	TYPE	POSITION
Q8	74LS08	B 3,8
T5	PAL CC170	B 6,7
V7	74LS273	B 7,7
SK3, SK4	STRAP	A 7,11

SUPERMAX FIELD CHANGE NOTICE NO. 12

DATE: 841025.

MODULE: 0900A CIOC MODULE

CATEGORY:

To be made at a suitable occasion.

CORRECTS THE ERROR:

Not possible to use DMA transfers to/from the USARTs.

Proper function of the test programs.

NEEDED TOOLS:

Hand tools. Insulated wire.

DESCRIPTION:

1. Disconnect W1-11 by cutting wire on component side close to the pin.
See page 2.
2. Disconnect W1-09 by cutting wire on solder side close to the pin.
See page 3.
3. Connect W1-11 to W4-14.
4. Connect W1-09 to W4-15.
6. Update revision level for the PCB from 0900A to 0900B by removing the letter A on the component side.

CIRCUITS INVOLVED:

NAME	TYPE	POSITION
W1	PAL CC130	B 10,7
W4	8251	B 10,8

Component side:



Solder side:

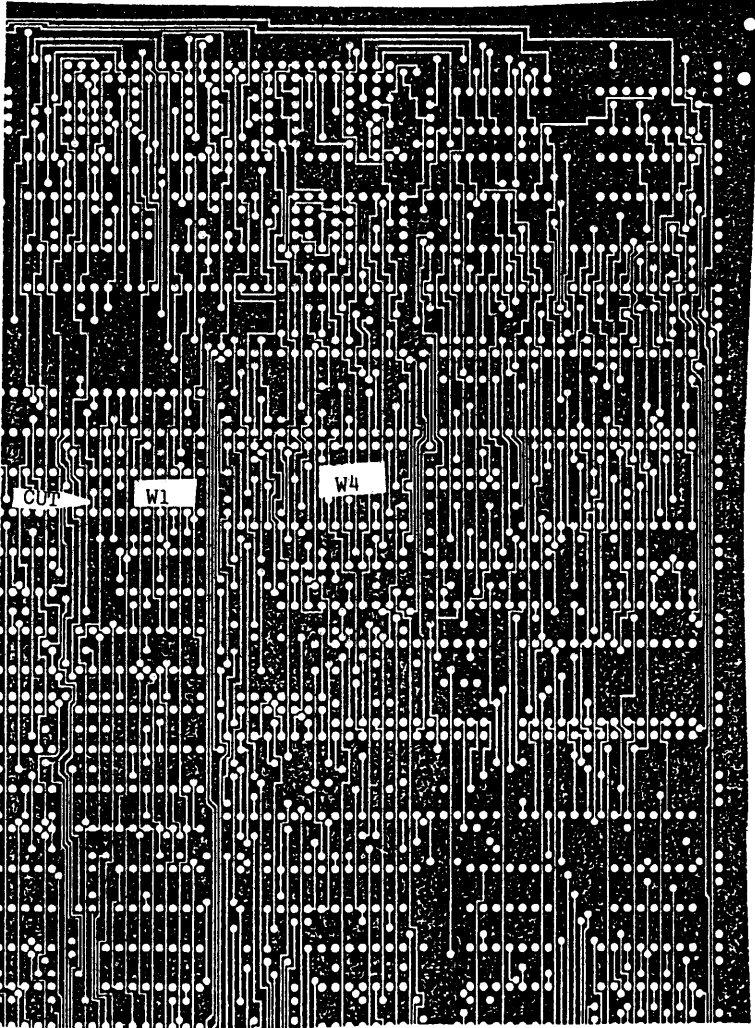

Status

Rev. 01.11.96

Supermax Field Change Notes : 1-162
Supermax Miscellaneous FCN : 1-39
Supermax TPP Field Change Notes : 1-85

Supermax Cards:

Name	No.	Assy	PCB	Last FCN	Date
CIOC	0900	D	F	76	890116
CIOC	0901	D	B	76	890116
DIOC1	0400	A	H	75	890116
DIOC1	0401	A	H	75	890116
DIOC1	0402	A	G	75	890116
DIOC2	1100	F	G	85	890627
DIOC2	1101	E	B	85	890627
DIOC3-1	4000-1	F	K	142	940624
DIOC3-2	4000-2	A	G	142	940624
DIOC3-3	4000-3	A	A	142	940624
HDLC-1	4640	B	C	117	931202
HDLC-2	4640	B	C	117	931202
HDLC-3	4640	B	B	117	931202
ISDN	30	A		151	950919
MCU	0100	F	C	71	890116
MCU	0101	B	C	71	890116
MCU	3400	F	D	72	890116
MCU	4100	J	C	106	920126
MCU	4101	J	C	106	920126
MCU	4501-1	A	D	122	930201
MCU	4501-2	A	C	122	930201
MCU	4700			153	950919
MIOC	4600	D	B	134	930715
MIOC	4800	-	C	148	950814

Name	No.	Assy	PCB	Last FCN	Date
NIOC	1600	E	F	99	910308
NIOC	3600	D	E	99	910308
SIOC	0300	?	?	74	890116
SIOC	0301	?	?	74	890116
SIOC	0301-1	?	?	74	890116
SIOC2	3600	D	E	99	910308

Memory Modules:

Name	No.	Assy	PCB	Last FCN	Date
RAM	0200	A	A		
RAM	1400	A	A		
RAM	3000	A	A		
RAM	3100	A	A		
RAM	3200	A	A		
RAM	3300	A	A		
RAM	4400	A	A		

Supermax Cabinet:

Name	No.	Assy	PCB	Last FCN	Date
Service Computer	4250	D	B	132	930801
Service Computer back panel	4260	B	B	131	930801
Power Supply	EMSP-610 B			115	930201

SGD:

Name	No.	Assy	PCB	Last FCN	Date
ALPHA	2500	A	D	37	910118
ALPHA	2510	C	B	38	910110
GRAP.	2600	D	D	39	910110
TABLET	-	-	B	14	880113

Ethernet equipment:

Name	No.	Assy	PCB	Last FCN	Date
NTC	1300	?	?	34	900813
NTC2	1310	E	B	120	930104
TERM32-box	4680	B	A	113	920821

Enterprise/SPC3 modules:

Name	No.	Assy	PCB	Last FCN	Date
BAIO	301			158	960125
BAIO	302			158	960125
BPL	304			150	950825
CPU	300/301			149	951120
MEM	301			147	950424
MMD	301/302		B	145	950315
PMD	301		A	152	950919
PMD	303		A	161	960708
PMD	304		A	161	960708
SCU	302			160	960416
TPS	301		A	162	961011

Supermax Field Change Notice no. 159

Module:	Seagate ST32550N, 2.4 GB winchester.
Date:	96.04.15

Category:

- Production change.
- In the field: If errors occur.

Corrects the error:

The disk may occasionally fail to release the bus after an error condition, i.e. the SCSI bus may hang.

This has been seen only with a disk firmware revision ASA2 0011, thus disks with this firmware must be upgraded to the latest version, which is now revision 0021.

Additional information:

On the ST32550 disk the firmware is not in an EPROM, but is downloaded to a flash EEPROM in the drive. At present the Diagnostic Program is not able to download a file to the flash EEPROM in the drive, so the drive must be sent to the Repair Center for upgrading.

Needed tools:

Hand tools.

Description:

- On the Supermax Multiserver: Using the command "J - Read parameters from winchester" in the Supermax Diagnostic Program, check the current revision level of the drive. If the revision is less than 0016, the firmware must be upgraded to revision level 0021.
- On the Supermax Enterprise Server: Using the "sdconf" command from the SMES Diagnostic Program, check the current revision level of the drive. If the revision is less than 0016, the firmware must be upgraded to revision level 0021.

Previous FCN:

None.

Supermax Field Change Notice no. 144

Module:	Micropolis 2105-08, 600 MB winchester. FCN no 2.
Date:	94.09.02

Category:

- Production change.
- In the field: If errors occur.

Corrects the error:

The disk may occasionally give a read data error, or the disk may fail during/after a format command, or when used in a mirrored configuration, it may give a verify error after backup (data may be transferred from a wrong address in case ECC has been used).

This has been traced to a firmware code error and the firmware must be upgraded to the latest version, which is now revision 4976.

This FCN replaces the previous FCN141.

Additional information:

- On the 2105 disk the firmware is not in an EPROM, but is downloaded to a flash EEPROM in the drive. At present the Diagnostic Program is not able to download a file to the flash EEPROM in the drive, so the drive must be sent to the Repair Center for upgrading.

Needed tools:

Hand tools.

Description:

Using the command "J - Read parameters from winchester" in the Diagnostic Program, check the current revision level of the drive. If the revision is less than 4976, the firmware must be upgraded to level 4976.

The disk must be shipped to the Repair Center to be upgraded.

PS.: Some 2105 drives may return "2112-08" instead of "2105-08" on an Inquiry command. This is not an error, but a firmware feature.

The 2105 disk is essentially a 2112 disk. The main difference is that the 2105 has eight data surfaces, and the 2112 has 15 data surfaces, so the 1.2 GB 2112 returns "2112-15" on the Inquiry command.

Supermax Field Change Notice no. 143

Module: Micropolis 2112-15, 1.2 GB winchester. FCN no 2.

Date: 94.09.02

Category:

- Production change.
- In the field: If errors occur.

Corrects the error:

The disk may occasionally give a read data error, or the disk may fail during/after a format command, or when used in a mirrored configuration, it may give a verify error after backup (data may be transferred from a wrong address in case ECC has been used).

This has been traced to a firmware code error and the firmware must be upgraded to the latest version, which is now revision 4976.

This FCN replaces the previous FCN140.

Additional information:

- On the 2112 disk the firmware is not in an EPROM, but is downloaded to a flash EEPROM in the drive. At present the Diagnostic Program is not able to download a file to the flash EEPROM in the drive, so the drive must be sent to the Repair Center for upgrading.

Needed tools:

Hand tools.

Description:

Using the command "J - Read parameters from winchester" in the Diagnostic Program, check the current revision level of the drive. If the revision is less than 4976, the firmware must be upgraded to level 4976.

The disk must be shipped to the Repair Center to be upgraded.

Supermax Field Change Notice no. 141

Module:	Micropolis 2105-08, 600 MB winchester. FCN no 1.
Date:	94.04.22

Category:

- Production change.
- In the field: If errors occur.

Corrects the error:

The disk may occasionally give a read data error, or the disk may fail during/after a format command.

This has been traced to a firmware code error and the firmware must be upgraded to the latest version, which is revision 4973.

On the 2105 disk the firmware is not in an EPROM, but is downloaded to a flash EEPROM in the drive. At present the Diagnostic Program is not able to download a file to the flash EEPROM in the drive, so the drive must be sent to the Repair Center for upgrading.

Needed tools:

Hand tools.

Description:

Using the command "J - Read parameters from winchester" in the Diagnostic Program, check the current revision level of the drive. If the revision is less than 4973, the firmware must be upgraded to level 4973.

The disk must be shipped to the Repair Center to be upgraded.

PS.: Some 2105 drives may return "2112-08" instead of "2105-08" on an Inquiry command. This is not an error, but a firmware feature.

The 2105 disk is essentially a 2112 disk. The main difference is that the 2105 has eight data surfaces, and the 2112 has 15 data surfaces, so the 1.2 GB 2112 returns "2112-15" on the Inquiry command.

Supermax Field Change Notice no. 140

Module:	Micropolis 2112-15, 1.2 GB winchester. FCN no 1.
Date:	94.04.22

Category:

- Production change.
- In the field: If errors occur.

Corrects the error:

The disk may occasionally give a read data error, or the disk may fail during/after a format command.

This has been traced to a firmware code error and the firmware must be upgraded to the latest version, which is revision 4973.

On the 2112 disk the firmware is not in an EPROM, but is downloaded to a flash EEPROM in the drive. At present the Diagnostic Program is not able to download a file to the flash EEPROM in the drive, so the drive must be sent to the Repair Center for upgrading.

Needed tools:

Hand tools.

Description:

Using the command "J - Read parameters from winchester" in the Diagnostic Program, check the current revision level of the drive. If the revision is less than 4973, the firmware must be upgraded to level 4973.

The disk must be shipped to the Repair Center to be upgraded.

Supermax Field Change Notice no. 138

Module: Supermax 6. FCN no 2.

Date: 94-03-24

Category:

- Production change.
- In the field, in case of error or at a suitable occasion.
- Only 6 pieces of Supermax 6 with this error are located in the field. They can be identified by the following serial numbers:
930084, 12736, 930093, 932217, 930266, and 932215.

Corrects the error:

The primary EARTH and secondary GND (0V) of the power supply should be tied together. If not, noise is generated, that affects the writing ability of the streaming tape drive. This error has been observed using the Diagnostic Programs.

Needed tools:

Hand tools.

Supermax FCN kit 138, stock number 95101380, consisting of:

1. Appx. 20cm of wire with a ring tongue terminal at one end and an AMP standard timer contact at the other end.

Description:

1. Insert the "AMP standard timer contact" end of the wire in connector 1A4 pin 4 and attach the other end below a screw to the left of the connector.
2. Update the revision level by removing the letter B from the label on the rear of the cabinet.

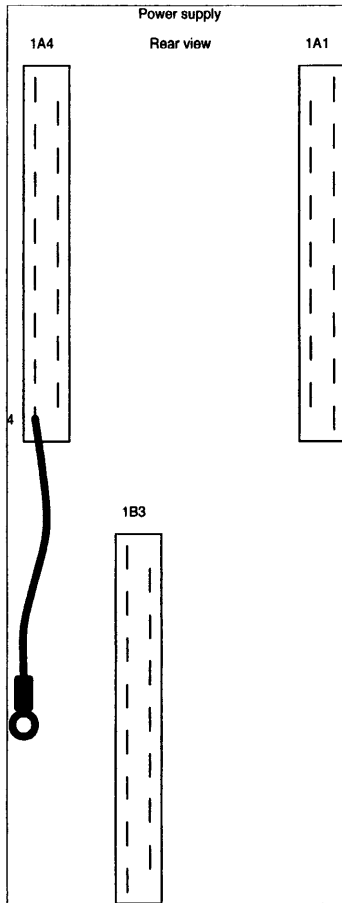

Supermax 6. Power supply.

Supermax Field Change Notice no. 137

Module:	Micropolis 1684-7, 380 MB half-height winchester. FCN no 1.
Date:	93.10.20

Category:

- Production change.
- In the field: If errors occur.

Corrects the error:

The disk may occasionally show a 1 bit data read error. The error is not reported by the disk itself, but data seem to have changed on subsequent reads. When used in a mirrored configuration, this may result in a verify error after backup.

The error is similar to the error on the Micropolis 1588 disk (fcn135), but the 1684-7 disks have been screened for this error by the manufacturer and hence this error for the 1684 disk is expected to be much less frequent than for the 1588 disk in the field. However, the screening has not been 100% effective, and there may be a few disks in the field showing this error.

In case the error can be positively identified as a disk related read error and there's no corresponding entry in the errorlog, the corrective action mentioned below should be initiated.

When a failing disk has been identified as suffering from this error, the disk controller board should be replaced with a board that has been reworked by the manufacturer. The new board will have firmware revision ASOD.

Additional information:

- It is characteristic for this error that it is NOT reported by the drive itself, so in case there's a message in the errorlog, the disk problem is not caused by the above mentioned error.
- The replacement boards will be shipped from the manufacturer carrying a special label indicating that they have been screened for this error. They come with an additional label that must be placed on the disk drive frame (on the metal frame on the end where the SCSI connector is located) to clearly indicate that the drive has been serviced.

Needed tools:

Hand tools.

Supermax FCN kit 137, stock number 95101370, consisting of:

1. One replacement PCB for the 1684 disk.
2. One label.

Description:

Detach the PCB from the HDA. Replace the PCB with the new board and reassemble the disk drive. Place the additional label on the disk frame on the side with the 50 pin SCSI connector. All information regarding the formatting is stored on the HDA, so the new PCB will read this information and retrieve the data information accordingly. Thus the reassembled disk drive should not be reformatted before installation. The original data information will be preserved. Only in case of accidents during the PCB replacement it will be necessary to read in a data backup.

Supermax Field Change Notice no. 135

Module:	Micropolis 1588-15, 760 MB full-height winchester. FCN no 2.
Date:	93.07.21

Category:

- Production change.
- In the field: If errors occur.

Corrects the error:

As mentioned in FCN125, the disk may occasionally show a 1 bit data error, especially when operating in a low temperature environment (below 20C). The error is not reported by the disk itself, but data seem to have been changed on subsequent reads. When used in a mirrored configuration, this may result in a verify error after backup.

This error is unfortunately not limited to the serial number range indicated in FCN125, but may occur on all disks using a specific combination of NMOS DRAM's and Emulex controller. As a consequence the printed circuit board on ALL drives must be replaced with boards that have been tested by the manufacturer. The new boards will have firmware revision ASOD.

Additional information:

- These replacement boards will be shipped from the manufacturer carrying a special label indicating that they have been screened for this error. They come with an additional label that must be placed on the disk drive frame (on the metal frame on the end where the SCSI connector is located) to clearly indicate that the drive has been serviced.

Needed tools:

Hand tools.

Supermax FCN kit 135, stock number 95101350, consisting of:

1. One replacement PCB for the 1588 disk.
2. One label.

Description:

Detach the PCB from the HDA. Replace the PCB with the new board and reassemble the disk drive. Place the additional label on the disk frame on the side with the 50 pin SCSI connector. All information regarding the formatting is stored

on the HDA, so the new PCB will read this information and retrieve the data information accordingly. Thus the reassembled disk drive should not be reformatted before installation. The original data information will be preserved. Only in case of accidents during the PCB replacement it will be necessary to read in a data backup.

Supermax Field Change Notice no. 132

Module:	SCU4250, Service Computer, PCB 4250 ISS 2. FCN no 5.
Date:	93-06-08

Category:

- Production change.
- In the field, if error occurs.

Corrects the error:

The error is seen as a parity error (error code 0xF6) in the error log. The reason for this FCN is because of unavailability of DRAM's in the correct speed version.

Needed tools:

Hand tools.

Supermax FCN kit 132, stock number 95101320, consisting of:

- One crystal oscillator 33.3333 MHz.

Description:

- Replace OSC1 (40MHz) with the new oscillator (33.3333MHz).
- Update the ASSY revision field from C to D by removing the letter C.

Circuits involved:

Name	Type	Position
OSC1	Oscillator	A11

Supermax Field Change Notice no. 131

Module:	SCB4260 Service Computer Back Panel, PCB4260 Iss. 0 and 1. FCN no 2.
Date:	93-06-08

Category:

- Production change.
- In the field, if error occurs or when installing Micropolis disks of type 2112.

Corrects the error:

The fan control circuitry generates noise on the +12V supply voltage. This noise affects the power fail detection circuitry on the disks, resulting in various errors. The problem has only been seen on Micropolis 2112 disks, but could cause problems on other disks also.

Needed tools:

Hand tools.

Supermax FCN kit 131, stock number 95101310, consisting of:

1. Two ceramic capacitors 1 μ F 63V stock no. 99020843.

Description:

- Add the two capacitors on the solder side of the PCB, at the positions indicated on the drawing.
- Update the ASSY revision field from A to B by removing the letter A.

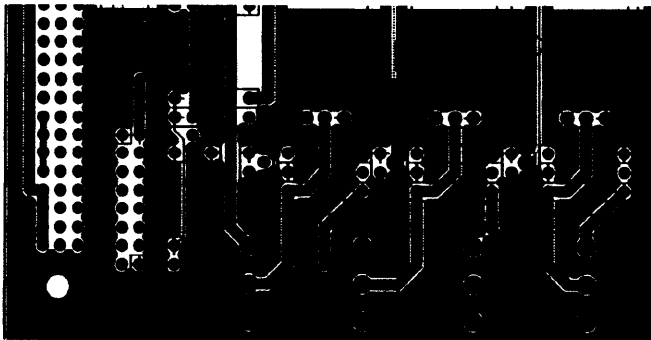

SCB4260 Board layout. Solder side

Supermax Field Change Notice no. 130

Module:	Micropolis 2112S, 1.2 GB 3.5" winchester. FCN no 1.
Date:	93.05.19

Category:

- Production change.
- In the field: If errors occur.

Corrects the error:

To enable the production to use second source disks it is required to change the configured physical disk size of the Micropolis disk from 1024 MB to 1000 MB. This even allow disks (of size 1000 MB) from different manufacturers to be used in case of errors as replacements for Micropolis disks in disk arrays. This avoids the need for keeping inventory of more than one type of disk for each disk size at the service centers.

This involves reconfiguring the disks in existing installations. However, it is not necessary to reformat the disks.

Additional information:

- It is recommended to check the configuration of all installed 1.2 GB disks (Micropolis type 2112S) according to the description above. This should be done to avoid any potential data loss in the event that a failing disk may have to be replaced by a second source disk.

Needed tools:

Hand tools.
Supermax Diagnostic Programs version, 5.1.3.

Description:

The physical disk size entry on the disk must be changed from 0x40000000 to 0x3E800000 (i.e. from 1024 to 1000 MB) using the Supermax Diagnostic Program. Use the "Set-up of disk system" command (W) and the "Change physical disk size" sub-command (C).

For disk systems it is also necessary to reconfigure the subsystem setup and change the disk size from 2047 to 2000 MB on each subsystem. This requires all data to be backed up and read back after the reconfiguration. The hardware configuration should then be updated (using chlds) according to this change.

Supermax Field Change Notice no. 129

Module:	Supermax 4, 6, 12 and 24. FCN no 1.
Date:	93-05-14

Category:

- Production change.
- In the field, if installing more than one Supermax on a UPS or at a suitable occasion.

Corrects the error:

The second Supermax will detect a power fail situation, when the first Supermax is turned off.

The Service Computer does not correctly control the voltages of the power supply (SM6, SM12 and SM24 only).

Needed tools:

Hand tools.

Supermax FCN kit 129, stock number 95101290, consisting of:

1. One diode 1N5818RL.
2. 4 cm of flexible insulation.
3. One label, stock number 99080162.

Description:

1. Insert the diode in the blue wire on the POWER FAIL INPUT connector. See the drawing for orientation details. Remember to install the flexible insulation on the wire. Seal the component by heating the flexible insulation.
2. Cut the brown wire in the cable connecting the SCB4260 Service computer backplane plug JPS1 (JPS2) and the power supply connector 1A1 pin z32 REMOTE MARG.
3. Place the label on the rear panel, next to the label containing the model/type information. Update to revision B by removing the letter A from the label.

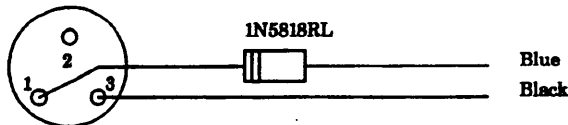

Power Fail plug
Rear view

Supermax Field Change Notice no. 128

Module:	SCU4250, Service Computer, PCB 4250 ISS 2. FCN no 4.
Date:	93-02-03

Category:

- Production change.
- In the field, if error occurs or at a suitable occasion.

Corrects the error:

The error is seen as a parity error (error code 0xF6) in the error log.

Needed tools:

Hand tools.

Supermax FCN kit 128, stock number 95101280, consisting of:

- Two resistors 1 kohm.

Description:

- Connect one resistor between IC10 pin 4 and IC10 pin 14 by placing the resistor across the component.
- Connect one resistor between IC12 pin 4 and IC12 pin 14 by placing the resistor across the component.
- Update the ASSY revision field from B to C by removing the letter B.

Circuits involved:

Name	Type	Position
IC10	74LS280	B8
IC12	74LS280	A10

Supermax Field Change Notice no. 125

Module:	Micropolis 1588-15, 760 MB full-height winchester. FCN no 1.
Date:	93.01.22

Category:

- Production change.
- In the field: If errors occur.

Corrects the error:

The disk may occasionally show a 1 bit data error, especially when operating in a low temperature environment (below 20C). The error is not reported by the disk itself, but data seem to have been changed on subsequent reads. When used in a mirrored configuration, this may result in a verify error after backup.

This error is caused by a faulty IC chip on the disk. The disk must be replaced and sent to the repair center. The error may be present on disks within a certain range of serial numbers.

Additional information:

- It is recommended to check the serial numbers of all installed 760 MB disks (Micropolis type 1588-15) according to the description below even if they have not yet shown any errors. This should be done to avoid any potential data losses.

Needed tools:

Hand tools.

Description:

Check the serial number of the disk drive. The serial number is a 10 digit number. If the first three digits in the serial number are one of the combinations 112, 201, 202, or 203, then the disk must be replaced.

Supermax Field Change Notice no. 124

Module:	Exabyte EXB 8200, 2 GB Video streamer. FCN no 1.
Date:	93.01.22

Category:

- Production change.
- In the field: If errors occur.

Corrects the error:

The streamer may sometimes report an error 04 (hardware error) in the system errorlog. In this case the streamer should be updated according to this FCN (firmware change). There may be other causes to an 04 error, though.

Additional information:

- The diagnostic program will tell you, which firmware version your drive has. Current version is 4\$25. New version is 2618.

Needed tools:

Hand tools.

Supermax FCN kit 1xx, stock number 95101xx0, consisting of:

1. One EPROM labeled "MXPROM-2618 013000-006"
2. One EPROM labeled "SVPROM-C034 013087-030"

Description:

- Replace MXPROM and SVPROM EPROM devices with EPROMs in FCN kit.

It is recommended to send the drive to the repair center for update, as replacing the EPROMs involves the disassembly of the drive and as the drive should be tested after reassembly.

Supermax Field Change Notice no. 121

Module:	Service Computer, 4250 Iss 2 - FCN no 3.
Date:	93-01-04

Category:

- Production change.
- In the field: To be made if error occurs or when the Supermax platform, The Optimized RISC Platform, is installed.

Corrects the error:

- Known errors are corrected and new features are added in the EPROM firmware.

Errors corrected:

- When the Service Computer is connected to the service port *tty command* and text is sent to the terminal, some times the last character is missing. The character will be displayed when a new text is sent to the terminal.
- When the Service Computer is powered-up, the Service Computer will occasionally generate a panic error in the log file, but no panic error has occurred.
- When loading the Service Computer software from the floppy and an error occurs, the Service Computer will write a wrong error message in the log file.
- Because of a missing strap on some Service Computer boards, the Service Computer will not detect if the diskette is changed.

New features added:

- The Service Computer is now able to send/receive error logs and crash logs to/from the Supermax modules. This means that error logs on the Supermax are stored in the Service Computer log files, and vice versa.
- The size of a log file message is changed from max. 16 characters to 256 characters.
- The number of log entries in a log file is changed from 200 to 1500. (One entry is 16 characters)
- A new Service Computer command *loop <-t seconds>* is implemented.

Needed tools:

Hand tools.

Supermax FCN kit 121, stock number 95101210, consisting of:

- One EPROM labeled "SCBOOT even Vers 1.1 17.07.1992"
- One EPROM labeled "SCBOOT odd Vers 1.1 17.07.1992"
- One strap

Description:

- Replace EPROM device EPROMH with EPROM labeled "SCBOOT even"
- Replace EPROM device EPROML with EPROM labeled "SCBOOT odd"
- Check ST6 strap on the Service Computer board. Must be mounted.

Circuits involved:

Name	Type	Position
EPROML	EPROM 27512	C10
EPROMH	EPROM 27512	C10
ST6	Strap	J5

Supermax Field Change Notice no. 118

Module:	Service Computer, 4250 Iss 2. FCN no. 2.
Date:	92-12-09

Category:

- Production change.
- In the field, if error occurs.

Corrects the error:

Hazardous timing of the read and write control signals.

Needed tools:

Hand tools.

Supermax FCN kit 118, stock number 95101180, consisting of:

1. One PAL "SC21".

Description:

- Change the PAL in PAL2 from SC20 to SC21.
- Update the ASSY revision field from A to B by removing the letter A.

Circuits involved:

Name	Type	Position
PAL2	PAL SC21	A8

Supermax Field Change Notice no. 116

Module:	Supermax Slimline Disk Cabinet. FCN no. 1
Date:	92-11-30

Category:

- If error occurs.

Corrects the error:

- Occasional error 03 (media error) from the Video Streamer in the old disk cabinet. The airflow may take in dust particles that may cause the video streamer to fail.
- The error is corrected by exchanging the mounting bracket for the streamer with a new version including a fan that will re-route the airflow.

Needed tools:

Hand tools.

Supermax FCN kit 116, stock number 95101160, consisting of:

- 1 Mounting Bracket assembly for Video Streamer.

Description:

- Replace the mounting bracket assembly for the video streamer in the disk cabinet. Connect the fan to the +12V supply.

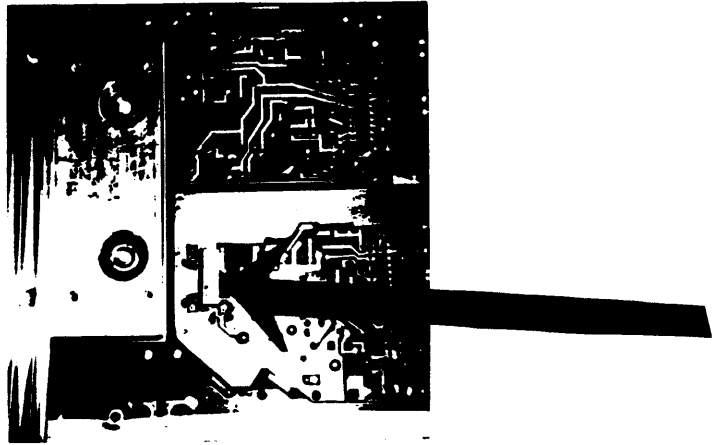

MODIFISERING EMSP-610

MOD B. 12/11-92 J.C.C.

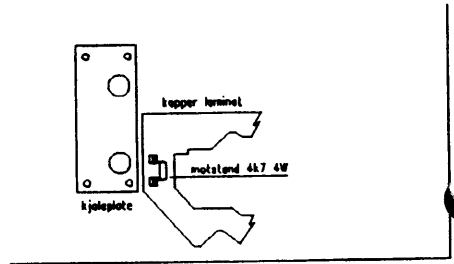
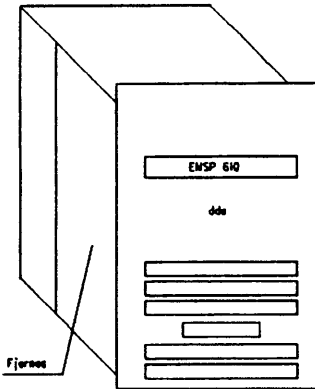

Figure 1.

Supermax Field Change Notice no. 115

Module: EMSP-610, where the revision field on the front plate is empty.
Power supply in Supermax 6, 12 and 24. FCN no 1.

Date: 92-11-19

Category:

- Production change.
- In the field, when error occurs.

The time needed to perform this FCN might exceed 30 minutes, so it is recommended to perform the FCN in the service center and not on location.

Corrects the error:

- The problem is voltage drops on the +12V output. The voltage drops occurs with only a small load on the +12V (appx. 1 or 2 disk drives). The error is seen as spurious reset of winchester disks and streamer drives.

Needed tools:

Hand tools.

Supermax FCN kit 115, stock number 95101150, consisting of:

1. One resistor Vitrohm 206-8, 4k7 4W.

Description:

1. Remove the front left heat sink by removing 12 screws.
2. Mount the resistor 4k7 4W in the two empty holes in the PCB. See figure 1 for mounting details.
3. Secure the resistor on the PCB by using some silicone glue.
4. Mount the heat sink again.
5. Update the revision field on the front plate of the power supply from "empty" to B by writing a B in the revision field.

Circuits involved:

See figure 1.

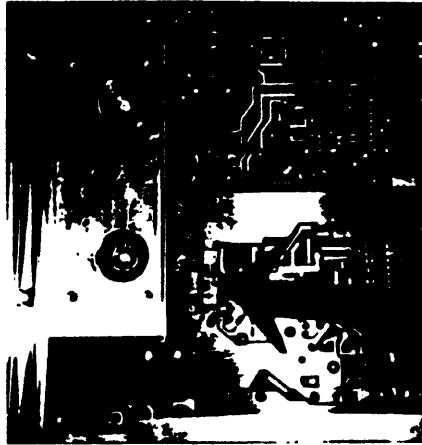

MODIFISERING EMSP-610

MOD B. 12/11-92 J.C.C.

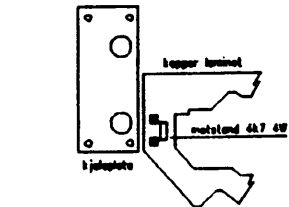
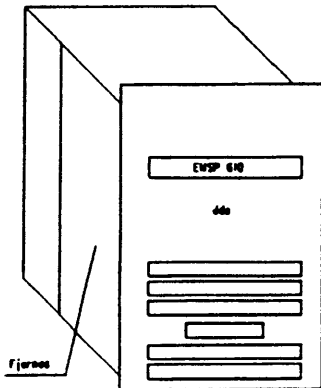

Figure 1.

Supermax Field Change Notice no. 112

Module: Supermax Rack model.

Date: 92-08-12

Category:

- If error occurs.

Corrects the error:

- Very seldom malfunction with different crash codes, or different error codes when using the Supermax Diagnostic bus test program.
- The error is corrected by using a new set of Bus extensions (flexprints).

Needed tools:

Hand tools.

Supermax FCN kit 112, stock number 95101120, consisting of:

- 3 Bus extensions Rack 3940 Issue 1.

Description:

- Replace the 3 Bus extensions with the new version.

Supermax Field Change Notice no. 109

Module: Micropolis 1528-15, 1.5 Gb full-height winchester.

Date: 92.04.14

Category:

- Production change.
- In the field: If errors occur or when formatting a disk.

Corrects the error:

1. When the disk is used as a boot disk, the boot procedure may in some cases not be carried through. This error is corrected with this FCN (firmware change).
2. The Read Ahead function may fail with the current version of the firmware. Therefore version 4.7 or earlier of the diagnostic program disables this function during formatting.

Version 5.0 or higher of the diagnostic program will enable the Read Ahead during formatting and a disk with the current firmware revision may then fail. Therefore it is necessary to upgrade the firmware using this FCN, before formatting the disk with the new diagnostic program.

Additional information:

- The diagnostic program will tell you, which firmware version your drive has. Current version is AS24. New version is AS25.
- This FCN may in some cases give you better performance, when the disk has been formatted with the new diagnostic program. This is because the Read Ahead function is now used.

Needed tools:

Hand tools.

Supermax FCN kit 109, stock number 95101090, consisting of:

1. One EPROM labeled "800524-06 AS25 CCEB"

Description:

- Replace EPROM device with PROM labeled "800524-06 AS25 CCEB" and format the disk using the Supermax Diagnostic Programs version 5.0 or higher.

Supermax Field Change Notice no. 111

Module: Supermax double Vertical model.

Date: 92-06-09

Category:

- If error occurs.

Corrects the error:

- Very seldom malfunction with different crash codes, or different error codes when using the Supermax Diagnostic bus test program.
- The error is corrected by using a new set of Bus extensions (flexprints).

Needed tools:

Hand tools.

Supermax FCN kit 111, stock number 95101110, consisting of:

- 3 Bus extensions Vertical 3950 Issue 1.

Description:

- Replace the 3 Bus extensions Vertical with the new version.

Supermax Field Change Notice no. 105

Module: Service Computer, 4250 Iss 2.

Date: 92-01-21

Category:

- Production change.
- In the field, when error occurs.

Corrects the error:

Hazardous timing of the memory control signals during a read-modify-write cycle and hazardous timing of the interrupt signals to the processor. The error is seen as panic error 0x88 or 0x8B.

Needed tools:

Hand tools.

Supermax FCN kit 105, stock number 95101050, consisting of:

1. One PAL SC12.
2. One PAL SC32.
3. One 74F74.
4. 20 cm insulated wire.

Description:

- Change the PAL in PAL1 from SC11 to SC12.
- Change the PAL in PAL3 from SC31 to SC32.
- Change IC08 from 74LS74 to 74F74.
- Disconnect IC17 pin 11 from the PCB by cutting the pin as close to the PCB as possible.
- Make a connection on the component side of the PCB, using the insulated wire, from IC17 pin 11 to IC02 pin 8.
- Update the PCB revision field from A to B by removing the letter A.

Circuits involved:

Name	Type	Position
PAL1	PAL SC11	A9
PAL3	PAL SC31	C8
IC08	74LS74	A8
IC02	74S74	A10
IC17	74ACT574	C5

Supermax Field Change Notice no. 104

Module:	Service Computer Back Panel, 4260 Iss. 0 and Iss 1.
Date:	92-01-20

Category:

- Production change.
- In the field, when installing a Supermax Disk cabinet on a Supermax 24, a Supermax 12 or a Supermax 6, which has been installed before 1991-12-01.

Corrects the error:

The Remote Power Off signal does not work correct, when a disk cabinet is installed.

Needed tools:

Hand tools.

Supermax FCN kit 104, stock number 95101040, consisting of:

1. One plug AMP 280370-2 stock no. 063160.
2. 20 cm insulated wire.

Description:

- Remove the 3M20 flat cable plug from JDIN.
- Cut the connection between JDIN pin 1 and J2 pin c14 and between JDIN pin 3 and J2 pin c15 on the component side of the PCB.
- Mount the AMP plug from the FCN kit in pin 1 and 3 of JDIN.
- Make a connection using the insulated wire between JDIN pin 1 and RE4 pin 13 and between JDIN pin 3 and RE4 pin 9.
- Move the cable in J4 on the Supermax motherboard to the plug in JDIN.
- Update the PCB revision field from A to B by removing the letter A.

Circuits involved:

JDIN, RE4 and the Remote Power Off cable to the Supermax I/O panel.

Supermax Field Change Notice no. 101

Module: Micropolis 1674, 170 Mbyte half-height winchester

Date: 91.04.05

Category:

- Production change.
- In the field: If 1674 is connected to DIOC3.

Corrects the error:

- Micropolis winchester 1674 has been delivered from the production with 3 different firmware versions. The 3 different firmware versions are AS09, AS0A and AS0C.
- The AS09 firmware has an error concerning the read ahead function. If a read command of 64 k bytes is issued on the SCSI bus, and the drive already holds the data in the cache buffer, the drive transfers wrong data on the SCSI-bus. The error only occurs when running the *dsback* program, and the winchester is connected to a DIOC3.
- The AS0A firmware has no error concerning the read ahead function.
- Use the Supermax Diagnostic Programs to determine the firmware version of the winchester.

Needed tools:

Hand tools.

Supermax FCN kit 101, stock number 95101010, consisting of:

1. One SMD PROM labeled "800365-11-6 AS0C BD29 10-24-89".

Description:

- Replace SMD PROM device with SMD PROM labeled "800365-11-6 AS0C BD29 10-24-89".

Supermax Field Change Notice no. 100

Module: Micropolis 1578, 380 Mbyte full-height winchester.

Date: 91.04.05

Category:

- Production change.
- In the field: If 1578 is connected to DIOC3.

Corrects the error:

- Micropolis winchester 1578 has been delivered from the production with 3 different firmware versions. The 3 different firmware versions are AS09, AS0A and AS0C.
- Some 1578 drives has another firmware version. (Different from AS09, AS0A or AS0C). In this case refer to Supermax Field Change Notice no. 82.
- The AS-09 firmware has an error concerning the read ahead function. If a read command of 64 k bytes is issued on the SCSI bus, and the drive already holds the data in the cache buffer, the drive transfers wrong data on the SCSI bus. The error only occurs when running the *dskback* program, and the winchester is connected to a DIOC3.
- The AS0A firmware has no error concerning the read ahead function.
- Use the Supermax Diagnostic Programs to determine the firmware version of the winchester.

Needed tools:

Hand tools.

Supermax FCN kit 100, stock number 95101000, consisting of:

1. One EPROM labeled "800365-11-6 AS0C BD29 10-24-89"

Description:

- Replace EPROM device with PROM labeled "800365-11-6 AS0C BD29 10-24-89".

SUPERMAX FIELD CHANGE NOTICE NO. 82

DATE: 890502

MODULE: MICROPOLIS 1578 380 MEGABYTE WINCHESTER.

CATEGORY:

Production change.

In the field: To be made without any unnecessary delay.

CORRECTS THE ERROR:

If there is more than one defect on one track, the defect management in some cases maps two different tracks to one track address.

The error is not seen using Supermax Diagnostic Programs. Running operating system the error results in corrupted file system, corrupted data, corrupted data base, ect.

Additional errors in rev. ASB2 and IC07 are:

ASB2 is unable to run on dioc module 4000.

IC07 causes the dioc module 4000 to panic with the following message on the serviceport: "PANIC, reset of SCSI occurred".

NEEDED TOOLS:

Hand tools.

PROM with firmware labeled AS09.

DESCRIPTION:

If the current firmware revision is labeled ASB2 or IC07: replace the winchester, and return the winchester to the repair center.

If the current firmware revision is labeled AS08:

Make a back up of the winchester.

Change the firmware in the controller to rev. AS09.

Reformat the winchester using diagnostic programs.

Restore the data.

If the current firmware is labeled with another version, other than the version mentioned above, the winchester is equipped with another type of interface board, and no action should be taken.

SUPERMAX FIELD CHANGE NOTICE NO. 50

DATE: 870930

MODULE: SUPERMAX SYSTEMS WITH 5.25" PRIAM WINCHESTER DRIVES
TYPE 717, 728 and 738

CATEGORY:

TO BE MADE AT A SUITABLE OCCASION.
TO BE MADE WHEN ERROR OCCURS.

CORRECTS THE ERROR:

Start up problems when the supermax is booted.
The error occurs only when power has been switched off.
The operating system may be unable to handshake with the
embedded SCSI controller on the drive, and is unable to
complete the boot procedure.

NEEDED TOOLS: Hand tools.

DESCRIPTION:

Remove strap W3 from the controller board on the winchester.

out: soft scsi bus reset.

SUPERMAX FIELD CHANGE NOTICE NO. 41

DATE: 870410

MODULE: ACB 4000 Winchester Disk Controller.

CATEGORY:

Production change.

In the field: To be made when error occurs.

CORRECTS THE ERROR:

Start up problems when the ACB 4000 controls winchester disk drives with track following servo.

After power up the ACB 4000 tries to read disk parameters from the disk drive. During these initial head movements the controller uses default values stored in the PROM for the disk parameters. If the default values do not conform with the disk drive, the controller cannot read the actual parameters and the controller will send the error message "blown format" to the host. Error code 1C.

The default values are marginal when the controller is used together with some disk drives with track following servo.

If the controller succeeds in reading the actual parameter from the disk, the disk drive will work without any problem.

If the controller cannot read the disk parameters, the host is unable to access the disk drive.

NEEDED TOOLS:

Hand tools.

PROM with firmware labeled ACB4000 rev.B.DDE

DESCRIPTION:

Change the firmware in the controller to rev.B.DDE.

Check the strapping of the controller in position J5.

Only one connection must be installed: J to I.

SUPERMAX FIELD CHANGE NOTICE NO. 40

DATE: 870318

MODULE: Supermax Compact with 8" floppy disk drive.

CATEGORY:

Production change.

In the field: To be made when error occurs.

CORRECTS THE ERROR:

Read errors on inner tracks. The read errors are caused by electromagnetic interference from the power supply. The interference propagates along the inner conducting surfaces of the Compact and is picked up by the read/write heads of the floppy disk drive. Depending upon the the quality of the diskette and the floppy disk drive the noise may cause read errors.

NEEDED TOOLS:

Hand tools.

Mounting kit.

DESCRIPTION:

Turn the floppy disk drive 180 degrees so the two light emitting diodes get close to the bottom of the Compact. By turning the disk drive the distance from the read/write heads to the surface of the Compact is increased and the pick up of noise reduced.

LED's

BEFORE CHANGE

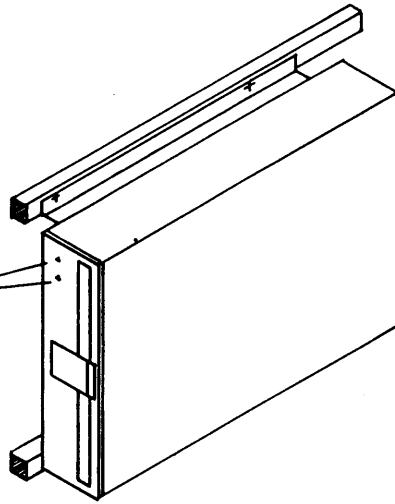

AFTER CHANGE

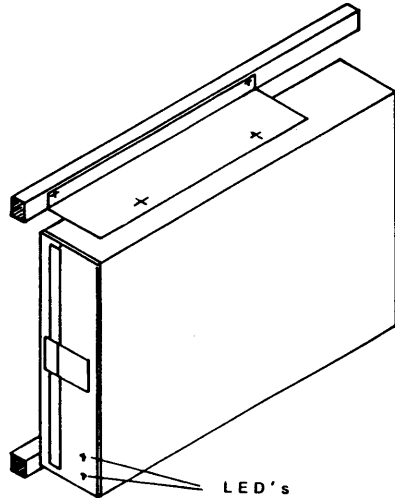

This document contains proprietary information and is not to be used or reproduced without the written permission of dansk data elektronik a/s



dansk data elektronik a/s,

Denmark, Copenhagen 199, Østergade 111, 2244 Rødovre, Denmark, Tel. 45 296 13 00

Issue	Date	Drawn	Approved	Scale	Tol.
1	070318	SCS			
				Material	
				Finish	

SUPERMAX FIELD CHANGE

NOTICE NO. 40

PCB no.		File no.	
Rev.			
Part no.	07020		40 A 052

SUPERMAX FIELD CHANGE NOTICE NO. 32

DATE: 860422

MODULE: SERVICE PORT AMPLIFIER 2300

CATEGORY:

PRODUCTION CHANGE.

IN THE FIELD: WHEN A REAL TIME CLOCK IS INSTALLED.

CORRECTS THE ERROR:

THE REAL TIME CLOCK MUST BE SUPPLIED WITH +/-12 VOLTS FROM THE SERVICE PORT.

NEEDED TOOLS:

HAND TOOLS.

DESCRIPTION:

MAKE TWO CONNECTIONS ON THE SOLDER SIDE OF THE SERVICE PORT AMPLIFIER USING INSULATED WIRE:

+ 12 VOLTS: CONNECT 3M20 PIN 16 TO DB25 PIN 21.

- 12 VOLTS: CONNECT 3M20 PIN 17 TO DB25 PIN 09.

UPDATE P.C.B. REVISION LEVEL FROM A TO B BY REMOVING THE LETTER A ON THE SOLDER SIDE OF THE BOARD.

SUPERMAX FIELD CHANGE NOTICE NO. 18

DATE: 850618

MODULE: SUPERMAX SYSTEMS WITH 5.25" WINCHESTER DISK DRIVES.

CATEGORY:

TO BE MADE AT A SUITABLE OCCASION.
TO BE MADE WHEN ERROR OCCURS.

CORRECTS THE ERROR:

A bug has been found in the firmware in Adaptec ACB 4000 hard disk controller. This controller controls 5.25" winchester disks in Supermax systems.

The bug is in the buffer management in the controller. Adaptec gives the following explanation:

"If the controller gets ahead of the host in data transfer and completely fills the buffer, an overflow occurs which is mis-handled."

The error has only been seen in two Supermax systems in the field as inexplicable disk errors.

NEEDED TOOLS: Hand tools.

DESCRIPTION:

The firmware is placed in a PROM on the ACB 4000 controller. The revision of the firmware is written on a label on the PROM.

Replace the PROM labeled 400510-00C with a new PROM containing firmware revision 400108-00A.

SUPERMAX FIELD CHANGE NOTICE NO. 11DATE: 840924 KANMODULE: SUPERMAX RACK MODEL. DISK CABINETCATEGORY:

TO BE MADE WHEN ERROR OCCURS.

CORRECTS THE ERROR:

If the disk cabinet contains a floppy disk drive type CDC 9406 and a winchester disk mounted to the right of the floppy disk drive, the winchester disk controller induces noise in the read amplifier on the floppy disk drive.

NEEDED TOOLS:

Hand tools. Update kit consisting of aluminum plate and 4 screws.

DESCRIPTION:

The aluminum plate is mounted on the floppy disk drive using screws 5-38 max 3/8"

SUPERMAX FIELD CHANGE NOTICE NO. 8

DATE: 840521 KAN

MODULE: All SUPERMAX modules except memory modules.

CATEGORY:

PRODUCTION CHANGE.

DESCRIPTION:

Two families of priority PALs have been used in SUPERMAX systems produced until now. One family has been used in systems with only one card cage, while the other family has been used in systems with two card cages.

To simplify production the family used in systems with two card cages will be used in all systems in the future.

The two families are NOT compatible. If the families are mixed in a system the system will fail in an unpredictable way.

LABELs on PRIORITY PALs

PRIORITY	NEW PALs	OLD PALs
00	P000	C160
01	P010	C161
02	P020	C162
03	P030	C163
04	P040	C164
10	P100	C165
11	P110	SP11
12	P120	SP12
13	P130	SP13
14	P140	SP14
20	P200	SP20
21	P210	SP21, DP21
22	P220	SP22, DP22
23	P230	DP23
24	P240	DP24
30	P300	DP30
31	P310	DP31
32	P320	DP32
33	P330	DP33
34	P340	DP34
40	P400	DP40
41	P410	DP41
42	P420	DP42
43	P430	DP43
44	P440	DP44

There is only one family of UNIT PALs but a new labeling is introduced:

LABELs on UNIT PALs

UNIT NUMBER	NEW LABEL	OLD LABEL
0	U000	C170
1	U010	C171
2	U020	C172
3	U030	C173
4	U040	C174
5	U050	C175, SU05
6	U060	SU06
7	U070	SU07
8	U080	SU08
9	U090	SU09, DU09
10	U100	SU10, DU10
11	U110	SU11, DU11
12	U120	DU12
13	U130	DU13
14	U140	DU14
15	U150	DU15

SUPERMAX FIELD CHANGE NOTICE NO. 2

DATE: 830808

MODULE: 0100B

CATEGORY:

TO BE MADE: NEVER

CORRECTS THE ERROR:

Corrects the numbering of FIELD CHANGE NOTICES

SECTION 2.0

NTC 1300 1

NTC2 1310 2

SGD 2500 3

SGD 2510 4

SGD 2600 5

SGD 6

7

8

OTHERS 9

SECTION 3.0 10

Miscellaneous Field Change Notice no. 34

Module:	Network Terminal Controller NTC
Date:	90.08.16

Category:

- Production change.
- In the field, in case of error.

Corrects the error:

- The NTC may disconnect all its LAN connections due to a voltage drop across the contacts of the power supply connector.

Needed tools:

- Hand tools.
- Crimp tool.
- One length of thick, isolated wire.

Supermax MFCN kit 034, stock number 95120340, consisting of:

1. Two crimp contacts for the power connector (female).

Description:

- Remove the contact for pin 5 (red wire) in the female part of the power supply connector.
- Crimp on a new contact to both the red wire and a new wire.
- Crimp on a contact to the other end of the new wire. Insert the two contacts into positions 5 and 6 in the connector (pin 2 on the male connector part is missing).
- In this way two pins are used for the +5 V power connection to the pcb.

MISCELLANEOUS FIELD CHANGE NOTICE NO. 32

DATE: 900301

MODULE: Network Terminal Controller NTC

CATEGORY: PRODUCTION CHANGE.

IN THE FIELD: TO BE MADE IN CASE OF ERROR

CORRECTS THE ERROR:

The NTC power supply (Astec model 9231) may fail after some time. This may cause the NTC to transmit almost continuously on the network.

The capacitor C9 in the power supply is located too close to the resistor R4 and will dry out because of the high temperature of R4. The capacitor must be relocated as described below.

NEEDED TOOLS:

Hand tools.
Solder iron.
One tie-wrap.
One capacitor 220 uF/40 V with long leads.

DESCRIPTION:

Remove capacitor C9.

A new capacitor 220 uF/40 V is tied to capacitor C7 with a tie-wrap. Then the capacitor leads are soldered to the C9 connections on the PCB.

MISCELLANEOUS FIELD CHANGE NOTICE NO. 26

DATE: 89.10.18

MODULE: Network Terminal Controller NTC.

CATEGORY:

PRODUCTION CHANGE.

IN THE FIELD TO BE MADE IN CASE OF ERROR.

CORRECTS THE ERROR:

The message "All connections in use." indicating that the NTC is unable to establish connections.

An established connection may occasionally block, when the NTC is heavily loaded.

NEEDED TOOLS:

HAND TOOLS, a set of CPU-1 version 4.05 EPROMS (2 pcs.).

DESCRIPTION:

Before updating the NTC, the Miscellaneous Field Change Note No. 19 must be made.

This will ensure that CPU-2 has version 4.0 firmware, as CPU-1 version 4.05 firmware will not operate with earlier versions of CPU-2 firmware.

MISCELLANEOUS FIELD CHANGE NOTICE NO. 24

DATE: 890329

MODULE: Network Terminal Controller NTC.

CATEGORY: PRODUCTION CHANGE.

IN THE FIELD: TO BE MADE IN CASE OF ERROR.

CORRECTS THE ERROR:

Delayed transfer of data from NTC to NIOC, when there is no transfer of data in the opposite direction. Using a terminal, the error occurs occasionally as delayed responses from the Supermax computer.

Ethernet controller receive hangup, when using the 8023A manchester encoder chip. A NTC might not receive connection requests if it has no established connections for a period of time. The error may occur for a NTC with printers, where the printers are used by establishing data controlled connections from Supermax computers.

An established connection to a Supermax Graphics Display may occasionally disconnect, when data is transferred from the NTC to the SGD and the flow of data is controlled by using the SGD Hold key.

NEEDED TOOLS: HAND TOOLS, a set of CPU-1 version 4.03 EPROMS (2 pcs.).

DESCRIPTION:

Before updating the NTC, the Miscellaneous Field Change Note No. 19 must be made.

This will ensure that CPU-2 has version 4.0 firmware, as CPU-1 version 4.03 firmware will not operate with earlier versions of CPU-2 firmware.

MISCELLANEOUS FIELD CHANGE NOTICE NO. 19

DATE: 880901

MODULE: Network Terminal Controller NTC.

CATEGORY: PRODUCTION CHANGE

IN THE FIELD: TO BE MADE AT A SUITABLE OCCASION
NOT LATER THAN 01.01.1989.

CORRECTS THE ERROR:

The new firmware (a set of EPROM's) version 4.0 corrects all previously known errors as well as adds some new functions.

NEEDED TOOLS: HAND TOOLS, a set of EPROM's version 4.0 (3 pcs.), and evt. wires for GND connection.

DESCRIPTION:

When updating the firmware-version, be sure to check also the electrical connection from the powercord GND to the cabinet GND and PCB GND.

From the powerconnector GND pin to the metallic cabinet must be a resistance of less than 1 ohm (typ. 0.2 ohm). This also applies to pin 1 on the transceiver connector. In case the connections are out of limits, rewire the GND connections, so that they are fastened with a solder lug and a screw to the stay nut close to port connector 7. If necessary a pre-cut wiring can be ordered from the production.

MISCELLANEOUS FIELD CHANGE NOTICE NO. 12 (replaces nr.12
of 871023)

DATE: 880225

MODULE: Network Terminal Controller. NTC.

CATEGORY: PRODUCTION CHANGE

IN THE FIELD: TO BE MADE WHEN ERROR OCCURS

CORRECTS THE ERROR:

New Intel 8085A-2 processors will not work properly with Zilog 8038A FIFO because of timing problems during IO write cycle. The NTC then seems inoperative as the two processors in the NTC fail to communicate.

Processorchips manufactured before 1987 seem to function correctly but the timing may be marginal during FIFO write, which occasionally may cause an established connection to be disconnected.

It is therefore important to implement the change (mentioned below) on all NTC's.

The start of the WR signal from the 8085 to the 8038 must be delayed to ensure stable data during FIFO writestrobe.

NEEDED TOOLS: HAND TOOLS, THIN ISOLATED WIRE.

DESCRIPTION:

IC27 pin 4 must be disconnected from socket and wired to IC4 pin 8.

IC27 pin 36 must be disconnected from socket and wired to ICA9 pin 9.

The PCB revision is changed from A to B

MISCELLANEOUS FIELD CHANGE NOTICE NO. 10

DATE: 870831

MODULE: Network Terminal Controller. NTC.

CATEGORY: PRODUCTION CHANGE

IN THE FIELD: TO BE MADE AT A SUITABLE OCCATION

CORRECTS THE ERROR:

The Heartbeat Missing count in the NTC statistics information may indicate errors occuring even though the SQE pulse operates properly.

NEEDED TOOLS: HAND TOOLS, THIN ISOLATED WIRE.

DESCRIPTION:

IC29 pin 11,12, and 13 must be disconnected from the PCB.
ICF8 pin 9 must be disconnected from the PCB.

Then a wire is added to connect IC29 pin 11 to IC50 pin 2,
a wire is added to connect IC29 pin 12 to ICF7 pin 3,
a wire is added to connect IC29 pin 13 to IC31 pin 1, and
a wire is added to connect IC29 pin 7 to ICF8 pin 9,

MISCELLANEOUS FIELD CHANGE NOTICE NO. 6

DATE: 870422

MODULE: Network Terminal Controller. NTC.

CATEGORY: PRODUCTION CHANGE

IN THE FIELD: TO BE MADE IF A SEEQ 8023A IS USED TO REPLACE
A SEEQ 8023 IN EXISTING NTC'S

CORRECTS THE ERROR:

When using the new version (8023A) of Seeq's Manchester chip in the NTC, two problems have been observed:

During power-up CSN of the 8023A may go into active low mode if there is traffic on the network and the transceiver is implemented using a National 8392 chip.

Second, datapackages may be lost (20 to 50% of all packages may be disregarded), if the 8003 controller chip used with the 8023A chip has a weekcode 8452 or earlier.

These problems are not present using the 8023 chip with any 8003 controller chip.

Both problems can be avoided by observing the following:
When the Seeq 8023A is used in the NTC, the 8003 controller chip MUST have a weekcoding of 8601 or later, and pin 3 of the 8023A must be wired to IC17 pin 2, not directly to Vcc.

NEEDED TOOLS: HAND TOOLS.

DESCRIPTION:

Before inserting Seeq 8023A (IC1), bend pin 3 to avoid its connection to Vcc. Then connect pin 3 to IC17 pin 2.

Check weekcode of Seeq 8003 (IC2). If earlier than 8601 then replace IC2.

(P.S. The NTC TEST EPROM for CPU1 is now to be version 4.4)

MISCELLANEOUS FIELD CHANGE NOTICE NO. 4

DATE: 870223

MODULE: Network Terminal Controller. NTC.

CATEGORY: PRODUCTION CHANGE

IN THE FIELD: TO BE MADE AT A SUITABLE OCCATION.

CORRECTS THE ERROR:

The transceiver cable connector may occasionally loose contact on one of its pins. The connector cannot be fully inserted in the socket, because the socket has been mounted from the inside of the cabinet. THE CONNECTOR MUST BE MOUNTED ON THE OUTER SURFACE OF THE CABINET TO ENSURE A RELIABLE CONNECTION TO THE TRANSCEIVER CABLE.

NEEDED TOOLS:

HAND TOOLS.

DESCRIPTION:

Remove slidelock assembly, transceivercable connector, and flatcable from NTC.

Insert the flatcableconnector through the cutout for the transceiverconnector and reassemble the slidelock/cable connector.

MISCELLANEOUS FIELD CHANGE NOTICE NO. 3

DATE: 861203

MODULE: Network Terminal Controller. NTC.

CATEGORY: PRODUCTION CHANGE.

IN THE FIELD: TO BE MADE AT A SUITABLE OCCATION.

CORRECTS THE ERROR:

Common mode bias voltage to the manchester decoder is out of range as the values of resistors R16, R17, R18, and R19 has been interchanged in the parts list.

NEEDED TOOLS:

Hand tools.

DESCRIPTION:

Resistor R16 and R18 should be interchanged.

Resistor R17 and R19 should be interchanged.

The correct values of these resistors are:

R16: Resistor 2k43

R17: Resistor 2k43

R18: Resistor 5k6

R19: Resistor 5k6

MISCELLANEOUS FIELD CHANGE NOTICE NO. 2

DATE: 860307

MODULE: Network Terminal Controller. NTC.

CATEGORY: PRODUCTION CHANGE.

IN THE FIELD: TO BE MADE AT A SUITABLE OCCATION.

CORRECTS THE ERROR:

The NTC may occasionally disconnect established path.

NEEDED TOOLS:

Hand tools. One IC type SN74ALS74AN. Insulated wire.

DESCRIPTION:

Disconnect IC48 pin 1 from IC2 pin 19 by cutting the wire on PCB layer 1, component side, as indicated.

Add new IC (SN74ALS74AN) on top of IC34 soldering pin 1, 2, 3, 4, 7, 10, 13, and 14 directly to the pins of IC34. Pin 5, 6, and 8 of the new IC remain not connected.

Connect pin 9, 11, and 12 as follows:

Connect new IC pin 9 to IC48 pin 1 with insulated wire on component side.

Connect new IC pin 11 to IC50 pin 10 with insulated wire on component side.

Connect new IC pin 12 to IC2 pin 19 with insulated wire on component side.

L7 L6 L5 L4 L3 L2

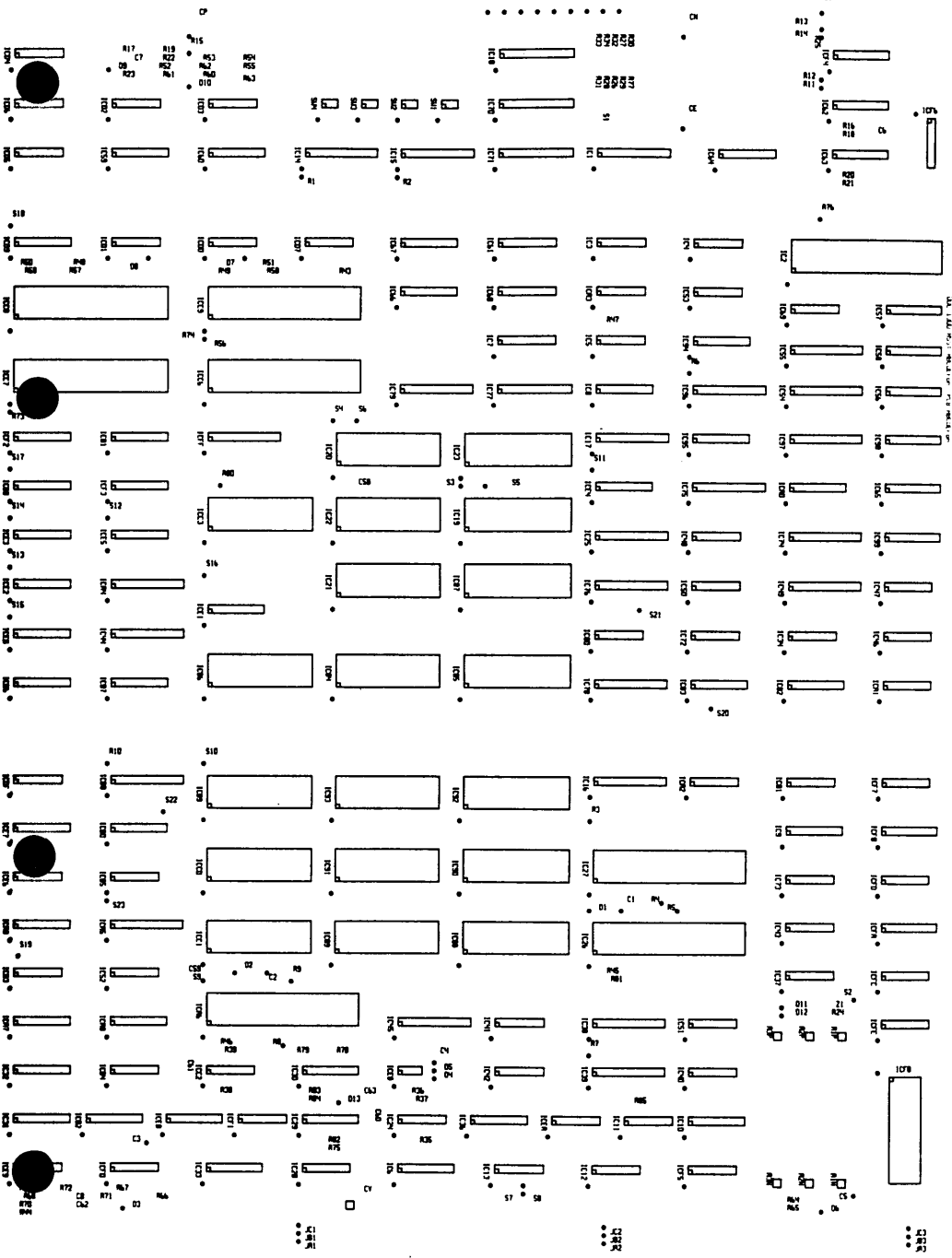

ALL DIMENSIONS RELATIVE TO THIS DATUM

0.000

0.000

0.000

NTC VERSION 3

PCB LAYER 1 (comp. side)

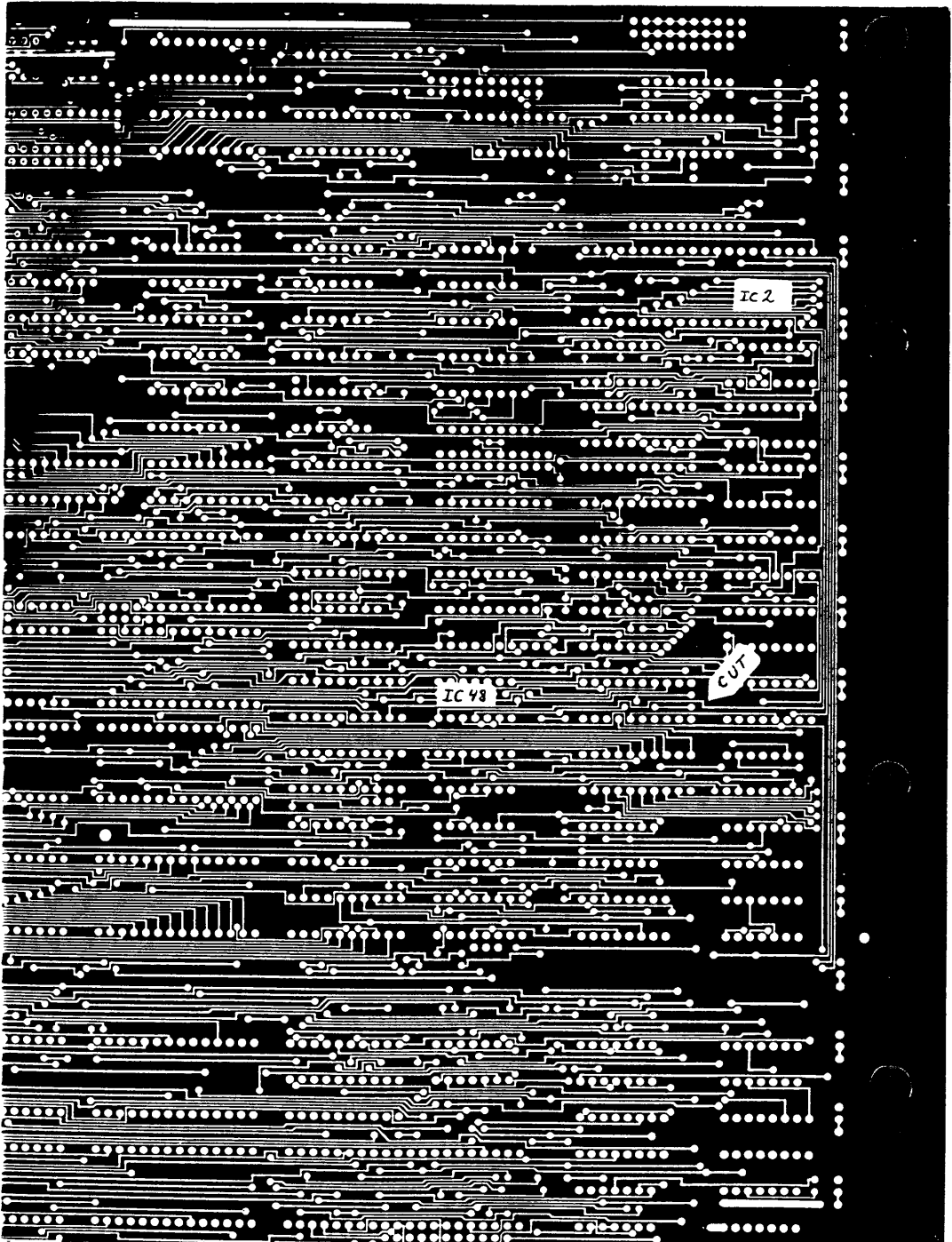

Supermax Field Change Notice no. 120

Module: NTC2, PCB 1310 ISS 2 and 3. - FCN no 5.

Date: 93-01-04

Category:

- Production change.
- In the field, if PAL in position IC44 is changed to NTC441. (This is not done by this FCN.)

Corrects the error:

- Reset problem when changing PAL device type.

Needed tools:

Hand tools.

Supermax FCN kit 120, stock number 95101200, consisting of:

1. One Smart Reset component H6052-2.

Description:

1. Do not mount (or remove) the following components: CC0, D0, D4, D5, R8, R9, R10, R35.
2. Mount the H6052-2 in the following position on the PCB:
H6052-2 pin 1 in CC0 pin 2.
H6052-2 pin 2 in R9 pin 2.
H6052-2 pin 3 in D0 pin 1.
3. Update the ASSY revision field from D to E by removing the letter D.

Circuits involved:

Name	Type	Position
CC0	Cap	H11
D0	Diode	H11
D4	Diode	H11
D5	Diode	G11
R8	Res	H11
R9	Res	H10
R10	Res	H11
R35	Res	G10

MISCELLANEOUS FIELD CHANGE NOTICE NO. 31

DATE: 900131

MODULE: Supermax NTC2 1310.

CATEGORY: PRODUCTION CHANGE.

IN THE FIELD: TO BE MADE IN CASE OF ERROR.

CORRECTS THE ERROR:

Error in test H at high temperature.

NEEDED TOOLS:

Hand tools.
Solder iron.
One ic 74act74.
One oscillator 40Mhz.
One resistor 1k ohm.
Piece of wire.

DESCRIPTION:

Remove the 20Mhz oscillator (ic12) and the 74as1004.
Solder one 74act74 at ic12 with pin 11 bent clear of the pcb.
On the solder side connect pin 1,2,3,4 to one end of the resistor,
and the other side of the resistor to pin 13 and 14 of the 74act74.
On the solder side connect pin 10 to 11 and pin 8 to 12.
Depending on the size of the 40Mhz oscillator do either A or B.
A. If the 40Mhz oscillator is a size 8 pin device.
Place the oscillator on top of the 74act74 with:
Pin 1 to pin 1, pin 4 to pin 4, pin 5 to pin 11 of the 74act74
(keep clear of the pcb) and pin 8 to pin 14 of the 74act74.
B. If the 40Mhz oscillator is a size 14 pin device.
Place the oscillator on top of the 74act74 with
Pin 1 to pin 1, pin 7 to pin 7 pin 8 to pin 11 of the 74act74
(wire) and pin 14 to pin 14.

The effect is that the oscillator is now buffered by the 74act74 and
divided by two giving nearly 50% duty cycle to the manchester encoder

Change PCB revision to B by removing the letter A in the PCB rev.
NO change in ASSY revision .

MISCELLANEOUS FIELD CHANGE NOTICE NO. 30

DATE: 900123

MODULE: Supermax NTC2 1310.

CATEGORY: PRODUCTION CHANGE.

IN THE FIELD: TO BE MADE IN CASE OF ERROR.

CORRECTS THE ERROR:

Error in test C at high temperature.

NEEDED TOOLS:

Hand tools.
One pal NTC241.

DESCRIPTION:

Replace pal NTC240 (ic24) with NTC241.

NO change in PCB revision .
Change ASSY revision to D by removing the letter C in the ASSY rev.

MISCELLANEOUS FIELD CHANGE NOTICE NO. 29

THIS FIELD CHANGE NOTE HAS BEEN SUPERSEDED BY MFCN31.

DATE: 891221

MODULE: Supermax NTC2 1310.

CATEGORY: PRODUCTION CHANGE.

IN THE FIELD: TO BE MADE IN CASE OF ERROR.

CORRECTS THE ERROR:

Error in test H at high temperature.

NEEDED TOOLS:

Hand tools.
Solder iron.
One ic 74as1004.
One oscillator 20Mhz.

DESCRIPTION:

Replace the 20Mhz oscillator (ic12) with one 74as1004.
Solder the new 20Mhz oscillator on top of the 74as1004,
with corner pin 1 of the oscillator to pin 1 of the
74as1004, pin 7 to pin 7, pin 14 to pin 14 and corner
pin 8 of the oscillator bendt to pin 9 of the 74as1004.
The effect is that the oscillator is now buffered by
one of the inverters in the 74as1004.

NO change in PCB revision .

Change ASSY revision to C by removing the letter B in the ASSY rev.

MISCELLANEOUS FIELD CHANGE NOTICE NO. 28

DATE: 891204

MODULE: Supermax NTC2 1310.

CATEGORY: PRODUCTION CHANGE.

IN THE FIELD: TO BE MADE IN CASE OF ERROR.

CORRECTS THE ERROR:

Memory error in test A at high temperature.

NEEDED TOOLS:

Hand tools.

One pal code ntc221.

DESCRIPTION:

Replace pal ntc220 (ic22) with ntc221.

NO change in PCB revision .

Change ASSY revision to B by removing the letter A in the ASSY rev.

Miscellaneous Field Change Notice no. 37

Module: 2500 CPU board for the SGD.

Date: 91.01.18

Category:

- Production change.
- In the field, in case of error.

Corrects the error:

- The SGD does not function due to defective battery backup SRAM's.

Needed tools:

Hand tools.

Solder iron.

Supermax MFCN kit 037, stock number 95120370, consisting of:

1. Two 28 pins sockets.
2. Two SEEQ 28C64 EEPROM's.

Description:

Replace the two backup sockets, CL09 and CL10. Replace the two SRAM's with the two SEEQ 28C64 EEPROM's from the MFCN kit.

Circuits involved:

Name	Type	Position
CL09	memory	Module 2500
CL10	memory	Module 2500

No change in PCB or ASSY revision.

MISCELLANEOUS FIELD CHANGE NOTICE NO. 15

DATE: 880207

MODULE: Supermax Graphics Display 2500 with 2500ACC board.

CATEGORY: PRODUCTION CHANGE.

IN THE FIELD: TO BE MADE AT A SUITABLE OCCASION.

CORRECTS THE ERROR:

The SGD accelerator board (68020) may not work properly with eeproms.
The SGD accelerator board (68020) may not work properly with duart
channel 4 and 5.

NEEDED TOOLS:

Solder iron.
One Pal GS04H-B.
Insulated wire.
One 16 pin socket.
One 74S74 and one 74LS390.

DESCRIPTION:

The corrections must only be made on 2500 alfa boards with
2500ACC accelerator mounted.

EEPROM function with accelerator board:

Replace pal GS04 with GS04H-B solder a wire from CP15 pin 7 to
CL08 pin 4.

DUART function with accelerator board:

Remove IC CP17 and CP19.

Solder sockets in position CP17.

Place one 74S74 at position CP19 with pin 5 lifted.

Place one 74LS390 in socket at position CP17 with pin 1 lifted.

Solder a wire between pin 1 of the 74LS390 and pin 5 of the 74S74
(the short curcuit between pin 3 and 5 of CP19 on the pcb
should be kept intact).

The corrections made does not affect pcb or assy revision level
since the corrections made is a deviation from the normal 68000
based board, however the corrections does constitute a change,
and a label 2500-2500A REV A should be placed on the 2500 alfa
board between the edge and component C12V and C12V-.

MISCELLANEOUS FIELD CHANGE NOTICE NO. 13

DATE: 871112

MODULE: Supermax Graphics Display.

CATEGORY: PRODUCTION CHANGE.

IN THE FIELD: TO BE MADE AT A SUITABLE OCCASION.

CORRECTS THE ERROR:

The SGD accelerator board (68020) may behave erratically.

NEEDED TOOLS:

Hand tools.

Solder iron.

Three single in line resistor network with 9 3k3 resistors.

One 3k3 resistor.

Insulated wire.

DESCRIPTION:

On the accelerator board.

!Beware of orientation since the 68000 socket is mirrored with respect to the components on the board.

Solder one sil with pin 1 to pin 49 of the 68000 socket and the 9 resistors to pin 48,47,46,45,44,43,42,41,40.

Solder one sil with pin 1 to the decoupling capacitor vcc pin and pin 4 to 33,5 to 34,6 to 35,7 to 36,8 to 37,9 to 38,10 to 39.

Solder one sil with pin 1 to the decoupling capacitor vcc pin and pin 5 to 32,6 to 31,7 to 30,8 to 29,9 to 28,10 to 27.

The cdis signal of the 68020 (pin H1) should be pulled up ,
The resistor should be placed alongside the 74S74 in the holes at pin 14 and 10 of the 74S74 (5.08 millimeters from the 74S74).

On the 2500 ALFA board.

Short circuit pin 60 and pin 59 of CP10.

Pin 1 of 3K3 to VCC

Pin 1 of 3K3 to VCC

Pin 1 of 3K3 to VCC

3K3 RESISTOR

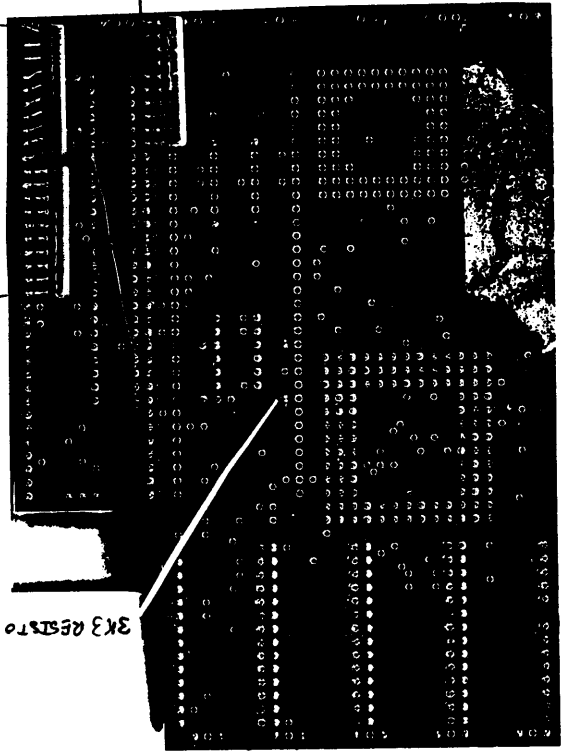

MISCELLANEOUS FIELD CHANGE NOTICE NO. 11

DATE: 870909

MODULE: Supermax Graphic Display. SGD.

CATEGORY: PRODUCTION CHANGE

IN THE FIELD: TO BE MADE WITHOUT ANY UNNECESSARY DELAY

CORRECTS THE ERROR:

When used on Ethernet, some SGD's may fail to execute the "Connect" command until appr. 5 minutes after power-on.

NEEDED TOOLS:

HAND TOOLS, THIN ISOLATED WIRE

DESCRIPTION:

Pin 29 of CE04 on the alfa board (2500) must be connected to GND (CE05 pin 10).

PCB version is changed from A to B.

Miscellaneous Field Change Notice no. 38

Module: 2510 CPU board for the SGD.

Date: 91.01.10

Category:

- Production change.
- In the field, in case of error.

Corrects the error:

- The SGD does not function due to blown F12VP fuse.

Needed tools:

Hand tools.

Solder iron.

Supermax MFCN kit 038, stock number 95120380, consisting of:

1. One 1.5 Amp picofuse.

Description:

Replace the blown F12VP fuse with the fuse in the MFCN kit. A blown fuse is normally indicated, if the transceiver does not turn on the LED, when the SGD box is powered on.

Circuits involved:

Name	Type	Position
F12VP	1.5A picofuse	Module 2510

No change in PCB or ASSY revision.

MISCELLANEOUS FIELD CHANGE NOTICE NO. 27

DATE: 891127

MODULE: Supermax Graphics Display. 2510

CATEGORY: PRODUCTION CHANGE.

IN THE FIELD: TO BE MADE IN CASE OF ERROR.

CORRECTS THE ERROR:

The 2510 board exhibits faults in the test of the alfa palette (test C).

NEEDED TOOLS:

Hand tools.
One pal SG081.

DESCRIPTION:

Replace SG080 (CP08) with SG081.

NO change in PCB revision .
Change ASSY revision to C by removing the letter B.

MISCELLANEOUS FIELD CHANGE NOTICE NO. 20

DATE: 881128

MODULE: Supermax Graphics Display. 2510

CATEGORY: PRODUCTION CHANGE.

IN THE FIELD: TO BE MADE AT A SUITABLE OCCASION.

CORRECTS THE ERROR:

Test program reports error on serial channels 4 and 5.
Altered memory layout for the 1Mbyte version of the 2510.
The test program reports error on the EEPROM.
Missing VCC connection to 81C51.

NEEDED TOOLS:

Hand tools.
Solder iron.
One eeprom containing firmware 2510-1.0 .
One pal SG271.
One pal SG311.
One pal SG011.
One 3K3 ohm resistor.
Insulated wire.
mfcn21.

DESCRIPTION:

Solder wire from 81C51 pin 61 to 81C51 pin 47.
Solder a 3K3 resistor from CC12 pin 8 to CS32 pin 20 (VCC).
Change current firmware (CP34) to revision 1.0.
Replace SG270 with SG271 (CP27).
Replace SG310 with SG311 (CP31).
Replace SG010 with SG011 (CP01).
Change strapping of ST2 pin 1 and 2 should be short circuited.
perform adjustment procedure .

Remove the letter A in the PCB revision.
Remove the letter A in the Assy revision.

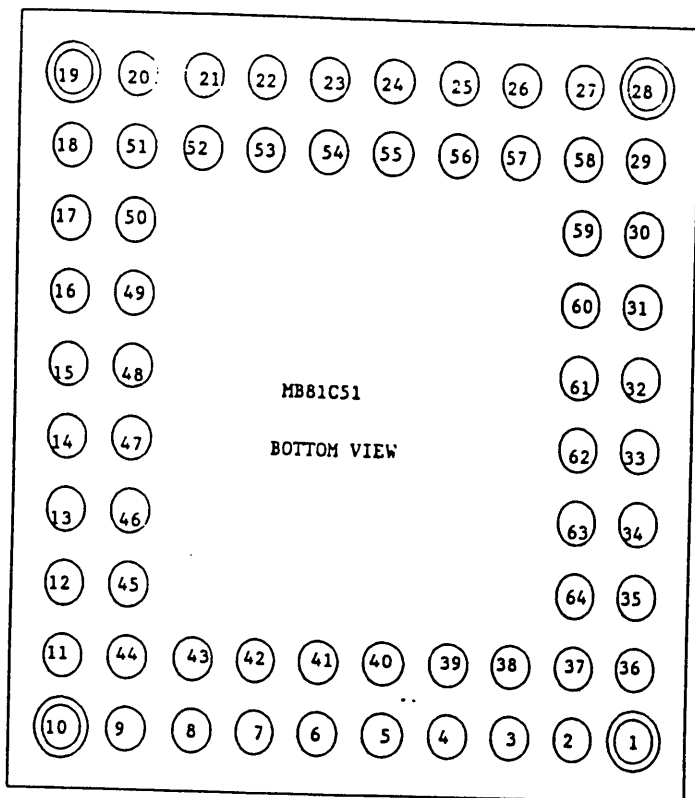

PIN FUNCTION:

PIN No.	FUNCTION	PIN No.	FUNCTION	PIN No.	FUNCTION
1	N.C.	23	A4	45	TD6
2	MHIT	24	A5	46	TD9
3	HIT0/REP0	25	A7	47	VCC
4	HIT2/REP2	26	A9	48	TD13
5	HIT3/REP3	27	N.C.	49	TD15
6	TD0	28	N.C.	50	TD17
7	TD2	29	FINV	51	TD19
8	EXTH	30	SELK	52	A0
9	MHENBL	31	SE1	53	A2
10	N.C.	32	IN#	54	GND
11	TD7	33	INVL	55	A6
12	TD8	34	SET	56	A8
13	TD10	35	H/R	57	PURGE
14	TD11	36	HIT	58	MODE
15	TD12	37	HCO/RCO	59	VINV
16	TD14	38	HCl/RC1	60	SBO
17	TD16	39	HIT1/REP1	61	VCC
18	TD18	40	GND	62	WRITE
19	N.C.	41	TD1	63	RLATCH
20	N.C.	42	TD3	64	PERR
21	A1	43	TD4		
22	A3	44	TD5		

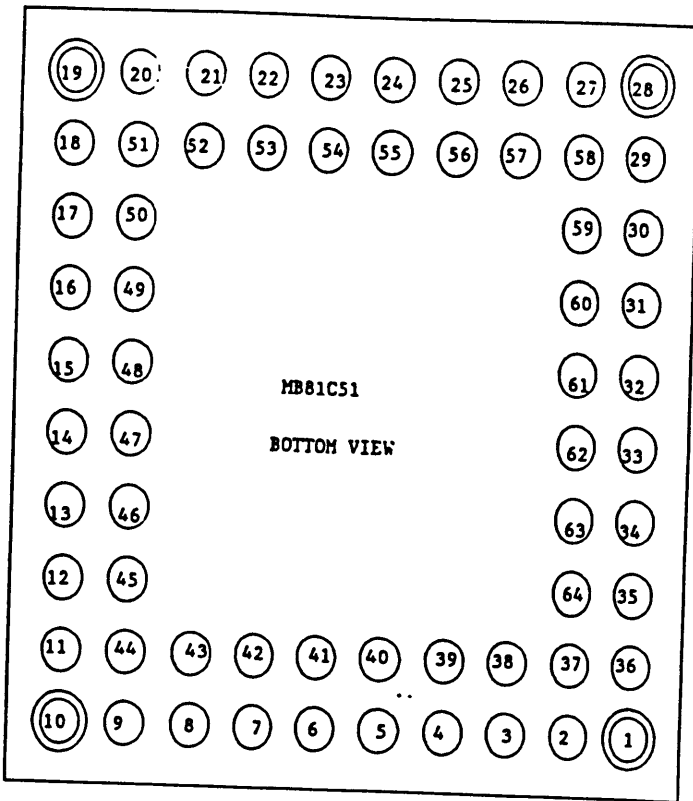

PIN FUNCTION:

PIN No.	FUNCTION	PIN No.	FUNCTION	PIN No.	FUNCTION
1	N.C.	23	A4	45	TD6
2	MHIT	24	A5	46	TD9
3	HIT0/REP0	25	A7	47	VCC
4	HIT2/REP2	26	A9	48	TD13
5	HIT3/REP3	27	N.C.	49	TD15
6	TD0	28	N.C.	50	TD17
7	TD2	29	FINV	51	TD19
8	EXTH	30	SELK	52	A0
9	MHENBL	31	SEL	53	A2
10	N.C.	32	IN2	54	GND
11	TD7	33	INVL	55	A6
12	TD8	34	SET	56	A8
13	TD10	35	H/R	57	PURGE
14	TD11	36	HIT	58	MODE
15	TD12	37	HCO/RCO	59	VINV
16	TD14	38	HC1/RC1	60	SBO
17	TD16	39	HIT1/REP1	61	VCC
18	TD18	40	GND	62	WRITE
19	N.C.	41	TD1	63	RLATCH
20	N.C.	42	TD3	64	PERR
21	A1	43	TD4		
22	A3	44	TD5		

Miscellaneous Field Change Notice no. 36

Module: Power supply dde019 (SGD).

Date: 90.11.09

Category:

- Production change.
- In the field, in case of error.

Corrects the error:

- The SGD does not function due to lack of -5V.

Needed tools:

Hand tools.

Solder iron.

Supermax MFCN kit 036, stock number 95120360, consisting of:

1. One capacitor 0.22uF 250V~, Phillips type 368-40224.
2. One label to be placed on module L -5V indicating the change.

Description:

In the power supply dde019 (SGD) remove C1 and C5 in the -5V supply module.

Replace C5 with the new capacitor (0.22uF).

The position containing C1 is left empty.

Place label on module L.

Circuits involved:

Name	Type	Position
C1	capacitor	Module L -5V
C5	capacitor	Module L -5V

No Change in PCB or ASSY revision .

Miscellaneous Field Change Notice no. 35

Module:	SGD Graphic board 2600
Date:	90.08.24

Category:

- Production change.
- In the field, in case of error.

Corrects the error:

- Display changes position with heavy drawing activity.
- Display jitters.
- Correction to Miscellaneous Field Change Notice no. 33.

Needed tools:

- Hand tools.

Supermax MFCN kit 035, stock number 95120350, consisting of:

1. One pal CG32C.

Description:

- Remove pal CG32B.
- Insert CG32C in socket CG32 with pin 6 bent away from socket.
- Solder wire from CG32C pin 6 to CG14 pin 2.
- Change PCB revision to D by removing the letter C in the PCB revision.

Circuits involved:

Name	Type	Position
CG14	CG14A pal	CG14
CG32	CG32C pal	CG32

Miscellaneous Field Change Notice no. 33

Module: SGD Graphic board 2600

Date: 90.06.7

Category:

- Production change.
- In the field, in case of error.

Corrects the error:

- Display changes position with heavy drawing activity.
- Display jitters.

Needed tools:

Hand tools.
Solder iron.
Insulated wire.

Supermax MFCN kit 033, stock number 95120330, consisting of:

1. One pal CG32B.

Description:

Detach IC1 pin 10 from PCB. Remove pal CG32A.B.
Solder wire from CG14 pin 1 to CG32 pin 1 (solder side).
Solder wire from CG32 pin 14 to CG05 pin 2 (solder side).
Insert CG32B in socket CG32 with pin 6 bent away from socket.
Solder wire from CG32B pin 6 to CG14 pin 2.

Circuits involved:

Name	Type	Position
CG32	CG32B pal	CG32
IC1	74AS04	IC1
CG14	CG14A pal	CG14
CG05	CG05D pal	CG05

Change PCB revision to C by removing the letter B in the PCB revision.

MISCELLANEOUS FIELD CHANGE NOTICE NO. 25

DATE: 890821

MODULE: Supermax Graphic Display SGD Graphic Board 2600.

CATEGORY: PRODUCTION CHANGE.

IN THE FIELD: TO BE MADE WHEN ERROR OCCUR.

CORRECTS THE ERROR:

When using a Hitachi Graphic Controller HD 63484 from 1989 or later on the SGD Graphic Board 2600, the counter CG39 may count too many pulses resulting in a vertical white or coloured line in the left side of the display.

The correction mentioned below should be implemented when using or replacing CG12 with an IC of weekcode 9C1 or higher.

NEEDED TOOLS:

Hand tools. Thin wire.

DESCRIPTION:

Disconnect CG39 pin 9 from the PCB and connect it to CG29 pin 9 using a thin wire.

Change revision level to D by removing the letter C in the ASSY identification on the component side of the board.

MISCELLANEOUS FIELD CHANGE NOTICE NO. 22 A

Replaces MFCN 22 Date 881112
Misspelling in part numbers of resistor network.

DATE: 881214

MODULE: Supermax Graphics Display 2600.

CATEGORY: PRODUCTION CHANGE.

IN THE FIELD: TO BE MADE AT A SUITABLE OCCASION.

CORRECTS THE ERROR:

The Palettes does not always display correct colors
in the 80MHZ version.

The correction has no effect on the 64MHZ version.

NEEDED TOOLS:

Hand tools.

Solder iron.

Two 220 ohm resistor networks (6X-1-221).

or two 56 ohm resistor networks (6X-1-560).

DESCRIPTION:

Solder one 220 ohm resistor network in parallel with ERb12.

Solder one 220 ohm resistor network in parallel with ERb13.

Both resistor networks are located at the edge of the

PCB above IC10 (palette chip).

Another possibility is to replace ERb12-ERb13 with 56 ohm
resistor networks.

Change the assy revision to C by removing the letter B in the
assy revision.

MISCELLANEOUS FIELD CHANGE NOTICE NO. 21

DATE: 881128

MODULE: Supermax Graphics Display 2600 with 2510 cpu board.

CATEGORY: PRODUCTION CHANGE.

IN THE FIELD: TO BE MADE AT A SUITABLE OCCASION.

CORRECTS THE ERROR:

Test program stops in test of graphics controller.
The field change note must only be carried out
when the 2600 is used with a 2510 cpu board.

NEEDED TOOLS:

Hand tools.
Solder iron.
One pal CG04E.
Insulated wire.
mfcn20.

DESCRIPTION:

Solder a wire from CG12 pin 8 to CG04 pin 20 (on solder side).
Change CG04D to CG04E (CG04).

MISCELLANEOUS FIELD CHANGE NOTICE NO. 16

DATE: 880207

MODULE: Supermax Graphics Display 2600.

CATEGORY: PRODUCTION CHANGE.

IN THE FIELD: TO BE MADE AT A SUITABLE OCCASION.

CORRECTS THE ERROR:

The SGD may not perform correctly when pixel transfers is made with firmware version 1.7 or later.

The SGD testprogram will stop in test D.

NEEDED TOOLS:

Solder iron.

One Pal CG04D.

DESCRIPTION:

Replace CG04? with CG04D.

If a wire is soldered to CG04 pin 23 this wire should be soldered to CG04D pin 23 (kept unchanged).

Change revision level to B by removing the letter A in the ASSY identification on the component side of the board.

MISCELLANEOUS FIELD CHANGE NOTICE NO. 9

DATE: 870828

MODULE: Supermax Graphic Display. SGD.

CATEGORY: PRODUCTION CHANGE

IN THE FIELD: TO BE MADE WITHOUT ANY UNNECESSARY DELAY

CORRECTS THE ERROR:

The communication between the CPU and the Graphic Controller or between the CPU and the palettes may sometimes be in error on the latest PCB version (2600) of the Graphic Board resulting in unfinished drawing commands (wrong or inconsistent shapes) or wrong colours.

NEEDED TOOLS:

HAND TOOLS.

DESCRIPTION:

On the graphic board (2600) pin 17 of CG05 must be disconnected.

(This version of the PCB layout can be identified by the presence of a strap SP right next to CG05).

MISCELLANEOUS FIELD CHANGE NOTICE NO. 7

DATE: 870716

MODULE: Supermax Graphic Display. SGD.

CATEGORY: PRODUCTION CHANGE

IN THE FIELD: TO BE MADE AT A SUITABLE OCCATION.
(when updating firmware to version 1.5)

CORRECTS THE ERROR:

When used with firmware version 1.5 or later, this modification makes it possible to update the colour palettes during VSYNC only, i.e. there will be no noise stripes on the display during palette updating.

NEEDED TOOLS:

HAND TOOLS.

DESCRIPTION:

On the graphics board (2600) two additions are to be made:

Solder a wire from CG12 pin 64 to IC9 pin 32.

Solder a wire from pin 1 to pin 5 on STRAPO.

Miscellaneous Field Change Notice no. 39

Module:	Supermax Graphic Display, SGD.
Date:	91.01.10

Category:

- Production change.
- In the field, in case of error.

Corrects the error:

- The SGD does not function due to a fault in the connection of the CPU board and the graphic board.

Needed tools:

Hand tools.

Supermax MFCN kit 039, stock number 95120390, consisting of:

1. Mounting bracket.
2. 6 pcs. short metal spacers.
3. 6 pcs. long metal spacers.
4. 5 pcs. nylon spacers
5. Miscellaneous screws and nuts.

Description:

To stabilise the connection between the CPU board and the graphic board the MFCN39 kit should be applied as specified below:

- The CPU board and the graphic board is removed.
- The short metal spacers is mounted in the existing stay nuts of the box.
- Replace the two existing metal spacers in the CPU board, with two long metal spacers.
- Insert the five nylon spacers in the mounting bracket and mount the CPU board onto the bracket, observing that the mounting holes are aligned.
- This frame is then mounted in the box, using the screws and the remaining long metal spacers.
- The graphic board is mounted and secured, using the remaining screws.

No change in PCB or ASSY revision .

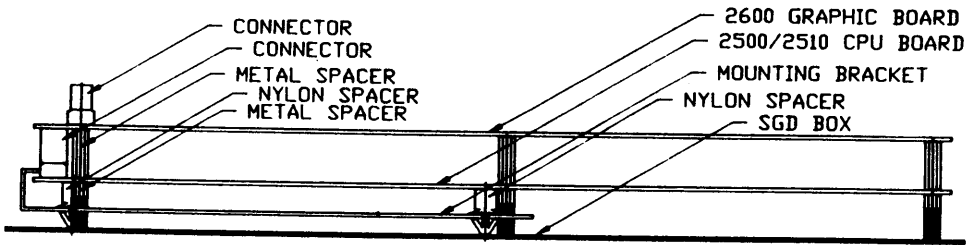

MISCELLANEOUS FIELD CHANGE NOTICE NO. 18

DATE: 880622

MODULE: Supermax Graphic Display SGD.

CATEGORY: PRODUCTION CHANGE

IN THE FIELD: TO BE MADE AT A SUITABLE OCCASION

CORRECTS THE ERROR:

The SGD may occasionally loose access to the setup values in backup RAM causing the SGD to be unable to start on power-up or to fail to update setup values.

NEEDED TOOLS: HAND TOOLS, thin wire.

DESCRIPTION:

When using (or replacing) a Dallas DS1213C backup socket in positions CL09 or CL10 (on the alfa board) in stead of DS1213B, pins 26 and 28 must be connected together.

On present SGD's check as follows:

Measure the voltage on pin 26 of CL09. If the voltage differs from that of pin 28 of the same IC, then pin 26 and pin 28 must be connected by a thin wire on the solderside of the PCB.

Use the same procedure for CL10.

PCB version is changed from B to C.

MISCELLANEOUS FIELD CHANGE NOTICE NO. 17

(replaces nr.17
of 880224)

DATE: 880322

MODULE: Supermax Graphic Display SGD.

CATEGORY: PRODUCTION CHANGE

IN THE FIELD: TO BE MADE AT A SUITABLE OCCASION

CORRECTS THE ERROR:

The new firmware (a set of EPROM's) version 1.7 corrects all earlier known errors as well as adds some new functions.

NEEDED TOOLS: HAND TOOLS, a set of EPROMS's version 1.7, thin wire, eventually pals CG04D, CG05D and GS12C (if not factory mounted).

DESCRIPTION:

Before updating the SGD, all earlier fieldchange notes (no. 7, 8, 9, 11, and 16; if accelerator option installed also no. 13 and 15) must be made.

In case CL40 to CL47 are 8 pcs. of 27256 type EPROM, strap SEPR should be connected to the other position and GS12B changed to GS12C. If SEPR is not present (old PCB layout), consult the factory for modifications.

Ensure that positions CG04 and CG05 on the graphic board have pal versions CG04D and CG05D, and check that pin 2 on CG05 is wired to CG04 pin 23.

Finally IC40 pin 1 and pin 4 are wired together.

PCB version is changed from A to B.

MISCELLANEOUS FIELD CHANGE NOTICE NO. 14 (replaces nr.14
of 880106)

DATE: 880113

MODULE: SGD Data Tablet.

CATEGORY: PRODUCTION CHANGE

IN THE FIELD: TO BE MADE AT A SUITABLE OCCASION

CORRECTS THE ERROR:

The SGD Data Tablet (Summagraphics Bit Pad II) may sometimes continously transmit a "key pressed" message to the SGD although the buttons have not been touched at all.

NEEDED TOOLS: HAND TOOLS, 3 Resistors 3k3.

DESCRIPTION:

The Data Tablet is opened, and a 3k3 resistor is soldered in parallel to each of the three resistors R54, R55, and R56. These are located close to the connector for the detachable pad. The originally 10k pull up resistors are in this way modified to 2.5k.

On the serial number label is a 19 digit number. Digits 10 and 11 indicates production month and year, i.e. 77 indicates July 1987. From this month the correction has been implemented by the factory.

When updating older units, the serial number label is to be marked "rev.B".

MISCELLANEOUS FIELD CHANGE NOTICE NO. 8

DATE: 870716

MODULE: Supermax Graphic Display. SGD.

CATEGORY: PRODUCTION CHANGE

IN THE FIELD: TO BE MADE AT A SUITABLE OCCATION.

CORRECTS THE ERROR:

Positioning the alfa cursor on active background may sometimes result in a black line (one pixel wide) appearing right after the cursor. This can be corrected by adjusting PS02 on the alfa board. PS02 must be adjusted for minimum resistance. (the procedure mentioned earlier in note of 06.02.87 is not correct; please use the procedure described below).

NEEDED TOOLS:

HAND TOOLS.

DESCRIPTION:

Adjustment of potentiometer PS02 on alfa board must be as follows:

Adjust PS02 to minimum resistance (0 ohm) measured between pin 18 and pin 4 of CS31.

SECTION 3.0

BAIO301/302

1

MEM301

2

MMD301

3

CPU300/301

4

PMD301

5

SCU

6

7

8

OTHERS

9

10

Supermax Field Change Notice no. 158

Module: BAIO301, BAIO302 Basic I/O module.

Date: 96-01-25

Category:

- Production change.
- In the field: When a TPE301 submodule is installed.

Corrects the error:

The submodule interface locks up, when TPE301 acts as a master on the interface. HDLC301 and SCU302 are slave devices only. The operation of these submodules is independent of this error.

Symptoms: The submodule interface stops. System crash caused by time out on BAIO30x.

Needed tools:

68 pin PLCC extraction tool. 44 pin PLCC extraction tool. 20 pin PLCC extraction tool. Supermax FCN kit 158, stock number 95101580, consisting of:

1. One MACH labeled "BIO261".
2. One MACH labeled "BIO272".
3. One PROM labeled "FCN158".

Description:

- All previous FCNs for this module must be made.
- Replace MACH in position U180 with MACH labeled "BIO261". This circuit is labeled "BIO260" on BAIO301 and BAIO302.
- Replace MACH in position U186 with MACH labeled "BIO272". This circuit is labeled "BIO271" on BAIO301 and BAIO302.
- Replace FCN PROM in position U204 with new FCN PROM labeled "FCN158". This circuit is labeled "FCN156" on BAIO301 and BAIO302.
- Do not update the revision field. On BAIO301 and BAIO302 the field should be **REV: ABCDEFGHIJK**

Circuits involved:

Name	Type
U180	MACH210-15JC
U186	MACH220-15JC
U204	AM27519AJC

Previous FCN:

BAIO301: FCN156.

BAIO302: FCN156.

Supermax Field Change Notice no. 156

Module: BAI0301, BAI0302 Basic I/O module.

Date: 95-10-19

Category:

- Production change.
- In the field: Without any unnecessary delay.

Corrects the error:

Error in data transfer between SCSI data buffer and SCSI agent. Under certain circumstances the control logic starts simultaneous read and write block transfers.

Symptoms: SCSI channel stops. System crash caused by time out on BAI030x or parity error on BAI030x. Write data from SCSI is written in a wrong address in Global Memory.

Needed tools:

68 pin PLCC extraction tool.

Supermax FCN kit 156, stock number 95101560, consisting of:

1. One MACH labeled "BIO193".
2. One PROM labeled "FCN156".

Description:

- All previous FCNs for this module must be made. Replace MACH in position U108 with MACH labeled "BIO193". This circuit is labled "BIO191" on BAI0301 and "BIO192" on BAI0302.
- Replace FCN PROM in position U204 with new FCN PROM labeled "FCN156". This circuit is labled "FCN146" on BAI0301 and "FCN155" on BAI0302.
- Do not update the revision field. On BAI0301 and BAI0302 the field should be REV: ABCDEFGHIJK

Circuits involved:

Name	Type
U108	MACH220-15JC
U204	83S123AA

Previous FCN:

BAIO301: FCN146.

BAIO302: FCN155.

Supermax Field Change Notice no. 155

Module:	BAIO302 Basic I/O module.
Date:	95-10-10.

Category:

- Production change.
- In the field: when error occurs.

Corrects the error:

Clock skew between processor and memory controller. The memory controller will miss memory requests from the processor.
BAIO302 cannot boot. BAIO302 cannot execute memory test program. BAIO302 stops.

Needed tools:

44 pin PLCC extraction tool.
Supermax FCN kit 155, stock number 95101550, consisting of:

1. One MACH labeled "BIO201".
2. One MACH labeled "BIO221".
3. One PROM labeled "FCN155".

Description:

- Replace MACH labeled "BIO200" in position U110 with MACH labeled "BIO201".
- Replace MACH labeled "BIO220" in position U115 with MACH labeled "BIO221".
- Replace FCN PROM in position U204 with new FCN PROM labeled "FCN155".
- Do not update the revision field. Field should be REV: ABCDEFGHIJK

Circuits involved:

Name	Type
U110	MACH210-12
U115	MACH210-12
U204	83SL23AA

Previous FCN:

None

Supermax Field Change Notice no. 146

Module:	BAIO301-1 and BAIO301-2 Basic I/O module
Date:	95.04.04

Category:

- Production change.
- Mandatory field change.

Corrects the error:

This FCN must be performed in order to raise the BAIO301-1 to the production level of the BAIO301-2. Furthermore this FCN corrects various errors found on both BAIO301-1 and BAIO301-2.

Needed tools:

Hand tools.

Supermax FCN kit 146, stock number 95101460, consisting of:

- One Flash PROM labeled "BIO401".
- One Flash PROM labeled "BIO411".
- One Flash PROM labeled "BIO421".
- One Flash PROM labeled "BIO431".
- One MACH device labeled "BIO112".
- One MACH device labeled "BIO171".
- One MACH device labeled "BIO271".
- One MACH device labeled "BIO341".
- One PROM device labeled "FCN146".
- Three submodules connectors.

Description:

In the field, the FCN must be performed by replacing the module.

Corrections involved are:

1. SPC/3 Diagnostic programs cannot be booted from the floptical, if the floptical is not located on SCSI 1 and id 2.

- Change the Flash PROM U3 from **BIO430** to **BIO431**.
 - Change the Flash PROM U4 from **BIO420** to **BIO421**.
 - Change the Flash PROM U5 from **BIO410** to **BIO411**.
 - Change the Flash PROM U10 from **BIO400** to **BIO401**.
2. In SVR4 debugger mode, a contention-situation on the System Bus interface can arise. This can lead to component failure.
 - Change the device U57 from **BIO111** to **BIO112**.
 3. A disconnected or reconnected SCSI transfer to/from the System Bus can, in certain situations, fail.
 - Change the device U78 from **BIO170** to **BIO171**.
 4. Access to Submodules on some of the BAIO301-1 modules can cause an parity-error.
 - Change the device U186 from **BIO270** to **BIO271**.
 5. Not all submodule connectors are mounted on some of the BAIO301.
 - Additional connectors must be mounted.
 6. Some of the BAIO301-1 modules are not prepared for the guides on the rear SCSI connectors.
 - The SCSI connectors on these modules must have a 4 mm. hole drilled.
 7. Some of the BAIO301-1 modules can not be used in a machine with more than one BAIO301 and CPU module.
 - Change the device U195 from **BIO340** to **BIO341**.
 8. Change the FCN PROM U204 with the PROM labeled **FCN146**.

Previous FCN:

None.

Supermax Field Change Notice no. 147

Module:	MEM301-0 and MEM301-1 Memory base module
Date:	95.04.24

Category:

- Production change.
- In the field: When employing multiprocessor.

Corrects the error:

Multiprocessor systems with a CPU3xx module employing the gate array CA302 do not adhere to the original system bus protocol on a read and may thus cause the memory module to hang up the bus. The modified memory module will work both with the original and the modified protocol.

Needed tools:

Hand tools.

Supermax FCN-kit, stock number 95101470, consisting of:

- One PAL device labeled **M31092**.
- One PAL device labeled **M31101**.
- One PROM device labeled **FCN147**.

Description:

The following changes are required:

- Remove device **M31091** from socket U12.
- Remove device **M31100** from socket U15.
- Connect U12 pin 18 and U12 pin 19 using via-holes on the back.
- Cut the connection between U12 pin 19 and U12 pin 18 at pad 18 within the socket.
- Cut the connection between U13 pin 14 and U15 pin 6 at pad 6 within the socket.
- Connect U12 pin 18 to U15 pin 6 on the component side.
- Insert device **M31092** in socket U12.

- Insert device **M31101** in socket **U15**.
- Finally, replace the **FCN PROM** in **U38** with the new **FCN147**.

Previous FCN:

None.

Supermax Field Change Notice no. 145

Module:	MMD301-0 8-MB DRAM module. MMD302-0 32-MB DRAM module.
Date:	95.03.15

Category:

- Production change.
- Mandatory field change.

Corrects the error:

Total memory capacity currently cannot exceed 256 MB.

Needed tools:

Hand tools.

Description:

The inputs and outputs of the base address register must be swapped for bits 28 and 31 such that the PCB complies with the logic diagrams.

This requires the following changes on U82 (74F377):

- Lift pin 6,7,14, and 15.
- Connect pin 7 to pad 6.
- Connect pin 14 to pad 15.
- Connect pin 6 to via-hole of pad 7.
- Connect pin 15 to via-hole of pad 14.

Finally, strike out the "A" in the REV-field.

Previous FCN:

None.

Supermax Field Change Notice no. 149

Module:	CPU300-1 and CPU301-1 CPU module
Date:	95.11.20 (Revision 1)

Editorial change:

This FCN149 replaces the earlier FCN149 dated 95.09.01. The latter refers to the position of the FCN PROM as U72, which correctly should be U73. The device is still FCN149.

Category:

- Production change.
- Mandatory field change.

Corrects the error:

The module hitherto has been unable to operate at a bus frequency of 33.3 MHz. In addition, the module name on the front panel may be wrong.

Needed tools:

Hand tools.

Supermax FCN149-kit, stock number 95101490, consisting of:

- One PAL device labelled **C31022**.
- Five PAL labels **C31051**, **C31061**, 2x **C31071**, and **C31130**.
- Front panel marked **CPU300**.
- One PROM device labelled **FCN149**.

Description:

- U136: PAL **X31021** -> **C31022**.
- U22: PAL label **X31051** -> **C31051**.
- U138: PAL label **X31061** -> **C31061**.
- U139: PAL label **X31071** -> **C31071**.
- U141: PAL label **X31071** -> **C31071**.
- U126: PAL label **X31130** -> **C31130**.

- **U96:** Connect CY7B991 pin 4 and 32 (GND) together. Pin 1 is marked by an indented dot.
- **U96:** Connect CY7B991 pin 6 and 13 (via-hole, GND) together.
- **R60:** Remove the resistor located in the center of the connector side.
- If the module ID PROM claims that the module is a CPU300 then change the module front panel and return the old to the factory.
- Finally, replace the FCN PROM in U73 with the new FCN149.

Circuits involved:

Due to the idiosyncrasies of the ISO9000 requirements I shall reiterate the circuits involved:

- U136, U22, U138, U139, U141, U126: PAL
- U96: CY7B991
- R60: Resistor
- U73: PROM

Previous FCN:

None.

Supermax Field Change Notice no. 161

Module:	PMD303, Processor module, 200MHz, 1Mb cache. PMD304, Processor module, 200MHz, 4Mb cache.
Date:	96-07-08

Category:

- Production change.
- In the field, if error occurs.

Corrects the error:

Spurious cache error exceptions, resulting in the error message: "Global system interface parity error". If this FCN does not remove the error, the board is faulty and should be returned. This FCN also corrects the error, that a identification label is missing from the board.

Needed tools:

Hand tools.

Supermax FCN kit 161, stock number 95101610, consisting of:

1. One MACH pal labeled "INIT101".
2. One identification label with the text "PMD303".
3. One identification label with the text "PMD304".

Description:

- Replace MACH pal in position U16 with MACH pal labeled "INIT101".
- Place the label with the correct text, next to the revision field on the PCB.
- Update the revision field by removing the letter A.
New field should be REV: BCDEFGHIJK

Circuits involved:

Name	Type
U16	MACH110

Previous FCN:

None

Supermax Field Change Notice no. 152

Module: PMD301, Processor module, 150MHz, 1Mb cache.

Date: 95-09-19

Category:

- Production change.
- In the field, when updating to 25MHz system interface clock rate.

Corrects the error:

With a bus frequency of 33.3 MHz the interface frequency can be increased to 25 MHz. This FCN thus requires FCN149 and FCN150.

Needed tools:

Hand tools.

Supermax FCN kit 152, stock number 95101520, consisting of:

1. One MACH pal labeled "INIT75".

Description:

- Replace MACH pal in position U2 with MACH pal labeled "INIT75".
- Update the revision field by removing the letter A.
New field should be REV: BCDEFGHIJK

Circuits involved:

Name	Type
U2	MACH110

Previous FCN:

None

Supermax Field Change Notice no. 160

Module:	SCU302 Service Computer submodule.
Date:	96-04-16

Category:

- Production change.
- In the field: When error occurs or when a TPE301 submodule is installed.

Corrects the error:

Caused by a glitch on the trailing edge of the signal PAS, SCU302 interprets data on the bus as a new address and starts a new cycle. This faulty cycle may cause the submodule bus to lock up or may cause a parity error in a following read cycle to SCU302.

Symptoms: The submodule interface stops. System crash caused by time out on BAIO30x. Parity error.

Needed tools:

68 pin PLCC extraction tool.

Supermax FCN kit 160, stock number 95101600, consisting of:

1. One MACH labeled "SCU101".
2. One PROM labeled "FCN160".

Description:

- All previous FCNs for this module must be made.
- Replace MACH in position U6 labeled "SCU100" with MACH labeled "SCU101".
- Replace FCN PROM in position U10 labeled "FCN154" with new FCN PROM labeled "FCN160".
- Do not update the revision field.

The field should be **REV:ABCDEFGHIJK**

Circuits involved:

Name	Type
U6	MACH220-15JC
U10	AM27S19AJC

Previous FCN:

FCN154.

Supermax Field Change Notice no. 154

Module: SCU302, Service Computer submodule.

Date: 95-10-10.

Category:

- Production change.
- In the field: when error occurs.

Corrects the error:

PDP parity error on BAI030x. The parity error occurs, when BAI030x reads the content of the A/D-converters placed on SCU302.

Needed tools:

44 pin PLCC extraction tool.

Supermax FCN kit 154, stock number 95101540, consisting of:

1. One MACH labeled "SCU201".
2. One PROM labeled "FCN154".

Description:

- Replace MACH labeled "SCU200" in position U36 with MACH labeled "SCU201".
- Replace FCN PROM in position U10 with new FCN PROM labeled "FCN154".
- Do not update the revision field.
Field should be **REV: ABCDEFGHIJK**

Circuits involved:

Name	Type
U36	MACH210-15
U10	83S123AA

Previous FCN:

None

Supermax Field Change Notice no. 162

Module:	TPS301, Terminator Power Supply 2.1 V
Date:	96-10-11

Category:

- Production change.
- In the field, without any unnecessary delay.

Corrects the error:

Certain bus loading conditions may cause a momentary drop in the bus terminator voltage, which may exceptionally lead to a bus cycle error. A Non-Operator test (memory test) using the SMES Diagnostic Program will fail with global bus hang-up (time-out on BAIO30x) if this condition occur.

Needed tools:

Hand tools.

A short piece of mounting wire.

Description:

- Remove the inductors L11 and L21.
- Replace the inductors with short pieces of wire.
- Update the revision field by removing the letter A.
New field should be REV: BCDEFGHIJK

Previous FCN:

None

Supermax Field Change Notice no. 157

Module:	DBP302 Disk Backplane, 4 positions.
Date:	95-10-27.

Category:

- Production change.
- In the field: when error occurs.

Corrects the error:

LED's on hot-plug modules responds to wrong column addresses (addr. 8 to 11 instead of 0 to 3). Thus in UNIX the LED's do not seem to work.

Needed tools:

Hand tools.

Description:

- Solder a piece of wire from the via next to the text R9 to the via right above (close to the letter I in the text BPID2).
- Update the revision field. Field should be REV: BCDEFGHIJK

Previous FCN:

None

Supermax Field Change Notice no. 150

Module:	BPL304-0 and BPL304-1 Backplane
Date:	95.08.25

Category:

- Production change.
- Mandatory field change.

Corrects the error:

The backplane hitherto has been unable to operate at a bus frequency of 33.3 MHz due to limitations of the CPU30x module.

Needed tools:

Hand tools.

Supermax FCN150-kit, stock number 95101500, consisting of:

- One 66.666 MHz ECL osc.
- One modified 14-pin socket with four corner pins.
- One plastic strap.

Description:

- If a 66.666 MHz ECL osc. already is present, then skip to the updating of the E²PROM.

If a 50 MHz ECL osc. is present then remove it, or if a 50 MHz TTL osc. with a CCC301 Clock converter circuit are mounted then remove both. Unless a socket is already present, mount a modified socket with pin 1 is at the bottom left. Then mount a 66.666 MHz ECL osc. and tie it down with a plastic strap.

- Change the E²PROM parameters below using the **putsysid** command in response to the **SPC/3 >** prompt of the BAIO PROM monitor. Reset the system.

Backplane revision = **150** (FCN)
Global frequency = **33333000** (Hz)
Local frequency = **33333000** (Hz)

Previous FCN:

None.