

DANSK DATA ELEKTRONIK
ID-7003 INTERRUPT PRIORITY/REAL TIME
CLOCK MODULE

for the
ID-7000 MICROPROCESSOR SYSTEM

second edition

October 1977

author: Ole Lading

1. Function

The ID-7003 Interrupt Priority/real time clock module is used in configurations where I/O modules must be served by means of interrupts. The module plugs into the ID-7000 bus systems at any location. It is able to deal with incoming interrupt request lines $\overline{IR}(7:0)$ at 8 priority levels. The module sends an interrupt request to the CPU-module (via \overline{INT}) if at least one enabled interrupt request line is activated. The CPU-module replies to this by executing an interrupt-acknowledge machine cycle. In this cycle, the ID-7003 generates a restart instruction (RST 0,1,...7) corresponding to the interrupt request with highest priority. When the CPU replies to the interrupt request, the internal interrupt enable flip-flop of the 8080A is cleared to prevent more interrupts from being served. Acknowledgement of the interrupting I/O-unit and re-enabling of the interrupt system is under program control.

The ID-7003 module contains an interrupt mask register for selective enabling/disabling of the different priority levels. Loading and storing of the interrupt mask register is under program control. The module contains logic to sense the status of the internal interrupt enable flip-flop and the powerless line from the system power-supply.

The drivers of the interrupt request lines, $\overline{IR}(7:0)$, on the different I/O-modules are of the open collector type (with pull-up resistors on the ID-7003 module). This allows for a maximum of 8 interrupt sources to be connected to a single interrupt request line. In this way, the maximum number of direct interrupt

sources in the ID-7000 microprocessor system becomes 64.

The ID-7003 module also contains a real time clock. 3 clock rates (0,1 msec, 1 msec, and 10 msec) are derived from the 2MHz clock in the bus. One of these clocks may, by means of a strap, be used to set an RTC-flip-flop. The flip-flop may be connected to any of the 8 possible interrupt request lines, to generate an interrupt. The RTC-flip-flop is cleared under program control. The content of the flip-flop may be read as a part of the status word of the module.

Figure 1. shows a blocked schematic of the module.

Appendix 1. contains the detailed logic diagram of the module.

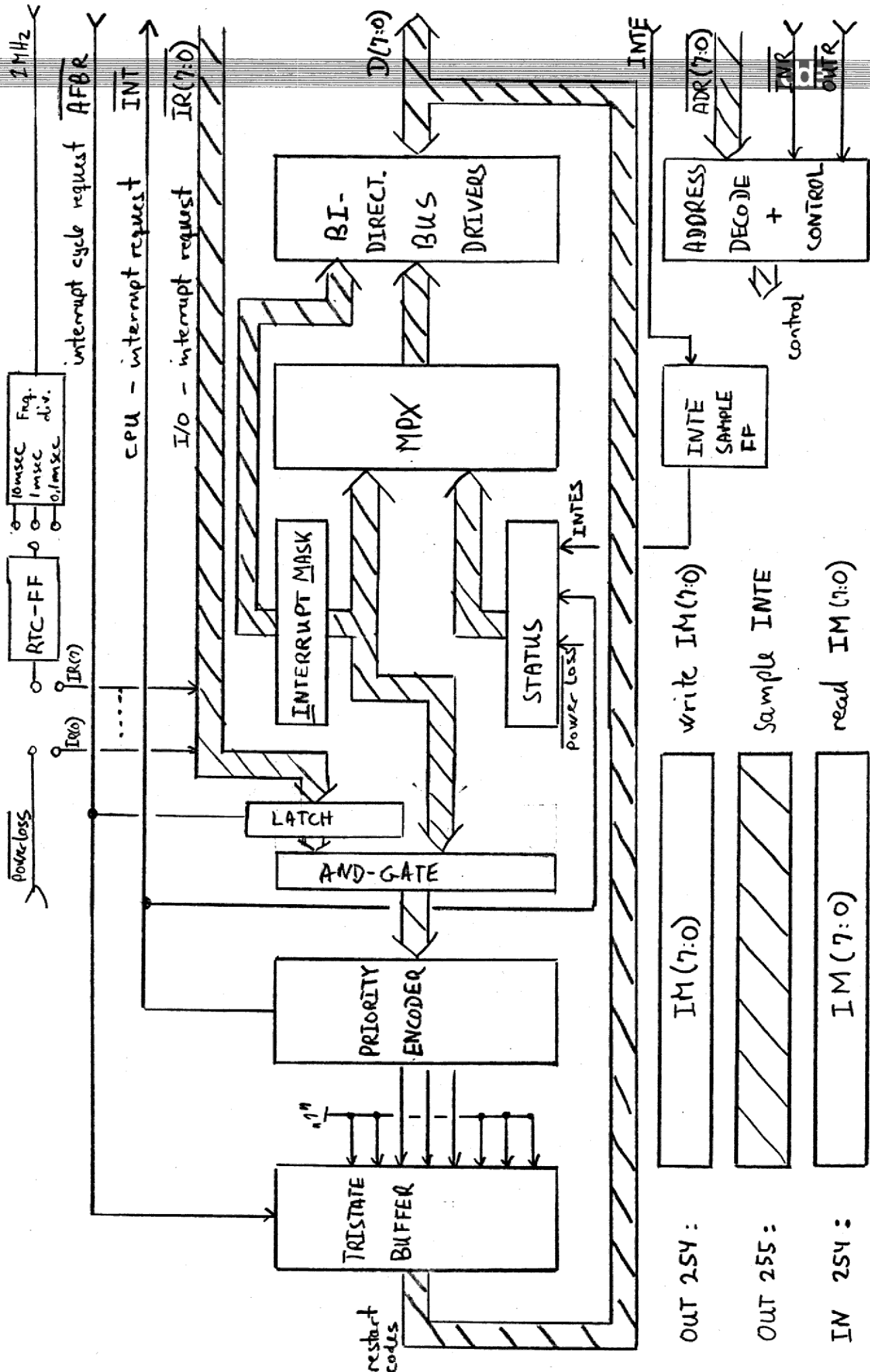

Fig. 1

2. Programming description

2.1 Interrupt priority: The ID-7003 Interrupt Priority module receives interrupt requests on the 8, active low, interrupt request lines $\overline{IR}(7:0)$ in the bus system. The module generates a RST-instruction corresponding to the activated interrupt request line with highest priority as follows:

$\overline{IR}(0)$: RST 0 instruction, highest priority
 $\overline{IR}(1)$: RST 1 instruction
 $\overline{IR}(2)$: RST 2 instruction
 $\overline{IR}(3)$: RST 3 instruction
 $\overline{IR}(4)$: RST 4 instruction
 $\overline{IR}(5)$: RST 5 instruction
 $\overline{IR}(6)$: RST 6 instruction
 $\overline{IR}(7)$: RST 7 instruction, lowest priority

2.2 Interrupt Mask register. The interrupt mask register $IM(7:0)$ controls selective enabling/disabling of the different interrupt request lines (interrupt levels). The interrupt mask register $IM(7:0)$ is loaded from the accumulator of the CPU by the OUT 254 instruction. Execution of the IN 254 instruction transfers of the contents of the interrupt mask register $IM(7:0)$ to the accumulator.

IM(7)	IM(6)	IM(5)	IM(4)	IM(3)	IM(2)	IM(1)	IM(0)
7	6	5	4	3	2	1	0

1 enable
 0 disable -----

2.3 Control Word. Executing of the OUT 255 instruction (contents of the accumulator irrelevant), causes transfer of the contents in the internal interrupt enable flip-flop, INTE, into a flip-flop, INTES, on the ID-7003 module. The INTES flip-flop is a part of the module status word (see section 2.4). Special logic on the module makes the OUT 255 instruction a non-interruptable instruction. This ensures that the succeeding instruction is always executed.

The purpose of these features is to allow a monitor program to sample the contents of the internal interrupt enable flip-flop before disabling the interrupt system. After this the monitor can read the previous status of the interrupt enable flip-flop, as shown in the following example:

```
MONITOR-ENTRY:  OUT 255
                  DI
                  PUSH PSW
                  PUSH B
                  PUSH D
                  PUSH H
                  IN 255
                  "
                  "
```

2.4 Status word. Execution of the IN 255 instruction transfers the contents of the module's statusword to the accumulator in the CPU. The status word contains the following information:

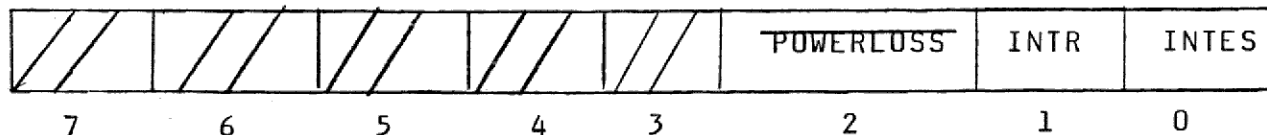

bit 0:	INTES	This status bit indicates the contents of the internal interrupt enable flip-flop of the CPU as sampled by the execution of the latest OUT 225 instruction. 0: Interrupt system was disabled 1: Interrupt system was enabled.
bit 1:	INTR	This signal from the interrupt priority logic indicates, when logical one, that at least one $IM(i) \cdot IR(i)$ equals logical one ($i=0,1,\dots,7$).
bit 2:	POWERLOSS	+) This status bit, connected to the powerloss line of the system power situation: 0: Powerloss error. 1: Power OK
bit 3-7		undefined, reserved for future use.

Reading the status word clears the RTC-flip-flop.

+) By means of a strap on the module, the powerloss line may be connected to the IR(0) request line.

Addr. decode, control, interrupt mask.

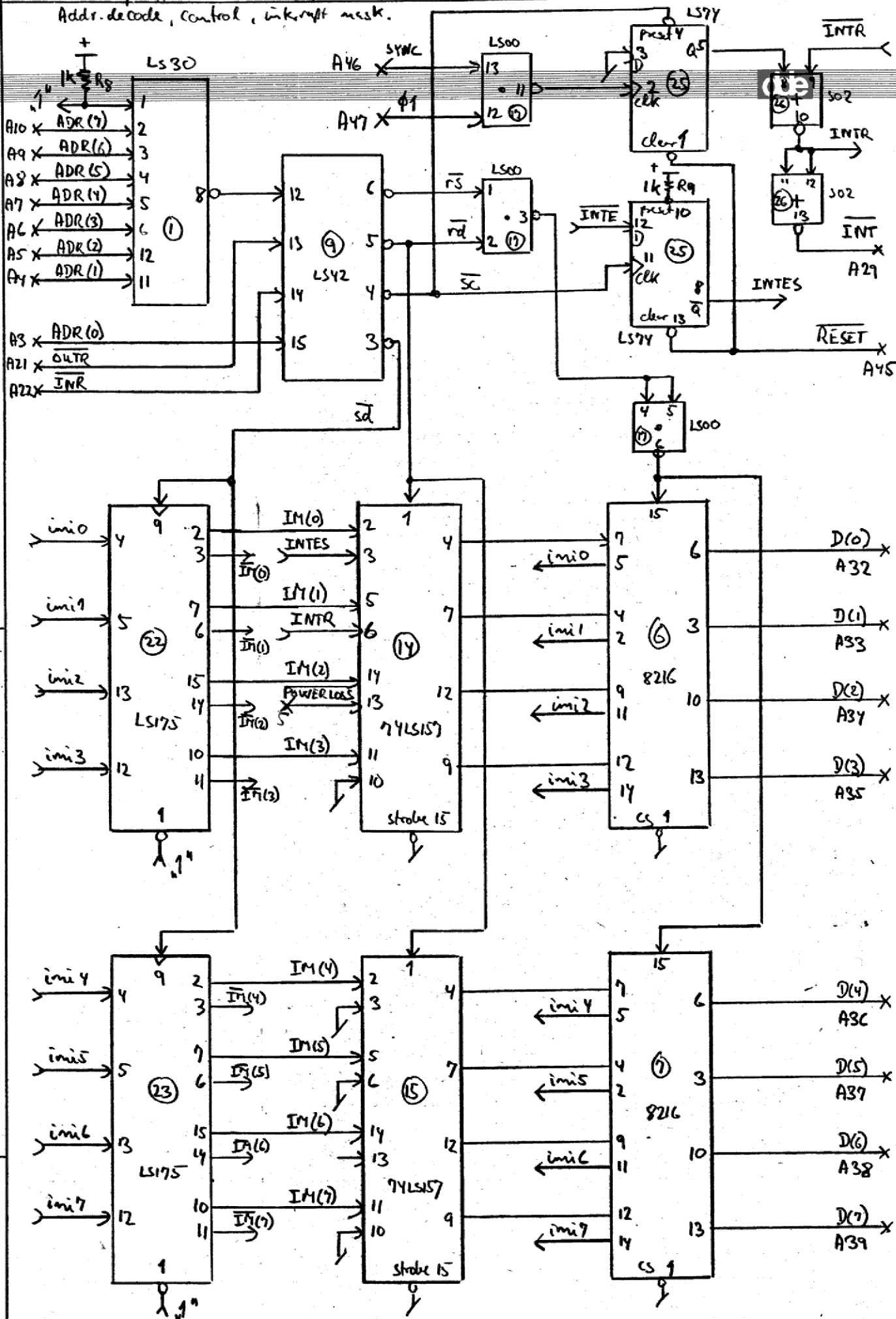

ID-7003, INTERRUPT PRIORITY - module
 Logic Schematic: Interrupt priority.

Initialer/dato
 Ole Lørdy
 Revideret

Side
 2 of 2
 Projekt
 ID-7000-system

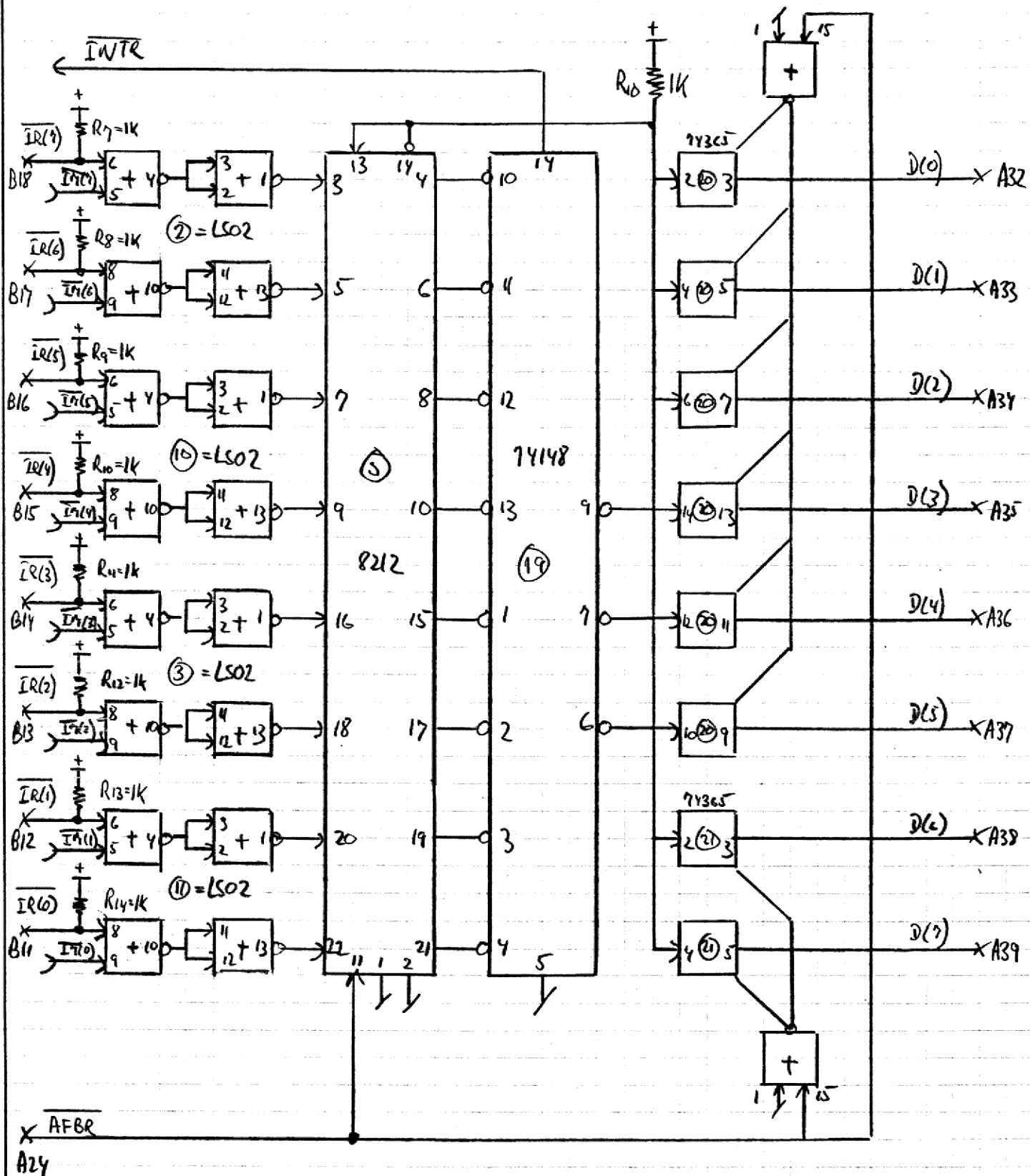

ID-7003 Interrupt priority module.
 Logic Schematic: Frequency divider, RTC-flip-flop.

Initialer/dato

OL

Side

3

Revideret

Projekt

ID-7000-system

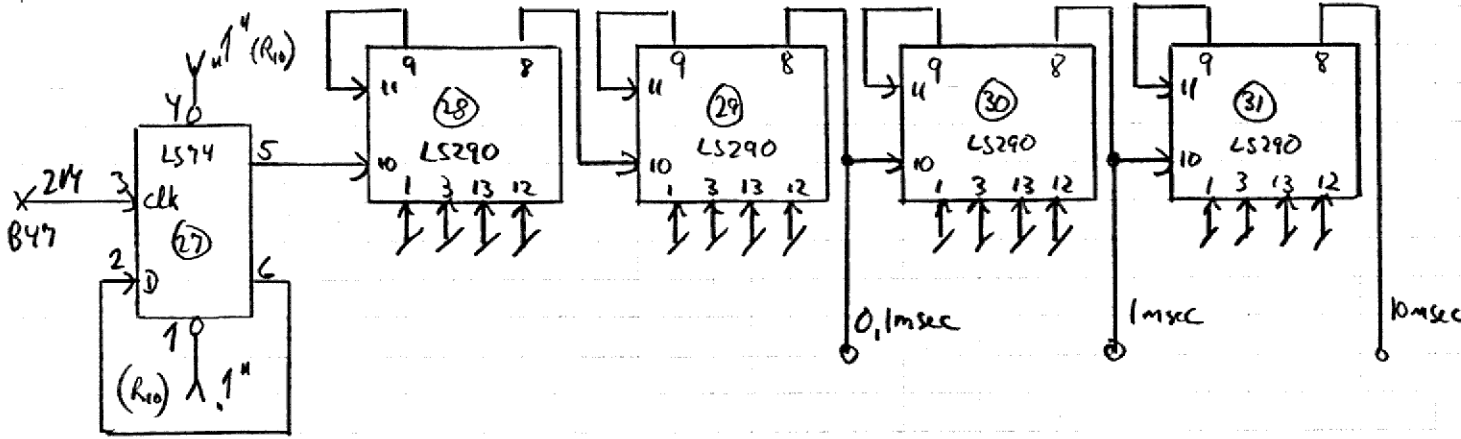

\overline{RS}

