

Qume Manual

DataTrak 5 Maintenance

August 1980

DataTrak 5 Maintenance

August 1980

Preliminary

dansk data elektronik aps

Klokkerholm
9320 Hjallerup

04423

Aalborg Universitetecenter
Institut for Elektroniske Systemer
Laboratoriet
Strandvejen 19
9000 Ålborg

TABLE OF CONTENTS

	Page
INTRODUCTION	1
SCOPE	1
DESCRIPTION	1
General Information	1
Performance Specifications	1
INTERFACE	3
ELECTRICAL INTERFACE	3
General Information	3
I/O Signal Interface	3
Input Lines	5
Head Load	5
Drive Select 0-3	5
Motor On	6
Direction Select	6
Step	6
Write Data	8
Write Gate	8
Side Select	8
Output Lines	8
Index	9
Track 00	9
Write Protect	9
Read Data	9
Ready	10
PHYSICAL INTERFACE	10
Connectors and Cables	10
I/O Signal Interface	10
DC Power	12
Terminator	13
Frame Ground	13
INSTALLATION	15
RECEIVING AND INSPECTION	15
INSTALLATION REQUIREMENTS	17
MOUNTING	18
Mechanical Dimensions	18
Recommendations	19
Proper Diskette Use	19
WARRANTY, SERVICE AND TRAINING	20
Warranty and Service	20
Training	20
CUSTOMER STRAPPABLE OPTIONS	21
GENERAL INFORMATION	21
INCORPORATION OF OPTIONS	23
Programmable Shunt	23
Head Load Option	23
Stepper Motor Power Options	23
Side Select	24

dansk data elektronik aps

Klickerholm
9620 Hjøllerup

TABLE OF CONTENTS - continued

	Page
MAINTENANCE	25
PREVENTIVE MAINTENANCE	25
MAINTENANCE TOOLS	25
ILLUSTRATED ASSEMBLIES AND PARTS LOCATIONS	25
REMOVAL AND REPLACEMENT PROCEDURES	34
Printed Circuit Board	34
Front Door Assembly	34
Front Bezel Assembly	35
In Use LED	36
Media Guides	37
Write Protect Sensor and Lamp Assembly	38
Carrier Assembly	39
Collet Assembly	40
Spindle Components	41
Index Sensor and Lamp Assemblies	43
Head Load Solenoid Assembly	44
Motor Control Board	45
Drive Motor	46
Track 00 Switch Assembly	47
Head Carriage Assembly	48
Stepper Motor	50
ADJUSTMENTS AND CHECKS	53
DRIVE MOTOR ADJUSTMENT	53
HEAD ALIGNMENT ADJUSTMENT	53
TRACK 00 SWITCH ADJUSTMENT	55
TRACK 00 STOP ADJUSTMENT	55
INDEX SENSOR ADJUSTMENT	56
AZIMUTH ALIGNMENT CHECK	57
TROUBLESHOOTING	59
GENERAL	59
DEFINITION OF DATATRAK 5 FUNCTIONAL ERRORS	59
Not Ready	59
Seek Error	59
Read Error	59
Write Error	59
No Head Load	59
TROUBLESHOOTING TECHNIQUE	59
TROUBLESHOOTING FLOWCHARTS	60
RECOMMENDED SPARE PARTS	67
FIELD LEVEL	67
DEPOT LEVEL	67
TYPICAL SCHEMATIC DIAGRAM	69
INTERCONNECTION DIAGRAM	73

LIST OF ILLUSTRATIONS

	Page
Recommended Controller Interface Circuit	3
Interface Connections	4
Step Timing	6
Control and Data Timing Requirements	7
Write Data Timing for Frequency Modulation (FM)	8
Index Timing	9
Read Data Timing	9
Interface Connection	10
Connector J1 Dimensions (component side)	10
Connector J2	13
Unpacking the Disk Drive	16
DataTrak 5 - Top View	18
DataTrak 5 - Side View	18
DataTrak 5 - Bottom View	18
Disk Drive Mounting	19
Identification of 35 and 40 Track Diskettes	19
PCB Trace/Jumper Locations	22
Stepper Motor Power Option Connections	24
Upper Unit Components	26
Mainframe Components	28
Carriage Stepper Assembly	30
Carrier, Front Bezel and Door	32
Front Door Installation	34
In Use LED Removal	35
In Use LED Installation	36
Connector Lead Removal (Typical)	36
Carrier Assembly Removal and Replacement	39
Collet Assembly Removal and Replacement	41
Spindle Components Removal and Replacement	42
Index Sensor Installation	43
Motor Control Board - Drive Motor Leads	45
Stepper Motor and Head Carriage Removal and Installation	49
"Cats-eye" Pattern	54
Track 00 Stop Adjustment	56
Index Burst Pattern	56
Azimuth Check	58
Not Ready	61
Seek Error	62
Read Error	63
Write Error	64
No Head Load	65
Typical Schematic Diagram	69
Interconnection Diagram	73

LIST OF TABLES

	Page
Performance Specifications	2
Drive Select	5
Connector P1 Requirements for a Flat Cable	11
Connector P1 Requirements for a Twisted Pair	11
I/O Signal Connector P1/J1 Pin Assignments	12
Connector P2/J2 Requirements	13
Power Connector Pin Assignments	13
Installation Requirements	17
Factory Configuration of the Option Traces and Jumpers	21
Programmable Shunt Trace Functions	23
Maintenance Tools	25
Test Equipment and Tools Required	53
Recommended Spare Parts - Field Level	67
Recommended Spare Parts - Depot Level	67

INTRODUCTION

SCOPE

This manual contains information describing the operation and maintenance of the Qume DataTrak 5 Flexible Disk Drive. This first section of the manual describes the design features and specifications. The INTERFACE section lists the physical connections of the DataTrak 5 and describes the electrical interface lines. INSTALLATION provides inspection, unpacking, and mounting information. CUSTOMER STRAPPABLE OPTIONS describes the available customer strappable options and possible configuration modifications. MAINTENANCE provides preventive maintenance information, removal and replacement procedures, adjustment instructions, and troubleshooting procedures.

DESCRIPTION

General Information

The Qume DataTrak 5 Flexible Disk Drive is a low cost direct access data storage device for 5.25 inch, two-sided flexible (floppy) diskettes. It is an advanced design that is based on Qume's manufacturing experience with the larger DataTrak 8 eight-inch version. The DataTrak 5 employs a two-sided head carriage assembly with a ceramic Read/Write (R/W) head for long media life. It also uses a field-proven, lead screw system for highly accurate and reliable head positioning. The media drive is a DC spindle drive motor. This eliminates the need for AC power to the unit. The DataTrak 5 also employs a door interlock, whereby the door cannot be closed without first properly inserting the diskette.

The DataTrak 5 weighs only three pounds (1.4 kg) and can be mounted three drives horizontally, or four drives vertically in a standard 19-inch rack and panel unit. Refer to the section on INSTALLATION for additional installation requirements.

Standard Features on the DataTrak 5 include:

- . Low heat dissipation
- . Four drive daisy chain capability
- . Internal write protect circuitry
- . In Use LED activity indicator on the front panel

The DataTrak 5 has interface compatibility with the Shugart SA450 disk drive, and complies with the American National Standards Institute (ANSI) interface specification for 5.25 inch flexible disk drives.

Performance Specifications

The DataTrak 5 provides a formatted storage capacity of 143.4K bytes on a two-sided single density flexible diskette, and 286.7K bytes on a two-sided double density flexible diskette. Refer to the table below for additional performance specifications.

SPECIFICATION SUMMARY

PERFORMANCE SPECIFICATIONS

	SINGLE DENSITY	DOUBLE DENSITY
CAPACITY PER DISKETTE		
UNFORMATTED	218.8K BYTES	437.5K BYTES
FORMATTED (16 SECTORS/TRACK)	143.4K BYTES	286.7K BYTES
RECORDING DENSITY (TRACK NO. 34)	2728 BPI	5456 BPI
TRACK DENSITY	48 TPI	48 TPI
NUMBER OF CYLINDERS	35/40	35/40
NUMBER OF TRACKS	70	70
RECORDING METHOD	FM	MFM
ROTATIONAL SPEED	300 RPM	300 RPM
TRANSFER RATE	125K bits/sec	250K bits/sec
LATENCY (AVERAGE)	100 ms	100 ms
ACCESS TIME		
AVERAGE	241 ms	241 ms
TRACK TO TRACK	20 ms	20 ms
SETTLING	15 ms	15 ms
HEAD LOAD TIME	50 ms typ.	50 ms typ.
MOTOR START TIME	1 sec typ.	1 sec typ.

INTERFACE

ELECTRICAL INTERFACE

General Information

The DataTrak 5 has two interface connectors. Connector P1/J1 interfaces data signals, and connector P2/J2 interfaces the +5V and +12V DC power sources. The interface connections are shown in the illustration on the following page.

I/O Signal Interface

All the I/O signal interface lines are TTL compatible and are active (true) when low. The disk drive uses 7438 NAND buffers (open collector) as output line drivers, and TTL logic level receivers on the input lines. The input of all receiver lines in a single drive, and those in the last drive of a daisy chain, must be terminated in 150 ohms pulled up to +5 volts (refer to the Terminator paragraph). The illustration below shows the recommended controller interface circuit.

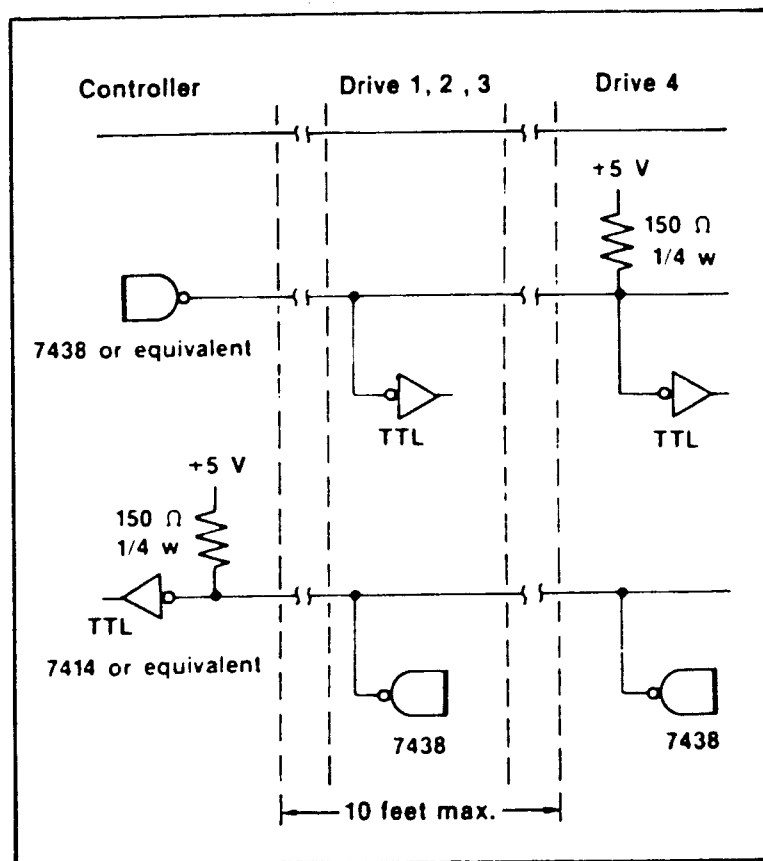

Recommended Controller Interface Circuit

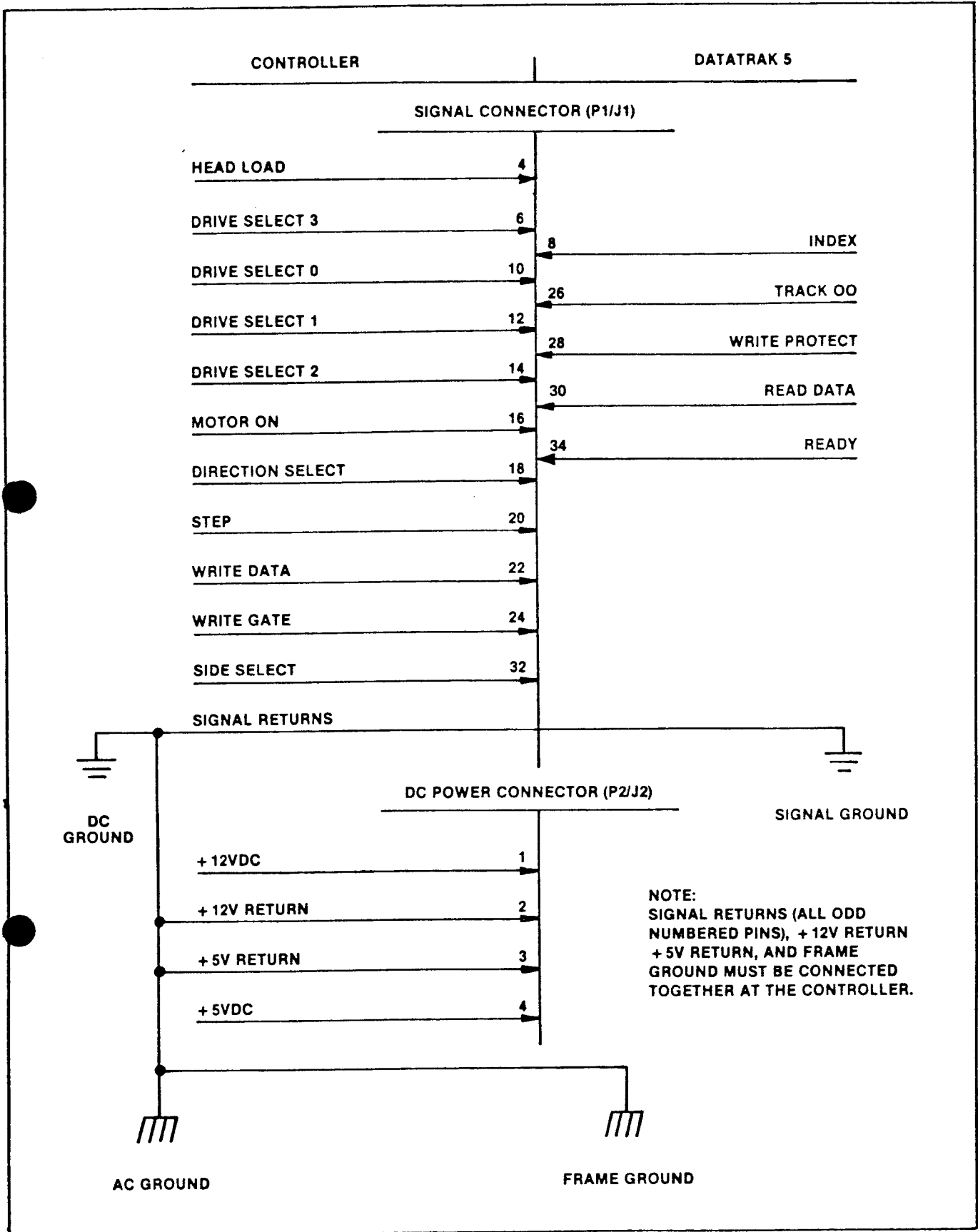

Interface Connections

Input Lines

There are eleven active low TTL input lines. The low (true) voltage level for the lines is 0 to 0.4 volts. The high (false) voltage level is 2.4 to 5.25 volts. The characteristics of the individual input lines are described below.

Head Load

An active low level on this line (pin 4) loads the R/W heads against the diskette. In some applications HEAD LOAD is a Customer Strappable Option.

Drive Select 0-3

An active low level on this line (pin 6, 10, 12, or 14) enables communication between an individual drive and the controller.

The DataTrak 5 is configured from the factory to operate in a single drive system. However, it can be modified by the customer to operate in a multiple drive system. Four separate input lines are provided for the using system to select which drive on the interface is to be used. When two, three, or four, drives are daisy chained, each drive must have a unique DRIVE SELECT address. The DRIVE SELECT address is controlled by a programmable shunt. When trace DS0 (on the programmable shunt) is shorted, the drive will be activated by an active low signal on the DRIVE SELECT 0 line. If trace DS1 is shorted, the drive will be activated when the DRIVE SELECT 1 line is active low. The same system applies to traces DS2 and DS3. Refer to the Drive Select table below.

NOTE

Only one trace can be shorted within a single drive. Each drive within a daisy chain must have a unique DRIVE SELECT number.

Drive Select

Drive Number	Drive Select Input				Programmable Shunt			
	0	1	2	3	DS0	DS1	DS2	DS3
0	L	H	H	H	S	0	0	0
1	H	L	H	H	0	S	0	0
2	H	H	L	H	0	0	S	0
3	H	H	H	L	0	0	0	S

L = low level
H = high level

S = short
0 = open

NOTE

When DS0-DS3 are not desired, an Optional Drive Select can be used by shorting the MX trace on the programmable shunt. The HM trace must then also be shorted to activate the head load solenoid when the MOTOR ON signal is true.

Motor On

An active low level on this line (pin 16) enables the drive motor. The spindle takes one second after MOTOR ON is activated to come up to speed before reading or writing on the diskette. This line should be deactivated for maximum motor life, if no commands are to be issued to the drive within two seconds (10 media revolutions) after completion of a previous command.

Direction Select

DIRECTION SELECT (pin 18) defines the direction of R/W head movement when the STEP line is pulsed. A low level on this line causes the head positioning mechanism to move the R/W head toward the center of the diskette. With the DIRECTION SELECT line at a high level, a pulse on the STEP line causes the head positioning mechanism to move the R/W head away from the center of the diskette. The logic state of DIRECTION SELECT can be changed at any time after the trailing (positive going) edge of the STEP pulse, and to within one microsecond before the trailing edge of a following STEP pulse. The logic state of DIRECTION SELECT cannot be changed during the positive going transition of STEP, or within the preceding one microsecond of the positive going transition of STEP.

Step

An active low pulse on this line (pin 20) will cause the R/W head to be moved one track. The direction of movement is controlled by the DIRECTION SELECT line. Pulses applied to the STEP line have the timing characteristics shown below.

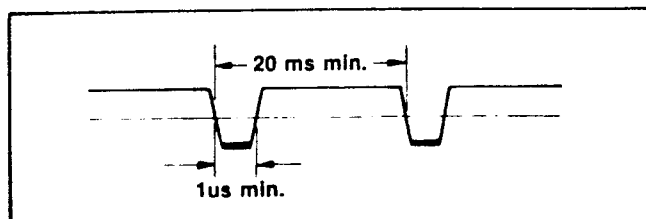

Step Timing

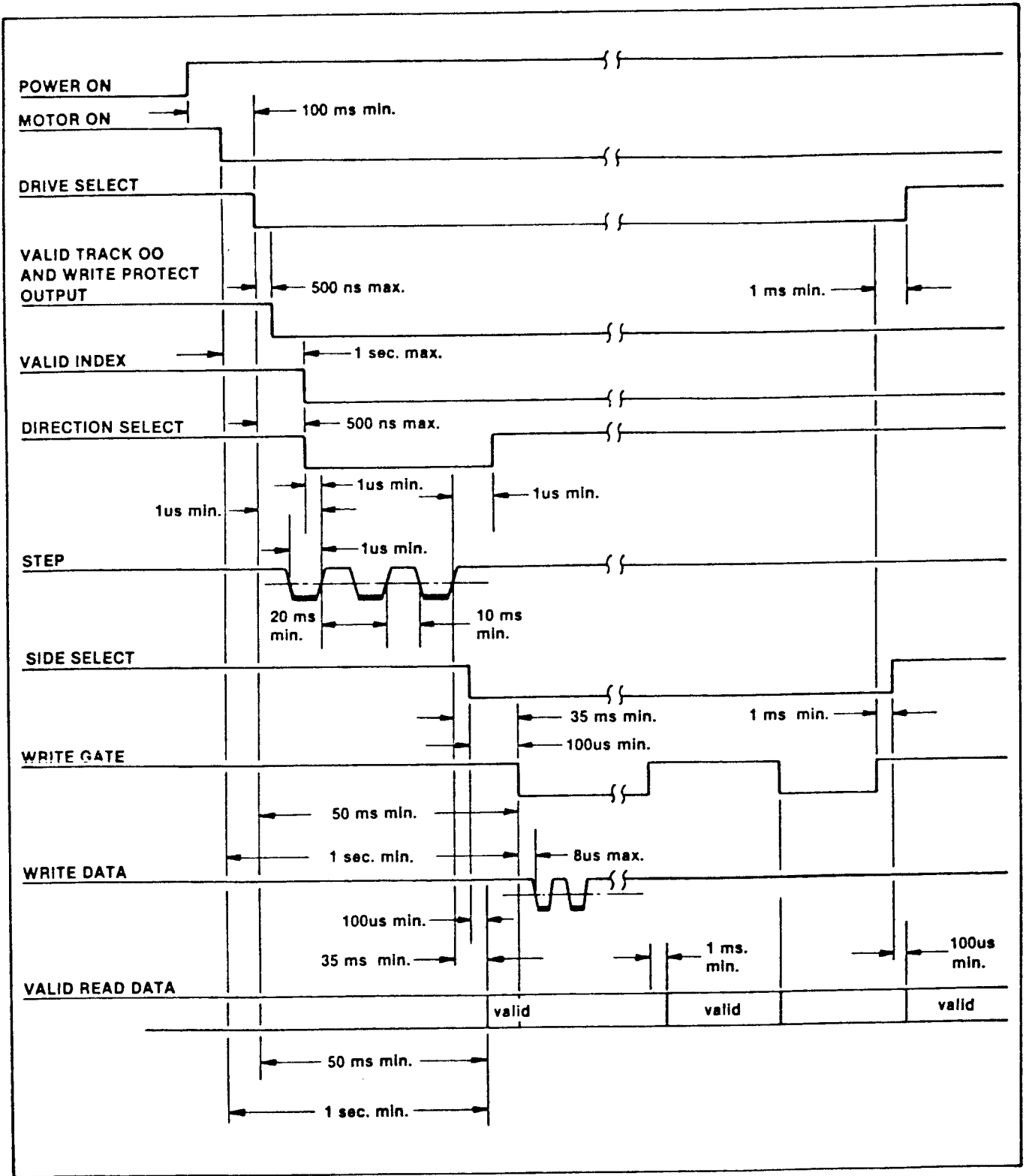

Control and Data Timing Requirements

Write Data

This interface line (pin 22) provides the data to be written on the diskette. Each transition from a high level to an active low level causes the write current polarity through the head to be reversed. The timing characteristics for the WRITE DATA Frequency Modulation (FM) format are shown below.

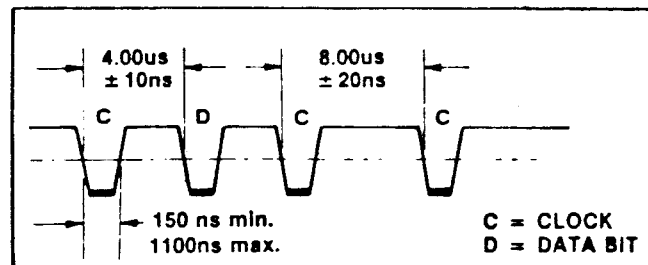

Write Data Timing for Frequency Modulation (FM)

Write Gate

An active low level on this line (pin 24) enables the write current source and disables the stepping (head positioning) circuitry. A high level on this line enables the read circuitry. Deactivation of DRIVE SELECT, and/or changing SIDE SELECT must be delayed at least one millisecond following a write operation to assure that the track is fully tunnel erased.

Refer to the Control and Data Timing Requirements illustration for the timing relationships.

Side Select

SIDE SELECT defines which surface of a two-sided diskette is to be accessed for data recording or retrieval. An active low level on this line (pin 32) selects the R/W head for side 1 of the diskette (the diskette surface that faces the PCB); a high level selects the R/W head for side 0 of the diskette (the diskette surface that faces the main frame). When switching from side to side a 100 microsecond delay is required before any read or write operation can be initiated.

Output Lines

There are five active low TTL output lines. The low (true) voltage level is 0 to 0.4 volt, with a maximum sink of 48 milliamps when the 7438 NAND buffers draw current. The high (false) voltage level is 2.4 to 5.25 volts, with a maximum leakage current of 250 microamps when the 7438 NAND buffers are at cutoff. The characteristics of the individual output lines are described below.

Index

This interface signal (pin 8) is provided by the drive once each revolution. The leading (negative going) edge of the INDEX pulse indicates to the controller the beginning of the next track. The timing characteristics for INDEX are shown below.

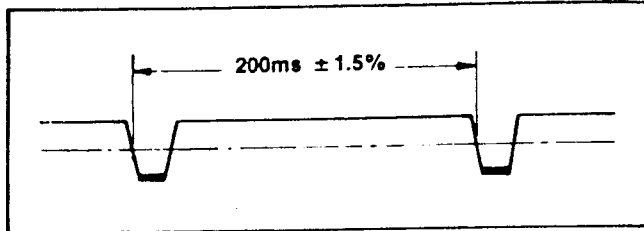

Index Timing

Track 00

An active low level on this line (pin 26) indicates that the R/W head is positioned at Track 00.

Write Protect

An active low level on this line (pin 28) indicates that a diskette with a disable tab covering the write enable notch is installed. Under normal operation, the drive will inhibit writing when a protected diskette is installed.

Read Data

Data from the diskette is output to the host system in the same form as it was received on the WRITE DATA line. Each flux reversal that is sensed on the diskette produces an active low pulse on the READ DATA line (pin 30), and a return to high level one microsecond later. The timing characteristics for READ DATA are shown below.

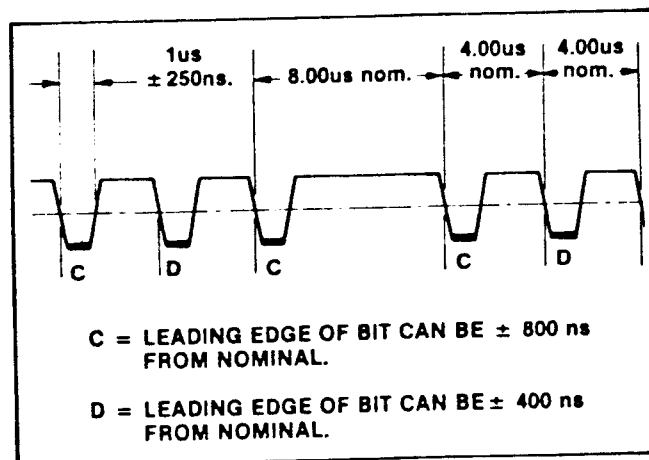

Read Data Timing

Ready

An active low level on this line (pin 34) indicates that the drive is ready to read or write data.

PHYSICAL INTERFACE

Connectors and Cables

The physical interface between the DataTrak 5 and the host system is made through two connectors: digital I/O signals on P1/J1, and DC power on P2/J2. The illustration below shows how four disk drives would be connected to the host system (drives #2 and #3 have been deleted for clarity). Refer to the ELECTRICAL INTERFACE section for specific pin connections.

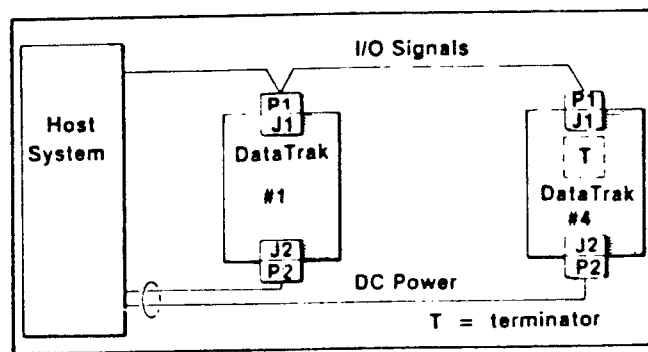

Interface Connection

I/O Signal Interface

All I/O signals are interfaced through connector P1/J1. Connection to J1 is through a 34-pin PCB edge card connector. The dimensions for this connector are shown in the illustration below.

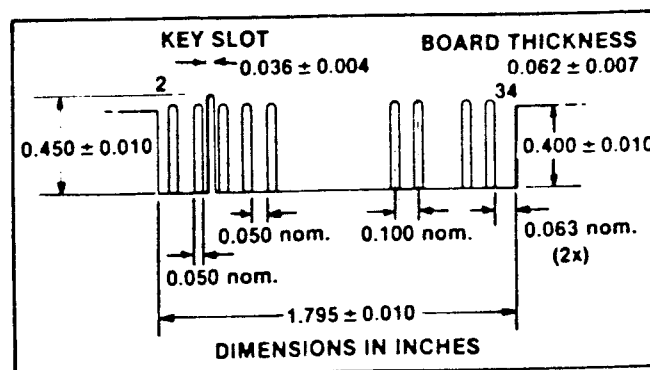

Connector J1 Dimensions (component side)

Connector P1 can be for a flat cable or a twisted pair. The two tables below list the respective requirements.

Connector P1 Requirements for a Flat Cable

PARTS		3M P/N
CONNECTOR		3463-0001
POLARIZING KEY		3439-0000
CRIMP TOOL	PRESS	3440
	LOCATOR PLATE	3443-11
	PLATEN	3442-1
FLAT CABLE (10 FEET MAX.)		3365-34

Connector P1 Requirements for a Twisted Pair

PARTS	CRIMP TYPE	SOLDER TYPE
	AMP P/N	AMP P/N
HOUSING	583717-5	583717-5
CONTACT	1-583616-1	583854-3
POLARIZING KEY	583274-1	583274-1
CRIMP TOOL	90268-1	-
EXTRACTOR TOOL	91073-1	91073-1
TWISTED PAIR (10 FEET MAX.)	AWG 26	AWG 26

The table below lists the I/O signal connector pin assignments.

I/O Signal Connector P1/J1 Pin Assignments

SIGNAL RETURN	SIGNAL	SIGNAL NAME
PIN NO.	PIN NO.	STANDARD
1	2	RESERVED
3	4	HEAD LOAD
5	6	DRIVE SELECT 3
7	8	INDEX
9	10	DRIVE SELECT 0
11	12	DRIVE SELECT 1
13	14	DRIVE SELECT 2
15	16	MOTOR ON
17	18	DIRECTION SELECT
19	20	STEP
21	22	WRITE DATA
23	24	WRITE GATE
25	26	TRACK 00
27	28	WRITE PROTECT
29	30	READ DATA
31	32	SIDE SELECT
33	34	READY

DC Power

DC Power is supplied through connector P2/J2. The two tables below list the cable requirements and connector pin assignments.

Connector P2/J2 Requirements

PARTS	P2 (CABLE SIDE) AMP P/N	J2 (DRIVE SIDE) AMP P/N
HOUSING	1-480424-0	1-480426-0
CONTACT (4 PINS)	60619-1	---
CRIMP TOOL	90124-2	---
EXTRACTOR TOOL	1-305183-2	---
CABLE (10 FEET MAX.)	AWG 18	---

Power Connector Pin Assignments

PIN NO.	SIGNAL NAME
1	+12 VDC
2	+12 V RETURN
3	+5 V RETURN
4	+5 VDC

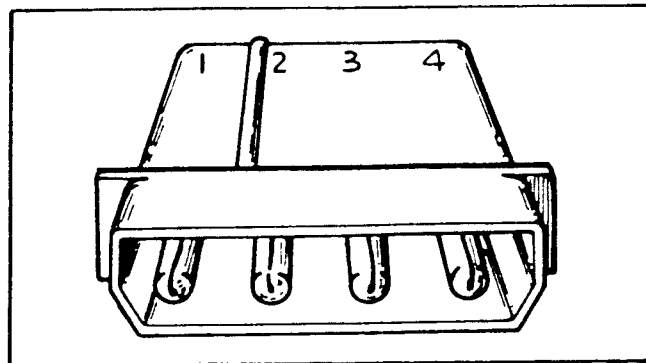

Connector J2

Terminator

The terminator is a DIP resistor module which must be plugged into the DIP socket on the PCB of a single drive, or into the last drive of a daisy chain. No other drives in a daisy chain should have terminator resistors installed.

Frame Ground

The DataTrak 5 must be grounded to the controller to insure proper operation and low noise susceptibility. The system frame ground wire should be connected to the disk drive frame. A fast-on tab is provided on the drive for this purpose.

Fast-on Tab	Mating Connector
AMP P/N 61664-1	AMP P/N 60972-1

INSTALLATION

RECEIVING AND INSPECTION

Each disk drive is shipped in an individual container with a protective, preformed foam liner. The drive is also wrapped in a plastic bag to prevent dust contamination of the R/W heads.

Unpack and inspect the disk drive as follows (refer to the illustration on the following page):

1. Inspect the container for external signs of damage. If any damage is observed, have the delivery agent note the damage on the shipping document. Some shippers may wish to be present when the container is opened if external damage is apparent.
2. Open the container and remove the drive from its cradled position in the foam liner. Lift the drive from the bottom, up and out of the container.
3. Remove the drive from the plastic bag.
4. Open the drive door and remove the cardboard shipping insert.

CAUTION

The R/W heads must not be allowed to come together without a diskette, a clean piece of paper, or the cardboard shipping insert installed between the head surfaces.

5. Retain all packing materials for possible reshipment. Always install the cardboard insert between the heads should reshipment be necessary.
6. Inspect the drive for scratches, dents, loose components, and other obvious damage. Note any evidence of such damage on the invoice and file a claim with the carrier immediately, if the condition of the unit so warrants.
7. If damage that might impair drive operation is detected, do not attempt to operate the disk drive. Contact Qume for advice and instructions.
8. Refer to these instructions when repacking the drive.

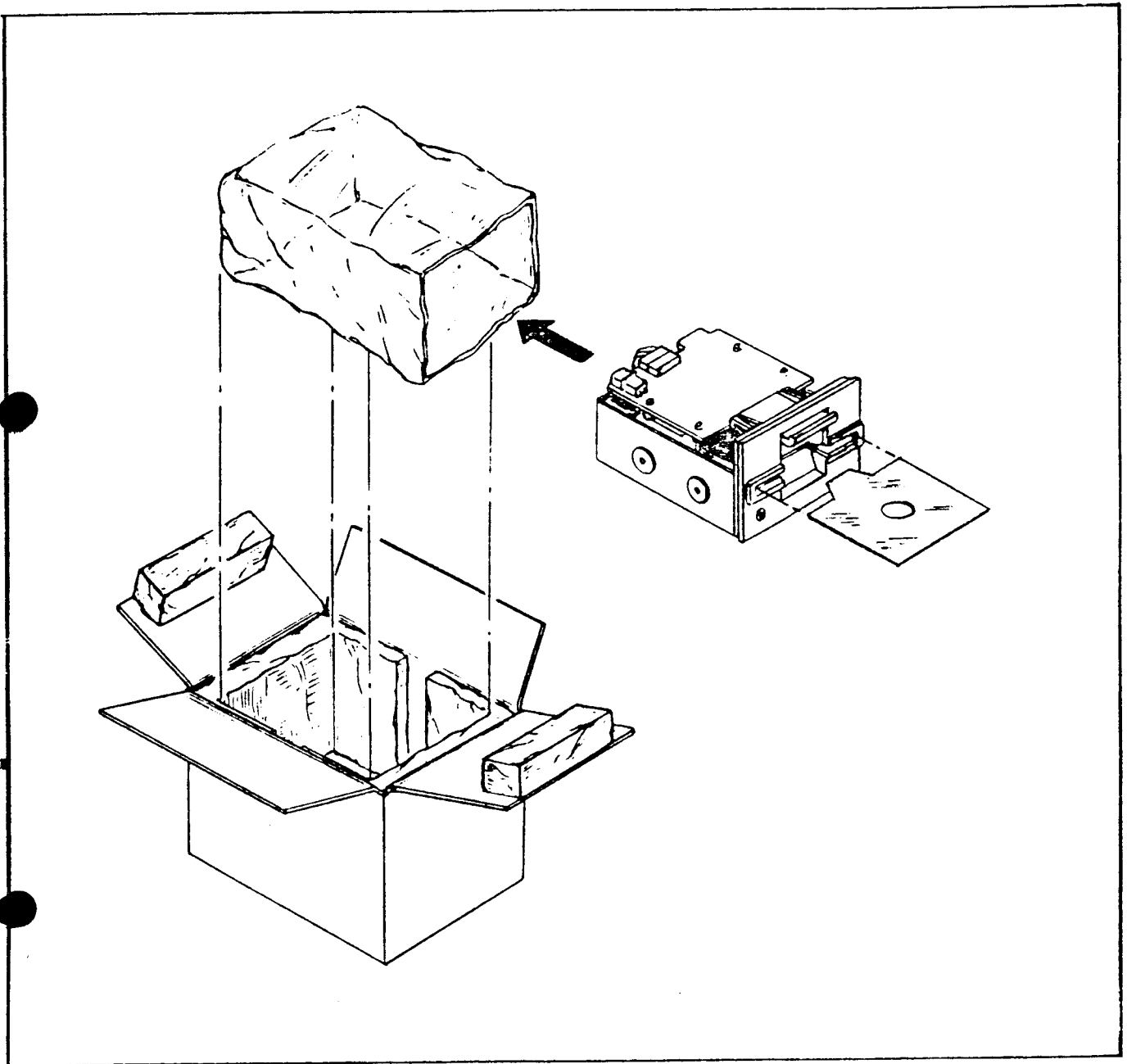

Unpacking the Disk Drive

INSTALLATION REQUIREMENTS

The DataTrak 5 has certain power, environmental, and mechanical requirements. Review the table below before installing the disk drive.

Installation Requirements

DC POWER REQUIREMENTS	VOLTAGE	MAX. RIPPLE	CURRENT
	+12 VDC _{+5%}	0.1 V (P-P)	1.35 A TYPICAL
	+5 VDC _{+5%}	0.05 V (P-P)	0.5 A TYPICAL
POWER DISSIPATION	CONTINUOUS 18.7 W TYPICAL (64 BTU/HR) STAND BY 7.5 W TYPICAL (25 BTU/HR)		
ENVIRONMENT	TEMPERATURE	OPERATING	STORAGE
		5° C to 43° C (41° F TO 110° F)	-10° C to 45° C (14° F TO 113° F)
	RELATIVE HUMIDITY	20 TO 80% RH	8 TO 80% RH
	MAX. WET BULB	29° C (84° F)	NO CONDENSATION
MECHANICAL	WIDTH	146 mm (5.75 in.)	
	HEIGHT	82.6 mm (3.25 in.)	
	DEPTH	203.2 mm (8.0 in.)	
	WEIGHT	1.4 Kg (3 lbs.)	
MOUNTING POSITIONS	HORIZONTAL FRONT LOAD (PCB SIDE UP ONLY) VERTICAL FRONT LOAD VERTICAL TOP LOAD		

MOUNTING

Mechanical Dimensions

Shown below are the top, bottom, and side views of the DataTrak 5. The mounting and clearance dimensions (shown in inches) should be reviewed before installation.

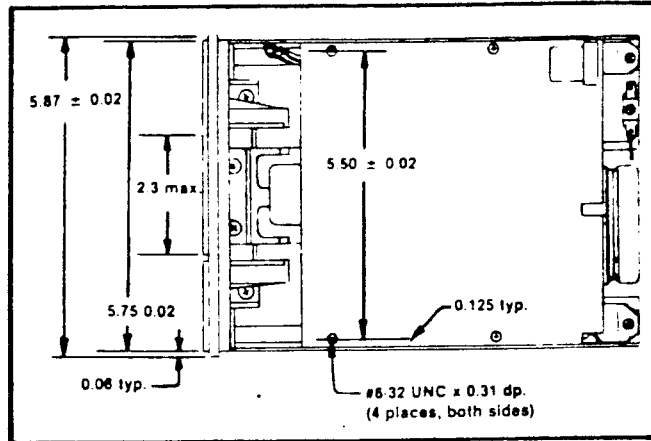

DataTrak 5 - Top View

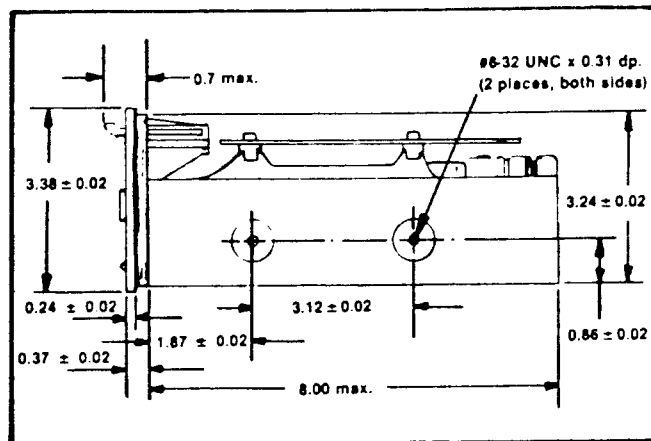

DataTrak 5 - Side View

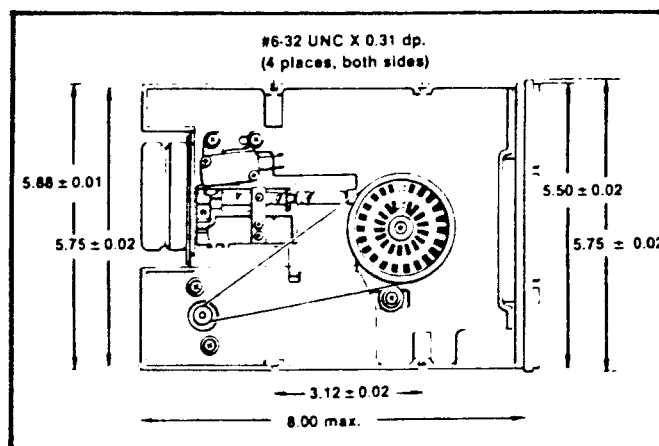

DataTrak 5 - Bottom View

Recommendations

The DataTrak 5 can be mounted in any plane: horizontally for front loading, vertically for front loading, or vertically for top loading. However, when the disk drive is mounted in a horizontal, front loading position, it must be situated such that the door opens upward and the In Use LED on the front bezel is below the door (refer to the illustration below).

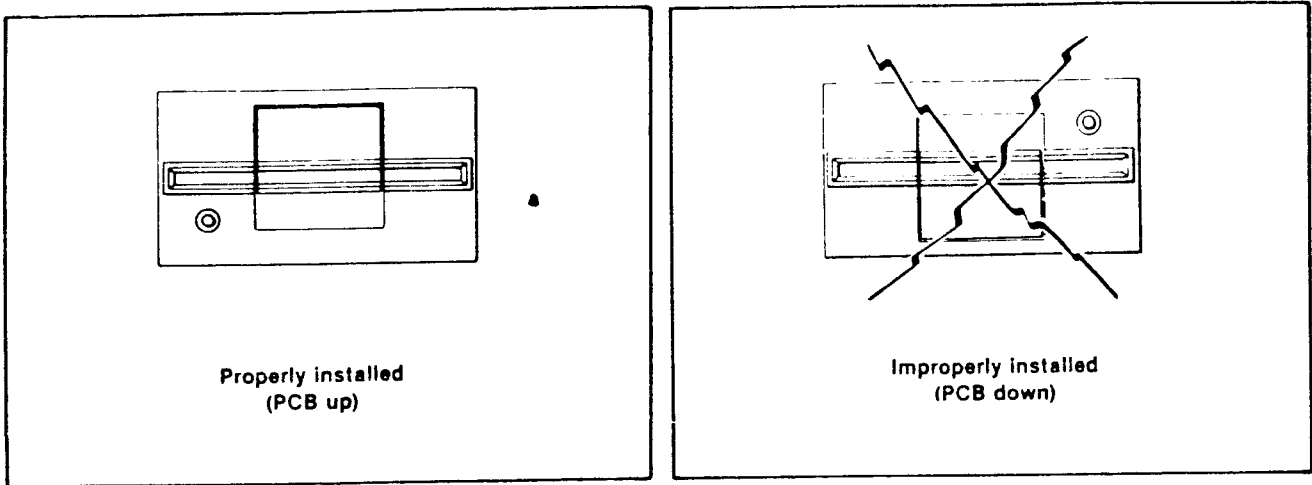

Disk Drive Mounting

Proper Diskette Use

Verify that the proper diskette is used in the DataTrak 5. Reserve the use of 35 track diskettes for drives of 35 track capability, and 40 track diskettes for drives of 40 track capability. Do not attempt to use a 35 track diskette in a drive intended for 40 track diskettes. To do so may cause R/W head damage.

The two kinds of diskettes used in the DataTrak 5 (35 or 40 track), can be easily differentiated by noting the measurement between the collet access hole and the head access slot in the diskette jacket (refer to the illustration below).

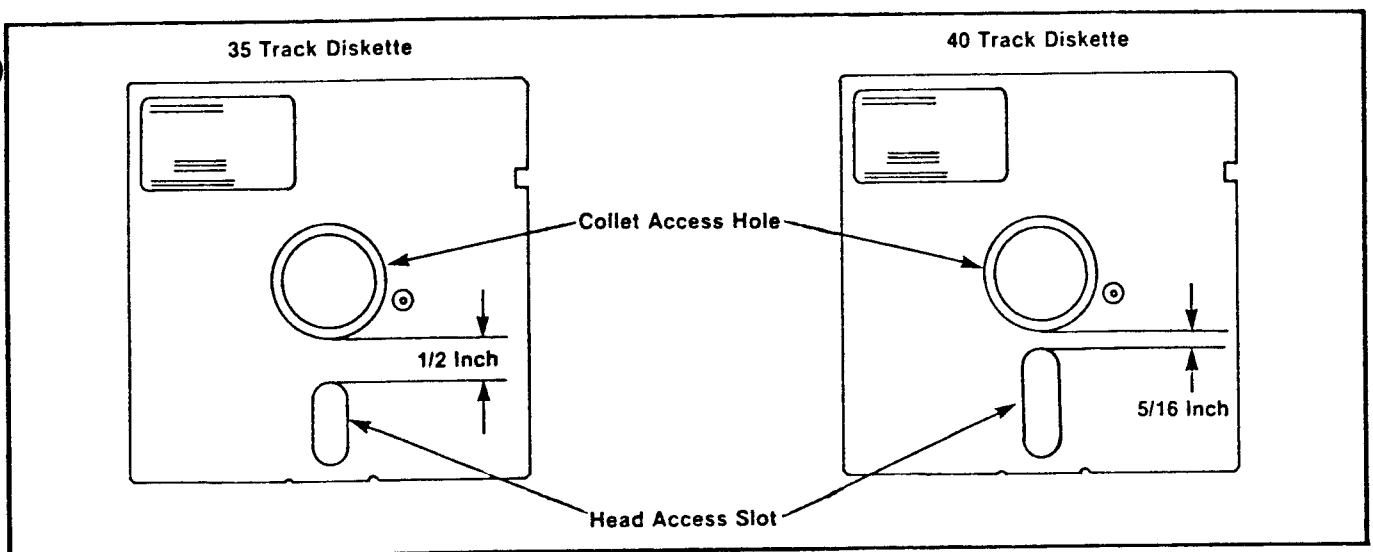

Identification of 35 and 40 Track Diskettes

WARRANTY, SERVICE AND TRAINING

Warranty and Service

The basic Qume service policy, terms, conditions and prices for repairs are specifically described in the Memory Products Service and Spares Catalog, publication number 30036. For specific warranty details refer to your Qume DataTrak 5 purchase contract.

Training

Qume offers depot service training on the DataTrak 5 Disk Drive. These regularly scheduled classes, held at Qume's San Jose, California facility, cover mechanical and electronic theory of operation, field and depot service level troubleshooting, subassembly removal and replacement procedures, mechanical and electronic adjustments and service checks, and preventive maintenance. Detailed information on customer training classes is contained in the Memory Products Service and Spares Catalog, publication number 30036.

CUSTOMER STRAPPABLE OPTIONS

GENERAL INFORMATION

The DataTrak 5 can be modified by the user to alter some of the functions that were described in the INTERFACE section. These modifications are made by adding or deleting jumpers on the programmable shunt, side select trace pads, and/or stepper power pins. The table below shows the configuration of the option traces and jumpers as shipped from the factory. The illustration on the next page shows their location on the disk drive PCB.

Factory Configuration of the Option Traces and Jumpers

TRACE/JUMPER DESIGNATOR	DESCRIPTION	FROM FACTORY	
		OPEN	SHORT
DS0	DRIVE SELECT ADDRESS (PIN 10)		X
DS1	DRIVE SELECT ADDRESS (PIN 12)		X
DS2	DRIVE SELECT ADDRESS (PIN 14)		X
DS3	DRIVE SELECT ADDRESS (PIN 6)		X
HS	HEAD LOAD FROM DRIVE SELECT SIGNAL		X
MX	OPTIONAL DRIVE SELECT		X
HM	HEAD LOAD FROM MOTOR ON SIGNAL	X	
P-M	STEPPER MOTOR POWER FROM MOTOR ON SIGNAL		X
P-S	STEPPER MOTOR POWER FROM DRIVE SELECT SIGNAL	X	
A, B1, B3	SIDE SELECT FOR DOUBLE-SIDED DRIVES FROM DRIVE SELECT SIGNAL	X	
HL	HEAD LOAD		X

NOTE

When shipped from the factory, pin P is normally jumpered to pin M in order to supply DC power to the stepper motor.

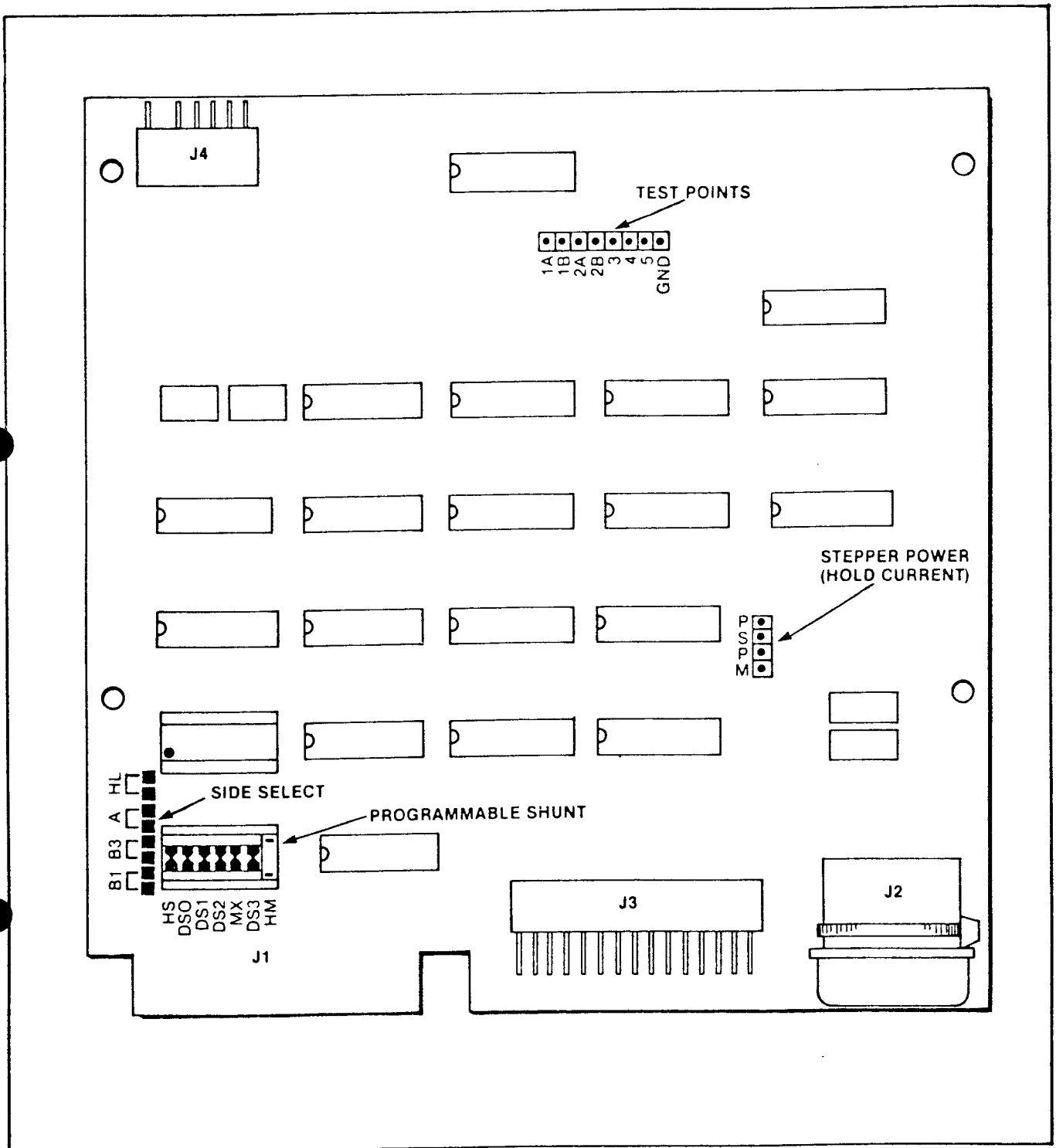

PCB Trace/Jumper Locations

INCORPORATION OF OPTIONS

Programmable Shunt

A 14-pin programmable shunt is provided for the seven commonly used trace-cut options. All of these traces, except trace HM, are normally shorted when shipped from the factory. The shorted and open functions of the pluggable options are shown in the table below.

Programmable Shunt Trace Functions

TRACE	FUNCTION - NORMALLY SHORTED	FUNCTION - OPEN
HS	HEAD LOAD FROM DRIVE SELECT	HEAD LOAD NOT CONTROLLED BY DRIVE SELECT
DS0	DRIVE SELECTED WHEN PIN 10 IS ACTIVE	DRIVE NOT SELECTED WHEN PIN 10 IS ACTIVE
DS1	DRIVE SELECTED WHEN PIN 12 IS ACTIVE	DRIVE NOT SELECTED WHEN PIN 12 IS ACTIVE
DS2	DRIVE SELECTED WHEN PIN 14 IS ACTIVE	DRIVE NOT SELECTED WHEN PIN 14 IS ACTIVE
MX	DRIVE WILL BE SELECTED INDEPENDENT OF DSO-DS3	DRIVE SELECT WILL BE ALLOWED FROM DSO-DS3
DS3	DRIVE SELECTED WHEN PIN 6 IS ACTIVE	DRIVE NOT SELECTED WHEN PIN 6 IS ACTIVE
HM*	HEAD LOAD FROM MOTOR ON SIGNAL	HEAD LOAD NOT CONTROLLED BY MOTOR ON SIGNAL

* NORMALLY OPEN WHEN SHIPPED FROM FACTORY.

Head Load Option

When shipped from the factory, trace HS is shorted on the programmable shunt. This allows the R/W head to be loaded against the diskette when any DRIVE SELECT signal (DS0-DS3) is activated. There is one other option available.

Option. Trace HM shorted; trace HS open. This allows the R/W head to be loaded against the diskette when the MOTOR ON signal is activated.

Stepper Motor Power Options (refer to the illustration below)

When shipped from the factory, pin P is jumpered to pin M. This arrangement supplies DC power to the stepper motor when the MOTOR ON signal is activated. Two other options are available.

Option 1. Pins P and S jumpered; pins P and M open. This arrangement supplies power to the stepper motor when any DRIVE SELECT signal (DS0-DS3) is activated.

Option 2. No jumpers installed. This arrangement supplies power to the stepper motor whenever the drive is powered-up.

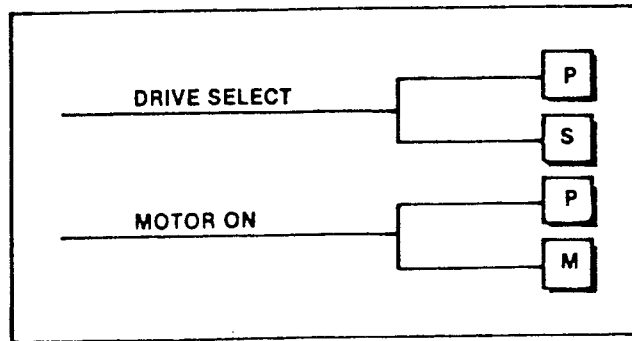

Stepper Motor Power Option Connections

Side Select

This option uses existing DRIVE SELECT lines (DS1 and DS3) to address one or two disk drives. A low or high level signal, applied to a particular DRIVE SELECT line will select side 1 or 0 respectively.

Installation (refer to the PCB Trace/Jumper Locations illustration)

For one drive:

1. Open trace DS1 on the programmable shunt with a small screwdriver.
2. Short traces B1 and A.

For two drives:

1. Open trace DS3 on the programmable shunt with a small screwdriver.
2. Short traces B3 and A (if trace A has not already been shorted).

MAINTENANCE

PREVENTIVE MAINTENANCE

Under normal conditions the DataTrak 5 does not require periodic adjustment. However, cleanliness is extremely important to the proper care of the disk drive. Always look for dirt and corrosion, as well as wear, binds, and loose connections.

CAUTION

The head/carriage is a factory adjusted and tested assembly. Do not try to repair this internal component. Do not, for any reason, clean the read/write heads. This will cause severe damage to the head surfaces or head spring supports.

Keep the disk drive as free from dirt as possible. Place the unit in a clean plastic bag or sealable box for storage. Occasionally, dirt may build up on the shafts of the stepper motor assembly. Remove the dirt with a clean, lint-free cloth. The entire drive should be cleaned every six months. Always use a clean, lint-free cloth.

A general service check should be made on the DataTrak 5 every 3000 power-on hours or 12 months. The servicing of each assembly is described in the following section. During the service check inspect the main frame for loose connectors, switches, and other components. Secure all loose parts. Inspect the drive belt for frayed or weakened areas. Replace the belt if it is damaged.

MAINTENANCE TOOLS

The tools listed in the table below are required for general maintenance of the DataTrak 5. These tools are available at most hardware stores.

MAINTENANCE TOOLS

TOOL	SIZE (LENGTH)
PHILLIPS SCREWDRIVER (2)	#1 HEAD, 4 INCH SHANK; #2 HEAD, 4 INCH SHANK
TWEEZERS	4 TO 6 INCHES (NEEDLE POINT)
ALLEN WRENCH	1.5mm
FLAT HEAD SCREWDRIVER	4 INCH SHANK
SOLDERING EQUIPMENT	
CE DISKETTE	Q.P.N. 51197-01

ILLUSTRATED ASSEMBLIES AND PARTS LOCATIONS

The following pages show the location of various disk drive components that are described in the REMOVAL AND REPLACEMENT PROCEDURES. It is recommended that the technician become familiar with these components and their location before continuing further into the MAINTENANCE section.

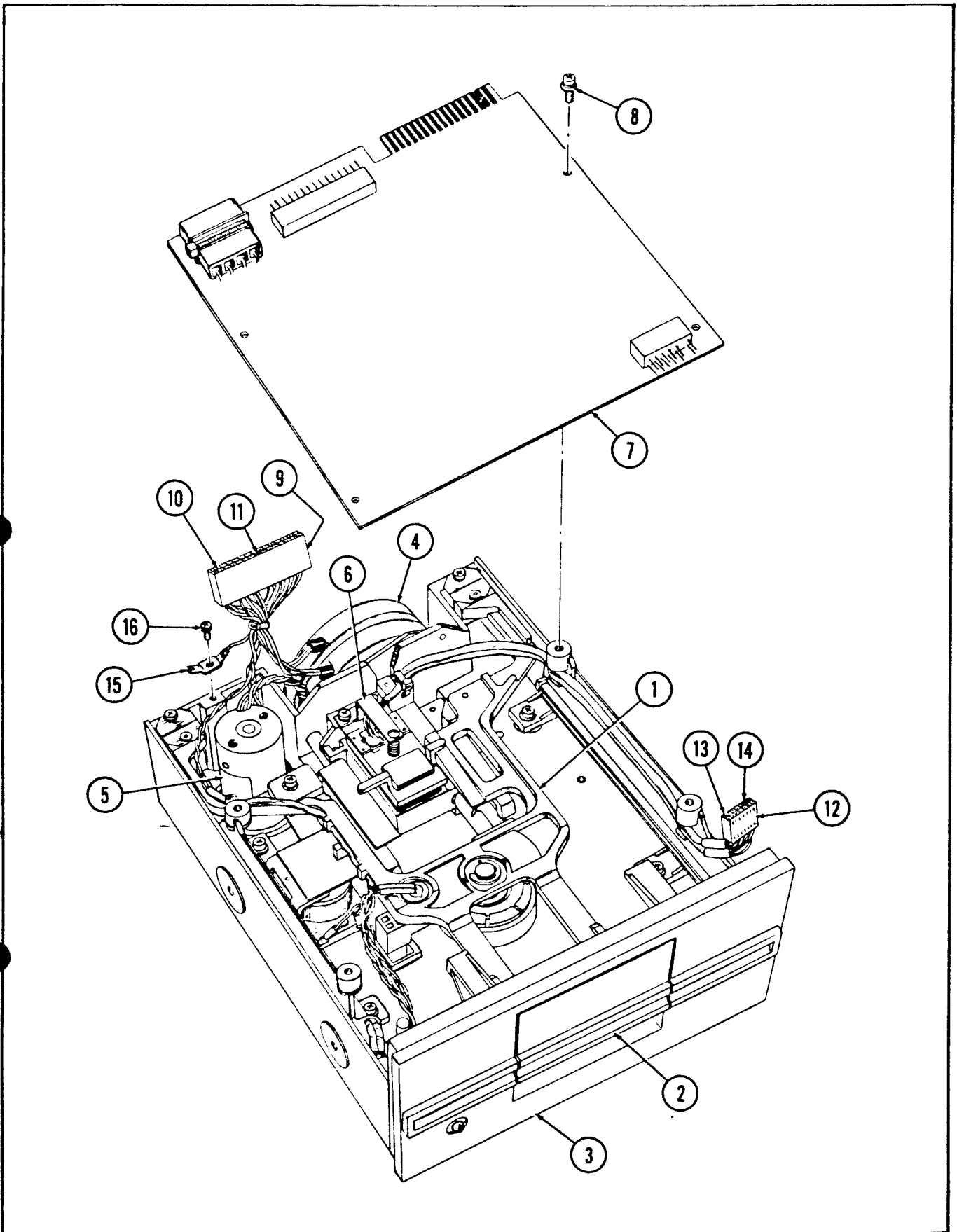

Upper Unit Components

DataTrak 5 Upper Unit Components 51000-01

- (1) 51054-01 Carrier Assembly
- (2) 51104-01 Front Door Assembly
- (3) 51115-01 Front Bezel Assembly
- (4) 51126-01 Stepper Motor Assembly
- (5) 51079-01 Drive Motor
- (6) 51017-01 Carriage Assembly
- (7) 51004-01 Printed Circuit Board
- (8) 55173-06 Screw, 3mm w/lock & flat washer, 6mm long
- (9) 55080-30 J3 Connector Housing
- (10) 55060-02 Contact for 55080-30 (requires one for each wire)
- (11) 55070-01 Polarizing Key for 55080-30
- (12) 55084-14 J4 Connector Housing
- (13) 55060-01 Contact for 55084-14 (requires one for each wire)
- (14) 55070-01 Polarizing Key for 55084-14
- (15) 51152-01 Ground Terminal Assembly
- (16) 55163-06 Screw 3mm w/lock & flat washer, 6mm long

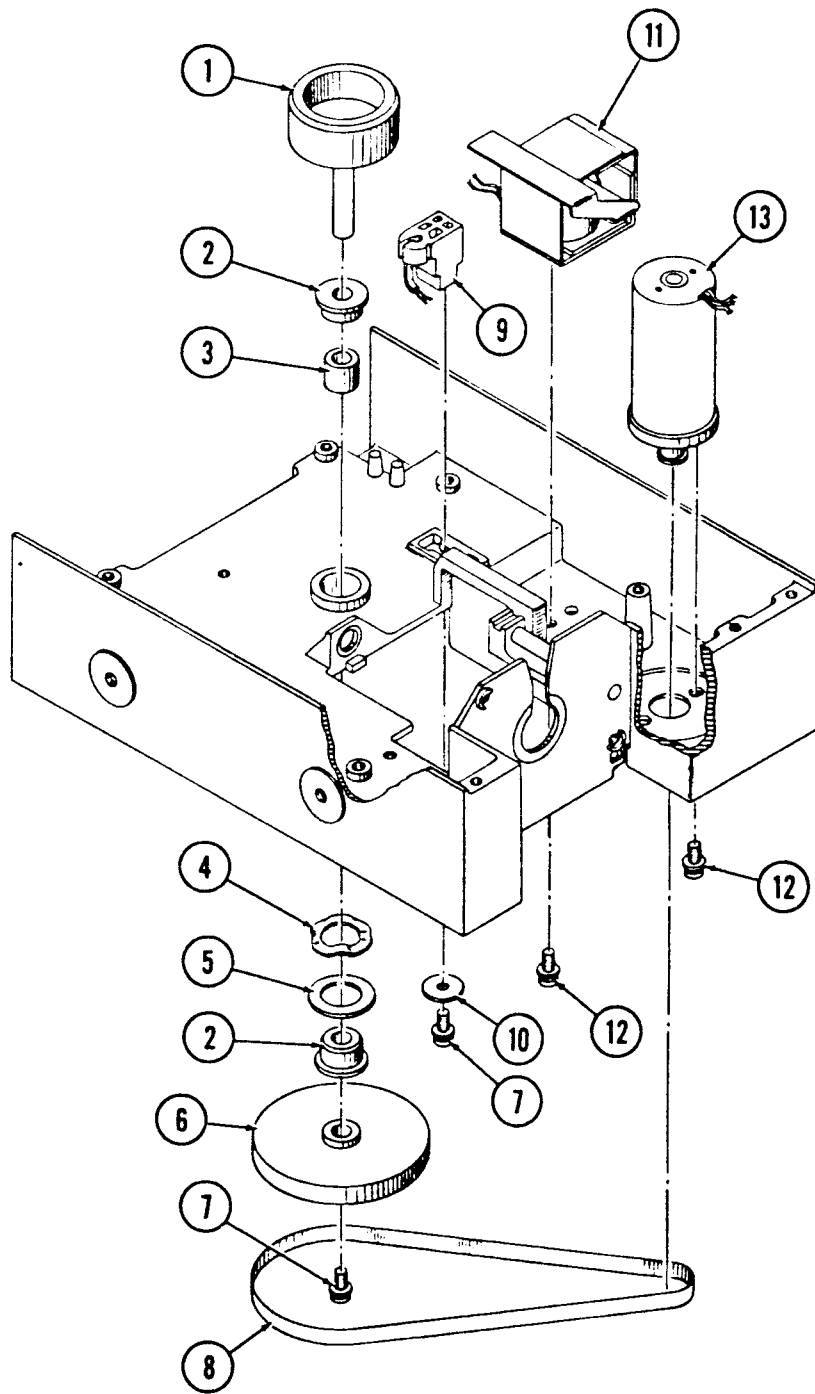

Mainframe Components

DataTrak 5 Mainframe Components

- (1) 51099-01 Spindle Hub
- (2) 51074-15 Bearing
- (3) 51101-01 Collar
- (4) 51102-01 Wave Washer
- (5) 51098-01 Spindle Washer
- (6) 51094-01 Spindle Pulley Assembly
- (7) 55173-08 Screw, 3mm w/lock & flat washer, 8mm long
- (8) 51086-01 Drive Belt
- (9) 51083-01 Index Sensor Assembly
- (10) 55210-04 Washer
- (11) 51087-01 Head Load Solenoid Assembly
- (12) 55173-06 Screw, 3mm w/lock and flat washer, 6mm long
- (13) 51079-01 Drive Motor

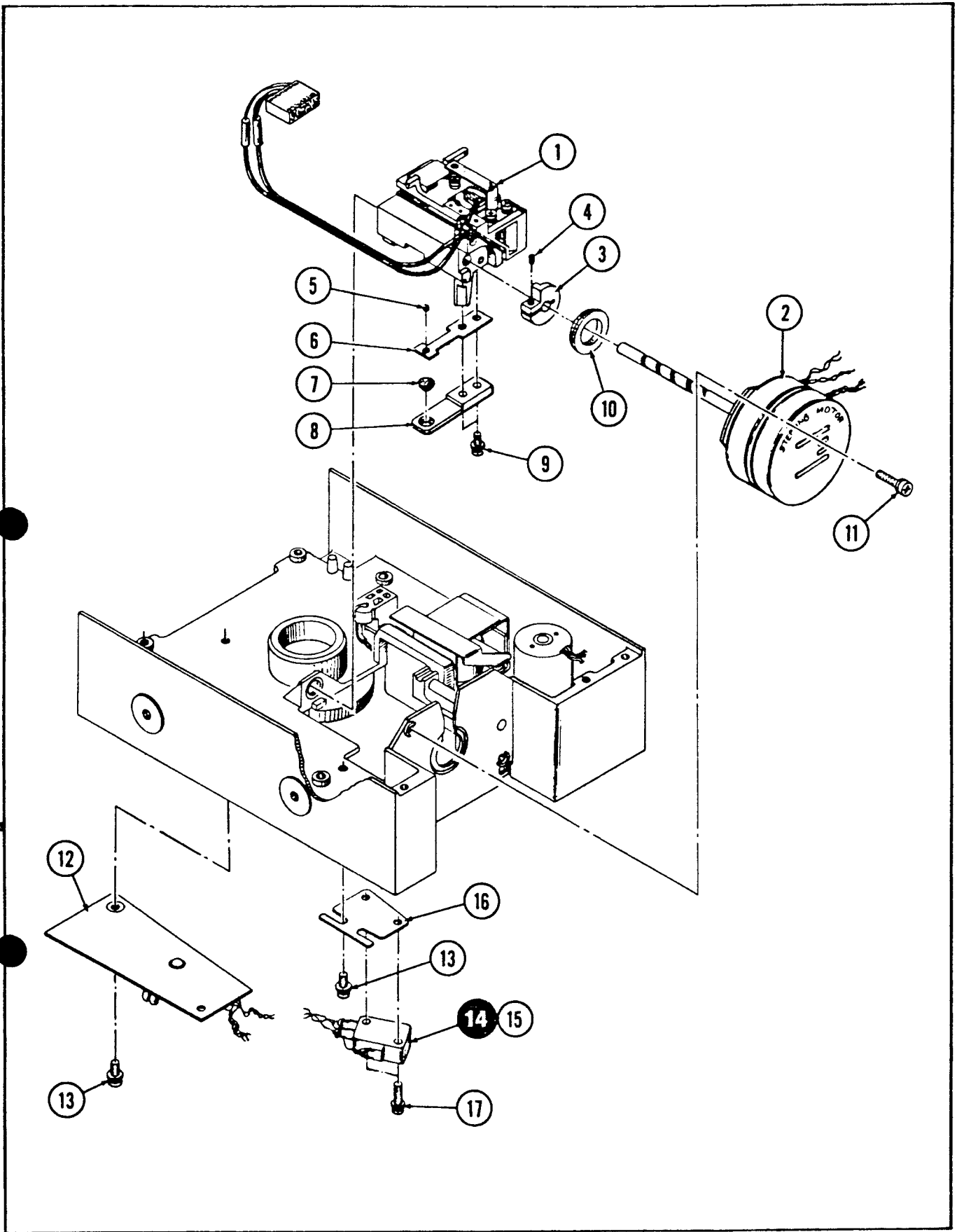

Carriage Stepper Assembly

DataTrak 5 Carriage Stepper Assy. 51156-01

- (1) 51017-01 Carriage Assembly
- (2) 51126-01 Stepper Motor Assembly
- (3) 51007-01 Track 00 Stop
- (4) 51010-08 Socket Head Screw
- (5) 51009-01 Steel Ball
- (6) 51012-01 Plate Spring
- (7) 51014-01 Fur Felt
- (8) 51013-01 Retainer
- (9) 55163-08 Screw, 3mm w/lock & flat washer, 8mm long
- (10) 51006-01 Stepper Collar
- (11) Screw
- (12) 51082-01 Motor Control Board Assembly
- (13) 55173-06 Screw, 3mm w/lock & flat washer, 6mm long
- (14) 51109-01 Track 00 Switch Assembly
(includes 51110-15 & 51111-01)
- (15) 51110-15 Micro Switch
- (16) 51111-01 Switch Base
- (17) 55163-14 Screw, 3mm w/lock washer, 14mm long

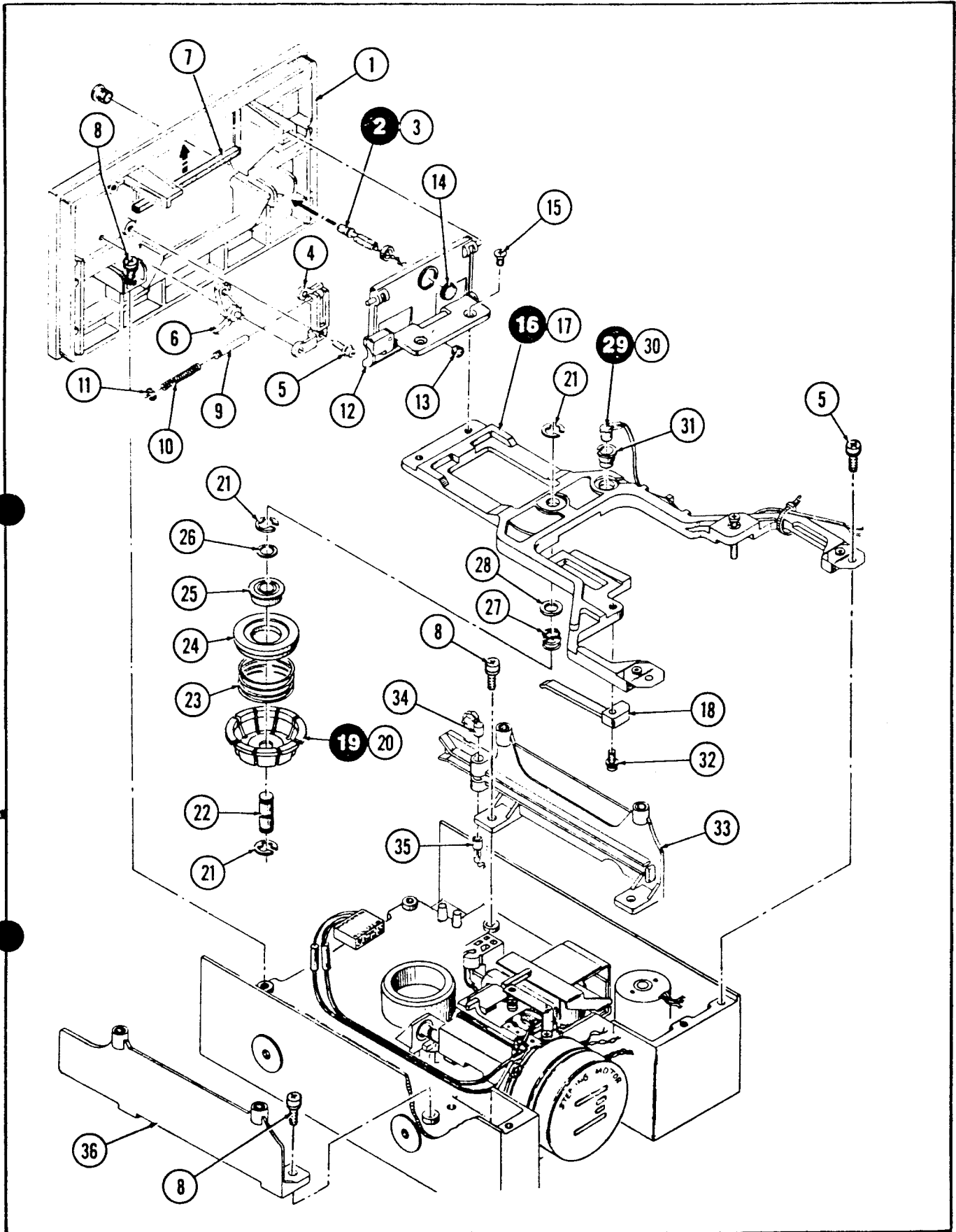

Carrier, Front Bezel and Door

DataTrak 5 Carrier, Front Bezel & Door

- (1) 51123-01 Front Bezel
- (2) 51116-01 LED Assembly (includes 55025-01)
- (3) 55025-01 LED (includes two-piece mounting)
- (4) 51120-01 Anti-Crunch Holder
- (5) 55163-06 Screw, 3mm w/lock & flat washer, 6mm long
- (6) 51119-01 Anti-Crunch Lever
- (7) 51124-01 Bumper, Rubber
- (8) 55173-08 Screw, 3mm w/lock & flat washer 8mm long
- (9) 51121-01 Door Stop Pin
- (10) 51122-01 Pin Return Spring
- (11) 51125-01 E-Ring
- (12) 51104-01 Front Door Assembly (includes 51127-01 & 51107-01)
- (13) 51127-01 Media Push Rubber
- (14) 51107-01 Door Bumper
- (15) 51103-06 Screw, Flat Head
- (16) 51054-01 Carrier Assembly (includes 51055-01, 51061-01, 51068-01)
- (17) 51055-01 Carrier Frame Assembly
- (18) 51061-01 Media Lifter
- (19) 51068-01 Collet Assembly (includes 51069-01, 51077-01, 51073-01, 51072-01, 51070-01, 51074-15, 51076-01, 51071-01, 51075-01)
- (20) 51069-01 Collet
- (21) 51077-01 E-Ring (Requires 3)
- (22) 51073-01 Shaft
- (23) 51072-01 Collet Spring
- (24) 51070-01 Cone
- (25) 51074-15 Bearing
- (26) 51076-01 Shim
- (27) 51071-01 Cone Spring
- (28) 51075-01 Washer
- (29) 51062-01 Index Lamp Assembly (includes 55026-02, 51063-01)
- (30) 55026-02 LED (only)
- (31) 51063-01 Sleeve
- (32) 55163-08 Screw, 3mm w/lock & flat washer 8mm long
- (33) 51034-01 Media Guide (left)
- (34) 51036-01 Write Protect Lamp Assembly
- (35) 51048-01 Write Protect Sensor Assembly
- (36) 51042-01 Media Guide (right)

REMOVAL AND REPLACEMENT PROCEDURES

PRINTED CIRCUIT BOARD

1. Disconnect the DC power cable connector J2, the data cable connector J1, the transducer cable connector J3, and the R/W head cable connector J4 from the PCB.
2. Remove the four screws securing the PCB to the drive. Remove the PCB.
3. Reverse the procedure for installation.

FRONT DOOR ASSEMBLY

Removal (refer to the illustration below)

1. Remove the diskette if installed, and the PCB (refer to the Printed Circuit Board paragraph).
2. Remove the two screws securing the front door to the carrier assembly.
3. Slide the front door out of the front bezel assembly.

Installation (refer to the illustration below)

1. While holding the carrier assembly down, slide the front door into the front bezel assembly.
2. When the front door is in place, the door hinge should rest on the top front edge of the carrier. Secure the front door to the carrier with two screws.
3. Install the PCB (refer to the Printed Circuit Board paragraph).

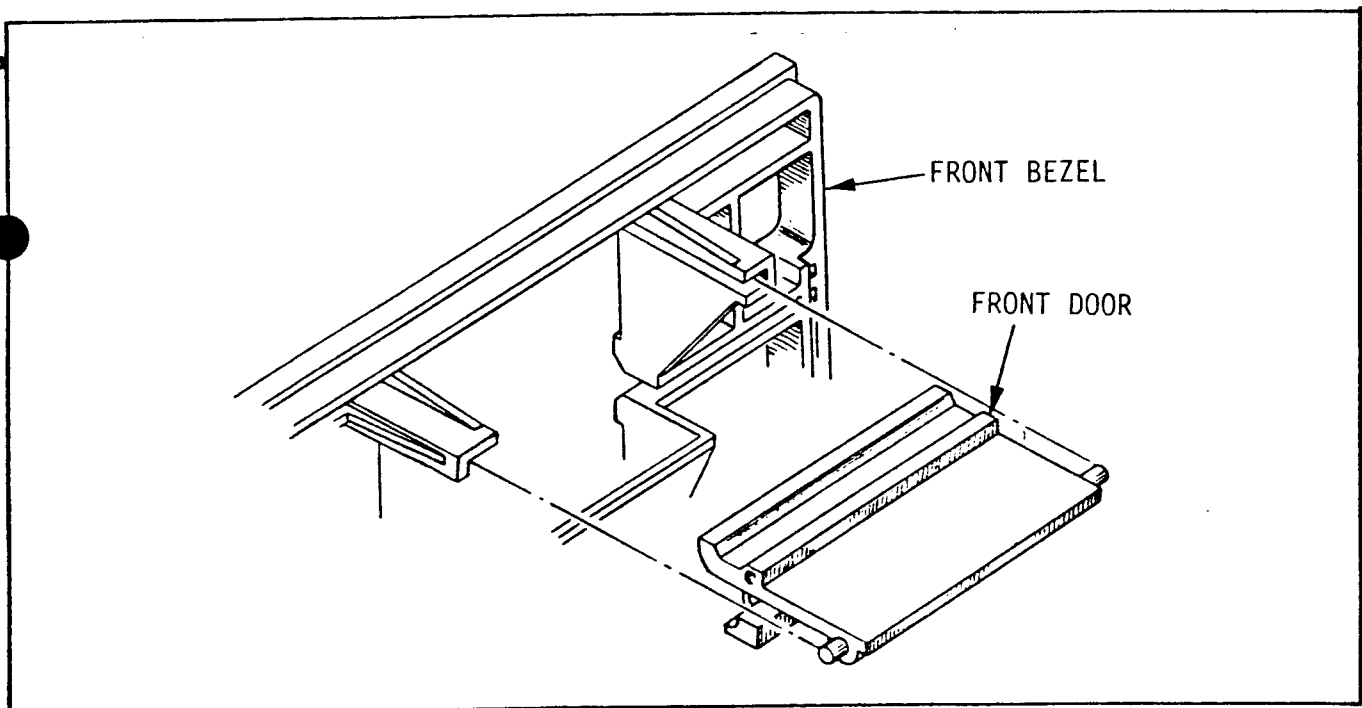

Front Door Installation

FRONT BEZEL ASSEMBLY

Removal

1. Remove the diskette if installed, the PCB, and front door assembly (refer to the Printed Circuit Board and Front Door assembly paragraphs).
2. Remove the two screws securing the front bezel to the main frame.
3. Carefully remove the front bezel from the main frame, being aware that the In Use LED is still secured to the front bezel.
4. With a small screw driver, carefully lift one edge of the LED collar from the LED holder (refer to the illustration below).

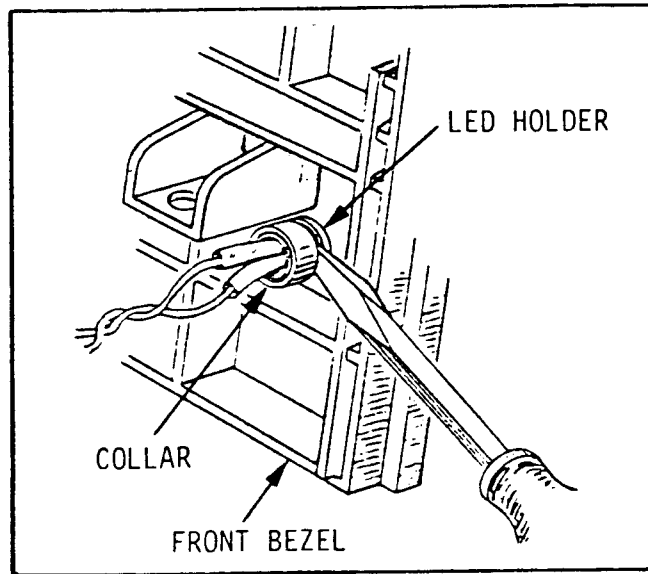

In Use LED Removal

5. Push the In Use LED through the front bezel to break the LED holder loose from the LED collar.
6. Remove the LED holder from the LED. Push the LED back through the front bezel.

Replacement

1. Push the In Use LED through the front bezel.
2. Press the LED holder onto the LED.
3. Push the LED and LED holder into the front bezel. Secure the In Use LED to the front bezel by slipping the LED collar over the LED holder. Be sure the In Use LED is secure in the front bezel (refer to the illustration below).

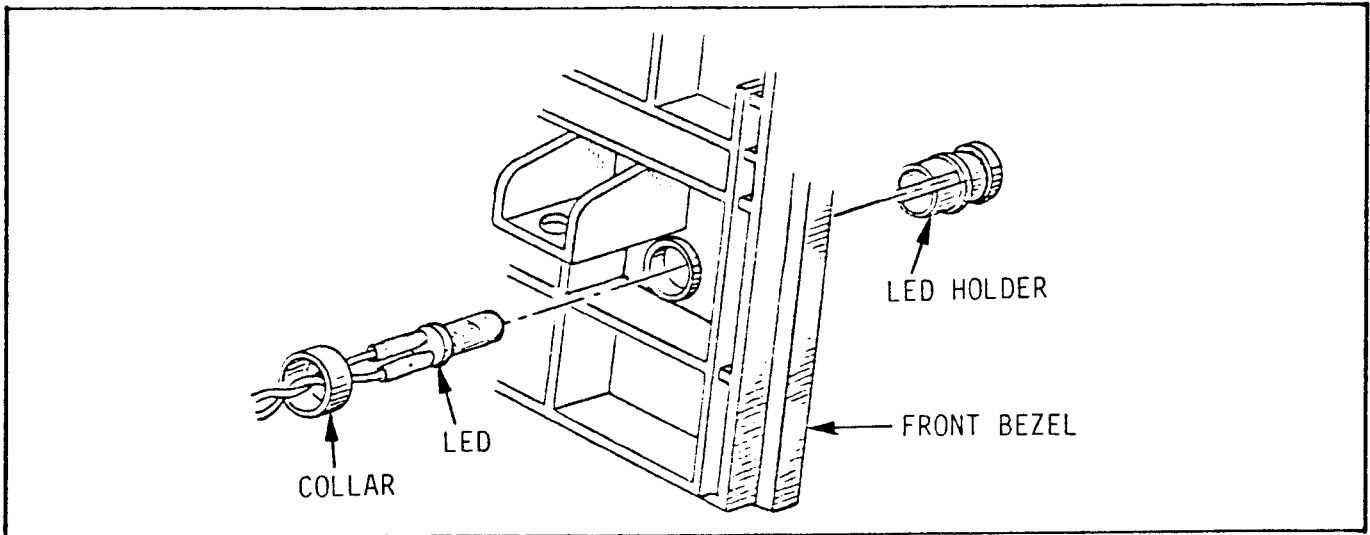

In Use LED Installation

4. Place the front bezel on the main frame and secure with two screws.
5. Install the front door assembly and PCB (refer to the Front Door Assembly and Printed Circuit Board paragraphs).

IN USE LED

Removal

1. Remove the diskette if installed, the PCB, and front bezel assembly (refer to the Printed Circuit Board and Front Bezel Assembly paragraphs).
2. Cut the tie wrap securing the wires near the base of transducer cable connector J3.
3. Remove the two In Use LED leads from connector J3 by pushing down on the LED lead tabs in the connector with tweezers: black to A10, red to B10 (refer to the illustration below).

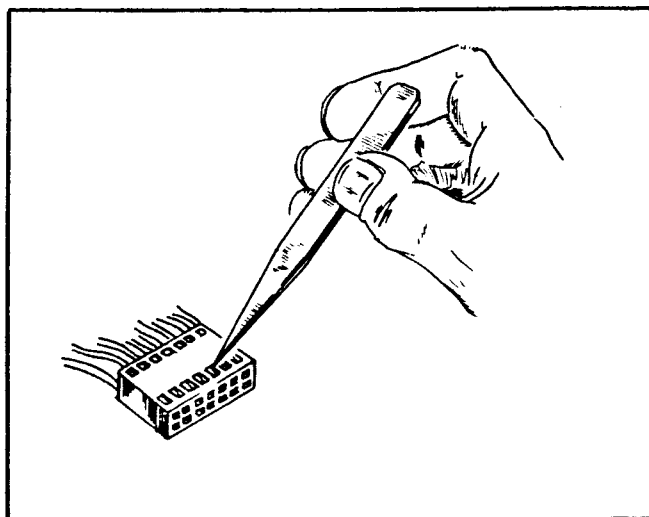

Connector Lead Removal (typical)

4. Separate the two In Use LED leads from the transducer cable, and remove the LED as described in the front bezel assembly removal paragraph. Note the routing of the leads along the cable for later replacement.

Replacement

1. Install the two In Use LED leads in connector J3 (refer to step 3, Removal). Be sure the locking tabs on the leads engage in the connector slots. This will prevent the leads from being pushed out when the connector is plugged into the PCB.
2. Secure the two leads to the transducer cable with a tie wrap near the base of connector J3.
3. Route the In Use LED leads along the transducer cable.
4. Install the In Use LED in the front bezel, (refer to the Front Bezel Assembly Replacement paragraph). Install the front bezel on the main frame.
5. Install the PCB (refer to the Printed Circuit Board paragraph).

MEDIA GUIDES

Removal

1. Remove the diskette if installed, and the PCB (refer to the Printed Circuit Board paragraph).
2. Remove the two R/W head cables (connector J4) from the right media guide (as viewed from the front of the disk drive). Note how the cables are attached to the guide for later replacement.
3. Remove the two screws securing the right media guide to the main frame and remove the guide.
4. Remove the two screws securing the left media guide to the main frame.
5. Carefully remove the left media guide from the main frame, being aware that the write protect sensor and lamp are still secured to the guide. Note how the write protect lamp leads are routed between the guide and the main frame for later replacement.
6. Remove the write protect sensor and lamp from the media guide.

Replacement

1. Install the write protect sensor and lamp in the left media guide. The lamp (yellow and black leads) is installed from the top, and the sensor (orange and black leads) is installed from the bottom.
2. Install the left media guide in the main frame. Be sure the write protect lamp leads are routed between the guide and the main frame through the indentation on the guide.
3. Secure the media guide to the main frame with two screws.

4. Install the right media guide on the main frame and secure with two screws.
5. Attach the two R/W head cables to the right media guide. The cable to side A of connector J4 should be above the cable to side B of the connector.
6. Install the PCB (refer to the Printed Circuit Board paragraph).

WRITE PROTECT SENSOR AND LAMP ASSEMBLY

Removal

1. Remove the diskette if installed, and the PCB (refer to the Printed Circuit Board paragraph).
2. Remove the two screws securing the left media guide to the main frame.
3. Carefully remove the left media guide from the main frame, being aware that the write protect sensor and lamp leads are routed between the guide and the main frame.
4. Remove the write protect sensor and lamp from the media guide.
5. Cut the tie wrap securing the wires near the base of transducer cable connector J3.
6. Remove the four write protect sensor and lamp leads from connector J3 by pushing down on the sensor and lamp lead tabs in the connector with tweezers: (sensor) black to A14, orange to B14, (lamp) black to A13, yellow to B13.
7. Separate the four write protect sensor and lamp leads from the transducer cable, and remove the sensor and lamp. Note the routing of the leads along the cable for later replacement.

Replacement

1. Install the four write protect sensor and lamp leads in connector J3 (refer to step 6 above, Removal). Be sure the locking tabs on the leads engage in the connector slots. This will prevent the leads from being pushed out when the connector is plugged into the PCB.
2. Secure the four leads to the transducer cable with a tie wrap near the base of connector J3.
3. Route the write protect sensor and lamp leads along the transducer cable.
4. Install the write protect sensor and lamp in the left media guide. The lamp (yellow and black leads) is installed from the top, and the sensor (orange and black leads) is installed from the bottom.
5. Install the left media guide on the main frame. Be sure the write protect lamp leads are routed between the guide and the main frame through the indentation on the guide.

6. Secure the media guide to the main frame with two screws.
7. Install the PCB (refer to the Printed Circuit Board paragraph).

CARRIER ASSEMBLY

Removal (refer to the illustration below)

1. Remove the diskette if installed, the PCB, and the front door assembly (refer to the Printed Circuit Board and Front Door Assembly paragraphs).
2. Push the index lamp out of the carrier assembly.
3. Remove the index lamp lead from the carrier assembly. Note how the lead is routed along the carrier for later replacement.
4. Remove the two screws securing the carrier to the main frame.
5. Carefully slide the carrier out from under the head carriage arm and remove the carrier assembly.

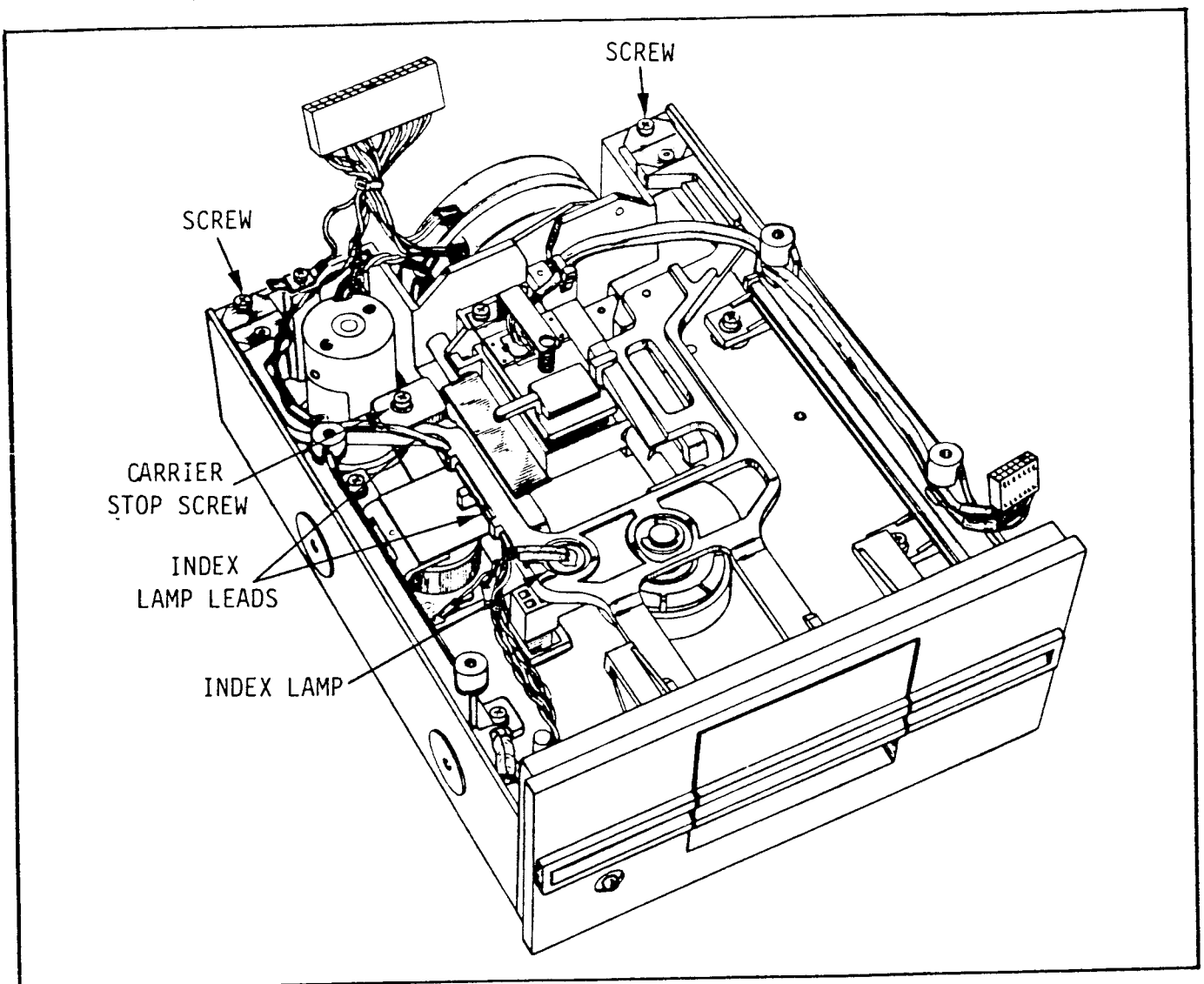

Carrier Assembly Removal and Replacement

Replacement (refer to the illustration above)

1. Carefully install the carrier assembly under the head carriage arm and into position on the main frame. Secure the carrier with two screws.
2. Route the index lamp lead along the carrier as shown, and install the lamp on the carrier.
3. Install the front door assembly (refer to the Front Door Assembly paragraph).
4. Adjust the carrier stop screw for a R/W head gap of 0.004 to 0.01 inch (0.1 to 0.25 mm). Cut two strips of 20 pound bond typing paper to approximately 1 X 3 inches. Place the two paper strips between the R/W head surfaces and close the drive door. Since the combined thickness of the paper strips is about 0.008 inch, a slight tug should be noticed as the paper is moved between the heads. Adjust the carrier stop screw as required. Turning the stop screw clockwise will bring the heads closer together.

CAUTION

Do not allow the R/W heads to come together without a clean piece of paper or a diskette inserted between the head surfaces.

5. Install the PCB (refer to the Printed Circuit Board paragraph).
6. Adjust the index sensor (refer to the ADJUSTMENTS section).

COLLET ASSEMBLY

Removal (refer to the Collet Assembly Removal and Installation illustration)

1. Remove the diskette if installed, the PCB, front door assembly, and carrier assembly (refer to the Printed Circuit Board, Front Door Assembly, and Carrier Assembly paragraphs).
2. Remove the E-ring securing the collet assembly to the carrier and remove the carrier.
3. Remove the E-ring at other end of the collet shaft to remove the collet assembly.

Replacement (refer to the Collect Assembly Removal and Installation)

1. Install the collet assembly parts on the shaft as shown in the Collet Assembly illustration.
2. Install the carrier on the collet assembly and secure with an E-ring.
3. Install the carrier assembly, front door assembly, and PCB on the disk drive (refer to the Carrier Assembly, Front Door Assembly, and Printed Circuit Board paragraphs).

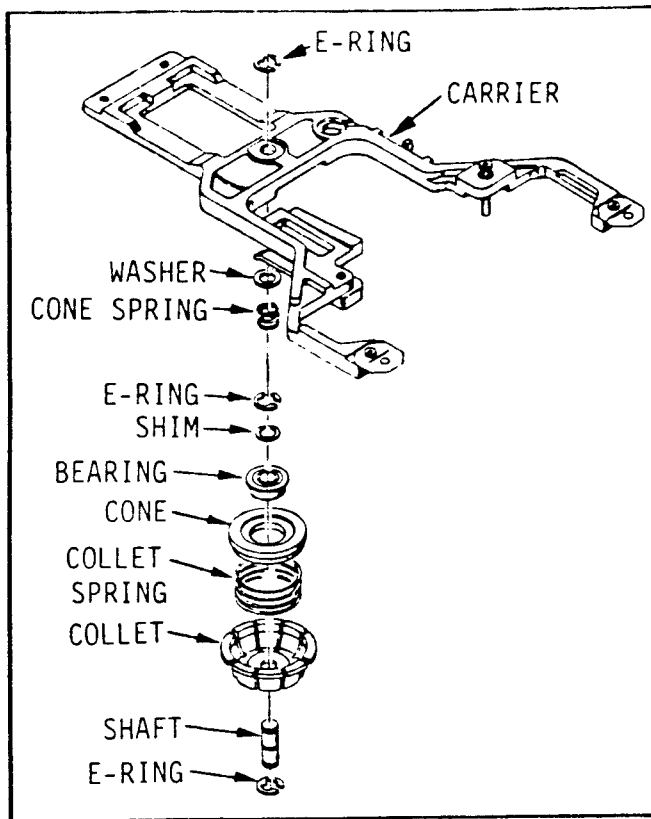

Collet Assembly Removal and Replacement

SPINDLE COMPONENTS

Removal (refer to the Spindle Components Removal and Replacement illustration)

1. Remove the diskette if installed. Remove the PCB, front door assembly, and carrier assembly (refer to the Printed Circuit Board, Front Door Assembly, and Carrier Assembly paragraphs) only if the spindle hub, bearing, and collar are removed.
2. Remove the drive belt from the spindle pulley.
3. While firmly holding the spindle pulley, remove the screw and washer that secures the spindle components to the spindle hub.
4. Remove the desired spindle components.

Replacement (refer to the Spindle Components Removal and Replacement illustration)

1. Install the spindle hub, bearing, and collar, if removed.
2. Install the wave washer, spindle washer, bearing, and spindle pulley, as shown. Secure with a screw and washer.
3. Install the drive belt on the spindle pulley.
4. If the spindle hub, bearing, and collar were removed, install the carrier assembly, front door assembly, and PCB (refer to the Carrier Assembly, Front Door Assembly, and Printed Circuit Board paragraphs).

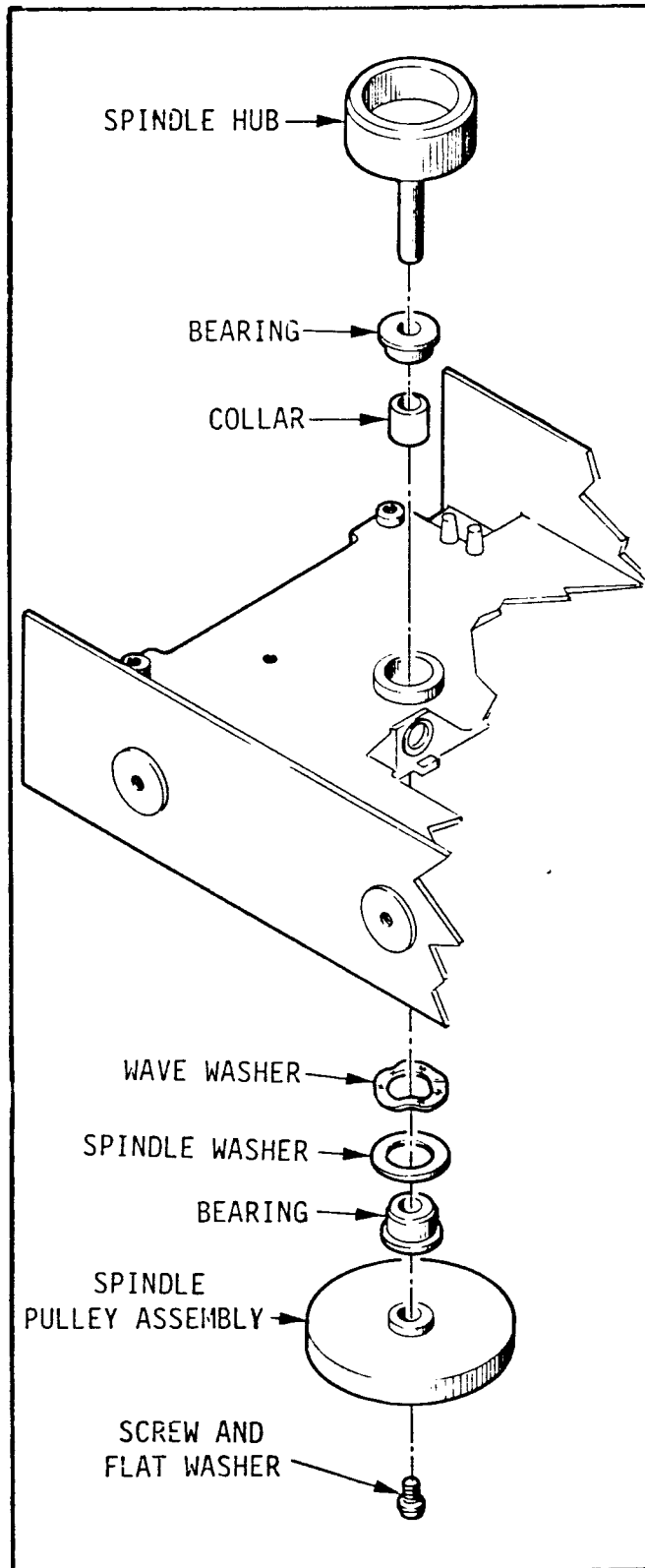

Spindle Components Removal and Replacement

INDEX SENSOR AND LAMP ASSEMBLIES

Removal

1. Remove the diskette if installed, the PCB, front door assembly, and carrier assembly (refer to the Printed Circuit Board, Front Door Assembly, and Carrier Assembly paragraphs). When removing the carrier assembly, note how the two index lamp leads are routed along the carrier.
2. Remove the screw and washer securing the index sensor to the main frame. Remove the sensor. Note how the two sensor leads are routed along the main frame to the transducer cable connector J3.
3. Cut the tie wrap securing the wires near the base of connector J3.
4. Remove the four index sensor and lamp leads from connector J3 by pushing down on the sensor and lamp lead tabs in the connector with tweezers: (sensor) black to A12, blue to B12, (lamp) black to A11, white to B11.
5. Separate the four index sensor and lamp leads from the transducer cable, and remove the sensor and lamp.

Replacement

1. Install the four index sensor and lamp leads in connector J3 (refer to step 4 above, Removal). Be sure the locking tabs on the leads engage in the connector slots. This will prevent the leads from being pushed out when the connector is plugged into the PCB.
2. Secure the four leads to the transducer cable with a tie wrap near the base of connector J3.
3. Install the index sensor in the main frame, as shown in the illustration below. Secure the sensor with a screw and washer.

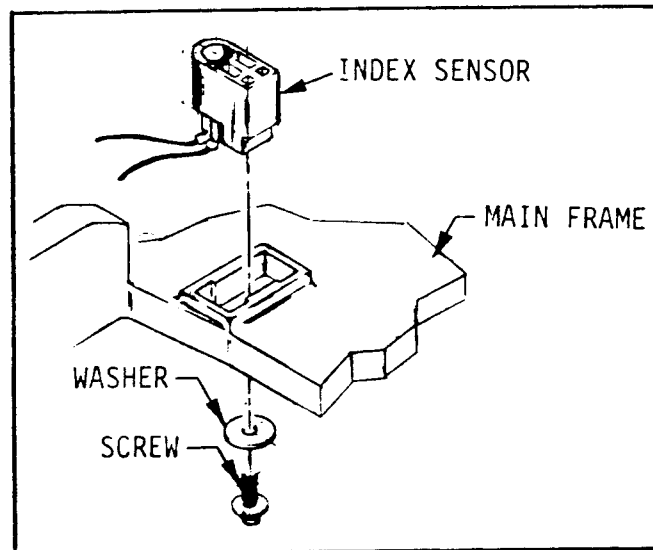

Index Sensor Installation

4. Install the carrier assembly and index lamp (refer to the Carrier Assembly paragraph).
5. Install the front door assembly and PCB (refer to the Front Door Assembly and Printed Circuit Board paragraphs).
6. Adjust the index sensor with the index lamp (refer to the ADJUSTMENTS section).

HEAD LOAD SOLENOID ASSEMBLY

Removal

1. Remove the diskette if installed, the PCB, front door assembly, carrier assembly, and left media guide as viewed from the front of the disk drive (refer to the Printed Circuit Board, Front Door Assembly, Carrier Assembly, and Media Guide paragraphs).
2. Remove the screw securing the head load solenoid to the main frame. Note how the two solenoid leads are routed along the main frame to the transducer cable connector J3.
3. Cut the tie wrap securing the wires near the base of connector J3.
4. Remove the two head load solenoid leads from connector J3 by pushing down on the solenoid lead tabs in the connector with tweezers: green to A4, white to B4.
5. Separate the two head load solenoid leads from the transducer cable, and remove the solenoid.

Replacement

1. Install the two head load solenoid leads in connector J3 (refer to step 4 above, Removal). Be sure the locking tabs on the leads engage in the connector slots. This will prevent the leads from being pushed out when the connector is plugged into the PCB.
2. Secure the two leads to the transducer cable with a tie wrap near the base of connector J3.
3. Route the two head load solenoid leads along the main frame and install the solenoid. Slide the metal solenoid arm under the head carriage arm. Be sure the key at the bottom of the solenoid is in the main frame slot.
4. Secure the head load solenoid with a screw.
5. Install the left media guide, the carrier assembly, front door assembly, and PCB (refer to the Media Guides, Carrier Assembly, Front Door Assembly, and Printed Circuit Board paragraphs).

MOTOR CONTROL BOARD

Removal

1. Remove the diskette if installed, the DC power cable connector J2, and transducer cable connector J3 from the PCB.
2. Cut the tie wrap securing the wires near the base of connector J3.
3. Remove the three motor control board leads from connector J3 by pushing down on the control board lead tabs in the connector with tweezers: blue to A1, red to B1, and black to B2.
4. Separate the three motor control board leads from the transducer cable by cutting the two tie wraps attached to the main frame under the stepper motor.
5. Remove the two screws securing the motor control board to the main frame.
6. With soldering equipment, remove the four drive motor leads from the motor control board: 1-red, 2-blue, 3-green, and 4-yellow. Numeric references are indicated on the component side of the board (refer to the illustration below).

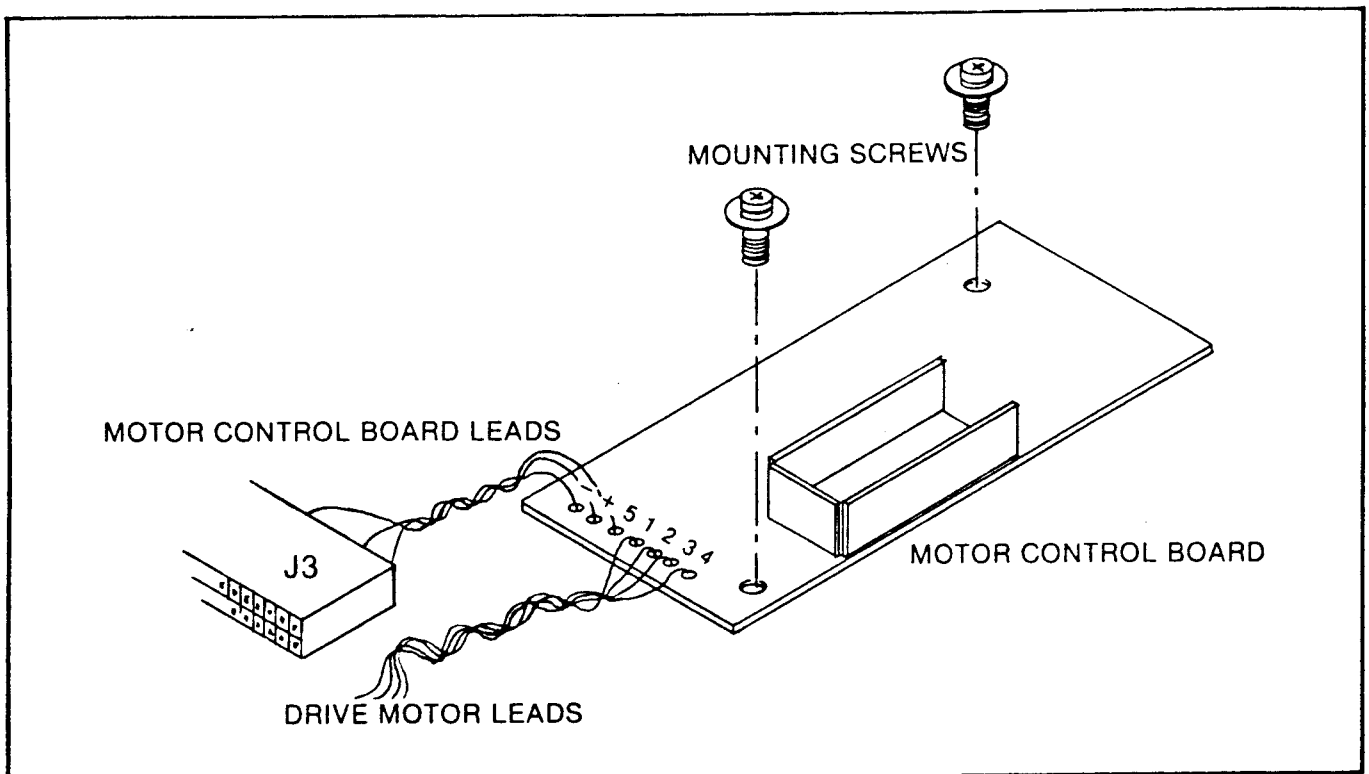

Motor Control Board - Drive Motor Leads

7. Remove the motor control board.

Replacement

1. With soldering equipment, secure the four drive motor leads to the motor control board (refer to step 6, Removal).
2. Install the motor control board on the main frame, and secure with two screws.
3. Secure the three motor control board leads, four drive motor leads, and two track 00 switch leads along the main frame with two tie wraps. Attach the tie wraps to the main frame at the two holes under the stepper motor.
4. Install the three motor control board leads in connector J3 (refer to step 3, Removal). Be sure the locking tabs on the leads engage in the connector slots. This will prevent the leads from being pushed out when the connector is plugged into the PCB.
5. Secure the leads to the transducer cable with a tie wrap near the base of connector J3.
6. Install connectors J2 and J3 on the PCB.
7. Adjust the drive motor (refer to the ADJUSTMENTS section).

DRIVE MOTOR

Removal

1. Remove the diskette if installed, the DC power cable connector J2, and transducer cable connector J3 from the PCB.
2. Separate the four drive motor leads from the transducer cable by cutting the two tie wraps attached to the main frame under the stepper motor.
3. Remove the two screws securing the motor control board to the main frame.
4. With soldering equipment, remove the four drive motor leads from the motor control board: 1-red, 2-blue, 3-green, and 4-yellow. Numeric references are indicated on the component side of the board (refer to the illustration above).
5. Remove the drive belt.
6. Remove the two screws securing the drive motor to the main frame. Remove the drive motor.

Replacement

1. Install the drive motor on the main frame and secure with two screws.
2. Install the drive belt.
3. With soldering equipment, secure the four drive motor leads to the motor control board (refer to step 4 above, Removal).
4. Install the motor control board on the main frame and secure with two screws.
5. Secure four drive motor leads, three motor control leads, and two track 00 switch leads along the main frame with two tie wraps. Attach the tie wraps to the main frame at the two holes under the stepper motor.
6. Install connectors J2 and J3 on the PCB.
7. Adjust the drive motor (refer to the ADJUSTMENTS section).

TRACK 00 SWITCH ASSEMBLY

Removal

1. Remove the diskette if installed, the DC power cable connector J2, and transducer cable connector J3 from the PCB.
2. Cut the tie wrap securing the wires near the base of connector J3.
3. Remove the three track 00 switch leads from connector J3 by pushing down on the switch lead tabs in the connector with tweezers: yellow to A8, green to A9, and white to B9.
4. Separate the three track 00 switch leads from the transducer cable by cutting the two tie wraps attached to the main frame under the stepper motor.
5. Remove the two screws securing the track 00 switch and base to the main frame.
6. Remove the two screws securing the track 00 switch to the switch base.

Replacement

1. Secure the track 00 switch to the switch base with two screws.
2. Install the track 00 switch and base on the main frame, and secure with two screws.

3. Secure the three track 00 switch leads, three motor control board leads, and four drive motor leads along the main frame with two tie wraps. Attach the tie wraps to the main frame at the two holes under the stepper motor.
4. Install the three track 00 switch leads in connector J3 (refer to step 3, Removal). Be sure the locking tabs on the leads engage in the connector slots. This will prevent the leads from being pushed out when the connector is plugged into the PCB.
5. Secure the leads to the transducer cable with a tie wrap near the base of connector J3.
6. Install connectors J2 and J3 on the PCB.
7. Adjust the track 00 switch (refer to the ADJUSTMENTS section).

HEAD CARRIAGE ASSEMBLY

Removal (refer to the illustration below)

1. Remove the diskette if installed, the PCB, and the door carrier assembly (refer to the Printed Circuit Board and Carrier Assembly paragraphs).

CAUTION

The R/W heads must not be allowed to come together. Insert a clean piece of paper between the head surfaces.

2. Remove the two R/W head cables (connector J4) from the right media guide (as viewed from the front of the disk drive). Note how the cables are attached to the guide for later replacement.
3. Cut the tie wrap securing the wires near the base of connector J3.
4. Remove the six stepper motor leads from connector J3 by pushing down on the motor lead tabs in the connector with tweezers: black to A5, yellow to A6, brown to A7, red to B5, red to B6, and orange to B7.
5. From the underside of the carriage assembly, remove the two Phillips head screws and washers that secure the retainer, plate spring, steel ball and carriage to the shaft of the stepper motor.
6. Remove the two Phillips head screws, lock washers, and flat washers that secure the stepper motor to the main frame. Lift the stepper motor and carriage free.
7. Slide the carriage from the shaft of the stepper motor and remove.

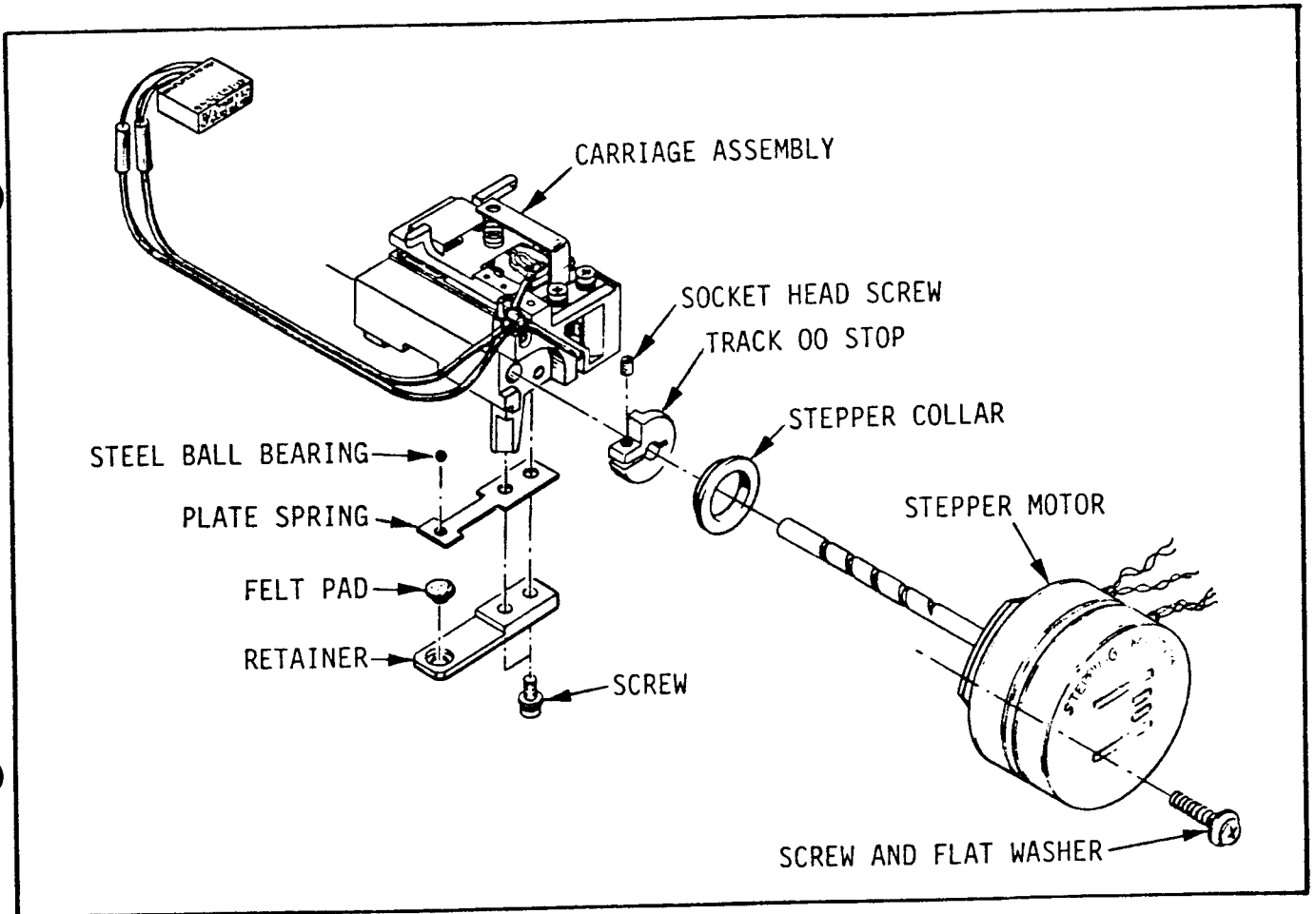

STEPPER MOTOR AND HEAD CARRIAGE REMOVAL AND INSTALLATION

REPLACEMENT (refer to the illustration above)

1. Slide the carriage assembly onto the stepper motor shaft and install as a unit in the main frame. Loosely tighten the two stepper motor mounting screws to hold the motor in place.
2. Slide the carriage to its forward limit and position the stepper motor shaft so as to locate a point in the spiral groove that is in line with the screw holes used to mount the plate spring and retainer.
3. Apply a small dab of grease in the hole of the plate spring. Place the steel ball in the greased hole and install the plate spring in the carriage. When properly aligned the steel ball should ride in the spiral groove with the plate spring perpendicular to the stepper motor shaft.
4. Apply a drop of light lubricating oil to the fur felt in the retainer. Install the retainer with the fur felt against the steel ball in the plate spring and secure all in place on the carriage with two Phillips head screws and washers.
5. Install the six stepper motor leads in connector J3 by inserting the lead tabs into the connector slots as follows: black to A5, yellow to A6, brown to A7, red to B5, red to B6, and orange to B7.
6. Secure all leads terminating in connector J3 with a tie wrap near the base of the connector.
7. Secure the two R/W head cables on the right media guide.
8. Install the door carrier assembly and the PCB (refer to the Carrier Assembly and Printed Circuit Board paragraphs).
9. Adjust the track 00 switch, track 00 stop and the stepper motor as necessary (refer to the Adjustments section).

STEPPER MOTOR

Removal (refer to the Stepper Motor and Head Carriage Removal and Installation illustration).

1. Remove the diskette if installed, and the PCB (refer to the Printed Circuit Board paragraph)

CAUTION

The R/W heads must not be allowed to come together. Insert a clean piece of paper between the head surfaces.

2. Cut the tie wrap securing the wires near the base of connector J3.

3. Remove the six stepper motor leads from connector J3 by pushing down on the motor lead tabs in the connector with tweezers: black to A5, yellow to A6, brown to A7, red to B5, red to B6, and orange to B7.
4. From the underside of the carriage assembly, remove the two Phillips head screws and washers that secure the retainer, plate spring, steel ball and carriage to the shaft of the stepper motor.
5. Remove the two Phillips head screws, lock washers, and flat washers that secure the stepper motor to the main frame. Slide the stepper motor shaft out of the head carriage and remove the motor from the main frame.
6. Remove the track 00 stop and stepper collar from the motor shaft.

Replacement (refer to the Stepper Motor and Head Carriage Removal and Installation illustration)

1. Install the stepper collar on the stepper motor shaft with the flange side against the motor. Next install the track 00 stop on the stepper motor shaft with the flat side toward the stepper collar. Do not tighten the socket head screw since adjustment will be required later.
2. Insert the shaft of the stepper motor into the head carriage assembly and install the motor in the main frame. Loosely tighten the stepper motor mounting screws to hold the motor in place.
3. Slide the carriage to its forward limit and position the stepper motor shaft so as to locate a point in the spiral groove that is in line with the screw holes used to mount the plate spring and retainer.
4. Apply a small dab of grease in the hole of the plate spring. Place the steel ball in the greased hole and install the plate spring in the carriage. When properly aligned the steel ball should ride in the spiral groove with the plate spring perpendicular to the stepper motor shaft.
5. Apply a drop of light lubricating oil to the fur felt in the retainer. Install the retainer with the fur felt against the steel ball in the plate spring and secure all in place on the carriage with two Phillips head screws and washers.
6. Install the six stepper motor leads in connector J3 by inserting the lead tabs into the connector slots as follows: black to A5, yellow to A6, brown to A7, red to B5, red to B6, and orange to B7.
7. Secure all leads terminating in connector J3 with a tie wrap near the base of the connector.
8. Install the PCB (refer to the Printed Circuit Board paragraph).
9. Adjust the track 00 switch, track 00 stop and the stepper motor as necessary (refer to the Adjustments section).

Test Equipment and Tools Required

Oscilloscope	Tektronics 465 or equivalent
Exerciser	System controller or drive exerciser/tester
CE Diskette	Q.P.N. 51197-01
Allen Driver	1.5 mm
Feeler Gauge	0.027 inch (0.7mm)
Phillips Screwdriver (2)	#1 Head, 4 inch shank; #2 Head, 4 inch shank
Flat Head Screwdriver	4 inch shank

CAUTION

The R/W heads must not be allowed to come together without a diskette or clean piece of paper inserted between the head surfaces.

DRIVE MOTOR ADJUSTMENT

The DataTrak 5 drive motor speed can be visually verified by referencing the "strobing effect" produced by the decal on the spindle pulley. The decal has two scales: a 50 Hz scale for use under artificial light produced by 50 Hz voltage, and a 60 Hz scale for use under artificial light produced by 60 Hz voltage. To check and/or adjust the drive motor speed proceed as follows:

1. Position the drive on its side in a well lighted area. Good lighting is important so that the "strobing effect" produced by the decal can be more easily recognized.
2. Install a diskette of known integrity in the disk drive.
3. Power up the disk drive so that the drive motor is turning the spindle pulley.
4. While observing the appropriate ring (50 Hz or 60 Hz) on the spindle pulley decal, slowly adjust VR1 on the motor control board until a "strobing effect" is seen. Motor speed is properly adjusted when the white/black pattern on the decal ring appears to be motionless and pulsate or flash - that is, to strobe.

HEAD ALIGNMENT ADJUSTMENT

NOTE

For a more precise adjustment it is recommended that the disk drive be oriented (vertically or horizontally) while on the test bench, in its "in-service" condition.

1. Set the oscilloscope controls as follows:

VOLTS/DIV (CH1 & CH2)	50 mv
VAR KNOB (CH1 & CH2)	CAL
CH2	INVERT
VERT MODE	ADD
AC/GND/DC (CH1 & CH2)	AC
HORZ DISPLAY	A
TRIG MODE	NORM
TRIG COUPLING	AC
A/B TIME/DIV	20 ms
SLOPE	+
SOURCE	EXTERNAL

2. Power up the disk drive.

3. Install a CE diskette, Q.P.N. 51197-01, in the disk drive.

4. Connect the oscilloscope channel probes 1 and 2 to TP1A and TP1B (R/W head signals) respectively, and the trigger probe to TP3 (Index) on the PCB. Connect the probe ground leads to the GND test point.

5. Step the head carriage "IN" on the diskette. Repeat until a "cats-eye" pattern is observed on the oscilloscope as shown below. For optimum performance LOBE A should equal LOBE B, or at least relate such that

$$\frac{A}{B} \geq 80\%.$$

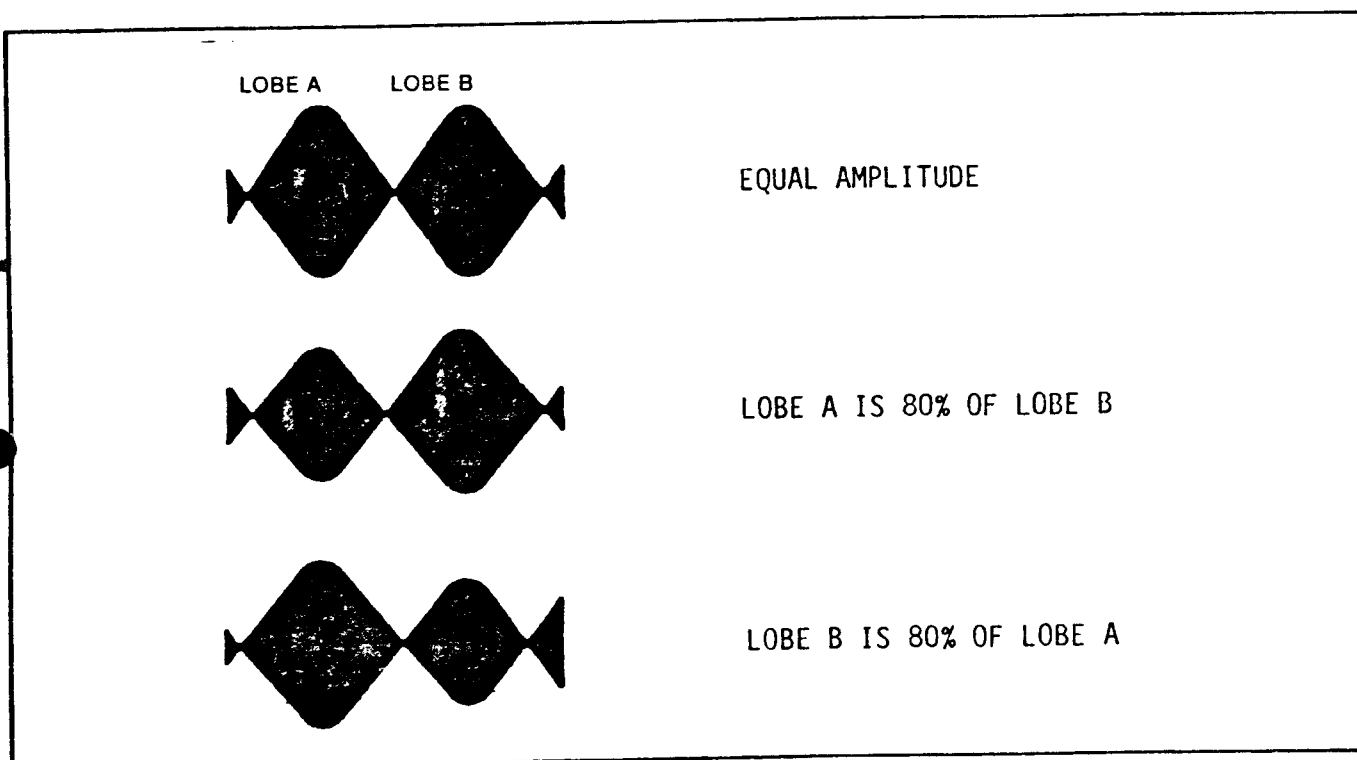

"Cats-eye" Pattern

6. A "cats-eye" pattern should appear on the oscilloscope. If not, move the head carriage on the closest even numbered track that affords an approximate "cats-eye" pattern.
7. If adjustment is necessary, loosen the two stepper motor mounting screws. While observing the oscilloscope, slowly rotate the stepper motor into a position where LOBE A equals LOBE B. Secure the mounting screws.
8. Disconnect the oscilloscope probes from the PCB and remove the diskette from the drive. Power down the disk drive.

TRACK 00 SWITCH ADJUSTMENT

1. Verify head alignment (refer to the HEAD ALIGNMENT ADJUSTMENT paragraph, steps 1 through 7).
2. Single step the head carriage "OUT" 16 times. This will locate the head carriage on TRACK 00.
3. Disconnect the oscilloscope probes from the PCB.
4. Set the oscilloscope controls as follows:

VOLTS/DIV (CH1)	2
VAR KNOB (CH1)	CAL
VERT MODE	CH1
AC/GND/DC	DC
TRIG MODE	AUTO
5. Connect the oscilloscope channel 1 probe to TP5 (Track 00) on the PCB. Connect the probe ground to the GND test point.
6. Observe on the oscilloscope a high (4V) level. If necessary to adjust, loosen the TRACK 00 switch mounting screws, and reposition the switch to obtain the desired 4V level. Secure the switch mounting screws.
7. Alternate the head carriage between TRACK 00 and TRACK 01 several times. Observe that on TRACK 00 a high (4V) is indicated on the oscilloscope, and on TRACK 01 a low (0V) level. Repeat step 6 as necessary to obtain the proper levels.
8. Disconnect the oscilloscope probes from the PCB and remove the diskette from the drive. Power down the disk drive.

TRACK 00 STOP ADJUSTMENT

1. Verify that the TRACK 00 switch is properly adjusted and that the head carriage is located at TRACK 00 (refer to the TRACK 00 SWITCH ADJUSTMENT paragraph).
2. With a feeler gauge, check the gap between the head carriage and the TRACK 00 stop as shown below. The correct tolerance is 0.027 inch (0.7 mm \pm 0.05 mm).

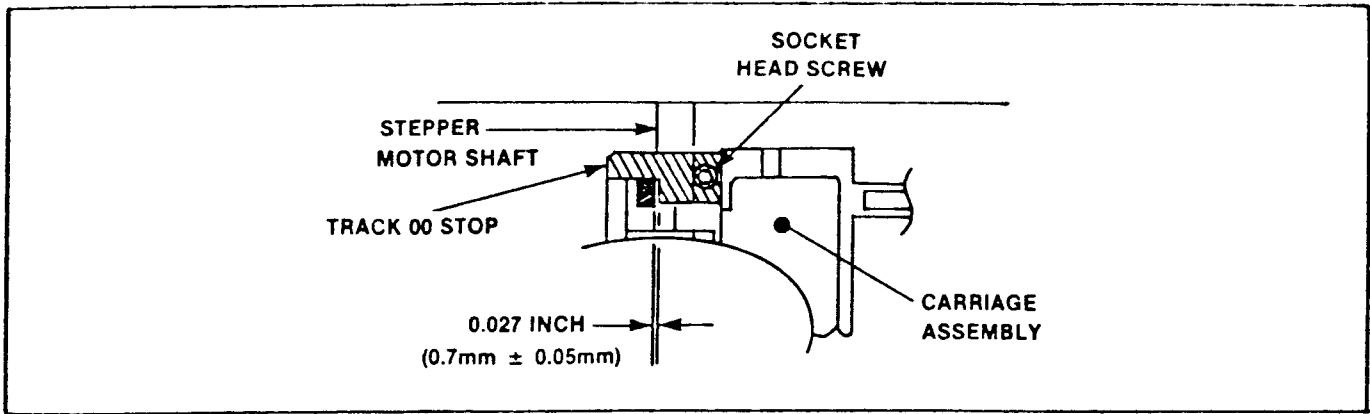

Track 00 Stop Adjustment

3. If adjustment is necessary, loosen the screw that secures the stop on the stepper motor shaft with a 1.5 mm allen driver. Move the stop until it affords the proper gap, and secure in place.

INDEX SENSOR ADJUSTMENT

1. Set the oscilloscope controls as follows:

VOLTS/DIV (CH1 & CH2)	50 MV
VAR KNOB (CH1 & CH2)	CAL
CH2	INVERT
VERT MODE	ADD
AC/GND/DC (CH1 & CH2)	AC
HORZ DISPLAY	A
TRIG MODE	NORM
TRIG COUPLING	AC
A/B TIME/DIV	0.2 ms
SLOPE	+
SOURCE	EXTERNAL

2. Power up the disk drive.
3. Install a CE diskette, Q.P.N. 51197-01, in the disk drive.
4. Connect the oscilloscope channel probes 1 and 2 to TP1A and TP1B (R/W head signals) respectively, and the trigger probe to TP3 (Index) on the PCB. Connect the probe ground leads to the GND test point.
5. Step the head carriage "IN" to TRACK 01.
6. Observe on the oscilloscope the index burst pattern shown below.

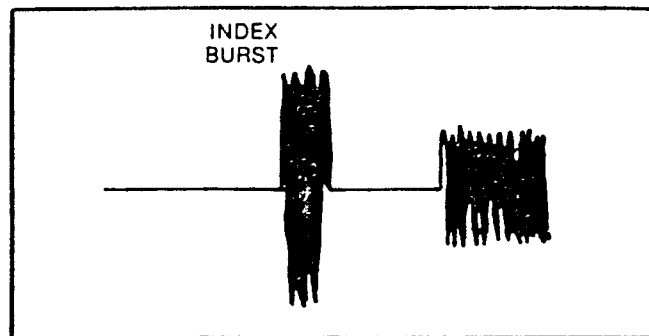

Index Burst Pattern

7. If the index burst occurs 400 us \pm 100us after the start of the index pulse, no adjustment is necessary. Otherwise, loosen the index sensor mounting screw. With the blade of a screwdriver placed between the sensor and the main frame, gently move the sensor into proper adjustment (400us \pm 100us) while monitoring the oscilloscope. Tighten the mounting screw.
8. Disconnect the oscilloscope probes from the PCB and remove the diskette from the dirve. Power down the disk drive.

AZIMUTH ALIGNMENT CHECK

The AZIMUTH ALIGNMENT CHECK procedure is presented as a guideline for determining the degree of R/W head alignment integrity. The entire head/carriage assembly is factory adjusted and tested; there is no field adjustment. Replace the entire assembly if defective.

1. Set the oscilloscope as follows:

VOLTS/DIV (CH1 & CH2)	50 mv
VAR KNOB (CH1 & CH2)	CAL
CH2	INVERT
VERT MODE	ADD
AC/GND/DC (CH1 & CH2)	AC
HORZ DISPLAY	A
TRIG MODE	NORM
TRIG COUPLING	AC
A/B TIME/DIV	0.5 ms
SLOPE	+
SOURCE	EXTERNAL

2. Power up the disk drive.
3. Install a CE diskette, Q.P.N. 51197-01, in the disk drive and step the head carriage "IN" to TRACK 34. Activate SIDE SELECT 0.
4. Connect the oscilloscope channel probes 1 and 2 to TP1A and TP1B (R/W head signals) respectively, and the trigger probe to TP3 (Index) on the PCB. Connect the probe ground leads to the GND test point.
5. Observe the oscilloscope for a pattern similar to that shown in the Azimuth Check illustration.
6. Activate SIDE SELECT 1 and repeat step 5.
7. Disconnect the oscilloscope probes from the PCB and remove the diskette from the drive. Power down the disk drive.

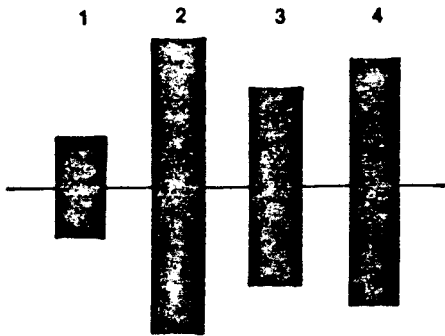

MAXIMUM ALLOWABLE AZIMUTH ERROR OF +18 MINUTES. BURST #4 IS 25% LARGER IN AMPLITUDE THAN BURST #3.

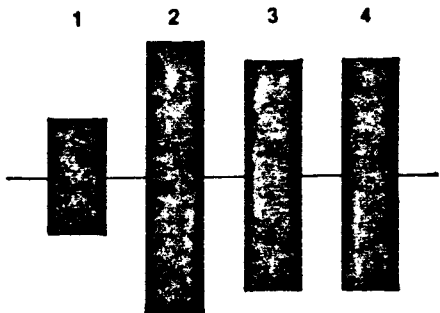

TYPICAL AZIMUTH ERROR OF +12 MINUTES. BURSTS #3 AND #4 ARE EQUAL IN AMPLITUDE.

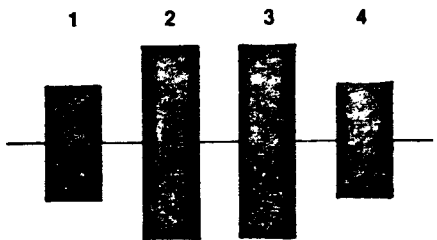

AN OPTIMUM ALIGNMENT OF ZERO MINUTES AZIMUTH ERROR. BURSTS #1 AND #4 ARE EQUAL IN AMPLITUDE, AS ARE BURSTS #2 AND #3.

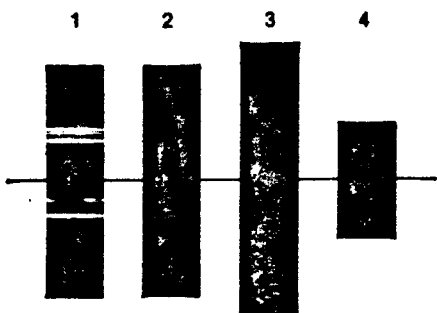

TYPICAL AZIMUTH ERROR OF -12 MINUTES. BURSTS #1 AND #2 ARE EQUAL IN AMPLITUDE.

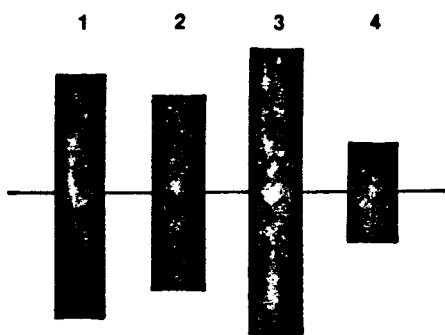

MAXIMUM ALLOWABLE AZIMUTH ERROR OF -18 MINUTES. BURST #1 IS 25% LARGER IN AMPLITUDE THAN BURST #2.

USING A QUME CERTIFIED 12 MINUTE CE DISK (QUME P.N. 51197-01) THE AZIMUTH SHALL BE ACCEPTABLE IF A DRIVE SHOWS LESS THAN THE MAXIMUM ALLOWABLE 18 MINUTE AZIMUTH. THE MAXIMUM ALLOWABLE AZIMUTH IS CONSIDERED TO BE ATTAINED WHEN BURST #1 IS 25% LARGER THAN BURST #2, OR IF BURST #4 IS 25% LARGER THAN BURST #3.

003-A-009

Azimuth Check

TROUBLESHOOTING

GENERAL

This section presents troubleshooting information dealing with the most common DataTrak 5 functional errors; namely, Not Ready, Seek Error, Read Error, Write Errors, and No Head Load. The troubleshooting of these errors is accomplished in flowchart format.

DEFINITION OF DATATRAK 5 FUNCTIONAL ERRORS

Not Ready

A condition in which the controller fails to receive a READY signal from the disk drive when it expects to receive one.

Seek Error

A condition in which the drive is unable to access a particular diskette side or track, or to confirm track 00 access to the controller.

Read Error

A condition in which the drive is unable to recover data previously written onto the diskette.

Write Error

A condition in which the drive is unable to write data onto a diskette.

No Head Load

A condition in which the R/W head fails to load onto the diskette. This condition may be associated with any of the above errors.

TROUBLESHOOTING TECHNIQUE

Effective troubleshooting should always begin with a visual inspection. Look for such things as faulty wiring, damaged or misaligned components, and the presence of any foreign matter such as dust. Inspect for anything that can obviously alter performance of the drive.

Next, proceed to isolate the problem to the diskette, drive, or controller. Malfunctions that are diskette related can be easily detected by comparing the performance of the suspect diskette to one known to be in good condition. Most diskette problems can be attributed to either soft or hard errors. Soft errors resulting from contamination by dust and/or body oil on the diskette surface are usually caused by careless handling. Soft errors diminish the accurate read/write capability of the diskette, but do not necessarily render the diskette unusable. Conversely, hard errors caused by such things as scratches and abrasions permanently damage the medium.

Likewise, the drive unit can be determined defective or not by exchanging the original unit with one that is known to be operable. Verify that the drive is installed correctly. Specifically, check to see that the voltage requirements are supplied and that the strappable options are correctly placed. Proceed to the troubleshooting flowcharts for further isolation of a drive unit fault.

Once the drive unit is found to be functional, verify that the interface and controller programming are viable.

TROUBLESHOOTING FLOWCHARTS

To proceed through the following troubleshooting flowcharts it is necessary to have the following equipment:

- A diskette of known integrity; CE diskette, Q.P.N. 51197-01, may be helpful.
- Multimeter, 20,000 ohms/volt (Triplett, model 310 or equivalent).
- Oscilloscope, dual trace (Tektronics model 465 or equivalent).

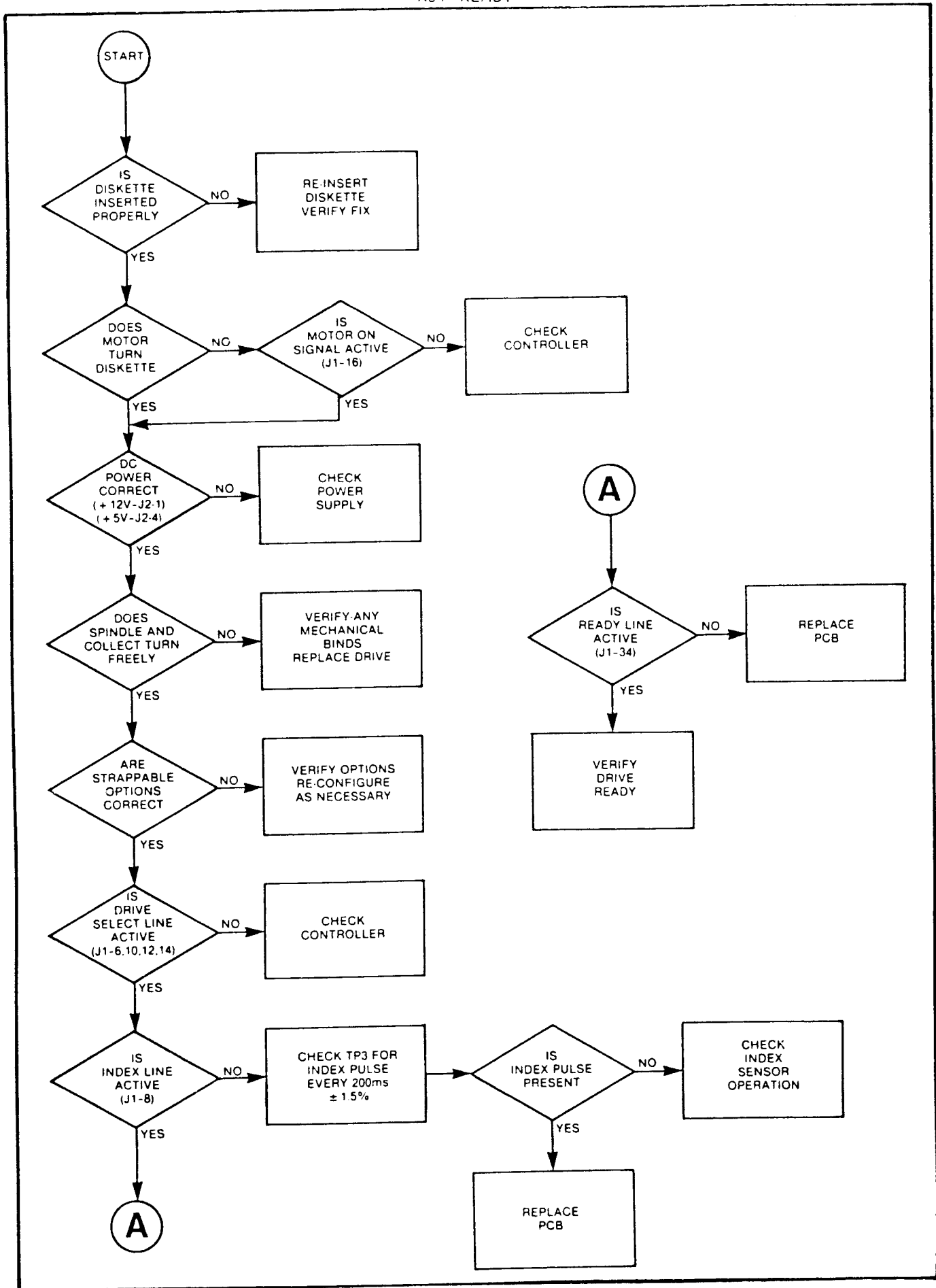

SEEK ERROR

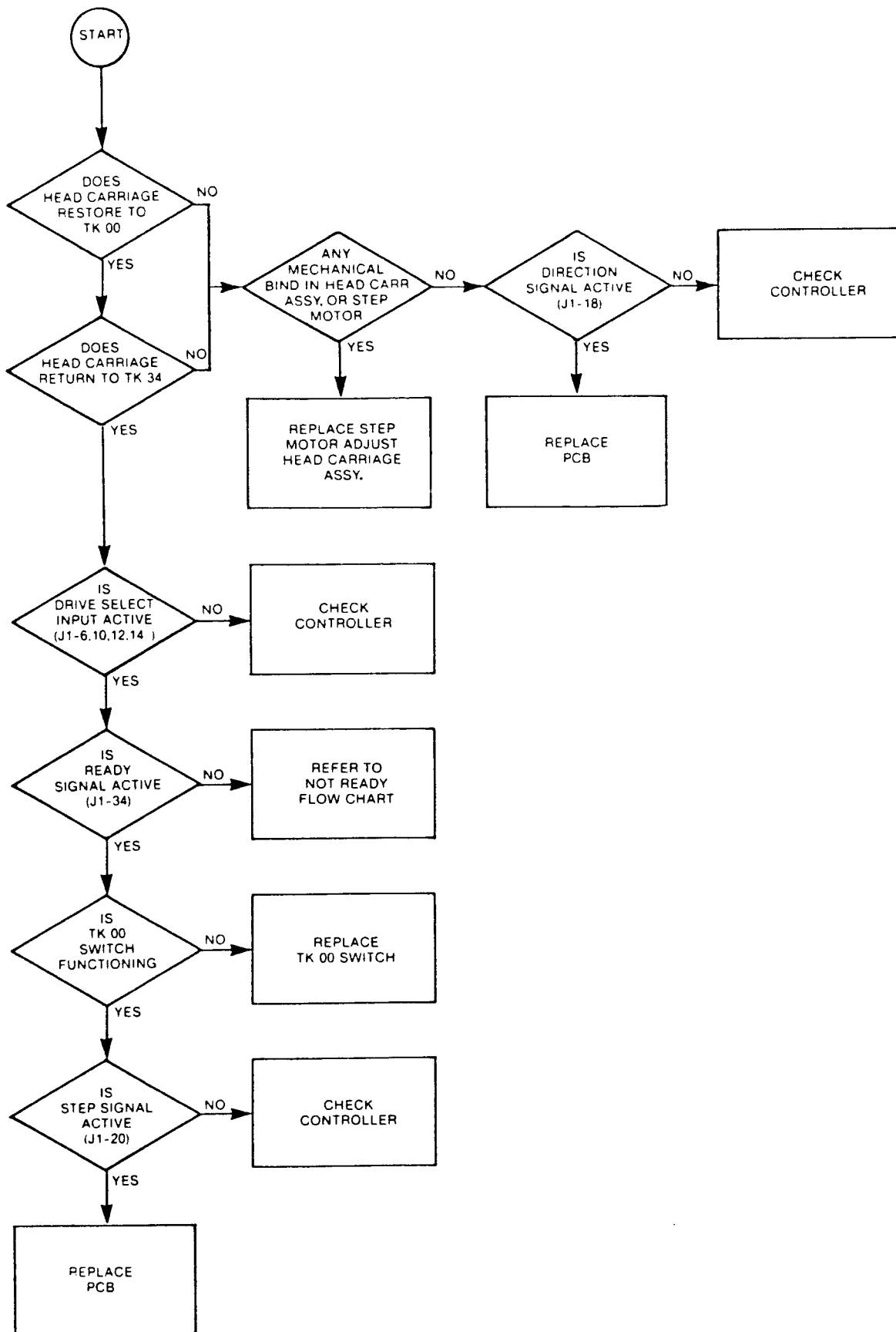

READ ERROR

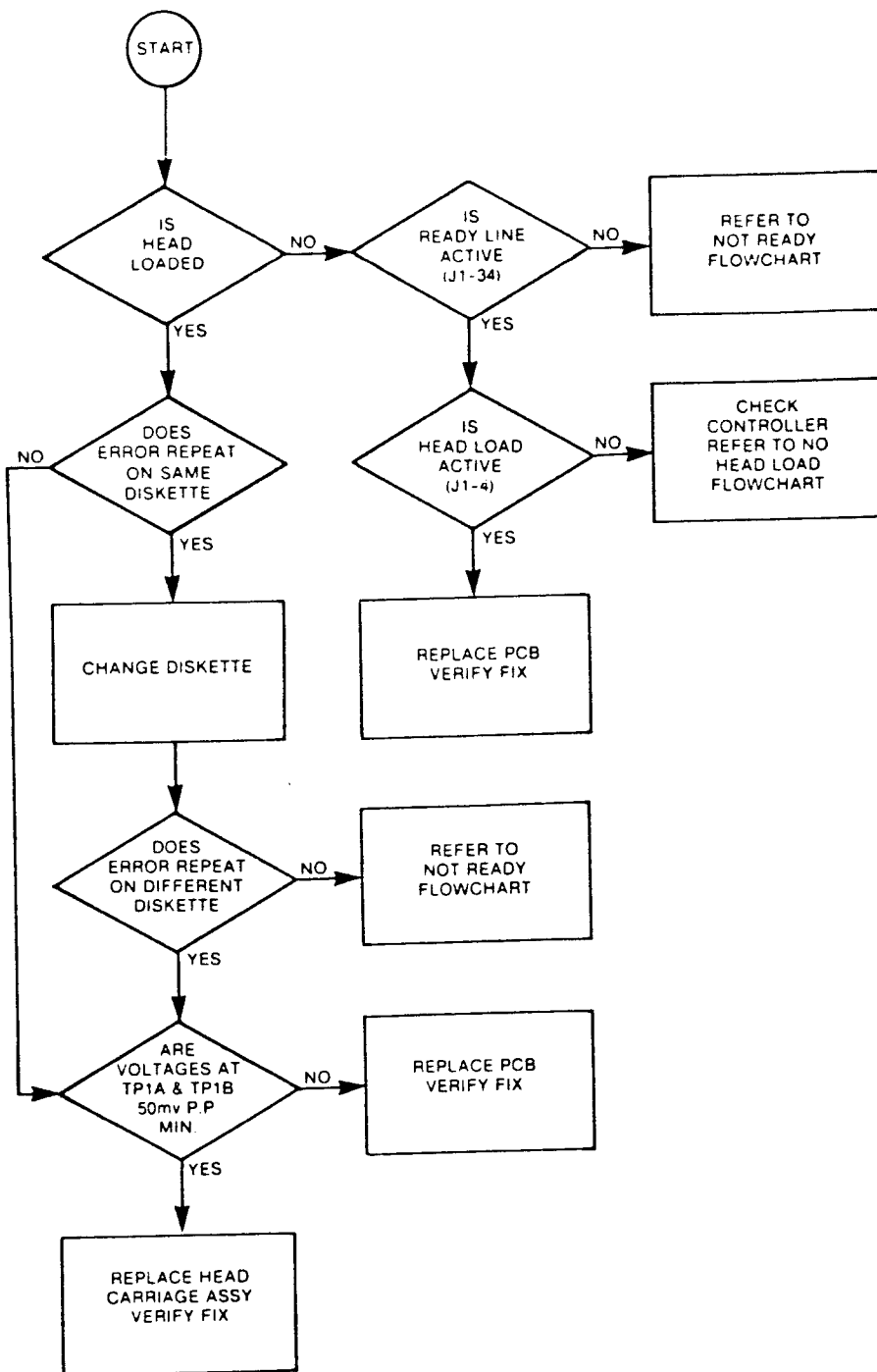

WRITE ERROR

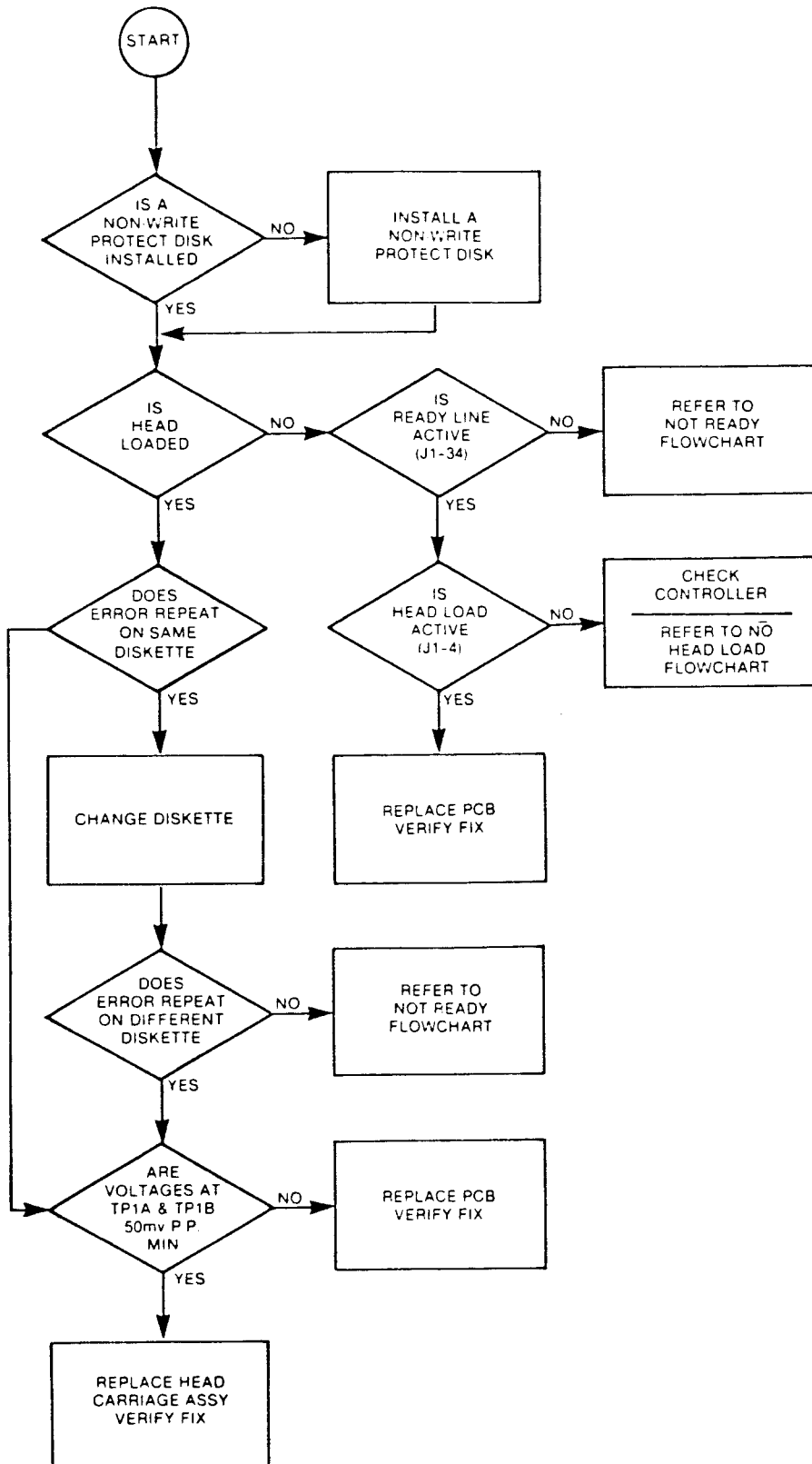

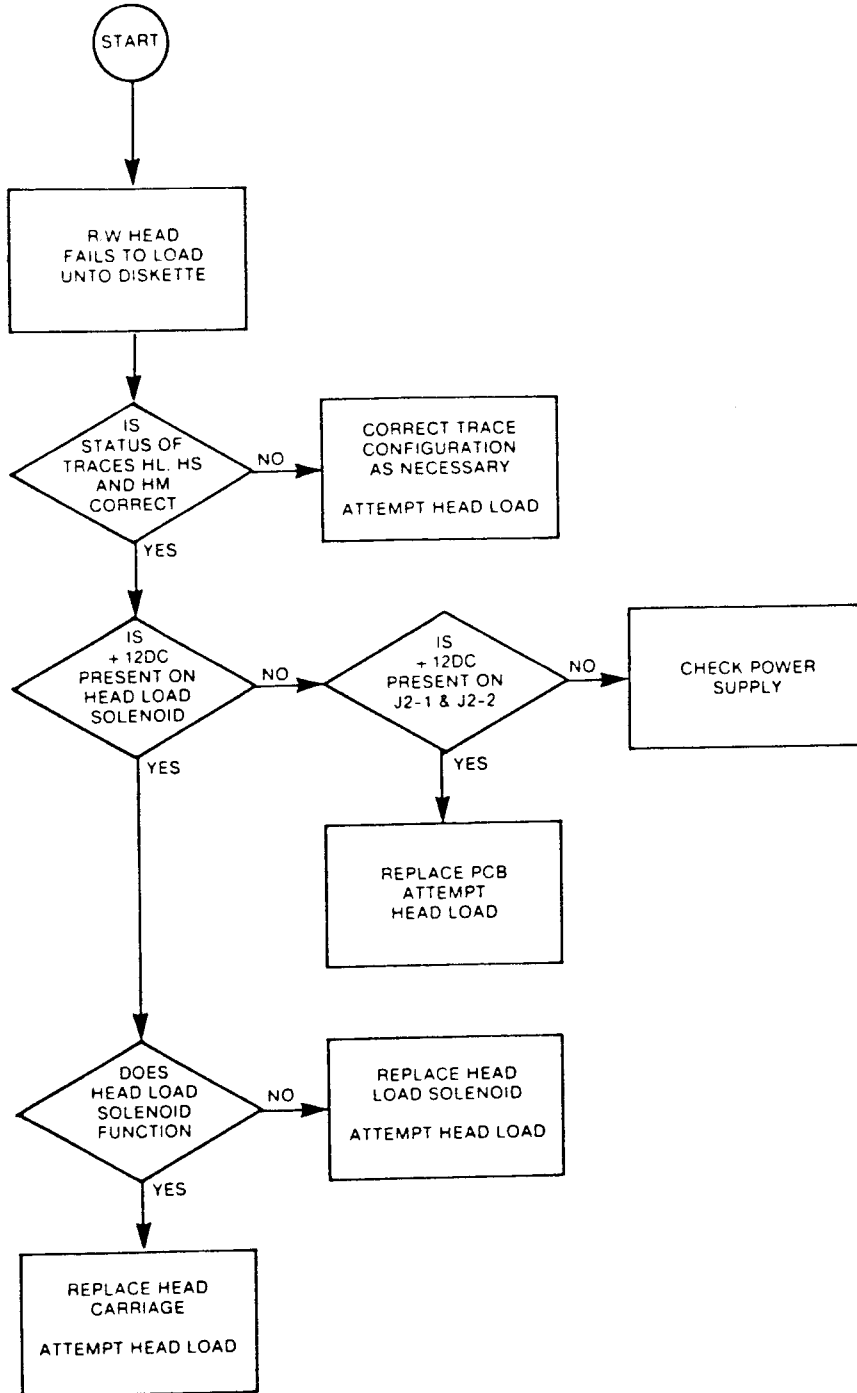

RECOMMENDED SPARE PARTS - FIELD LEVEL

DESCRIPTION	P/N	NUMBER OF DISK DRIVES			
		10	50	100	500
		NUMBER OF SPARE PARTS			
Stepper Motor Assembly	51126-01	1	1	2	2
Drive Motor	51079-01	1	1	1	2
Motor Control Board Assembly	51082-01	1	1	1	2
Printed Circuit Board	51004-01	1	2	4	6
Head Carriage Assembly	51017-01	1	3	6	8
Steel Ball	51009-01	2	4	8	12
Fur Felt	51014-01	2	4	8	12
Head Load Solenoid Assembly	51087-01	1	2	2	3
Spindle Drive Belt	51086-01	1	2	4	6
In Use LED assembly	51116-01	1	1	2	2
Index Sensor Assembly	51083-01	1	2	3	3
Index Lamp Assembly	51062-01	1	2	3	3
Track 00 Switch	51110-01	1	2	4	8
Screw	55173-06	5	10	20	30
Screw	55173-08	5	10	20	30

RECOMMENDED SPARE PARTS - DEPOT LEVEL

(INCLUDES THOSE ITEMS LISTED AS FIELD LEVEL SPARES IN ADDITION TO THE FOLLOWING)

DESCRIPTION	P/N	NUMBER OF DISK DRIVES			
		10	50	100	500
		NUMBER OF SPARE PARTS			
Fur Felt	51014-01	2	8	15	20
Retainer	51013-01	1	1	1	2
Plate Spring	51012-01	1	1	4	4
Steel Ball	51009-01	2	8	16	20
Write Protect Lamp Assembly	51036-01	1	2	3	3
Write Protect Sensor Assembly	51048-01	1	2	3	3
Motor Control Board Assembly	51082-01	1	2	3	3
Screw	55173-06	5	10	20	30
Screw	55173-08	5	10	20	30
Screw	55173-12	5	10	20	30
CE Diskette	51197-01	1	2	2	4

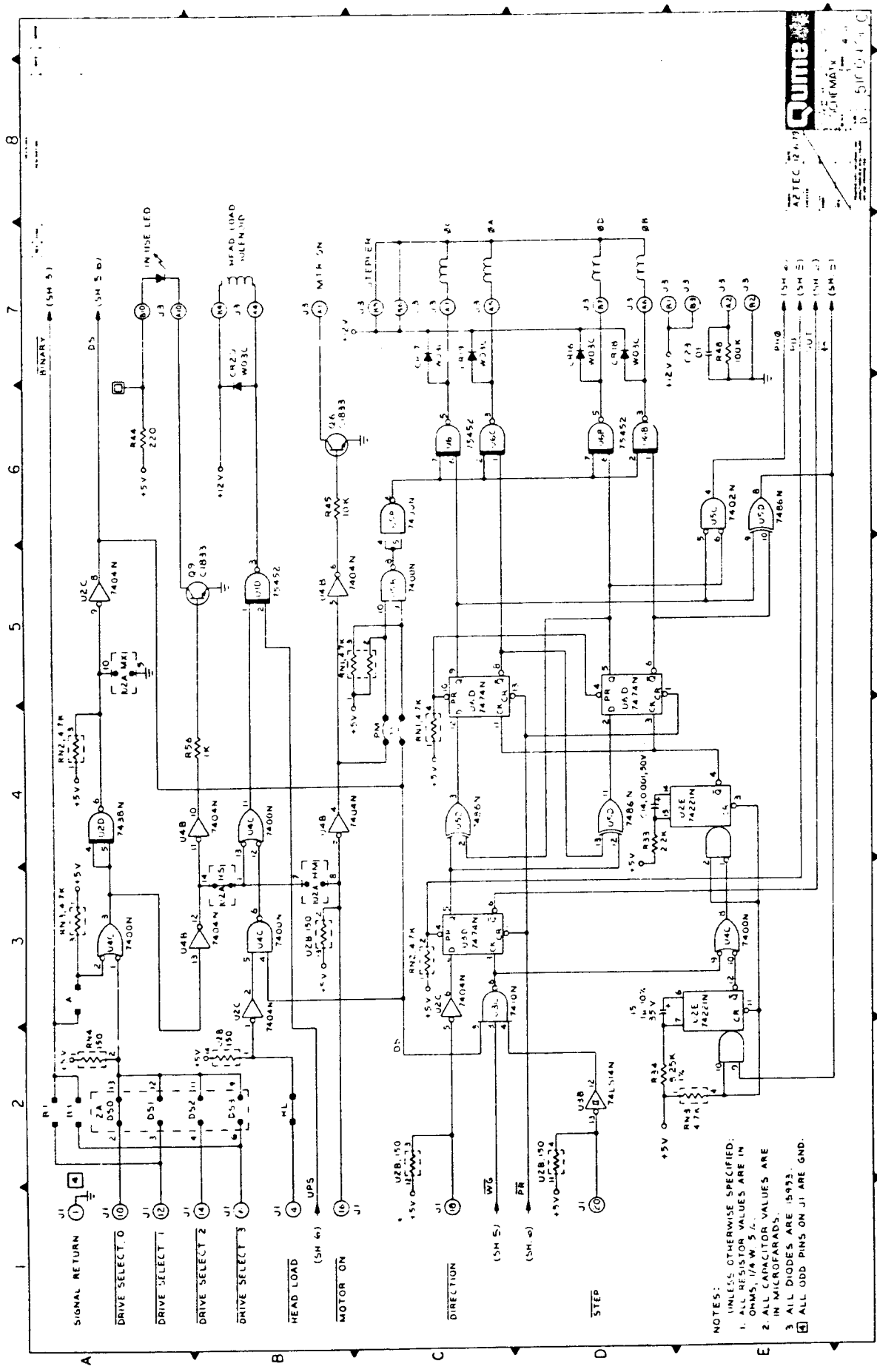

NOTES:
 UNLESS OTHERWISE SPECIFIED:
 1. UNLESS OTHERWISE SPECIFIED, ALL RESISTOR VALUES ARE IN OHMS, CAPACITOR VALUES ARE IN MICROFARADS.
 2. ALL CAPACITOR VALUES ARE IN MICROFARADS.
 3. ALL DIODES ARE 1N913.
 4. ALL ODD PINS ON J1 ARE GND.

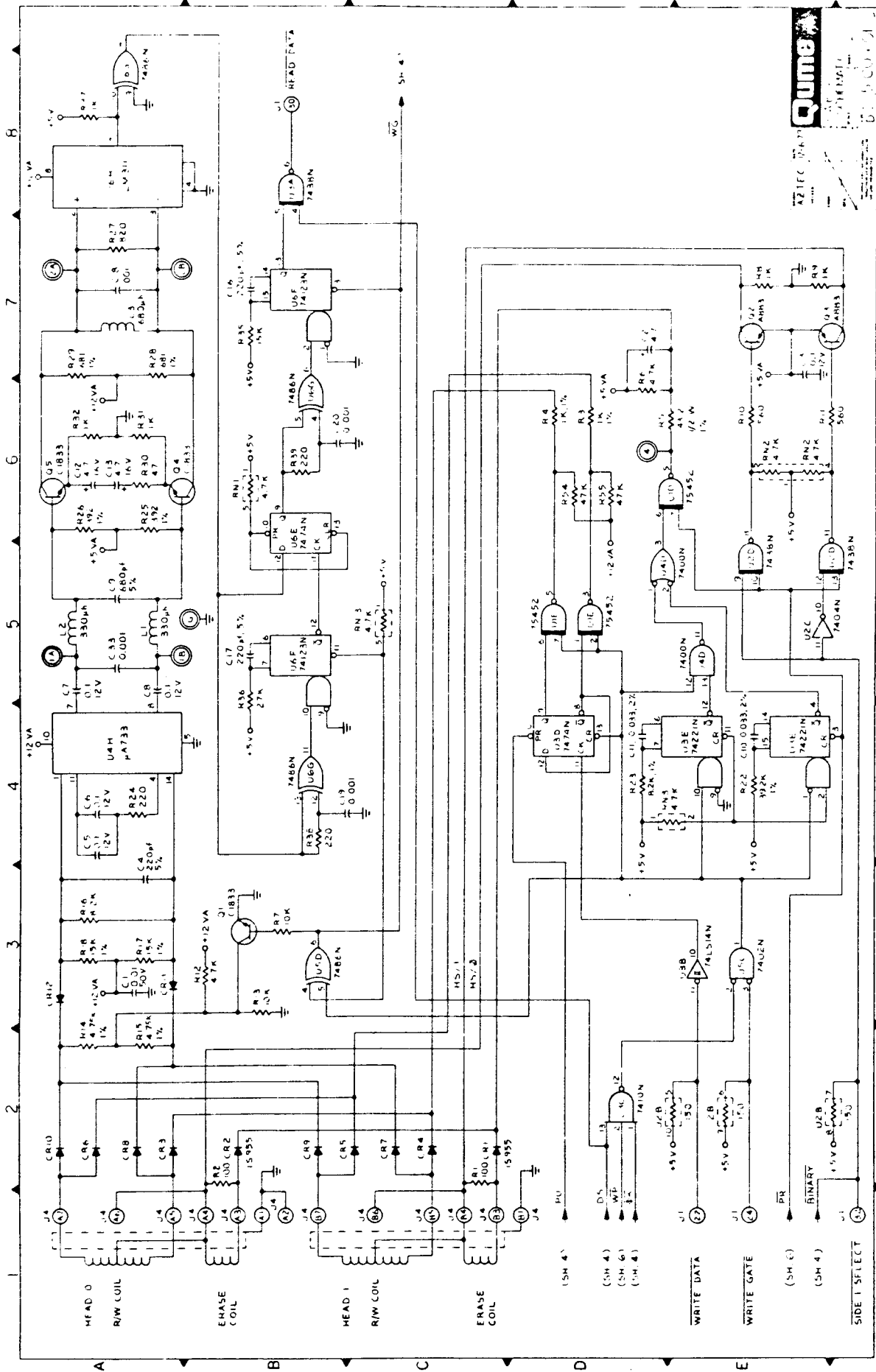

Qume
AZTEC
AZTEC SYSTEMS
1000 UNIVERSITY AVENUE
BERKELEY, CALIF. 94702
TEL: 415/841-3000

INTERCONNECTION DIAGRAM

