

RM

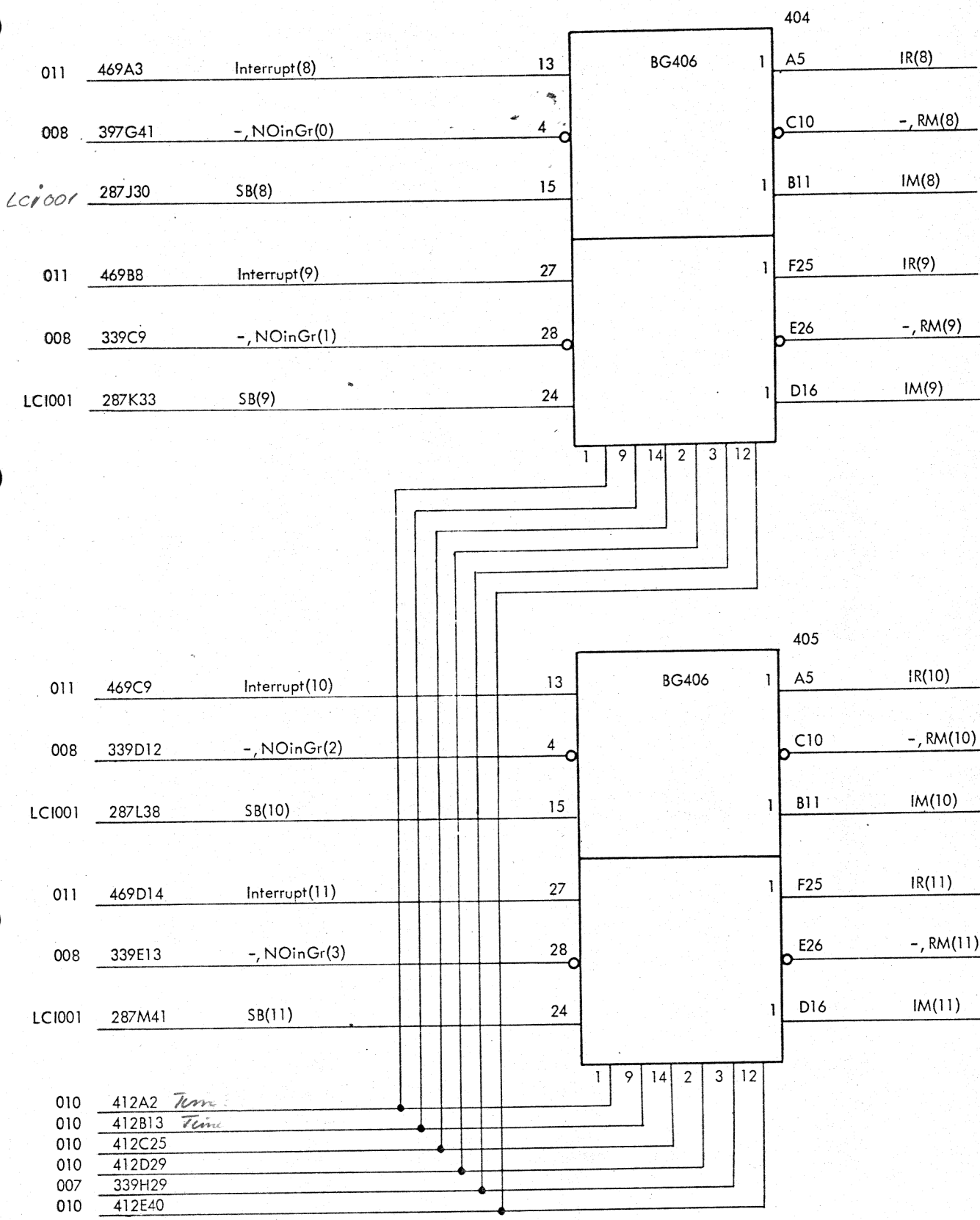

RM

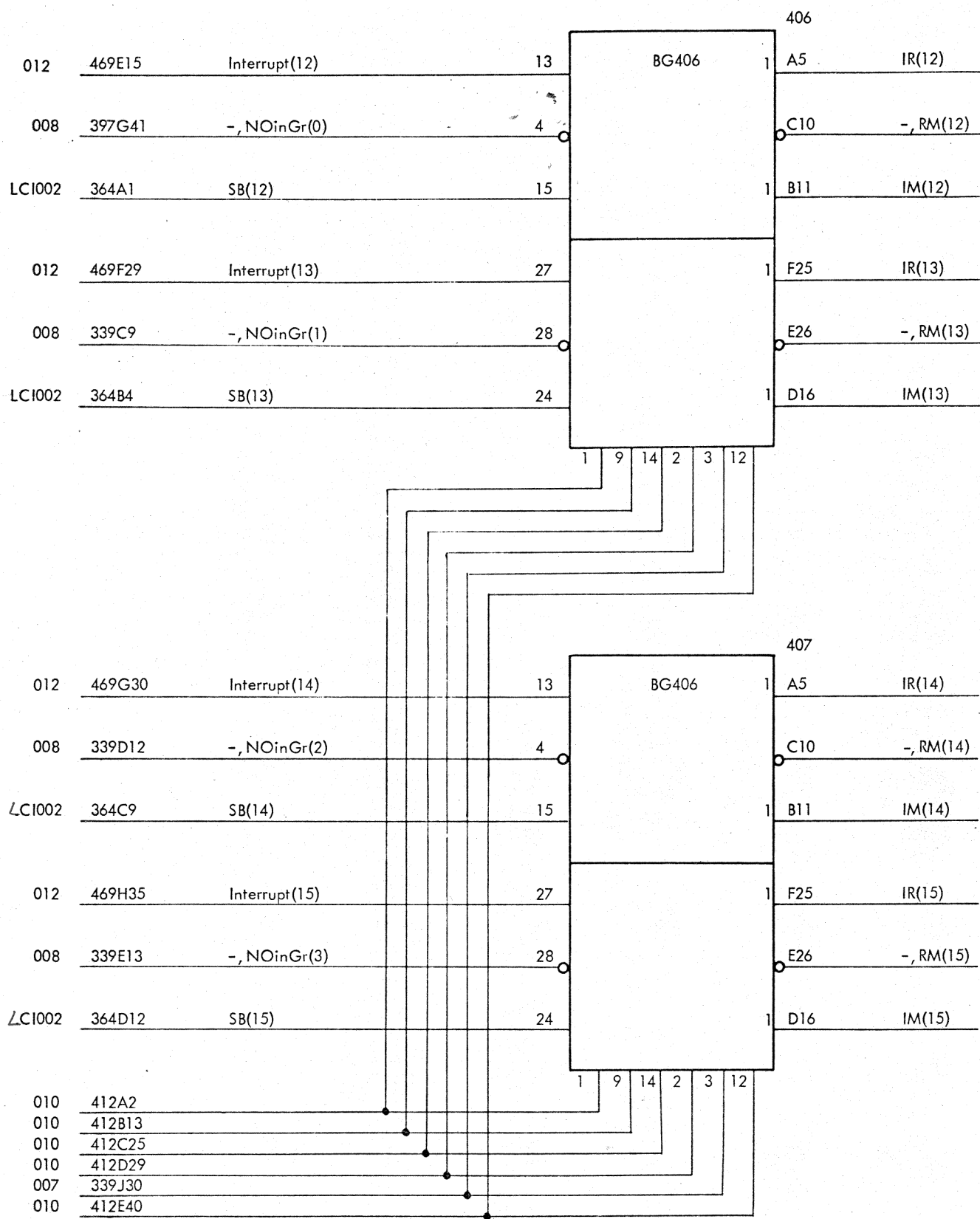

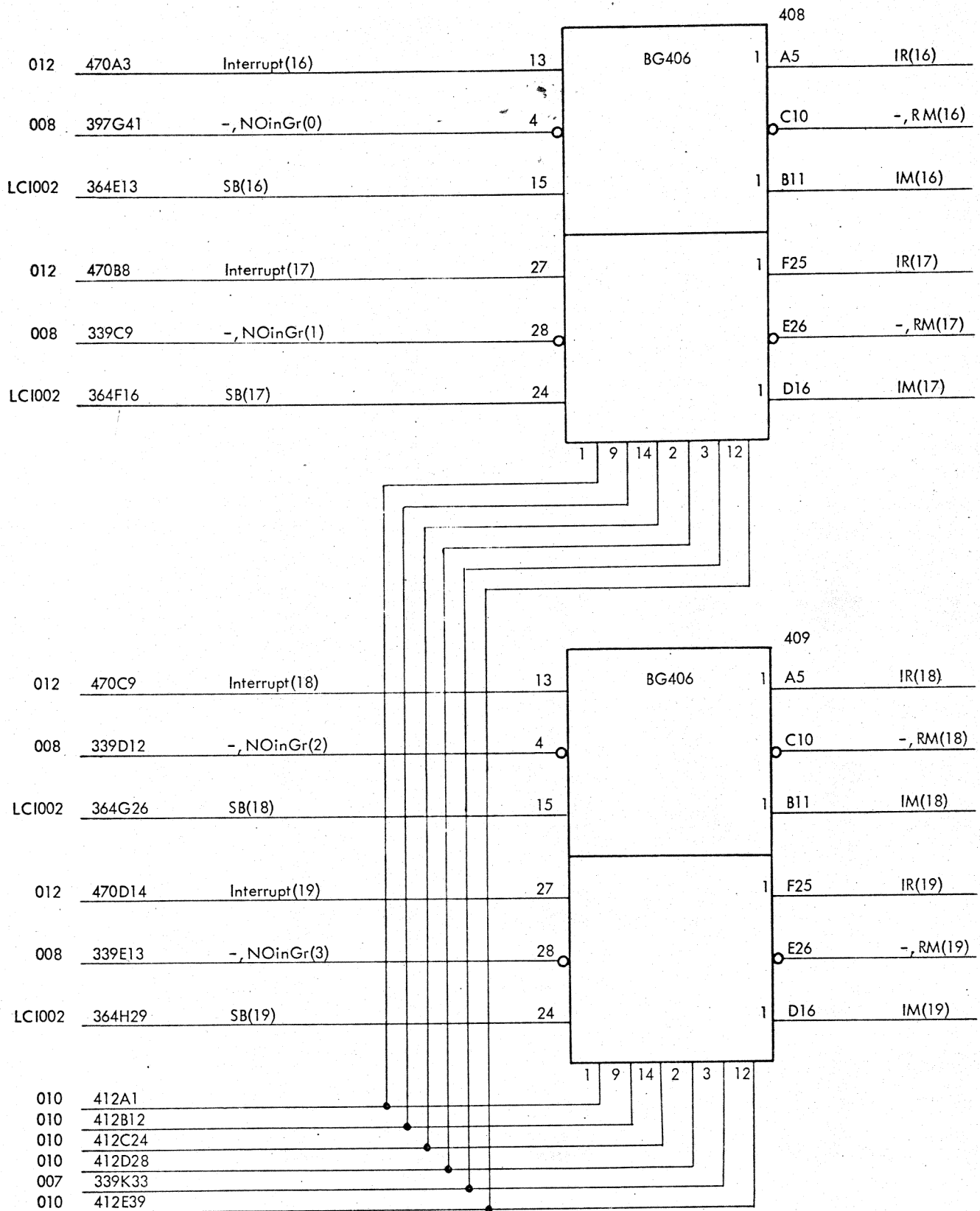

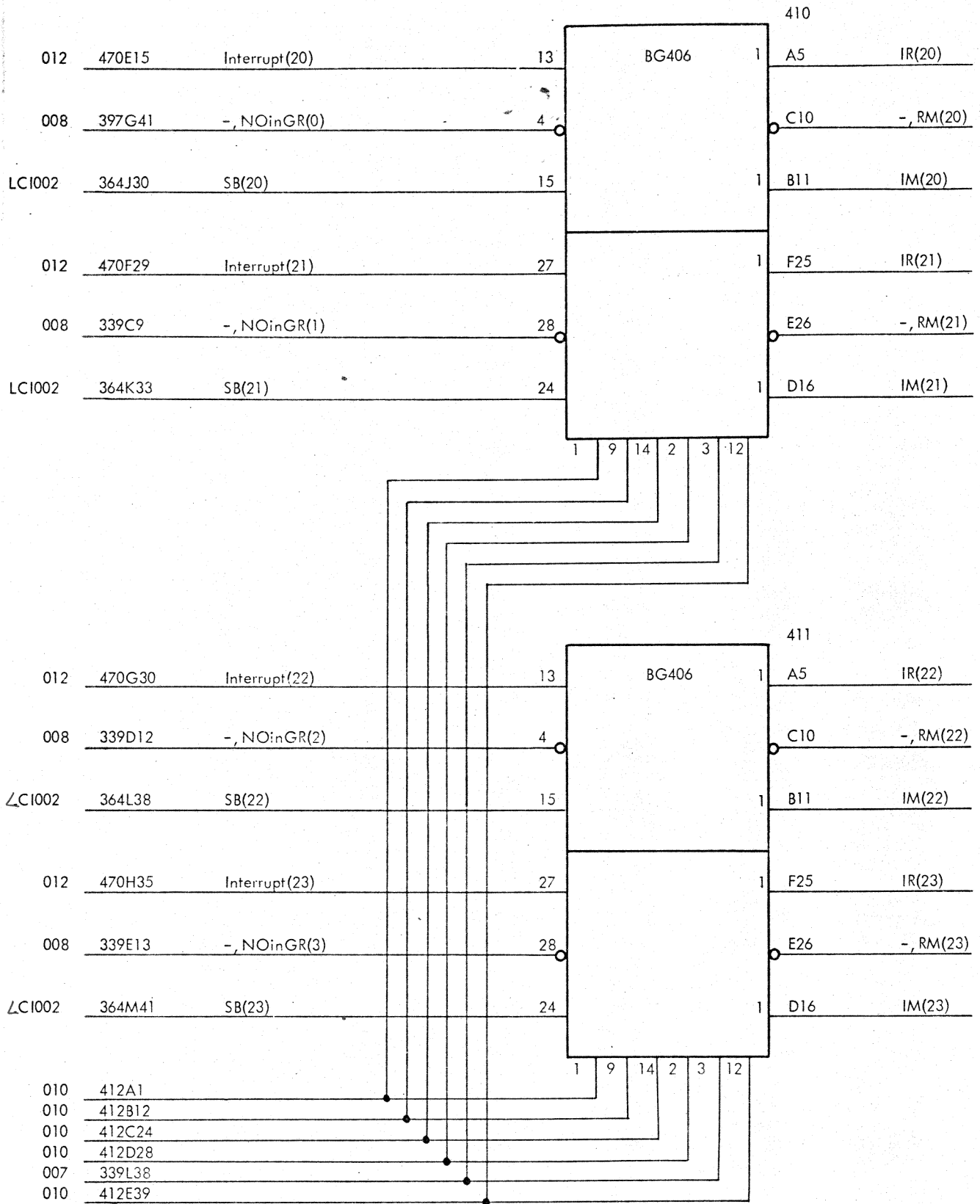

RM

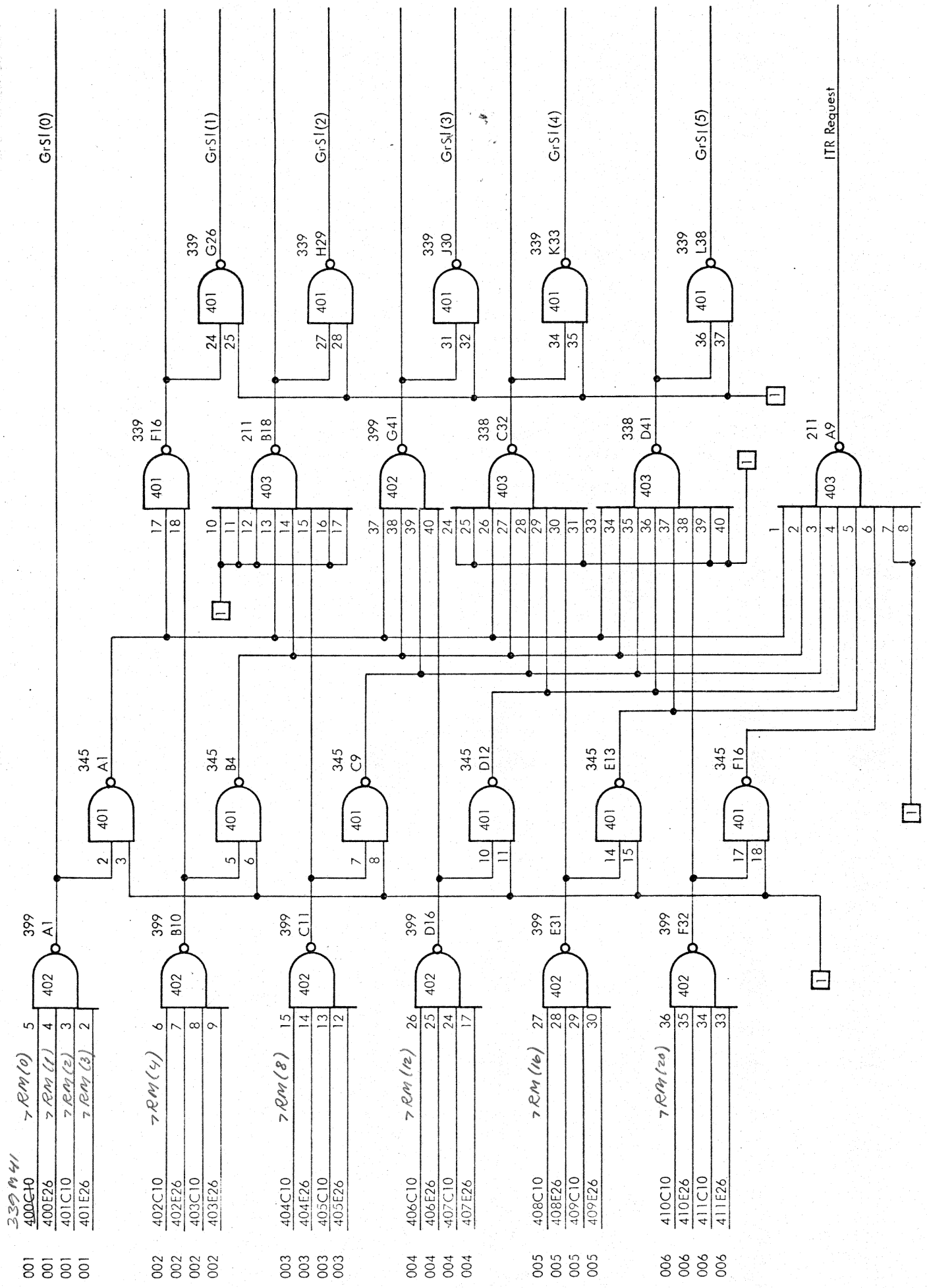

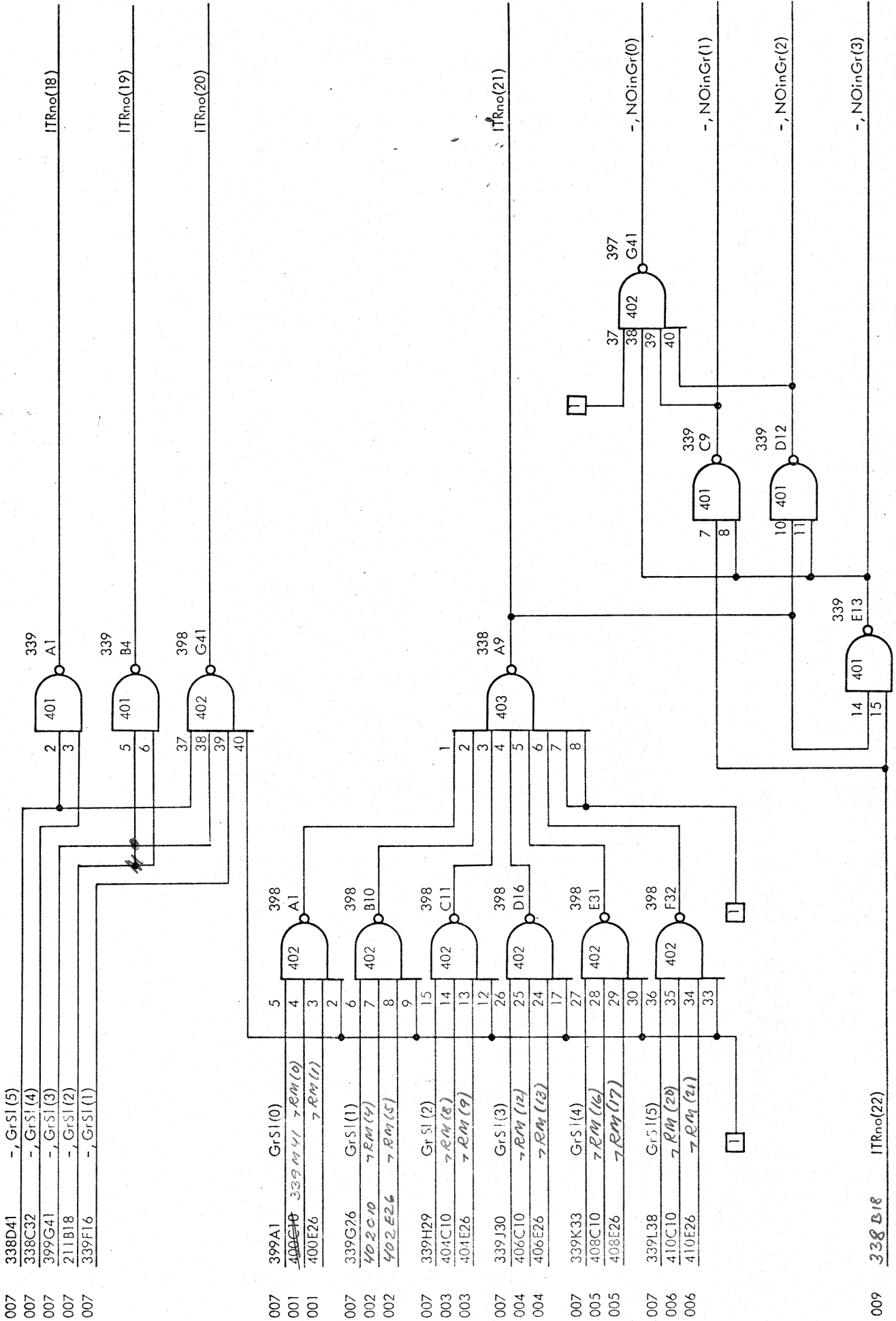

RC4000

ITRno(18:21), NOinGr(0:3)

V10649

Logic Diagram

ITR008



