

RC4000

RPT Cnt, RPT Rdy, and RPT Data (0:2, 5, 10, 11)

VI0463

Logic Diagram

LCI015

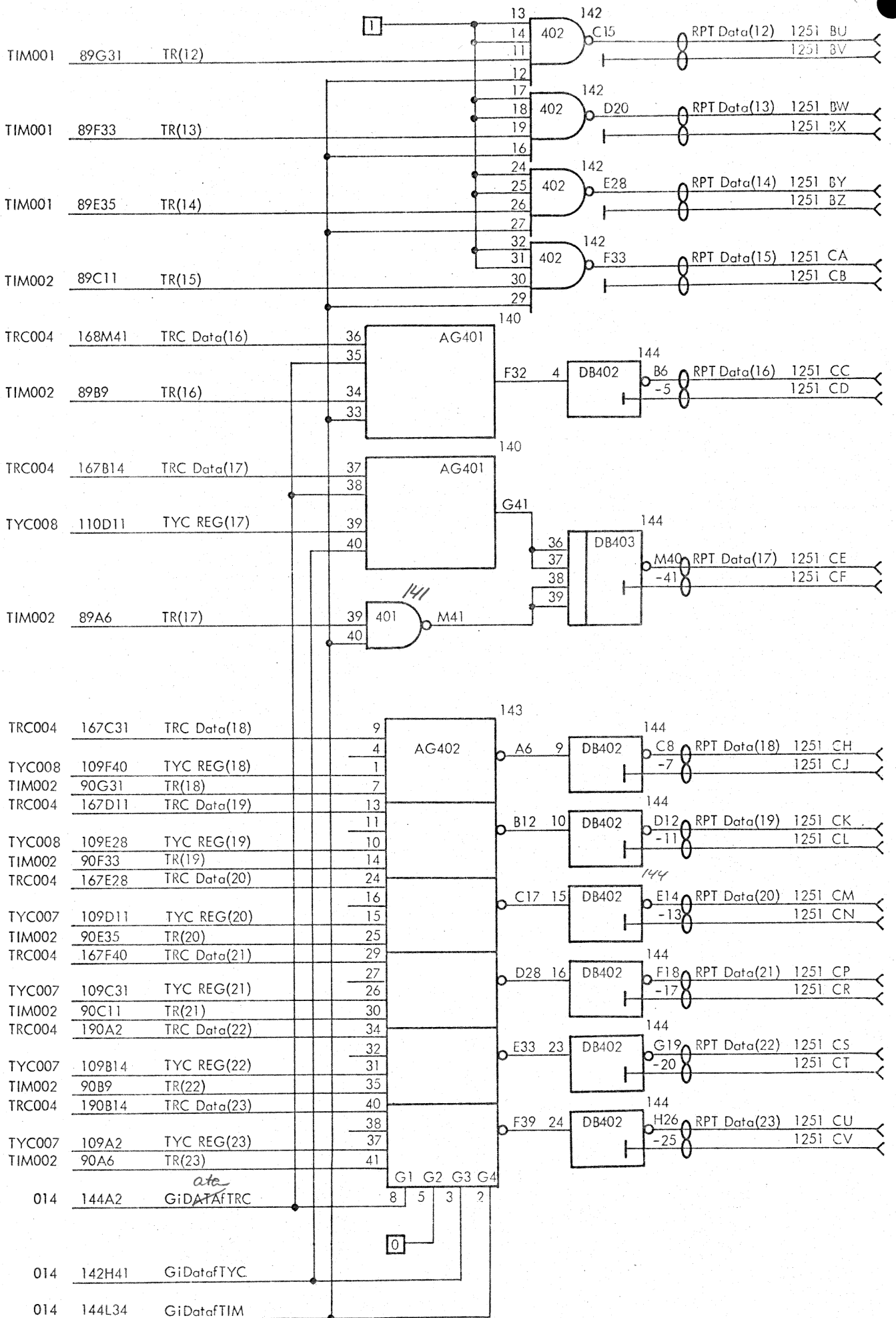

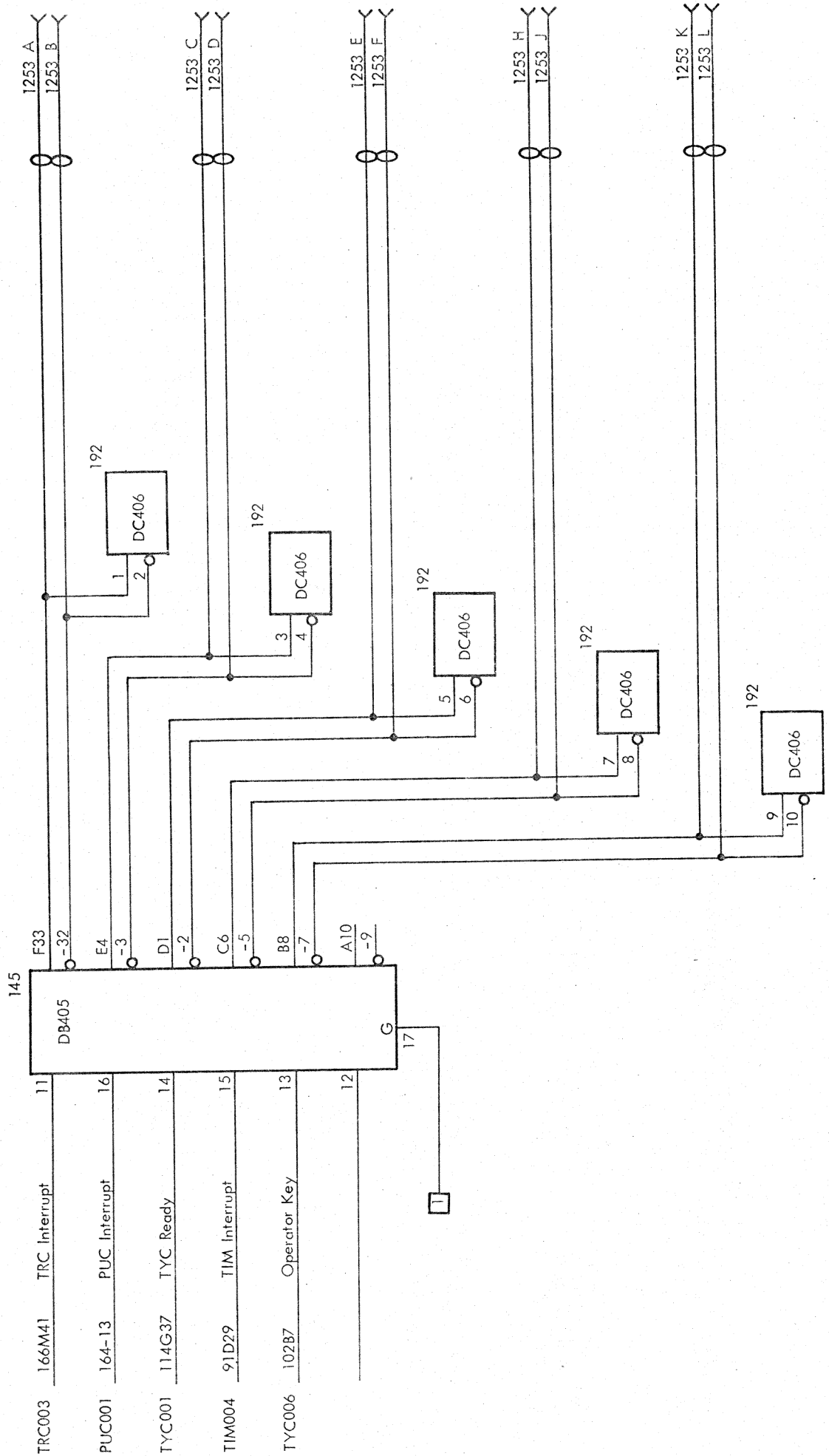

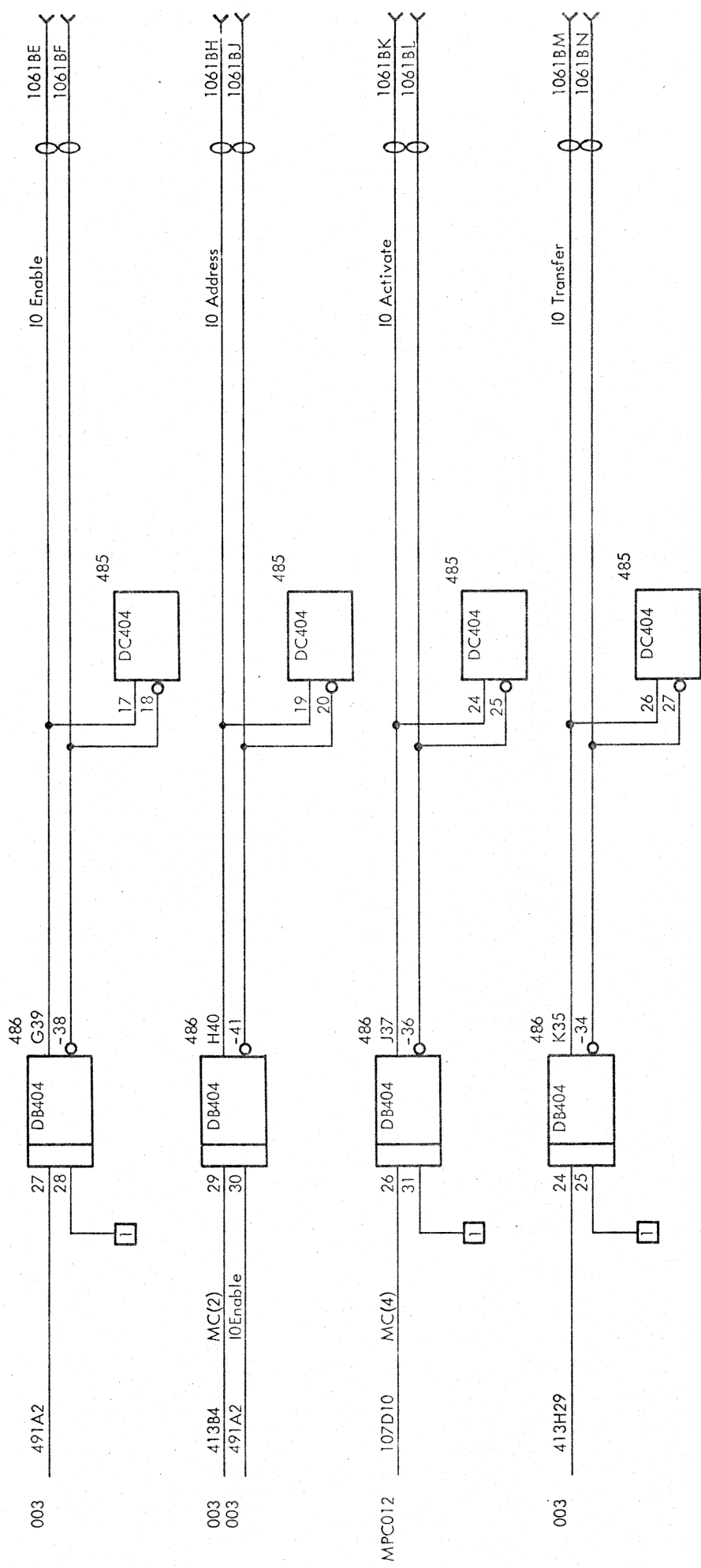

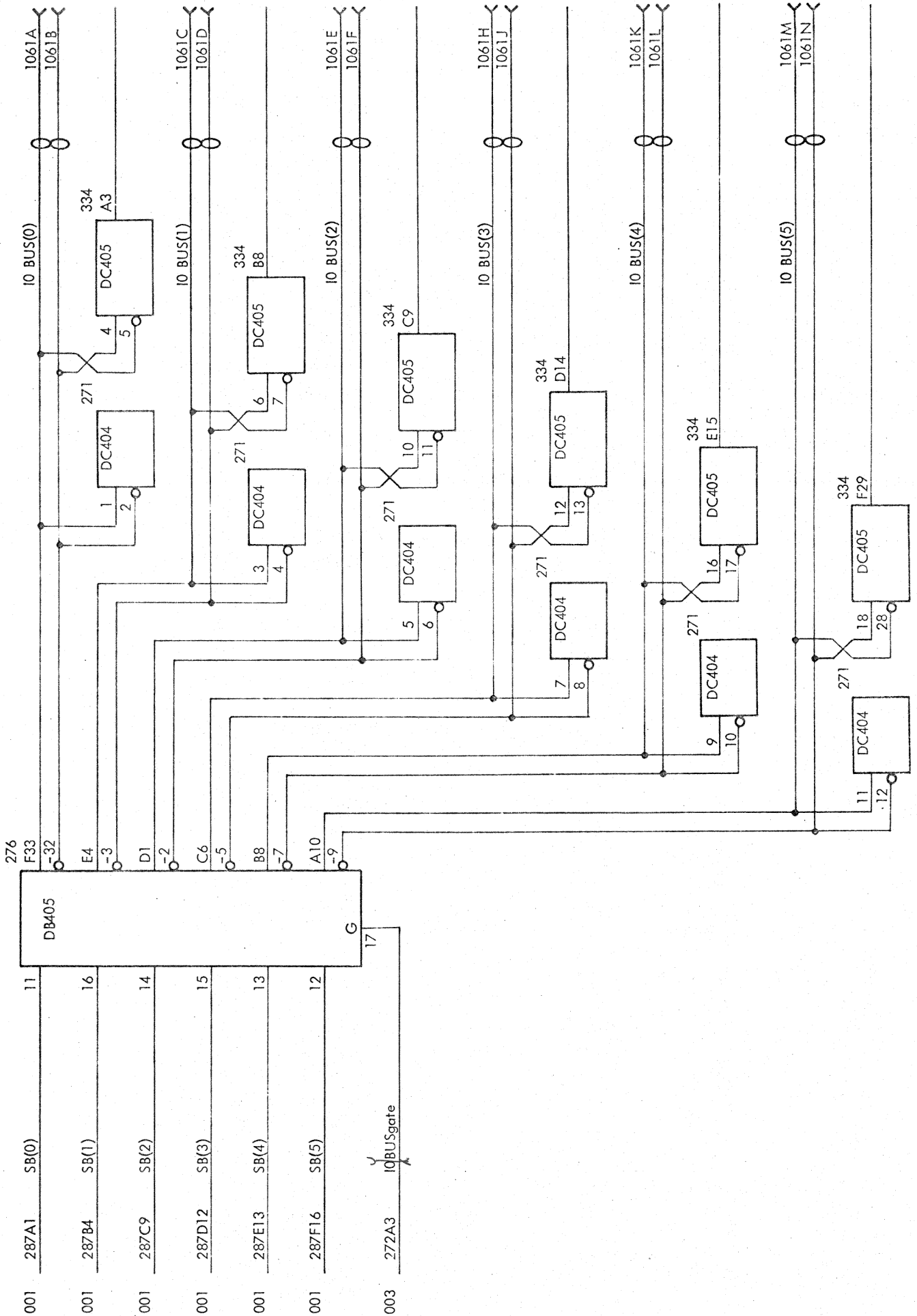



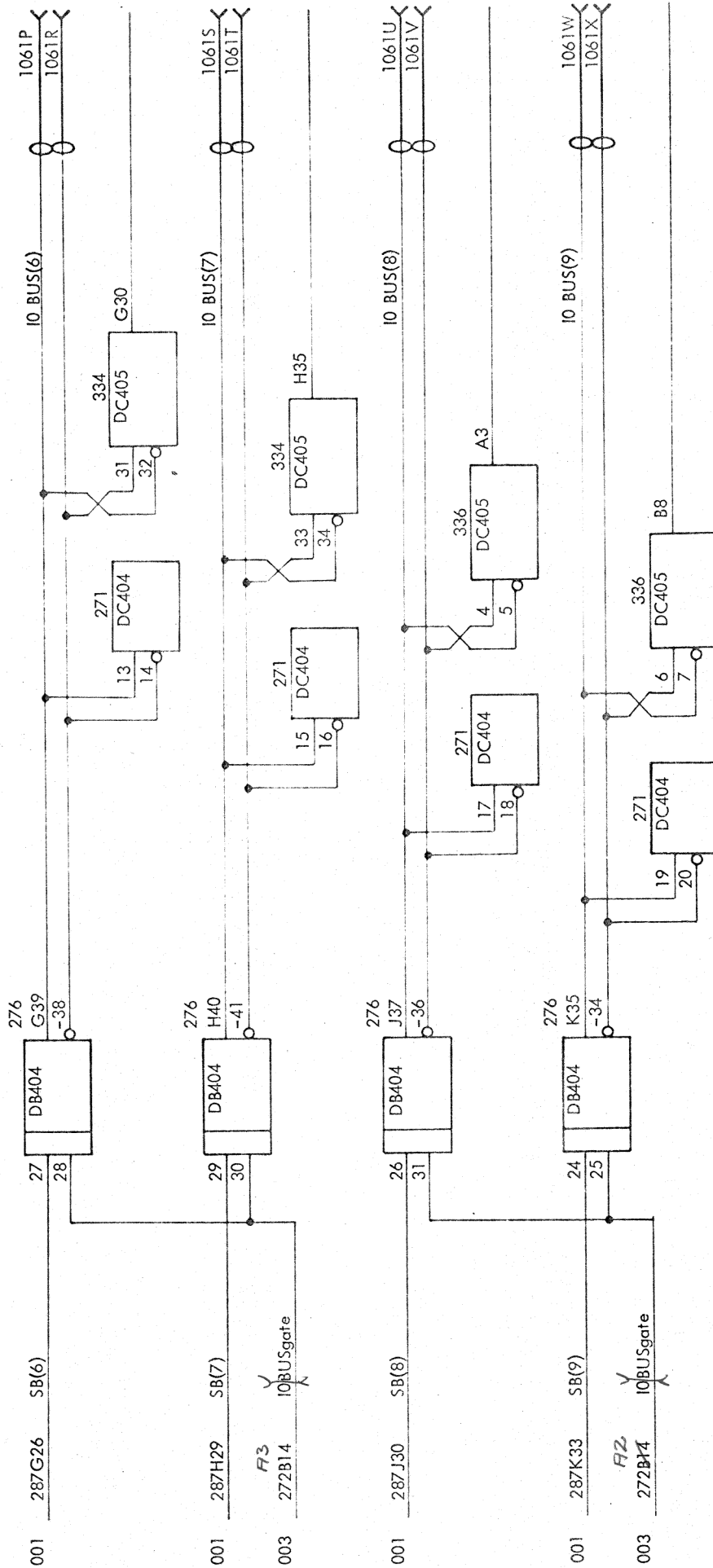

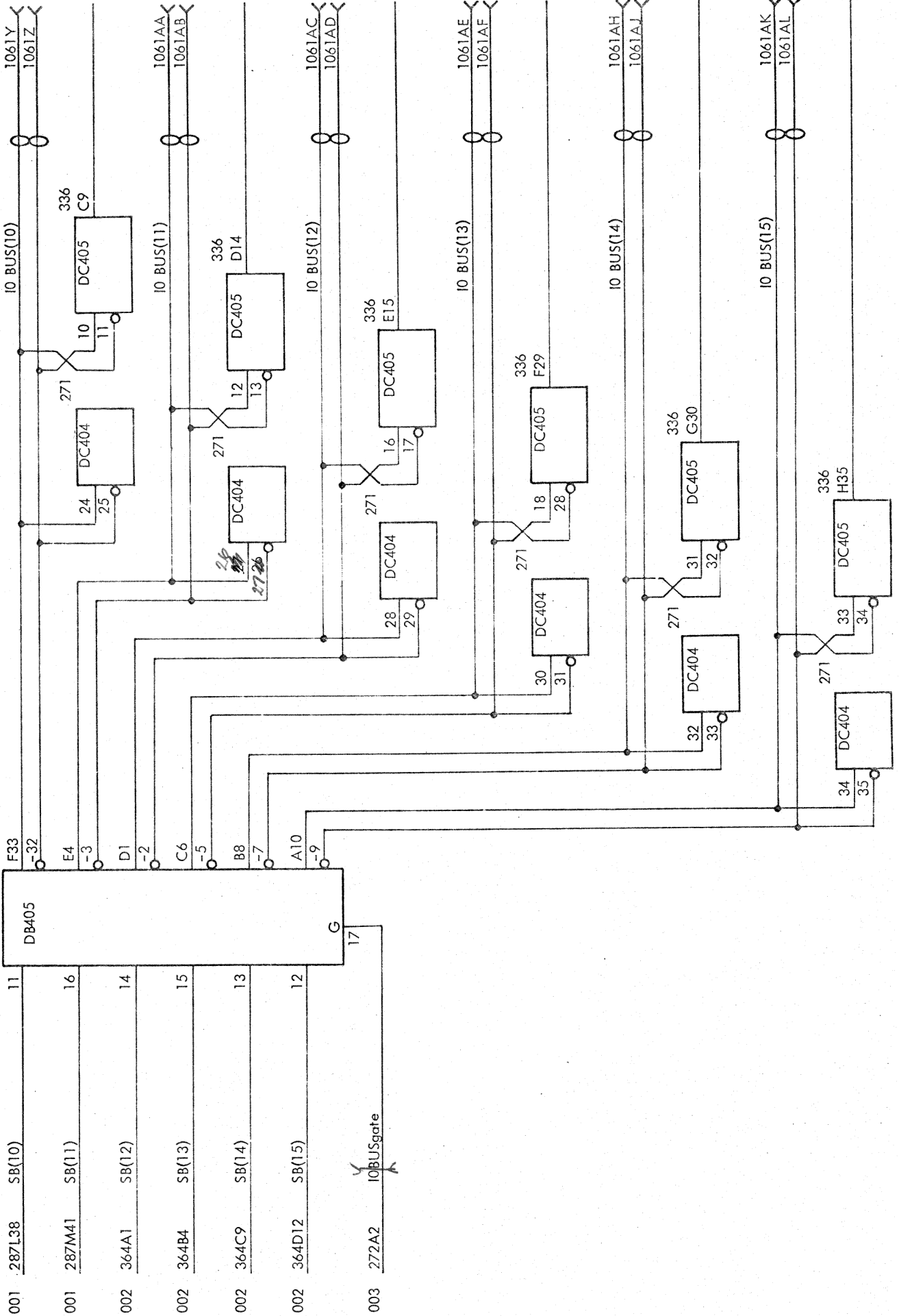

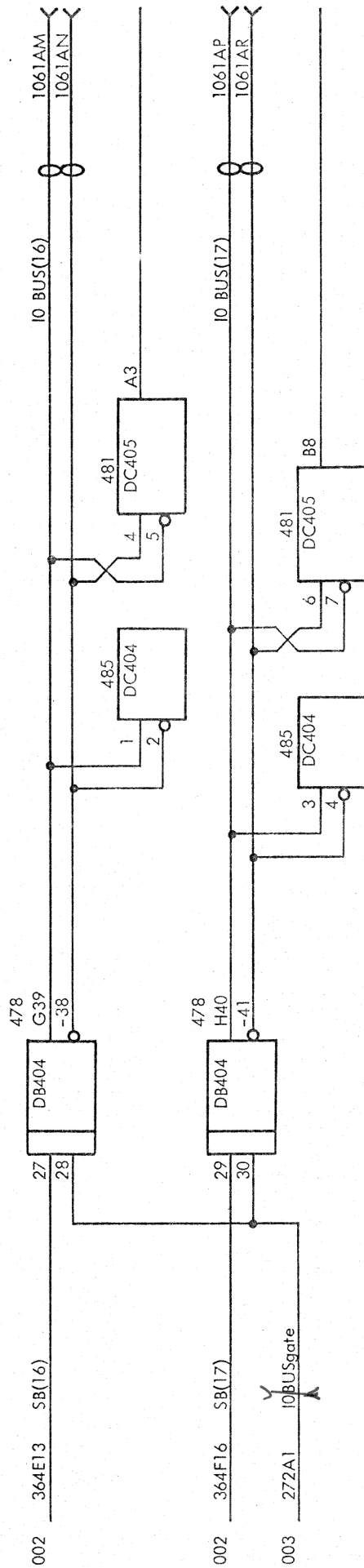

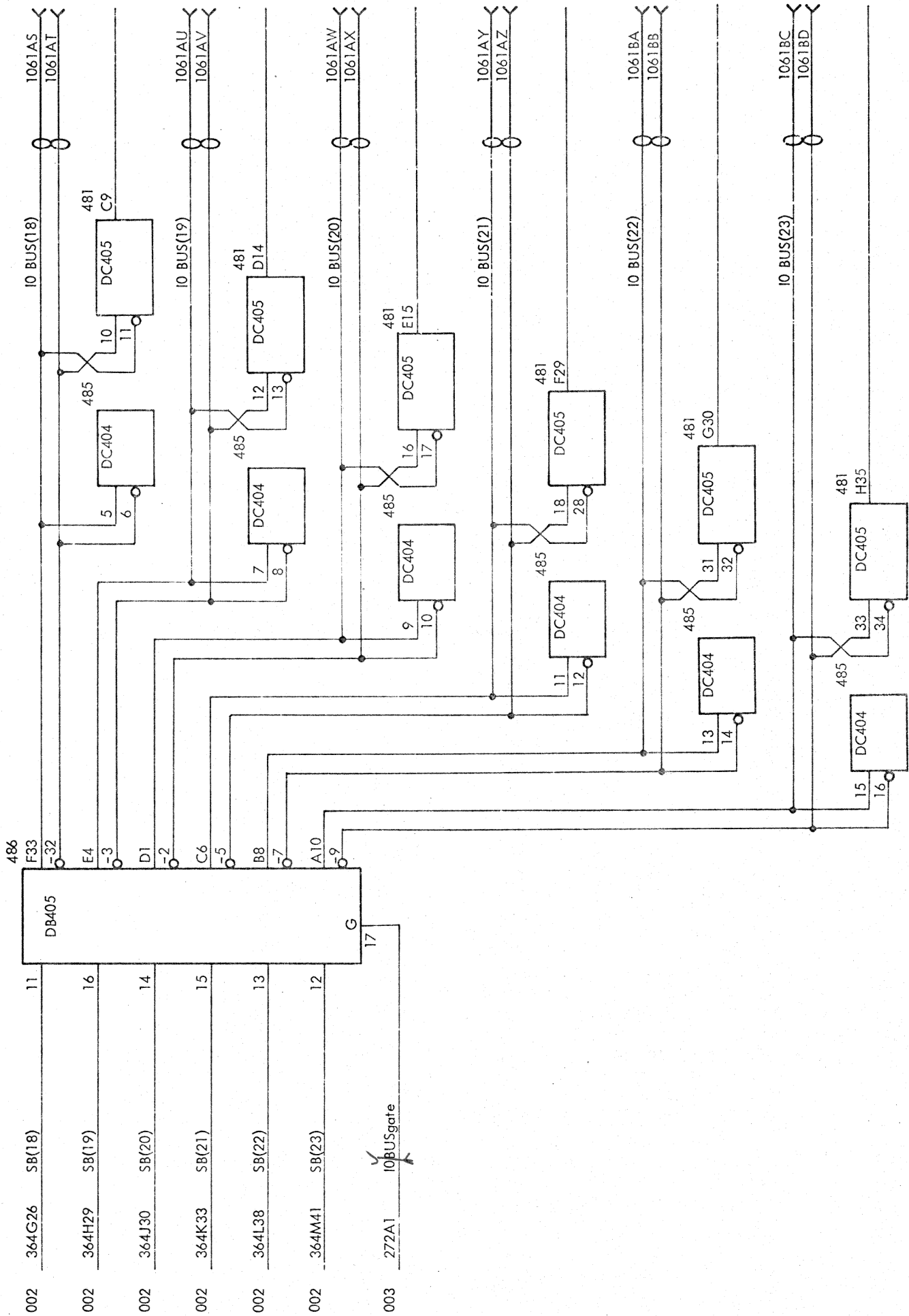

RC4000

IO BUS(18:23) - BUS CABLE 1061

LC1025

V11077

Logic Diagram

