

---

**RCSL No:** 44-RT 1385

**Edition:** February, 1977

**Author:** Mogens Verner Pedersen

---

**Title:**

TECHNICAL MANUAL

MTC 311

---

---

**Keywords:**

RC3600, Magnetic Tape Transport Controller, Wangco.

---

**Abstract:**

This paper contains the drawings and the description of the MTC 311  
Magnetic Tape Controller.

---

Copyright © 1980, A/S Regnecentralen af 1979  
RC Computer A/S  
Printed by A/S Regnecentralen af 1979, Copenhagen

Users of this manual are cautioned that the specifications contained herein are subject to change by RC at any time without prior notice. RC is not responsible for typographical or arithmetic errors which may appear in this manual and shall not be responsible for any damages caused by reliance on any of the materials presented.

CONTENTS

PAGE

---

DESCRIPTION .....	1
DATA PATH in MTC311 .....	2
TIMING OF COMMANDS .....	2
SIGNAL LISTS .....	8
DIAGRAMS .....	10

**This page is  
intentionally left blank!**

DESCRIPTION.

The Magnetic Tape Controller MTC 311 is a controller to the RC3600 computer, which enables the computer to read or write standard 9-track and 7-track magnetic tape. The logical structure for the controller is described in:

RC3600 PERIPHERAL DEVICES  
MTC 304 MAGNETIC TAPE SYSTEM  
REFERENCE MANUAL  
RCSL: 44-RT 503.

There are two main differences between the two controllers MTC304 and MTC311:

1. MTC311 can control Magnetic Tape Transports with tape speeds as high as 75 ips.
2. The Device No. for MTC311 is selected by switches in the controller.

MTC311 is connected to the formatter via the cable CBL 020.

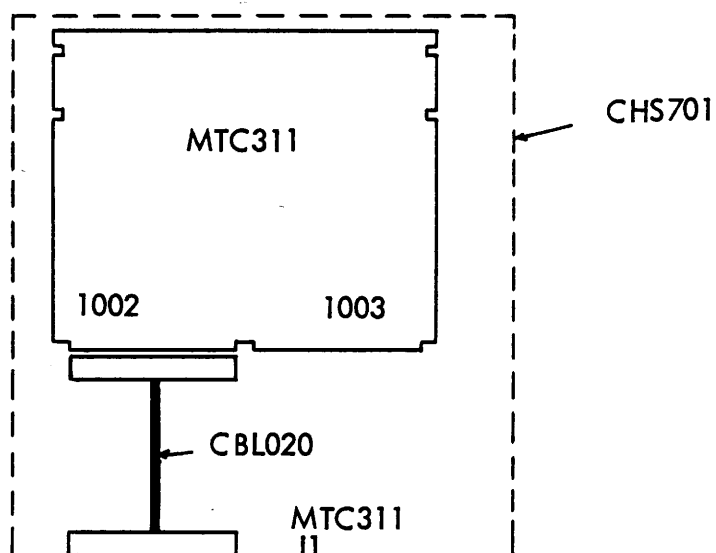

Fig. 1

### DATA PATH in MTC311.

Fig. 2 shows the Data Path in MTC311 and is also a block diagram for the unit. In each block is written the page number showing where in the logic diagrams, each block is drawn.

The timing diagram shown in Fig. 3 shows together with the diagram in Fig. 2, how the Data Paths are used, when the controller is writing a block.

The timing diagram shown in Fig. 4 shows how the Data Paths are used, when the controller is reading a block.

### TIMING OF COMMANDS.

The timing diagrams on Fig. 5, Fig. 6, Fig. 7 and Fig. 8 show the function of the command register and the conditions for setting and clearing the BUSY and the DONE flip flop.

The circuits are shown on diagram MTC06, MTC07, MTC08 and MTC09.

770136 MVP 770126 A03

Fig. 2 DATA PATH IN MTC311

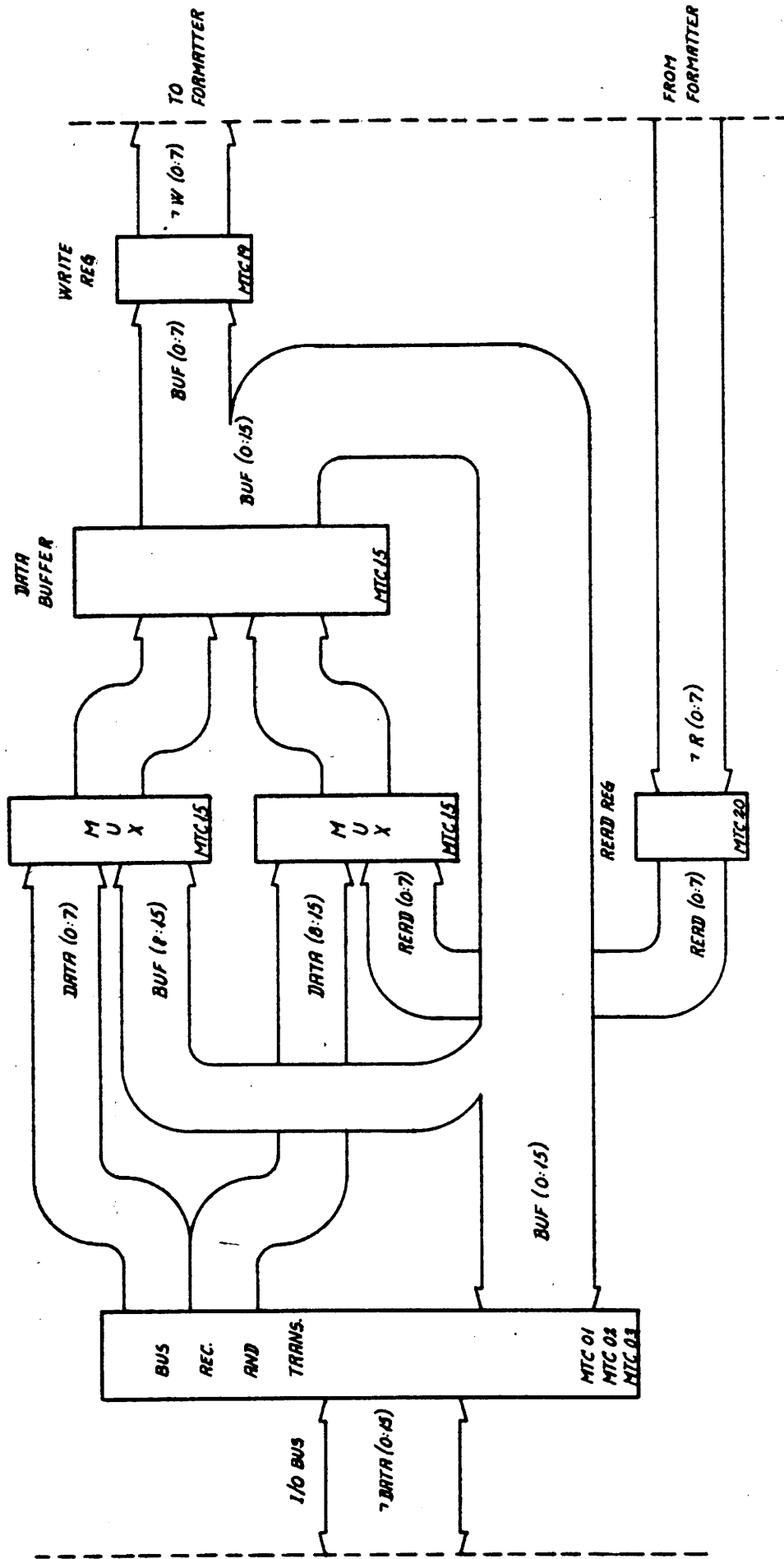

MTC311

R11803

WRITE MTC311 BLOCK WITH 5 CHARACTERS ABCDE

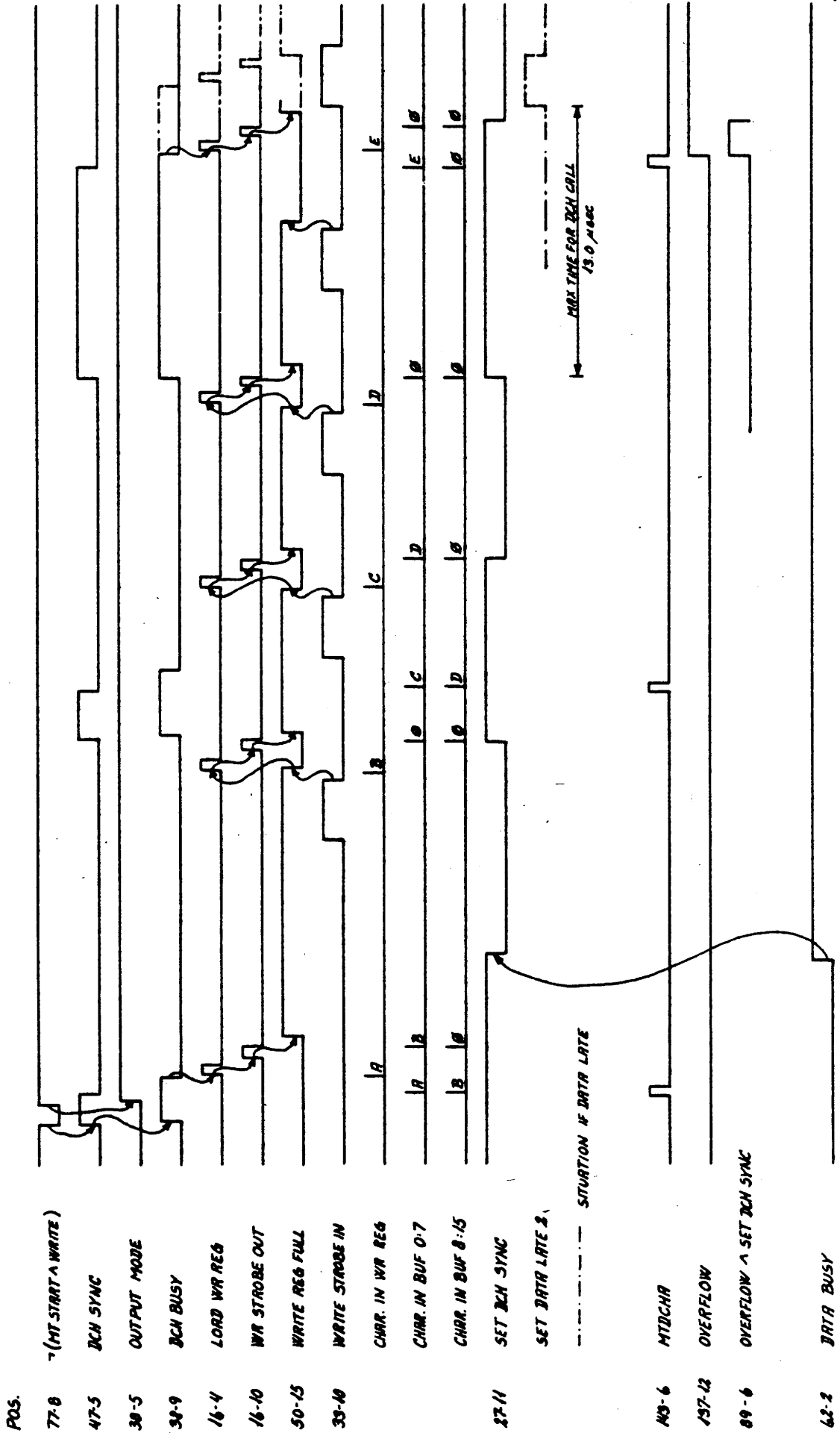

MTC311

R 11802



770126 MVP 770126 A0B

READ MTC311 BLOCK WITH 6 CHARACTERS A B C D E F

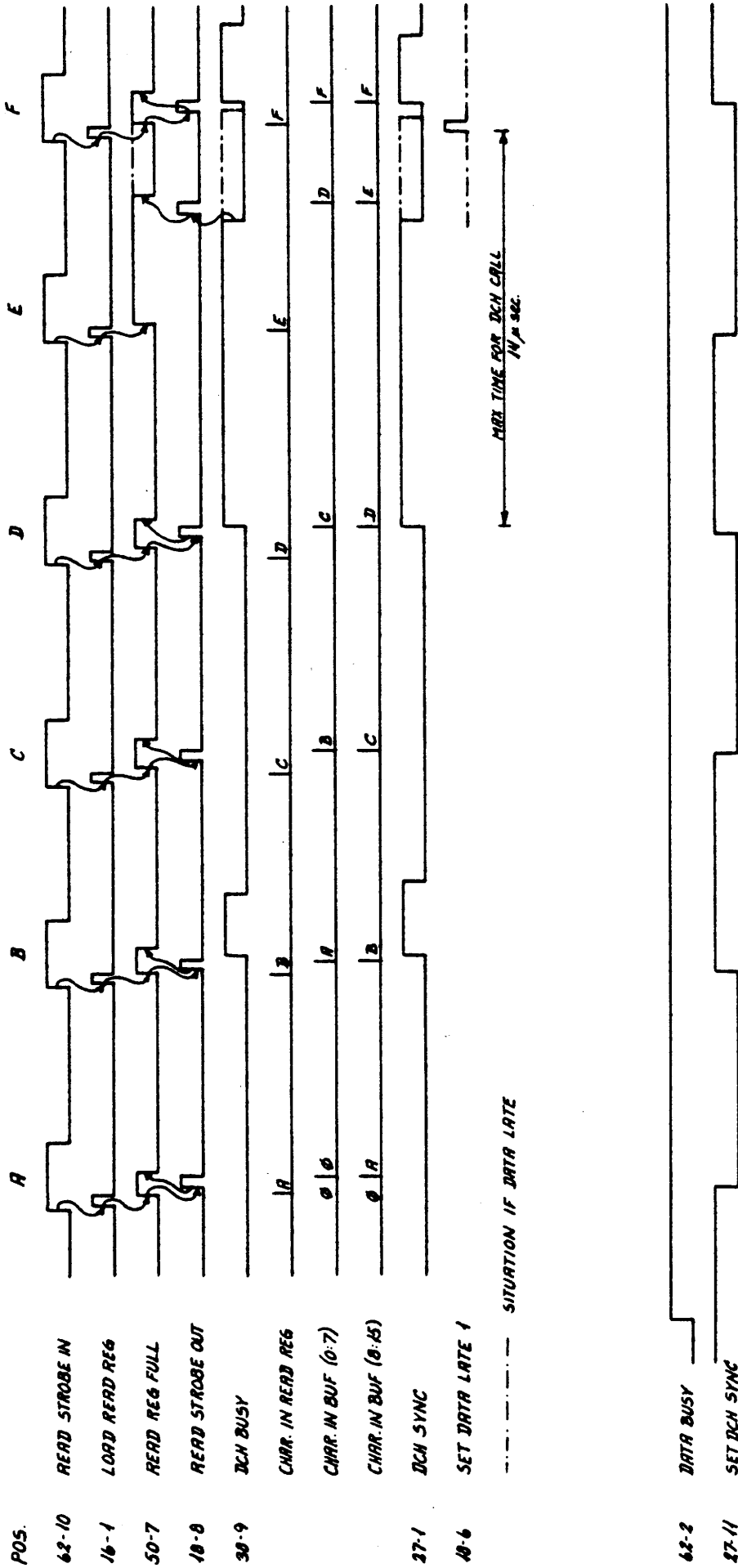

MTC311

R11804

Replaced by Dwg. No. \_\_\_\_\_  
 due to ECN \_\_\_\_\_  
 Replaces Dwg. No. \_\_\_\_\_  
 Design Check \_\_\_\_\_  
 Dwg. Office Check \_\_\_\_\_  
 Drawn by 770126 ROB  
 Designed by 770126 MVP  
**A/S REGNECENTRALEN**

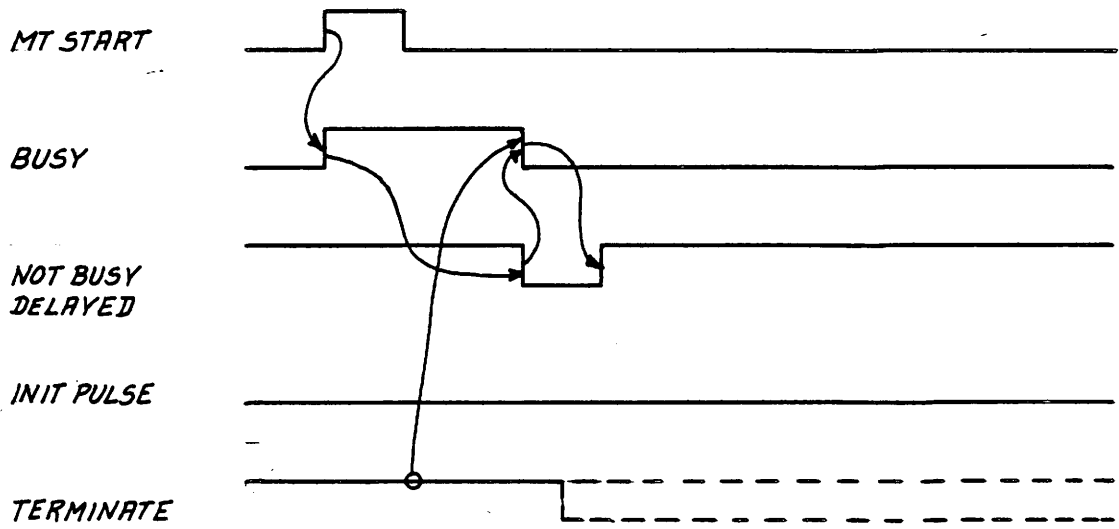

Fig. 5 Timing diagram for the execution of a rejected command.

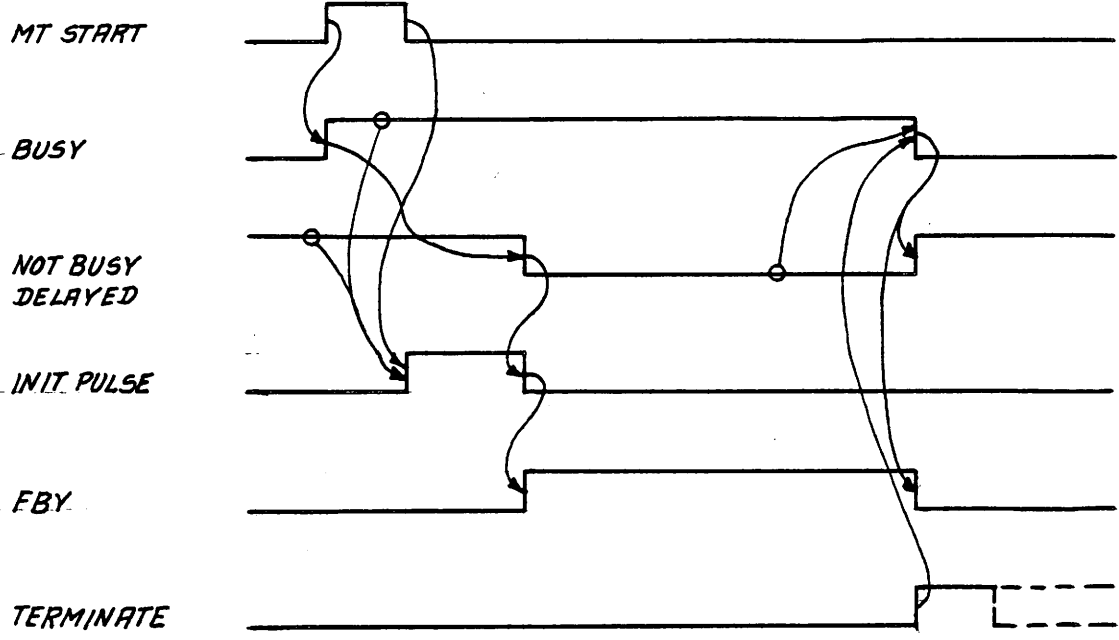

Fig. 6 Timing diagram for an interrupted time consuming operation.

Unit		
Dwg. No.	MTC 311 CENTRAL TIMING TIMING DIAGRAM	

A/S REGNECENTRALEN	Designed by	770126 MVP	Dwg. Office Check	Design Check	Replaces Dwg. No.	due to ECN	Replaced by Dwg. No.
	Drawn by	770126 AOB					

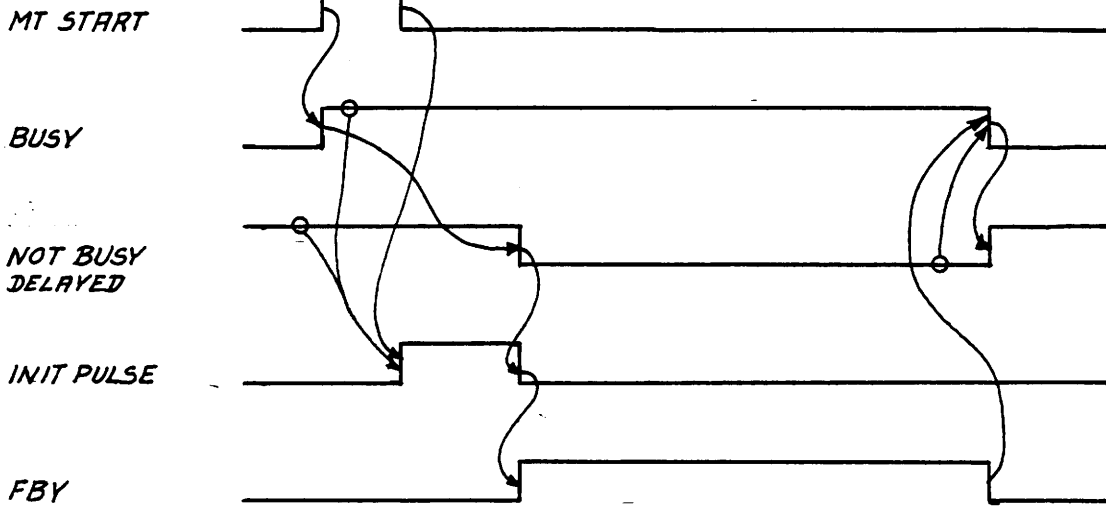

Fig. 7 Timing diagram for the uninterrupted execution of a time consuming operation.

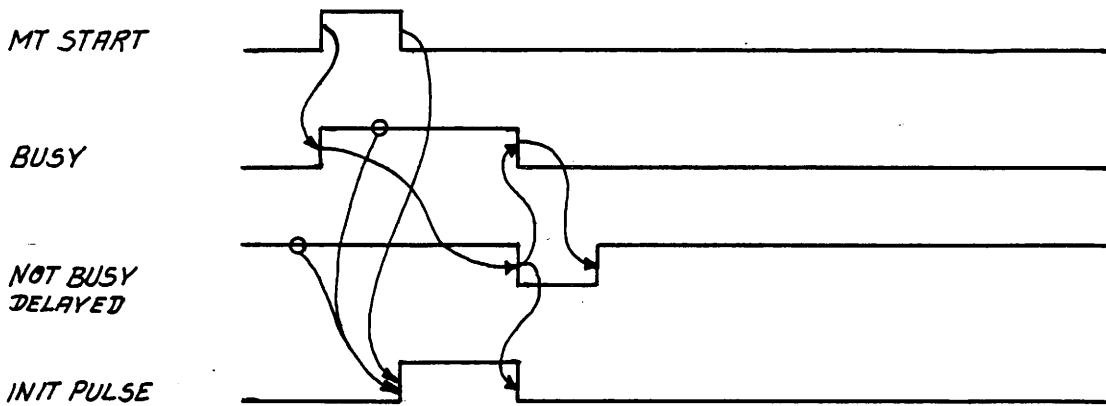

Fig. 8 Timing diagram for the execution of an immediate command.

Unit		
Dwg. No.	MTC 311 CENTRAL TIMING TIMING DIAGRAM	

Connector 1002	Gen. addr.	Signal Name	Connector MTC311-J1
A 1	Out	-, FAD (Formatter addr.)	1
B 1		0V	2
A 2	Out	-, TAD0	3
B 2		0V	4
A 3	Out	-, TAD1	5
B 3		0V	6
A4	Out	-, GO (Initiate Com.)	7
B 4		0V	8
A 5	Out	-, REV (Reverse/Forward)	9
B 5		0V	10
A 6	Out	-, WRT (Write/Read)	11
B 6		0V	12
A 7	Out	-, ERASE	13
B 7		0V	14
A 8	Out	-, DEN (Density Sel.)**	15
B 8		0V	16
A 9	Out	-, PAR (Parity Sel.)**	17
B 9		0V	18
A10	Out	-, REV (Rewind Com.)	19
B10		0V	20
A11	Out	-, OFL (Off-Line Com.)	21
B11		0V	22
A12	Out	-, LWD (Last Word)	23
B12		0V	24
A13	Out	-, FEN (Formatter Enable)	25
B13		0V	26
A14	Out	-, W0 (Write Data 0)	51
B14		0V	50
A15	Out	-, W1 (Write Data 1)	49
B15		0V	48
A16	Out	-, W2 (Write Data 2)	47
B16		0V	46
A17	Out	-, W3 (Write Data 3)	45
B17		0V	44
A18	Out	-, W4 (Write Data 4)	43
B18		0V	42
A19	Out	-, W5 (Write Data 5)	41
B19		0V	40
A20	Out	-, W6 (Write Data 6)	39
B20		0V	38
A21	Out	-, W7 (Write Data 7)	37
B21		0V	36
A22	In	-, FBY (Formatter Busy)	35
B22		0V	34
A23	In	-, DBY (Data Busy)	33
B23		0V	32
A24	In	-, CCG (Check Char.)	31
B24		0V	30
A25	In	-, HER (Hard Error)	29
B25		0V	28

\*Gen.addr. Out = Output from Controller to Formatter  
 In = Input from Formatter to Controller

\*\*Only for 7 track transport

Fig. 9 Signal List.

Connector 1002	Gen. addr.	Signal Name	Connector MTC311-J1
A26	In	-, CER (Corrected Error)	27
B26		0V	52
A27	In	-, FMK (File Mark)	53
B27		0V	54
A28	In	-, RDY (Ready)	55
B28		0V	56
A29	In	-, ONL (ON Line)	57
B29		0V	58
A30	In	-, RWD (Rewinding)	59
B30		0V	60
A31	In	-, FPT (File Protect)	61
B31		0V	62
A32	In	-, LDP (Load Point)	63
B32		0V	64
A33	In	-, EOT (End of Tape)	65
B33		0V	66
A34	In	-, NRZI (NRZI Status)	67
B34		0V	68
A35	In	-, 7-track	69
B35		0V	70
A36	In	-, WS (Write Strobe)	71
B36		0V	72
A37	In	-, RS (Read Strobe)	73
B37		0V	74
A38	In	-, RP (Read Data P)	75
B38		0V	100
A39	In	-, R0 (Read Data 0)	99
B39		0V	98
A40	In	-, R1 (Read Data 1)	97
B40		0V	96
A41	In	-, R2 (Read Data 2)	95
B41		0V	94
A42	In	-, R3 (Read Data 3)	93
B42		0V	92
A43	In	-, R4 (Read Data 4)	91
B43		0V	90
A44	In	-, R5 (Read Data 5)	89
B44		0V	88
A45	In	-, R6 (Read Data 6)	87
B45		0V	86
A46	In	-, R7 (Read Data 7)	85
B46		0V	84
A47			83
B47			82
A48			81
B48			80
A49			79
B49			78
		Chassis	77
		Chassis	76

\* Gen.addr. Out = Output from Controller  
to formatter  
In = Input from Formatter  
to Controller

Fig. 10 Signal List

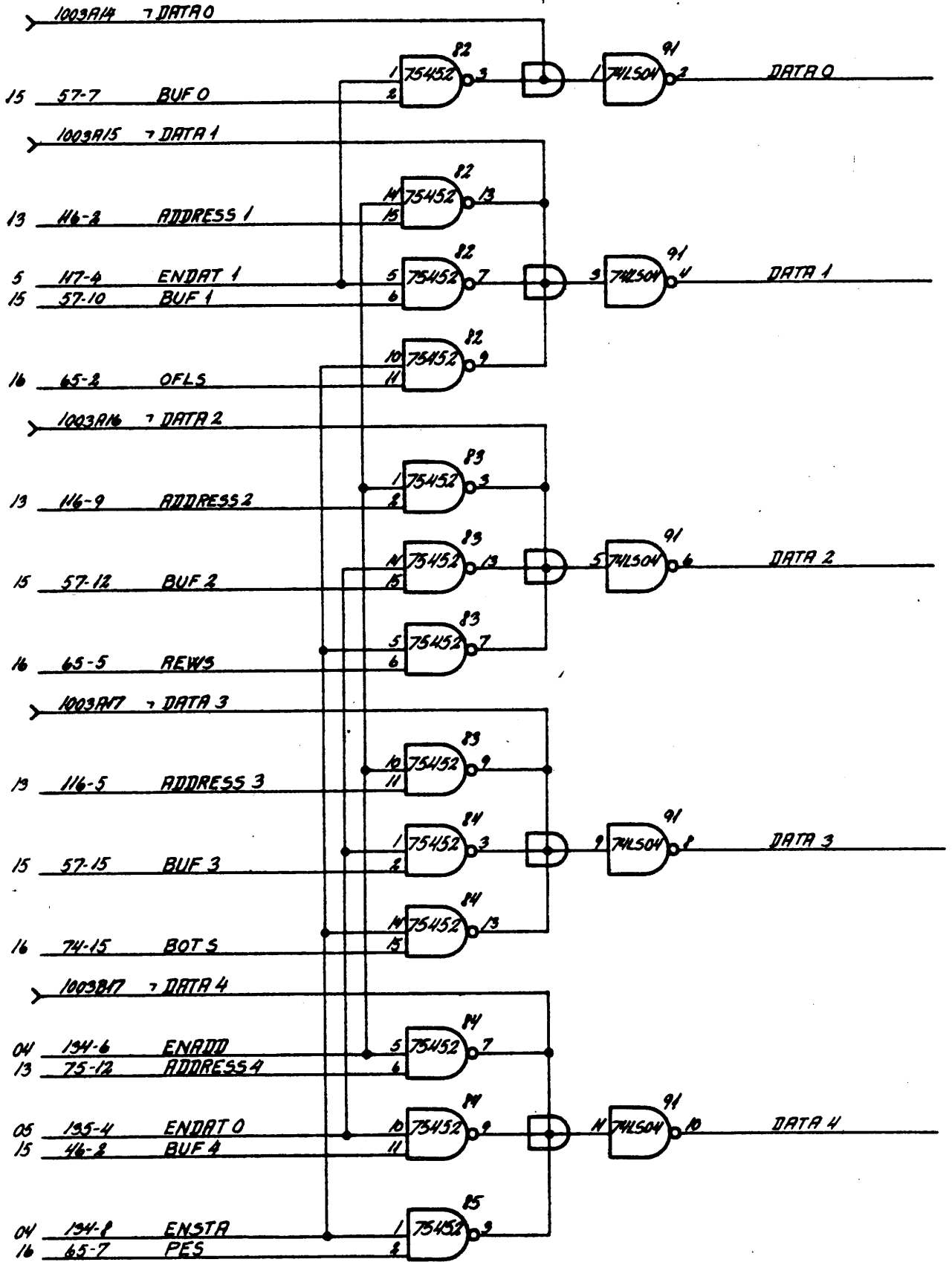

760903 MVP 760903 ROB

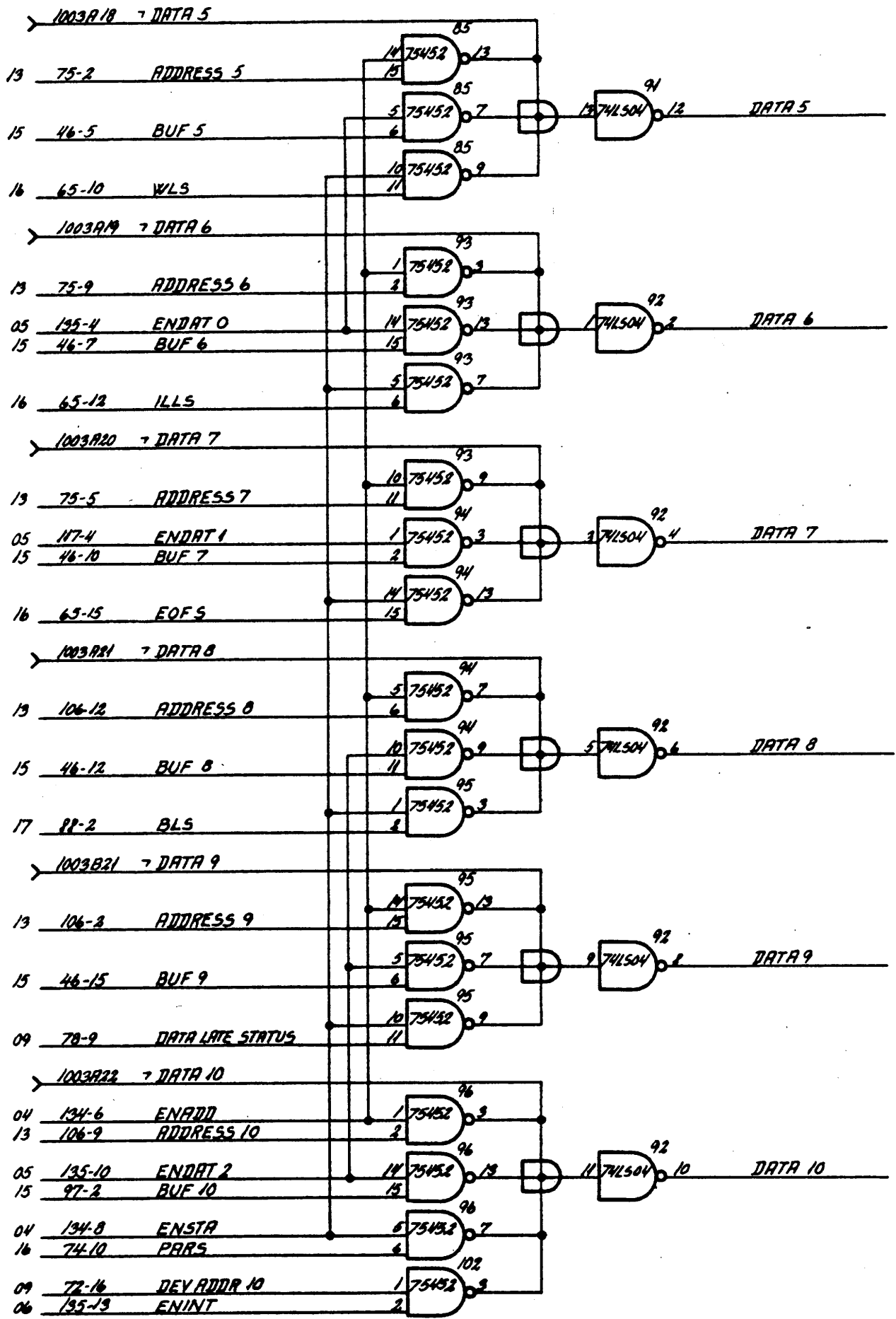

760903 MIP 760903 008

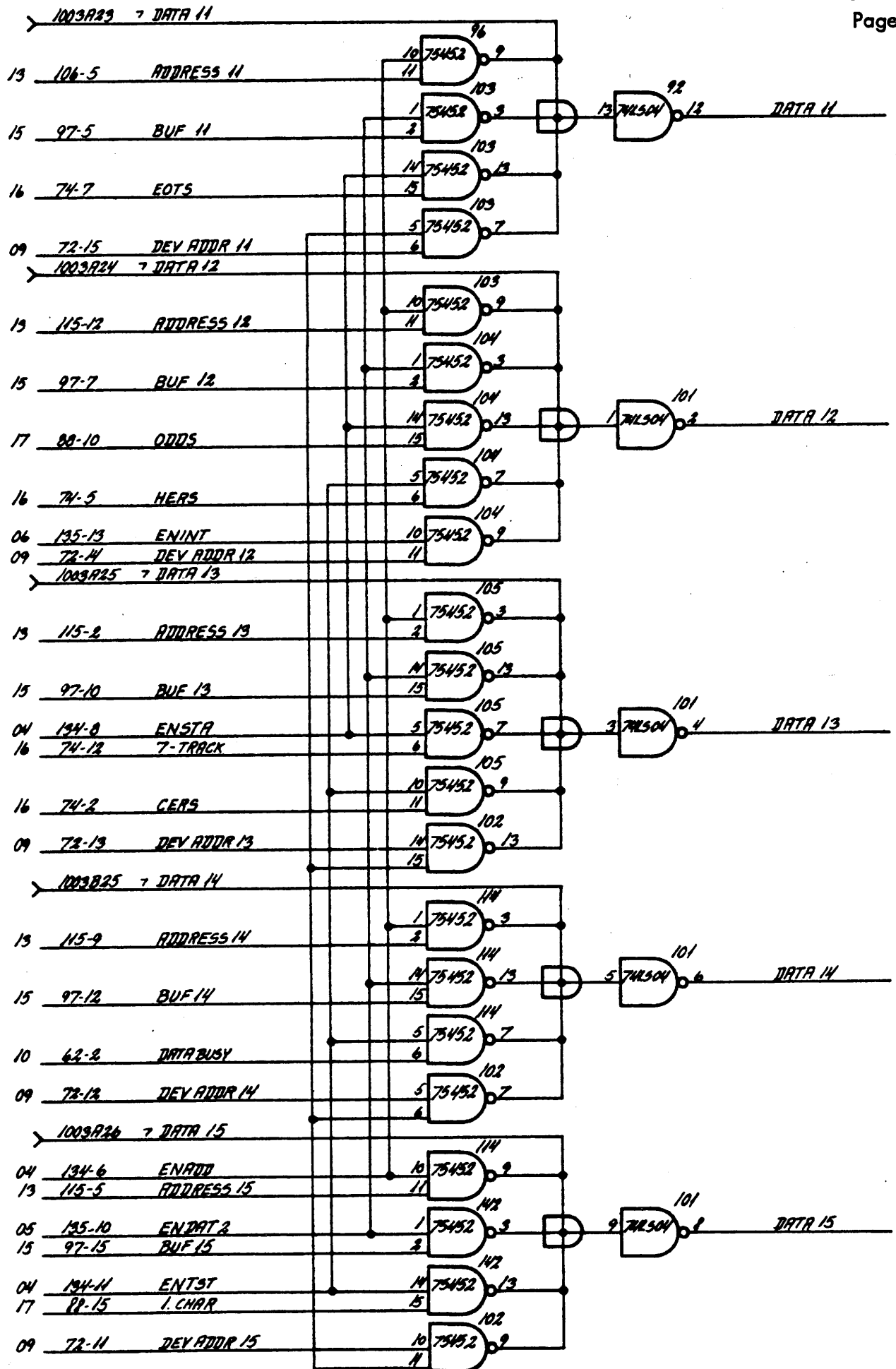

76003 MIP 76003 ROB



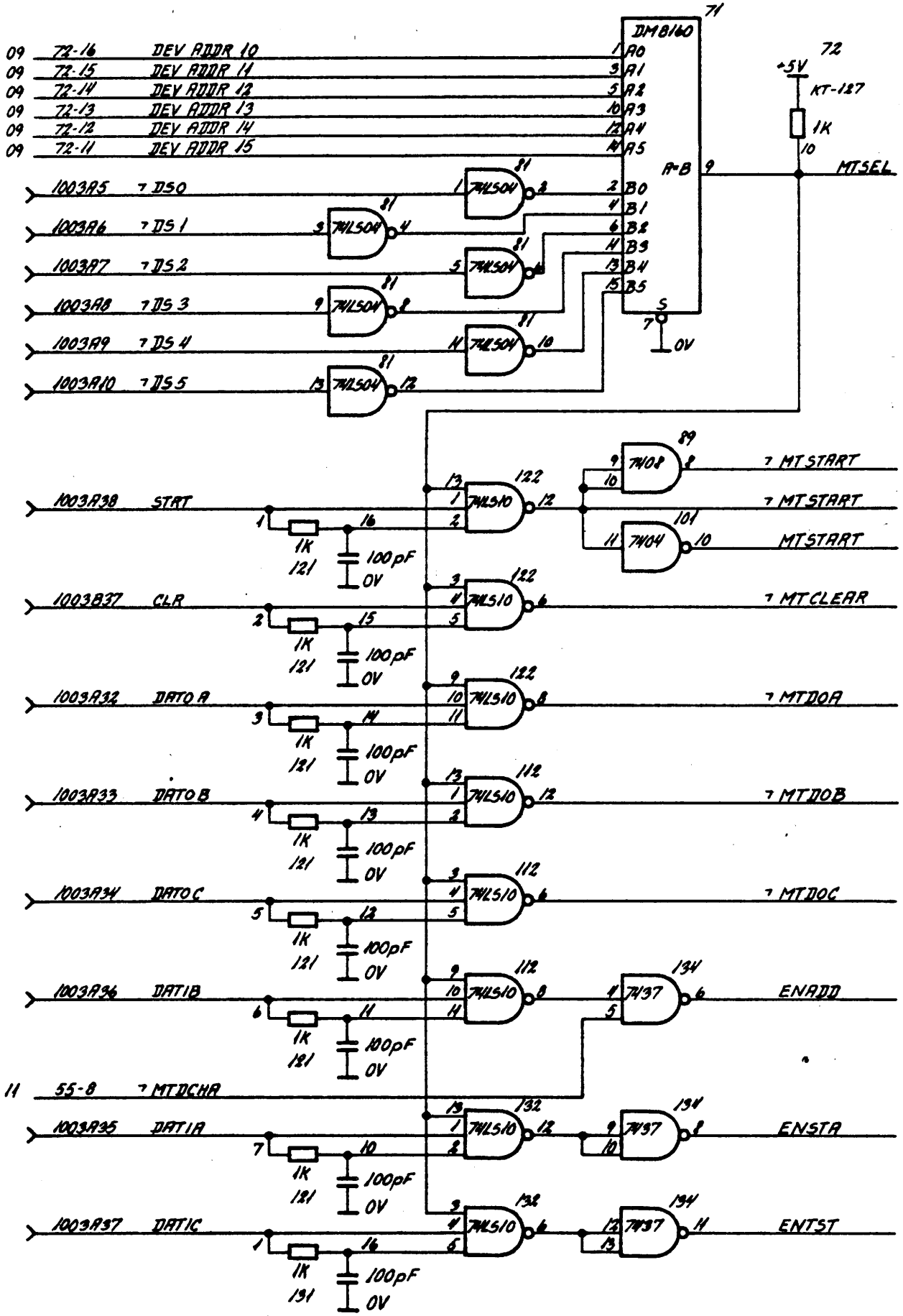

760903 MIP 760903 ROB

MTC 34  
R11633

DEVICE SELECTION

MTC  
04

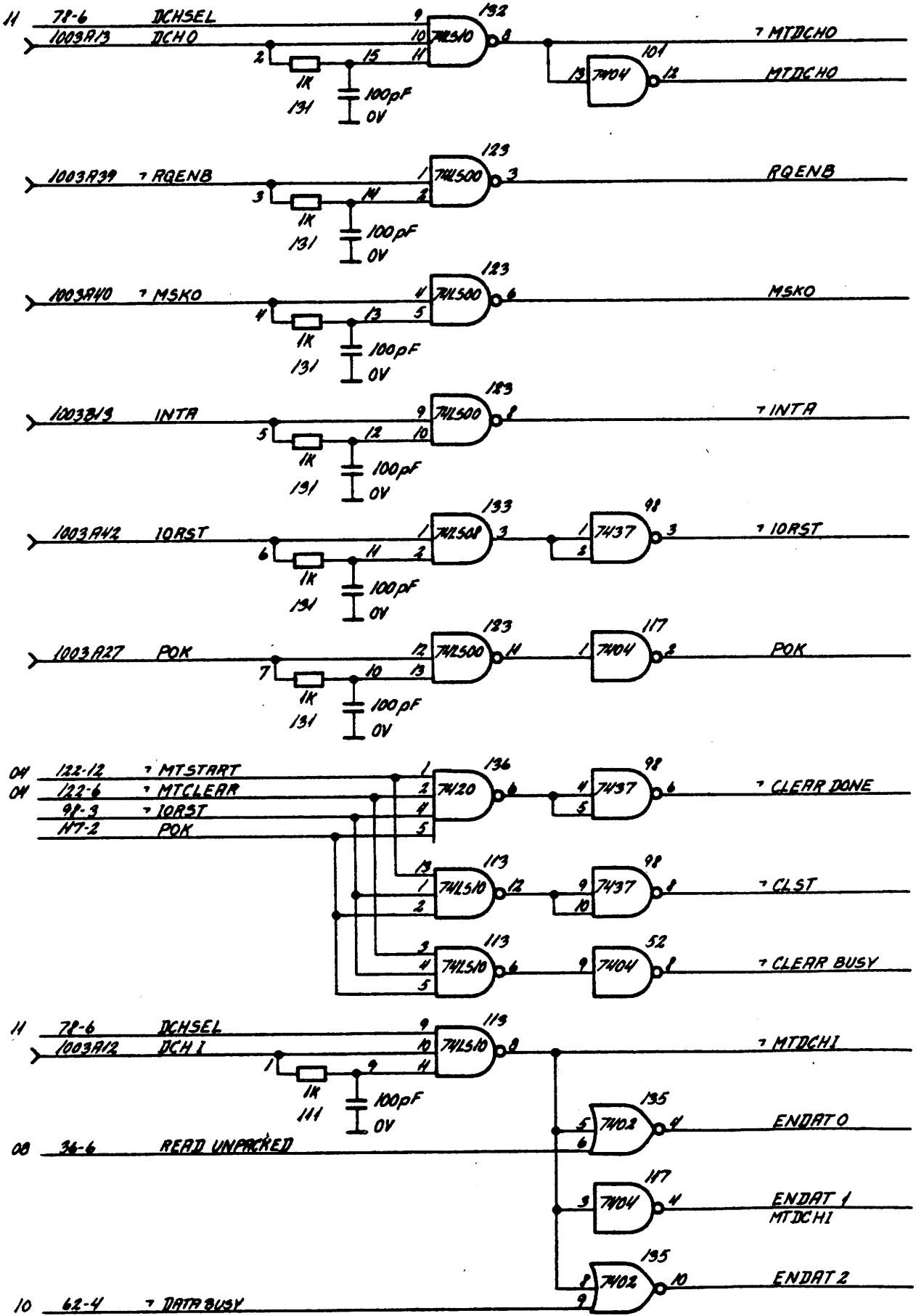

808 60902 760903 808

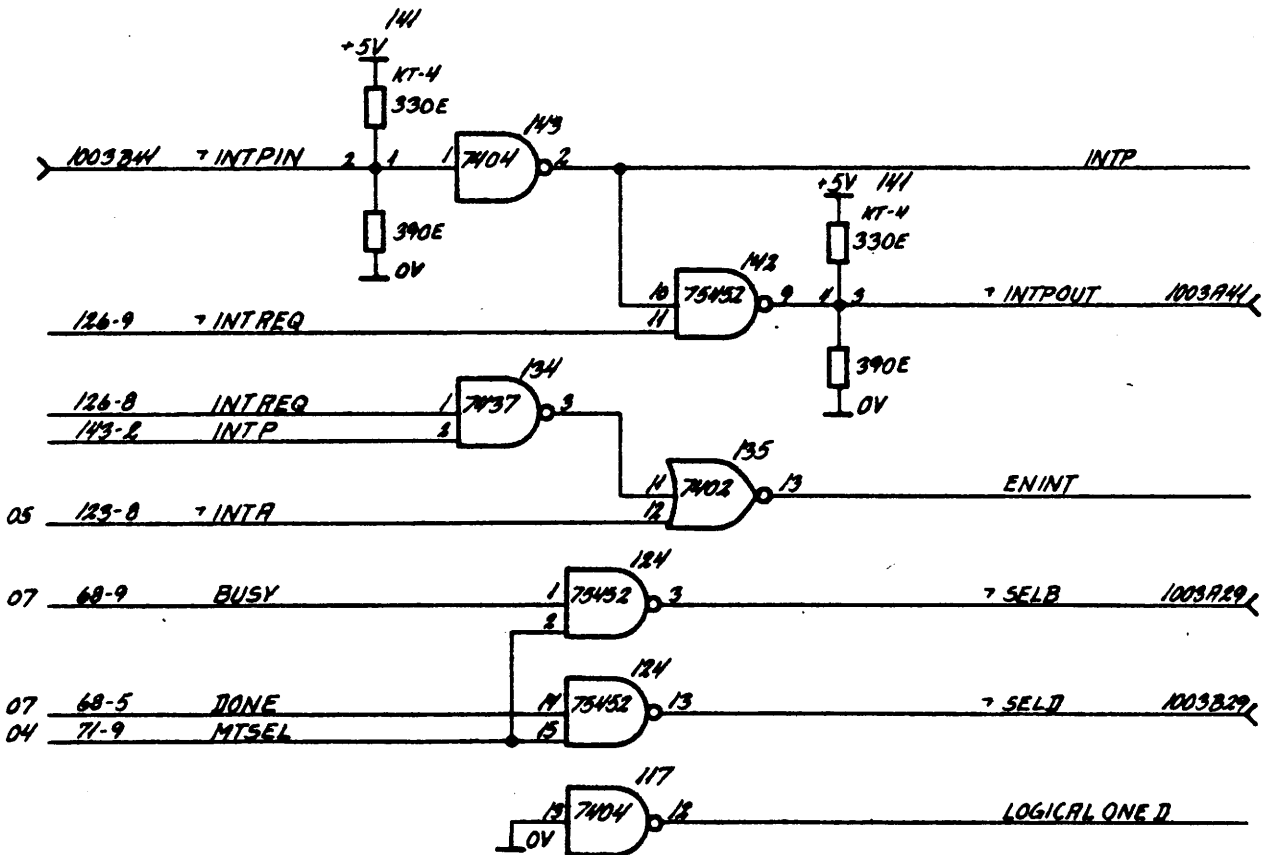
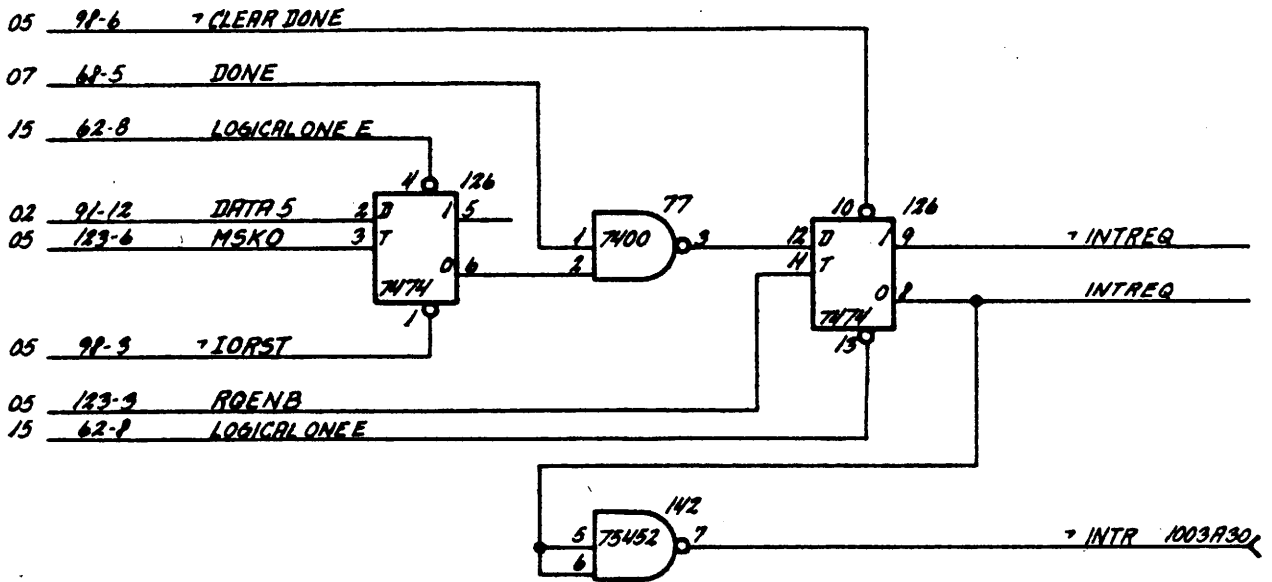

760903 MIP 760903 A03

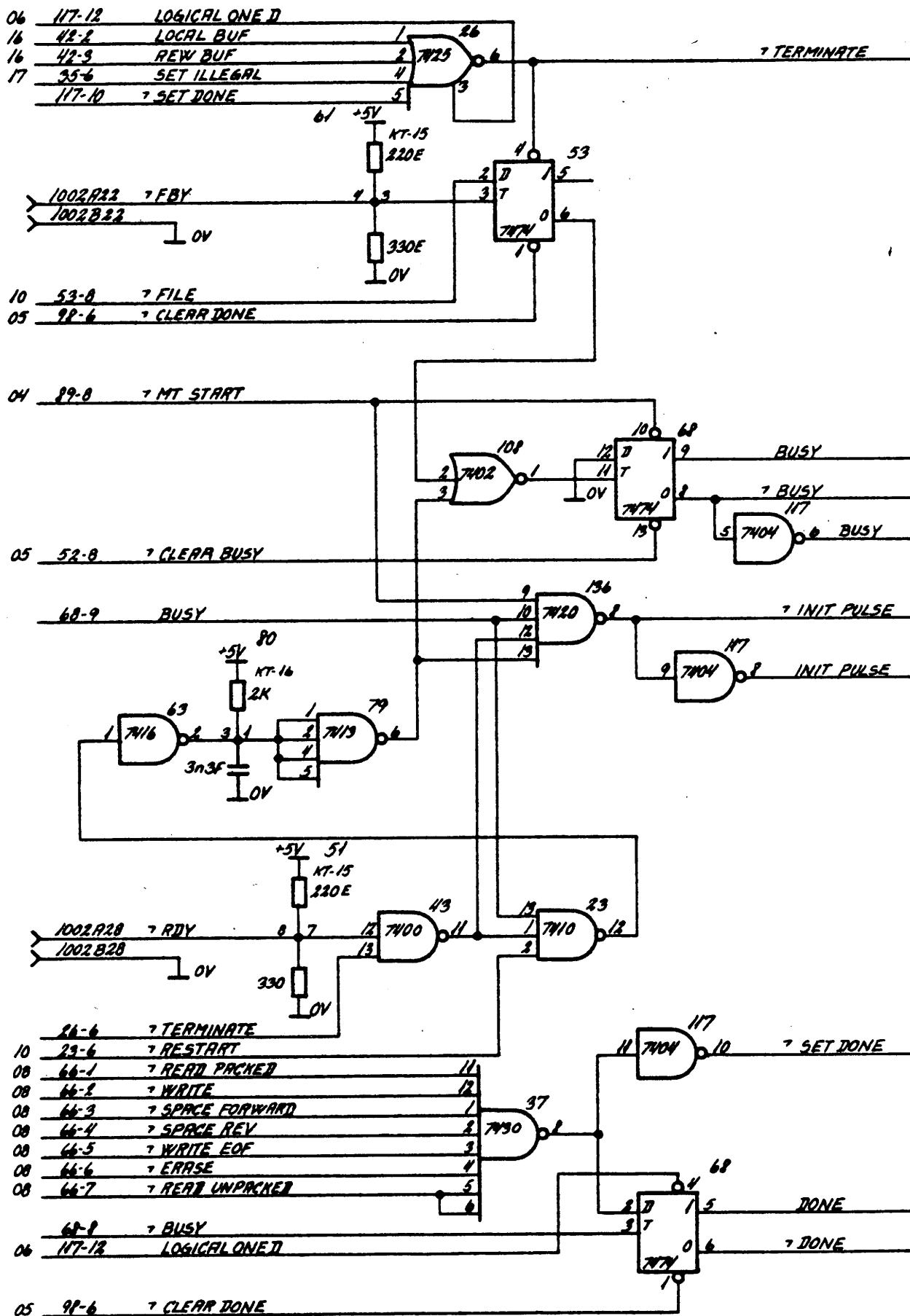

76093 MYP 76093 ROB

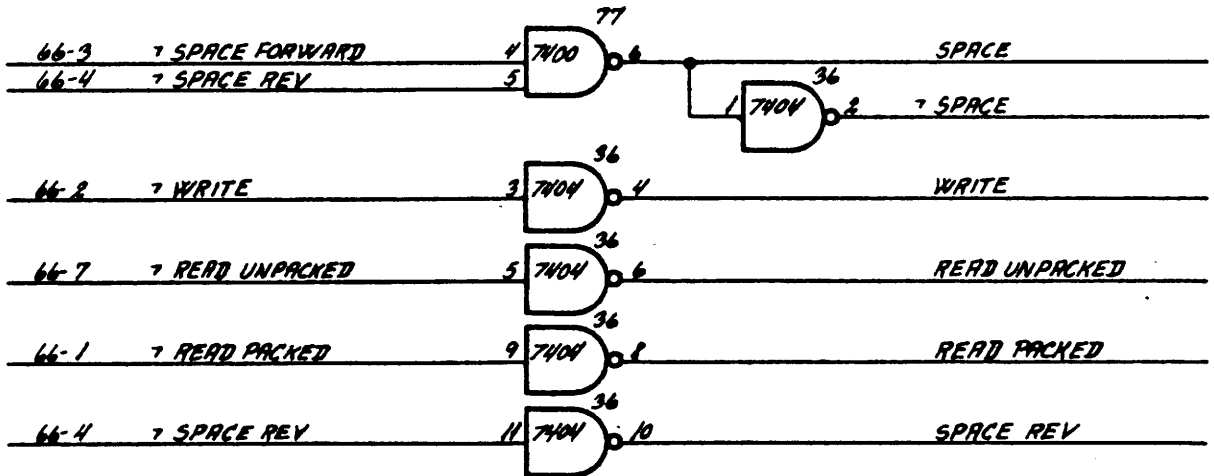
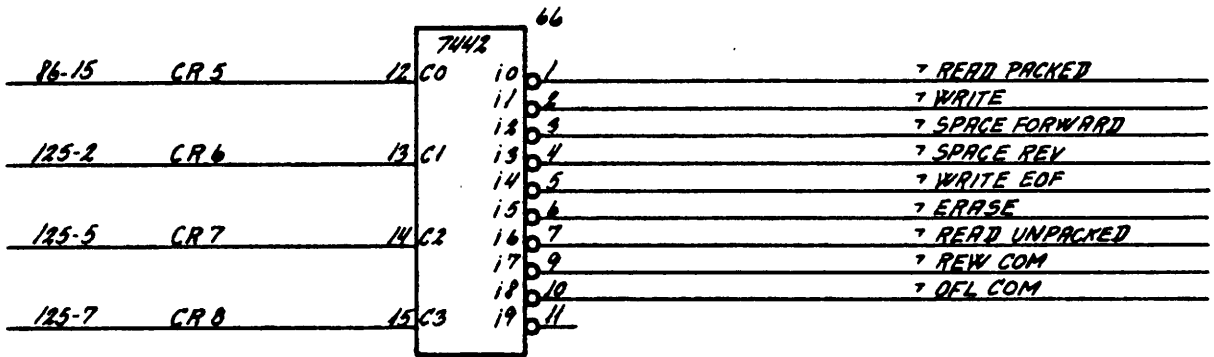
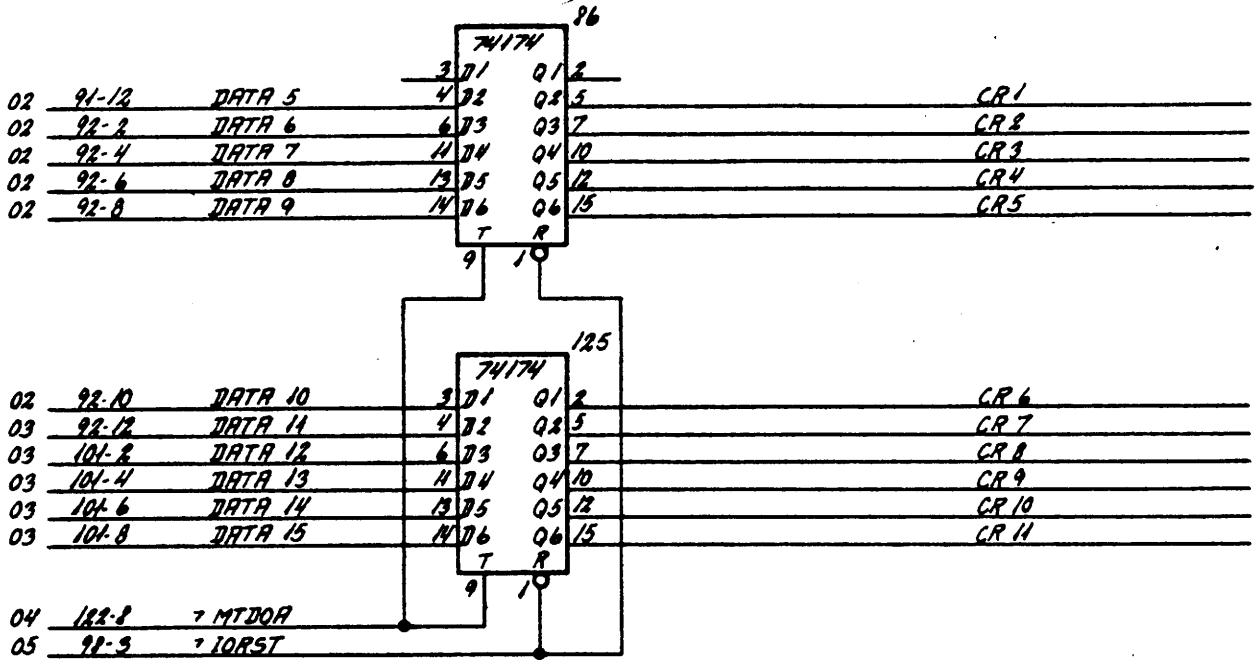

780903 MYP 780903 ROB

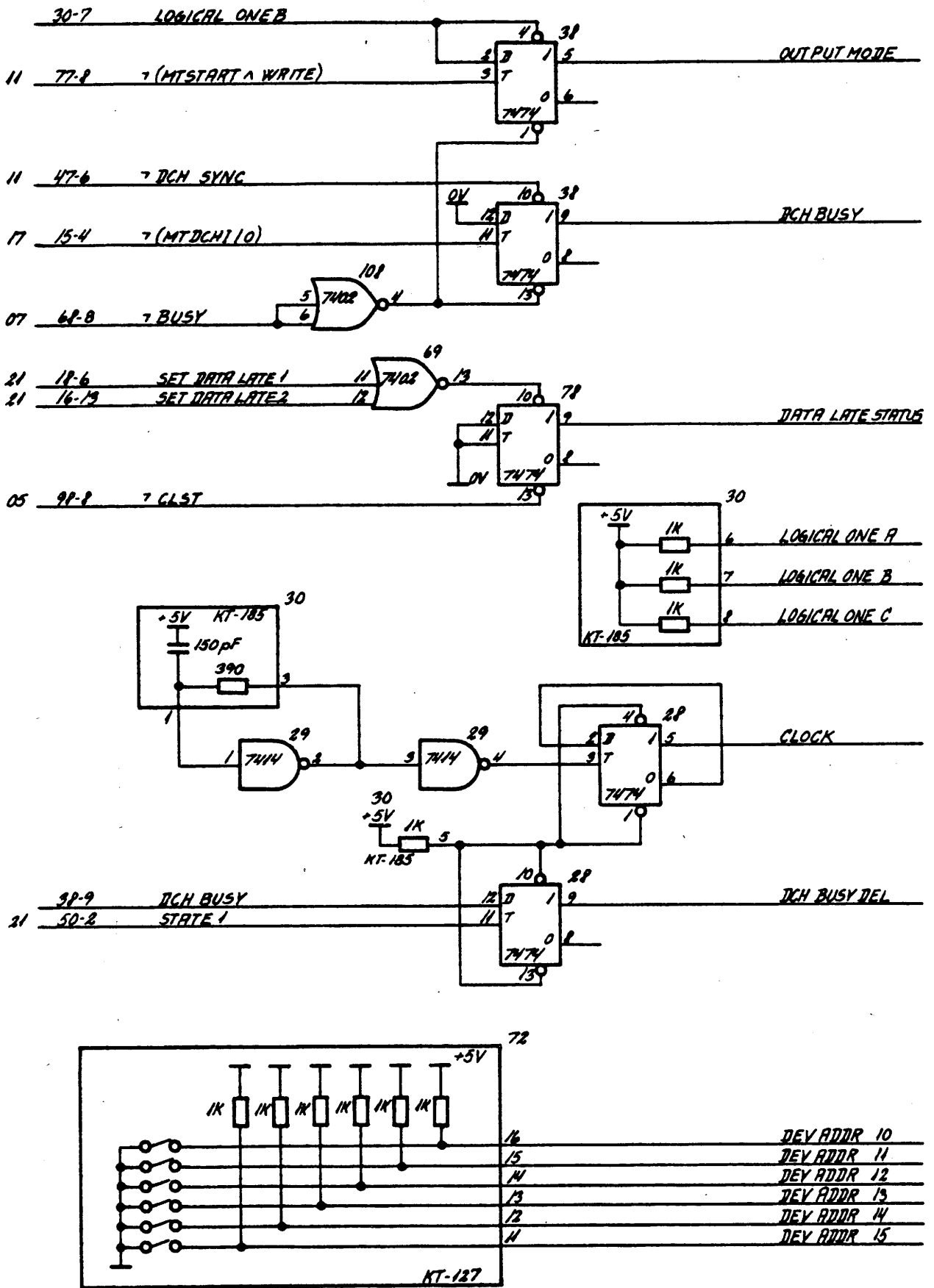

760903 MIP 760903 A08

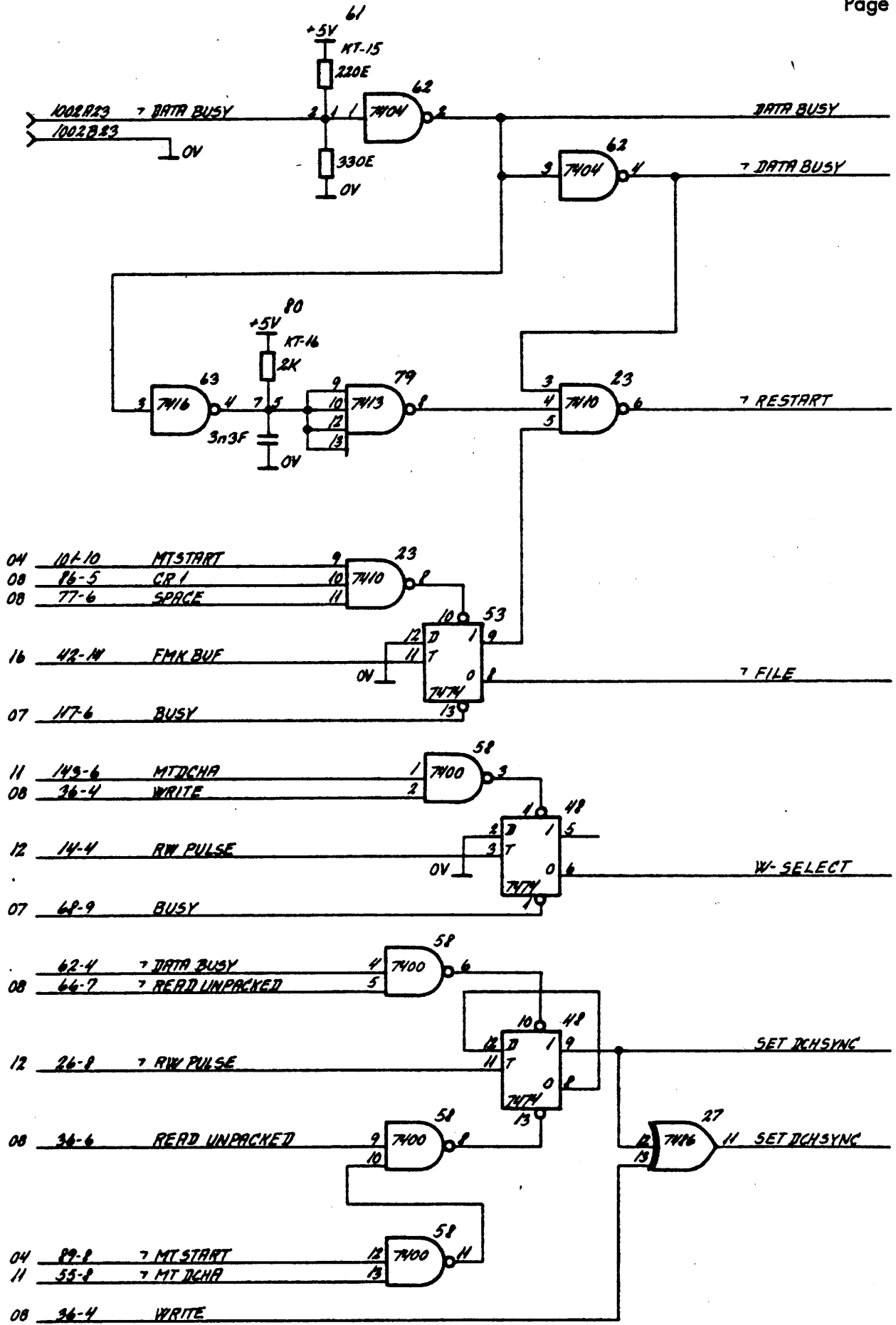

760903 MIP 760903 ADB

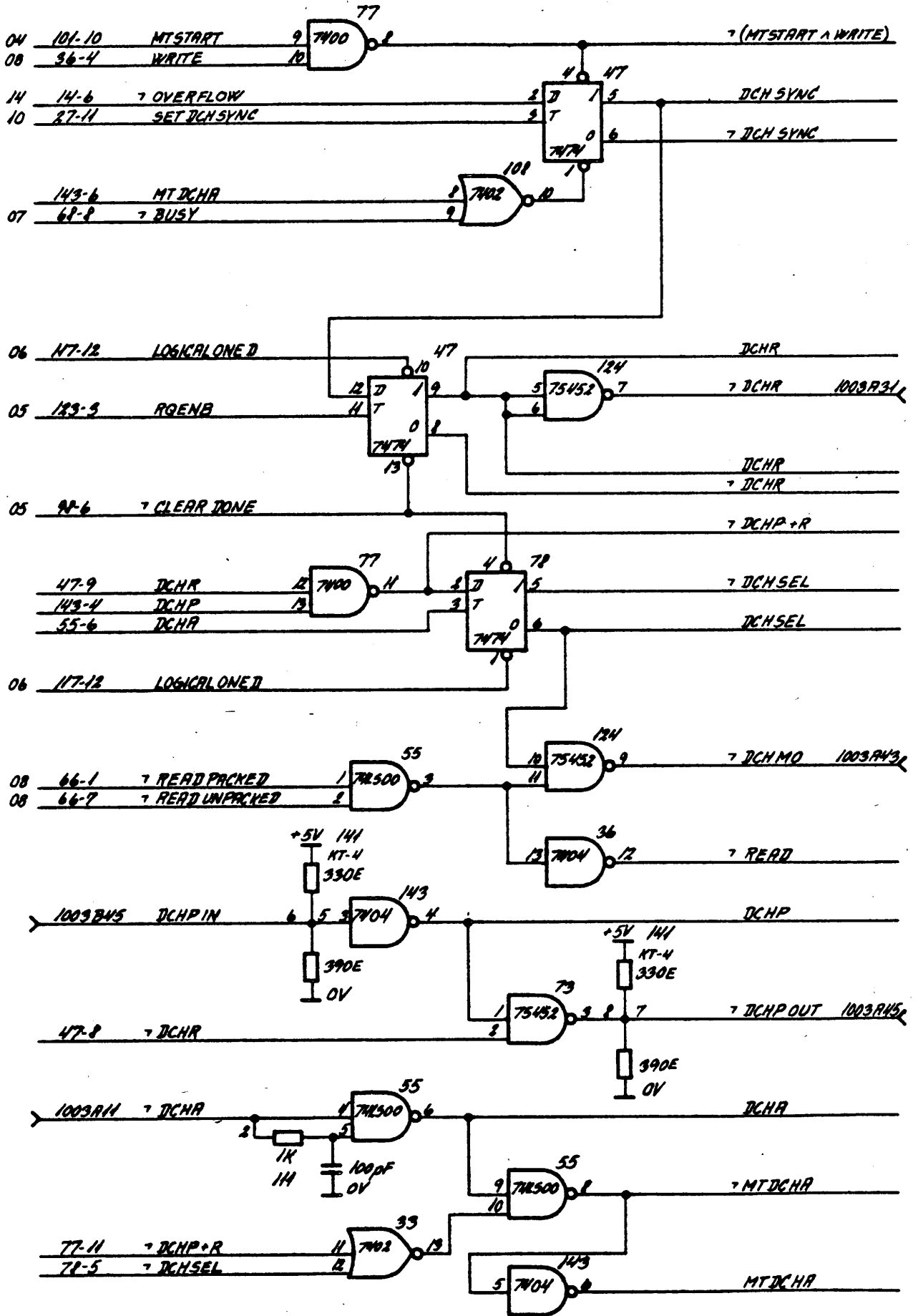

760903 MIP 760903 A03



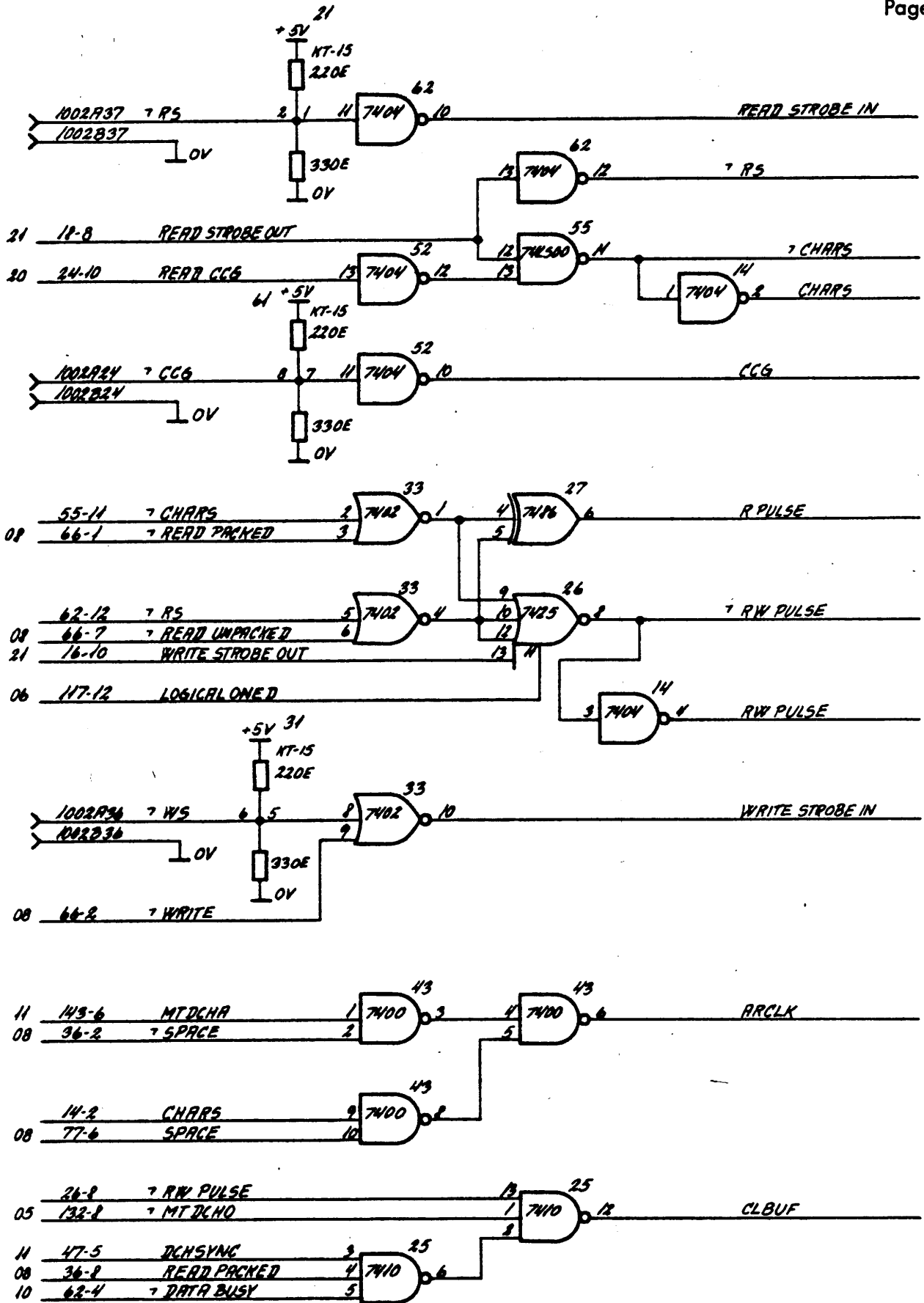

760903 MYP 760903 ROB

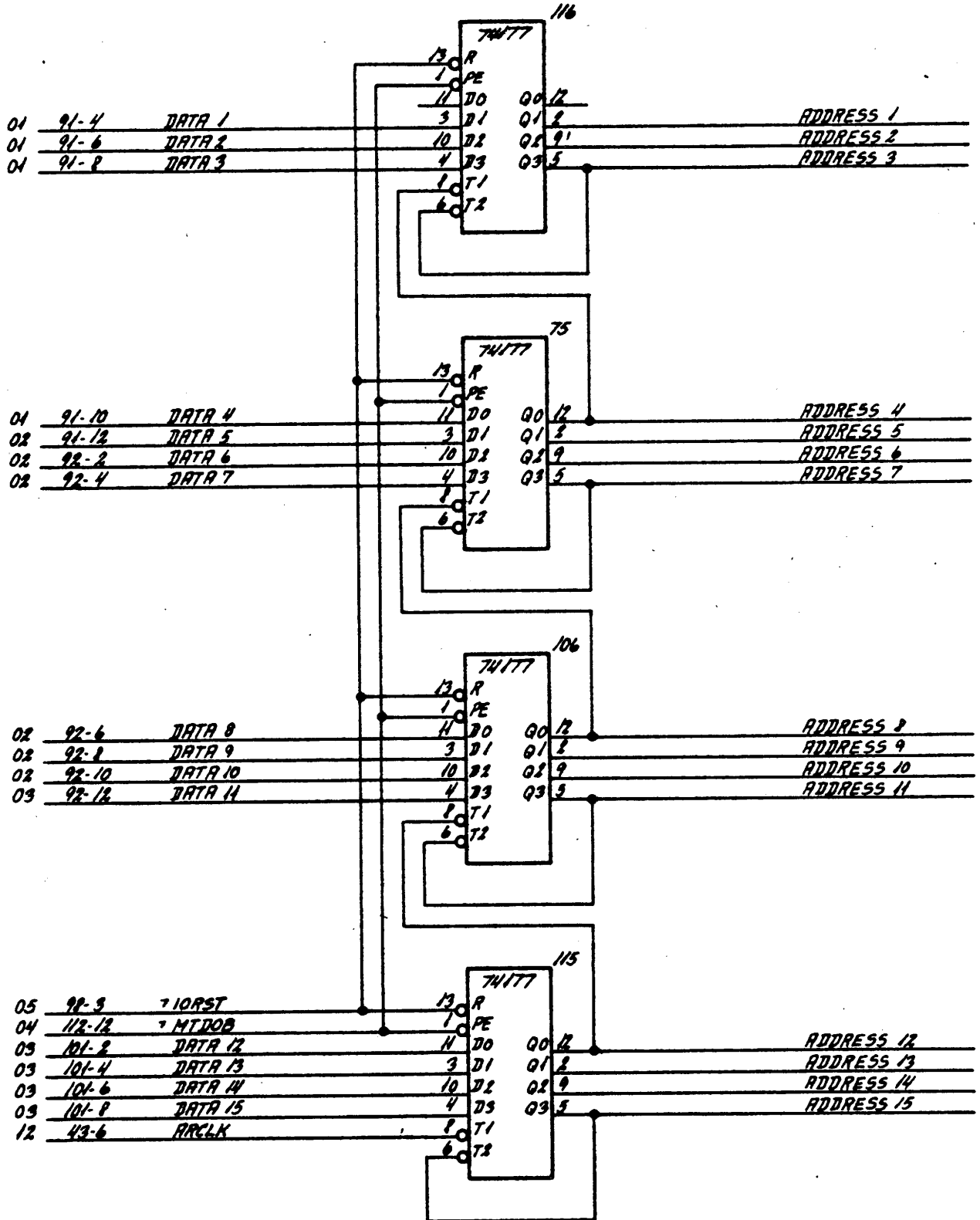

760903 MYP 760903 A05

MTC34

ADDRESS REGISTER

MTC  
13

R11642

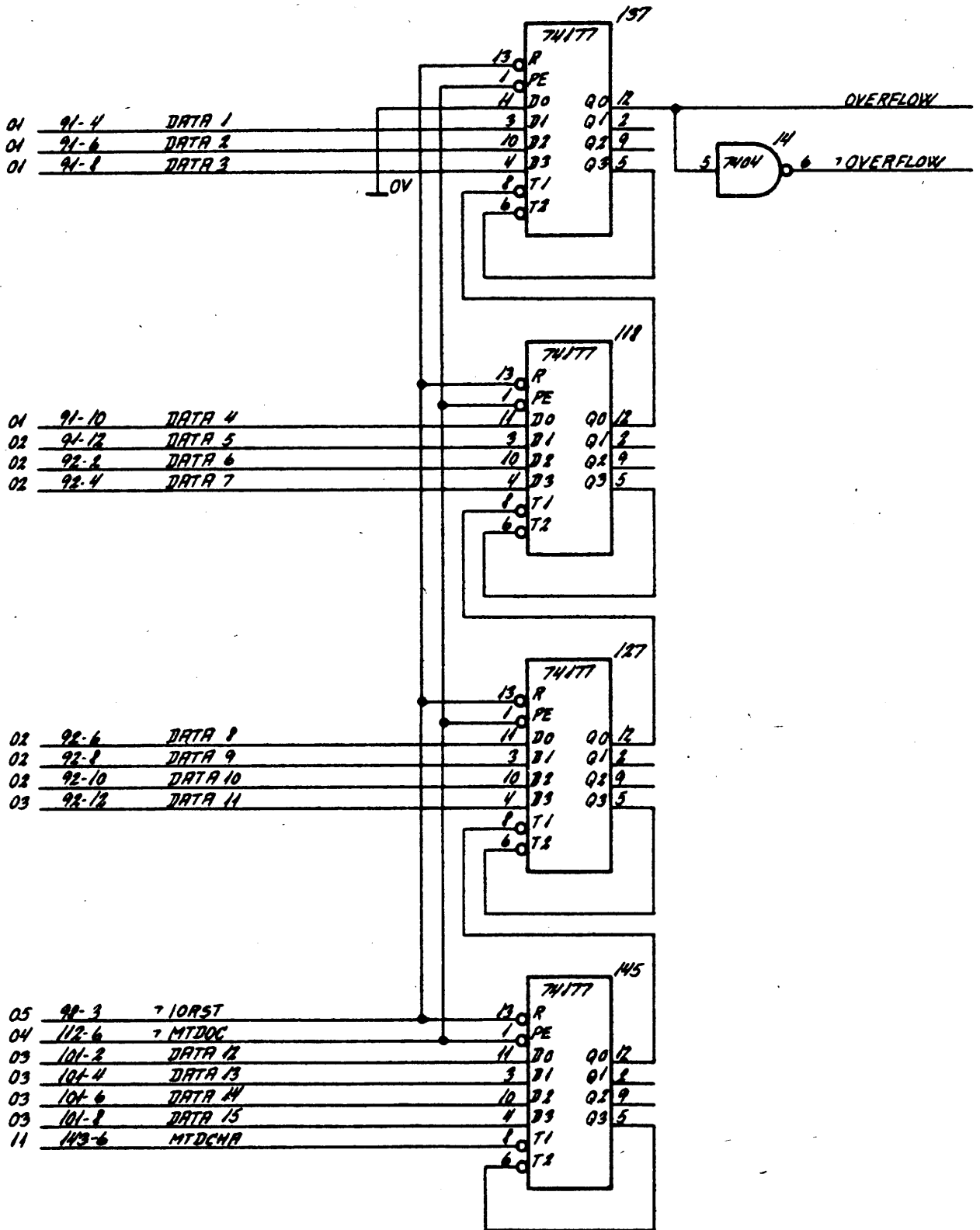

760903 MVP 760903 ASD

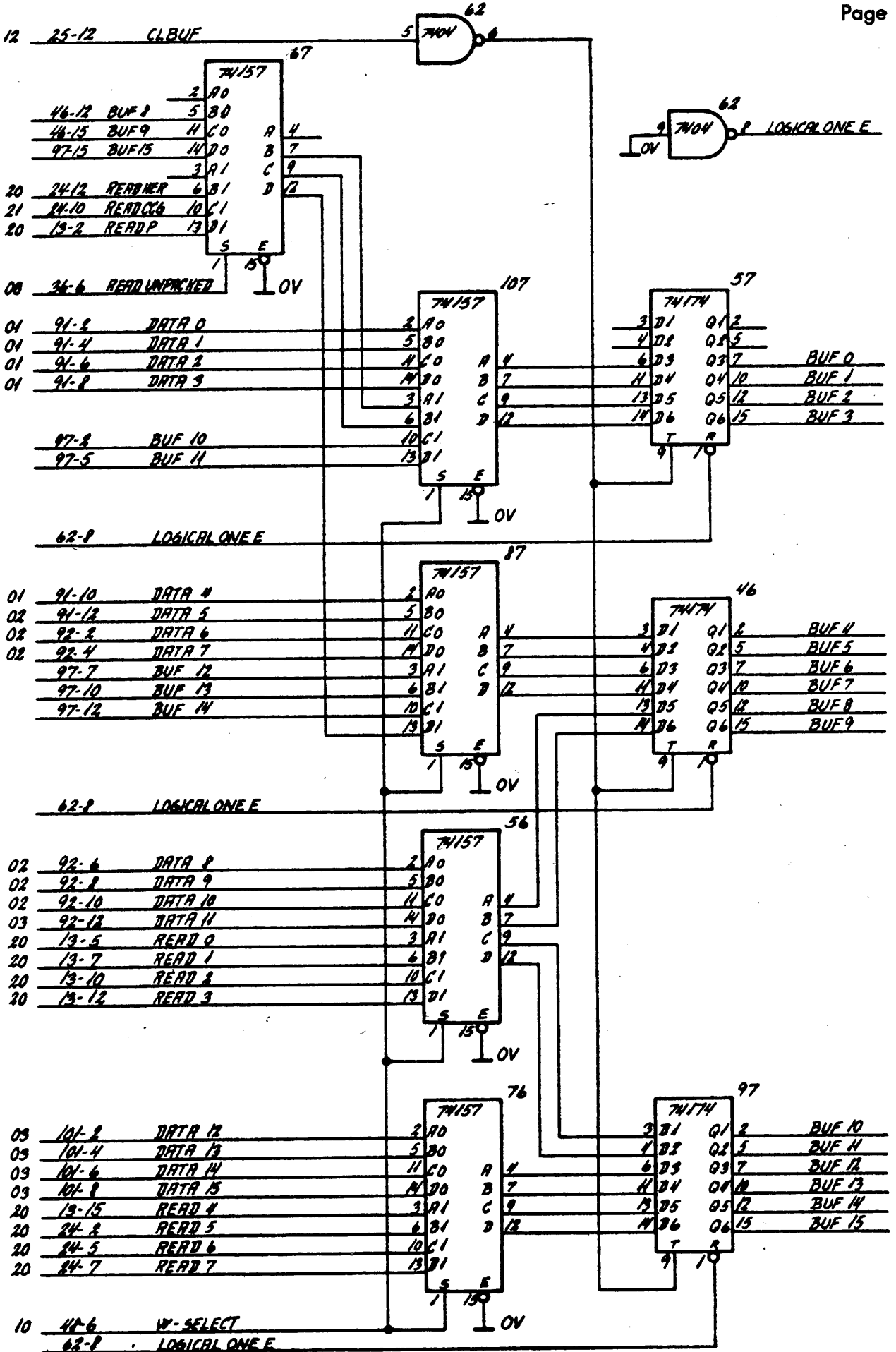

760903 MIP 760903 A08

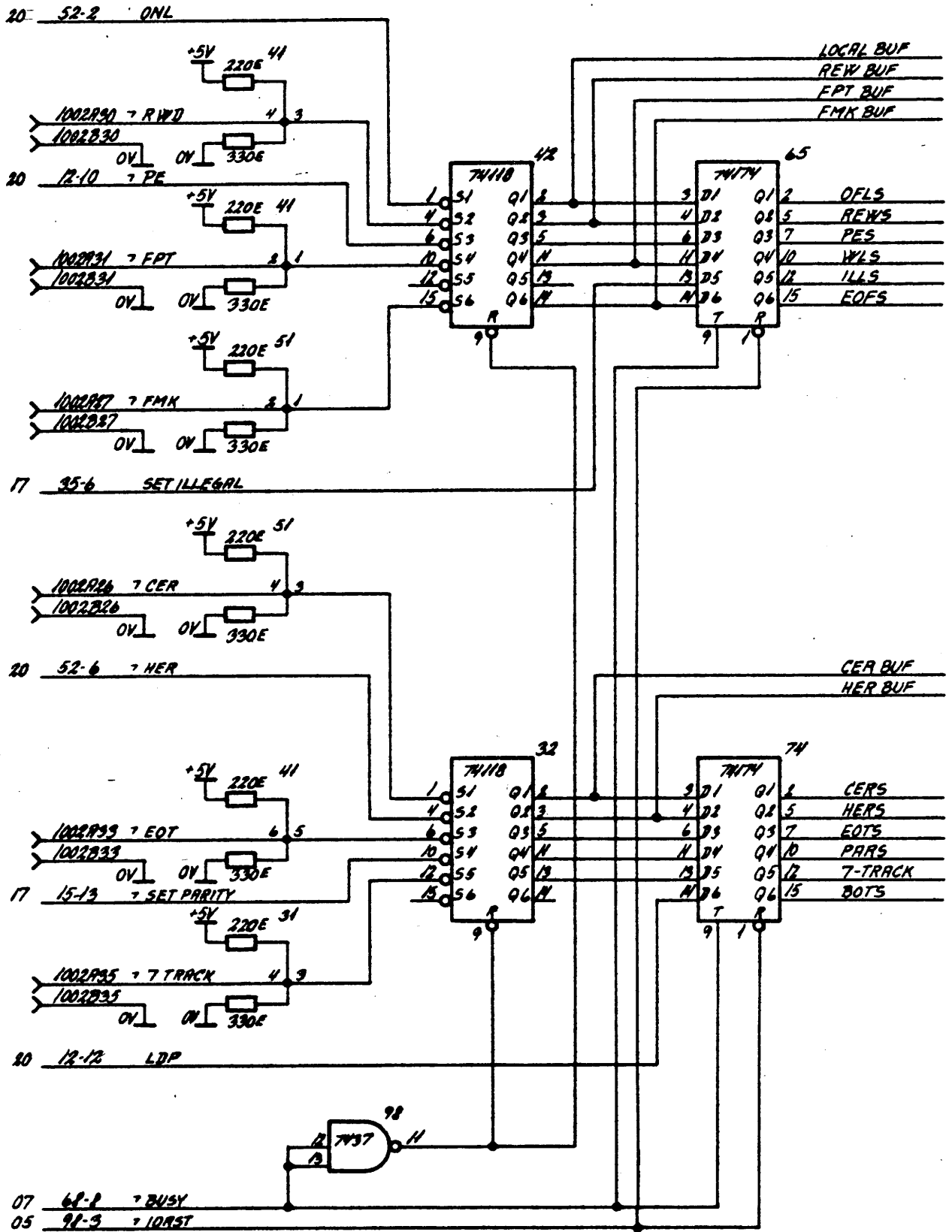

760903 MYP 760903 ROB

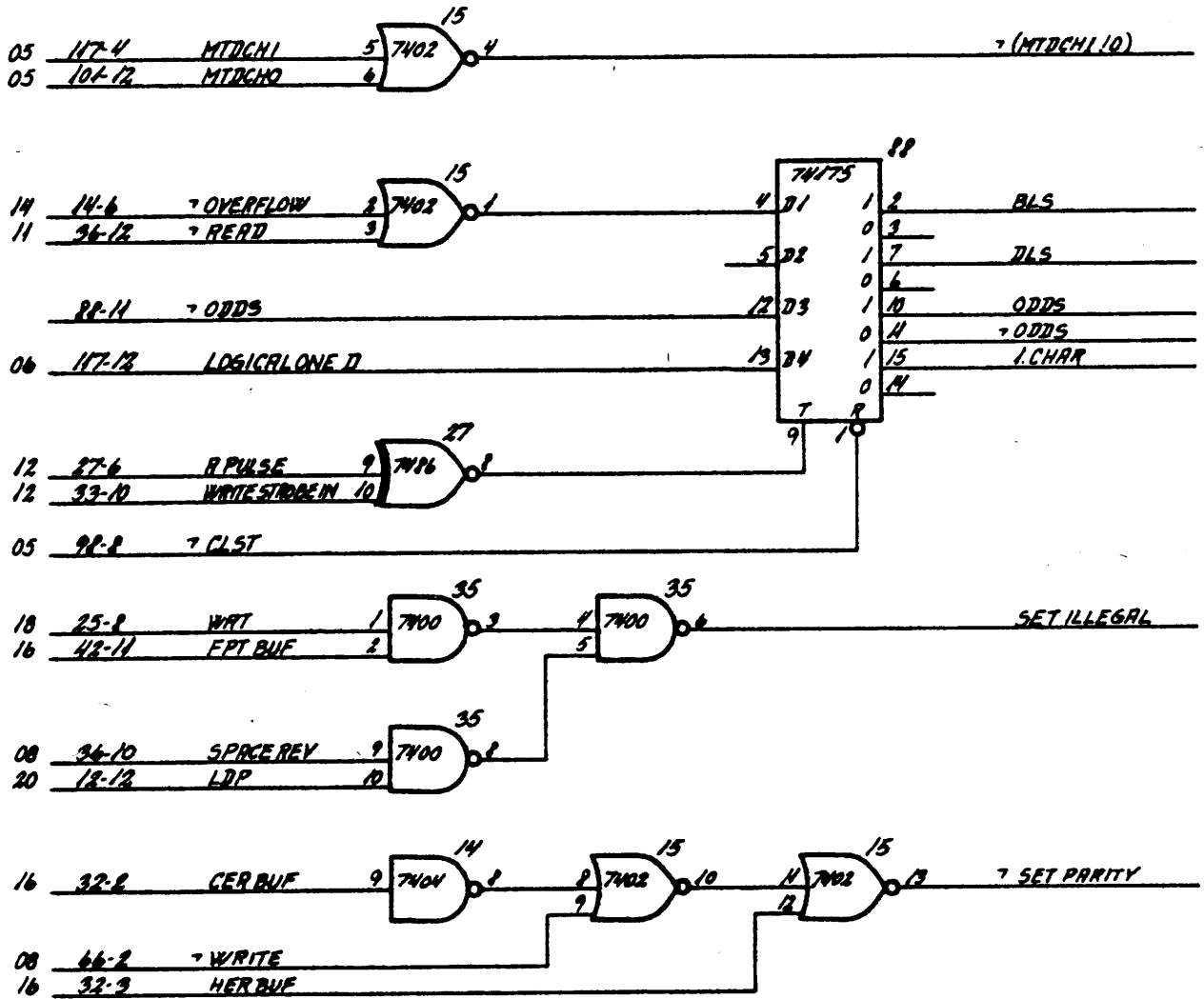

760903 MIP 760903 AOB

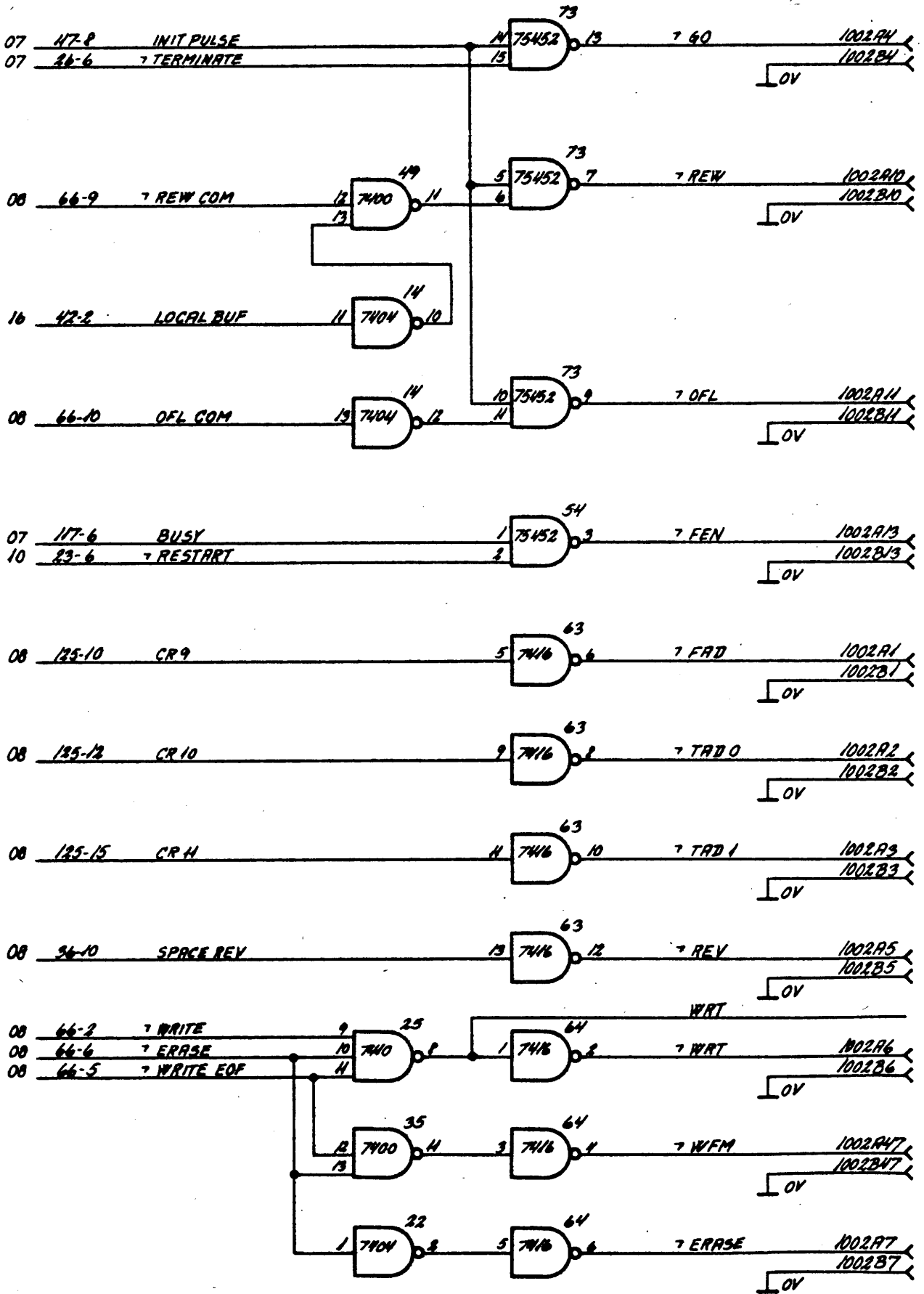

760903 MIP 760903 A08

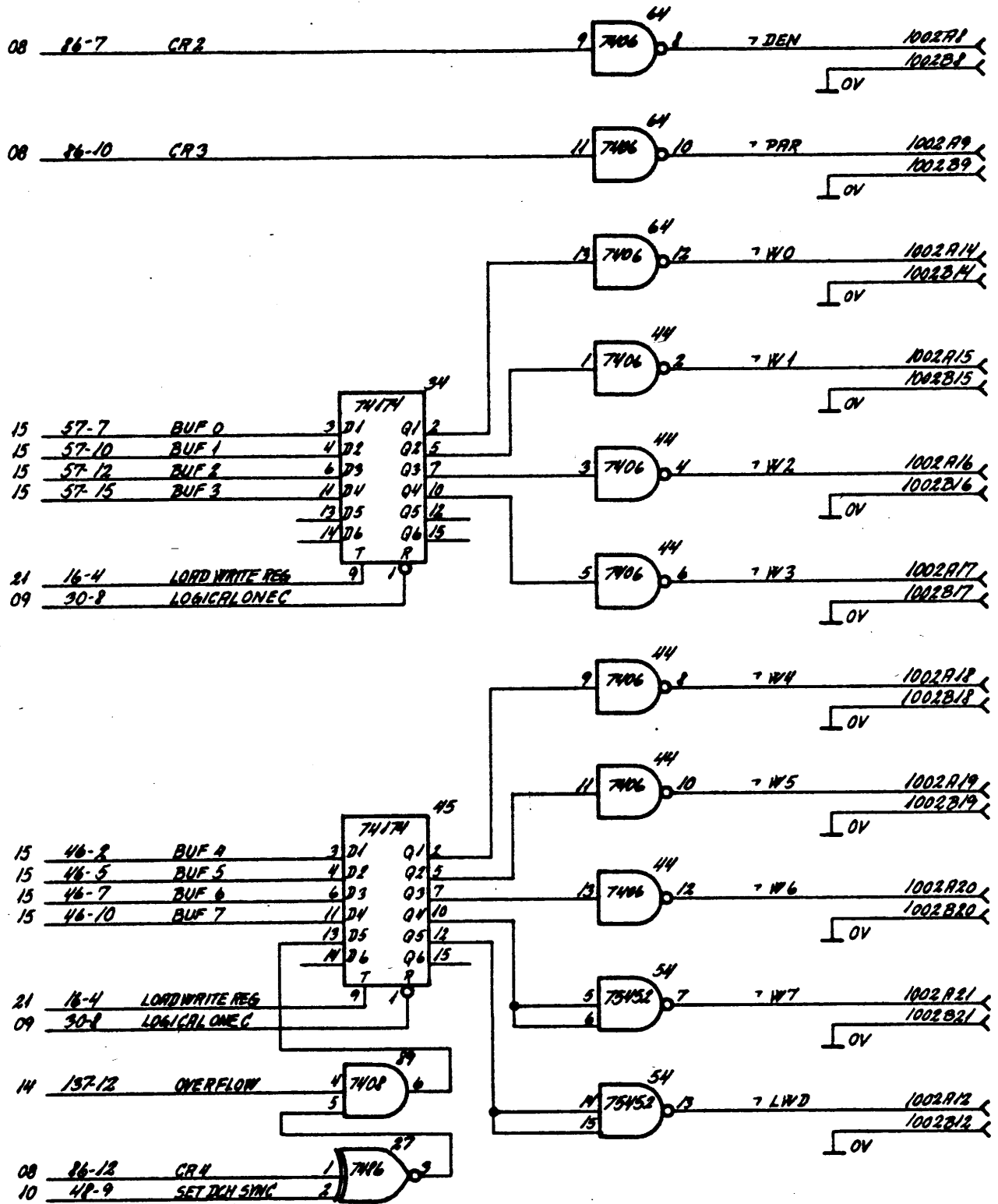

760903 MYP 760903 A03



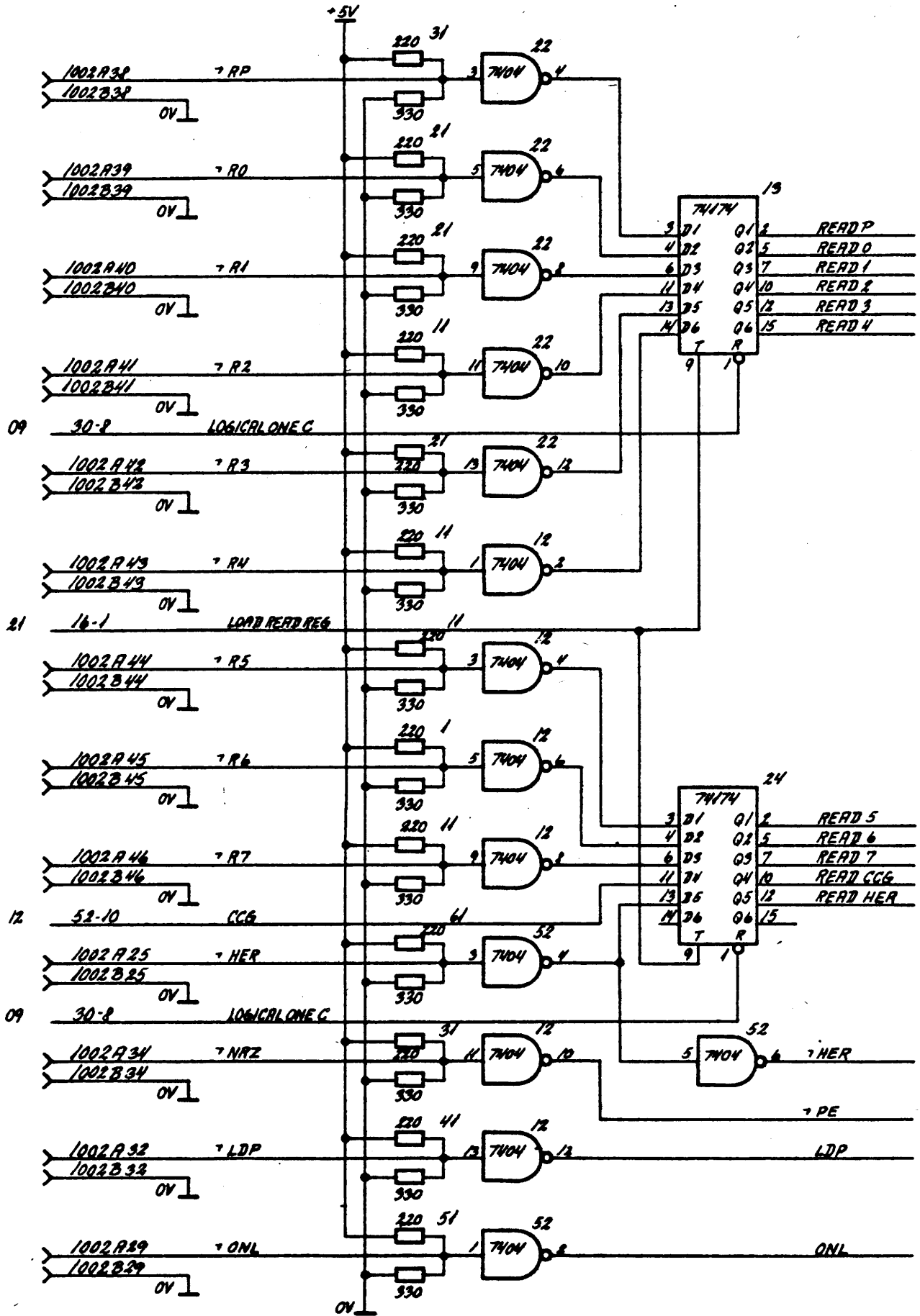

760903 MYP 760903 ROB

MTC34  
R11649

DATA AND CONTROL SIGNALS FROM  
FORMATTER AND READ REG

MTC  
20

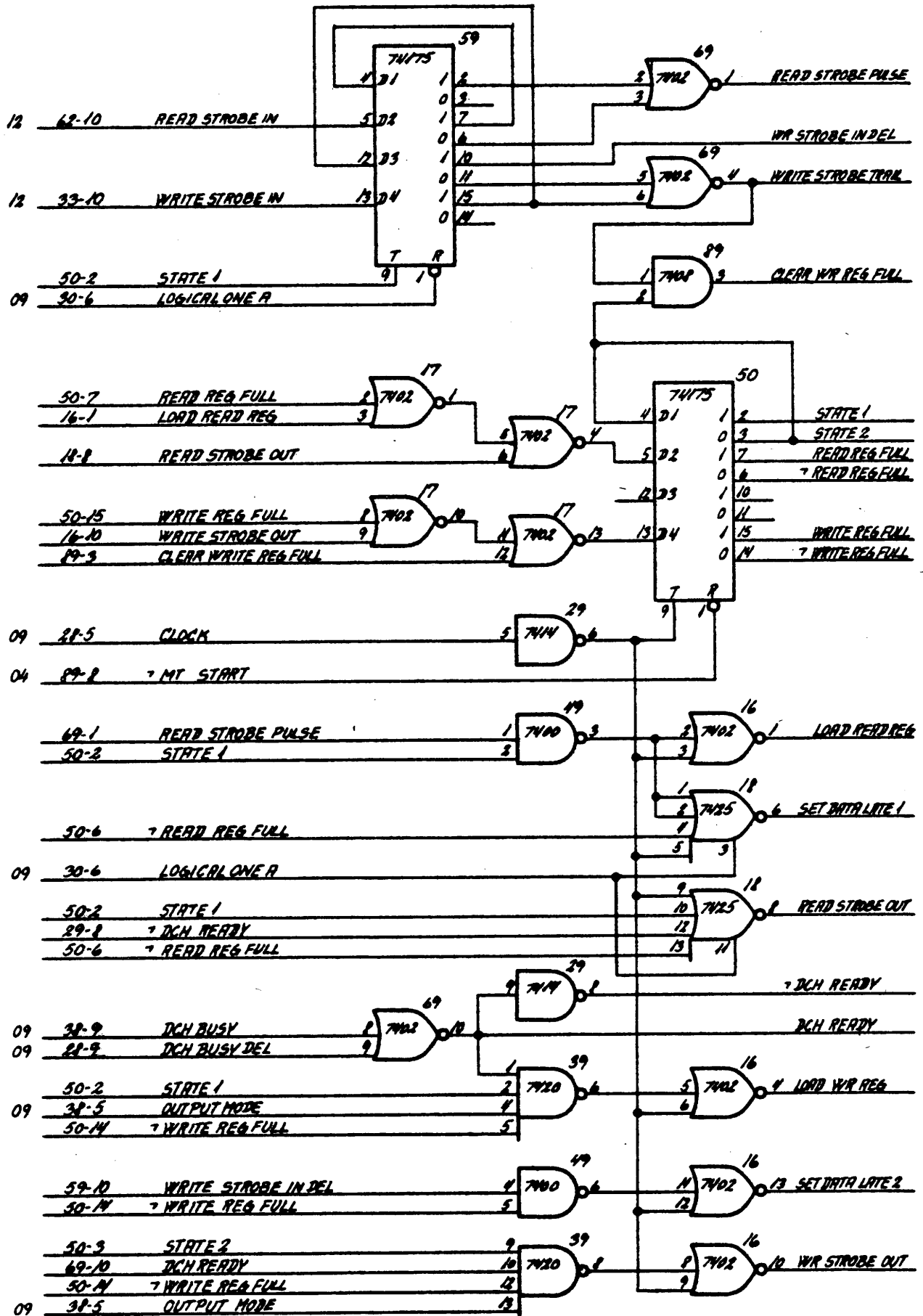

760903 MIP 760903 A03

**RETURN LETTER**

Title: \_\_\_\_\_

RCSL No.: \_\_\_\_\_

A/S Regnecentralen af 1979/RC Computer A/S maintains a continual effort to improve the quality and usefulness of its publications. To do this effectively we need user feedback, your critical evaluation of this manual.

Please comment on this manual's completeness, accuracy, organization, usability, and readability:

---

---

---

---

Do you find errors in this manual? If so, specify by page.

---

---

---

---

How can this manual be improved?

---

---

---

---

Other comments?

---

---

---

---

---

Name: \_\_\_\_\_ Title: \_\_\_\_\_

Company: \_\_\_\_\_

Address: \_\_\_\_\_

Date: \_\_\_\_\_

Thank you

..... **Fold here** .....

..... **Do not tear - Fold here and staple** .....

Affix  
postage  
here

**E** **REGNECENTRALEN**  
af 1979

Information Department  
Lautrupbjerg 1  
DK-2750 Ballerup  
Denmark